

BVT4500H / BVT5500H

ULTRABASS

User Manual

en

A50-52113-00003



www.behringer.com



ULTRABASS BVT4500H/BVT5500H

Important Safety Instructions



This symbol, wherever it appears, alerts you to the presence of uninsulated dangerous voltage inside the enclosure - voltage that may be sufficient to constitute a risk of shock.



This symbol, wherever it appears, alerts you to important operating and maintenance instructions in the accompanying literature. Please read the manual.

Caution

- To reduce the risk of electric shock, do not remove the top cover (or the rear section). No user serviceable parts inside. Refer servicing to qualified personnel.

Caution

- To reduce the risk of fire or electric shock, do not expose this appliance to rain and moisture. The apparatus shall not be exposed to dripping or splashing liquids and no objects filled with liquids, such as vases, shall be placed on the apparatus.

Caution

- These service instructions are for use by qualified service personnel only. To reduce the risk of electric shock do not perform any servicing other than that contained in the operation instructions. Repairs have to be performed by qualified service personnel.

- 1) Read these instructions.
- 2) Keep these instructions.
- 3) Heed all warnings.
- 4) Follow all instructions.
- 5) Do not use this apparatus near water.
- 6) Clean only with dry cloth.
- 7) Do not block any ventilation openings. Install in accordance with the manufacturer's instructions.
- 8) Do not install near any heat sources such as radiators, heat registers, stoves, or other apparatus (including amplifiers) that produce heat.
- 9) Do not defeat the safety purpose of the polarized or grounding-type plug. A polarized plug has two blades with one wider than the other. A grounding-type plug has two blades and a third grounding prong. The wide blade or the third prong are provided for your safety. If the provided plug does not fit into your outlet, consult an electrician for replacement of the obsolete outlet.
- 10) Place the power cord so that it is protected from being walked on and sharp edges. Be sure that the power cord is protected particularly at plugs, convenience receptacles and the point where it exits from the apparatus.
- 11) The apparatus shall be connected to a MAINS socket outlet with a protective earthing connection.
- 12) Where the MAINS plug or an appliance coupler is used as the disconnect device, the disconnect device shall remain readily operable.
- 13) Use only attachments/accessories specified by the manufacturer.
- 14) Use only with the cart, stand, tripod, bracket, or table specified by the manufacturer, or sold with the apparatus. When a cart is used, use caution when moving the cart/apparatus combination to avoid injury from tip-over.



- 15) Unplug this apparatus during lightning storms or when unused for long periods of time.
- 16) Refer all servicing to qualified service personnel. Servicing is required when the apparatus has been damaged in any way, such as power supply cord or plug is damaged, liquid has been spilled or objects have fallen into the apparatus, the apparatus has been exposed to rain or moisture, does not operate normally, or has been dropped.



Foreword



Dear customer,
Welcome to the team of ULTRABASS users and thank you very much for expressing your confidence in BEHRINGER products by purchasing the BEHRINGER BVT4500H/BVT5500H.

Writing this foreword for you gives me great pleasure, because it represents the culmination of many months of hard work delivered by our engineering team to achieve a very ambitious goal: to present an outstanding bass workstation that gives you maximum flexibility and performance with its

unique sound character and broad range of functions.

The task of designing our new BVT4500H/5500H certainly meant a great deal of responsibility, which we assumed by focusing on you, the discerning user and musician. Meeting your expectations also meant a lot of work and night shifts. But it was fun, too. Developing a product usually brings a lot of people together. What a great feeling it is when all who participated in such a project can be proud of what they've achieved.

It is our philosophy to share our enjoyment with you, because you are the most important member of the BEHRINGER team. With your highly competent suggestions for new products you've made a significant contribution to shaping our company and making it successful. In return, we guarantee you uncompromising quality as well as excellent technical and audio properties at an extremely reasonable price. All of this will enable you to give free rein to your creativity without being hampered by budget constraints.

We are often asked how we manage to produce such high-quality devices at such unbelievably low prices. The answer is quite simple: it's you, our customers! Many satisfied customers mean large sales volumes, enabling us to get better purchasing terms for components, etc. Isn't it only fair to pass this benefit on to you? Because we know that your success is our success, too!

I would like to thank everyone who has made the BVT4500H/5500H possible. You have all made your own personal contributions, from the developers and the many other employees at this company, to you, the BEHRINGER user.

My friends, it's been worth the effort!

Thank you very much,

Uli Behringer

Table of contents

| | |
|--|-----------|
| 1. Introduction..... | 4 |
| 1.1 The Design Concept | 4 |
| 1.2 Before you get started | 4 |
| 1.2.1 Shipment..... | 4 |
| 1.2.2 Initial operation | 4 |
| 1.2.3 Online Registration | 4 |
| 2. Front panel | 5 |
| 3. Rear panel | 6 |
| 4. About speaker impedance..... | 7 |
| 5. Setup example | 8 |
| 6. The signal path | 8 |
| 6.1 INPUT | 8 |
| 6.2 TUNER..... | 8 |
| 6.3 LINE OUTPUT | 8 |
| 6.3.1 PRE | 8 |
| 6.3.2 POST | 8 |
| 6.4 EFFECTS LOOP..... | 8 |
| 6.4.1 SEND and RETURN..... | 8 |
| 6.4.2 SEND only (BVT5500H only)..... | 9 |
| 6.4.3 RETURN only | 9 |
| 6.5 INSERT CHANNEL | 9 |
| 6.5.1 PREAMP OUTPUT | 9 |
| 6.5.2 POWER AMP IN | 9 |
| 7. Audio connectors | 9 |
| 8. System block diagram | 10 |
| 9. Specifications | 11 |
| 10. Warranty | 12 |



1. Introduction

With the BVT4500H/5500H you have acquired a pro-level amplifier from our ULTRABASS series. This classic bass amp combines an uncompromising, "cutting-through" sound with a full range of sound-shaping features.

1.1 The Design Concept

Over the past few years, flexibility has become important. Bass players must now offer a broad range of sounds and play in different venues: home studios, professional studios, and live concerts. Additionally, the world of electric bass playing has changed. New effects devices and basses, with five or six strings, are launched all the time. There is also the desire to create one's own, "unique" sound—which can only be achieved with innovative amplifiers.

In response to these dual needs (flexibility and individuality), the BVT4500H/5500H offers you:

- ▲ TONE and GRAPHIC EQ features—for shaping and refining sound.
- ▲ VTC (Virtual Tube Circuitry)—adding the warmth of vintage tube circuitry to sound.
- ▲ Jacks for connecting the BVT4500H/5500H to effects processors, mixers/recording units, other preamps, and other power amps.
- ▲ 2 types of speaker jacks: ¼" TS and compatible with Neutrik Speakon connectors.

1.2 Before you get started

1.2.1 Shipment

Your product was carefully packed at the factory to ensure safe transport. Nevertheless, if the box is damaged inspect the unit immediately for signs of damage.

- ☞ **If the unit is damaged please do NOT return it to us, but notify your dealer and the shipping company immediately; otherwise, claims for damage or replacement may not be granted.**
- ☞ **We recommend that you use a flight case to give the unit optimum protection during use or transport.**
- ☞ **Always use the original box to prevent damage during storage or transport.**
- ☞ **Make sure that children cannot play unsupervised with the unit or its packaging.**
- ☞ **Please ensure proper disposal of all packing materials.**

1.2.2 Initial operation

Ensure adequate air supply and to avoid overheating do not place the unit near radiators etc.

Before you connect your BVT4500H/5500H to the mains, please make sure that your local voltage matches the voltage required by the unit.

CAUTION: The following applies only to BVT versions that can be switched between 120 V and 230 V: The fuse holder on the mains connector has 3 triangular markings. Two of these triangles opposing each other. The device is set to the operating voltage printed next to these markers and can be set to another voltage by turning the fuse holder by 180°.

- ☞ **Please note that when operating the unit at 120 V, a higher fuse rating is required. Blown fuses must be replaced by fuses of the correct rating!**
- ☞ **If you set the unit to a different mains voltage, be sure to use a fuse of the correct type and rating. Please refer to the "SPECIFICATIONS" for details.**

- ☞ **Blown fuses must be replaced by fuses of the correct rating! Please refer to the "SPECIFICATIONS" section for the applicable rating.**

CAUTION!

- ☞ **Before changing the fuse, switch off the device and pull the plug to avoid electric shock or damage to the device.**

For connection to the mains use the enclosed power cord with cold connector which complies with the relevant safety regulations.

- ☞ **Please make sure that all devices are properly grounded. For your own safety, never remove or disable the ground conductors from the devices or on the power cords. The unit must always be connected to the mains outlet with a protective grounding connection.**

- ☞ **Please ensure that only qualified personnel install and operate the BVT4500H/BVT5500H. During installation and operation the user must have sufficient electrical contact to earth. Electrostatic charges might affect the operation of the unit.**

WARNING!

- ☞ **Extreme output volumes may damage your hearing and/or your loudspeakers. Turn down all volume and level controls before you switch on the unit. Always set the volume to an appropriate level.**

Important notes concerning installation

- ☞ **The sound quality may diminish within the range of powerful broadcasting stations and high-frequency sources. Increase the distance between the transmitter and the device and use shielded cables for all connections.**

1.2.3 Online Registration

Please register your new BEHRINGER equipment right after your purchase by visiting <http://www.behringer.com> and read the terms and conditions of our warranty carefully.

Should your BEHRINGER product malfunction, it is our intention to have it repaired as quickly as possible. To arrange for warranty service, please contact the BEHRINGER retailer from whom the equipment was purchased. Should your BEHRINGER dealer not be located in your vicinity, you may directly contact one of our subsidiaries. Corresponding contact information is included in the original equipment packaging (Global Contact Information/ European Contact Information). Should your country not be listed, please contact the distributor nearest you. A list of distributors can be found in the support area of our website (<http://www.behringer.com>).

Registering your purchase and equipment with us helps us process your repair claims more quickly and efficiently.

Thank you for your cooperation!

2. Front panel

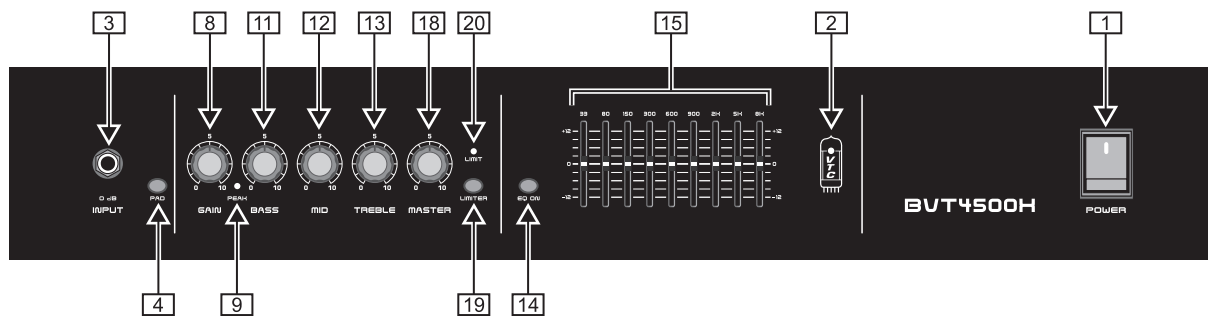

Fig. 2.1: BVT4500H front panel

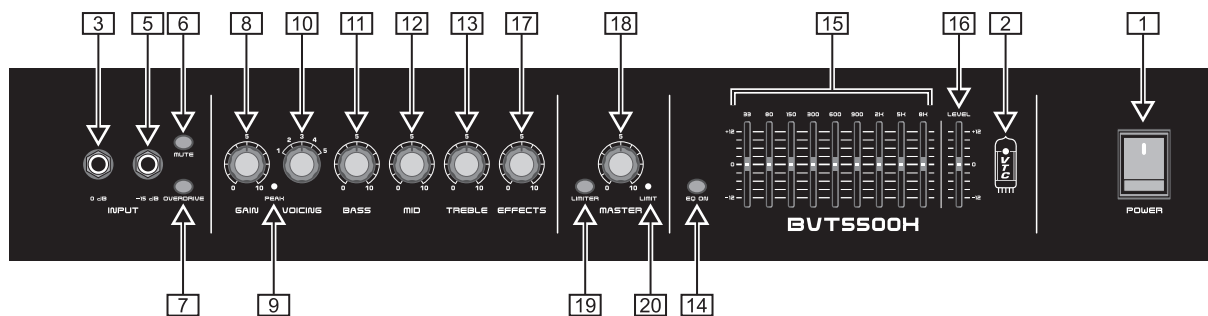

Fig. 2.2: BVT5500H front panel

This section describes how to use the front panel of the BVT4500H and the BVT5500H, illustrated on the previous page and above.

1 **POWER** switch: Use the **POWER** switch to turn on your BVT4500H/5500H. The **POWER** switch should always be in the "Off" position when you are about to connect your unit to the wall socket or disconnect it.

Switch-on thumps can damage your hearing and your speakers. Before you connect the BVT to the mains, ensure that it is turned off.

2 **VTC** LED: When the BVT is off, this LED is not illuminated. When it is on, this LED is illuminated and indicates that the amp is activated for use. VTC is BEHRINGER's analog technology that emulates the warmth of vintage tube circuitry.

INPUT features

To input an audio signal to the BVT, use features **3** - **7**, as follows:

3 **0 dB** jack: To connect an electric bass to the BVT, use this 1/4" mono jack (unbalanced). Basses with active pickups create high-level signals.

If your bass includes an active pickup and you work with:

- ▲ the BVT4500H, use the **PAD** button **4** to reduce the input audio signal.
- ▲ the BVT5500H, use the **-15 dB** jack **5** instead of the **0 dB** jack.

4 **PAD** button (BVT4500H only): If the **PEAK** LED **9** constantly illuminates and the **GAIN** control **8** is set to 0 (zero), the input level of the audio signal is too high. In this case, press this button to activate the pad. The pad reduces the input sensitivity by 15 dB.

5 **-15 dB** jack (BVT5500H only): To connect an active bass to the BVT5500H, use this 1/4" mono jack (unbalanced). Using this jack will give you a lower input sensitivity as compared with the **0 dB** jack.

6 **MUTE** button (BVT5500H only): Use this button if you want to tune a bass without hearing the tone. This feature mutes the main signal path, but not the **TUNER** output.

7 **OVERDRIVE** button (BVT5500H only): Use this button to add a distorted texture to the audio signal. This feature "overdrives" the BVT5500H preamp.

8 **GAIN** control: Use this control to boost or cut the level of the input signal.

9 **PEAK** LED: At various points in the signal path, the BVT monitors the level of the audio signal. When the level is too high, the **PEAK** LED warns that clipping can occur.

If the LED:

- ▲ occasionally illuminates, the BVT clips only some peaks in the audio signal. Occasional clipping does not reduce the sound quality and shows that the signal is strong enough.
- ▲ never illuminates, the BVT does not clip any signal peaks in the audio signal. The audio signal is probably too weak to make use of the full dynamic range. Increase the **GAIN** **8** setting until the **PEAK** LED lights up only occasionally, at the strongest signal peaks.
- ▲ constantly illuminates, the BVT clips a large part of the audio signal and you will hear a distortion. Lower the **GAIN** setting and check for extreme fader or control settings.

TONE features

"Tone" refers to the presence and quality of these frequency bands of an audio signal:

- ▲ bass: from 30 to 200 Hz
- ▲ mid-range: from 200 to 2 000 Hz
- ▲ treble: from 2 000 Hz to 20 kHz

The BVT offers controls to effectively tailor the sounds to your needs by cutting or boosting specific bands. To adjust the tone, use features **10** - **13**, as follows:

10 **VOICING** control (BVT5500H only): To select the tone you want, turn this knob to one of the following presets.

The BVT5500H equalizes the audio signal for you.

- ▲ 1: Prominent bass and treble tones (scooped mids).
- ▲ 2: Smooth and warm treble tones (passive tone).
- ▲ 3: Flat, natural bass tones (no equalization).
- ▲ 4: Bright treble tones.
- ▲ 5: Flat, natural bass tones that are not muddy (bass rolloff).

11 - **13** **BASS**, **MID**, and **TREBLE** controls: For each tone (bass, mid-range, and treble) that you can emphasize or de-emphasize, the BVT includes a single **TONE** control.

ULTRABASS BVT4500H/BVT5500H

To emphasize a tone, you can turn the relevant tone control toward 10 (maximum boost). Alternatively, you might consider lowering adjacent bands. To de-emphasize a tone, you can turn the relevant tone control toward 0 (maximum cut).

When you choose to cut rather than boost an audio signal, you protect audio equipment from high signal levels (clipping) and preserve valuable headroom.

GRAPHIC EQ features

With the TONE controls (10 - 13) discussed above, you emphasize and de-emphasize three fairly wide frequency bands. However, with the GRAPHIC EQ features, you can emphasize and de-emphasize 9 more narrow frequency bands. This lets you refine the sound that you created with the TONE controls. The GRAPHIC EQ features include 14-16:

14 EQ ON button: To turn graphic EQ and level features, push this button.

15 EQ faders: If you activated the frequency-band faders 14, you can use each one to emphasize and de-emphasize a specific frequency band. The center frequency of each frequency band is displayed directly above the relevant fader.

To emphasize (boost) a frequency band, slide the relevant fader up. Alternatively, slide the faders for the surrounding frequency bands down.

To de-emphasize (cut) a frequency band, slide the relevant fader down. Alternatively, slide the faders for the surrounding frequency bands up.

Cutting rather than boosting a frequency band protects audio equipment from high signal levels (clipping) and preserves valuable headroom.

16 LEVEL fader (BVT5500H only): To compensate possible level changes of the equalized signal, slide this control between +12 and -12. At "0" level, the BVT5500H neither boosts nor cuts the equalized signal.

17 EFFECTS MIX control (BVT5500H only): If you created an effects loop, use this control to adjust the *dry-wet* mix.

As you turn this control toward:

▲ 0 (zero), you hear more of the *dry* signal (without effects). At zero, you hear only the dry signal.

▲ 10, you hear more of the *wet* signal (effects). At 10, you hear only the wet signal.

For details about creating an effects loop, see 3. REAR PANEL (29 - 30).

MASTER features

18 MASTER control: To adjust the speaker volume and the level of the PREAMP OUTPUT, turn this control toward 0 (no volume/level) or, alternatively 10 (maximum volume/level).

19 LIMITER button: The limiter reduces only the signal peaks that can overdrive the POWER AMP and distort the audio signal. The limiter prevents the BVT4500H/5500H from clipping these signal peaks. To activate or alternatively deactivate the limiter, push this button.

Because high signal peaks can damage loudspeakers, it is recommended to activate the limiter and not to play at full volume for a long time without ear protection.

20 LIMIT LED: When the limiter is activated, this LED is illuminated.

3. Rear panel

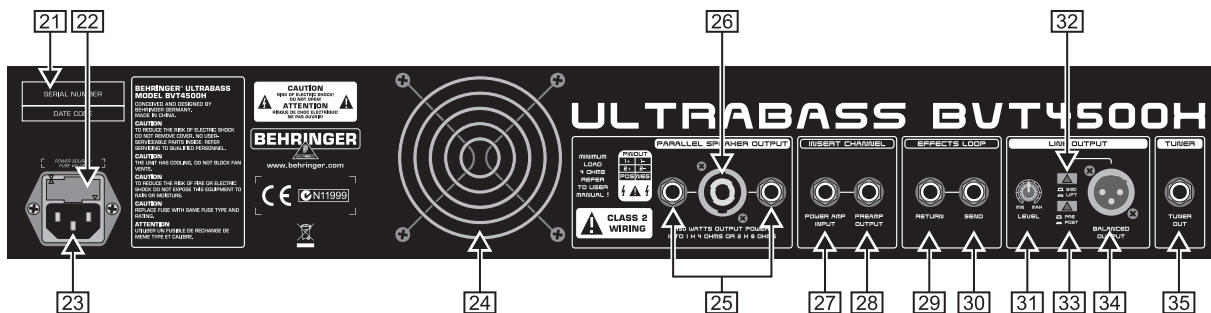

Fig. 3.1: BVT4500H/BVT5500H rear panel

This chapter describes how to use the rear panel of the BVT4500H and the BVT5500H, which includes the same features. Figure 3.1 illustrates these features.

To effectively use the jacks on the rear panel, you need to know about the BVT signal path. For details, refer to the section "THE SIGNAL PATH".

21 Serial number: To register your unit, you will need this unique identifier.

22 Fuse compartment: For details about the appropriate fuse type, refer to the "SPECIFICATIONS". See also chapter 1.1.2. Replace this fuse only with the type specified for your country.

23 Power connector: To power the BVT4500H/5500H, plug the power cord in this AC connector. The power cord comes with the BVT.

Attention: The POWER switch does not fully disconnect the unit from the mains. Unplug the power cord completely when the unit is not used for prolonged periods of time.

24 Fan: This fan prevents the BVT4500H/5500H from overheating.

Do not block the ventilation openings that cover the fan.

PARALLEL SPEAKER OUTPUT

Via the following jacks, you can simultaneously connect up to 3 speakers directly to the BVT:

25 Two 1/4" TS (mono, unbalanced) jacks.

26 A single Neutrik Speakon compatible jack, for high-power loudspeakers. The pin designation of the speaker is pins 1+ and 1-. For details, refer to the chapter "AUDIO CONNECTORS".

If you use a single speaker or a high-power speaker, connect this speaker to the Neutrik Speakon compatible jack. To prevent electrical shock and ensure the correct polarity, this jack locks an audio plug in place.

Before you connect speakers to the BVT4500H/5500H, turn it off.

 Your speaker cabinets should have a sufficient power rating (BVT4500H: > 450 W, BVT5500H: > 550 W) and preferably a total impedance of 4 Ω or higher. Too high a load impedance will decrease the output power rating of the power stage. For details, refer to the chapter “ABOUT SPEAKER IMPEDANCE”.

[27] **POWER AMP INPUT:** To connect an external preamplifier to the BVT, use this ¼" TS jack.

[28] **PREAMP OUTPUT:** To connect an external power amplifier to the BVT, use this ¼" TS jack.

EFFECTS LOOP jacks

To connect the BVT4500H/5500H to an effects processor you can use one or, alternatively both of these jacks ([29]- [30]). Keep in mind that the BVT4500H and the BVT5500H do not process effects in the same way. For details, see “THE SIGNAL PATH”.

[29] **RETURN** jack: To send an audio signal from an effects processor to the BVT, use this ¼" TS jack.

[30] **SEND** jack: To send an audio signal from the BVT to an effects processor, use this ¼" TS jack.

LINE OUTPUT features

To send an audio signal from the BVT to a mixer or a recording unit, use the LINE OUTPUT features ([31] - [34]), as follows:

[31] **LEVEL** control: To adjust the level of any LINE OUTPUT, turn this knob toward min (no level) or, alternatively max.

The value of the max setting depends on what you selected via the PRE/POST button [33]. If you selected:

▲ **PRE:** max is ~ 0 dB.

▲ **POST:** max is ~ 10 dB.

[32] **GND LIFT** button: To manage the ground connection between the BVT and a mixer/recording unit, use this button.

When this button is:

▲ pushed out, you maintain a ground connection that prevents electrostatic charges from interfering with an audio signal.

▲ pushed in, you break the ground connection. Do this only when ground-loop hum interferes with an audio signal.

[33] **PRE/POST** button: To select the type of signal you want to send to a mixer/recording unit, use this button.

When this button is:

▲ pushed out (PRE EQ and effects), the BVT does not apply any preamp features (TONE/EQ/EFFECTS) to the audio signal.

▲ pushed in (POST EQ and effects), the BVT applies all preamp features to the audio signal.

For details, see “THE SIGNAL PATH”.

[34] **BALANCED OUTPUT:** To connect the BVT to the mic input on a mixer or, alternatively to a recording unit, use this XLR jack (balanced).

 **Before you connect the BVT4500H/5500H to mic input on a mixer, turn off the phantom power on the relevant channel of the mixer.**

[35] **TUNER OUT** jack: To connect the BVT4500H/5500H to an electronic tuner, use this ¼" TS jack.

To tune while muting the PARALLEL SPEAKER OUTPUTs, do one of the following. If you work with:

▲ the BVT4500H, turn the **MASTER** control to 0 (minimum setting).

Alternatively, you can use the tuner’s mute feature: Connect **EFFECTS SEND** [30] to the tuner input and **EFFECTS RETURN** [29] to the tuner output. When you:

▲ activate the mute feature on the tuner, the tuner does not send the audio signal to the **RETURN** jack.

▲ deactivate the mute feature on the tuner, the tuner sends the audio signal to the **RETURN** jack. The audio signal follows the signal path to the **PARALLEL SPEAKER OUTPUTs**.

▲ the BVT5500H, activate the mute feature [6].

4. About speaker impedance

The total impedance of the speakers that you connect to the BVT affects the power output of the BVT. The minimum speaker impedance is 4 Ω. When the total load is 4 Ω, the BVT supplies the optimal power.

How to calculate the speaker impedance

When using more than one speaker and each connecting to another BVT speaker jack, the speakers are connected in parallel. To calculate the resulting total impedance of the speakers, use the following formula—

$$Z_{\text{total}} = \frac{1}{1/Z_1 + 1/Z_2 + \dots}$$

—where Z_1 , Z_2 etc. are each the impedance of a single speaker and Z_{total} is the resulting impedance of all speakers.

For two speakers (Z_1 and Z_2), the formula reads as:

$$Z_{\text{total}} = \frac{Z_1 \cdot Z_2}{Z_1 + Z_2}$$

Via the formula, you get a 4 Ω load with:

- ▲ one 4 Ω speaker
- ▲ two 8 Ω speakers
- ▲ one 8 Ω speaker and two 16 Ω speakers

 **As the speaker impedance decreases, the output power of the BVT increases. High output power can damage your speakers. As the speaker impedance increases, the output power of the BVT decreases.**

5. Setup example

The following illustration provides an example of how to set up the BVT5500H.

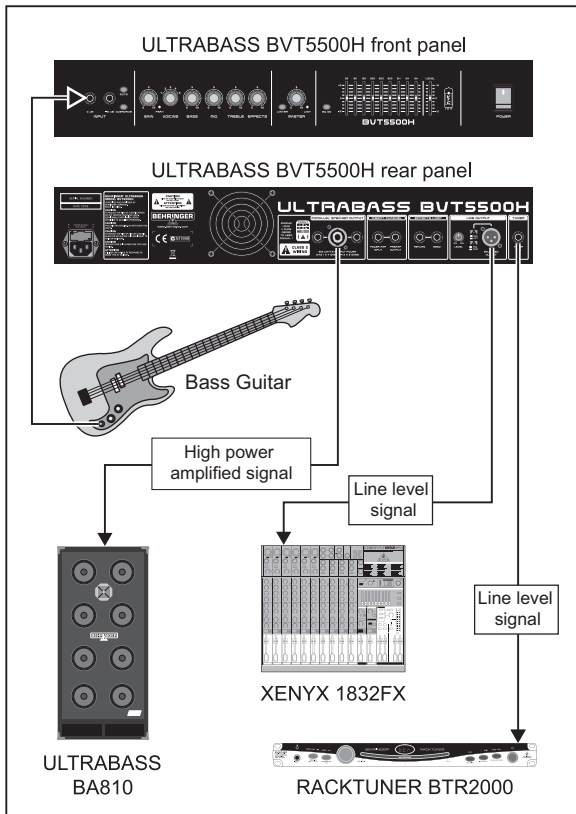

Fig. 5.1: BVT5500H setup example

In the above example,

- ▲ a speaker (ULTRABASS BA810),
- ▲ a mixer (XENYX 1832FX),
- ▲ and a tuner (RACKTUNER BTR2000)

are simultaneously connected to the BVT5500H.

However, you can tune without adjusting the speaker volume. For details, see "FRONT PANEL" (*MUTE* button [8]) and "REAR PANEL" (*TUNER* jack [35]).

The audio signals that the ULTRABASS BA810 and the XENYX 1832FX receive from the BVT5500H are not the same:

- ▲ The ULTRABASS BA810 receives a fully amplified signal.
- ▲ The XENYX 1832FX receives a preamplified (line-level) signal.

You can select the type of preamplified signal (PRE or POST TONE/EQ/EFFECTS) that the BVT5500H sends. For details, see "THE SIGNAL PATH".

6. The signal path

This section provides what you need to know to effectively use the BVT control elements and connection jacks. For an overview of the possible paths your signal may take, refer to the illustration in the section "SYSTEM BLOCK DIAGRAM".

In general, the signal path of the BVT can be split into two phases:

- 1) Pre-Amplification, which starts at the *INPUT* jack ([3], [5]) and ends immediately at the *PREAMP OUTPUT* jack [28].
- 2) Power amplification, which starts at the *POWER AMP IN* jack [27] and ends at the *PARALLEL SPEAKER OUTPUT* jacks ([25], [26]).

Note that only the *PARALLEL SPEAKER OUTPUTS* carry a fully amplified signal while the other output jacks carry line-level signals.

The rest of this section covers all BVT jacks and ways to connect your equipment to them.

6.1 INPUT

PURPOSE: To send an audio signal from an electric bass to the BVT.

RESULTS: The signal path begins at the *INPUT* jack.

6.2 TUNER

PURPOSE: To send a copy of an audio signal from the BVT to an electric tuner.

RESULTS: The main signal path is not affected.

If you use the:

- ▲ BVT4500H, you can reduce the volume of the *PARALLEL SPEAKER OUTPUTS* or use the mute feature on your tuner. For details, see *TUNER* jack [35].
- ▲ BVT5500H, you can mute the *PARALLEL SPEAKER OUTPUTS* and the *LINE OUTPUT*. For details, see *MUTE* button [6].

6.3 LINE OUTPUT

The characteristic of the signal at the *LINE OUTPUT* jack depends on the state of the *PRE/POST* switch.

6.3.1 PRE

PURPOSE: To send a copy of an audio signal to a mixer or a recording unit without any preamp settings (TONE, EQ, EFFECTS). See also section 6.3.2.

RESULTS: The main signal path is not affected.

6.3.2 POST

PURPOSE: To process an audio signal with all BVT preamp features (TONE, EQ, EFFECTS), and then send the preamplified signal to a mixer or, alternatively a recording unit.

Notice that the *LINE OUTPUT* jack (with POST) derives the signal before the *MASTER* control. This means the output level of this jack is independent of the actual amplifier volume.

Keep in mind that you can activate and deactivate the EQ section. In addition, the BVT4500H and BVT5500H do not process external effects in the same way. For details, see the section "EFFECTS LOOP".

RESULTS: The main signal path is not affected.

6.4 EFFECTS LOOP

The EFFECTS LOOP section can be used in three ways:

6.4.1 SEND and RETURN

PURPOSE: To create an effects loop, i.e., to apply external effects to the signal.

RESULTS: If you use the:

- ▲ BVT4500H, only the audio signal that enters via the *RETURN* jack continues to follow the BVT4500H signal path. The level of the effects has to be adjusted on the external unit.
- ▲ BVT5500H, both the main audio signal and the audio signal that enters via the *RETURN* jack follow the BVT5500H signal path. To adjust the dry-wet mix, use the *EFFECTS MIX* control.

6.4.2 SEND only (BVT5500H only)

PURPOSE: To send an audio signal from the BVT5500H to an effects processor.

RESULTS: The main signal path is not affected.

6.4.3 RETURN only

PURPOSE: To send an audio signal from an external pre-amp to the BVT4500H/5500H, i.e., to use the BVT as a power amp only.

RESULTS: If you use the:

- ▲ BVT4500H, the *INPUT* jack is deactivated. The signal path begins at the *RETURN* jack.
- ▲ BVT5500H, the *INPUT* jack remains active. You could e.g., connect two basses to the BVT, one to *INPUT* and the other to *RETURN*. To adjust the balance between the two, use the *EFFECTS MIX* control.

6.5 INSERT CHANNEL

6.5.1 PREAMP OUTPUT

PURPOSE: To process an audio signal with all BVT preamp features (TONE, EQ, EFFECTS), and then send the audio signal to an external power amp. The BVT settings affect the volume on the external amp.

RESULTS: The main signal path is not affected.

6.5.2 POWER AMP IN

PURPOSE: To process an audio signal with an external preamp, and then send the audio signal to the BVT4500H/5500H power amp.

RESULTS: The signal path begins at the *POWER AMP IN* jack. The signal is independent of the *MASTER* control.

🔌 **Switch off the unit before connecting an external preamp to *POWER AMP IN*.**

7. Audio connectors

This section illustrates the audio connectors that you need for the BVT jacks. For details about most BVT jacks, see the section "REAR PANEL". For details about the *INPUT* jack, see the section "FRONT PANEL".

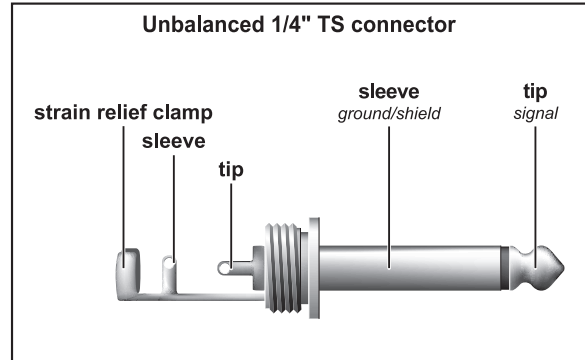

Fig. 7.1: 1/4" TS connector

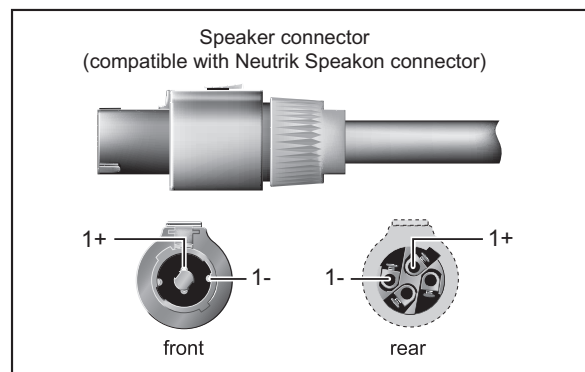

Fig. 7.2: The connector for a Neutrik Speakon compatible jack

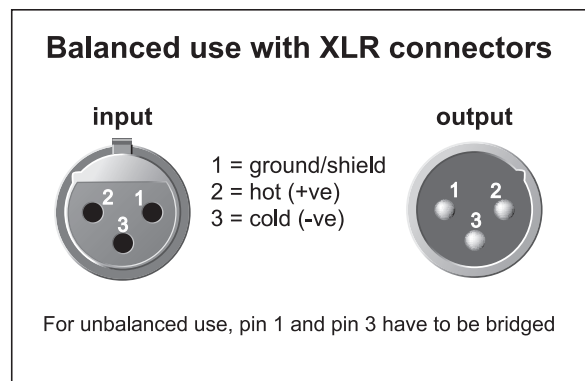

Fig. 7.3: XLR connectors

8. System block diagram

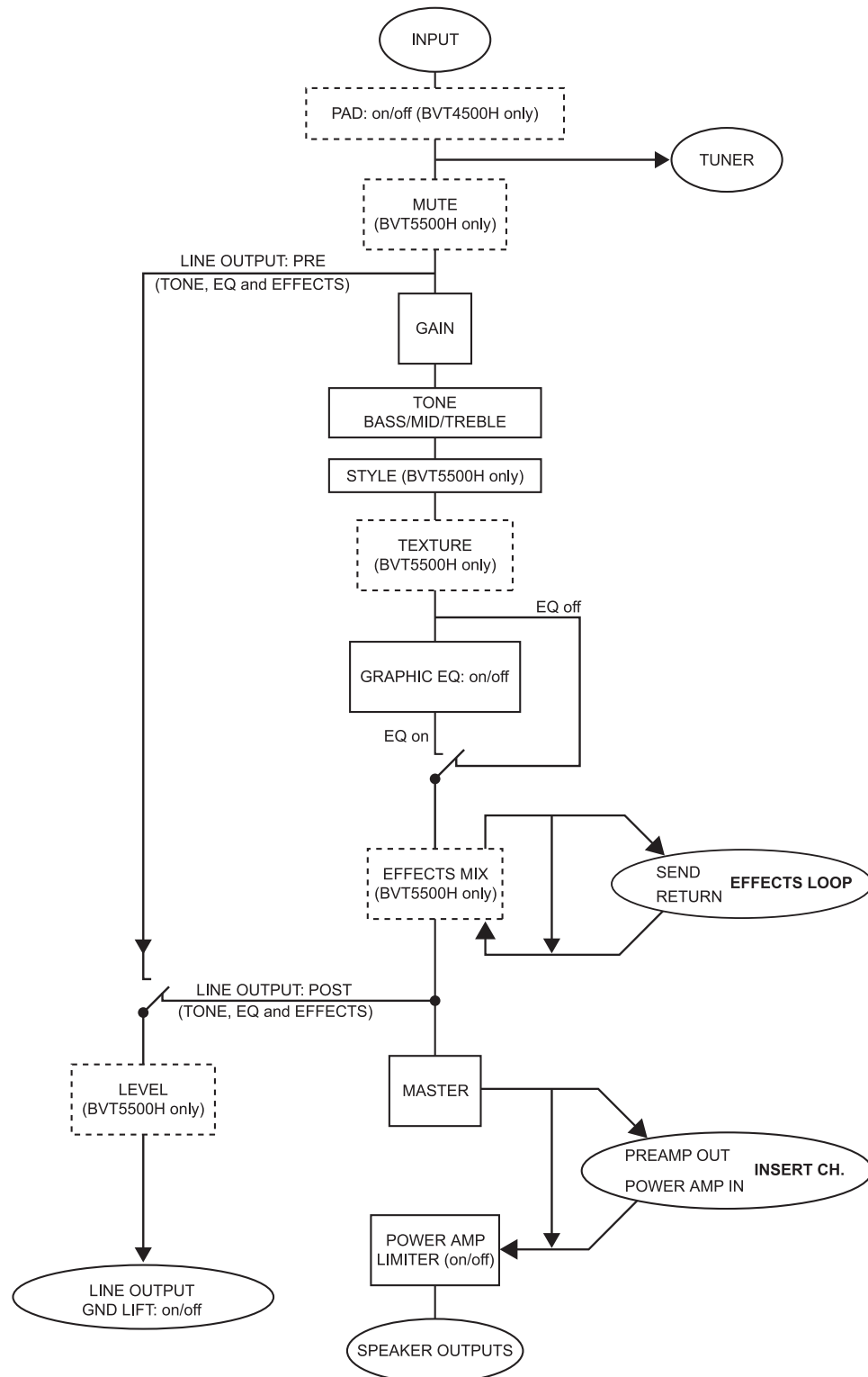

Fig. 8.1: BVT4500/5500H block diagram (Rectangles represent control elements, ovals represent jacks.)

9. Specifications

Audio Inputs

BVT4500H

| | |
|-----------------|--|
| Input | ¼" mono jack, unbalanced (0 dB) |
| Input impedance | approx. 1 MΩ, unbalanced (pad 82 kΩ, unbalanced) |
| Return | ¼" mono jack, unbalanced |
| Input impedance | approx. 100 kΩ, unbalanced |
| Power amp input | ¼" mono jack, unbalanced |
| Input impedance | approx. 100 kΩ, unbalanced |

BVT5500H

| | |
|-----------------|--|
| Input | 2 x ¼" mono jack, unbalanced (0 dB / -15 dB) |
| Input impedance | approx. 1 MΩ, unbalanced / 82 kΩ, unbalanced |
| Return | ¼" mono jack, unbalanced |
| Input impedance | approx. 100 kΩ, unbalanced |
| Power amp input | ¼" mono jack, unbalanced |
| Input impedance | approx. 100 kΩ, unbalanced |

Audio Outputs

| | |
|------------------------|---|
| Loudspeaker connectors | 2 x ¼" TS jack, 1 x professional speaker connector (compatible with Neutrik Speakon connectors) |
| Load impedance | min. 4 Ω |

System data

BVT4500H

Output power

| | |
|------------|-------|
| Peak power | 450 W |
|------------|-------|

Tone control range

| | |
|--------|----------------|
| Bass | ±12 dB @ 50 Hz |
| MID | ±7 dB @ 700 Hz |
| Treble | ±18 dB @ 5 kHz |

Graphic EQ range

| | |
|--------|--------|
| 33 Hz | ±15 dB |
| 80 Hz | ±10 dB |
| 150 Hz | ±8 dB |
| 300 Hz | ±8 dB |
| 600 Hz | ±8 dB |
| 900 Hz | ±8 dB |
| 2 kHz | ±8 dB |
| 5 kHz | ±10 dB |
| 8 kHz | ±12 dB |

BVT5500H

Output power

| | |
|------------|-------|
| Peak power | 550 W |
|------------|-------|

Tone control range

| | |
|--------|---------------------------------|
| Bass | ±12 dB @ 50 Hz |
| MID | +7 dB @ 800 Hz / -7 dB @ 400 Hz |
| Treble | ±18 dB @ 5 kHz |

Graphic EQ range

| | |
|--------|--------|
| 33 Hz | ±15 dB |
| 80 Hz | ±10 dB |
| 150 Hz | ±8 dB |
| 300 Hz | ±8 dB |
| 600 Hz | ±8 dB |
| 900 Hz | ±8 dB |
| 2 kHz | ±8 dB |
| 5 kHz | ±10 dB |
| 8 kHz | ±12 dB |

Power supply

BVT4500H

| | |
|-------------------|---|
| Power consumption | 100 V~ 50/60 Hz: 6 A; 120 V~ 60 Hz: 5 A; 220 V~ 50/60 Hz: 3 A; 230 V~ 50/60 Hz: 3 A |
|-------------------|---|

Mains voltage / Fuse

| | |
|-----------------------|-------------------------|
| 100/120 V~ (50/60 Hz) | T 10 A H 250 V |
| 220/230 V~ (50/60 Hz) | T 6.3 A H 250 V |
| Mains connector | Standard IEC receptacle |

BVT5500H

| | |
|-------------------|------------|
| Power consumption | max. 550 W |
|-------------------|------------|

Mains voltage / Fuse

| | |
|-----------------------|-------------------------|
| 100/120 V~ (50/60 Hz) | T 8 A H 250 V |
| 220/230 V~ (50/60 Hz) | T 4 A H 250 V |
| Mains connector | Standard IEC receptacle |

Physical/weight

BVT4500H

| | |
|------------------------|--|
| Dimensions (H x W x D) | approx. 26.8" x 16.1" x 13.7" (approx. 680 mm x 408 mm x 348 mm) |
| Weight | approx. 47.5 lbs (approx. 21.5 kg) |

BVT5500H

| | |
|------------------------|--|
| Dimensions (H x W x D) | approx. 26.8" x 16.1" x 13.7" (approx. 680 mm x 408 mm x 348 mm) |
| Weight | approx. 47.9 lbs (approx. 21.7 kg) |

BEHRINGER is constantly striving to maintain the highest professional standards. As a result of these efforts, modifications may be made from time to time to existing products without prior notice. Specifications and appearance may differ from those listed or illustrated.

10. Warranty

§ 1 Other warranty rights and national law

1. This warranty does not exclude or limit the buyer's statutory rights provided by national law, in particular, any such rights against the seller that arise from a legally effective purchase contract.
2. The warranty regulations mentioned herein are applicable unless they constitute an infringement of national warranty law.

§ 2 Online registration

Please do remember to register your new BEHRINGER equipment right after your purchase by visiting <http://www.behringer.com> and kindly read the terms and conditions of our warranty carefully. Registering your purchase and equipment with us helps us process your repair claims quicker and more efficiently.

Thank you for your cooperation!

§ 3 Warranty

1. BEHRINGER (BEHRINGER International GmbH including all BEHRINGER subsidiaries, except BEHRINGER Japan) warrants the mechanical and electronic components of this product to be free of defects in material and workmanship for a period of one (1) year* from the original date of purchase, in accordance with the warranty regulations described below. If the product shows any defects within the specified warranty period that are not excluded from this warranty as described under § 5, BEHRINGER shall, at its discretion, either replace the product by providing a new or reconditioned product or repair the product using suitable new or reconditioned parts. In the case that other parts are used which constitute an improvement, BEHRINGER may, at its discretion, charge the customer for the additional cost of these parts. In case BEHRINGER decides to replace the product, this warranty shall apply to the replacement product for the remaining initial warranty period, i.e. one year* from the date of purchase of the initial product.
2. If the warranty claim proves to be justified, the product will be returned to the user freight prepaid.
3. Warranty claims other than those indicated above are expressly excluded.

§ 4 Return authorization number

1. To obtain warranty service, the buyer (or his authorized dealer) must call BEHRINGER during normal business hours BEFORE returning the product. All inquiries must be accompanied by a description of the problem. The buyer or his authorized dealer will receive a return authorization number.
2. Subsequently, the product must be returned in its original shipping carton, together with the return authorization number. The return shipment address will be indicated by BEHRINGER.
3. Shipments without freight prepaid will not be accepted.

§ 5 Warranty regulations

1. Warranty services will be furnished only if the product is accompanied by a copy of the original retail dealer's invoice. Any product deemed eligible for repair or replacement under the terms of this warranty will be repaired or replaced.

2. If the product needs to be modified or adapted in order to comply with applicable technical or safety standards on a national or local level, in any country which is not the country for which the product was originally developed and manufactured, this modification/adaptation shall not be considered a defect in materials or workmanship. The warranty does not cover any such modification/adaptation, irrespective of whether it was carried out properly or not. Under the terms of this warranty, BEHRINGER shall not be held responsible for any cost resulting from such a modification/adaptation.

3. Free inspections and maintenance/repair work are expressly excluded from this warranty, in particular, if caused by improper handling of the product by the user. This also applies to defects caused by normal wear and tear, in particular, of faders, crossfaders, potentiometers, keys/buttons, tubes, guitar strings, illuminants and similar parts.

4. Damage/defects caused by the following conditions are not covered by this warranty:

- ▲ improper handling, neglect or failure to operate the unit in compliance with the instructions given in BEHRINGER user or service manuals.
- ▲ connection or operation of the unit in any way that does not comply with the technical or safety regulations applicable in the country where the product is used.
- ▲ damage/defects caused by force majeure or any other condition that is beyond the control of BEHRINGER.

5. Any repair or opening of the unit carried out by unauthorized personnel (user included) will void the warranty.

6. If an inspection of the product by BEHRINGER shows that the defect in question is not covered by the warranty,

7. Products which do not meet the terms of this warranty will be repaired exclusively at the buyer's expense. BEHRINGER will inform the buyer of any such circumstance. If the buyer fails to submit a written repair order within 6 weeks after notification, BEHRINGER will return the unit. Costs for freight and packing will be invoiced separately C.O.D. When the buyer has sent in a written repair order such costs will also be invoiced separately.

§ 6 Warranty transferability

This warranty is extended exclusively to the original buyer (customer of retail dealer) and is not transferable to anyone who may subsequently purchase this product. No other person (retail dealer, etc.) shall be entitled to give any warranty promise on behalf of BEHRINGER.

§ 7 Claim for damages

Failure of BEHRINGER to provide proper warranty service shall not entitle the buyer to claim (consequential) damages. In no event shall the liability of BEHRINGER exceed the invoiced value of the product.

* Customers in the European Union please contact BEHRINGER Germany Support for further details.

Technical specifications and appearance are subject to change without notice. The information contained herein is correct at the time of printing. BEHRINGER accepts no liability for any loss which may be suffered by any person who relies either wholly or in part upon any description, photograph or statement contained herein. Colors and specifications may vary slightly from product. Our Products are sold through authorized dealers only. Distributors and dealers are not agents of BEHRINGER and have absolutely no authority to bind BEHRINGER by any express or implied undertaking or representation. This manual is copyrighted. No part of this manual may be reproduced or transmitted in any form or by any means, electronic or mechanical, including photocopying and recording of any kind, for any purpose, without the express written permission of BEHRINGER International GmbH.

ALL RIGHTS RESERVED. © 2007 BEHRINGER International GmbH, Hanns-Martin-Schleyer-Str. 36-38, 47877 Willich-Muenchheide II, Germany. Tel. +49 2154 9206 0, Fax +49 2154 9206 4903

Free Manuals Download Website

<http://myh66.com>

<http://usermanuals.us>

<http://www.somanuals.com>

<http://www.4manuals.cc>

<http://www.manual-lib.com>

<http://www.404manual.com>

<http://www.luxmanual.com>

<http://aubethermostatmanual.com>

Golf course search by state

<http://golfingnear.com>

Email search by domain

<http://emailbydomain.com>

Auto manuals search

<http://auto.somanuals.com>

TV manuals search

<http://tv.somanuals.com>