

**GAS OVEN
FOUR A GAZ**

**GG 15112 GX
GG 15112 GW
GG 15112 GB**

BEKO

**Instruction manual
Manuel d'utilisation**

Please read these instructions before installation or using your appliance!

Dear Customer,

By purchasing this product you have chosen an appliance of advanced technology and high quality.

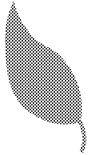

The appliance was produced in modern facilities which meet all environmental standards.

The instructions will help you to operate the appliance quickly and safely.

- Upon delivery, please check that the appliance is not damaged. If you note any transport damage, please contact your point of sale immediately and do not connect and operate the appliance!
- Before you connect and start using the appliance, please read this manual and all enclosed documents. Please note in particular the safety instructions.
- Keep all documents so that you can refer to the information again later on. Please keep your receipt for any repairs which may be required under warranty.
- When you pass on the appliance to another person, please provide all documents with it.

Table of Contents

1 General information 4

Overview	4
Technical Data	5
Accessories supplied with the unit	6
Injector Table	6

2 Safety Instructions 7

Explanation of safety instructions	7
Basic safety instructions	7
Safety for children	8
Safety when working with gas	8
Safety when working with electricity	9
Intended use	10
Disposal	10
Packaging material	10
Old equipment	10
Future transportation	10

3 Installation 11

Before installation	11
Installation and connection	13
Gas conversion	16

4 Preparation 19

Tips for saving energy	19
Initial operation	19

First cleaning of the appliance	19
Initial heating	19

5 How to use the hob 21

General information on cooking	21
How to use hobs	21

6 How to Operate the Oven 23

General information on baking, roasting and grilling	23
How to use the gas oven	24
Cooking times table	25
How to operate the gas grill	26
Cooking times table	27
How to use the alarm clock	28

7 Maintenance and Care 29

General information	29
How to clean the hob	29
Cleaning the control panel	29
Cleaning the oven	29
Removal of oven door	30
Taking off the door inner glass	30
Replacing the oven lamp	31

8 Troubleshooting 32

1 General information

Overview

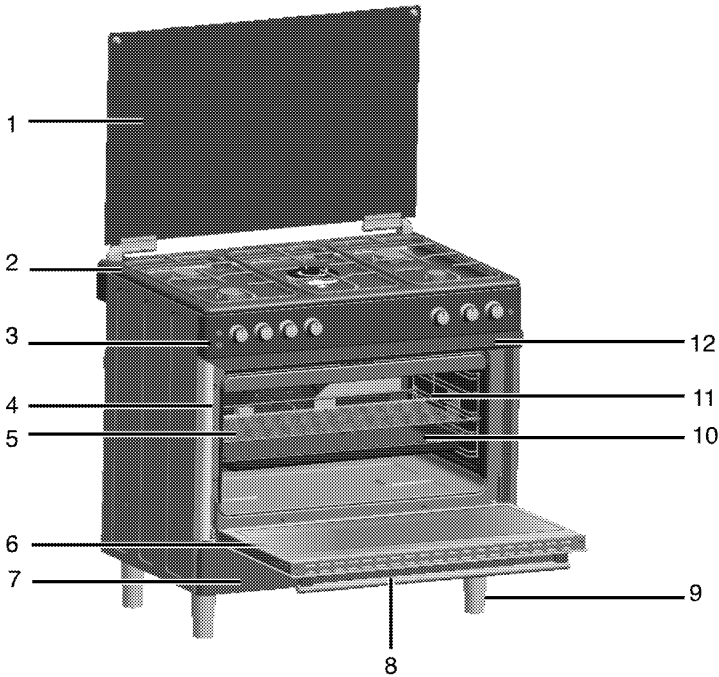

- | | | | |
|---|-----------------|----|-----------------------|
| 1 | Top lid | 7 | Storage Compartment |
| 2 | Burners' plate | 8 | Handle |
| 3 | Control panel | 9 | Foot |
| 4 | Shelf positions | 10 | Tray |
| 5 | Wire shelf | 11 | Turnspit |
| 6 | Front door | 12 | Knob protection sheet |

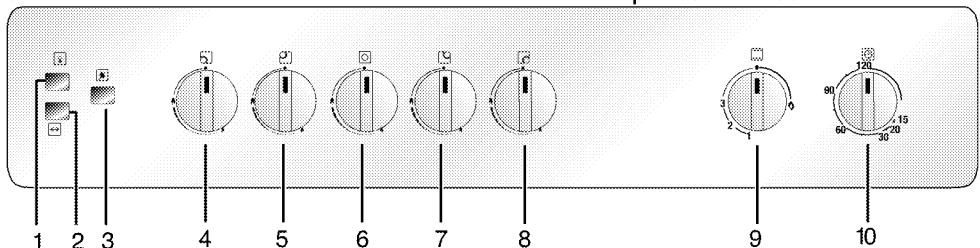

- | | | | |
|---|--------------------------|----|------------------------------|
| 1 | Lamp button | 6 | Wok burner Middle |
| 2 | Turnspit button | 7 | Rapid burner Rear right |
| 3 | Ignition button | 8 | Auxiliary burner Front right |
| 4 | Normal burner Rear left | 9 | Oven knob |
| 5 | Normal burner Front left | 10 | Mechanical timer |

Technical Data

GENERAL	
Outer dimensions (height/width/depth)	850 mm/900 mm/600 mm
Voltage/frequency	230 V ~ 50 Hz
Fuse protection	min. 10 A
Cable type / cross section	H05VV-FG 3 x 0,75 mm ²
Cable length	max. 2 m
Gas type/pressure	LPG G 30/28-30 mbar
Total gas consumption	15.5 kW
Conversion to gas type/pressure [§] – optional	NG G 20/20 mbar
HOB	
Burners	
Rear left	Normal burner
Power	2000 W
Front left	Normal burner
Power	2000 W
Middle	Wok burner
Power	3600 W
Rear right	Rapid burner
Power	2900 W
Front right	Auxiliary burner
Power	1000 W
OVEN/GRILL	
Main oven	Gas oven
Inside illumination	15–25 W
Grill power consumption	4.0 kW

Accessories supplied with the unit

- i** Accessories supplied can vary depending on the product model. All the accessories described in the user manual may not exist on your product.

Heat shield

For grilling with the oven door open. Protects the control panel and knobs against heat and soiling.

- Insert the heat shield into the pins below the control panel.

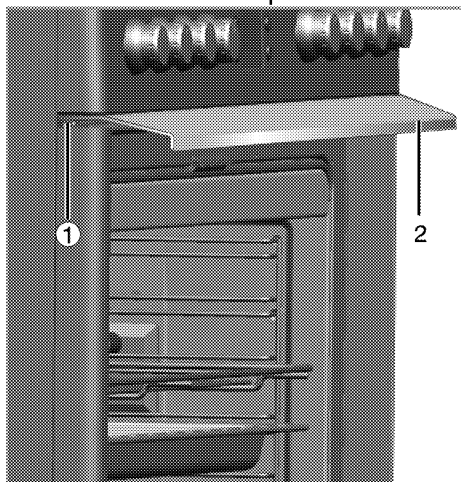

- 1 Pin
2 Knob protection sheet

Injector table

Position hob zone	2000 W Rear left	2000 W Front left	3600 W Middle	2900 W Rear right	1000 W Front right
Gas type / Gas pressure					
G 20/20 mbar	103	103	147	115	72
G 30/28-30 mbar	72	72	96	87	50
Gas type / Gas pressure	Gas oven		Grill		
G 20/20 mbar	142		142		
G 30/28-30 mbar	97		97		

Turn spit function

Can be used for grilling meat, poultry and fish from all sides.

- Fix the food to be grilled to the turn spit with the forks.
- Insert the turn spit into the drive placed on the left side of the cavity and hang up into the turn spit hook placed on the right side of the cavity.

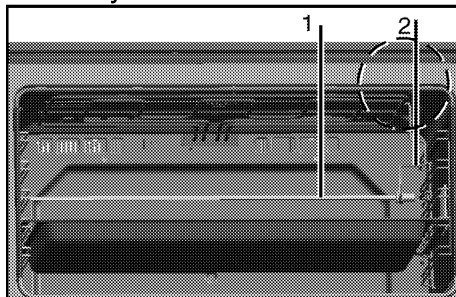

- 1 Spit
2 Spit hook

2 Safety Instructions

Explanation of safety instructions

The following types of safety instructions and information are used in this manual. They can be distinguished by the symbol and the initial signal word.



DANGER

High risk of personal injury.

Non-observance may or will cause serious injuries or death.



CAUTION

Risk of personal injury.

Non-observance may or will cause minor or medium injuries.



NOTICE

Risk of material damage.

Non-observance may or will cause damage on the appliance or other objects.



Important

Tip for the user.

Useful information on how to use the appliance. No injury risk information.

Basic safety instructions

- The manufacturer reserves its right to make changes in the technical specifications in order to improve the appliance quality without any prior notice. Figures included in this manual are for schematic purpose only and may not match

exactly with your appliance. Values stated on the markings of the appliance or in other printed documents supplied with the appliance are obtained under laboratory conditions as per relevant standards. These values may vary according to the usage of the appliance and ambient conditions.

- This appliance is not intended for use by persons (including children) with reduced physical, sensory or mental capabilities, or lack of experience and knowledge, unless they have been given supervision or instruction concerning use of appliance by a person responsible for their safety.

Children should be supervised to ensure that they do not play with the appliance.

- "An additional protective means to avoid contact with the oven door is available. This part should be fitted when young children are likely to be present."
- Never use when judgement or coordination is impaired by the use of alcohol and/or drugs.
- Do not operate the appliance if it is defective or shows any visible damage.
- Do not carry out any repairs or modifications on the appliance. However, you may remedy some malfunctions; see *Troubleshooting*, page 32.
- Be careful when using alcoholic drinks in your dishes. Alcohol

evaporates in high temperatures and may cause fire since it will catch fire when it gets in contact with hot surfaces.

- Do not heat closed food containers and glass jars. Pressure that may build-up in the jar can cause it to burst.
- Ensure that no flammable materials are adjacent to the appliance as the sides become hot during use.
- Do not leave empty pots or pans on plates that are switched on. They might get damaged.
- Since it may be hot, do not leave plastic or aluminum dishes on the surface of appliance. These kind of dishes should not be used to keep food either.
- Do not place baking trays, dishes or aluminium foil directly onto the bottom of the oven. The heat accumulation might damage the bottom of the oven. Keep all ventilation slots clear of obstructions.
- Appliance may be hot when it is in use. Never touch the hot burners, inner sections of the oven, heating elements etc. Keep children away!
- Always use heat-resistant gloves when putting or removing the dishes into/from your oven.
- Don't use the cooker with front door glass removed.
- Rear surface of the oven gets hot when it is in use. Gas / Electric connection should not touch the rear surface, otherwise the mains cable may get damaged. Do not trap the mains cable between the

hot oven door and frame. Do not route the mains cable over the hot cooking section. Otherwise, cable insulation may melt and cause fire as a result of short circuit.

- Check all controls on the appliance are switched off after use.



Important

For the warranty to be valid, the appliance must be installed by a qualified person in accordance with current regulations.

Safety for children

- Accessible parts of the appliance will become hot whilst the appliance is in use and until the appliance has cooled, children should be kept away.
- Accessible parts may be hot when the grill is in use. Young children should be kept away.
- Do not store any items above the appliance that children may reach.
- The packaging materials will be dangerous for children. Keep the packaging materials away from children. Please dispose of all parts of the packaging according to environmental standards.
- When the door is open, do **not** load any heavy object on it and do **not** allow children to sit on it. It may overturn or door hinges may get damaged.

Safety when working with gas

- Any works on gas equipment and systems may only be carried out

by authorised qualified persons who are Gas Safe registered.

- "Prior to the installation, ensure that the local distribution conditions (nature of the gas and gas pressure) and the adjustment of the appliance are compatible."
- "This appliance is not connected to a combustion products evacuation device. It shall be installed and connected in accordance with current installation regulations. Particular attention shall be given to the relevant requirements regarding ventilation;" See *Before installation, page 11*
- "The use of gas cooking appliance results in the production of heat and moisture in the room in which it is installed. Ensure that the kitchen is well ventilated: keep natural ventilation holes open or install a mechanical ventilation device (mechanical extractor hood). Prolonged intensive use of the appliance may call for additional ventilation, for example increasing the level of the mechanical ventilation where present."
- Gas appliances and systems must be regularly checked for proper functioning. Please arrange for annual maintenance.
- Clean the gas burners regularly. The flames should be blue and burn evenly.
- Good combustion is required in gas appliances. In case of incomplete combustion, carbon monoxide (CO) might develop. Carbon monoxide is a colourless,

odourless and very toxic gas, which has lethal effect even in very small doses.

- Request information about gas emergency telephone numbers and safety measures in case of gas smell from you local gas provider.

What to do when you smell gas



DANGER

Risk of explosion and poisoning!

Do not use open fire and do not smoke.

Do not operate any electric switches (e.g. light switch or door bell).

Do not use a telephone or mobile phone.

1. Close all valves on gas appliances and gas meter.
2. Open doors and windows.
3. Check all tubes and connections for tightness. If you still smell gas leave the property.
4. Warn the neighbours.
5. Call the fire-brigade. Use a telephone outside the house.
6. Do not re-enter the property until you are told it is safe to do so.

Safety when working with electricity

- Any work on electric equipment and systems may only be carried out by authorized qualified persons.
- In case of any damage, switch off the appliance and disconnect it from the mains supply by

removing the fuse or switching off the circuit breaker.

- Ensure that the fuse rating is correct.

Intended use

The appliance is designed for domestic use only. Commercial use is not admissible.

This appliance should not be used for warming the plates under the grill, hanging towels and dish cloths etc. on the handles, drying and the heating purposes.

This product should not be used for heating purposes.

The manufacturer shall not be liable for any damage caused by improper use or handling errors.

The appliance can be used for defrosting, baking, roasting and grilling food.

Disposal

Packaging material



DANGER

Risk of suffocation by the packaging materials!

Keep children away from the packaging materials.

The packaging material and transport locks are made from materials that are not harmful to the environment. Please dispose of all parts of the packaging according to environmental standards. This is beneficial to the environment.

Old equipment



This appliance bears the selective sorting symbol for waste electrical and

electronic equipment (WEEE). This means that this appliance must be handled pursuant to European Directive 2002/96/EC in order to be recycled or dismantled to minimize its impact on the environment. For further information, please contact your local or regional authorities.

Electronic appliances not included in the selective sorting process are potentially dangerous for the environment and human health due to the presence of hazardous substances.

Future transportation



NOTICE

Do not place other items on the top of the appliance. The appliance must be transported upright.

Store the appliance's original box and transport the appliance in its original carton. Follow the guidance marks that are printed on the carton.



Important

Verify the general appearance of your equipment by identifying possible damage during the transportation.

Secure the caps and pan supports with adhesive tape.

To prevent the wire shelf and tray inside the oven from damaging the oven door, place a strip of cardboard onto the inside of the oven door that lines up with the position of the trays. Tape the oven door to the side walls.

If you do not have the original carton

Pack the appliance in bubble wrap or thick cardboard and tape it securely in order to prevent damage during transportation.

3 Installation

Before installation

Please note the product is packed without the feet fitted, therefore please ensure the feet are fitted as per the instructions; see *Installation and connection*, page 13 before the appliance is placed in its final position. To ensure that critical air gaps are maintained under the appliance, we recommend that this appliance is mounted on a solid base and that the feet do not sink into any carpet or soft flooring.

The kitchen floor must be able to carry the weight of the appliance plus the additional weight of cookware and bakeware and food;

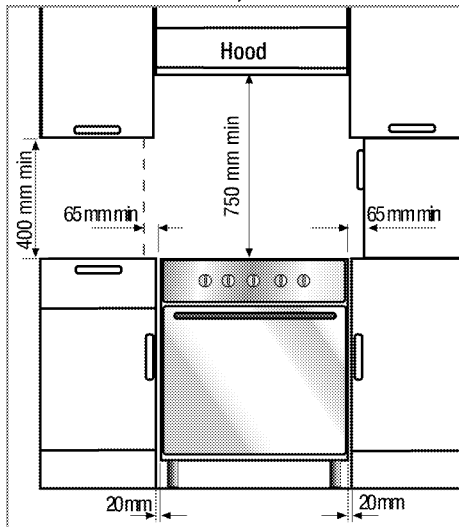

A safety distance must be left between the appliance and the kitchen walls and furniture. See figure (values in mm).

- It can be used with cabinets on either side but in order to have a minimum distance of 400mm above hotplate level allow a side

clearance of 65mm between the appliance and any wall, partition or tall cupboard.

- It can also be used in a free standing position. Allow a minimum distance of 750mm from the hob surface to adjacent surfaces above the hob surface and 600mm to a cabinet above.
- If a appliance hood is to be fitted, refer to the manufacturer's instructions regarding fixing height.
- Movement of your appliance is most easily achieved by lifting the front as indicated in the drawing. Open the oven door sufficiently to allow a comfortable and safe grip on the underside of the oven roof avoid causing any damage to the grill element or any internal parts of the oven. Do not move by pulling on the door handle or knobs. Move the appliance a bit at a time until placed in the position required.

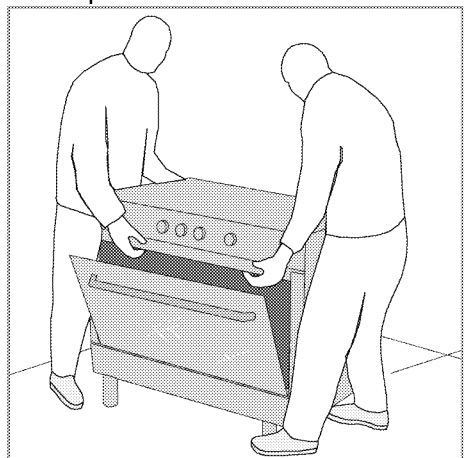

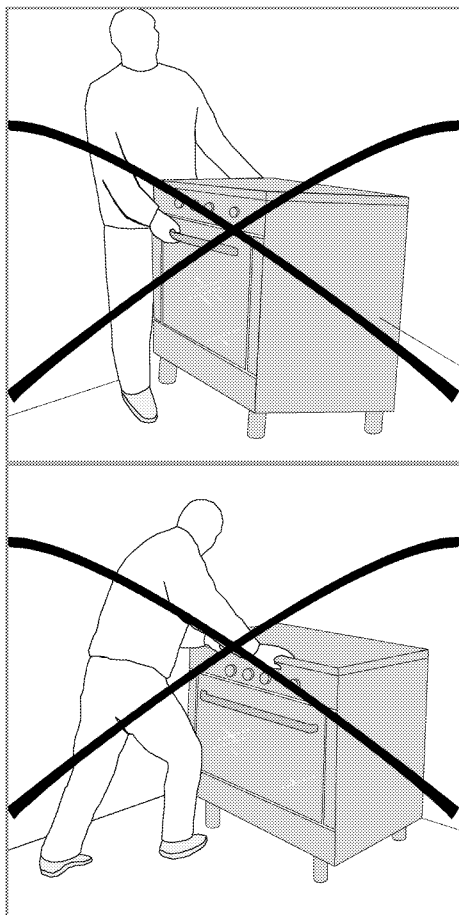

Important

The appliance must be secured against overbalancing by using the supplied two safety chains on your oven. Fasten hook (1) to the kitchen wall (5) and connect safety chain (2) to the hook.

Room ventilation

The air for combustion is taken from the room air and the exhaust gases are emitted directly into the room.

Good room ventilation is essential for safe operation of your appliance. If there is no window or door available for room ventilation, an extra ventilation must be installed.

Do not install this appliance in a room below ground level unless it is open to ground level on at least one side.

Failure to install correctly is dangerous and could result in prosecution.

Prolonged intensive use of the appliance may call for additional ventilation, for example the opening of a window, or the use of permanent fixed mechanical ventilation system, for example, an extractor fan or cooker hood that ventilates to the outside.

- The appliance corresponds to device class 1, i.e. it may be placed with the rear and **one** side to kitchen walls, kitchen furniture or equipment of any size. The kitchen furniture or equipment on the **other** side may only be of the same size or smaller.
- Any kitchen furniture next to the appliance must be heat-resistant (100 °C min.).

Room size	Ventilation opening
smaller than 5 m ³	min. 100 cm ²
5 m ³ to 10 m ³	min. 50 cm ²
greater than 10 m ³	not required
In the cellar or basement	min. 65 cm ²

Installation and connection



Important

Do not install the appliance next to refrigerators or freezers. The heat emitted by the appliance will lead to an increased energy consumption of cooling appliances.

- For installation the appliance must be connected in accordance with all local gas and/or electrical regulations.
- Carry the appliance with at least two persons.



NOTICE

Material damage!

The door and/or handle must not be used for lifting or moving the appliance.

- The appliance must be placed directly on the floor. It must not be placed onto a base or a pedestal.

Connection to the gas supply



DANGER

Risk of explosion or poisoning by unprofessional installation.

The appliance may be connected to the gas distribution system only by an authorized qualified person who is Gas Safe registered.



DANGER

Risk of explosion!

Before starting any work on the gas installation, please shut off the gas supply.

- "The adjustment conditions for this appliance are stated on the label (or data plate)."



NOTICE

Your appliance is adjusted for LP gas.

Connecting the gas hose

- If necessary, interchange the sharp hose at the rear of your oven tip with the plug by selecting a suitable place on basis of the location of the gas bottle.

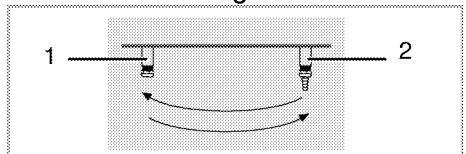

1 Plug

2 Hose nozzle

- Have your appliance connected in a way that it will be close to the gas connection and avoid gas leakage.
- Plastic hose to be used must not be longer than 125 cm.
- Install the clamp to the hose. Soak one end of the hose (15 mm inner diameter) into boiling water for one minute to soften it.
- Then, slip the softened end of the hose completely onto the sharp hose end of your appliance. Finally, tighten the clamp completely by a screwdriver.
- Repeat the same procedure for the other end of the hose and complete the gas bottle connection.

- Never forget to make the gas leakage control.



DANGER

Risk of explosion and suffocation!

LPG bottles must not be stored in the house.

- If you need to use your appliance later with a different type of gas, you must consult the authorised service for the related conversion procedure.

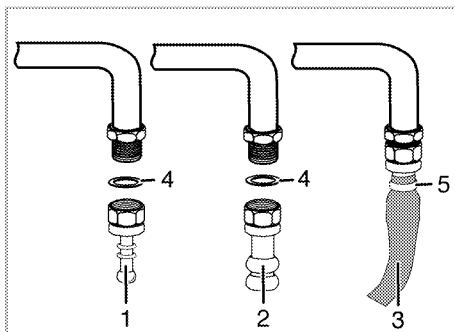
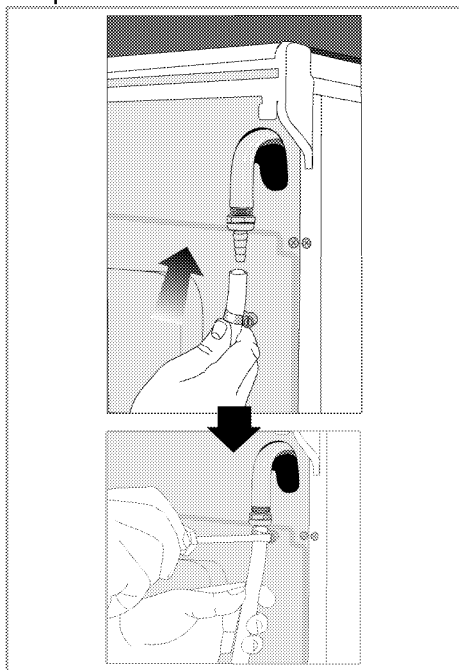

- 1 Hose nozzle-LPG
- 2 Hose nozzle-NG
- 3 Safety hose
- 4 O-ring (seal)
- 5 Clamp

Leakage control at the connection part

- Make sure that all knobs on the appliance are turned off. Make sure that the gas supply is open. Prepare soapy foam and apply it onto the connection edge of the hose for gas leakage control.
- Soapy part will froth if there is a gas leakage. In this case, inspect the gas connection once again.



Important

Never use a match or lighter to make the gas leakage control.



DANGER

Risk of explosion by damage of the safety tube!

The safety tube must not be clamped, bent or trapped or come into contact with hot parts of the appliance.

Connection to the mains supply



Important

This appliance must be earthed!

Our company shall not held responsible for any damage caused by using the appliance without earthed socket.



DANGER

Risk of electric shock, short circuit or fire by unprofessional installation!

The appliance may be connected to the mains supply only by an authorized qualified person and the appliance is only guaranteed after correct installation.



DANGER

Risk of electric shock, short circuit or fire by damage of the mains lead!

The mains lead must not be clamped, bent or trapped or come into contact with hot parts of the appliance.

If the mains lead is damaged, it must be replaced by a qualified electrician.

The mains supply data must correspond to the data specified on the rating plate of the appliance. The rating plate is either seen when the door or the lower cover is opened or it is located at the rear wall of the appliance depending on the appliance type.

The mains supply data must correspond to the data specified on the rating plate of the appliance. The rating plate is located at the rear housing of the appliance.

The supply cable of the appliance must correspond to the specifications; see technical data table *Technical Data*, page 5.



Important

The plug should be easily accessible after installation (but not above the hob).

Plug the mains lead into the socket.



DANGER

Risk of electric shock!

Before starting any work on the electrical installation, please disconnect the appliance from the mains supply.

- Position appliance up to the kitchen wall.
- Securely attach safety chain to the wall behind the cooker.
- To align the appliance with the worktop, adjust the feet turning right or left hand as required.
- **Installation of the oven feet**
Four feet are supplied with the appliance.
Each foot should be mounted to the housings placed on all corners of the bottom.

The appliance must be lifted to a sufficient height in order to allow easy fitting of the feet. A minimum of two people is recommended for this operation. If you are resting the product on something please ensure that there is adequate support across all of the base of the appliance.

Place the screwed side of the foot to the housing and screw clockwise direction.

For your safety, adjust the feet so that the cooker is level (use a spirit

level to check) There is a risk of burning, pots and pans spilling or falling off and poor cooking performance if the cooker is not level.

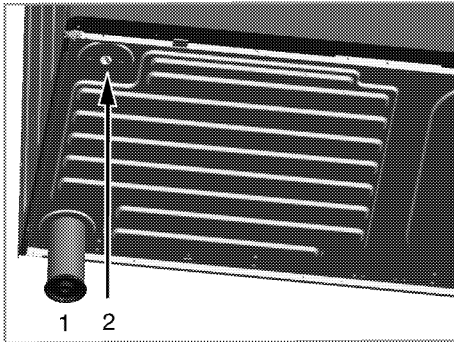

- 1 Foot
- 2 Foot housing

Final check

1. Check electrical functions.
2. Turn on gas supply.
3. Check gas installations for secure fitting and tightness.
4. Ignite burners and check appearance of the flame.

Important

The flames should be blue and burn smoothly. If the flames appear yellowish, check secure position of the burner cap or clean the burner. Switch off gas and let burner cool before touching it.

Gas conversion



DANGER

Risk of explosion!

Before starting any work on the gas installation, please shut off the gas supply.

In order to change your appliance's gas type, change all injectors and make flame adjustment for all valves at reduced flow rate position.

Exchange injector for the burners

1. Take off burner cap and burner body.
2. Unscrew injectors.
3. Fit new injectors.
4. Check all connections for secure fitting and tightness.



NOTICE

New injectors have their position marked on their packing or injector table on *Injector Table, page 6* can be referred to.

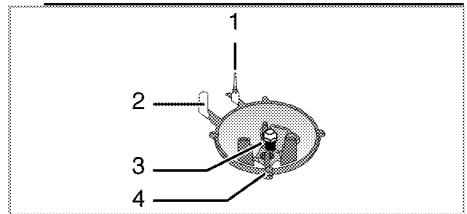

- 1 Flame failure device (model dependant)
- 2 Sparking plug
- 3 Injector
- 4 Burner



Important

Unless there is an abnormal condition, do not attempt to remove the gas burner taps. You must call an Authorised service agent if it is necessary to change the taps.

Reduced gas flow rate setting for hob taps

1. Ignite the burner that is to be adjusted and turn the knob to the reduced position.
2. Remove the knob from the gas tap.
3. Use an appropriately sized screwdriver to adjust the flow rate adjustment screw.

For LPG (Butane - Propane) turn the screw clockwise.

For the natural gas, you should turn the screw **counter-clockwise** once.
 » The normal length of a straight flame in the reduced position should be 6-7 mm.

4. If the flame is higher than the desired position, turn the screw clockwise. If it is smaller turn anticlockwise.
5. For the last control, bring the burner both to high-flame and reduced positions and check whether the flame is on or off.

Depending on the type of gas tap used in your appliance the adjustment screw position may vary.

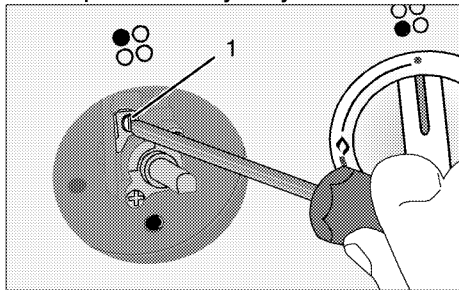

1 Flow rate adjustment screw

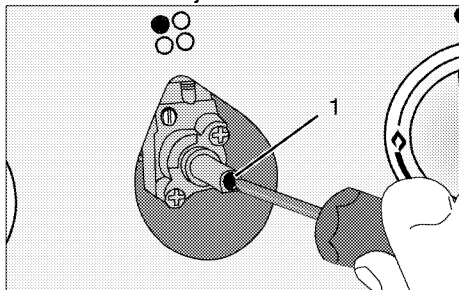

1 Flow rate adjustment screw

Exchange injector for the grill

1. Open the door.
2. Unscrew the two screws of grill burner.
3. Take out the grill burner.
4. Remove the grill injector from injector holder.

5. Fit new injector.

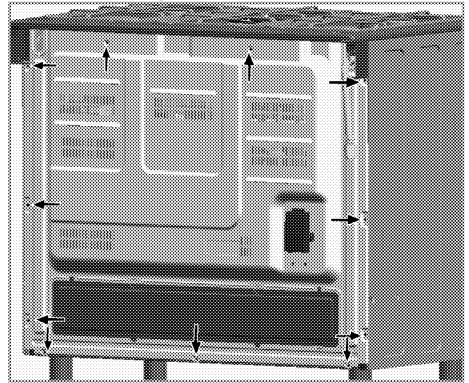

1 Screw
2 Grill burner

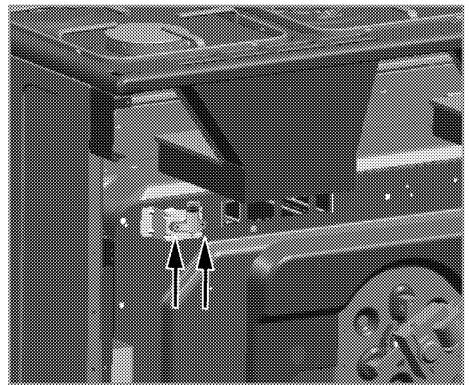

1 Injector and Injector holder

Exchange injector for the oven

1. Unscrew fastening two screws of the rear cover.
2. Unscrew the two screws from the injector holder.
3. Pull out the injector holder.
4. Remove the injector.
5. Fit new injector.

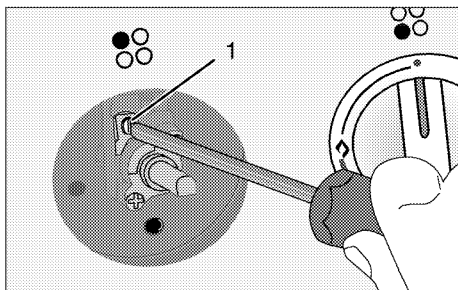
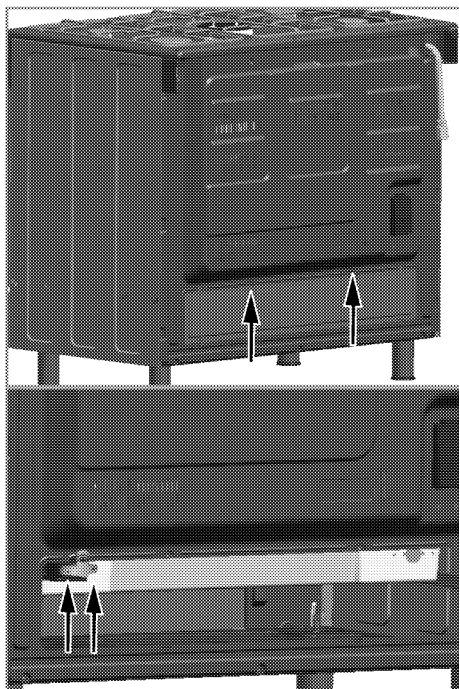

5. Set the flame length to 2 to 3 mm by means of the screw 1 on the oven tap. Turning the screw in clockwise direction reduces the flame, turning it anticlockwise increases the flame.



Important

If the temperature of the oven increases unattendedly, turn off the oven and call the authorised service to have oven thermostat repaired.

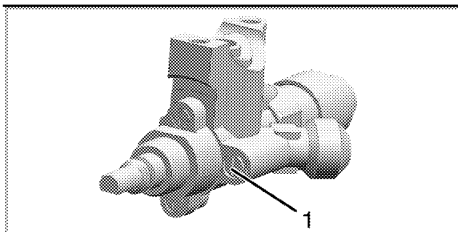

Butan/propan	Natural gas
Fasten the screw until the end	Loosen the screw 1/2 round
	

Reduced flow adjustment for the gas oven

For the appropriate functioning of the oven re-checking the by-pass adjustment is extremely important. In order to provide maximum security to the user these operations have to be done with care.

1. Ignite the burner that is to be adjusted and turn the knob to the high flame position.
2. Close the oven door and wait for 10 to 15 minutes until the oven becomes ready for adjustment.
3. Take out the knob
4. After 15 minutes, adjust the oven to the lowest flame position.



NOTICE

If the gas type of the unit is changed, then the rating plate that shows the gas type of the unit must also be changed.

4 Preparation

Tips for saving energy

The following tips will help you to use your appliance in an ecological way and to save energy:

- Use dark coloured and enamel coated trays, since the heat transmission will be better.
- While cooking your meals, perform a preheating operation if it is advised in the user manual or cooking instructions.
- During cooking, do not open the oven door frequently.
- Try to cook more than one type of meal within the oven at the same time (You can cook two different meals at the same time by locating cooking bowls on the same shelf). It will be suitable to cook more than one meal after each other. The oven will already be hot.
- Defrost frozen meals before cooking them.
- Use pots/pans with lids for cooking. Without a lid, the energy consumption may be up to four times higher.
- Choose the burner/plate which is suitable to the saucepan base. Always choose the correct size of saucepans for your meals. For larger burners/plates more energy is needed.

Initial operation

First cleaning of the appliance



NOTICE

The surface might get damaged by some detergents or cleaning materials.

Do not use aggressive detergents, cleaning powder/cream or any sharp objects.

1. Remove all packaging materials.
2. Wipe the surfaces of the appliance with a damp cloth or sponge and dry with a cloth.

Initial heating



WARNING

Hot surfaces may cause burns!

Do not touch the hot surfaces of the appliance. Use oven gloves. Keep children away from the appliance.



Important

Smell and smoke may emit during first heating. Ensure that the room is well ventilated.

Any production residues or conservation layers must be burnt off before the first use. Heat up the appliance for about 30 minutes and then switch it off.

Gas oven

1. Take all baking trays and wire shelf from the oven.
2. Close oven door.

3. Select largest flame of the gas oven; see *How to use the gas oven, page 24*.
4. Heat approximately 30 minutes.
5. Switch off oven; see *How to use the gas oven, page 24*
2. Close oven door.
3. Select largest flame of the grill oven; see *How to operate the gas grill, page 26*.
4. Heat approximately 30 minutes.
5. Switch off grill; see *How to operate the gas grill, page 26*

Grill oven

1. Take all baking trays and wire shelf from the oven.

5 How to use the hob

General information on cooking



DANGER

Risk of fire by overheated oil!

When you heat oil, do not leave it unattended.

Never try to extinguish the fire with water! When oil has caught fire, immediately cover the pot or pan with a lid. Switch off the hob if safe to do so and phone the fire service.

- Ensure handles of pans cannot accidentally be caught or knocked and do not get hot by adjacent heating zones. Avoid pans that are unstable and easily tipped. Pans that are too heavy to move easily when filled can also be a hazard. Only use flat bottomed pots or pans.
- Use pans which have sufficient capacity for the amount of food being cooked so they don't boil over and cause unnecessary cleaning. Do not place lids on the burners. Always position pans centrally over the burners. When transferring pans from one burner to another always lift the pans do not slide them.

Cooking with gas

- The size of the pan and the size of the gas flame should match each other. Adjust the gas flames so that they do not go beyond the bottom of the pan always place

the pan onto the pan support in a central position.

How to use hobs

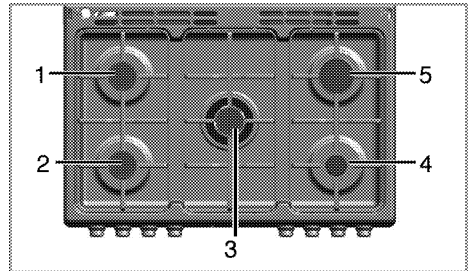

- 1 Normal burner 20-22 cm
- 2 Normal burner 20-22 cm
- 3 Wok burner 22-24 cm
- 4 Auxiliary burner 12-18 cm
- 5 Rapid burner 22-24 cm is list of advised diameter of pots to be used on related burners.

The large flame symbol corresponds to the highest cooking power, the small flame symbol corresponds to the lowest cooking power. In the off position (top) the gas supply to the burner is turned off.

Ignite the gas burners



The gas burners are ignited by means of the ignition button.

1. Keep hob control knob pressed.
2. Turn anticlockwise to the large flame symbol.
3. Press ignition button and release it again. Repeat the process until the emanating gas is lit.

4. Adjust to the desired cooking power.

Switch off the gas burners

Turn burner control knob to off position (top).

Flame failure device (model dependant)

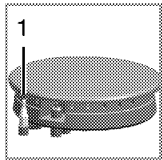

In case of any flame failures for any reasons in the top burners, the flame failure device immediately cuts of the gas flow.

1 . Flame failure device

- Turn the knob clockwise direction by pressing and wait for its ignition.
- Keep the knob at pressed position for 3-5 seconds after you see the flame around the burner.
- Repeat the sequence of operations if the flame does not continues. After you release the knob, if the ignition does not continue repeat

the same process by keeping the knob pressed for 15 seconds.



DANGER

Risk of deflagration incase of unburned gas!

Do not press the knob for longer than 15 seconds if there was no ignition.

Wait for one minute and then repeat the ignition process.

Wok burner

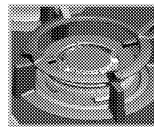

The wok burner is used for rapid cooking, in particular for cooking of sliced vegetables and meat in a very quick time period.

A wok frying pan is a wide and shallow pan which conducts heat rapidly allowing cooking of vegetables and meat evenly at the same temperature, ensuring that their original nourishment value is maintained.

6 How to Operate the Oven

General information on baking, roasting and grilling



DANGER

Risk of scalding by hot steam!

Take care when opening the oven door as steam may escape.

Tips for baking

- Use non-stick coated appropriate metal plates or aluminum containers or heat-resistant silicone moulds.
- Make best use of the space on the rack.
- It is recommended to place the baking mould in the middle of the rack.
- Select the correct shelf position before turning the oven or grill on - don't move oven shelves when hot.
- Keep the oven door closed..

Tips for roasting

- Seasoning with lemon juice and black pepper will improve the cooking performance when cooking a whole chicken, turkey or a large piece of meat.
- Meat with bones takes about 15 to 30 minutes longer before it is cooked than a roast of the same size without bones.
- You should calculate about 4 to 5 minutes cooking time per centimeter height of the meat.
- Let meat rest in the oven for about 10 minutes after the cooking time. The juice is better distributed all

over the roast and does not run out when the meat is cut.

- Fish in a fire-resistant dish should be placed on the rack at the medium or lower level.

Tips for grilling

Grilling is ideal for cooking meat, fish and poultry and will achieve a nice brown surface without it drying out too much. Flat pieces, meat skewers and sausages are particularly suited for grilling as are vegetables with a high water content such as tomatoes and onions.

- Distribute the pieces to be grilled on the wire shelf.
- If the grilling is on the wire shelf, locate a dripping pan under it in order to collect the fat.
- Add some water in dripping pan for easy cleaning.

Insert the heat shield

For grilling with the oven door open. Protects the control panel and knobs against heat and soiling.

1. Insert the heat shield into the pins below the control panel.

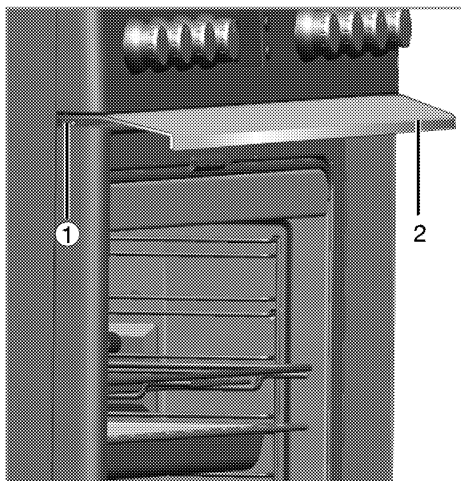

- 1 Pin
- 2 Knob protection sheet

» When the heat shield is inserted, the oven door remains open.

How to use the gas oven



Important

The appliance has a safety valve. When the flame goes out, the gas supply is automatically interrupted. So an accumulation of unburnt gas is prevented.

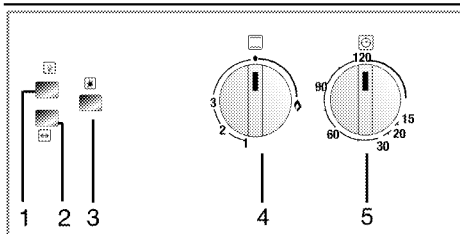

- 1 Lamp button
- 2 Turnspit button
- 3 Ignition button
- 4 Oven knob
- 5 Mechanical timer

The gas oven is operated by the gas oven control knob. In off position (top) the gas supply is locked.

Switch on the gas oven

The gas oven is ignited with the ignition button.

1. Open oven door.
2. **Keep** gas oven control knob **pressed** and turn it counterclockwise.
3. Press ignition button and release it again.
 - » Repeat the process until the emanating gas is ignited.
4. Keep the gas oven control knob pressed for another 3 to 5 seconds.
5. Be sure that gas has ignited and flame is present.
6. If there is no electricity; ignite the gas with the gas lighter from the ignition control hole.
7. Select the desired baking power.

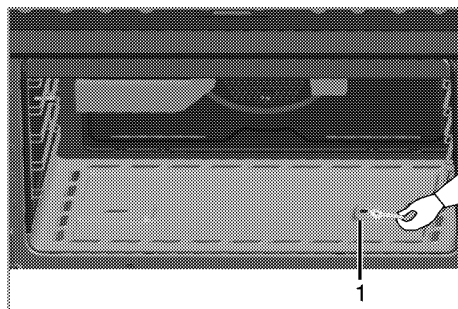

- 1 Ignition control hole



DANGER

Risk of deflagration by gas that is not ignited!

"The device shall not be operated for more than 15 s. If after 15 s the burner has not lit, stop operating the device and open the compartment door and/or wait at least 1 min before attempting a further ignition of the burner."

Switch off the gas oven

1. Turn gas oven control knob to off position (top).

The gas levels mean:

Gas level	1	2	3
Temperature	170 °C	280 °C	284 °C

Baking and roasting

Food	Preheating *	Insertion level	Control knob position	Cooking time
Apple pie	10 min.	4...5	1	25...30 min.
Fruit tart	10 min.	4...5	1	25...35 min.
Pie	10 min.	3...4	1	30...40 min.
Cookies	10 min.	4...5	1	25...35 min.
Pastry	10 min.	4	1	35...45 min.
Cake	10 min.	4	1	30...40 min.
Biscuits	–	4...5	1	20...30 min.
Roast lamb	10 min.	3	1	35...45 min. per 450 g + 30 min.
Roast Beef	10 min.	2...3	1	50...60 min. per 450 g + 30 min.
Turkey	10 min.	3	1	50...60 min. per 450 g + 30 min.
Poultry	10 min.	3	1	30...40 min. per 450 g + 25 min.
Casseroles	–	3	1	90...120 min. [§]
Fish	10 min.	3	1	35...45 min.
Macaroni	10 min.	4	1	40...45 min.
Small cakes	10 min.	4	1	20...30 min.
Victoria sandwich	10 min.	4	1	22...28 min.

* at control knob position 2 / [§] depending on quantity / [#] depending on size

Cooking times table



Important

The values indicated in the table below are data indicative. They may vary according to the type of food as well as your preferences of cooking.



Important

Level 1 is the **bottom** level in the oven.



NOTICE

Maximum load for the oven tray:
4 kg (8,8 lbs).

How to operate the gas grill



Important

The appliance has a safety valve. When the flame goes out, the gas supply is automatically interrupted. So an accumulation of unburnt gas is prevented.

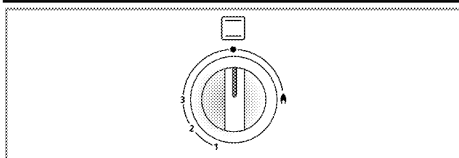

The grill is operated by the grill control knob. In off position (top) the gas supply is locked.

If you want to make grill with OPENED door; you must use heat (Knob protection) shield see *General information on baking, roasting and grilling, page 23*.

If you do not use "heat shield", during grill operation the oven door must be CLOSED.

Switch on grill

The gas grill is ignited with the ignition button.

1. Open oven door.
2. Keep grill control knob **pressed** and turn it in **clockwise** onto the grill symbol.
3. Press ignition button and release it again.
» Repeat the process until the gas is ignited.
4. Keep the grill control knob pressed again 3-5 seconds.
5. Be sure that ignited and flame occurred.

6. If there is no electricity; ignite the gas with the gas lighter direct to grill burner.

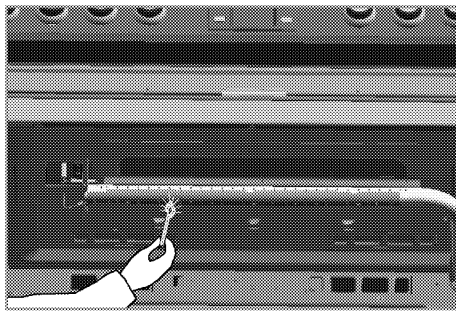

DANGER

Risk of deflagration by gas that is not ignited!

"The device shall not be operated for more than 15 s. If after 15 s the burner has not lit, stop operating the device and open the compartment door and/or wait at least 1 min before attempting a further ignition of the burner."

Switch off grill

1. Turn grill control knob to off position (top).

Turn spit function

Can be used for grilling meat, poultry and fish from all sides.

After operating the oven in grill position, press turnspit button.

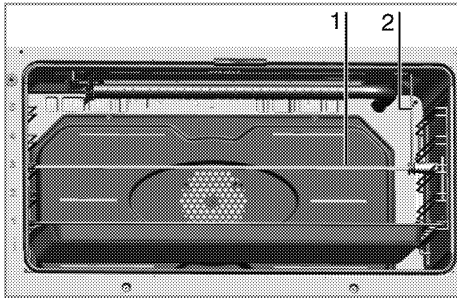

- 1 Turnspit
- 2 Spit hook

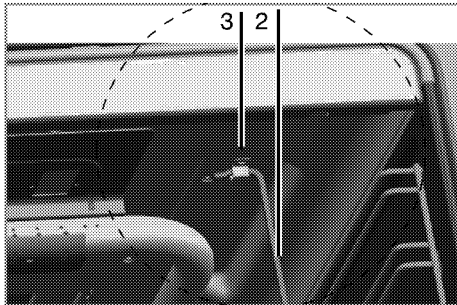

- 3 Spit hook bracket
- Fix the food to be grilled to the turn spit with the forks.
- Insert the turn spit into the drive placed on the left side of the cavity and hang up into the turn spit hook placed on the right side of the cavity.
Please be sure that spit hook must be inserted to hook bracket.
- Locate a tray one of the bottom shelves in order to collect to oils and for easy cleaning put some water in it.

- **Do not forget to remove plastic part from spit.**
- After grilling, screw the plastic handle to the skewer and take out the food from oven.



NOTICE

Use maximum 5 kg load, i.e. chicken or turkey with turnspit.

Cooking times table



Important

The values indicated in the table below are data indicative. They may vary according to the type of food as well as your preferences of cooking.



Important

Level 1 is the **bottom** level in the oven.



NOTICE

Do not use the upper level for grilling.

Food	Shelf position	Cooking time	Knob position
<u>Lamb chop</u>	<u>4...5</u>	<u>15-20</u>	<u>3</u>
<u>Roast beef</u>	<u>4...5</u>	<u>15-20</u>	<u>3</u>
<u>Veal chop</u>	<u>4...5</u>	<u>15-20</u>	<u>3</u>
<u>Mutton chop</u>	<u>4...5</u>	<u>15-20</u>	<u>3</u>
* Depend on the thickness			

How to use the alarm clock

As soon as the defined period of time has expired, the alarm clock will emit a signal. The alarm clock has no influence on the functions of the oven.

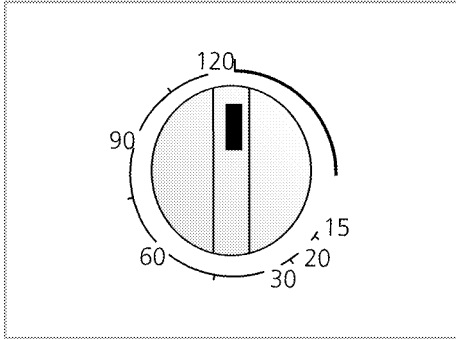

Setting the alarm clock

1. Set the period of time which is to elapse before the alarm signal

sounds by turning the timer knob clockwise.

2. As soon as the cooking period is completed, the alarm rings and the timer knob turns counterclockwise automatically. The alarm clock does not switch the oven off.

Important

To switch the oven off, the function knobs should be turned counterclockwise to the close position.

7 Maintenance and Care

General information



DANGER

Risk of electric shock!

Switch off the electricity before cleaning appliance to avoid an electric shock.



DANGER

Hot surfaces may cause burns!

Allow the appliance to cool down before you clean it.



NOTICE

The surface might get damaged by some detergents or cleaning materials.

Do not use aggressive detergents, cleaning powder/cream or any sharp objects.

Clean the appliance thoroughly after each use; in this way it will be possible to remove cooking residues more easily, thus avoiding these from burning the next time the appliance is used.

No special cleaning agents are required for cleaning the appliance. It is recommended to use warm water with washing liquid, a soft cloth or sponge and use a dry cloth for drying.

Do not use any abrasive cleaning materials!

(model dependant) - Do not use any harsh abrasive cleaners, or hard metal scrapers to clean the glass lid as they may scratch the surface. This may destroy the glass.



Important

Do not use steam cleaners for cleaning.

How to clean the hob

Gas hobs

1. Remove pan supports and burner caps and clean them.
2. Clean the hob.
3. Refit burner caps and check that they are securely positioned.
4. While placing pan supports, take care that burners centered to pan supports.

Cleaning the control panel



NOTICE

Damage of the control panel!
Do not remove the control knobs for control panel cleaning.

Clean control panel and control knobs.

Cleaning the oven

No oven cleaner or any other special cleaning agent is required for cleaning the oven. It is recommended to wipe the oven with a damp cloth while it is still warm.

To clean the side wall,

1. Remove the front section of the side rack by pulling it in the opposite direction of the side wall.
2. Remove the side rack completely by pulling it towards you.

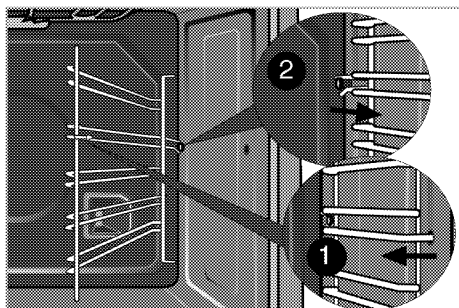

Clean oven door

Don't use any harsh abrasive cleaners or sharp metal scrapers for cleaning the oven door. They could scratch the surface and destroy the glass.

Removal of oven door

1. Open the front door.
2. Open the clips at the hinge housing on the right and left hand sides of the front door by pressing them down as illustrated in the figure.

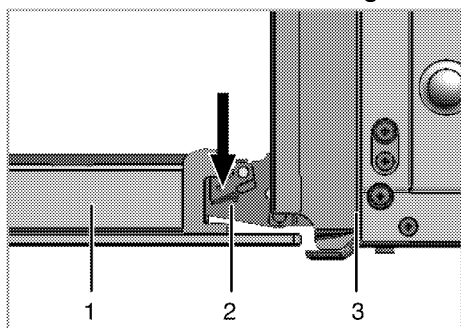

- 1 Front door
- 2 Hinge
- 3 Oven

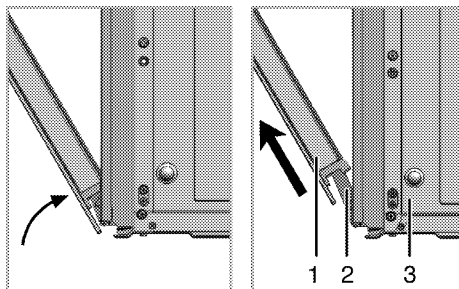

3. Move the front door to half-way.
4. Remove the front door by pulling it upwards to release it from the right and left hinges.



NOTICE

Steps carried out during removing process should be performed in reverse order (steps 4, 3, 2 and 1) to reattach the door. Do not forget to close the clips at the hinge housing when reinstalling the door.

Taking off the door inner glass

The inner glass panel of the oven door can be removed for cleaning.

1. Open oven door.
 - Remove metal part (1) by unscrewing three screws that hold the metal part.
 - Remove plastic holders (3) on left and right hand side by pulling towards yourself.

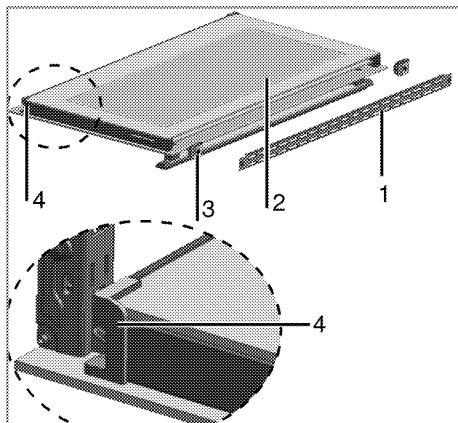

Replacing the oven lamp



DANGER

Hot surfaces may cause burns!

Make sure that the appliance is switched off and cooled down in order to avoid the risk of an electrical shock.

The oven lamp is a special heat-resisting (T 300 °C) electric light bulb; see *Technical Data*, page 5. Oven lamps can be obtained from a good local electrical store.



NOTICE

Position of lamp might vary from diagram.

- 1 Metal part
- 2 Inner glass
- 3 Plastic holder
- 4 Plastic housing

- Take off the inner glass, by pulling towards yourself until inner glass (2) free of plastic housing (4).
- To reassemble the inner glass; take care, place the glass to plastic housing and ensure that the inner glass is positioned correctly in the plastic housing.

1. Switch off the appliance at the mains.
2. Unscrew glass cover by turning anti-clockwise.

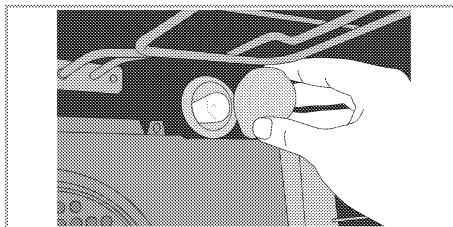

3. Unscrew oven lamp by turning anti-clockwise and replace it with new one.
4. Refit the glass cover.

8 Troubleshooting



DANGER

Risk of electric shock, short circuit or fire by unprofessional repairs!

Repairs on the appliance must be carried out by an approved service centre.



DANGER

Risk of explosion or poisoning by unprofessional repair.

Repairs on the appliance must be carried out by an approved service centre.

Normal operating conditions

- Smoke and smell may emit for a couple of hours during the first operation.
- It is normal that steam escapes during operation.
- When the metal parts are heated, they may expand and cause noise.

Before you call the service, please check the following points.

Electrical equipment

Malfunction/problem	Possible cause	Advice/remedy
The appliance does not work.	The mains fuse is defective or has tripped.	Check fuses in the fuse box. If necessary, replace or reset them.
	Appliance's plug can not be connected to the grounded socket.	Check the plug connection.
Oven light does not work	Oven lamp is defective.	Replace oven lamp.
	No current.	Check fuses in the fuse box. If necessary, replace or reset them.
Oven does not heat.	Function knob and/thermostat knob are not set.	Set function knob and thermostat knob.
	If the appliance has a timer, the timer may not be set.	Set the time.
	No power.	Check mains supply and fuse box.

Gas

Malfunction/problem	Possible cause	Advice/remedy
No ignition spark is produced.	No electric supply to the appliance.	Check fuses in the fuse box.
No gas is emitted.	Main gas tap is closed.	Open gas tap.

Malfunction/problem	Possible cause	Advice/remedy
	Safety tube is bent.	Install safety tube without bends.
Burners do not burn smoothly or not at all.	Burners are dirty.	Clean burner parts.
	Burners are not dry.	Dry burner parts.
	Burner cap is not securely positioned.	Position burner correctly.
	Gas tap is closed.	Open gas tap.
	Gas container is empty (in case of LPG connection).	Replace gas container.

If the problem has not been solved:

1. Separate unit from the mains supply (deactivate or unscrew fuse).
2. Call the after-sales service of your store reseller.



Important

Do not attempt to repair the appliance yourself. There are no customer service items inside the appliance.

Free Manuals Download Website

<http://myh66.com>

<http://usermanuals.us>

<http://www.somanuals.com>

<http://www.4manuals.cc>

<http://www.manual-lib.com>

<http://www.404manual.com>

<http://www.luxmanual.com>

<http://aubethermostatmanual.com>

Golf course search by state

<http://golfingnear.com>

Email search by domain

<http://emailbydomain.com>

Auto manuals search

<http://auto.somanuals.com>

TV manuals search

<http://tv.somanuals.com>