

How To Use Data Communications with the Watlow Series 945



User's Manual



WATLOW

Watlow Controls, 1241 Bundy Blvd., P.O.Box 5580, Winona, MN 55987-5580, Phone: 507/454-5300, Fax: 507/452-4507

W945-SA50-9210

March, 1992

Supersedes:
W945-SA40-9119

\$5.00

Made in the U.S.A.



Printed on Recycled Paper

Contents

Page	Item
3	Data Communications and the Series 945
3	Hardware Interfaces Protocols
3	Communications Wiring
4	RS-422A Interface Pinouts
5	RS-423A Interface Pinouts (RS-232C Compatible)
6	EIA-485 Interface Pinouts
6	Connecting the Control and Computer
7	Setting Hardware Protocol Switches
7	Network Connections
7	Series 945 Communication Parameters
8	Communications Setup Parameters
10	ASCII and Series 945 Information
11	Series 945 General Message Syntax
11	Message Syntax
11	Data Rules
12	Command List
12	Example Format
13	XON/XOFF Protocol for RS-423A
13	Start and Stop Communicating with the Series 945 and XON/XOFF
14	XON/XOFF "=" Command Example
15	XON/XOFF "?" Command Example
16	ANSI X3.28 Protocol for RS-422 & EIA-485
16	Device Address
16	Starting Communications in ANSI X3.28
17	Stopping Communications in ANSI X3.28
17	ANSI X3.28 "=" Command Example
18	ANSI X3.28 "?" Command Example
19	"?" Command
20	"=" Command
22	Data Logging
23	Table Printout
23	Statistical Process Control - SPC
24	The Difference Between Control and Specification Limits
25	Chart and SPC Printout
26	NAKs and Error Codes
26	User Responsibility
27	Index

Figures	Item
1	RS-422 Interface Wiring
2	RS-423 Interface Wiring
3	EIA-485 Interface Wiring
4	RS-422/RS-423 Switch Selection
5	General Message Syntax Example
6	XON/XOFF "=" Command Example
7	XON/XOFF "?" Command Example
8	ANSI X3.28 "=" Command Example
9	ANSI X3.28 "?" Command Example
10	Data Logging Interface Wiring
11	Table Printout Example
12	Chart & SPC Printout Example

Tables	Item
1	Setup Menu Prompts and Descriptions
2	ASCII Character Set
3	ASCII Control Characters (Partial Set)
4	Address to ASCII Conversion
5	"?" Command Data and Responses, Partial Set
6	"=" Command and "?" Command Data
7	Printer Troubleshooting

How to Use Data Communications with the Watlow Series 945

This manual is a supplement to the Series 945 User's Manual. It is for users with the data communications option. Use in conjunction with the Series 945 User's Manual.

This is expert user-level material and requires previous experience with data communications.

Two Serial Hardware Interfaces and Two Software Protocols

Depending on your units model number, you may have one of two hardware interfaces:

- 1) **RS-422A** for a "multidrop" or (multiple device) network, up to ten devices total; with 4000 ft. network length limit, or **RS-423A** (RS-232C compatible) for one on one communication with a 50 ft. network length limit with a 945 and a host computer (945A-XXXX--B000). Selecting RS-422A or RS-423A is user selectable via internal switches. See Page 7.
- 2) **EIA-485** (945A-XXXX-D000) also for a multidrop network, up to 32 addresses total, and with a 4000 ft. network length limit.

There are two protocols available to you. Depending on the type of network you need, you must use the correct combination of interface and protocol.

We use **ANSI X3.28 Protocol**, based on ANSI X3.28 - 1976 Subcategories 2.2, and A3, with the RS-422A and EIA-485 interface to run a multiple device network. We also use **XON/XOFF Protocol**, a simpler protocol, to run a two device network with an RS-423A interface. XON/XOFF will also work with the RS-422A and EIA-485 interface, but the network is limited to two devices (one computer or printer and a Series 945). XON/XOFF Protocol requires no responses to messages like the ANSI X3.28 Protocol does. Likewise, ANSI X3.28 Protocol, which provides a response to every message, will work with the RS-423 interface. But again you are limited to one Series 945 and a host computer or printer.

To select which protocol you are going to use, go into the SETUP menu and use the MODE key to advance to the **Prot** parameter. Select either **FULL**, for ANSI X3.28 2.2 - A.3, or **On** for XON - XOFF.

If you are using ANSI X3.28 Protocol, choose an address number for the control under the **Addr** parameter following the Prot parameter. This parameter will only appear if Prot = FULL.

Communications Wiring

To connect your Series 945 to a computer or printer, use the next three pages as a reference. Your computer or printer hardware manual will provide more detailed serial port pin information. Also refer to the noise prevention section in Appendix 1 of the Series 945 User's Manual. In the often noisy environments of industrial locations, it is important not to take noise isolation lightly.

RS-422A Interface Pinouts

945A-XXXX-B000

The RS-422A communications uses a four wire (full duplex) system. There are two separate lines for transmitting, and two lines for receiving data between the computer and the Series 945. With RS-422A you can have from one to ten Series 945 controls connected to a single computer.

This diagram is a **typical** wiring example. The connections on the host computer may vary depending on models. Refer to your computer user's manual for more information.

Figure 1 -
RS-422A Interface,
Pin Designations.

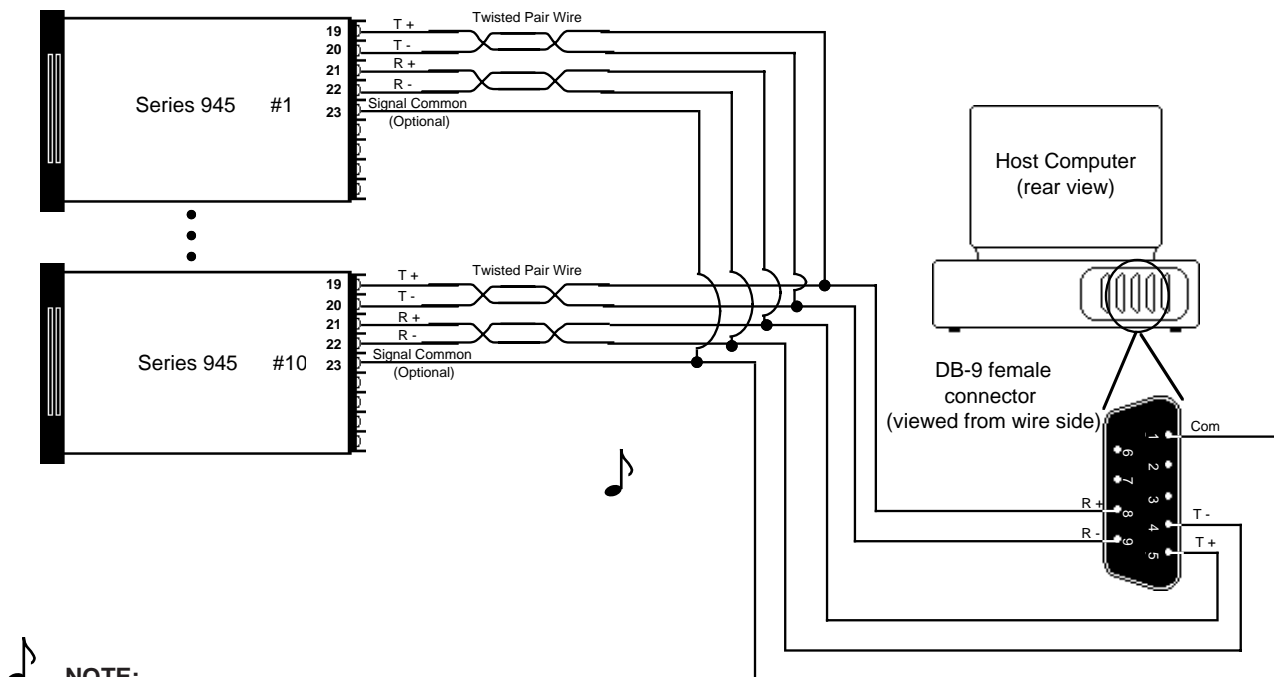

The Electronic Industry Association (EIA) RS-422A standard recommends a maximum 4000 ft. total network distance.

RS-423A Interface Pinouts (RS-232C Compatible)

945A-XXXX-B000

The RS-423A communications uses a three wire (full duplex) system. There is a separate line for transmitting, a line for receiving data, and a line for signal common between the computer and the Series 945. With RS-423A you can have only one Series 945 control connected to a single computer or printer.

This diagram is a **typical** wiring example. The connections on the host computer may vary depending on models. Refer to your computer user's manual for more information.

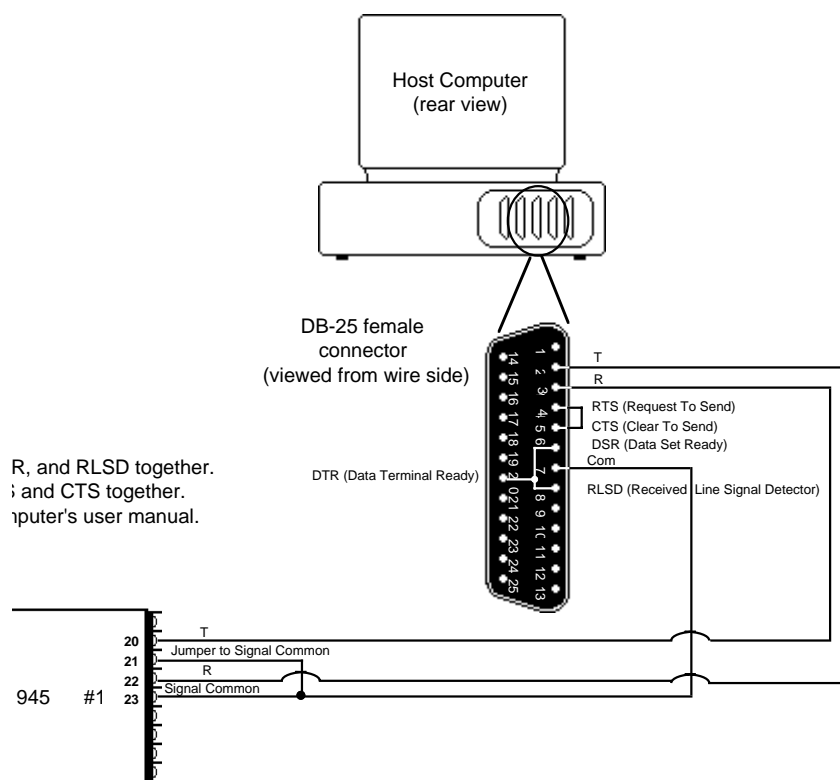

Figure 2 - RS-423A Interface, Pin Designations.

R, and RLSD together.
; and CTS together.
puter's user manual.

 NOTE:

The Electronic Industry Association (EIA) RS-423A standard recommends a maximum 50 foot total point-to-point distance.



EIA-485 Interface Pinouts

945A-XXXX-D000

The EIA-485 communications uses a two wire (half duplex) system. There are only two lines, both lines used for transmitting and receiving. Only one device, the computer or the control, can be speaking at a time. There is a 1 millisecond delay required for the Series 945 to go between transmission and receipt of data. With EIA-485 you can have from one to thirty-two Series 945 controls connected to a computer.

Figure 3 - EIA-485 Interface, Pin Designations.

This diagram is a **typical** wiring example. The connections on the host computer may vary depending on models. Refer to your computer user's manual for more information.

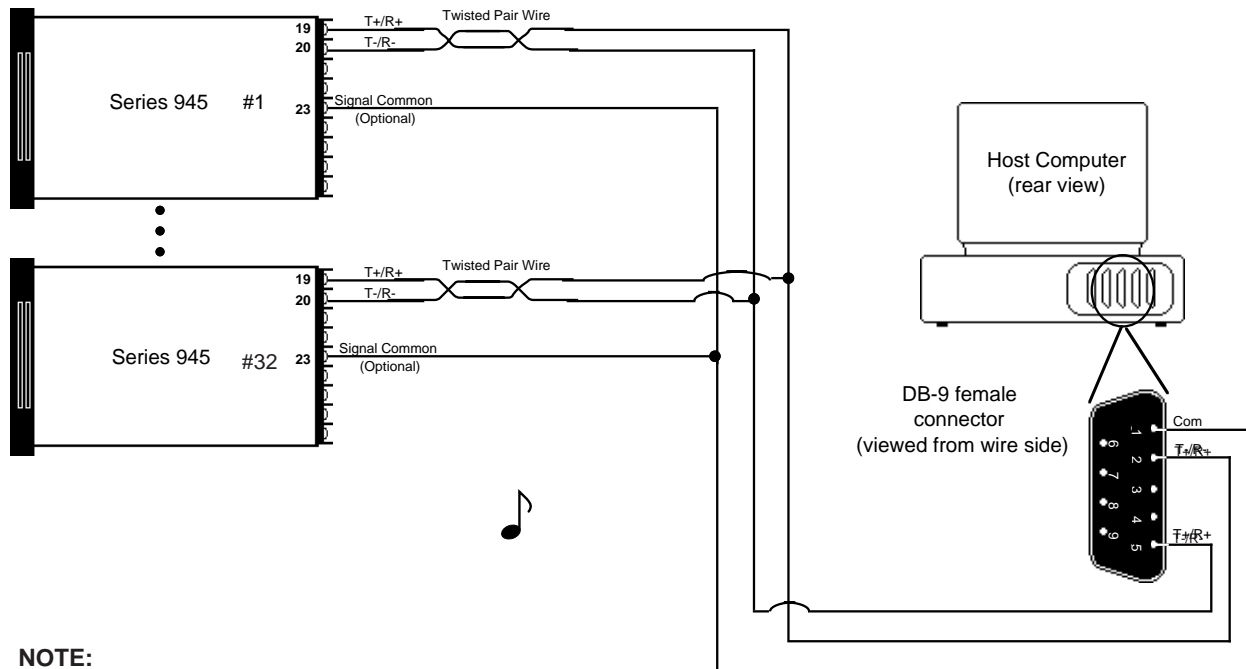

NOTE:

The Electronic Industry Association EIA-485 standard recommends a maximum 4000 ft. total network distance.

Connecting the Control and the Computer

Remove power from both the Series 945 and your computer or printer before connecting them together. This prevents noise or static interference from entering the data communication lines. Assemble a cable and the appropriate wiring at your computer or printer. Refer to the wiring on Page 4 through 6. As soon as you connect the data communications line(s), you're ready to apply power to your system.

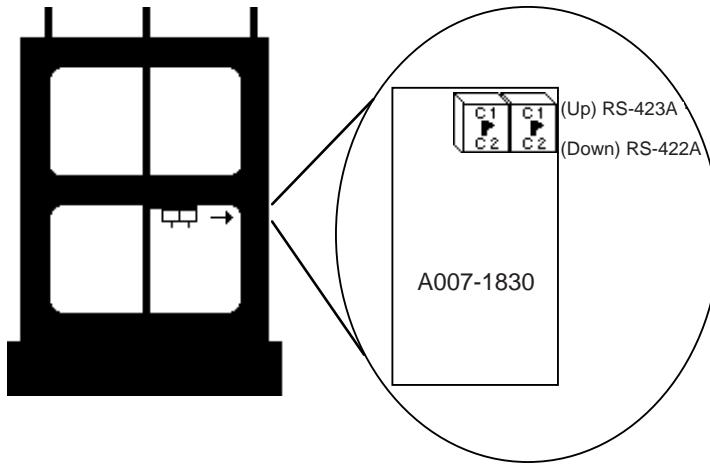



Figure 4 -
RS-422A/RS-423A
Switch Selection.

 **NOTE:**
The Series 945
leaves the factory in
RS-423A operation (C1).

How to Set the Hardware Protocol Switches for 945A-XXXX-B000 Units Only

The RS-422/RS-423 switches are on the Communication Module Board (A007-1830). Figure 4 shows the location of this board. You can select C1 for RS-423 or C2 for RS-422 operation. **Both switches must be set the same** for the desired protocol.

To change the position of a switch, remove the power from the Series 945 and turn the front panel locking screw 90° counterclockwise. To remove the control chassis, grip the front panel bezel and pull it straight out from the control case. Set the switches, C1 (towards you for RS-423) or C2 (away from you for RS-422) then return the control chassis to the case. Be sure it is oriented correctly. Press firmly, but gently, to seat the chassis. Secure the front panel locking screw and reapply power.

Network Connections

You can connect a data communication equipped Series 945 to any computer with an RS-422A or RS-423A (RS-232C compatible) or EIA-485 serial interface. **The serial interface is the key.** The IBM™PC® with an RS-232C serial output card, for instance, will talk to a single RS-423A equipped Series 945. For a multiple 945 network with the same PC, you'll need an RS-232 to RS-422 converter to act as a "bus," or multiple connection point.

Watlow recommends the Burr-Brown LDM 422 for that purpose. The address is: Burr-Brown, Inc., 1141 West Grant Rd., Suite 131, Tucson, AZ 85705, Phone: (602) 624-2434, Fax: (602) 623-8965.

For EIA-485, we recommend the Black Box LD485A. Their address is: Black Box Corporation, Mayview Road at Park Drive, Box 12800, Pittsburgh, PA 152421, Phone: (412) 746-5530.

Series 945 Communication Parameters

To communicate with the Series 945, match the serial port settings of your computer with the available settings in the 945:

bAud Rate = 300, 600, 1200, 2400, 4800, 9600 (choose one)
dAtA = 7o = 7 data bits and odd parity
7E = 7 data bits and even parity (choose one)
8n = 8 data bits and no parity
Start Bit = 1
Stop Bits = 1

Setup Menu - Communications Parameters

Enter the Setup menu by pressing the UP/DOWN keys simultaneously for 3 seconds. The lower display shows the LOC parameter, and the upper display shows its current level. All keys are inactive until you release both keys. You can reach the LOC parameter from anywhere. This is only a listing and brief explanation of the parameters, refer to Pages 22 through 26 for a thorough explanation of Statistical Process Control (SPC).

bAUd	<p>Baud: Represents the current baud rate for serial communications. Range: 300, 600, 1200, 2400, 4800, 9600 Default: 1200</p>
dAtA	<p>Data: Allows the user to select the data bits and parity for communication. Range: 7 o = 7 data bits and odd parity 7E = 7 data bits and even parity 8 n = 8 data bits and no parity Default: 7 o</p>
Prot	<p>Protocol: Selects the communication protocol. Must be On for data logging to occur. FULL = ANSI X3.28 2.2 - A.3 On = XON - XOFF Range: FULL or On Default: FULL</p>
Addr	<p>Address: Selects the address device if Prot = FULL. Range: 0 to 31 Default: 0</p>
Log	<p>Log: Selects the data logging function for a printout of the data. Appears if Prot = On. For further expon on SPC, the parameters and printouts, see Page 22 - 26. Range: OFF, tAbL, CHrt, SPCA, SPCd, SPCn Default: OFF</p>
LSL	<p>Lower Specification Limit: This value is the specified deviation below set point, which statistically the process should not exceed. Appears if Prot = On and Log = SPCA or SPCd. SPCA Range: rL to Lower USL -2°F/-1°C Default: rL SPCd Range: 1 to 99 Default: 10</p>
USL	<p>Upper Specification Limit: This value is the specified deviation above set point, which statistically the process should not exceed. Appears if Prot = On and Log = SPCA or SPCd. SPCA Range: rH to upper LSL +2°F/1°C Default: rL SPCd Range: 1 to 99 Default: 10</p>
tbS	<p>Time Base: Selects the time in minutes over which 30 random samples are taken for computing SPC values. Appears if Prot = On and Log = SPCA or SPCd. Range: 1 to 60 Default: 5</p>
LinE	<p>Line: Selects the number of lines per page of data logged output. Match this parameter to the number of lines per page your printer prints. After you select the number of lines to print, a form feed character is sent to the printer, resetting the top of the page. Range: 10 to 127 Default: 65</p>
YEAr	<p>Year: Select the current year for the data logging header. Appears if Prot = On and Log = tAbL, CHrt or SPCA, SPCd, SPCn. Parameter resets to default after a power interruption. Default: 92</p>
Mon	<p>Month: Select the current month for the data logging header. Appears if Prot = On and Log = tAbL, CHrt or SPCA, SPCd, SPCn. Parameter resets to default after a power interruption. Default: 01</p>
dAY	<p>Day: Select the current day for the data logging header. Appears if Prot = On and Log = tAbL, CHrt or SPCA, SPCd, SPCn. Parameter resets to default after a power interruption. Default: 01</p>
HOUr	<p>Hour: Represents the 24 hour time-of-day clock setting for minutes. Appears if Prot = On and Log = tAbL, CHrt or SPCA, SPCd, SPCn. Parameter resets to default after a power interruption. Range: 0 to 23 Default: 0</p>

Setup

Minutes: Represents the 24 hour time-of-day clock setting for minutes. Appears if Prot = On and Log = tAbL, CHrt or SPCA, SPCd, SPCn. Parameter resets to default after a power interruption. **Range:** 0 to 59 **Default:** 0

Min

Interval: Selects the time interval for the logging function. The logging interval is in tenth of a minute increments. Appears if Prot = On and Log = tAbL, CHrt or SPCA, SPCd, SPCn. **Range:** 0.0 to 60.0 minutes **Default:** 0.0

Int

Tag: Selects what variables are to be transmitted out during the data logging function. Any combination of process, set point and alarms may be "tagged" for logging. Appears if Prot = On and Log = tAbL.

tag

P = Process S = Set Point A = Alarm Set Points

Range: PSA, PS -, P-A, P- -, -SA, -S-, --A, --- **Default:** ---

Setup Menu

Table 1 - Setup Menu Prompts and Descriptions.

Use this page as a master copy for your Series 945 data communications Setup parameters. **Do not enter any values here; make photocopies instead.**

Parameter	Value	Range	Factory Default	Appears If:
bAUd		300, 600, 2100, 2400, 4800, 9600	1200	
dAtA		7 o = 7 data bits and odd parity 7E = 7 data bits and even parity 8 n = 8 data bits and no parity	7 o	
Prot		FULL = ANSI X3.28 2.2 - A.3 On = XON - XOFF	FULL	
Addr		0 to 31	0	Prot = FULL
Log		OFF, tAbL, CHrt, SPC	OFF	Prot = On
LSL		SPCA = rL to Lower USL -2°F/-1°C SPCd = 1 to 99	rL 10	Prot = On & Log = SPCA, SPCd
USL		SPCA = rH to Upper LSL +2°F/1°C SPCd = 1 to 99	rL 10	Prot = On & Log = SPCA, SPCd
tbS		1 to 60	5	Prot = On & Log = SPCA, d, n
LinE		10 to 127	65	Prot = On & Log = tAbL CHrt or SPCA, d, n
YEAr		--	92	Prot = On & Log = tAbL CHrt or SPCA, d, n
Mon		--	01	Prot = On & Log = tAbL CHrt or SPCA, d, n
dAY		--	01	Prot = On & Log = tAbL CHrt or SPCA, d, n
HOUr		0 to 23	0	Prot = On & Log = tAbL CHrt or SPCA, d, n
Min		0 to 59	0	Prot = On & Log = tAbL CHrt or SPCA, d, n
Int		0.0 to 60.0 minutes	0.0	Prot = On & Log = tAbL CHrt or SPCA, d, n
tag		PSA, PS-, P-A, P--, -SA, -S-, --A, --- P = Process S = Set Point A = Alarm Set Points	---	Prot = On & Log = tAbL

Operation Menu

This parameter follows the Aut parameter in the Operation menu. See Page 25 for more information.

Control Limit Update: When YES is selected, it calculates and prints out control limits according to the time base. If no is selected, the current control limit is printed and no subsequent limits are printed. **Range:** YES or no **Default:** YES

CLUP

ASCII Char.

Table 2 -
ASCII Character
Set

ASCII Character Set											
Dec	Hex	Char	Dec	Hex	Char	Dec	Hex	Char	Dec	Hex	Char
00	00	NUL	16	10	DLE	32	20	SP	48	30	0
01	01	SOH	17	11	DC1	33	21	!	49	31	1
02	02	STX	18	12	DC2	34	22	"	50	32	2
03	03	ETX	19	13	DC3	35	23	#	51	33	3
04	04	EOT	20	14	DC4	36	24	\$	52	34	4
05	05	ENQ	21	15	NAK	37	25	%	53	35	5
06	06	ACK	22	16	SYN	38	26	&	54	36	6
07	07	BEL	23	17	ETB	39	27	'	55	37	7
08	08	BS	24	18	CAN	40	28	(56	38	8
09	09	HT	25	19	EM	41	29)	57	39	9
10	0A	LF	26	1A	SUB	42	2A	*	58	3A	:
11	0B	VT	27	1B	ESC	43	2B	+	59	3B	;
12	0C	FF	28	1C	FS	44	2C	,	60	3C	<
13	0D	CR	29	1D	GS	45	2D	-	61	3D	=
14	0E	SO	30	1E	RS	46	2E	.	62	3E	>
15	0F	SI	31	1F	US	47	2F	/	63	3F	?
Dec	Hex	Char	Dec	Hex	Char	Dec	Hex	Char	Dec	Hex	Char
64	40	@	80	50	P	96	60	`	112	70	p
65	41	A	81	51	Q	97	61	a	113	71	q
66	42	B	82	52	R	98	62	b	114	72	r
67	43	C	83	53	S	99	63	c	115	73	s
68	44	D	84	54	T	100	64	d	116	74	t
69	45	E	85	55	U	101	65	e	117	75	u
70	46	F	86	56	V	102	66	f	118	76	v
71	47	G	87	57	W	103	67	g	119	77	w
72	48	H	88	58	X	104	68	h	120	78	x
73	49	I	89	59	Y	105	69	i	121	79	y
74	4A	J	90	5A	Z	106	6A	j	122	7A	z
75	4B	K	91	5B	[107	6B	k	123	7B	{
76	4C	L	92	5C	\	108	6C	l	124	7C	
77	4D	M	93	5D]	109	6D	m	125	7D	}
78	4E	N	94	5E	^	110	6E	n	126	7E	~
79	4F	O	95	5F	_	111	6F	o	127	7F	DEL

Table 3 -
ASCII Control
Characters
(Partial Set)

ASCII Control Characters (Partial Set)				
ASCII Char.	Ctrl Key Equiv.	Definition	Dec. Equiv.	Hex. Equiv.
ENQ	Ctrl E	Enquiry	5	05
ACK	Ctrl F	Acknowledge	6	06
NAK	Ctrl U	Neg. Acknowledge	21	15
STX	Ctrl B	Start of Text	2	02
ETX	Ctrl C	End of Text	3	03
EOT	Ctrl D	End of Transmission	4	04
DLE	Ctrl P	Data Link Escape	16	10
CR	Ctrl M	Carriage Return	13	0D
DC1	Ctrl Q	XON	17	11
DC3	Ctrl S	XOFF	19	13

Series 945 General Message Syntax

As soon as you link the devices, you'll be able to talk to the Series 945 using ASCII characters.

The Series 945 will respond to any Operating or Setup parameter, plus some others. The control will respond to either upper or lower case ASCII characters from your computer.

Both protocol/interface combinations will respond to the general syntax, providing the commands or queries are correctly transmitted. However, the ANSI X3.28 Protocol requires beginning and ending characters, and the XON/XOFF Protocol requires ending characters. We'll look at those shortly.

Message Syntax

Messages from your computer to the Series 945 must take this general form. All commands do not require the full number of data fields.

Command <Space> Data.1 <Space> Data.2 <Space> Data.3... Data.N

"Command" is a character set to which the Series 945 will respond. The brackets "< >" enclose a non-literal description. "Space" is simply a delimiter, an ASCII space character (Hex 20). "Data Fields" are parameters and values specific to a command; the number of possible data fields depends on the particular command you use. Data 1 is here abbreviated, "Data.1", Data 2 is "Data.2" and so on.

In the syntax explanations ahead, we'll show you the specific arguments for each command. It will speed the process, if you remember this general syntax.

Data Rules

Data fields are parameters and values specific to particular commands. These rules govern their use. Specific data for each command is listed later in this chapter.

- Data will be ASCII 0 through 9, unless otherwise noted.
- Data can go up to seven total characters, including a minus sign. A + or - sign, if used, must be first, and it must have a decimal point if applicable.
- Data can use leading zeros. (Up to 7 digits.)
- Data does use decimal points.
- Data.1 portion of message can be up to four total characters.

Command List

These commands, represented by their respective ASCII characters, will enable you to program the Series 945 from your computer. More detailed descriptions of the commands are on the pages noted.

?	Finds the value of a specific parameter.	p. 19
=	Sets a specific parameter to a specific value.	p. 20

Example Format

For your benefit, we're presenting message/response examples with syntax required for Series 945 communication. Information bracketed by < > indicates a description, rather than literal characters. We show each ASCII character that you must transmit to the Series 945, including space between the characters. (A "space" is itself an ASCII character, hex 20). For clarity, we also represent each ASCII character as a hexadecimal pair. The pairs are spread apart on the page for easy reading. However, electronic devices "see" the hex pairs all together in "strings," with no spaces in between.

For instance, from the example just below, you want to set the Alarm 1 Low (A1LO) parameter to 500°. Notice the syntax just below which uses the "=" command.

= <Space> A1LO <Space> 500

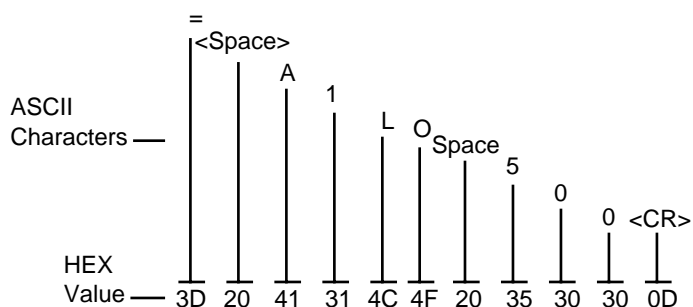

Figure 5 - Series 945 General Message Syntax Example.

To send this message, key the ASCII characters into your computer, or write them into your program. The computer, in turn, will send a string similar to the one at the bottom of the example, 3D2041314C4F20353030.

Notice that we haven't mentioned protocol here, or any characters added to this syntax by a protocol. With XON/XOFF, the message above can be transmitted with only an additional Carriage Return <CR> (hex 0D) character at the end. However, the ANSI X3.28 Protocol requires an envelope of Start of Text <STX> (hex 02) and End of Text <ETX> (hex 03) characters around the information you see above. You'll learn how to do that in the pages ahead.

XON/XOFF Protocol for RS-423A

XON/XOFF (flow control) Protocol allows a communicating device (either a 945 or the host) to suspend transmission of all messages from the other device, and then to continue transmission when it's again ready.

The device that needs to suspend transmission sends the XOFF character (hex 13) to stop the other device's transmitter, and XON (hex 11) to restart it. Note that technically any character will restart the transmitter, but only the XON character is not a part of any regular message that may be transferring.

Messages transmit according to the syntax described in the XON/XOFF formats which follow for each command.

The XON/XOFF Protocol requires a Carriage Return character (hex 0D) at the end of every message.

How To Start and Stop Communicating with the Series 945 and XON/XOFF

Starting communications with **XON/XOFF Protocol** is simple. You just configure your computer to agree with the Series 945 communication parameters and open its serial communication port in software. Then begin to "talk" by transmitting a message to the Series 945. You stop communicating with XON/XOFF Protocol simply by ceasing to send messages.

XON/XOFF "=" Command Example

The general command syntax is the one you've already seen. Each command uses a slightly different variation of it, depending on the number of arguments required for a message.

- You want to change the Alarm 1 Low (A1LO) value to 500°. The "=" command will do the job.

The syntax with XON/XOFF Protocol requires an ending Carriage Return <CR>.

"=" Command Syntax with XON/XOFF Protocol:
= <space> Data.1 <space> Data.2 <CR>

With the "=" Command, Data.1 is the Series 945 parameter, in this case Alarm 1 Low, A1LO. Data.2 is the value you want to set for that parameter, in this example, 500.

Enter in ASCII:

= <space> A1LO <space> 500 <CR>

The hex string will be:

3D2041314C4F203530300D

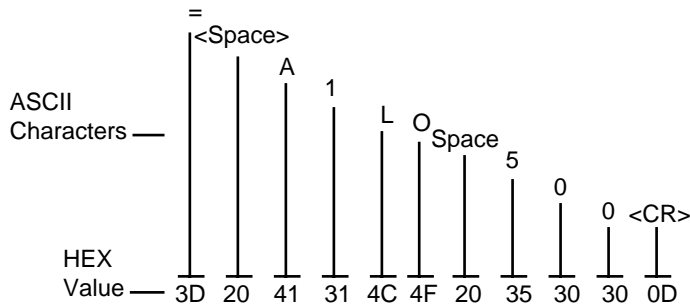
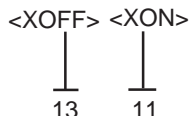

Figure 6 - XON/XOFF "=" Command Example.

Response from the Series 945:

It sends an "XOFF" when a carriage return is received and then an "XON" when the unit is done processing the command.



- The complete list of "=" Command data (parameters and value limits) is in Table 6, Pages 20 - 21.

XON/XOFF "?" Command Example

You want to know the Alarm 1 Low (A1LO) value. The "?" uses a variation of the message syntax shown just below. **This protocol requires an ending carriage return character.**

"?" Command syntax with XON/XOFF Protocol:
? <space> Data.1 <CR>

Enter in ASCII:
? <space> A1LO <CR>
 The hex string will be:
 3F2041314C4F0D

Figure 7 -
XON/XOFF "?"
Command Example.

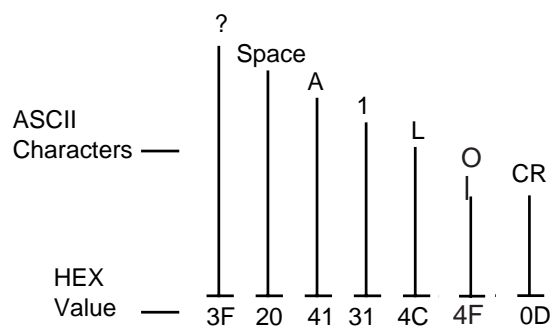

The value of A1LO will be between rL (Range Low) and rH (Range High), say, 500.

Response from the Series 945:
 <XOFF> <XON> <current value of A1LO> <CR>

The hex response string is:
 13113530300D

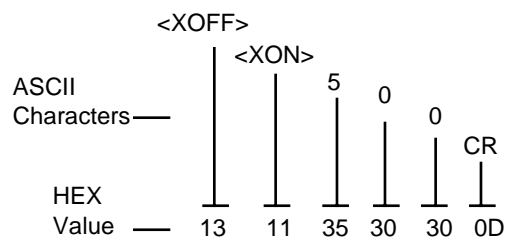

ANSI X3.28 Protocol for RS-422A and EIA-485

The ANSI X3.28 Protocol provides high quality communications by requiring a response to every message. With a multiple device or "multidrop" network, this protocol prevents confusion among the separate devices. Furthermore, if noise occurs somewhere in the system, no parameter will change because noise can't comply with the protocol.

By placing messages inside a protocol envelope, the messages are protected. In the examples to come you'll see how this works.

The ANSI X3.28 Protocol requires STX characters at the beginning of a message and ETX characters at the end.

Device Address

If you are using the ANSI X3.28 Protocol, you must have a device address (identification) number. A Watlow RS-422A multidrop network can handle up to 10 devices with this protocol. EIA-485 can handle up to 32 devices. Set the address number with the Series 945 in the **Addr** parameter under the Setup menu.

Address	ASCII Equivalent
0 - 9	0 - 9
10 - 31	A - V

**Table 4 -
Address to ASCII
Conversion.**

Starting Communications in ANSI X3.28 Protocol

Here's the syntax for starting communications with ANSI X3.28 Protocol. The master device, your computer, must initiate the data link. The example below uses the ASCII number 4 as a Series 945 device address.

Enter in ASCII, using this syntax: <Address # 4><ENQ>

ASCII		4	
Characters	—	↓	<ENQ>
HEX Value	—	34	05

Response from the 945:

<Address # 4><Acknowledge (ACK)>

ASCII		4	
Characters	—	↓	<ACK>
HEX Value	—	34	06

Stopping Communications in ANSI X3.28 Protocol

The master device, your computer, must end communications with Device #4 by using Data Link Escape (DLE) and End of Transmission (EOT) characters.

Enter in ASCII: <DLE><EOT>

ASCII Characters	—	<DLE>	<EOT>
HEX Value	—	10	04

Response from the 945:

None

ANSI X3.28 "=" Command Example

The "=" Command sets a specific 945 parameter to a specific value. The general command syntax applies to all commands. The definition and number of arguments depends on the command itself. See Table 6, Pages 20 - 21.

In this example, you want to change the Alarm 1 Low value to 500°. Here, the "=" command will do the job.

"=" command Syntax with ANSI X3.28 Protocol:

<STX> = <space> Data.1 <space> Data.2 <ETX>

With the "=" command, Data.1 is the Series 945 parameter, in this case Alarm 1 Low, A1LO. Data.2 is the value you want to set for that parameter, in this example, 500.

Enter in ASCII:

<STX> = <space> A1LO <space> 500 <optional carriage return> <ETX>

The hex string is:

023D2041314C4F2035303003

Figure 8 - ANSI X3.28 "=" Command Example.

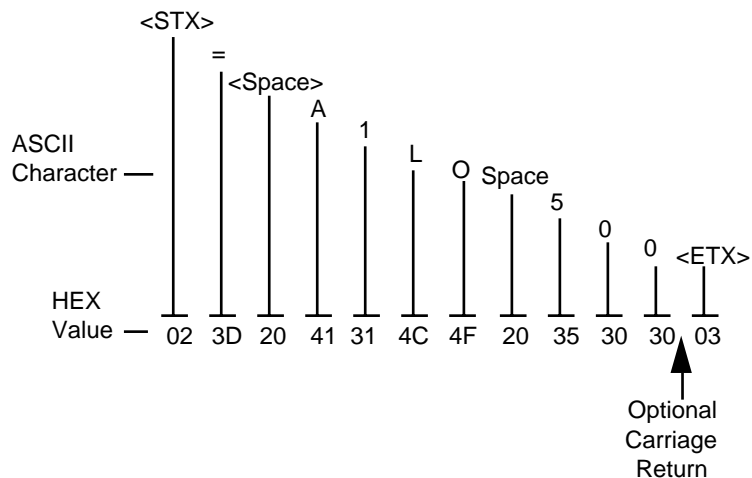

Response from the Series 945:

<ACK>

The hex response string is:

06

- You'll find the the complete list of "=" command arguments (parameters and value limits) in Table 6, Pages 20 - 21.

ANSI X3.28 "?" Command Example

You need to know the Alarm 1 Low value (A1LO). The "?" uses a variation of the message syntax shown just below. **This syntax requires the protocol start of text and end of text characters.**

"?" command syntax with ANSI X3.28 Protocol:

<STX> ?<space> <Data.1> <ETX>

Enter in ASCII:

<STX> ? <space> <A1LO> <optional carriage return> <ETX>

The hex string will be:

023F2041314C4F03

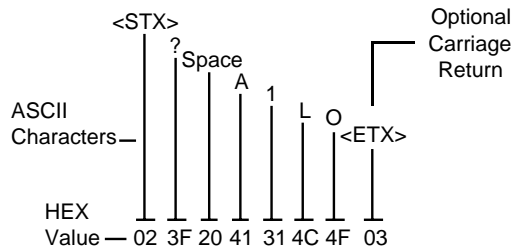

Figure 9 - ANSI X3.28 "?" Command Example.

First response from the Series 945:

<ACK>

The <ACK> hex response string is:

06

Your computer's confirming response:

<EOT>

The <EOT> response hex string is:

04

Second response from the Series 945:

<STX> <current A1LO value> <carriage return> <ETX>

The hex string is:

023530302003

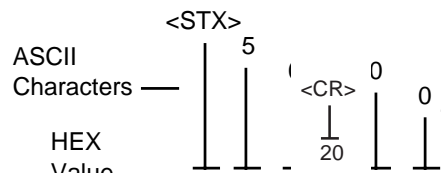

Your computer's next response:

<ACK> or <NAK> (if the message needs to be repeated).

The hex string is:

06 or 15

Final response from the Series 945:

<EOT>

The hex string is:

04

Commands

**Table 5 -
"?" Commands
and Responses.
These commands
are READ ONLY.**

Data.1	Respsns	Information	Comments
C1	ACTUAL	Actual process value	Between R1L and R1H
IN	0	J T/C	
	1	K T/C	
	2	T T/C	
	3	N T/C	
	4	PT2 T/C	
	5	C T/C	
	6	Not Used	
	7	R T/C	
	8	S T/C	
	9	B T/C	
	10	RTD whole	
	11	RTD tenths	
	12	0-5V	
13	4-20mA		
MODE	1	Auto mode	Multiple modes are possible.
	2	Manual mode	
	4	Configuration mode	
	8	Calibration mode	
	16	Alarm silence active	
ERR	0	No error	Multiple errors are possible.
	1	Open sensor	
	2	Reversed sensor	
	4	Ambient sensor	
	8	Configuration	
	16	EE Checksum	
	32	A/D underflow	
	64	A/D overflow	
128	Not used		
ER2	0	No error	Cleared when ER2 is read. Only 1 ER2 response is valid.
	1	Transmit buffer overflow	
	2	Receive buffer overflow	
	3	Framing error	
	4	Overrun error	
	5	Parity error	
	6	Talking out of turn	
	7	Invalid reply error	
	8	Noise error	
	16	Process input active	
	17	Local/remote is local	
	18	Local/remote is remote	
	19	Remote not enabled	
	20	Command not found	
	21	Parameter not found	
	22	Incomplete command line	
	23	Invalid character	
24	Number of chars. overflow		
25	Input out of limit		
26	Read only command		
27	Write allowed only		
BTYP	0	T/C Only	
	1	T/C, RTD whole, process	
	2	T/C, RTD tenths, process	
	3	R, S, B T/C	
MDL		Displays 945 <u>X</u> X = software revision	
RSP1	Remote SP	Remote set point setting	

"?" Command

The "?" Command reads a specific value of the Series 945 parameter (Data.1). Tables 5 and 6 provide the complete list of parameters you may use, plus responses.

"=" Command

The "=" Command sets a specific Series 945 parameter (Data.1) to a specific value (Data.2) when the unit is in the HOLD mode. Use Tables 5 and 6 to select parameters (Data.1) in the lefthand column. In Table 6 the low and high limit or code values (Data.2) are in the three center columns.

Data.1	Data.2			Function
	Low Limit	High Limit	Code	
AXHI	Process RL value ±555/Deviation ±999	RH value		Alarm High <u>X</u> value
AXLO	Process RL value ±555/Deviation ±999	RH value		Alarm Low <u>X</u> value
ALM	0 1 2 4 8	No alarms occurring A1H occurring A1L occurring A2H occurring A2L occurring		Writing a 0 will clear all alarms if the alarm condition no longer exists.
AL1	0	2	0 1 2	Alarm 1 = deviation Alarm 1 = process No Alarm 1
AL2	0	2	0 1 2	Alarm 2 = deviation Alarm 2 = process No Alarm 2
ATMN	1	1	1	Auto/Manual toggle must be sent twice within 5 sec.
AUT	0	3	0 1 2 3	No auto-tuning Slow response tuning Medium response tuning Fast response tuning
CAL*	-180°F -100°C -180 Units	180°F 100°C 180 Units		Calibration offset
CF	0	1	0 1	Display °C Display °F
CLUP	Yes	No		SPC control limits update
CTX	1	60		Output <u>X</u> cycle time
DAY	1	31		Day of the month/data log
DB	0 0 0 Units	99°F 55°C 99 Units		Dead band
DEC	0	2	0 1 2	No decimal point 0.0 0.00
DEX	0.00	9.99		Output <u>X</u> derivative
DFL	0	1	0 1	US prompts SI prompts
HOUR	0	23		Hour for data logging
HYSX	1°F 1°C 1 Unit	99°F 55°C 99 Units		Output <u>X</u> switching hys.
INDC	1	1	1	UP/DOWN key action
INT	0.0	60.0		Time interval in minutes for logging 0.0 = logging OFF
ITX	0.00	9.99		Output <u>X</u> integral



NOTE:
An X means it applies to either Output 1 or Output 2.

**Table 6 -
"=" and "?" Com-
mands. These are
READ or WRITE
commands. See
Table 4 for more "?"
Commands.**

*** When the 945 RTD
input is 0.1°, these
parameters will have
a decimal point to
the left of the least
significant digit.**

Commands



NOTE:

An X means it applies to either Output 1 or Output 2.

Data.1	Data.2			
	Low Limit	High Limit	Code	Function
LAT <u>X</u>	0	1	0	Latched alarms
			1	Non-latched alarms
LINE	10	127		Lines per page for data logging
LOC	0	3		Lock front panel
LOG	0	3	0	Logging OFF See Page 22.
			1	Table
			2	Chart
			3	SPCA
			4	SPCd
			5	SPCn
L-R	0	1	0	Local set point
			1	Remote set point
LSL	rL	USL Lower -2°F/-1°C		SPC lower spec limit
MAN	-100	100		Manual % output
MIN	0	59		Minute for data logging
MON	1	12		Month for data logging
OT <u>X</u>	0	1 or 2*	0	Heat
			1	Cool
			2*	No action
				*only applies to Ot2
OT4	0	2	0	Output 4 = Process Retransmit
			1	Output 4 = Set Point Retransmit
			2	No action
PB <u>X</u>	0	999°F 555°C 999 Units		Proportional Band dFL = US
PB <u>X</u> %	0.0	999.9		Output <u>X</u> proportional band DFL = SI
RAX	0.00	9.99		Rate
RE <u>X</u>	0.00	9.99		Reset
RH	Min. IN range	Max. IN range		Range High
RL	Min. IN range	Max. IN range		Range Low
RSP	0	2	0	OFF
			1	0-5
			2	420
RTD	0	1	0	DIN
			1	JIS
SIL	0	1	0	Alarm silence OFF
			1	Alarm silence ON
SP <u>X</u>	rL	rH		Set point
TAG	0	7	0	--- = no logging
			1	-- A
			2	- S -
			3	- SA
			4	P - -
			5	P - A
			6	PS -
			7	PSA
tbS	1	60		SPC time interval in minutes
USL	LSL Upper 2°F/1°C	rH		SPC upper spec limit
YEAR	0	99		Year for data logging



NOTE:

P = Process
S = Set Point
A = Alarm Set Point
--- = no logging

Data Logging

The data logging feature is a convenient replacement for chart recorders. Information is sent directly from the Series 945 to a serial printer, or to a computer disk file. **No computer is needed**, although the 945 can be connected to a computer with a serial port and terminal emulation software.

Data logging provides a handy reference to review process performance. The time intervals between each entry and data printed are user selectable, with the time display resetting every 24 hours. If there is a power interruption, the time is reset to 0.0. There are several options for the printer output. Choose from table, chart or SPC (Statistical Process Control). See the following pages for more information on printer outputs.

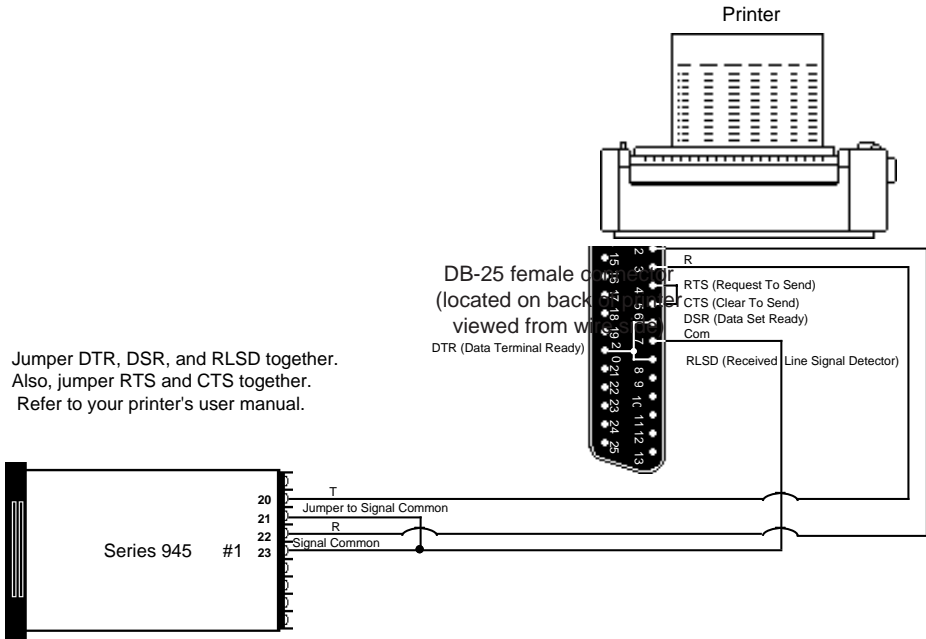

Figure 10 - Data Logging Interface Wiring Example.

Connect the 945 to the printer as in Figure 10; this is a typical wiring example. The connections on the printer may vary depending on the model, refer to the printer's user manual. Enter the Setup menu by pressing the UP/DOWN keys simultaneously for three seconds. Mode through the parameters until you reach bAUd and follow the parameter listing on Page 8. Select the appropriate data for each prompt and enter your values in the table on Page 9. Data logging begins once you return to the control set point.

After each line the 945 emits a carriage return. Your printer can be set up to handle line feeds. The printer must supply a line feed (LF) following a carriage return (CR). Refer to your printer user's manual for more information.

A data header is printed once the logging function begins. When you change the time interval (Int) or any selected data (tag), or power is cycled, the header is printed again. The header always remains the same, regardless of the control configuration. The time display wraps around to 0.0 every 24 hours. If there is a power interruption, the control will restart at 0.0 when power is restored.

Data Logging

Data fields emitted are determined by the tag parameters and control configuration. As in the following example, tag is set for PSA (**P**rocess, **S**et Points, and **A**larm Set Points). SET-2 is only transmitted when there is a secondary control output, and is configured the same as the primary output. In the example below, notice A1LO was changed to 125 resulting in an alarm condition shown as an * (asterisk) in the PROCESS and LOW-1 columns. After a latching or non-latching alarm is cleared, the * is removed. The ATUNE column reports the auto-tune status. START denotes the beginning of the sequence, RSTRT signifies auto-tune has been re-started, and END is displayed when complete.

Table Printout

Example: Log = On, Int = 0.5, tag = PSA
P = Process S = Set Points A = Alarm Set Points

Parameters represented:

	(C1)	(SP1)	(SP2)	(A1LO)	(A1HI)	(A2LO)	(A2HI)	(AUt)
DATE:	01-01-92							
TIME	PROCESS	SET-1	SET-2	LOW-1	HIGH-1	LOW-2	HIGH-2	ATUNE
10:03:47	144 *	200		150 *	240	190 *	210	
10:03:58	157 *	200		150	240	190 *	210	START
10:04:34	185 *	200		150	240	190 *	210	
10:05:10	177 *	200		150	240	190 *	210	
10:05:46	182 *	200		150	240	190 *	210	
10:06:02	179 *	200		150	240	190 *	210	END
10:06:38	196	200		150	240	190	210	
10:07:14	198	200		150	240	190	210	
10:07:50	199	200		150	240	190	210	
10:08:26	199	200		150	240	190	210	
10:09:02	200	200		150	240	190	210	

Figure 11 - Table Printout Example.

SPC - Statistical Process Control

SPC tracks variability to help you distinguish between natural variability (common causes) from unnatural variability (special causes). Based upon measurements, SPC gives you a picture of how the process is performing. By showing when special causes are occurring, the SPC printout gives you written changes in the process. An SPC printout is a picture of the operation. Typically, past data gives information about what the average measurements and limits should be. These are traditionally shown by upper and lower control limits. It also gives us a picture of what is happening now. By comparing the process we can determine when special, or assignable causes occur. **This is advanced user-level material and requires previous experience with Statistical Process Control (SPC).**

For more information we recommend:

Juran's Quality Control Handbook

by J.M. Juran, Editor in Chief & Frank M. Gryna, Associate Editor
Hardcover, 1988 ISBN: 0-7-033176-6

Available from: McGraw Hill
1221 Avenue of the Americas
New York, NY 10020
1-800-2-MCGRAW

The Difference Between Control & Specification Limits

Control limits are established on the control chart at ± 3 standard deviations (3 sigma). They are based upon the distribution of sample averages and are calculated from the actual performance of the process. They are typically narrower than specification limits.

Specifications are limits for individual measurements, not averages. They are based upon engineering or customer requirements, rather than process capability. Process capability predicts the process performance to predetermined specification limits.

When the LCL (**L**ower **C**ontrol **L**imit) and UCL (**U**pper **C**ontrol **L**imit) values have been determined, the values for CPKL, CPKU, and CP are calculated and printed once on the chart. The smaller of these two numbers will be your actual process capability or CPK.

$$CPKL = \frac{\text{Mean} - \text{LSL}}{3\sigma} \quad CPKU = \frac{\text{USL} - \text{Mean}}{3\sigma}$$

If the system is too stable "variation insignificant" is printed. Your process is so stable that even a severe shift or variation greater than ± 6 sigma will still maintain a larger CPK value. If both LSL and USL are left at their default value, they are set to the 4σ values below and above the process mean value. Once the mean value has been calculated, these values are used to calculate CPKL and CPKU values.

Average: The mean, or the arithmetic average, (\bar{x}).

Control Limits: Limits on a control chart, based on actual process data, which are used as criteria for signalling the need for action, or for judging whether a set of data does or does not indicate a "state of statistical control."

Lower Control Limit (LCL): Control limit derived by the average minus 3 standard deviation ($\bar{x} - 3\sigma$).

Mean: The arithmetic average, obtained by adding all the values together and dividing by the number of values (\bar{x}).

Process Capability (CPKL and CPKU): A comparison of process performance with product specifications over a period of time and while the process is in statistical control.

CPK < 0	Average value is outside the specification limits
CPK between 0 and 1	Variation is greater than the limits.
CPK = 1	Variation and the specification limits are the same
CPK between 1 and 1.33	Acceptable process control
CPK between 1.33 and 2	Good process control
CPK > 2	Excellent process control

Sigma: The unit of standard deviation. Sigma is the greek letter "s" written σ .

SPCA (Specification limits Absolute): Represents SPC with fixed values that **do not** track the set point. When SPCA is chosen, the USL range is the LSL parameter + 2 (LSL + 2) to the sensor's range high. Default is the sensor's default range high. The LSL range is from the sensor's default range low to the sensor's default range high. Default is the sensor's default range low.

SPCd (Specification limits Deviation): Represents SPC with deviation values that follow changes to the set point. When SPCd is chosen the range for USL it will be numeric values from 1 to 99. Default is 10. The LSL range is from -1 to -99. Default is -10.

SPCn : There are no user defined values. The USL and LSL parameters are masked.

Example: Log = SPCA, Int = 0.1
P = Process S = Set Points

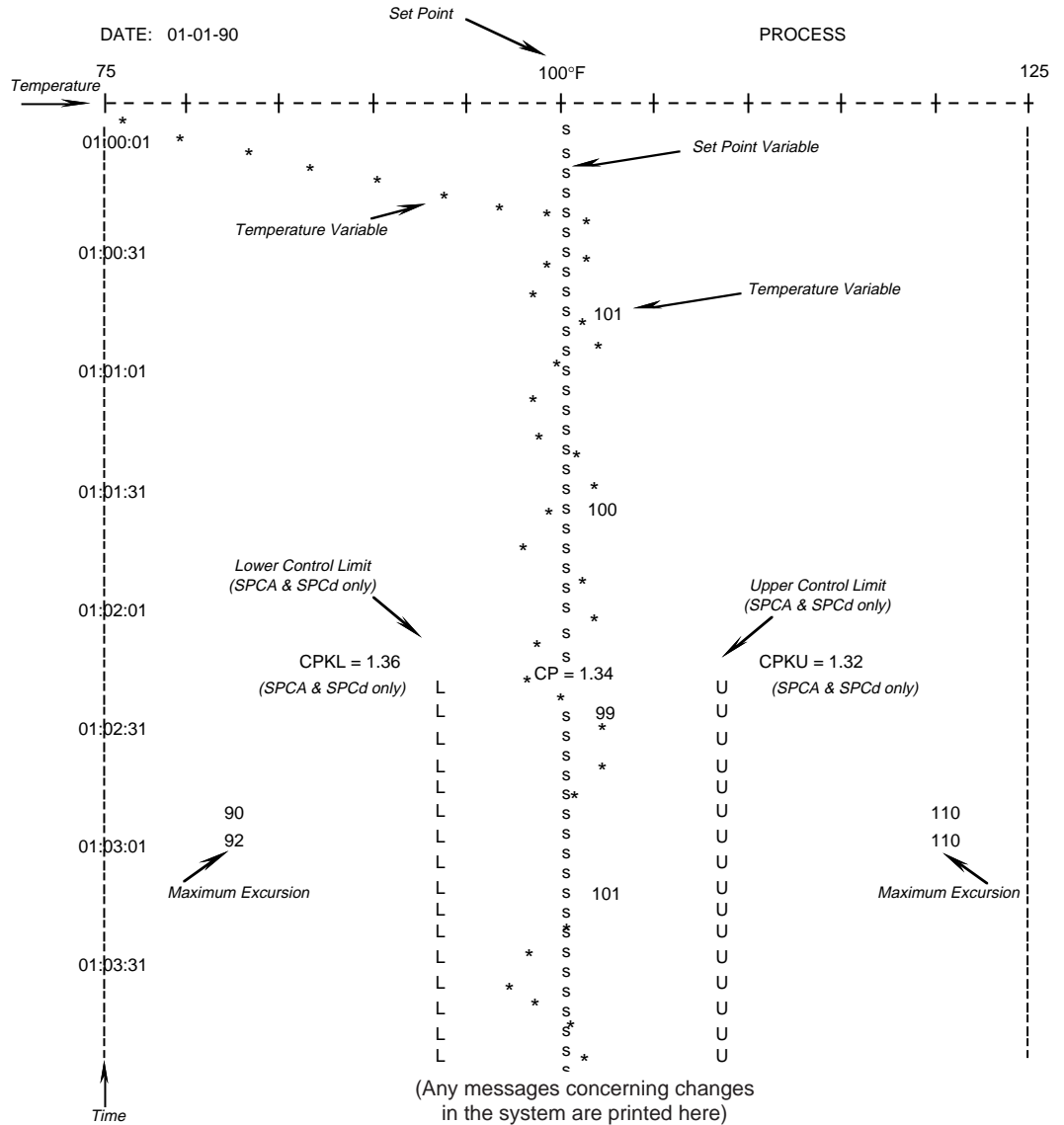

NOTE:
The time is printed every 5th interval (Int). The temperature variable (*) is printed every 10th interval. One Int = 6 seconds.

Figure 12 - Chart and SPC Printout Example

The Chart and SPC (Statistical Process Control) format are very similar. The only difference is the SPC output displays the lower (L) and upper (U) control limit. They are calculated based upon the mean value of the process variable, and are derived from 30 random samples taken over the selected time base (tbS), the mean value used is from the previous timebase samples (ex. the mean from the first 30 samples is used to compute the control limits for the second 30 samples and so on for every sample period. If SPCA (Specification limits Absolute or SPCd (spec. limits Deviation) is selected then the CPKL, CP, or CPKu values will also be printed. If the variation in the process value is too small to calculate the control limits, L and U and the message "Variation Insignificant" are printed. If at any time the process value exceeds the control limits during a print interval, the maximum process excursion value will be printed (if both L and U are exceeded, both maximum values will be printed) on the next line printed. At any time the control limits can be locked in by setting CLUP to "no". If CLUP = no, new control limits can be set by CLUP = YES.

Problem	Cause	Action
Printing all on the same line.	The line feed is missing.	Set the printer for a carriage return and line feed.
The printing is garbled.	Data formats are not compatible.	Match the Series 945 data format to the printers data format using the "Data" prompt.
The printer will not print.	The printer is off line.	Bring the printer on line.
	The transmit and receive lines are reversed.	Make sure Terminal #20 and #22 go to the printers appropriate receive and transmit terminals.

**Table 7 -
Printer
Troubleshooting.**

NAKs and Error Codes

When your message is "not acknowledged" (NAK) in RS-422A or EIA-485 with ANSI X3.28 Protocol, you may clear ER2 code by reading it. That is, use "?"

Then try the message again; you may have made a syntax error. See the error code listing in Table 5, Page 19.

With XON/XOFF protocol and the RS-423A interface, the 945 sends no feedback on commands. Therefore, you may want to query the status of ER 2 after each command you send.

All communications-related error codes are ER2 error codes, that is they are not considered cause for a shutdown of the 945 unit itself. There is always a communications error code generated when a <NAK> character is sent under the ANSI X3.28. With XON/XOFF flow control error codes may be generated, but there will be no standard indication of this fact.

User Responsibility

All of the previous commands are available on all models of the Series 945 that have communications capability. It is the responsibility of the user to refrain from altering parameters which may not appear on the unit. (Example: AXLO should not be set to 1 or 2 if the unit is not equipped with alarm outputs.)

Index

A

ALM, 20
ANSI X3.28 "=" Command, Fig. 8, 17
ANSI X3.28 "?" Command, Fig. 9, 18
ANSI X3.28 Protocol for RS-422A & EIA-485, 3, 16
ASCII Character Set, Table 1, 10
ASCII Control Characters (Partial Set), Table 2, 10
AXHI, 20
AXLO, 20
ATMN, 20
AUT, 20

B

Baud Rate, 8
BTYP, 19

C

C1, 19
CAL, 20
Carriage Return, 13
CF, 20
Chart Printout, 25
CLUP, 9, 20
Command, "?", 19
Command, "=", 20
Command Data & Responses, Partial Set for "?", 19
Command Data "=" and "?", Table 6, 20
Command List, 12
Communications
 Parameters, 8
 Switch Selection, 7
 Wiring, 3
Connecting the Control and the Computer, 7
CTX, 20

D

Data Parameters, 8
Data Link Escape (DLE), 17
Data Logging, 22
Data Rules, 11
DB, 20
DEC, 20
Device Address, 16

E

EIA-485, 3, 6
End of Text (ETX), 13
End of Transmission (EOT), 17
ERR, 19
ER2, 19
Example Format, 12

F

Flow Control, 13

G

General Message Syntax, 11

H

How to Use Data Comms. with the Series 945, 3
HYSX, 20

I

Identification Number, 16
IN, 19
INDC, 20
INT, 20
Interface Wiring,
 RS-422A, Fig. 1, 4
 RS-423A, Fig. 2, 5
 EIA-485, Fig. 3, 6

L

LATX, 21
LOC, 21
LOG, 8, 21, 22
L-R, 21
LSL, 21

M

MAN, 21
MDL, 19
Message Syntax, 11
MODE, 19
Multidrop, 3

N

NAKs and Error Codes, 26
Network connections, 7

O

OTX, 21

P

PBX, 21
Protocol,
 XON-XOFF, 13
 ANSI X3.28, 16

R

RAX, 21
REX, 21
RS-422A, 3, 4
RS-423A, 3, 5
RSP, 19, 21
RH, 21
RL, 21

S

Setup Menu, 8
SPC, 23
SPX, 21
Space, 12
Starting Communications in ANSI X3.28 Protocol, 16
Start of Text (STX), 13
Stopping Communications in ANSI X3.28 Protocol, 17

T

Table Printout, 23
TAG, 21
tbS, 20
Two Hardware Interfaces & Protocols, 3

U

USL, 21

W

Wiring Data Communications, 4 - 6

X

XON/XOFF
 "=" Command Example, Fig. 6, 14
 "?" Command Example, Fig. 7, 15

Series 945 Data Communications User's Manual

Watlow Controls, 1241 Bundy Blvd., Winona, MN 55987, Phone: 507/454-5300, Fax: 507/452-4507

Free Manuals Download Website

<http://myh66.com>

<http://usermanuals.us>

<http://www.somanuals.com>

<http://www.4manuals.cc>

<http://www.manual-lib.com>

<http://www.404manual.com>

<http://www.luxmanual.com>

<http://aubethermostatmanual.com>

Golf course search by state

<http://golfingnear.com>

Email search by domain

<http://emailbydomain.com>

Auto manuals search

<http://auto.somanuals.com>

TV manuals search

<http://tv.somanuals.com>