

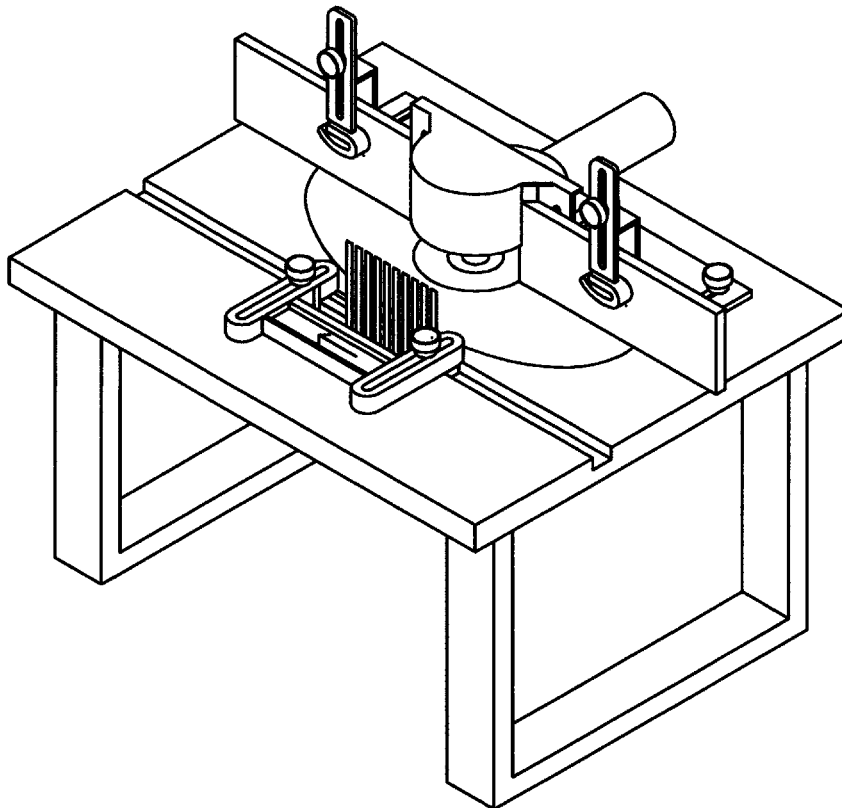

*Woodworking machinery at its best!*

## HEAVY DUTY ROUTER TABLE W013

# OPERATING INSTRUCTIONS AND ASSEMBLY MANUAL



The Charnwood router table enables any portable router to be inverted and used as a stationary machine capable of producing many different types of joints and decorative finishes.

Charnwood, 1 Rowan Street, Leicester, LE3 9GP, England  
Tel. 0116 251 1550 Fax. 0116 253 2891 e-mail; [sales@charnwood.net](mailto:sales@charnwood.net)  
UK customers can view our full product range at [www.charnwood.net](http://www.charnwood.net)

WARNING; When using electric tools, basic safety precautions should be followed to reduce risk of fire, electric shock, and personal injury, including the following:

## **SAFETY INSTRUCTIONS**

- 1) KEEP WORK AREA CLEAN** - Cluttered areas and benches invite injuries.
- 2) CONSIDER WORK AREA ENVIRONMENT** - Do not expose power tools to rain. Do not use power tools in damp or wet locations. Keep work area well lit. Do not use tools in the presence of flammable liquids or gases.
- 3) KEEP CHILDREN AWAY** - All visitors should be kept away from work areas.
- 4) STORE IDLE TOOLS** - When not in use, tools should be stored in dry, and high or locked-up places out of reach of children.
- 5) DO NOT FORCE THE TOOL** - It will do the job better and safer at the rate for which it was intended.
- 6) USE THE RIGHT TOOL** - Do not force small cutters to do the job of heavy duty cutters. Always use a cutter for its intended use only.
- 7) DRESS PROPERLY** - Do not wear loose clothing or jewelry as they can be caught in moving parts. Wear protective hair covering to contain long hair.
- 8) USE SAFETY GLASSES** - Also use face or dust mask when operations are dusty. A vacuum cleaner or dust extractor is strongly recommended.
- 9) SECURE THE TABLE** - The router table should be bolted down or clamped to a sturdy bench.
- 10) DO NOT OVERREACH** - Keep proper footing and balance at all times.
- 11) MAINTAIN CUTTERS WITH CARE** - Keep cutters sharp and clean for better and safer performance.
- 12) DISCONNECT ROUTER** - When not in use and before changing or adjusting cutters.
- 13) CHECK DAMAGED PARTS** - Always inspect cutters before use for signs of wear or damage. Do not use cracked or broken cutters.
- 14) STAY ALERT** - Use common sense. Do not operate power tools when you are tired or under the influence of drugs, alcohol or medication.
- 15) TAKE EXTRA CARE WHEN SWITCHING** - Watch what you are doing when turning the router on and off. The NVR switch available as an optional item is recommended to avoid the operator having to reach under the table to operate the switch.

## **ASSEMBLY INSTRUCTIONS**

Part numbers are shown in brackets, for example (12)

### **ASSEMBLE THE LEGS**

The two rectangle frames which are the legs of the router table can be mounted in two ways depending on the type of router to be used. Smaller routers can be used with the shorter side of the leg in the vertical position, as shown in Fig.1. For larger routers the longer side of the leg must be in the vertical position to lift the table higher off the work bench, as shown in Fig.2.

If you have purchased the floorstand for this router table the legs should be fitted with the shorter side vertical and with the two holes at the bottom of the leg as shown in the exploded view diagram Fig.15.

Attach the two Legs (2) to the table (1) using four Countersunk screws M8x55mm (6), Washers M8 (8) and Hex nuts M8 (7).

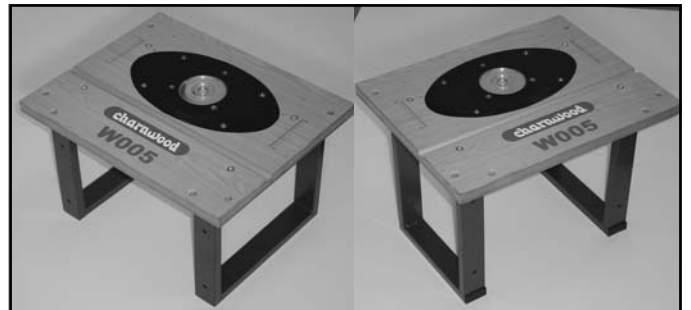
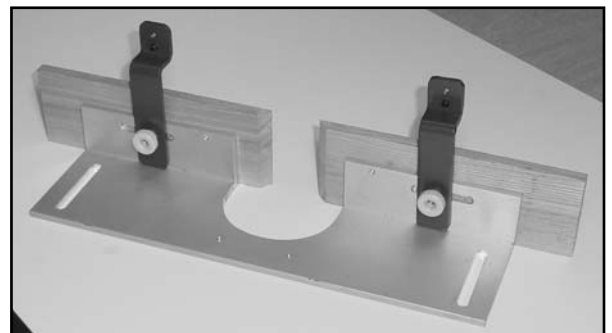

**Fig.1**

### **ASSEMBLE THE FENCE**

i) Locate the Fence base (12), the Vertical supports (14), and Wooden fences (11).

Insert Countersunk screw M6x25mm (25), through the wooden fence, then through the slot in the fence base and then through the vertical clamp support. Secure it with washer M6 (19) and knob female M6 (20).



**Fig.2**

ii) Attach the two vertical clamps (13) to the vertical clamp supports using washer M5 (22) and knob M5x10mm (21).

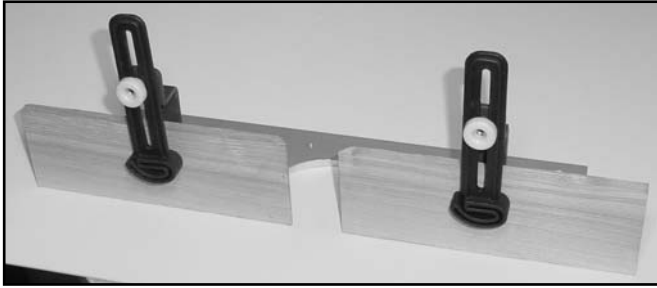

Fig.3

iii) Attach the transparent plastic dust chute (15) using two roundhead screws M5x10mm (23) with Washers M5 (22).

This dust chute is designed to be used with vacuum cleaners, using a 38mm hose, or dust extractors, using either a 50mm hose or 100mm hose with a reducing cone, fitting either inside or over the outside of the chute accordingly. It will sometimes be necessary to obtain a reducing cone to match your hose to the outlet.

If you are intending to use the router table without a dust collector it is better to leave off the dust chute to avoid a build up of wood shavings.



Fig.4

iv) Attach the transparent plastic cutter Guard (10) to the fence using knob M5x10mm (21) and washer M5 (22).



Fig.5

v) Attach the completed fence unit to the table by inserting knob M6x16mm (24) with washer M6 (19) through the slot in the fence base into the threaded insert in the table top.

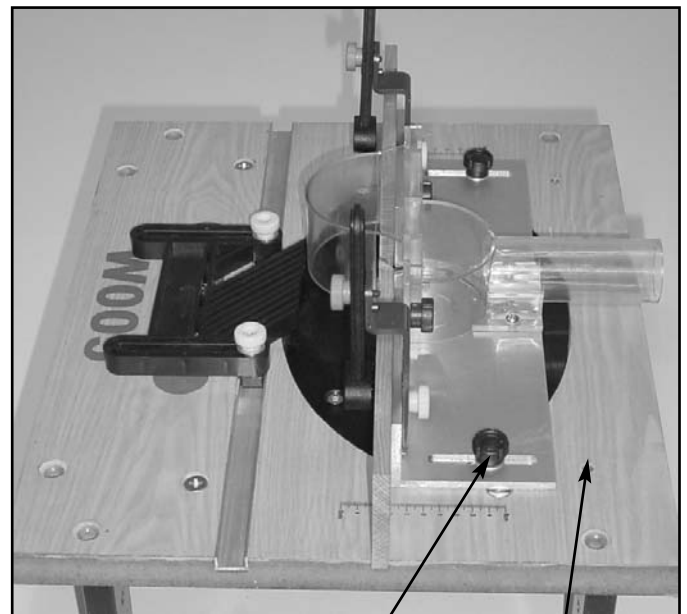

Fig.6

Position 1

Position 2

There are two sets of threaded inserts in the table. The choice of which to use will depend on the type of job to be performed; Position 1 allows the fence to be set at the front of the cutter aperture for making shallow cuts or edge moulding. Position 2 allows the fence to be set further back from the cutter for operations such as trenching.

#### ASSEMBLE THE FINGER PRESSURE

The finger pressure unit is already assembled and simply needs fitting to the table. It locks into the aluminium channel which runs across the front of the table using the two knobs (20).

## **ROUTER MOUNTING INSTRUCTIONS**

i) **MAKE SURE THE ROUTER IS UNPLUGGED.**  
Remove the face plate cover from the router ( If your router does not have a removable face plate cover, measure the spacing of the fixing holes in the face plate and then mark out the insert plate, keeping the cutter aperture as the centre).

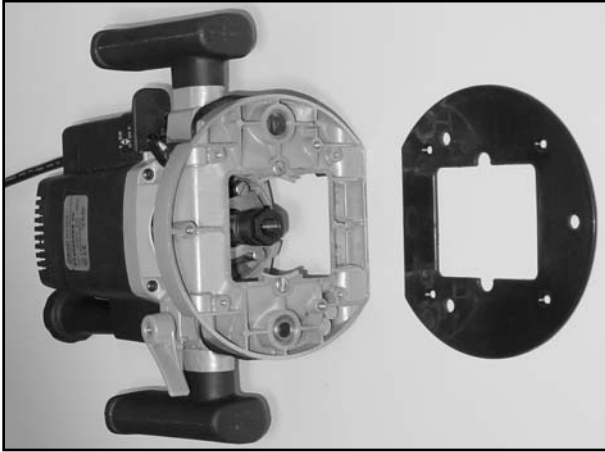

**Fig.7**

ii) Remove the Oval Insert Plate (3) from the Router Table.  
iii) Align the centre of the aperture in the insert plate with the centre of the cut-out in the face plate cover.

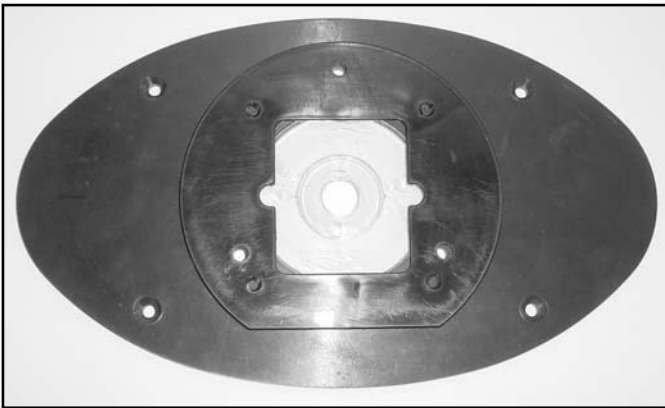

**Fig.8**

Using the face plate cover as a template mark out the fixing holes.

The number and position of the holes will vary with each model of router. Use the larger diameter holes if there is a choice.

A minimum of two fixings must be used, three or four fixings is preferable with heavier routers.

A selection of fixing screws are included in this package which covers most common routers, but we cannot guarantee to cover every available model of router. In some instances it may be necessary to obtain alternative fixing screws.

iv) Drill and countersink the insert plate. Use a drill bit size suitable to the fixing screw you are going to use. If you do not have a countersink tool, drill the fixing hole and then make a countersink by partially drilling through with a larger diameter drill bit. Take care not to drill right through the insert plate.

Normally the mounting holes will be drilled through the black plastic part of the insert plate, however with some smaller routers it is necessary to drill the fixing holes into one of the transparent insert rings (4&5).

v) Leaving the face plate cover off (if removed) attach the insert plate to the router using the fixing screws supplied or alternative screws where required. Ensure the heads of the screws are slightly below the surface of the table. If they are not, it is necessary to drill the countersink slightly deeper.

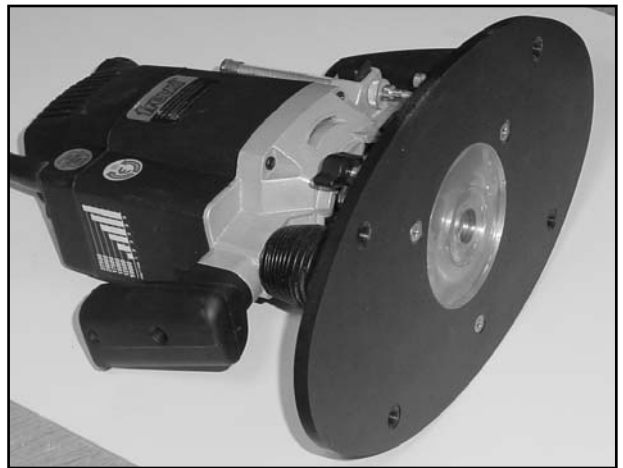
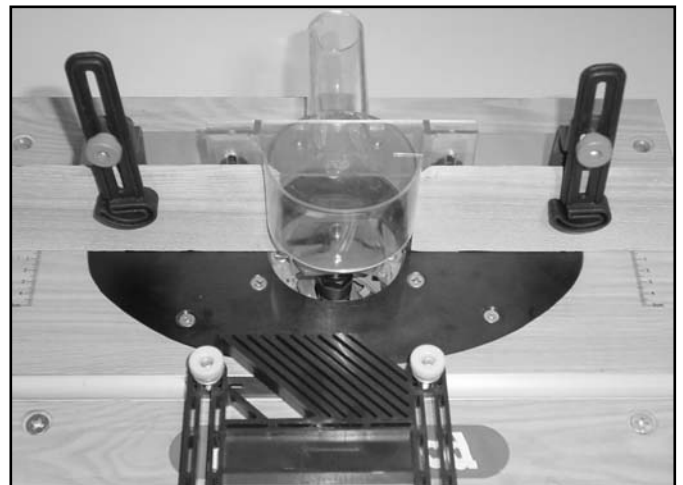

**Fig. 9**

vi) Check that the router is secured tightly to the insert plate and that there is no movement between the two.

vii) Install the desired cutter and set to the correct depth. Fit the router and insert plate into the table, securing with the four M6x16mm countersunk screws (6). Re-fit the fence and finger pressure.

The Router Table is now ready for use.



**Fig. 10**

**PLEASE READ SAFETY INSTRUCTIONS  
BEFORE USE.**

# **BASIC OPERATING INSTRUCTIONS**

## **1) EDGING AND PROFILING**

One of the most common operations undertaken using a router is Edging or Profiling, i.e. running a shaped cutter along the edge of the workpiece. In many instances this is for decorative purposes but it can also be to make a joint or fitting such as a raised panel.

Using a router table for this type of work vastly reduces the setting up time required and does away with many awkward clamping devices. Router table users soon find that having both hands free to control the workpiece, rather than holding a machine, makes the task far more comfortable and generally a lot safer.

**CHOOSE THE INSERT RING:-** The router table is supplied with an insert plate and two transparent insert rings to give a range of cutter apertures. Always choose the smallest possible aperture for safety. For example when working with a cutter of 38mm diameter, use the outer transparent ring which gives an aperture of 42mm.

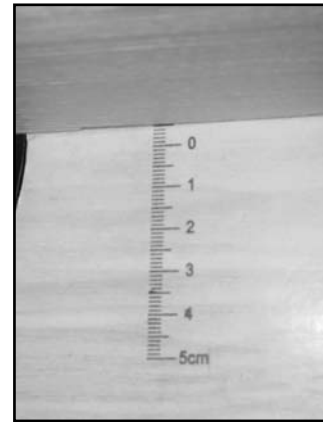

**Fig. 11**

**SET THE CUTTER HEIGHT:-** First fit a suitable cutter after making sure the router is unplugged. It is often easier to do this by unscrewing the insert plate from the table and lifting the router out of the table. Draw a profile of the required cut onto the edge of the workpiece and adjust the cutter height to match. Adjusting the cutter height is made much easier if a fine height adjuster is fitted to the router. With many models this now comes as standard, but on others it is available as an accessory produced by the router manufacturer. Having set the cutter height fit the router back into the table and secure with the four screws.

**SET THE FENCE:-** The next step is to set the fence in a position to give the desired width of cut. Use the profile drawn on the end of the workpiece to set the fence and lock into position. There is a scale printed onto the table to assist in rapid fence setting. When using a cutter fitted with a guide bearing the fence should be set in line or just in front of the edge of the bearing so that the workpiece runs on the face of the bearing. The distance

between the two wooden fence faces can be adjusted by undoing the knobs and sliding the clamp assembly and fence along. The fence faces should be set so that the edges just clear the cutter. This provides the maximum amount of support to the workpiece during the cut.



**Fig. 12**

**SET THE CLAMPS:-** Adjust the Finger Pressure so that the distance between the ends of the fingers and the fence is between 2 to 5mm less than the width of the workpiece. This will hold the workpiece securely against the fence and prevent 'kick-back' during the cut. Next set the left and right Top Clamps. The top clamps are made of flexible plastic and should be set so that the distance between the bottom of the clamp and the surface of the table is between 1 to 3mm less than the thickness of the workpiece. When the clamps are correctly set, the operator merely has to push the workpiece across the table.

Please Note: Some workpieces may be too big to fit inside either the Top Clamps or the Finger Pressure, i.e. larger than 70 x 80mm. Simply remove the clamp/finger pressure from the table. The function of the clamps is twofold; to hold the workpiece securely against the cutter, whilst keeping the hands well away from it. When using larger workpieces the increased weight will help to keep it against the cutter and the danger of hands being too near the cutter is greatly reduced.

**SET THE CUTTER GUARD:-** Adjust the transparent guard so that it just clears the work piece and will deflect any chips or dust which are thrown towards the operator. If possible connect a vacuum cleaner or dust extractor to the dust chute before commencing the cut.

Make a cut with a waste piece of wood before using the workpiece. Mistakes cannot usually be rectified afterwards.

## **THE GOLDEN RULES;**

**ALWAYS KEEP HANDS WELL AWAY FROM THE CUTTER**

**ALWAYS USE A PUSH STICK WITH SMALL WORKPIECES**

**ALWAYS FEED FROM RIGHT TO LEFT ONLY**



Fig. 13

## 2) GROOVING

Grooving and Trenching operations are often carried out to form joints such as slot dovetails or to make fittings such as draw runner grooves.

**SET THE CUTTER HEIGHT:-** Fit the appropriate cutter into the router and set the plunge depth to give the desired cut.

**SET THE FENCE:-** The cut is made away from the edge of the workpiece and therefore it will probably be necessary to move the Fence back into Position 2. Measure the distance between the edge of the workpiece and the start of the groove and lock the fence in position with the two knobs. The two wooden fence faces should be closed up to form one continuous fence which will provide the best support.

**SET THE CLAMPS:-** Set the Finger Pressure and Top Clamps as for edging and profiling. Remove the Top Clamps or Finger Pressure as necessary.

**CUTTER GUARD:-** The cutter guard and dust extraction chute are not used during this operation. Get into the habit of testing all cutter or table adjustments on a waste piece of wood first before commencing on the workpiece.

## 3) USING THE MITRE GUIDE

For some operations it is not possible to use the fence as a guide, for example Trenching at an angle or cutting a Tenon where the width of the workpiece restricts good support from the fence. To do these jobs a sliding mitre guide is used which runs in the aluminium slot across the front of the table.

**REMOVE THE EDGING FENCE:-** Undo the two fixing screws and either remove the fence or adjust it to a position where it will not interfere with the cut.

**FIT THE MITRE FENCE:-** The mitre guide is supplied with a wooden face and a screw to fix it to the quadrant. It should be fitted so that the mitre fence runs right up to the cutter. Do not worry if the cutter actually cuts through part of the mitre fence, it will actually help the cut by reducing break-out on the back edge. You can easily make a new fence for each job.

**SET THE ANGLE:-** To change the angle of the mitre fence, undo the knob and read off the engraved scale on the casting. Tighten the knob at the required angle.

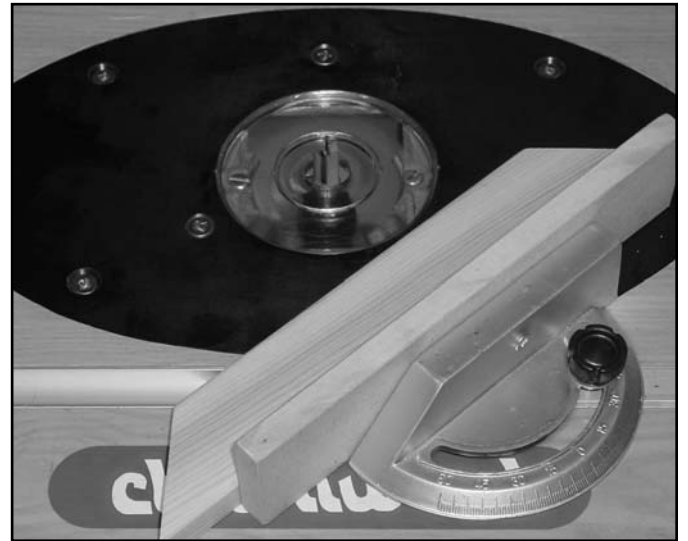

Fig. 14

## 4) CUTTING CURVES

It is possible to put edge moulds on curved workpieces using a router table and a cutter with a bearing guide. Many cutters are now available with a bearing on top which is used as a guide instead of the fence.

Set the cutter height in the normal manner. You cannot take off a whole edge when using a bearing guided cutter. Make sure there is enough of the workpiece edge left uncut for the cutter bearing to run on.

If the whole edge is to be removed or you wish to cut out a profile from a straight edge it is necessary to use a template. Attach the workpiece to the underside of the template so that once the cut is started the bearing will run on the edge of the template whilst the cutter touches only the workpiece.

## Free Manuals Download Website

<http://myh66.com>

<http://usermanuals.us>

<http://www.somanuals.com>

<http://www.4manuals.cc>

<http://www.manual-lib.com>

<http://www.404manual.com>

<http://www.luxmanual.com>

<http://aubethermostatmanual.com>

Golf course search by state

<http://golfingnear.com>

Email search by domain

<http://emailbydomain.com>

Auto manuals search

<http://auto.somanuals.com>

TV manuals search

<http://tv.somanuals.com>