

# INTIMIDATOR™

## WASH ZOOM 250 IRC

### User Manual

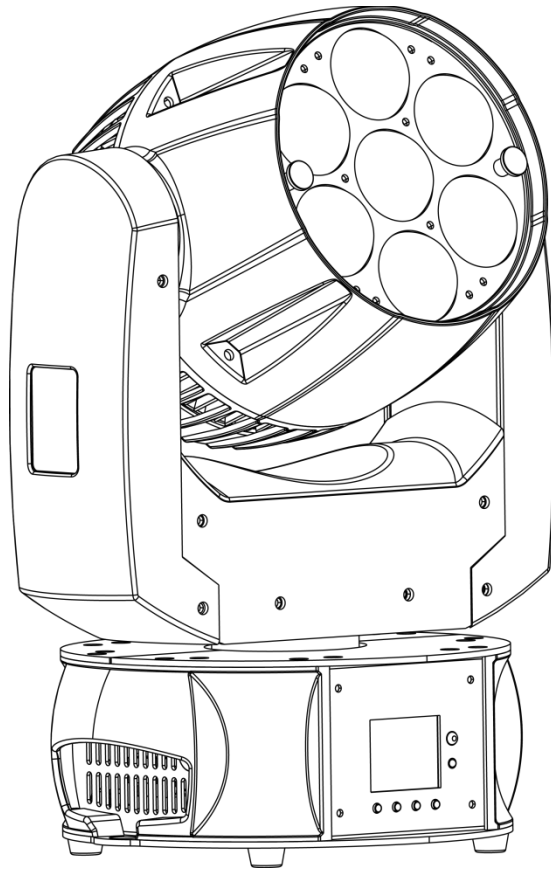

**CHAUVET®**  
It's Green Thinking.™

---

# TABLE OF CONTENTS

<b>1. Before You Begin .....</b>	<b>4</b>
What is Included .....	4
Unpacking Instructions.....	4
Claims .....	4
Text Conventions .....	4
Symbols .....	4
Disclaimer .....	4
Product at a Glance .....	5
Safety Notes .....	5
<b>2. Introduction .....</b>	<b>6</b>
Overview .....	6
Dimensions .....	7
<b>3. Setup .....</b>	<b>8</b>
AC Power.....	8
Fuse Replacement.....	8
Power Linking .....	9
Power Linking Diagram.....	9
Mounting .....	10
Orientation .....	10
Rigging.....	10
Mounting Diagram .....	10
<b>4. Operation .....</b>	<b>11</b>
Manual Zoom Lens .....	11
Control Panel .....	12
Menu Map .....	12
Configuration (DMX) .....	13
DMX Starting Address .....	13
DMX Personalities .....	13
DMX Channel Assignments and Values.....	14
7CH.....	14
14CH.....	16
Configuration (Standalone).....	19
Sound Mode .....	19
Auto Mode .....	19
IR Mode .....	19
IRC-6 Operation.....	20
Configuration (Master/Slave) .....	21
Configuring the Slaves.....	21
Configuring the Master .....	21
Configuration (Settings) .....	22
Pan Reverse .....	22
Tilt Reverse.....	22
Pan Range .....	22
Tilt Range .....	22
Movement Speed.....	23
Fan Operation.....	23
Display ON/OFF .....	23

---

Display Orientation .....	23
Dimming Curve .....	24
Dimming Speed .....	24
Color Balance .....	24
Sensitivity .....	25
Reset.....	25
Reset to Factory Defaults .....	25
System Information .....	25
<b>5. Technical Information .....</b>	<b>26</b>
Product Maintenance .....	26
<b>6. Technical Specifications .....</b>	<b>27</b>
<b>Returns.....</b>	<b>28</b>
General Info .....	28
U.S., UK, Ireland, and Mexico .....	28
Contact Us .....	29

# 1. BEFORE YOU BEGIN

## What is Included

- Intimidator™ Wash Zoom 250 IRC
- Power Cord
- Thread Reducing Adapter
- Warranty Card
- Quick Reference Guide

## Unpacking Instructions

Carefully unpack the product immediately and check that all the parts are in the package and are in good condition.

## Claims



If the box or any of the contents appear damaged from shipping, or show signs of mishandling, save all packaging and file a claim with the carrier immediately, do not notify CHAUVET®. Failure to report damage to the carrier immediately or failure to have all packaging available for inspection may invalidate your claim.

For other issues, such as missing components or parts, damage not related to shipping, or concealed damage, file a claim with CHAUVET® within 7 days of delivery. For information on contacting CHAUVET®, see the [Contact Us](#) section of this manual.

## Text Conventions

Convention	Meaning
1–512	A range of values
50/60	A set of values
Settings	A menu option
Menu > Settings	A sequence of menu options
<ENTER>	A button to be pressed
ON	A value to be entered or selected

## Symbols

Symbol	Meaning
	Critical installation, configuration, or operation information. Not following these instructions can make the product not work, cause damage to the product, or cause harm to the operator.
	Important installation or configuration information. The product might not function correctly if this information is not used.
	Useful information.

## Disclaimer

The information and specifications contained in this User Manual are subject to change without notice. CHAUVET® assumes no responsibility or liability for any errors or omissions, and reserves the right to revise or recreate this manual at any time. The latest version of this manual should be downloaded from <http://www.chauvetlighting.com/product-manuals-literature/>.

© Copyright 2014 CHAUVET®. All rights reserved.

Electronically published by CHAUVET® in the United States of America.

Author	Date	Editor	Date
L. Henry	12/30/13	A. Leon	1/2/14

## Product at a Glance

Use on Dimmer	X	Auto Programs	P
Outdoor Use	X	Auto-ranging Power Supply	P
Sound-Activated	P	Replaceable Fuse	P
DMX	P	User-Serviceable	X
Master/Slave	P		

## Safety Notes

These notes include important information about the mounting, use, and maintenance of this product. Read these notes before using the product.



- Always connect the product to a grounded circuit to avoid the risk of electrocution.
- Make sure the power cord is not crimped or damaged.
- Always disconnect the product from the power source before cleaning it or replacing the fuse.
- Never disconnect the product from the power source by pulling or tugging on the cord.
- If mounting the product overhead, always secure it using a safety cable.
- Make sure there are no flammable materials close to the product when it is operating.
- Avoid direct eye exposure to the light source while the product is on.
- Do not touch the product's housing when the product is operating because the housing can be very hot.



- This product is not intended for permanent installation.
- The product is for indoor use only! It is rated at IP20.
- To prevent risk of fire or shock, do not expose the product to rain or moisture.
- Always make sure that the voltage of the power source to which the product is connected is within the range stated on the sticker or rear panel of the product.
- Never connect the product to a dimmer or rheostat.
- Make sure to replace the fuse with another of the same type and rating.
- Always install the product in a location with adequate ventilation, and leave at least 20 in (50 cm) between the product and adjacent surfaces.
- Always use the handles to carry this product.
- The maximum ambient temperature ( $T_a$ ) in which the product can be used is 104 °F (40 °C). Do not operate the product at higher temperatures.
- Be sure that no ventilation slots on the product's housing are blocked.
- Never carry the product by the power cord or any moving part.
- In the event of a serious operating problem, stop using the product immediately.
- Never try to repair the product. Repairs carried out by unskilled people can lead to damage or malfunction. Contact the nearest authorized technical assistance center.



Keep this User Manual for future reference. If you sell the product to another user, be sure to give this manual to the next owner.

---

## 2. INTRODUCTION

### Overview

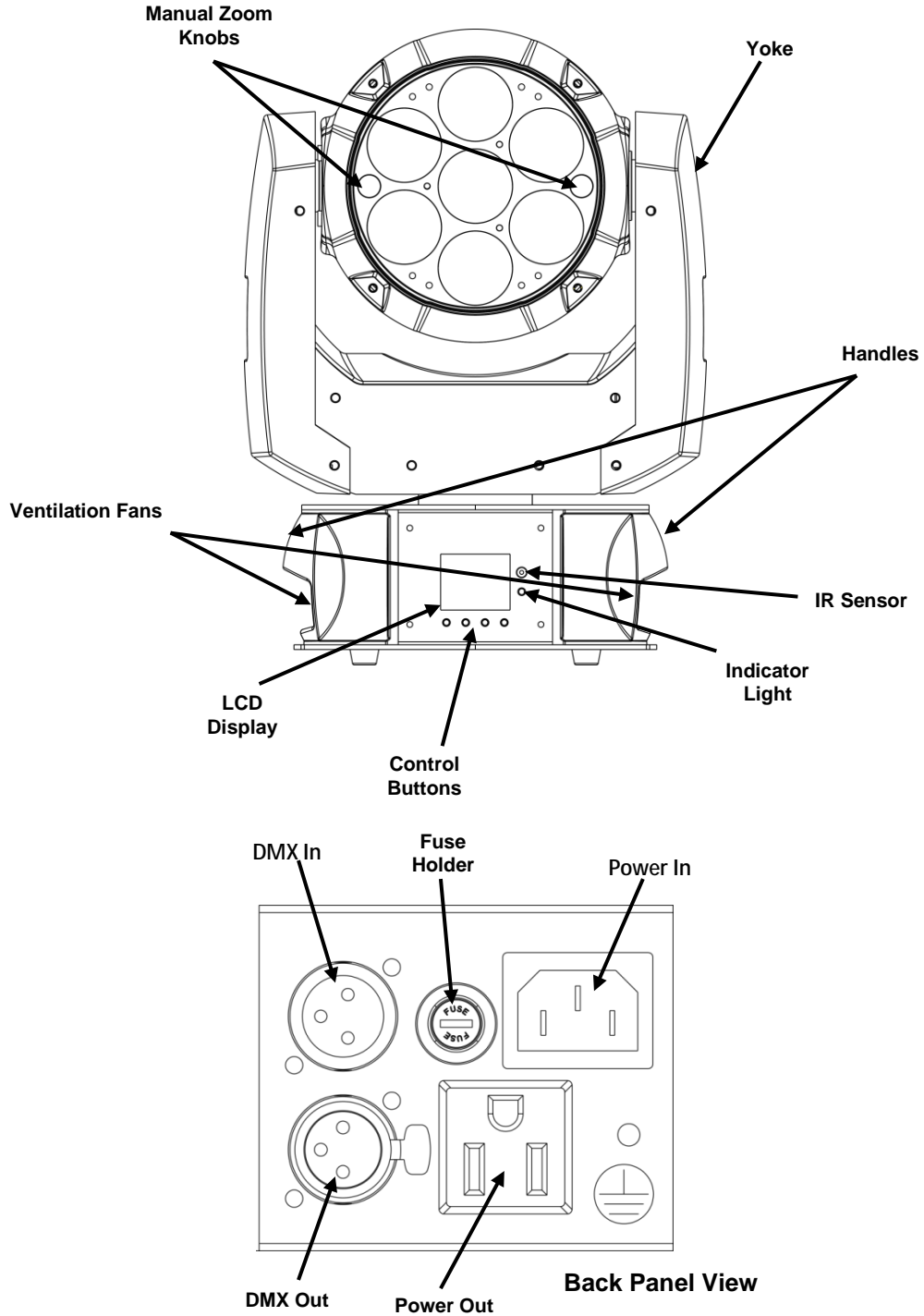

# Dimensions

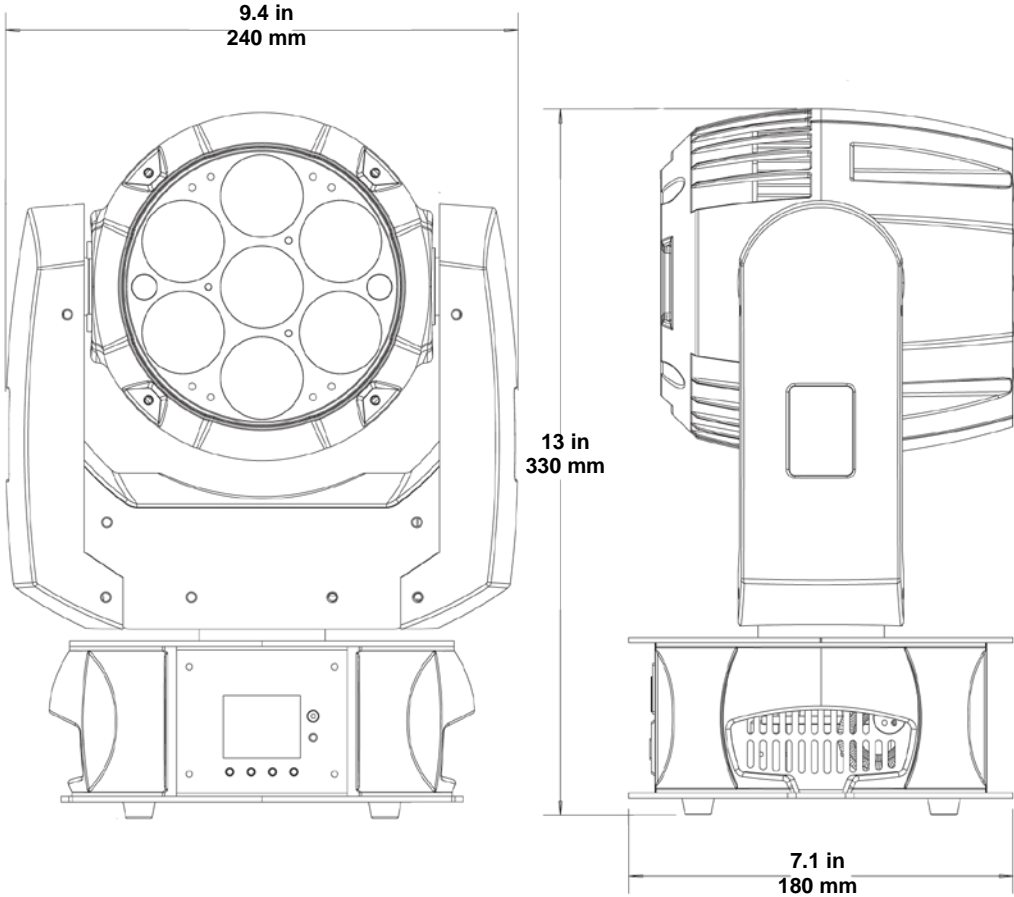

---

## 3. SETUP

### AC Power

The Intimidator™ Wash Zoom 250 IRC has an auto-ranging power supply that works with an input voltage range of 100 to 240 VAC, 50/60 Hz.

To determine the product's power requirements (circuit breaker, power outlet, and wiring), use the values listed on the label affixed to the product's back panel, or refer to the product's Specifications. The listed current rating indicates the product's average current draw under normal conditions.

The Intimidator™ Wash Zoom 250 IRC can be power linked via the IEC and Edison outlets in its base.



**Always connect the product to a protected circuit (circuit breaker or fuse). Make sure circuit has an appropriate electrical ground to avoid the risk of electrocution or fire.**

**Never connect the product to a rheostat (variable resistor) or dimmer, even if the rheostat or dimmer serves only as a 0 to 100% switch.**

### Fuse Replacement

1. Make sure product is not connected to a power source.
2. Place the tip of a flat-head screwdriver into the slot in the fuse holder.
3. Turn the screwdriver counterclockwise and the fuse holder will come loose.
4. Pull the fuse holder out of the product.
5. Pull the blown fuse out of the fuse holder.
6. Place a new fuse of the exact same type and rating into the fuse holder.
7. Insert the fuse holder into the product.
8. Place the tip of a flat-head screwdriver into the slot in the fuse holder.
9. Turn the screwdriver clockwise and the fuse holder will tighten into place.



**Disconnect the product from power before replacing the fuse.**

**Use only the fuse listed in the Technical Specifications section or on the specifications sticker on the product.**

**A spare fuse is not included.**



## Power Linking

The product provides power linking via the Edison/IEC outlet located in the back of the unit.

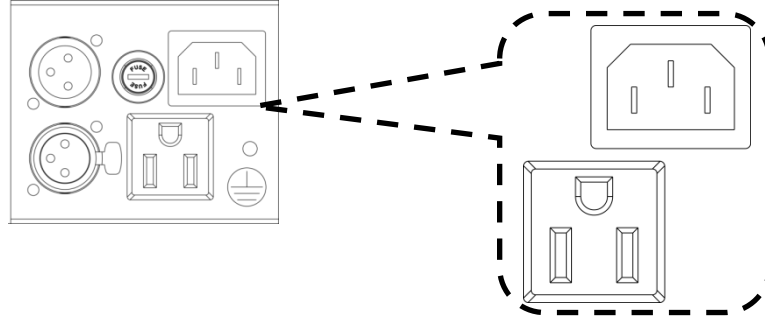

## Power Linking Diagram

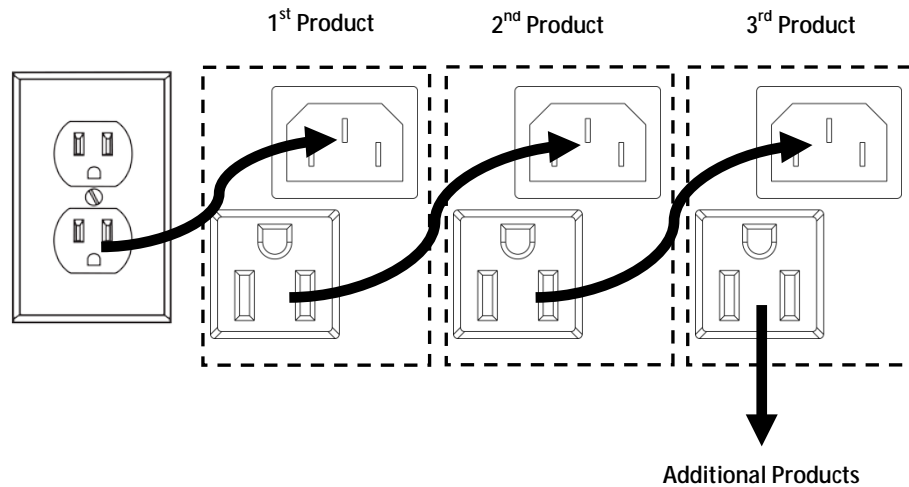

You can power link up to 5 Intimidator™ Wash Zoom 250 IRC units on 120 V or up to 9 Intimidator™ Wash Zoom 250 IRC units on 230 V.



The power linking diagram shown above corresponds to the North American version of the product ONLY! If using the product in other markets, you must consult with the local CHAUVET® distributor as power linking connectors and requirements may differ in your country or region

## Mounting

Before mounting the product, read and follow the safety recommendations in the [Safety Notes](#) section.

## Orientation

The Intimidator™ Wash Zoom 250 IRC can be mounted in any position, but make sure the placement allows adequate ventilation for the product, and allows for movement of the yoke and head in any direction.

## Rigging

Be sure to place the product in a location that allows easy access to it for maintenance and programming, and enough space around the product for ventilation.

Make sure that the structure or surface onto which the product will be mounted can support the product's weight. For more information see the [Technical Specifications](#) section.

When mounting the product overhead, always use a safety cable and make sure the product is attached securely.

When mounting the product on a truss or pipe, use a mounting clamp with the appropriate weight capacity. CHAUVET® has a full range of mounting clamps. See <http://www.chauvetlighting.com/cables-clamps-main.html> for the complete selection.

The rubber feet serve as floor supports. When placing the product on the floor, make sure that the product and cables are away from people and vehicles.

## Mounting Diagram

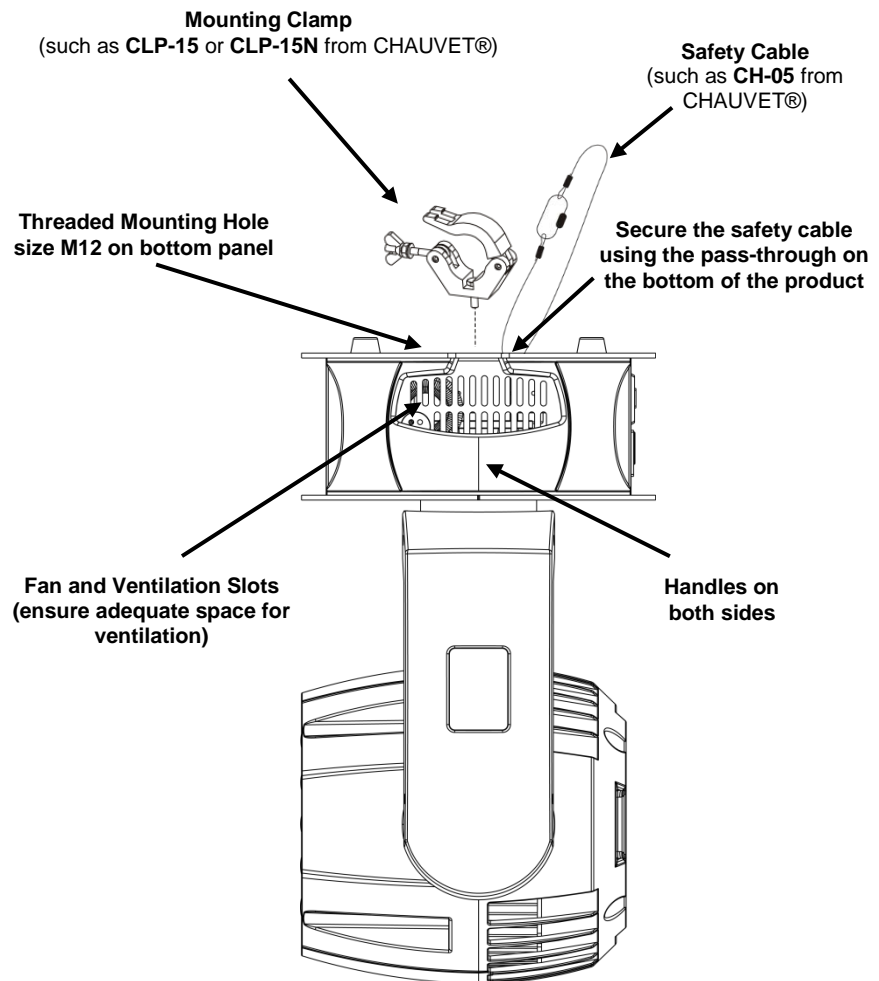

---

## 4. OPERATION

### Manual Zoom Lens

The manual zoom lens sets the size of the light beam in a range from 14° to 58°. Moving the zoom lens deeper into the product makes the light beam wider. The lens can be adjusted when the product is turned off or when it is turned on and emitting light, but do not adjust the zoom lens while it is moving.

To adjust the manual zoom lens, do the following:

1. Make sure the product is not moving.
2. Grab the two manual zoom knobs gently.
3. Slide the lens back and forth to achieve the desired beam size.



**The product can be made to be stationary and emit light by using DMX controls. For more information, see the [Configuration DMX](#).**

## Control Panel

The control panel is used to set the operating mode, and the configuration settings of the product. Use the 4 buttons underneath the LCD display to access the control panel and navigate the menu map. For specific instructions see the Configurations sections below.

Button	Function
<MENU>	Enters into, or backs out of, the current menu option
<UP>	Scrolls up the list of options or selects a higher value
<DOWN>	Scrolls down the list of options or selects a lower value
<ENTER>	Activates a selected menu or value

## Menu Map

Menu	Value	Description	
<b>Address</b>	<b>001–512</b>	Sets the DMX starting address	
<b>Run Mode</b>	<b>DMX</b>	<b>14CH</b> <b>7CH</b>	Sets DMX personality
	<b>Auto</b>	<b>Auto01—Auto16</b>	Sets Auto mode
		<b>Sound</b>	Sets Sound mode
		<b>Slave</b>	Sets Slave mode
		<b>IR</b>	Sets infrared control
<b>Setup</b>	<b>Pan Reverse</b>	<b>OFF</b> <b>ON</b>	Normal pan operation Reverse pan operation
	<b>Tilt Reverse</b>	<b>OFF</b> <b>ON</b>	Normal tilt operation Reverse tilt operation
	<b>Pan Angle</b>	<b>540</b>	Sets the 540° pan angle range
		<b>360</b>	Sets the 360° pan angle range
		<b>180</b>	Sets the 180° pan angle range
	<b>Tilt Angle</b>	<b>270</b>	Sets the 270° tilt angle range
		<b>180</b>	Sets the 180° tilt angle range
		<b>90</b>	Sets the 90° tilt angle range
	<b>P/T Speed</b>	<b>Normal</b>	Sets the panning/tilting speed
		<b>Fast</b>	
		<b>Slow</b>	
	<b>Fans</b>	<b>Auto</b>	Sets fan speed to be triggered according to temperature
		<b>Full</b>	Sets fan speed to full
	<b>Display</b>	<b>OFF</b>	Display turns off after inactivity
		<b>ON</b>	Display stays on after inactivity
	<b>Screen Rev</b>	<b>OFF</b>	Normal display
		<b>ON</b>	Upside-down display
	<b>Dimmer Curve</b>	<b>Square</b>	Sets the dimmer curve mode
		<b>I Squa</b>	
		<b>SCurve</b>	
<b>Linear</b>			
<b>Dimmer Speed</b>	<b>Fast</b>	Sets the dimmer speed	
	<b>Smooth</b>		
<b>Color Balance</b>	<b>RED</b>	Sets color balance ( <b>100–255</b> )	
	<b>GREEN</b>		
	<b>BLUE</b>		
	<b>WHITE</b>		
<b>Sensitivity</b>	<b>001—100</b>	Sets sound sensitivity	
	<b>Reset</b>	Resets the product	
	<b>Factory Set</b>	Loads factory defaults	
<b>Sys Info</b>	<b>Ver</b> <b>Running Mode</b> <b>DMX Address</b> <b>Temperature</b>	Shows the current software version, running mode, DMX address and product's temperature	

---

## Configuration (DMX)

To set the product in DMX mode for control with a DMX controller, do the following:

1. Make sure the product is plugged into a power source.
2. Connect the male end of a DMX cable to the DMX output socket of the DMX controller and the female end of the same cable to the DMX input socket on the product.

Set the DMX starting address and personality by following the directions below.

### DMX Starting Address

When selecting a starting DMX address, always consider the number of DMX channels needed for the selected DMX personality. Choosing a starting address that is too high can restrict access to some of the product's channels.

The Intimidator™ Wash Zoom 250 IRC uses either 7 or 14 channels, depending on the personality. The highest configurable DMX address in 7-channel mode is **506**. The highest configurable DMX address in 14-channel mode is **499**.

For more information about DMX download the CHAUVET® DMX Primer from the CHAUVET® web site <http://www.chauvetlighting.com/download>.

To set the DMX starting address, do the following:

1. If the display shows a number from 001–512, go to step 5.
2. Press **<MENU>** repeatedly until 4 icons show on the display.
3. Use **<UP>** and **<DOWN>** to highlight **Address**.
4. Press **<ENTER>**. A number from 001–512 will show on the display.
5. Use **<UP>** or **<DOWN>** to change the number to the desired DMX starting address.
6. Press **<ENTER>** to select the DMX starting address.

### DMX Personalities

The Intimidator™ Wash Zoom 250 IRC has 2 DMX personalities: a 7-channel personality and a 14-channel personality.

To set the DMX personality, do the following:

1. Press **<MENU>** repeatedly until 4 icons show on the display.
2. Use **<UP>** and **<DOWN>** to highlight the **Run Mode** icon.
3. Press **<ENTER>**. The **Run Mode** options will show on the display.
4. Use **<UP>** and **<DOWN>** to highlight **DMX**.
5. Press **<ENTER>**. A green dot will show on the **DMX** option line and the characters **7CH** or **14CH** will show in green.
6. Use **<UP>** or **<DOWN>** to switch between **7CH** and **14CH**.
7. Press **<ENTER>** to select the DMX personality shown.



**After the DMX starting address and personality have been set, there will be a delay of 30 seconds before the display automatically returns to showing the current DMX address and the DMX personality.**

**If the display goes blank after 30 seconds, it is because the Display option is set to OFF. To set the Display option to ON go to Menu > Setup > Display and change the value to ON. For more information see the [Display ON/OFF](#).**

## DMX Channel Assignments and Values

7CH	Channel	Function	Value	Percent/Setting
	1	Pan	000 ◊ 255	0 to 540°
	2	Tilt	000 ◊ 255	0 to 270°
	3	Speed	000 ◊ 255	Pan/Tilt (fast to slow)
			000 ◊ 004	No function
			005 ◊ 009	Color 1
			010 ◊ 014	Color 2
			015 ◊ 019	Color 3
			020 ◊ 024	Color 4
			025 ◊ 029	Color 5
			030 ◊ 034	Color 6
			035 ◊ 039	Color 7
			040 ◊ 044	Color 8
			045 ◊ 049	Color 9
			050 ◊ 054	Color 10
			055 ◊ 059	Color 11
			060 ◊ 064	Color 12
			065 ◊ 069	Color 13
			070 ◊ 074	Color 14
			075 ◊ 079	Color 15
			080 ◊ 084	Color 16
			085 ◊ 089	Color 17
			090 ◊ 094	Color 18
			095 ◊ 099	Color 19
			100 ◊ 104	Color 20
	4	Colors	105 ◊ 109	Color 21
			110 ◊ 114	Color 22
			115 ◊ 119	Color 23
			120 ◊ 124	Color 24
			125 ◊ 129	Color 25
			130 ◊ 134	Color 26
			135 ◊ 139	Color 27
			140 ◊ 144	Color 28
			145 ◊ 149	Color 29
			150 ◊ 154	Color 30
			155 ◊ 159	Color 31
			160 ◊ 164	Color 32
			165 ◊ 169	Color 33
			170 ◊ 174	Color 34
			175 ◊ 179	No function
			180 ◊ 201	Clockwise color change (fast to slow)
			202 ◊ 207	Stop (color stays in the current color)
			208 ◊ 229	Counter-clockwise color change (slow to fast)
			230 ◊ 234	No function
			235 ◊ 249	Color jump (fast to slow)
			250 ◊ 255	Sound colors

7CH (cont.)	Channel	Function	Value	Percent/Setting
	5	Dimmer	000 ◊ 255	0 to 100%
	6	Shutter	000 ◊ 019	Closed
			020 ◊ 024	Open
			025 ◊ 064	Strobe effect (decreasing speed)
			065 ◊ 069	Open
			070 ◊ 084	Fast on, slow off (decreasing speed)
			085 ◊ 089	Open
			090 ◊ 104	Slow on, fast off (decreasing speed)
			105 ◊ 109	Open
			110 ◊ 124	Random shutter (decreasing speed)
			125 ◊ 129	Open
			130 ◊ 144	Random fast on, slow off (decreasing speed)
			145 ◊ 149	Open
			150 ◊ 164	Random slow on, fast off (decreasing speed)
			165 ◊ 169	Open
			170 ◊ 184	Pulse effect 1 (decreasing speed)
			185 ◊ 189	Open
			190 ◊ 204	Pulse effect 2 (decreasing speed)
			205 ◊ 209	Open
			210 ◊ 224	Gradually on and off (decreasing speed)
	225 ◊ 229	Open		
	230 ◊ 244	Pulse effect 3 (decreasing speed)		
	245 ◊ 255	Open		
	7	Movement Macros	000 ◊ 007	No function
			008 ◊ 023	Auto movement macro 1
			024 ◊ 039	Auto movement macro 2
			040 ◊ 055	Auto movement macro 3
			056 ◊ 071	Auto movement macro 4
			072 ◊ 087	Auto movement macro 5
			088 ◊ 103	Auto movement macro 6
			104 ◊ 119	Auto movement macro 7
			120 ◊ 135	Auto movement macro 8
			136 ◊ 151	Sound movement macro 1
			152 ◊ 167	Sound movement macro 2
			168 ◊ 183	Sound movement macro 3
			184 ◊ 199	Sound movement macro 4
			200 ◊ 215	Sound movement macro 5
			216 ◊ 231	Sound movement macro 6
			232 ◊ 247	Sound movement macro 7
	248 ◊ 255	Sound movement macro 8		

14CH	Channel	Function	Value	Percent/Setting
	1	Pan	000 ◊ 255	0 to 540°
	2	Fine Pan	000 ◊ 255	Fine control of panning
	3	Tilt	000 ◊ 255	0 to 270°
	4	Fine Tilt	000 ◊ 255	Fine control of tilting
	5	Speed	000 ◊ 255	Pant/Tilt speed (fast to slow)
	6	Red	000 ◊ 255	0 to 100%
	7	Green	000 ◊ 255	0 to 100%
	8	Blue	000 ◊ 255	0 to 100%
	9	White	000 ◊ 255	0 to 100%
			000 ◊ 004	No function
			005 ◊ 009	Color 1
			010 ◊ 014	Color 2
			015 ◊ 019	Color 3
			020 ◊ 024	Color 4
			025 ◊ 029	Color 5
			030 ◊ 034	Color 6
			035 ◊ 039	Color 7
			040 ◊ 044	Color 8
			045 ◊ 049	Color 9
			050 ◊ 054	Color 10
			055 ◊ 059	Color 11
			060 ◊ 064	Color 12
			065 ◊ 069	Color 13
			070 ◊ 074	Color 14
			075 ◊ 079	Color 15
			080 ◊ 084	Color 16
			085 ◊ 089	Color 17
			090 ◊ 094	Color 18
			095 ◊ 099	Color 19
	10	Colors	100 ◊ 104	Color 20
			105 ◊ 109	Color 21
			110 ◊ 114	Color 22
			115 ◊ 119	Color 23
			120 ◊ 124	Color 24
			125 ◊ 129	Color 25
			130 ◊ 134	Color 26
			135 ◊ 139	Color 27
			140 ◊ 144	Color 28
			145 ◊ 149	Color 29
			150 ◊ 154	Color 30
			155 ◊ 159	Color 31
			160 ◊ 164	Color 32
			165 ◊ 169	Color 33
			170 ◊ 174	Color 34
			175 ◊ 179	No function
			180 ◊ 201	Clockwise color change (fast to slow)
			202 ◊ 207	Stop (color stays in the current color)
			208 ◊ 229	Counter-clockwise color change (slow to fast)
			230 ◊ 234	No function
			235 ◊ 249	Color jump (fast to slow)
			250 ◊ 255	Sound colors



<b>14CH (cont.)</b>		<b>Channel</b>	<b>Function</b>	<b>Value</b>	<b>Percent/Setting</b>
	<b>11</b>	<b>Dimmer</b>		<b>000 ó 255</b>	0 to 100%
	<b>12</b>	<b>Shutter</b>		<b>000 ó 019</b>	Closed
				<b>020 ó 024</b>	Open
				<b>025 ó 064</b>	Strobe effect (decreasing speed)
				<b>065 ó 069</b>	Open
				<b>070 ó 084</b>	Fast on, slow off (decreasing speed)
				<b>085 ó 089</b>	Open
				<b>090 ó 104</b>	Slow on, fast off (decreasing speed)
				<b>105 ó 109</b>	Open
				<b>110 ó 124</b>	Random shutter (decreasing speed)
				<b>125 ó 129</b>	Open
				<b>130 ó 144</b>	Random fast on, slow off (decreasing speed)
				<b>145 ó 149</b>	Open
				<b>150 ó 164</b>	Random slow on, fast off (decreasing speed)
				<b>165 ó 169</b>	Open
				<b>170 ó 184</b>	Pulse effect 1 (decreasing speed)
				<b>185 ó 189</b>	Open
				<b>190 ó 204</b>	Pulse effect 2 (decreasing speed)
				<b>205 ó 209</b>	Open
		<b>210 ó 224</b>	Gradually on and off (decreasing speed)		
		<b>225 ó 229</b>	Open		
		<b>230 ó 244</b>	Pulse effect 3 (decreasing speed)		
		<b>245 ó 255</b>	Open		
	<b>13</b>	<b>Control Functions</b>		<b>000 ó 009</b>	No function
				<b>010 ó 014</b>	Blackout while panning/tilting
				<b>015 ó 049</b>	No function
				<b>050 ó 054</b>	Reset pan
				<b>055 ó 059</b>	Reset tilt
				<b>060 ó 069</b>	No function
				<b>070 ó 074</b>	Reset all
				<b>075 ó 079</b>	No function
				<b>080 ó 084</b>	Reverse pan/tilt
				<b>085 ó 089</b>	Reverse pan
				<b>090 ó 094</b>	Reverse tilt
				<b>095 ó 099</b>	Cancel reverse pan
				<b>100 ó 104</b>	Cancel reverse tilt
				<b>105 ó 109</b>	Cancel reverse pan/tilt
				<b>110 ó 114</b>	Pan/Tilt normal speed
				<b>115 ó 119</b>	Pan/Tilt fast speed
				<b>120 ó 124</b>	Pan/Tilt slow speed
				<b>125 ó 129</b>	Fan (full speed)
		<b>130 ó 134</b>	Fan (auto)		
		<b>135 ó 139</b>	Dimmer, fast		
		<b>140 ó 144</b>	Dimmer, smooth		
		<b>145 ó 255</b>	No function		

14CH (cont.)	Channel	Function	Value	Percent/Setting
	14	Movement Macros	000 ∅ 007	No function
			008 ∅ 023	Auto movement macro 1
			024 ∅ 039	Auto movement macro 2
			040 ∅ 055	Auto movement macro 3
			056 ∅ 071	Auto movement macro 4
			072 ∅ 087	Auto movement macro 5
			088 ∅ 103	Auto movement macro 6
			104 ∅ 119	Auto movement macro 7
			120 ∅ 135	Auto movement macro 8
			136 ∅ 151	Sound movement macro 1
			152 ∅ 167	Sound movement macro 2
			168 ∅ 183	Sound movement macro 3
			184 ∅ 199	Sound movement macro 4
			200 ∅ 215	Sound movement macro 5
			216 ∅ 231	Sound movement macro 6
			232 ∅ 247	Sound movement macro 7
	248 ∅ 255	Sound movement macro 8		

---

## Configuration (Standalone)

Use standalone configurations to operate the product without a DMX controller.



**Never connect a product operating in a standalone mode (Sound, Auto, or IR) to a DMX chain that includes a DMX controller. Products in standalone mode can transmit DMX signals that interfere with the DMX signals from the controller**

### Sound Mode

Sound mode sets the product to respond to sounds and music.

To set the product to Sound mode, do the following:

1. Make sure the product is connected to a power source and not connected to a DMX controller.
2. Press **<MENU>** repeatedly until 4 icons show on the display.
3. Use **<UP>** and **<DOWN>** to highlight the **Run Mode** icon.
4. Press **<ENTER>**. The **Run Mode** options will show on the display.
5. Use the **<UP>** and **<DOWN>** buttons to highlight the **Sound** option.
6. Press **<ENTER>**. A green dot will show on the **Sound** option line and the product will begin reacting to sound.



**The product will respond only to low frequencies of music (bass and drums).**

**If the product is not responding to sound, increase the sensitivity. For more information see the [Sensitivity Setting](#) below.**

### Auto Mode

Auto mode sets the product to 1 of 16 preset movement patterns and color changes.

To set the product to Auto mode, do the following:

1. Make sure the product is connected to a power source and not connected to a DMX controller.
2. Press **<MENU>** repeatedly until 4 icons show on the display.
3. Use **<UP>** and **<DOWN>** to highlight the **Run Mode** icon.
4. Press **<ENTER>**. The **Run Mode** options will show on the display.
5. Use **<UP>** and **<DOWN>** to highlight the **Auto** option.
6. Press **<ENTER>**. A green dot will show on the **Auto** option line, the current Auto mode will show up in green letters, and the product will begin moving and emitting light.
7. Use **<UP>** and **<DOWN>** to cycle through the 16 Auto modes.
8. Press **<ENTER>>** to select one of the 16 Auto modes.

### IR Mode

IR mode allows the product to be controlled with an infrared remote controller. The IRC-6 can remotely set the product to various modes; adjust the color, speed and sensitivity; and set the strobe.

To set the product to IR mode, do the following:

1. Make sure the product is plugged into a power source and not connected to a DMX cable.
2. Press **<MENU>** repeatedly until 4 icons show on the display.
3. Use the **<UP>** and **<DOWN>** to highlight the **Run Mode** icon.
4. Press **<ENTER>**. The **Run Mode** options will show on the display.
5. Use the **<UP>** and **<DOWN>** buttons to highlight the **IR** option.
6. Press **<ENTER>**. A green dot will show on the **IR** option line and the product will begin moving and emitting light.

## IRC-6 Operation

Be sure the IRC-6 remote is pointing directly at the product and there is nothing in between the remote and the product.



Some of the buttons on the remote work differently than what is indicated on their labels. For example:

- **<MANUAL>** controls the white color in the LEDs.
- **<A>**, **<UV>**, and **<W>** control the Blackout function.

Please read the next section carefully.

The list below describes which features each button controls.

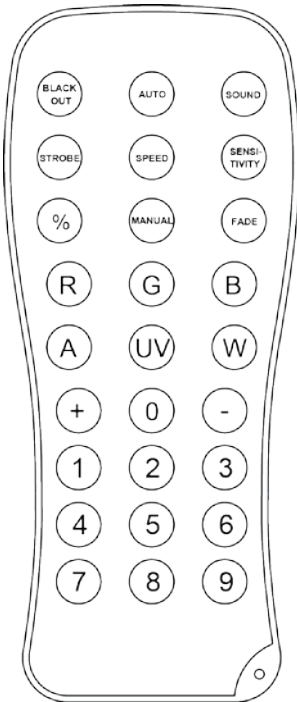

- **<BLACKOUT>** - Turns LEDs on and off.
- **<AUTO>** - Activates Auto mode. Use the **<+>** and **<->** buttons to cycle through Auto modes.
- **<SOUND>** - Activates Sound mode.
- **<STROBE>** - Activates the strobe. Use the **<+>** and **<->** buttons to cycle through strobe speeds.
- **<SPEED>** - Adjusts the movement speed. Use the **<+>** and **<->** buttons to cycle through movement speeds.
- **<SENSITIVITY>** - Adjusts sound sensitivity. Use the **<+>** and **<->** buttons to cycle through sound sensitivity levels.
- **<%>** - Adjusts the brightness of the LEDs. Use the **<+>** and **<->** buttons to increase or decrease the brightness of the LEDs.
- **<MANUAL>** - Adjusts the white color in the LEDs. Use the **<+>** and **<->** buttons to increase or decrease the white color in the LEDs.
- **<FADE/SNAP>** or **<FADE>** - Adjusts the speed and type of color fades. Press the button to switch between fade and snap color changes. Use **<+>** and **<->** to increase or decrease the speed of the color changes.
- **<R>** - Adjusts the red color in the LEDs. Use the **<+>** and **<->** buttons to increase or decrease the red color in the LEDs.
- **<G>** - Adjusts the green color in the LEDs. Use the **<+>** and **<->** buttons to increase or decrease the green color in the LEDs.
- **<B>** - Adjusts the blue color in the LEDs. Use the **<+>** and **<->** buttons to increase or decrease the blue color in the LEDs.
- **<+>** - Increases values for controls as described above.
- **<->** - Decreases values for controls as described above.
- **<0>**-**<9>** - Activates specific Auto modes. Can be used as a shortcut for the combination of the **<AUTO>** button and the **<+>** and **<->** buttons.

---

## Configuration (Master/Slave)

Master/Slave mode allows a single Intimidator™ Wash Zoom 250 IRC (the master) to control the actions of one or more Intimidator™ Wash Zoom 250 IRCs (the slaves) without a DMX controller.

In Master/Slave mode the master is set to operate in Auto mode, Sound mode, or IR mode and the slaves are set to operate in Slave mode.

The master and slaves are daisy chained though the DMX input and output ports with the master at the beginning of the chain. Once set and connected, the slaves will operate identically to, and in unison with, the master.

**Always put the male DMX connector into the master. Do not connect to the DMX In port on the master.**



**Never connect more than 31 slaves to the master.**

**Never connect a DMX controller to a DMX daisy chain of master and slaves.**

**Configure all the slaves before connecting the master to the DMX daisy chain.**

### Configuring the Slaves

Configure the slaves for Slave mode before or after they are put in position, and before they are daisy chained to the master.

To configure a slave, do the following:

1. Make sure the product is connected to a power source.
2. Press **<MENU>** repeatedly until 4 icons show on the display.
3. Use **<UP>** and **<DOWN>** to highlight the **Run Mode** icon.
4. Press **<ENTER>**. The **Run Mode** options will show on the display.
5. Use **<UP>** and **<DOWN>** to highlight the **Slave** option.
6. Press **<ENTER>**. A green dot will show on the **Slave** option line.

### Configuring the Master

Configure the master after all the slaves are connected to it and configured.

To configure the master, do the following:

1. Make sure the product is connected to a power source and connected to all the slaves.
2. Press **<MENU>** repeatedly until 4 icons show on the display.
3. Use **<UP>** and **<DOWN>** to highlight the **Run Mode** icon.
4. Select any of the Standalone modes as described in [Configuration \(Standalone\)](#).

---

## Configuration (Settings)

The Intimidator™ Wash Zoom 250 IRC can be customized with settings such as for movement, speed, display, and fan operation. Below are instructions for all the settings available in the [Setup](#) menu.

### Pan Reverse

Reversing the pan movement is useful when 2 lights are facing each other and they both need to turn toward the same direction.

To reverse the pan movement do the following:

1. Press **<MENU>** repeatedly until 4 icons show on the display.
2. Use **<UP>** and **<DOWN>** to highlight the **Setup** icon.
3. Press **<ENTER>**. The **Setup** options will show on the display.
4. Use **<UP>** and **<DOWN>** to highlight the **Pan Reverse** option.
5. Press **<ENTER>**. The words **ON** or **OFF** will show in green.
6. Use **<UP>** or **<DOWN>** to switch between **ON** and **OFF**.
7. Press **<ENTER>** to select the setting.

### Tilt Reverse

Reversing the tilt movement is useful when 2 lights are facing each other and they need to point towards the same space between them.

To reverse the tilt movement do the following:

1. Press **<MENU>** repeatedly until 4 icons show on the display.
2. Use **<UP>** and **<DOWN>** to highlight the **Setup** icon.
3. Press **<ENTER>**. The **Setup** options will show on the display.
4. Use **<UP>** and **<DOWN>** to highlight the **Tilt Reverse** option.
5. Press **<ENTER>**. The words **ON** or **OFF** will show in green.
6. Use **<UP>** or **<DOWN>** to switch between **ON** and **OFF**.
7. Press **<ENTER>** to select the setting.

### Pan Range

Setting the pan angle range is useful when there is an area of the room that the Intimidator™ Wash Zoom 250 IRC should not illuminate.

To set the range of the Pan movement, do the following:

1. Press **<MENU>** repeatedly until 4 icons show on the display.
2. Use the **<UP>** and **<DOWN>** buttons to highlight the **Setup** icon.
3. Press **<ENTER>**. The **Setup** options will show on the display.
4. Use the **<UP>** and **<DOWN>** buttons to highlight the **Pan Angle** option.
5. Press **<ENTER>**. The three digits to the right will show in green.
6. Use **<UP>** or **<DOWN>** to select **180**, **360**, or **540**.
7. Press **<ENTER>** to select the setting.

### Tilt Range

Setting the tilt angle range is useful when there is an area of the room that the Intimidator™ Wash Zoom 250 IRC should not illuminate.

To set the range of the tilt movement, do the following:

1. Press **<MENU>** repeatedly until 4 icons show on the display.
2. Use **<UP>** and **<DOWN>** to highlight the **Setup** icon.
3. Press **<ENTER>**. The **Setup** options will show on the display.
4. Use **<UP>** and **<DOWN>** to highlight the **Tilt Angle** option.
5. Press **<ENTER>**. The three digits to the right will show in green.
6. Use **<UP>** or **<DOWN>** to select **90**, **180**, or **270**.
7. Press **<ENTER>** to select the setting.

---

## Movement Speed

The movement, or pan and tilt speed, can be adjusted and will affect the speed of the Auto and Sound modes.

To set the pan and tilt speed, do the following:

1. Press **<MENU>** repeatedly until 4 icons show on the display.
2. Use **<UP>** and **<DOWN>** to highlight the **Setup** icon.
3. Press **<ENTER>**. The **Setup** options will show on the display.
4. Use **<UP>** and **<DOWN>** to highlight the **P/T Speed** option.
5. Press **<ENTER>** and **Normal**, **Fast**, or **Slow** will show in green.
6. Use **<UP>** or **<DOWN>** to select the desired speed.
7. Press **<ENTER>** to select the setting.

## Fan Operation

The fans in the unit can be set to **Full** to remain on or set to **Auto** to run only when the product is hot enough to need a fan.

To set the fans to **Full** or **Auto**, do the following:

1. Press **<MENU>** repeatedly until 4 icons show on the display.
2. Use **<UP>** and **<DOWN>** to highlight the **Setup** icon.
3. Press **<ENTER>**. The **Setup** options will show on the display.
4. Use **<UP>** and **<DOWN>** to highlight the **Fans** option.
5. Press **<ENTER>**. The words **Full** or **Auto** will show in green.
6. Use **<UP>** or **<DOWN>** to switch between **Full** and **Auto**.
7. Press **<ENTER>** to select the setting.

## Display ON/OFF

The display can be set to stay on permanently (**ON**), or to go off (**OFF**) when the menu is not being used.

If the display is set to **ON**, it will remain in any given menu for 30 seconds of inactivity, and then it will return to a home screen that shows the product's current mode and DMX address.

If the display is set to **OFF**, it will remain in any given menu for 30 seconds of inactivity, and then it will go blank and show nothing.

To set the display **ON** or **OFF**, do the following:

1. Press **<MENU>** repeatedly until 4 icons show on the display.
2. Use the **<UP>** and **<DOWN>** buttons to highlight the **Setup** icon.
3. Press **<ENTER>**. The **Setup** options will show on the display.
4. Use the **<UP>** and **<DOWN>** buttons to highlight the **Display** option.
5. Press **<ENTER>**. The words **ON** or **OFF** will show in green.
6. Use **<UP>** or **<DOWN>** to switch between **ON** and **OFF**.
7. Press **<ENTER>** to select the setting.



**If the display is set to OFF, it will come back on when the IRC-6 is used or when any menu button is pressed; however, it will not come on when it receives DMX control.**

## Display Orientation

The display can show the screen in two directions, one for when the fixture is standing and one for when it is mounted upside-down.

To set the display orientation, do the following:

1. Press **<MENU>** repeatedly until 4 icons show on the display.
2. Use **<UP>** and **<DOWN>** to highlight the **Setup** icon.
3. Press **<ENTER>**. The **Setup** options will show on the display.
4. Use **<UP>** and **<DOWN>** to highlight the **Screen Rev** option.
5. Press **<ENTER>**. The words **ON** or **OFF** will show in green.
6. Use **<UP>** or **<DOWN>** to switch between **ON** (upside-down display) and **OFF** (normal display).
7. Press **<ENTER>** to select the setting.

---

## Dimming Curve

The dimming curve can be adjusted to change how the light brightens and dims. If the factory default is not a suitable setting, and the dimming curve of this light needs to match more closely to that of another light, adjust this setting as follows.

To adjust the dimming curve, do the following:

1. Press **<MENU>** repeatedly until 4 icons show on the display.
2. Use **<UP>** and **<DOWN>** to highlight the **Setup** icon.
3. Press **<ENTER>**. The **Setup** options will show on the display.
4. Use **<UP>** and **<DOWN>** to highlight the **Dimmer Curve** option.
5. Press **<ENTER>** and **Square**, **I Squa**, **SCurve**, or **Linear** will show in green.
6. Use **<UP>** or **<DOWN>** to select the desired option.
7. Press **<ENTER>** to select the setting.

## Dimming Speed

The dimming speed can be adjusted to change how quickly the light brightens and dims. If the factory default is not a suitable setting, and the dimming speed of this light needs to match more closely to that of another light, adjust this setting as follows.

To adjust the dimming speed, do the following:

1. Press **<MENU>** repeatedly until 4 icons show on the display.
2. Use **<UP>** and **<DOWN>** to highlight the **Setup** icon.
3. Press **<ENTER>**. The **Setup** options will show on the display.
4. Use **<UP>** and **<DOWN>** to highlight the **Dimmer Speed** option.
5. Press **<ENTER>** and **Fast** or **Smooth** will show in green.
6. Use **<UP>** or **<DOWN>** to switch between **Fast** and **Smooth**.
7. Press **<ENTER>** to select the setting.

## Color Balance

The color balance setting is used to set the white color of the product. This setting affects only the color of the white light of the LED. The red, green, and blue colors will remain the same.

To adjust the color balance, do the following:

1. Press **<MENU>** repeatedly until 4 icons show on the display.
2. Use **<UP>** and **<DOWN>** to highlight the **Setup** icon.
3. Press **<ENTER>**. The **Setup** options will show on the display.
4. Use **<UP>** and **<DOWN>** to highlight the **Color Balance** option.
5. Press **<ENTER>**. The product will begin emitting light and the **Color Balance** options will show on the display.
6. Use **<UP>** and **<DOWN>** to highlight the color to be adjusted.
7. Press **<ENTER>**. The number to the right will show in green.
8. Use **<UP>** or **<DOWN>** to select a value between **100** and **255**. The higher the number, the more of the color is included in the white setting.
9. Press **<ENTER>** to select the value setting.
10. Repeat steps 6 through 9 to adjust the remaining colors until the desired white color is emitted from the product.



**Upon entering the color balance menu, the product will emit a white light. After exiting the color balancing menu, the product will return to the currently selected operations mode. If there is no activity for 30 seconds, the product will exit the color balance menu and return to the currently selected operations mode.**



---

## Sensitivity

The sensitivity setting adjusts the sensitivity of the product's microphone. If the product is not responding to the beat of the music in Sound mode, set the sensitivity to a higher number until the product responds.

To adjust the sensitivity setting, do the following:

1. Press **<MENU>** repeatedly until 4 icons show on the display.
2. Use **<UP>** and **<DOWN>** to highlight the **Setup** icon.
3. Press **<ENTER>**. The **Setup** options will show on the display.
4. Use **<UP>** and **<DOWN>** to highlight the **Sensitivity** option.
5. Press **<ENTER>**. The number to the right will show in green.
6. Use **<UP>** or **<DOWN>** to select a sensitivity level. The least sensitive is **1** and the most sensitive is **100**.
7. Press **<ENTER>** to select the setting.

## Reset

Resetting will restart the product. It does not change any settings. Resetting is a helpful troubleshooting tool, and can be used if the product has stopped responding to control, or if the control system has suffered a failure.

To reset the product, do the following:

1. Press **<MENU>** repeatedly until 4 icons show on the display.
2. Use **<UP>** and **<DOWN>** to highlight the **Setup** icon.
3. Press **<ENTER>**. The **Setup** options will show on the display.
4. Use **<UP>** and **<DOWN>** to highlight the **Reset** option.
5. Press **<ENTER>**. The product will immediately reset.

## Reset to Factory Defaults

Resetting to factory defaults will clear out all customized settings and return the settings to the factory defaults. Resetting to factory defaults can be used if the product is behaving inconsistently.

To reset the product to factory default settings, do the following:

1. Press **<MENU>** repeatedly until 4 icons show on the display.
2. Use **<UP>** and **<DOWN>** to highlight the **Setup** icon.
3. Press **<ENTER>**. The **Setup** options will show on the display.
4. Use **<UP>** and **<DOWN>** to highlight the **Factory Set** option.
5. Press **<ENTER>**. The product will immediately reset to factory default settings.

## System Information

To see the product's current software version, running mode, DMX address and temperature, do the following:

1. Press **<MENU>** repeatedly until 4 icons show on the display.
2. Use **<UP>** and **<DOWN>** to highlight the **Sys Info** icon.
3. Press **<ENTER>**. The current information about the product will show on the display.

---

## 5. TECHNICAL INFORMATION

### **Product Maintenance**

Dust build-up on the lens reduces light output. Dust build-up on the body and fans can cause overheating and mechanical wear, which can reduce the usable life of the product.

To maintain optimum performance and minimal wear in a normal environment, clean the product at least twice a month. If the environment is particularly dusty, clean the product more often.

For best results follow the suggestions listed below:

- Never clean the product when it is plugged into a power source.
- Only clean the product when it is at room temperature.
- Use a vacuum (or dry compressed air) and a soft brush to remove dust collected on the external surfaces and in the vents.
- Use a mild soap solution, ammonia-free glass cleaner, or isopropyl alcohol to clean all the external optics and glass or transparent surfaces.
- Apply the cleaning solution directly to a soft, lint-free cotton cloth or a lens cleaning tissue.
- Gently wipe dirt and grime to the outside edges of the external optics and glass or transparent surfaces.
- Gently polish the external optics and glass or transparent surfaces until they are free of haze and lint.



**Always dry the external optics and glass/transparent surfaces carefully after cleaning them.**



**Do not spin the cooling fans while blowing compressed air into them.**

## 6. TECHNICAL SPECIFICATIONS

<b>Dimensions and Weight</b>	<b>Length</b>	<b>Width</b>	<b>Height</b>	<b>Weight</b>
	7.1 in (180 mm)	9.4 in (240 mm)	13 in (330 mm)	12.2 lb (5.6 kg)
<b>Note:</b> Dimensions in inches are rounded to the nearest decimal digit.				
<b>Power</b>	<b>Power Supply Type</b>	<b>Range</b>	<b>Voltage Selection</b>	
	Switching (internal)	100 to 240 VAC, 50/60 Hz	Auto-ranging	
	<b>Parameter</b>	<b>120 V, 60 Hz</b>	<b>230 V, 50 Hz</b>	
	Consumption	193 W	173 W	
	Operating current	1.5 A	0.8 A	
	Fuse	F 5 A, 250 V	F 5 A, 250 V	
<b>Light Source</b>	<b>Power I/O</b>	<b>US/Canada</b>	<b>UK/Worldwide</b>	
	Power input connector	IEC	IEC	
	Power output connector	Edison (US)	N/A	
	Power cord plug	Edison (US)	Local plug	
	Power linking current (units)	8 A (5 units)	8 A (9 units)	
<b>Photo Optic</b>	<b>Type</b>	<b>Power</b>	<b>Lifespan</b>	
	LED	20 W	50,000 hours	
	<b>Color</b>	<b>Quantity</b>	<b>Current</b>	
	RGBW	7	3.7 A	
<b>Thermal</b>	<b>Parameter</b>			
	Illuminance @ 2 m (14°)	14,520 lux		
	Illuminance @ 2 m (58°)	2,348 lux		
	Zoom angle	14° to 58°		
	Strobe rate	0–20 Hz		
	Pan and Tilt	540° pan		270° tilt
	Pan/Tilt ranges	180°/360°/540° pan ranges	90°/180°/270° tilt ranges	
<b>DMX</b>	<b>Maximum External Temp.</b>	<b>Cooling System</b>		
	104 °F (40 °C)	Fan-cooled		
<b>Ordering</b>	<b>I/O Connectors</b>	<b>Connector Type</b>	<b>Channel Range</b>	
	3-pin XLR	Sockets	7 or 14	
<b>Ordering</b>	<b>Product Name</b>	<b>Item Code</b>	<b>Item Number</b>	
	Intimidator™ Wash Zoom 250 IRC	08010788	781462211363	

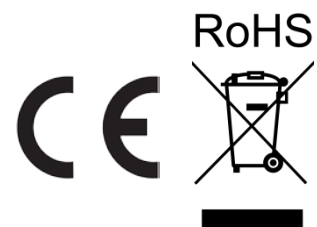

---

# RETURNS

## General Info

To return a product or request support:

- In the U.S., contact CHAUVET® World Headquarters (see below).
- In the UK or Ireland, contact CHAUVET® Europe Ltd. (see below).
- In Mexico, contact CHAUVET® Mexico (see below).
- In any other country, DO NOT contact CHAUVET®. Contact your distributor. See [www.chauvetlighting.com](http://www.chauvetlighting.com) for distributors outside the U.S., United Kingdom, Ireland, or Mexico.



## U.S., UK, Ireland, and Mexico

**If you live outside the U.S., United Kingdom, Ireland, or Mexico, contact your distributor of record and follow their instructions on how to return CHAUVET® products to them. Visit our website for contact details.**

Call the corresponding CHAUVET® Technical Support office and request a Return Merchandise Authorization (RMA) number before shipping the product. Be prepared to provide the model number, serial number, and a brief description of the reason for the return.

You must send the merchandise prepaid, in its original box, and with its original packing and accessories. CHAUVET® will not issue call tags.

Clearly label the package with the RMA number. CHAUVET® will refuse any product returned without an RMA number.



**Write the RMA number on a properly affixed label. DO NOT write the RMA number directly on the box.**

Before sending the product, clearly write the following information on a piece of paper and place it inside the box:

- Your name
- Your address
- Your phone number
- RMA number
- A brief description of the problem

Be sure to pack the product properly. Any shipping damage resulting from inadequate packaging will be your responsibility. FedEx packing or double-boxing are recommended.



**CHAUVET® reserves the right to use its own discretion to repair or replace returned product(s).**

---

## Contact Us

### WORLD HEADQUARTERS - CHAUVET®

#### General Information

Address: 5200 NW 108<sup>th</sup> Avenue  
Sunrise, FL 33351  
Voice: (954) 577-4455  
Fax: (954) 929-5560  
Toll free: (800) 762-1084

#### Technical Support

Voice: (954) 577-4455 (Press 4)  
Fax: (954) 756-8015  
Email: [tech@chauvetlighting.com](mailto:tech@chauvetlighting.com)

World Wide Web [www.chauvetlighting.com](http://www.chauvetlighting.com)

### UNITED KINGDOM AND IRELAND - CHAUVET® Europe Ltd.

#### General Information

Address: Unit 1C  
Brookhill Road Industrial Estate  
Pinxton, Nottingham, UK  
NG16 6NT  
Voice: +44 (0)1773 511115  
Fax: +44 (0)1773 511110

#### Technical Support

Email: [uktech@chauvetlighting.com](mailto:uktech@chauvetlighting.com)

World Wide Web [www.chauvetlighting.co.uk](http://www.chauvetlighting.co.uk)

### MEXICO - CHAUVET® Mexico

#### General Information

Address: Av. Santa Ana 30  
Parque Industrial Lerma  
Lerma, Mexico C.P. 52000  
Voice: +52 (728) 285-5000

#### Technical Support

Email: [servicio@chauvet.com.mx](mailto:servicio@chauvet.com.mx)

World Wide Web [www.chauvet.com.mx](http://www.chauvet.com.mx)

Outside the U.S., United Kingdom, Ireland, or Mexico, contact your dealer. Follow their instructions to request support or to return a product. Visit our website for contact details.

## Free Manuals Download Website

<http://myh66.com>

<http://usermanuals.us>

<http://www.somanuals.com>

<http://www.4manuals.cc>

<http://www.manual-lib.com>

<http://www.404manual.com>

<http://www.luxmanual.com>

<http://aubethermostatmanual.com>

Golf course search by state

<http://golfingnear.com>

Email search by domain

<http://emailbydomain.com>

Auto manuals search

<http://auto.somanuals.com>

TV manuals search

<http://tv.somanuals.com>