



TECHNICAL REFERENCE & MANUAL

# LEGEND 250RX DMX-1655R

---



CHAUVET  
3000 North 29<sup>th</sup> Ct.  
Hollywood, FL 33020  
Tel: 954-929-1115 Fax: 954-929-5560

**[www.CHAUVETlighting.com](http://www.CHAUVETlighting.com)**

# Table of Contents

<b>WARRANTY INFORMATION .....</b>	<b>3</b>
<b>INTRODUCTION .....</b>	<b>4</b>
Safety Instructions .....	4
Caution .....	4
Technical Specifications .....	5
Product Overview .....	6
What is enclosed .....	6
<b>BEFORE YOU BEGIN .....</b>	<b>7</b>
Unpacking Instructions .....	7
Mounting .....	7
Powering .....	7
<b>OPERATING INSTRUCTIONS .....</b>	<b>8</b>
Control panel overview .....	8
Display panel diagram .....	9
DMX-512 addressing .....	10
Stand alone (master/slave) operation .....	10
Slave & 2 Light Show operation .....	11
Color presets .....	11
Pan invert .....	11
Tilt invert .....	12
LCD reverse display .....	12
Focus adjustment .....	12
Self test mode .....	12
Fixture life counter .....	13
Fixture reset .....	13
Control Panel Reset .....	13
DMX Reset .....	13
CA-8 Easy Controller .....	13
DMX-512 attributes .....	14
Pre-programmed shows .....	15
Channel 14 .....	15
Channel 15 .....	15
DMX-512 connection .....	16
Inserting/Exchanging rotating gobos .....	17
Lamp replacement .....	17
<b>APPENDIX .....</b>	<b>18</b>
Maintenance .....	18
DMX Primer .....	18
Returns Procedure .....	18
Claims .....	18
Fixture Cleaning .....	18
General Troubleshooting .....	19

Issue Date:	December 2003		
Rev. No.	Version	Date	Description
0	1.11	Jan 2004	DMX-1655 Users Guide version 1.10: Revised: V.M. at CHAUVET

# Warranty Information

We take great pride in the quality, value and performance of our products and believe that it should offer you trouble free operation throughout its lifetime providing you take care to follow the simple instructions in this manual.

## LIMITED WARRANTY USA

- a) CHAUVET provides, from the date of purchase, to the original purchaser, a 24-month limited warranty on all DMX products, a 12-month limited warranty on special effect fixtures and controllers and a 3-month limited warranty on items with an "NV" prefix. This limited warranty covers manufacturing defects in material and workmanship only. At the time of service, the owner will need to be able to provide evidence of date and place of purchase and serial number.
- b) CHAUVET does not cover damage or failure caused by abuse, misuse, faulty installation, improper maintenance, or any repairs not carried out by CHAUVET.
- c) Items which are not covered by warranty are those considered as parts which are prone to failure due to general wear and tear. For example – lamps, fuses, brushes and belts. Laser diodes carry a (90day) warranty. For foggers, see user manual.
- d) There will be no obligations or liability on the part of CHAUVET for consequential damages arising from the use of the product or any indirect damages with respect to loss of property, revenue, or costs for removal, installation, or re-installation.
- e) For warranty service the product must be reported to CHAUVET to receive a unique RA# (returns authorization number) and at that time you will be advised of where to send the faulty product.
- f) All shipping charges for returns should be pre-paid. If the requested repairs or service are within the terms of this warranty then the item will be returned to you on completion without any charge. The unit must be in its original packaging with any original accessories. CHAUVET will not be responsible or accept any liabilities for any loss or damage to additional items which are sent with returned product.
- g) If this product is not covered under the terms of this warranty, CHAUVET will advise you of the costs to carry out any repairs necessary and the unit will be shipped to you on receipt of payment for the work including the return freight charges.
- h) Please allow 2 to 4 weeks for return of your product. Under normal circumstances we try to ensure we carry out warranty repairs within 5 working days. We cannot be held responsible for delays in shipping.

Title	First Name	Initials	Last Name	
Address				Apt.
City		State	Or Province	
Country	Zip Code	Or Postal Code	Date of Birth	
e-mail		Telephone # (include area code)		
Date of Purchase	Purchase Price (before tax)	Model	Serial #	
Dealer		City	Country	

To return via fax: 954-929-5560

To return via mail: CHAUVET U.S.A  
Warranty Registration  
3000 North 29<sup>th</sup> Ct.  
Hollywood, FL 33020 U.S.A

# Introduction

## Safety Instructions



**Please read these instructions carefully, which includes important information about the installation, usage and maintenance?**

- Please keep this User Guide for future consultation. If you sell the unit to another user, be sure that they also receive this instruction booklet.
- Always make sure that you are connecting to the proper voltage and that the line voltage you are connecting to is not higher than that stated on decal or rear panel of the fixture.
- This product is intended for indoor use only!
- To prevent risk of fire or shock, do not expose fixture to rain or moisture. Make sure there are no flammable materials close to the unit while operating.
- The unit must be installed in a location with adequate ventilation, at least 50cm from adjacent surfaces. Be sure that no ventilation slots are blocked.
- Always disconnect from power source before servicing or replacing lamp or fuse and be sure to replace with same lamp source.
- Secure fixture to fastening device using a safety chain. Never carry the fixture solely by its head. Use its carrying handles.
- Maximum ambient temperature is  $T_a: 40^{\circ}\text{C}$ . Do not operate fixture at temperatures higher than this.
- In the event of serious operating problem, stop using the unit immediately. Never try to repair the unit by yourself. Repairs carried out by unskilled people can lead to damage or malfunction. Please contact the nearest authorized technical assistance center. Always use the same type spare parts.
- Don't connect the device to a dimmer pack.
- Make sure power cord is never crimped or damaged.
- Never disconnect power cord by pulling or tugging on the cord.
- Avoid direct eye exposure to lamp. Gas discharge lamps generate UV radiation. Never operate the lamp without appropriate protection as it could damage skin and eyes. These lamps operate at high pressures and there is always a slight risk of tube rupture. The risk of rupture increases with age, temperature and improper handling of the lamp. These lamps also generate UV radiation. The UV radiation that is emitted extends well below 287nm, which is considered the point at which the UV radiation becomes imminently harmful. Exposure to this short wave UV should be limited. If aligning a lamp, care must be taken to reduce the exposure time to the lamp. Never look directly at any lamp while it is powered on. Read the booklet that accompanies each lamp and heed attention to the warnings concerning exposure to skin and eyes. Use appropriate eye protection to block all UV rays. Do not use ordinary sunglasses.

### Caution

- **There are no user serviceable parts inside the unit. Do not open the housing or attempt any repairs yourself. In the unlikely event your unit may require service, please contact your nearest dealer.**

## INTRODUCTION

### Technical Specifications

Power	AC 120V~60Hz or 230V/240V/250V 50/60Hz
Lamp	Discharge lamp MSD 250W GY9.5 CHAUVET Model No. US-HSD250 or CH-MSD250
Dimensions	14.2in x 15.6in x 19.8in / 360mm x 397mm x 503mm
Shipping	57.2 Lbs / 26 Kg Master Packed 1pc/57.2 Lbs
Control	DMX-512 via XLR 3-Pin Connectors, IN & OUT Operates on 16 Channels of DMX
Optical System	Standard 13° focused beam angle
Pan	540° in 2.8 seconds
Tilt	270° in 1.6 seconds
Features	<ul style="list-style-type: none"> <li>▪ 7 interchangeable rotating gobos plus open 4 metal gobos 2 glass gobos 1 effect gobo</li> <li>▪ 3 extra metal gobos 2 extra effect gobos</li> <li>▪ Gobo wheel rotates with variable speed and rainbow effect</li> <li>▪ Independent color wheel with 9 dichroic lens filters plus white</li> <li>▪ Color wheel rotates with variable speed and rainbow effect</li> <li>▪ Prism: 3-facet prism rotates in both directions at variable speeds</li> <li>▪ Blackout, Independent 0-100% smooth dimming and strobe speed variable (1~10 flashes per second)</li> </ul>

Warranty | 2 Year Limited Warranty

DMX Channels

Channel	Function	Channel	Function
1	Pan Movement	9	Gobos
2	Tilt Movement	10	Gobo Rotation
3	Pan/Tilt Speed select	11	Prism
4	Dimmer	12	Prism Rotation
5	Shutter/Shaking	13	Focus
6	Color	14	Pre-programmed Show Pattern
7	Reserved	15	Pre-programmed Beam Pattern
8	Reset	16	Reset

Projection

Beam Angle: 13 Deg.

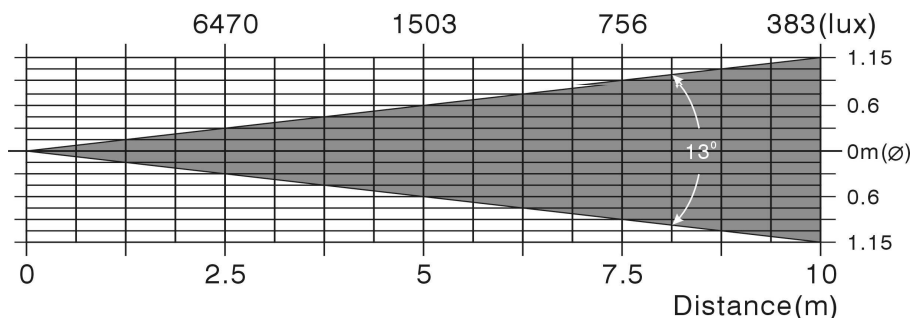

## Product Overview

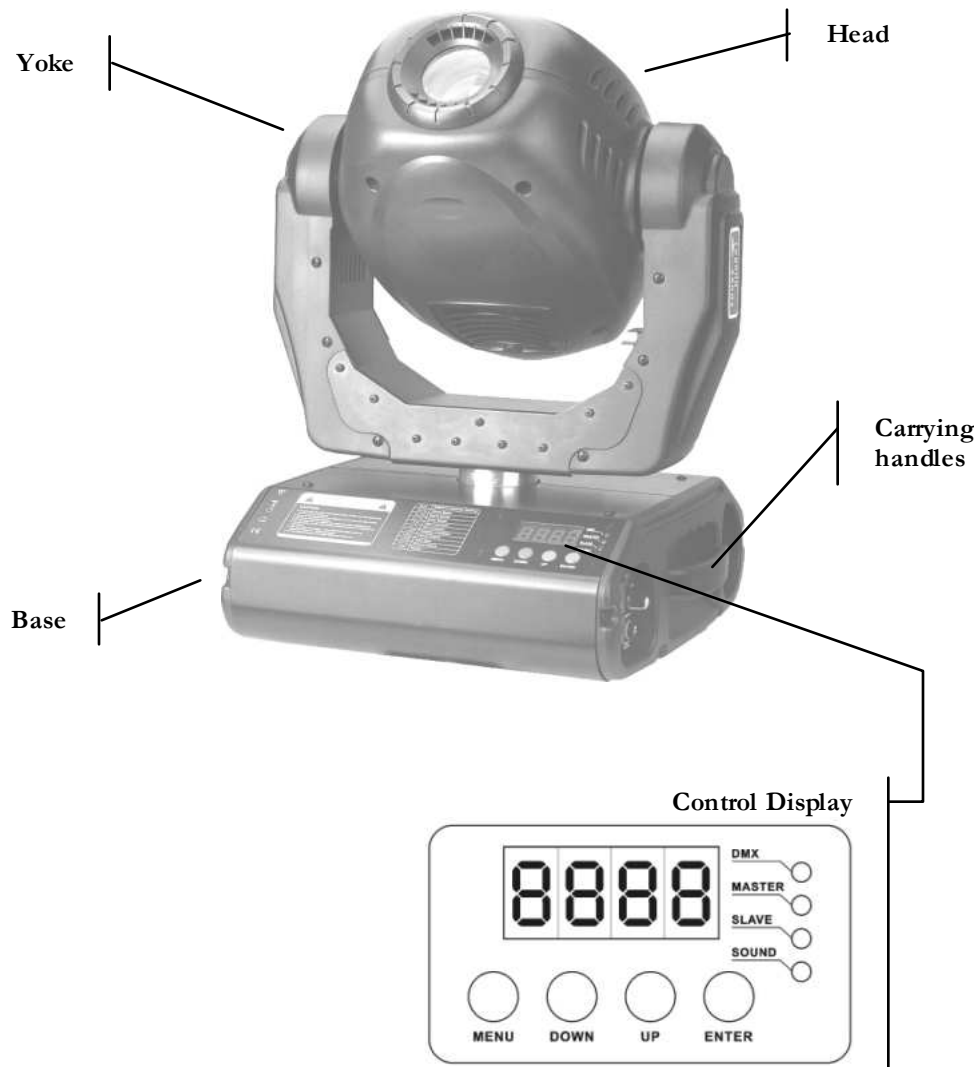

## What is enclosed

- Manual / Warranty Card
- DMX-1655 Legend 250RX
- Power cord with plug (affixed to device)
- Mounting bracket with knobs
- Lamp: MSD250 250w

# Before you Begin

## Unpacking Instructions

Immediately upon receiving a fixture, carefully unpack the carton, check the contents to ensure that all parts are present, and have been received in good condition. Notify the shipper immediately and retain packing material for inspection if any parts appear damaged from shipping or the carton itself shows signs of mishandling. Save the carton and all packing materials. In the event that a fixture must be returned to the factory, it is important that the fixture be returned in the original factory box and packing.

## Mounting

The unit should be mounted via its mounting system (as shown to the right) on the bottom of the base. Use clamps to fix the unit to truss. Always ensure that the unit is firmly fixed to avoid vibration and slipping while operating. Always ensure that the structure to which you are attaching the unit is secure and is able to support a weight of 30 kgs for each unit.

This fixture may be mounted in any position provided there is adequate room for ventilation. It is important never to obstruct the fan or vents pathway. Mount the fixture using, preferably the center mounting holes and a suitable "C" or "O" type clamp. Adjust the angle of the fixture by loosening both knobs and tilting the fixture. After finding the desired position, retighten both knobs. When selecting installation location, take into consideration lamp replacement access and routine maintenance. Safety cables should always be used. Never mount in places where the fixture will be exposed to rain, high humidity, extreme temperature changes or restricted ventilation.

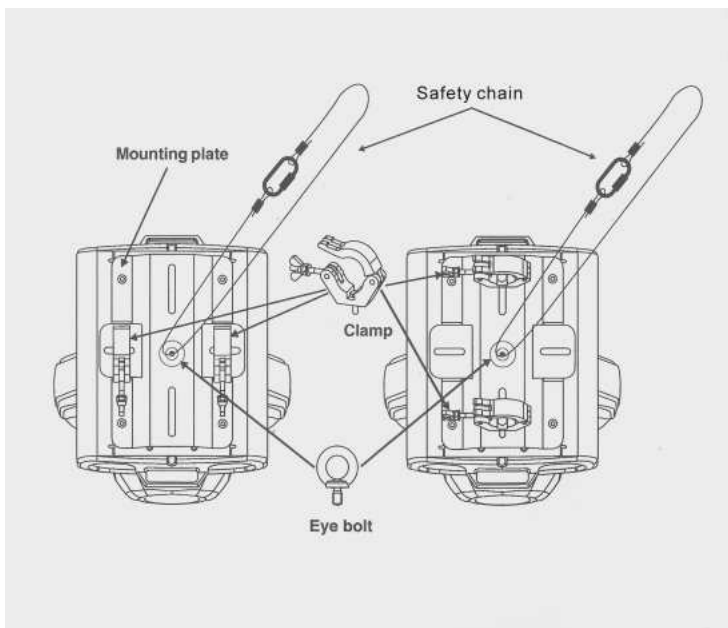

## Powering

To determine the power requirements for a particular fixture, see the label affixed to the back plate of the fixture or refer to the fixture's specifications chart. A fixture's listed current rating is its average current draw under normal conditions. All fixtures must be powered directly off a switched circuit and cannot be run off a rheostat (variable resistor) or dimmer circuit, even if the rheostat or dimmer channel is used solely for a 0% to 100% switch. Before applying power to a fixture, check that the source voltage matches the fixture's requirement. All fixtures must be connected to circuits with a suitable Earth Ground. Check the fixture or device carefully to make sure that if a voltage selection switch exists that it is set to the correct line voltage you will use.

# Operating Instructions

## Control panel overview

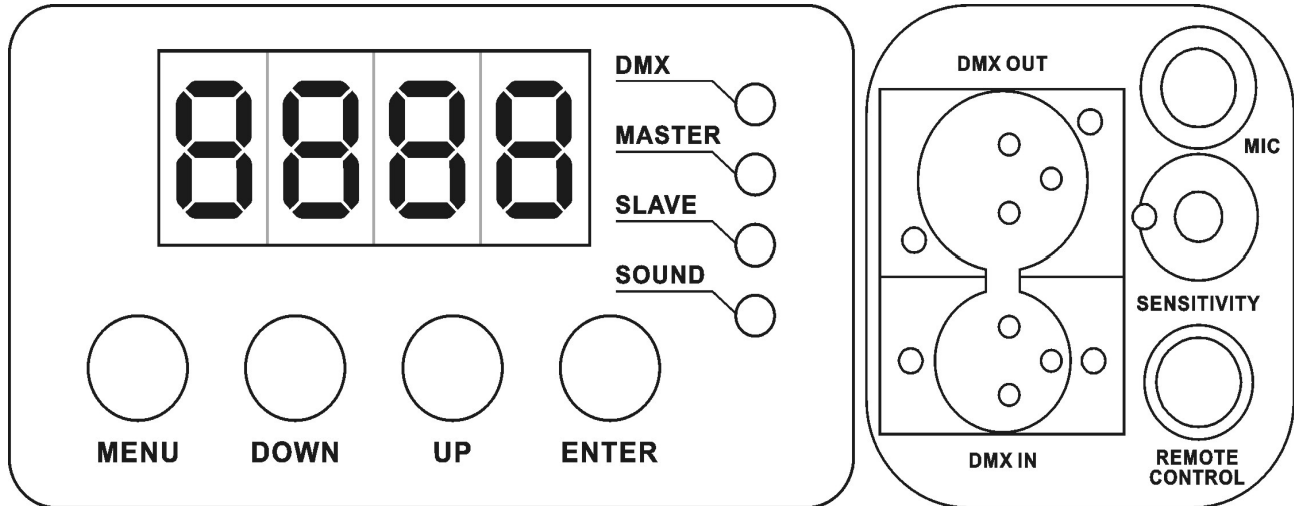

Display LED Indicators		
<b>DMX</b>	On	DMX input is present
<b>MASTER</b>	On	Master mode
<b>SLAVE</b>	On	Slave mode
<b>SOUND</b>	Flashing	Sound Activation
Control Buttons		
<b>MENU</b>	Selects programming functions	
<b>DOWN</b>	Moves backward in selected functions	
<b>UP</b>	Moves forward in selected functions	
<b>ENTER</b>	Confirms selected function	
Rear Panel		
<b>DMX OUT/IN</b>	DMX-512 connectors, Use 3-pin XLR cables	
<b>MIC</b>	Built in microphone for sound-to-light operation	
<b>SENSITIVITY</b>	Audio sensitivity adjustment	
<b>REMOTE CONTROL</b>	Accepts 1/4" connector from the "CA-8 Easy Controller" providing Stand By, Strobe/Next and Show 1 1/Slow /Show 2 functions.	



## Display panel diagram

To select any of the pre-set functions, press the **MENU** button until the desired function is shown on the display. Select the function by pressing the **ENTER** button and the display will blink. Use the **DOWN** and **UP** button to change the settings. Once the required setting has been selected, press the **ENTER** button to activate it. If you do not press the **ENTER** button, it will automatically return to the main functions without any change after idling 8 seconds. To go back to the functions without any change press the **MENU** button. The main functions are shown below:

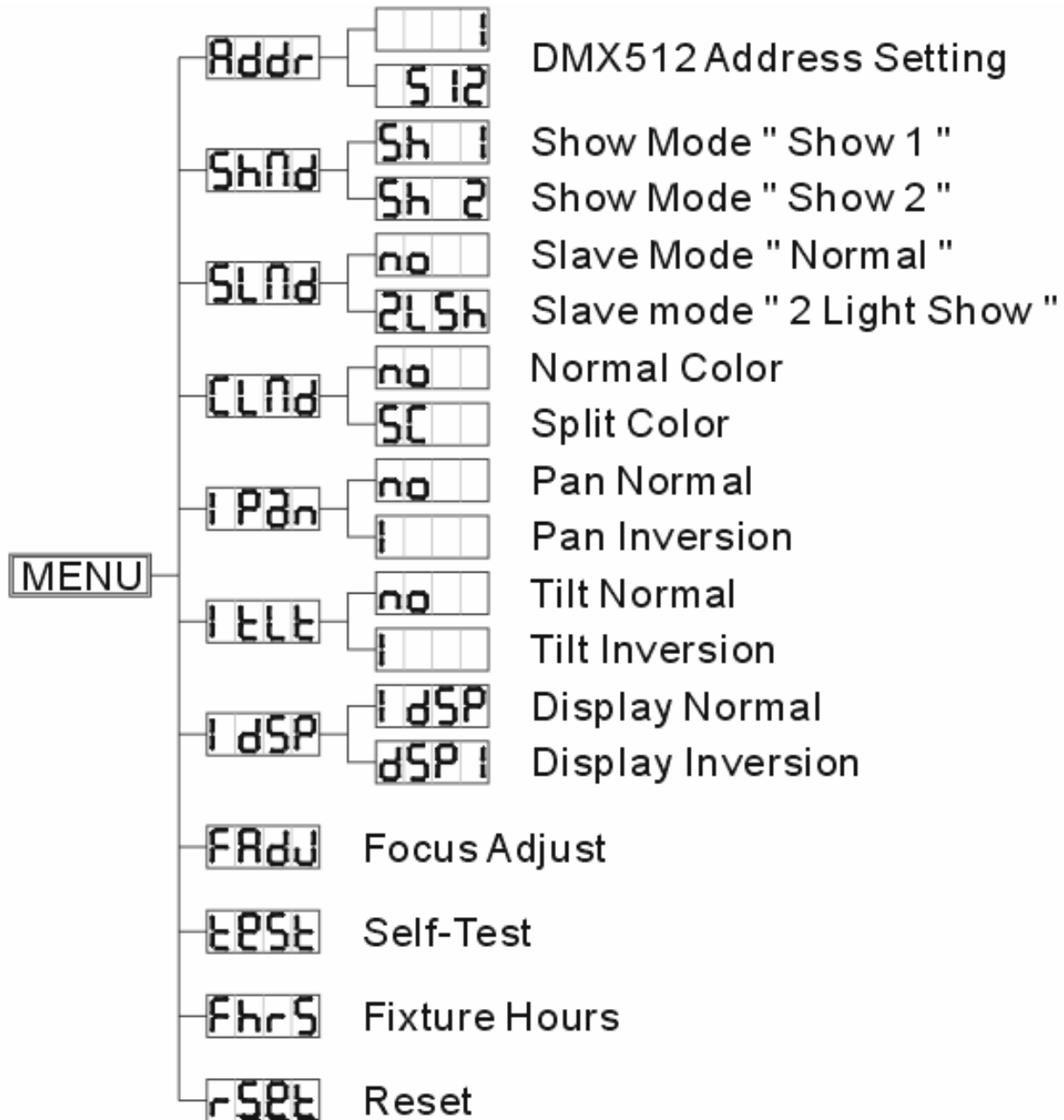

## DMX-512 addressing

This mode enables the use of a universal DMX controller device. Each fixture requires a "start address" from 1 to 511. A fixture requiring one or more channels for control begins to read the data on the channel indicated by the start address. For example, a fixture that occupies or uses 6 channels of DMX and was addressed to start on DMX channel 100, would read data from channels: 100, 101, 102, 103, 104, and 105. Choose start addresses so that the channels used do not overlap and note the start address selected for future reference. The Legend 250RX operates using 16 channels of DMX control.

If this is your first time addressing a fixture using the DMX-512 control protocol than I suggest jumping to the Appendix Section and read the heading "DMX Primer". It contains very useful information that will help you understand its use.

Upon powering up the unit, you will notice that it will display "AE16". In addition, the fixtures electronics will load up its programming and home (adjust) its motors to a starting position. The sequence of events should take no more than 20 seconds and it is necessary for the fixture to operate correctly. During this time you will hear motor and mechanical movement inside the fixture. After this initial power-up sequence, if the fixture receives no DMX signal, it will enter into a stand alone mode. Be sure to power up your DMX controller device before the lighting fixture to avoid unwanted auto mode operation.



1. Press the **MENU** button until the display reads **Addr**.
2. Press the **ENTER** button to select DMX addressing. The selection is confirmed when **Addr** begins to blink. You must make a selection within 8 seconds.
3. Press the **UP** and **DOWN** buttons to increase or decrease values until the desired value is achieved.
4. Press the **ENTER** button to activate selection.

Example Diagram: First 4 fixtures assigned.



**NOTE!** It is not necessary to turn the unit off when changing the DMX address.

## Stand alone (master/slave) operation

By linking the units under a master/slave control mode, the first unit can direct additional units to create a sound activated, synchronized light show. This is very useful for mobile DJs who want to setup and run a show quickly.

In this mode the fixture is assigned a master status and is indicated by the **MASTER LED**. If the fixture is not connected to a controller then it will automatically enter a sound activated state. You can adjust the mic sensitivity pod on the fixture for optimum sound recognition.

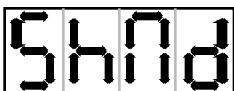

1. Press the **MENU** button until the display reads **Show**.
2. Press the **ENTER** button to select Show Mode. The selection is confirmed when **Show** begins to blink. You must make a selection within 8 seconds.
3. Press the **UP** and **DOWN** buttons to toggle between the 2 pre-programmed show modes in the fixture. Show 1 **Sh 1** and Show 2 **Sh 2**
4. Press the **ENTER** button to activate selection.



Typical use for Show 1 would be when fixture is placed on the **floor**. The tilt will move up to an angle of 210°.



Typical use for Show 2 would be when fixture is hung from the **ceiling** or flown on a truss. The tilt will move up to an angle of 90°.

**NOTE!** Chauvet's CA-8 Easy Controller offers a simple, yet effective means of selecting various other automatic program functions not directly available through the control panel. Please read the area labeled 'CA-8 Easy Controller'

### Slave & 2 Light Show operation



1. Press the **MENU** button until the display reads **SLnd**.
2. Press the **ENTER** button to select Slave Mode. The selection is confirmed when **SLnd** begins to blink. You must make a selection within 8 seconds.
3. Press the **UP** and **DOWN** buttons to toggle between the 2 slave modes.
4. Press the **ENTER** button to activate selection.



(Normal) Synchronized movement of the fixture.

(2 Light Show) Pan & tilt will be inverted on this fixture. All other programs will execute in sync.

**NOTE!** Slave mode can only be assigned when the fixture is presently connected to other fixtures.

## Color presets

The Legend 250RX provides 2 color preset modes. This affects the way you call colors on the slider on a DMX controller.



1. Press the **MENU** button until the display reads **CLnd**.
2. Press the **ENTER** button to select Color Mode. The selection is confirmed when **CLnd** begins to blink. You must make a selection within 8 seconds.
3. Press the **UP** and **DOWN** buttons to toggle between the 2 Color Modes, Normal **no** and Split Colors **SC**.
4. Press the **ENTER** button to activate selection.



Normal color mode provides indexed color presets. Only solid colors will appear as you move the channel fader on a controller.



Split color mode provides indexed solid and split color presets. Both will appear as you move the channel fader on a controller.

**NOTE!** A color scrolling preset exists in both modes. This is when the color wheel begins to rotate continuously and you can select the rate of speed, for a rainbow color like affect.

## Pan invert



1. Press the **MENU** button until the display reads **iPan**.
2. Press the **ENTER** button to select Pan Invert. The selection is confirmed when **iPan** begins to blink. You must make a selection within 8 seconds.
3. Press the **UP** and **DOWN** buttons to toggle between Normal **no** and Inverted **i**.
4. Press the **ENTER** button to activate selection.



Normal pan movement



Pan movement inverted

## Tilt invert



1. Press the **MENU** button until the display reads **TILT**.
2. Press the **ENTER** button to select Tilt Invert. The selection is confirmed when **TILT** begins to blink. You must make a selection within 8 seconds.
3. Press the **UP** and **DOWN** buttons to toggle between Normal **no** and Inverted **i**.
4. Press the **ENTER** button to activate selection.



Normal tilt movement  
Tilt movement inverted

## LCD reverse display



1. Press the **MENU** button until the display reads **LDSP**.
2. Press the **ENTER** button to reverse the display. The selection is confirmed when the display begins to blink. You must make a selection within 8 seconds.
3. Follow step # 2 again to return the display to normal.



Normal display orientation  
Orientation reversed

## Focus adjustment



Focus adjustment enables the user to set a lens focus on any of 5 specific focus points (x/y axis positioning). Manual focus adjustment is available in Stand-alone only.

1. Press the **MENU** button until the display reads **FADJ**.
2. Press the **ENTER** button and the fixture will automatically move to the first position which is straight up or Tilt/90°. The display also begins to blink. There are 5 selectable positions in total: Tilt/90°, Pan/0°, Pan/90°, Pan/180° & Pan/270°. Pressing **ENTER** button will advance the head to the next position. Leave in the desired position and follow the next step.
3. At this point you can manually adjust the focus by pressing the **UP** and **DOWN** buttons. The display will read numbers 1 through 255.
4. Press the **MENU** button to store this setting.

## Self test mode



1. Press the **MENU** button until the display reads **TEST**.
2. Press the **ENTER** button and the fixture will run through various self-test programs.
3. Press the **MENU** button to return to the main menu.

## Fixture life counter

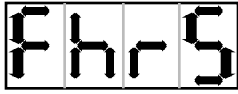

1. Press the **MENU** button until the display reads **Fhrs**.
2. Press the **ENTER** button and the display will read the number of hours the fixture has been in operation.
3. Press the **MENU** button to return to the main menu or leave for 5 seconds and fixture will return to the normal display.

## Fixture reset



### Control Panel Reset

1. Press the **MENU** button until the display reads **rSet**.
2. Press the **ENTER** button to reset the fixture. All motors and mechanical parts will return to the initial power-up positions.

### DMX Reset

Fixture Channel	Level
8	255
16	240

Figure 3.10-1

1. On your DMX controller device set the following DMX level outputs shown in “Figure 3.10-1”
2. The fixture will reset when both of the fixture channels shown in “Figure 3.10-1” receive the specified levels.

## CA-8 Easy Controller (Optional)

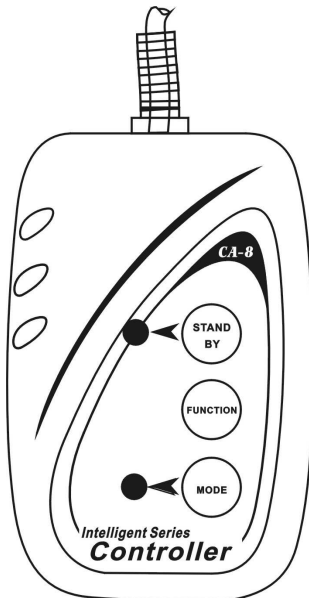

The easy remote controller is used only in master/slave mode. By connecting the 1/4” microphone jack to the first unit, you will find that the remote control on the first unit will control all the other units for Stand by, Strobe/Next/Strobe and Show 1/Slow /Show 2 functions.

### Buttons

STAND BY

### Function

Will blackout all units connected

FUNCTION or STROBE/NEXT

In Show 1	<b>Tap:</b> Steps through color and gobo presets <b>Hold:</b> Will strobe in white
In Slow	<b>Tap:</b> Every 10 taps steps through each color and the 11 <sup>th</sup> tap changes the gobo. Repeat as necessary to achieve desired result.
In Show 2	<b>Tap:</b> Steps through color and gobo presets <b>Hold:</b> Will strobe in white

FAST/SLOW

LED Status	Mode
Off	Show 1 (210° Tilt)
On	Slow Show 1 (Slow motion)
Blinking	Show 2 (90° Tilt)

**NOTE!** All movement and changes are sound activated except when in SLOW Show 1 mode. In SLOW mode, color and gobo change is user selectable using the “CA-8 Easy Controller”.

# DMX-512 attributes

DMX-512 Configuration(1)				
Channel 1	Channel 2	Channel 3	Channel 4	Channel 5
Pan	Tilt	Pan/Tilt speed select	Dimmer	Shutter Shaking
<p>540°</p> <p>270°</p> <p>0°</p>	<p>270°</p> <p>135°</p> <p>0°</p>	<p>255 Slow</p> <p>0 Fast</p>	<p>255 100%</p> <p>0 0%</p>	<p>255 Fast</p> <p>Gobo Shaking</p> <p>136 Slow</p> <p>16 Stop</p> <p>0</p>
Channel 6	Channel 7	Channel 8	Channel 9	Channel 10
Color	Reserved for future use	Reset	Gobo	Gobo Rotation
<p>255 Fast</p> <p>Loop</p> <p>128 Slow</p> <p>116 Light green</p> <p>103 Amber</p> <p>90 Magenta</p> <p>77 Pink</p> <p>64 Orange</p> <p>52 UV Purple</p> <p>39 Green</p> <p>26 Yellow</p> <p>13 Blue</p> <p>0 White</p>	<p>255</p> <p>128</p> <p>0</p>	<p>255 Reset</p> <p>0 Normal</p>	<p>255 Fast</p> <p>Loop</p> <p>128 Slow</p> <p>112 Gobo 7</p> <p>96 Gobo 6</p> <p>80 Gobo 5</p> <p>64 Gobo 4</p> <p>48 Gobo 3</p> <p>32 Gobo 2</p> <p>16 Gobo 1</p> <p>0 Open</p>	<p>255 Stop Fast</p> <p>246</p> <p>Gobo Rotation</p> <p>135 Slow</p> <p>121 Stop</p> <p>10 Fast Stop</p> <p>0</p>

## DMX-512 Configuration(2)

Channel 11	Channel 12	Channel 13	Channel 14	Channel 15	Channel 16
Prism	Prism Rotation	Focus	Pre-programmed Show Pattern	Pre-programmed Beam Pattern	Reset



*The Legend 250RX includes the following extra gobos shown here on the right!*

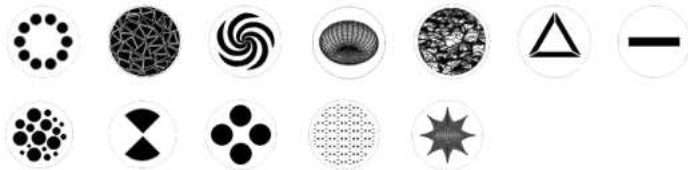

### Pre-programmed shows

**Channel 14** - As illustrated above, beginning on values 32 the stand alone shows are userselectable while in DMX control mode. All other control except pre-programs on channel15 becomes inactive.

**Channel 15** - As illustrated above and in tandem with the selection of a pre-programmed show on channel 14 various beam pattern programs can also be selected.

## DMX-512 connection

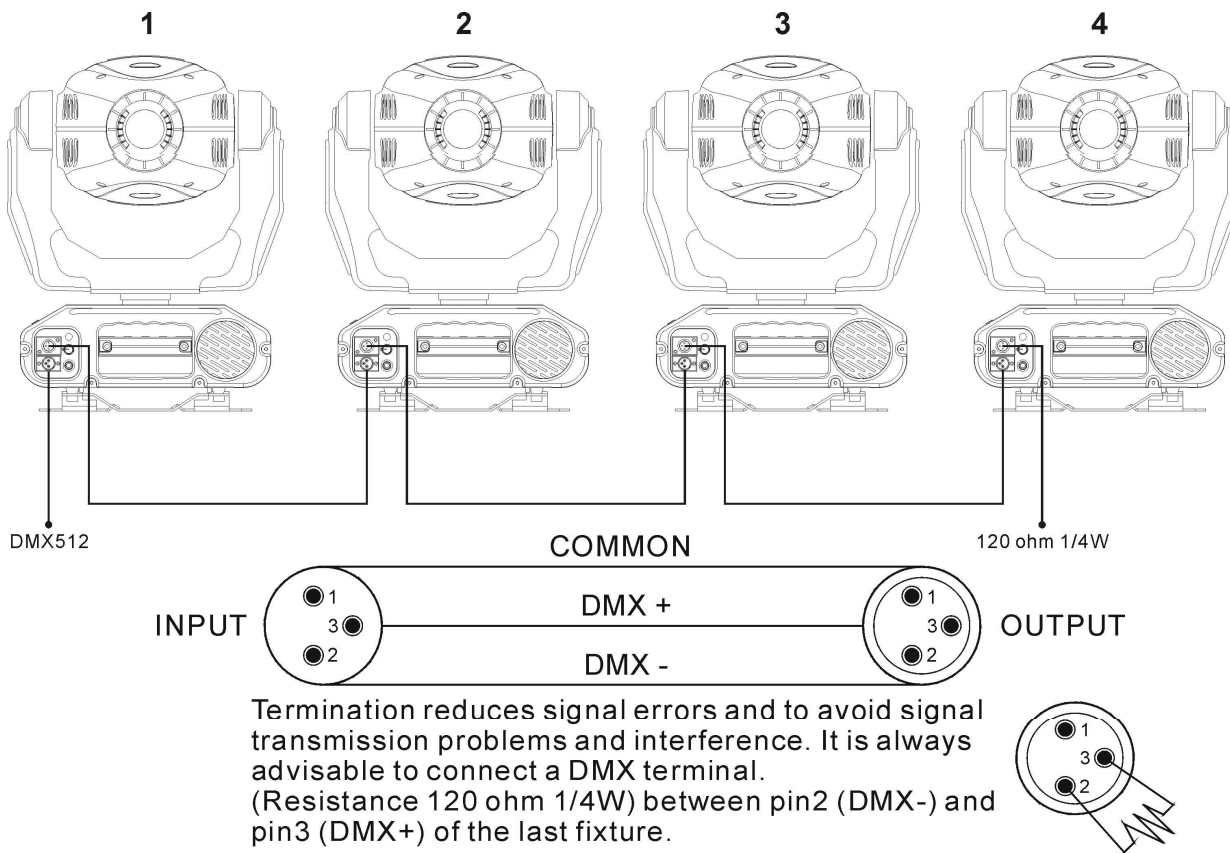

If you use a controller with a 5 pin DMX output connector, you will need to use a 5 to 3 pin adapter. Chauvet Model No: DMX5M

The last unit on the DMX chain should be terminated with a terminator. Solder a 120-ohm 1/4W resistor between pin 2(DMX-) and pin 3(DMX+) into a 3-pin XLR-plug and plug it in the DMX-output of the last unit.

Connect the units together in a “daisy chain” fashion by connecting an XLR plug from the output of the unit to the input of the next unit. The cable cannot be branched or split to a “Y” cable. DMX512 contains a high-speed signal. Inadequate or damaged cables, soldered joints or corroded connectors can easily distort the signal and shut down the system.

Each lighting unit needs to have an address set to receive the data sent by the controller. Fixtures are addressable between 1 and 512. Refer to Section 3.3 DMX addressing for further instructions.

### XLR Configuration:

3 pin XLR: Pin 1: GND, Pin 2: Negative signal (-), Pin 3: Positive signal (+)

5 pin XLR: Pin 1: GND, Pin 2: Negative signal (-), Pin 3: Positive signal (+)



## Inserting/Exchanging rotating gobos

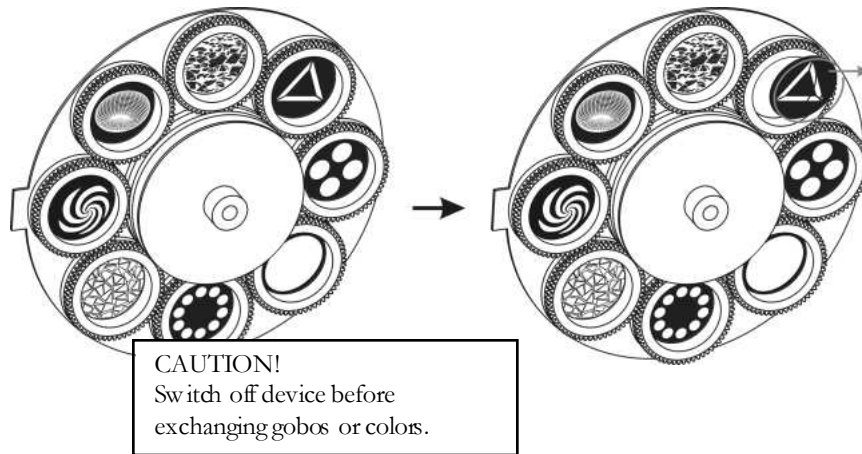

Open the cover by loosening the fastening screw at the sides of the cover. Remove the "O" ring with tweezers if available, insert the new gobo and replace the "O" ring.

**CAUTION!**

Never unscrew the screws of the rotating gobo as the ball bearing will otherwise be opened!

## Lamp replacement



**When replacing lamp, please wait 15 minutes after powering down to allow the unit cool down!**

Because of its high internal pressure, there might be a risk that the Discharge lamp could explode during operation. The lamp emits intense UV radiation which is harmful to the eyes and skin. The high luminance of the arc can cause severe damage to the retina if you look directly into the lamp source.

Always switch off the main supply and never handle the lamp or luminaries when it is hot.

Do not touch the bulb with bare hands. If this happens, clean the lamp with alcohol and wipe it with a lint free cloth before installation.

The lamp generates UV radiation. Never operate the lamp without appropriate shielding.

When burning, the lamp operates at high pressure and there is a slight risk of arc tube rupture. The risk increases with age, temperature and improper handling of the lamp. Do not use the lamp any longer than its specified life.

Make sure the lamp is located in the center of the reflector for the best spot. Adjust lamp position by screws A, B and C.

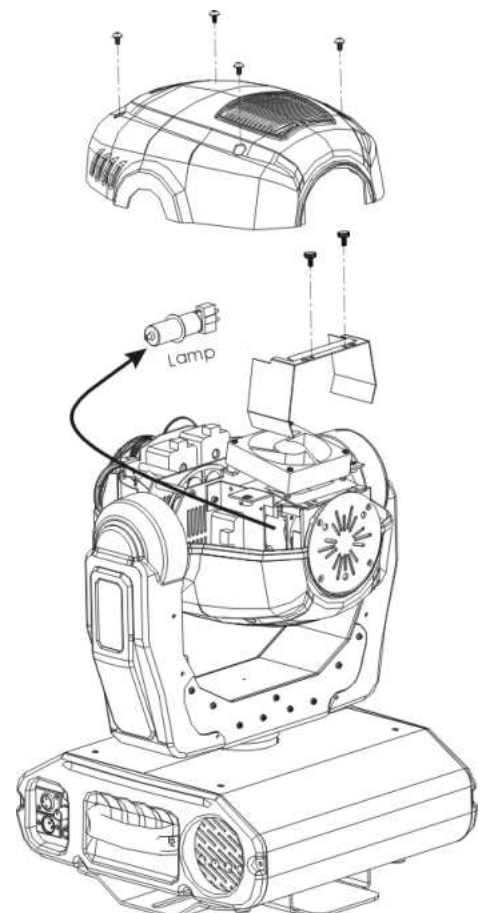
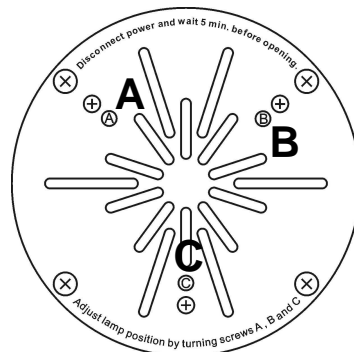

# Appendix

## Maintenance

To maintain optimum performance and minimize wear fixtures should be cleaned frequently. Usage and environment are contributing factors in determining frequency. As a general rule, fixtures should be cleaned at least twice a month. Dust build up reduces light output performance and can cause overheating. This can lead to reduced lamp life and increased mechanical wear. Be sure to power off fixture before conducting maintenance.

Unplug fixture from power. Use a vacuum or air compressor and a soft brush to remove dust collected on external vents and internal components. Clean all glass when the fixture is cold with a mild solution of glass cleaner or Isopropyl Alcohol and a soft lint free cotton cloth or lens tissue. Apply solution to the cloth or tissue and drag dirt and grime to the outside of the lens. Gently polish optical surfaces until they are free of haze and lint. Do not touch the lamp glass when cleaning fixture. Oil and dirt can cause damage and premature aging of the lamp. In the event that the lamp is touched or becomes dirty, clean the lamps with an alcohol wipe.

## DMX Primer

There are 512 channels in a DMX-512 connection. Channels may be assigned in any manner. A fixture capable of receiving DMX 512 will require one or a number of sequential channels. The user must assign a starting address on the fixture that indicates the first channel reserved in the controller. There are many different types of DMX controllable fixtures and they all may vary in the total number of channels required. Choosing a start address should be planned in advance. Channels should never overlap. If they do, this will result in erratic operation of the fixtures whose starting address is set incorrectly. You can however, control multiple fixtures of the same type using the same starting address as long as the intended result is that of unison movement or operation. In other words, the fixtures will be slaved together and all respond exactly the same.

DMX fixtures are designed to receive data through a serial Daisy Chain. A Daisy Chain connection is where the DATA OUT of one fixture connects to the DATA IN of the next fixture. The order in which the fixtures are connected is not important and has no effect on how a controller communicates to each fixture. Use an order that provides for the easiest and most direct cabling. Connect fixtures using shielded two conductor twisted pair cable with three pin XLR male to female connectors. The shield connection is pin 1, while pin 2 is Data Negative (S-) and pin 3 is Data positive (S+). CHAUVET carries 3-pin XLR DMX compliant cables, DMX-10 (33'), DMX-4.5 (15') and DMX-1.5 (5')

## Returns Procedure

Returned merchandise must be sent prepaid and in the original packing, call tags will not be issued. Package must be clearly labeled with a Return Merchandise Authorization Number (RA #). Products returned without an RA # will be refused. Call CHAUVET and request RA # prior to shipping the fixture. Be prepared to provide the model number, serial number and a brief description of the cause for the return. Be sure to properly pack fixture, any shipping damage resulting from inadequate packaging is the customer's responsibility. CHAUVET reserves the right to use its own discretion to repair or replace product(s). As a suggestion, proper UPS packing or double-boxing is always a safe method to use.

## Claims

Damage incurred in shipping is the responsibility of the shipper; therefore the damage must be reported to the carrier upon receipt of merchandise. It is the customer's responsibility to notify and submit claims with the shipper in the event that a fixture is damaged due to shipping. Any other claim for items such as missing component/part, damage not related to shipping, and concealed damage, must be made within seven (7) days of receiving merchandise.

## Fixture Cleaning

The cleaning of internal and external optical lenses and/or mirrors must be carried out periodically to optimize light output. Cleaning frequency depends on the environment in which the fixture operates: damp, smoky or particularly dirty surrounding can cause greater accumulation of dirt on the unit's optics.

- Clean with soft cloth using normal glass cleaning fluid. - Always dry the parts carefully. - Clean the external optics at least every 20 days. Clean the internal optics at least every 30/60 days.

## General Troubleshooting

Symptom	Solution(s)
Fixture has no power	Check for power on Mains. Check fixture's fuse.
Lamps cuts off sporadically	Possible bad lamp or fixture is overheating. Check the fan. Lamp may be at end of its life.
Motor movements are jerky or jumpy	Possible bad motor driver or sensors.
Beam is very dim	Clean optical system or replace lamp.
Fixture is on but there is no movement to the audio	Adjust the audio sensitivity pod.
Fixture does not respond to DMX	<ol style="list-style-type: none"> <li>DMX LED should be on. If it is not, check the DMX connector and cables for proper contact.</li> <li>If the DMX LED is on and does not respond to the channel, check the address settings and DMX polarity.</li> <li>If you have intermittent DMX signal problems, check the pins on connectors or on PCB of the unit or the previous one.</li> <li>Use another DMX controller to rule out controller issues.</li> <li>Check if the DMX cables run near or run alongside high voltage cables that may cause damage or interference to DMX interface circuit.</li> <li>Wrong DMX address in the unit. Set the proper address.</li> </ol>
Some units do not respond to the Easy Controller	<ol style="list-style-type: none"> <li>You may have a break in the DMX cabling. Check the LED for the response of the master/ slave mode signal.</li> </ol>
Does not respond to sound	<ol style="list-style-type: none"> <li>Check the unit that is not receiving DMX signal.</li> <li>Check microphone to see if it is good by tapping the microphone</li> </ol>
A channel is not working well	<ol style="list-style-type: none"> <li>The stepper motor might be damaged or the cable connected to the PCB is broken.</li> <li>The motor's drive IC on the PCB might be out of condition.</li> </ol>

### If pan belt is broken

- Turn off the main power.
- Unscrew all the screws (A) and open the base-housing cover (B).
- Unplug all the connect wires (C) from the arm to PC board and igniter.
- Unscrew (D) screws to release bridge (E).
- Unscrew the (F) screws that connect the axis gear (G).
- Change a new belt (H) by going through all connecting wires from the base, and through the bridge to the correct position.
- Set the gear axis back to the bridge and screw it. Note: do not press the belt.
- Put the belt around the axis gear and motor gear.
- Plug all the connect wires (C) that form the arm to PC board and igniter.
- Adjust the pan home position.
- Screw the base-housing cover (B).

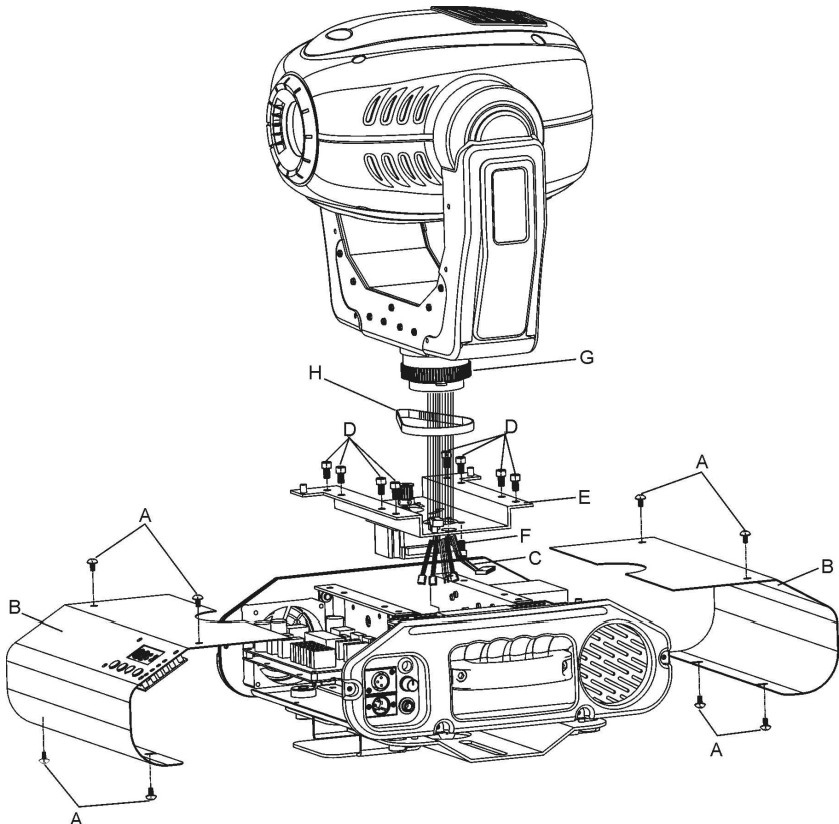

## Free Manuals Download Website

<http://myh66.com>

<http://usermanuals.us>

<http://www.somanuals.com>

<http://www.4manuals.cc>

<http://www.manual-lib.com>

<http://www.404manual.com>

<http://www.luxmanual.com>

<http://aubethermostatmanual.com>

Golf course search by state

<http://golfingnear.com>

Email search by domain

<http://emailbydomain.com>

Auto manuals search

<http://auto.somanuals.com>

TV manuals search

<http://tv.somanuals.com>