

CHICAGO

Electric

UTILITY WINCH - 2000 LBS.

Model 90282

ASSEMBLY AND OPERATING INSTRUCTIONS



3491 Mission Oaks Blvd., Camarillo, CA 93011
Visit our Web site at <http://www.harborfreight.com>

Copyright © 2003 by Harbor Freight Tools®. All rights reserved. No portion of this manual or any artwork contained herein may be reproduced in any shape or form without the express written consent of Harbor Freight Tools.

For technical questions and replacement parts, please call 1-800-444-3353

Specifications

ITEM	DESCRIPTION
Capacity	2,000 lbs.
Cable	49 feet (L) x 5/32 inches (dia.) - #12 AWG
Drum Size	1-1/4 (dia.) x 2-7/8 (L) inches
Hook	4 (L) x 5/8 inch opening; spring loaded latch
Base Plate Size	5-1/4 (L) x 4 (W) x 4-1/4 (H) inches; 2 mounting holes: 5/16 (dia.) inch
Motor Power	12 VDC, Amperage at Maximum Load = 100
Gear Reduction Ratio	153:1
Cable Speed	10.5 feet per minute (500 lb. load); 10 amp 7.5 feet per minute (1000 lb. load); 40 amps 5.9 feet per minute (1500 lb. load); 60 amps 4.2 feet per minute (2000 lb. load); 90 amps
Control Cable	8-1/2 feet, handheld pistol grip with pushbutton switches marked IN and OUT
Clutch	Free-spooling pull-out clutch release
Overall Dimensions	11-3/8 (L) x 4-1/2 (D) x 4-1/4 (H) inches
Power Cables	Switch-to-motor: 51" (L) with lugs Switch-to-battery: 68" (L) with lugs
Weight	13.9 lbs.

Save This Manual

You will need the manual for the safety warnings and precautions, assembly instructions, operating and maintenance procedures, parts list and diagram. Keep your invoice with this manual. Write the invoice number on the inside of the front cover. Keep the manual and invoice in a safe and dry place for future reference.

Safety Warnings and Precautions

WARNING: When using tool, basic safety precautions should always be followed to reduce the risk of personal injury and damage to equipment.

Read all instructions before using this tool!

1. **Keep work area clean.** Cluttered areas invite injuries.
2. **Observe work area conditions.** Do not use machines or power tools in damp or wet locations. Don't expose to rain. Keep work area well lighted. Do not use electrically powered tools in the presence of flammable gases or liquids.

3. **Keep children away.** Children must never be allowed in the work area. Do not let them handle machines, tools, or extension cords.
4. **Store idle equipment.** When not in use, tools must be stored in a dry location to inhibit rust. Always lock up tools and keep out of reach of children.
5. **Use the right tool for the job.** Do not attempt to force a small tool or attachment to do the work of a larger industrial tool. There are certain applications for which this tool was designed. It will do the job better and more safely at the rate for which it was intended. Do not modify this tool and do not use this tool for a purpose for which it was not intended.
6. **Dress properly.** Do not wear loose clothing or jewelry as they can be caught in moving parts. Protective, electrically non-conductive clothes and non-skid footwear are recommended when working. Wear restrictive hair covering to contain long hair.
7. **Do not overreach.** Keep proper footing and balance at all times. Do not reach over or across running machines.
8. **Maintain tools with care.** Keep tools sharp and clean for better and safer performance. Follow instructions for lubricating and changing accessories. Inspect tool cords periodically and, if damaged, have them repaired by an authorized technician.
9. **Disconnect power.** Unplug tool when not in use.
10. **Remove adjusting keys and wrenches.** Check that keys and adjusting wrenches are removed from the tool or machine work surface before turning on.
11. **Avoid unintentional starting.** Be sure the switch is in the Off position when not in use and before connecting power.
12. **Stay alert.** Watch what you are doing, use common sense. Do not operate any tool when you are tired.
13. **Check for damaged parts.** Before using any tool, any part that appears damaged should be carefully checked to determine that it will operate properly and perform its intended function. Check for alignment and binding of moving parts; any broken parts or mounting fixtures; and any other condition that may affect proper operation. Any part that is damaged should be properly repaired or replaced by a qualified technician. Do not use the tool if any switch does not turn On and Off properly.
14. **Replacement parts and accessories.** When servicing, use only identical replacement parts. Use of any other parts will void the warranty. Only use accessories intended for use with this tool. Approved accessories are available from Harbor Freight Tools.
15. **Do not operate tool if under the influence of alcohol or drugs.** Read warning labels if taking prescription medicine to determine if your judgment or reflexes are impaired while taking drugs. If there is any doubt, do not operate the tool.
16. **Maintenance.** For your safety, service and maintenance should be performed regularly by a qualified technician.

17. **Pacemaker safety warning.** People with pacemakers should consult with their physician(s) before using this product; operation of equipment in close proximity to a heart pacemaker could cause interference or failure of the pacemaker.

Note: Performance of this tool may vary depending on variations in local line voltage or tool battery power. Extension cord usage may also affect tool performance.

Winch Warnings and Precautions

1. Keeps hands and body away from Fairlead (cable intake slot) when operating.
2. Secure vehicle in position with the emergency brake and wheel blocks before using winch. Never keep the vehicle in Park or in gear while using the Electric Winch.
3. Do not exceed winch load weight capacity (see Specifications on page 2).
4. Be certain winch is properly bolted to a structure (or vehicle) that can hold the winch load.
5. Always use proper couplings when connecting winch cable hook to load.
6. Do not lift items vertically. The winch was designed for horizontal pulling use only.
7. Do not overload the winch (see Specifications on page 2). It will do the job better and safer at its rated capacity.
8. Do not use inappropriate attachments to extend the length of the winch cable.
9. Never pull people or pull loads over people.
10. Never come in between the winch and the load when operating.
11. Do not apply winch to load when cable is fully extended. Keep at least 4 full turns of cable on the reel.
12. After moving an item with the winch, secure the item. Do not rely on the winch to hold it for an extended period.
13. Examine winch before using. Components may be affected by exposure to chemicals, salts, and rust.
14. Never fully extend cable while under load. Keep 4 complete turns of cable around the winch drum.
15. When loading a boat into a trailer without keel or side hull rollers, make sure the trailer is submerged in the water (but not the Winch) when the boat is loaded by the winch. Attempting to drag the boat on to the trailer while on land can cause winch failure and possible injury.
16. Never operate winch if cable shows any signs of weakening, is knotted or kinked.
17. Winch does not have a locking mechanism. Secure load after moving.
18. Do not cross over or under cable under load.
19. Do not move vehicle with cable extended and attached to load to pull it. The cable could snap.
20. Use leather gloves while handling cable.

21. Apply blocks to vehicle when parked on an incline.
22. Re-spool cable properly in a smooth pattern as shown in the photo below.
23. Not to be used for aircraft purposes.

Warning: The warnings, cautions, and instructions discussed in this instruction manual cannot cover all possible conditions and situations that may occur. It must be understood by the operator that common sense and caution are factors which cannot be built into this product, but must be supplied by the operator.

Unpacking

When unpacking, check to make sure that the following parts are included.



If any parts are missing or broken, please call Harbor Freight Tools at the number on the cover of this manual as soon as possible.

Installation

Warning: Injury or death could occur if this Electric Winch comes apart from its mounting location when it is under load. For that reason, it should only be installed by a qualified technician.

1. Align the Winch on the vehicle mounting frame (not supplied). Make drill marks through the mounting holes.

It should be aligned and secured to a solid, flat part of the vehicle (capable of supporting the Winch and load capacity) where the full rated load will be evenly distributed. Also remember that the Winch is designed for horizontal pull, not vertical.

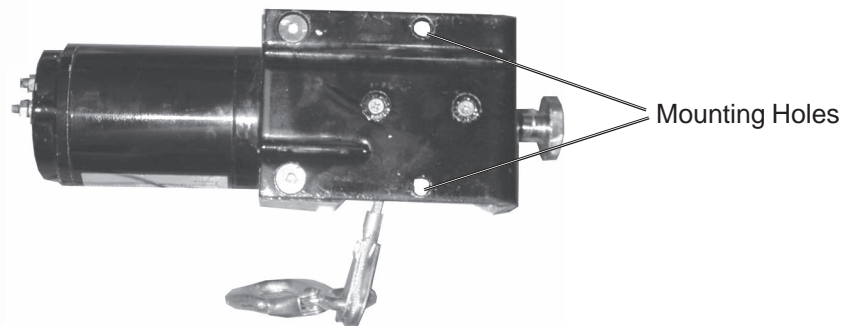

2. Remove the Winch and drill two 5/16 inch holes through the vehicle mounting frame.
3. Secure the Winch to the vehicle mounting frame using Mounting Nuts, Bolts, and Lock Washers (not supplied). Securely tighten.

6. Remove the outer connection nuts from the winch motor and connect the red cable labeled (+) positive to the red terminal. Securely tighten.
7. Connect the black cable labeled (-) negative to the black terminal. Securely tighten.

Switch to Winch Connections

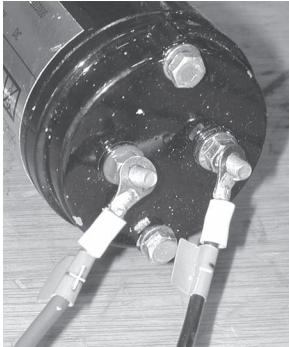

Switch to Battery Fuse Connections

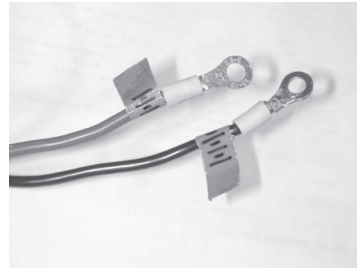

8. Route the red and black Remote Control-to-Battery cables from the Switch on the cable of the remote control, to the battery fuse box terminal strip in the vehicle. **The circuit fuse must be 70 amps.**

Caution: Remote control battery cables should not be drawn taut. Leave slack for some cable movement. Do not route cables near moving engine parts, or heated areas that could melt the cable insulation.

9. Disconnect the positive (red) cable to the vehicle battery.

You will now be making an electrical connection from the Remote Control-to-Battery cables to the vehicle electrical system (the vehicle's fuse box terminal strip).

Caution: Although the 12VDC battery cannot shock you, it can spark and heat up cables to the melting point, and can cause serious burns if not installed and fused correctly. That is why the battery is disconnected at this time.

10. Locate an appropriate positive (+ red), fused, terminal point in the vehicle fuse box able to supply 70 amps of current and connect the red Remote Control-to-Battery cable directly to the fuse terminal (without splicing wires).
11. Connect the black negative (—) cable to the vehicle metal frame, or a ground lug on or near the battery.
12. Reconnect the red positive (+) battery cable lug to the battery.
13. Disengage the clutch by pulling out, then turning the Clutch Knob (17) to lock in the OUT position.
14. Pull the cable out about five feet for testing.
15. Test Electric Winch for proper operation. Refer to the Operation section on the next page.

Operation

Note: The vehicle battery must be fully charged and the engine running before using the Electric Winch.

1. Disengage the clutch by pulling out, then turning the Clutch Knob (17) to lock in the OUT position.
2. Grab the Hook (27) with the Manual Handle (25) and pull the cable to the desired length, then attach the Hook to item being pulled. Make sure the Hook spring-loaded latch is set.

Caution: Always leave at least four turns of cable on the drum. Review Winch Safety Warnings and Precautions on page 3 before continuing.

3. Re-engage the clutch by turning the Clutch Knob until it locks in the IN position.

Caution: Avoid damaging the vehicle transmission. Do not have the transmission in Park or in any gear. Set the Emergency Brake and place wheel chocks, then put in neutral.

4. While standing aside of the tow path, press (and hold) the IN pushbutton on the Remote Control to pull the load. If the load will not move, release pull switch and check for obstacles blocking the load, or check to see if load is too heavy for Winch capacity.

Press (and hold) the OUT pushbutton to release the load. Wait until the motor stops before reversing directions.

5. When the pulling is complete, secure the load so it cannot move in either direction.

Caution: The Utility Winch is designed for intermittent use only, and should not be used in a constant duty application. The duration of the pulling job should be kept as short as possible. If the Winch motor becomes very hot to the touch, stop the Winch and let it cool down for several minutes. Never pull for more than one minute at or near the rated load. Do not maintain power to the Winch if the motor stalls as it can damage the motor or gears.

Maintenance

Lubrication

1. All moving parts within the Winch have been lubricated using high temperature lithium grease at the factory. No internal lubrication is required.
2. Lubricate cable periodically using a light penetrating oil.

Cable Assembly Replacement (to be performed only by a qualified service tech.)

1. Move Clutch Handle to the OUT position.
2. Extend Wire Rope (27) cable to its full length. Note how the existing cable is connected to the inside of the drum.
3. Remove old Cable Assembly and attach new one.

Caution: Do not replace with inferior cable. Always use the approved replacement part

from Harbor Freight Tools.

4. Retract Cable onto cable drum being careful not to allow kinking.

General

1. Keep vehicle battery in good condition.
2. Be sure that the Winch battery cables are not drawn tight against any surfaces which could possibly damage them.
3. Periodically remove and clean cable connections to the battery fuse box and chassis ground. Corrosion will reduce performance or may cause a short.
4. Cover the cables and Winch when not in use.

Parts List

Item #	Description
1	Motor
2	Motor End Support
3	Planetary Gear Assy.
4	Inner Gear
5	Left End Support
6	Bolt M4-12
7	Axle Sleeve
8	Shaft
9	Spring
10	Drum
11	Fastening Block M5-8
12	Bearing
13	Gasket
14	Screw M5-12
15	Right End Support
16	Laminated Spring
17	Knob
18	Pin
19	Bolt M6-16
20	Bolt M6-16
21	Bolt M8-35
22	Spacer 8 mm
23	Shim 8 mm
24	Screw M8 mm
25	Manual Handle
26	Remote Control
27	Wire Rope and Hook Assy.

NOTE: Some parts are listed and shown for illustration purposes only and are not available individually as replacement parts.

Assembly Drawing

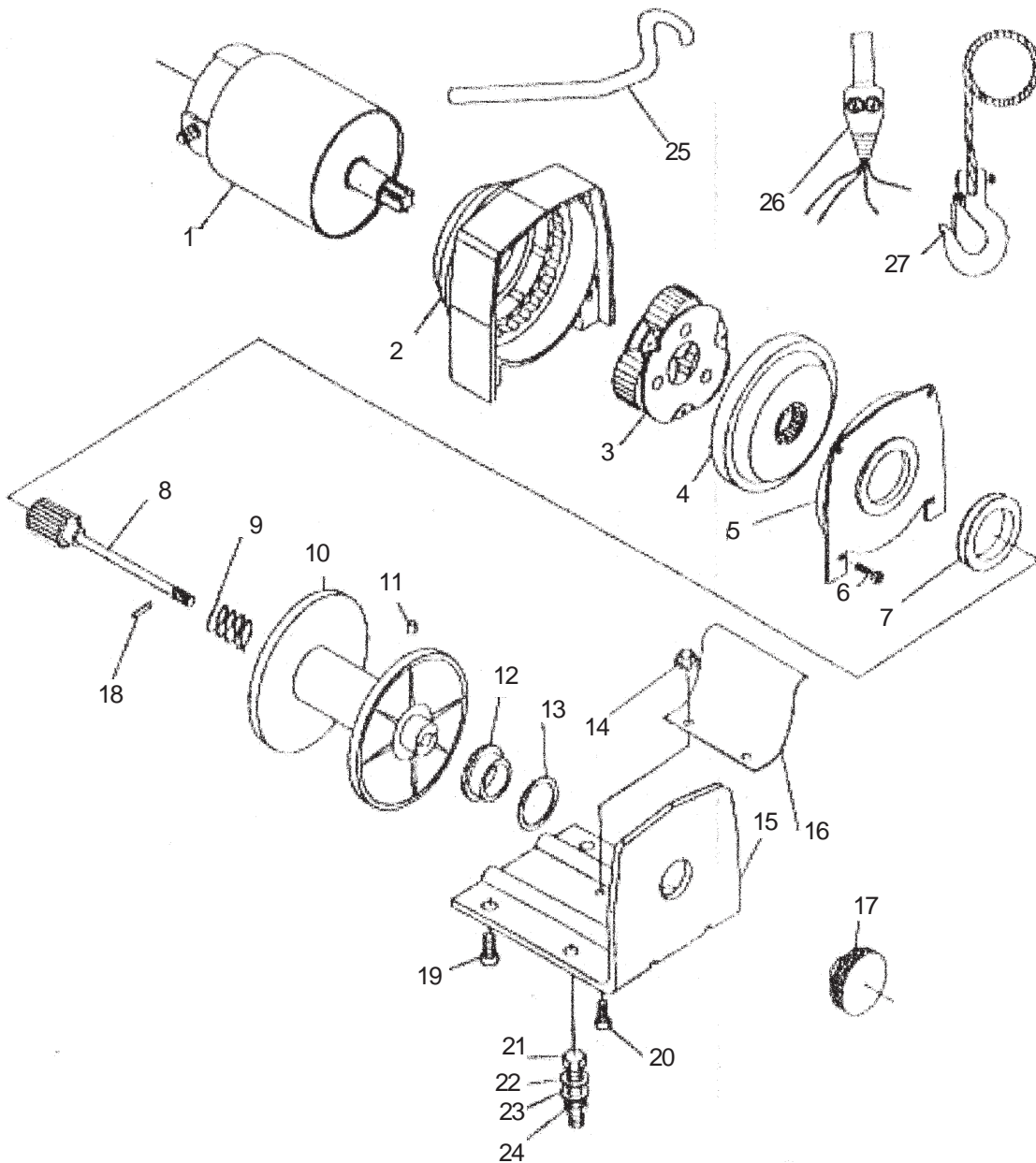

PLEASE READ THE FOLLOWING CAREFULLY

THE MANUFACTURER AND/OR DISTRIBUTOR HAS PROVIDED THE PARTS DIAGRAM IN THIS MANUAL AS A REFERENCE TOOL ONLY. NEITHER THE MANUFACTURER NOR DISTRIBUTOR MAKES ANY REPRESENTATION OR WARRANTY OF ANY KIND TO THE BUYER THAT HE OR SHE IS QUALIFIED TO MAKE ANY REPAIRS TO THE PRODUCT OR THAT HE OR SHE IS QUALIFIED TO REPLACE ANY PARTS OF THE PRODUCT. IN FACT, THE MANUFACTURER AND/OR DISTRIBUTOR EXPRESSLY STATES THAT ALL REPAIRS AND PARTS REPLACEMENTS SHOULD BE UNDERTAKEN BY CERTIFIED AND LICENSED TECHNICIANS AND NOT BY THE BUYER. THE BUYER ASSUMES ALL RISK AND LIABILITY ARISING OUT OF HIS OR HER REPAIRS TO THE ORIGINAL PRODUCT OR REPLACEMENT PARTS THERETO, OR ARISING OUT OF HIS OR HER INSTALLATION OF REPLACEMENT PARTS THERETO.

Free Manuals Download Website

<http://myh66.com>

<http://usermanuals.us>

<http://www.somanuals.com>

<http://www.4manuals.cc>

<http://www.manual-lib.com>

<http://www.404manual.com>

<http://www.luxmanual.com>

<http://aubethermostatmanual.com>

Golf course search by state

<http://golfingnear.com>

Email search by domain

<http://emailbydomain.com>

Auto manuals search

<http://auto.somanuals.com>

TV manuals search

<http://tv.somanuals.com>