

INSTALLATION INSTRUCTIONS

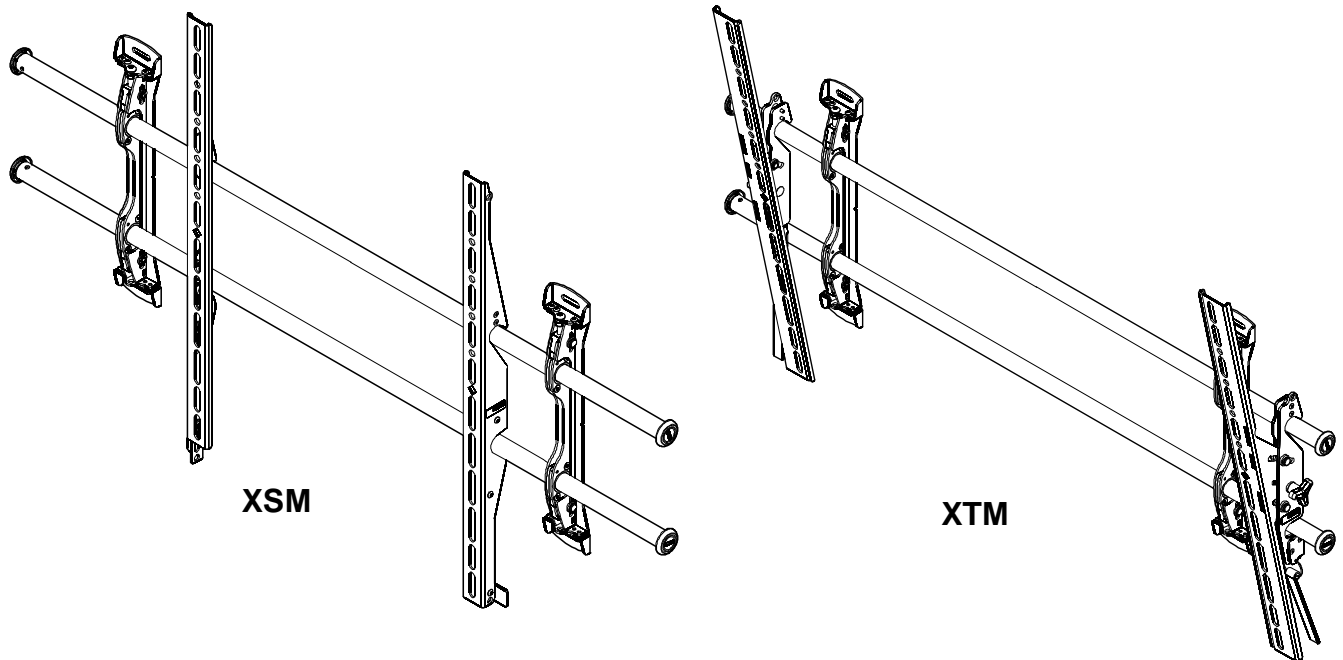

FUSION EXTRA LARGE HEIGHT ADJUST FLAT PANEL MOUNTS

DISCLAIMER

Milestone AV Technologies, and its affiliated corporations and subsidiaries (collectively "Milestone"), intend to make this manual accurate and complete. However, Milestone makes no claim that the information contained herein covers all details, conditions or variations, nor does it provide for every possible contingency in connection with the installation or use of this product. The information contained in this document is subject to change without notice or obligation of any kind. Milestone makes no representation of warranty, expressed or implied, regarding the information contained herein. Milestone assumes no responsibility for accuracy, completeness or sufficiency of the information contained in this document.

Chief® is a registered trademark of Milestone AV Technologies. All rights reserved.



IMPORTANT WARNINGS AND CAUTIONS!



WARNING: A WARNING alerts you to the possibility of serious injury or death if you do not follow the instructions.



CAUTION: A CAUTION alerts you to the possibility of damage or destruction of equipment if you do not follow the corresponding instructions.



WARNING: Failure to read, thoroughly understand, and follow all instructions can result in serious personal injury, damage to equipment, or voiding of factory warranty! It is the installer's responsibility to make sure all components are properly assembled and installed using the instructions provided.



WARNING: Failure to provide adequate structural strength for this component can result in serious personal injury or damage to equipment! It is the installer's responsibility to make sure the structure to which this component is attached can support five times the combined weight of all equipment. Reinforce the structure as required before installing the component.







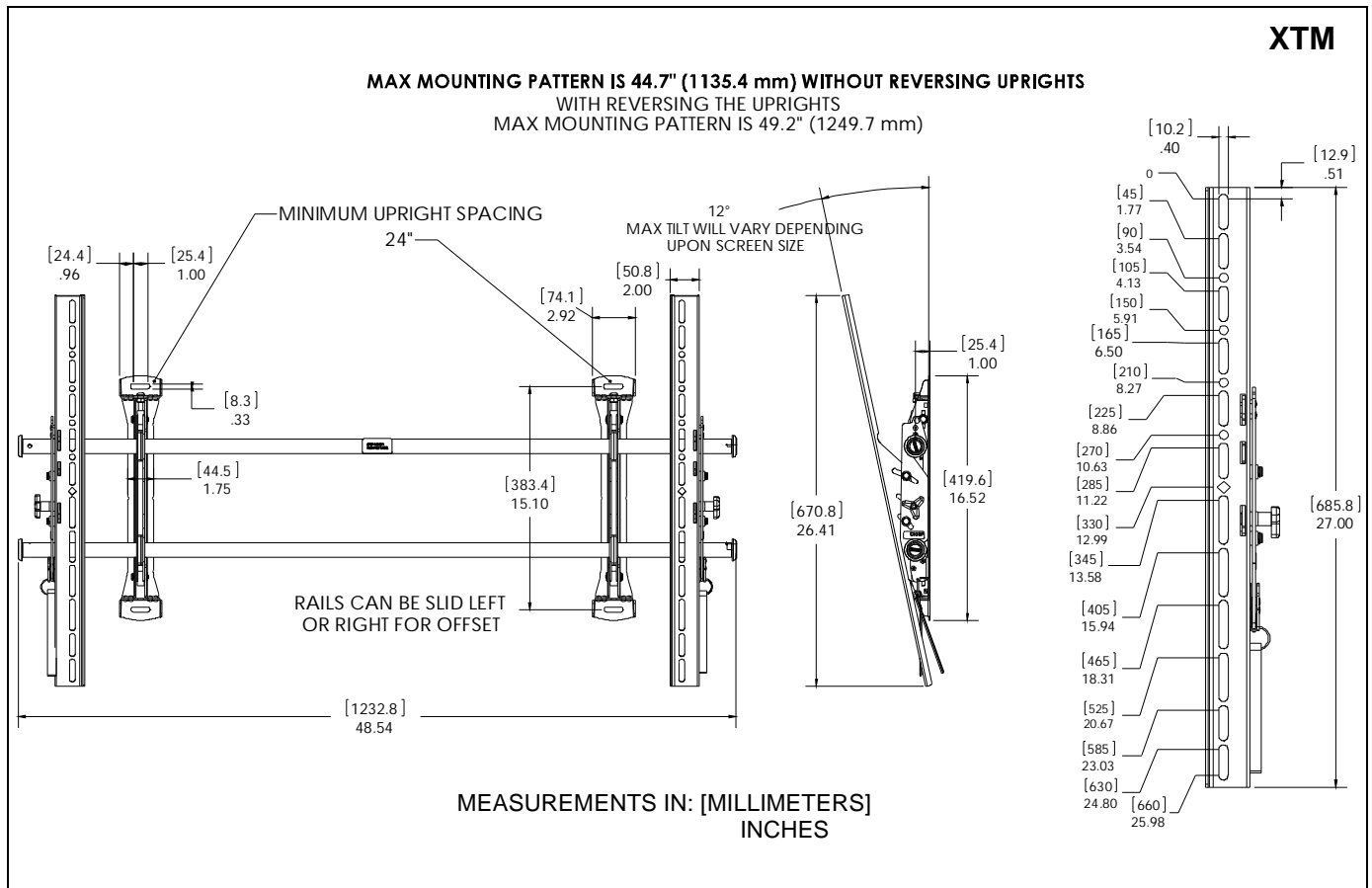
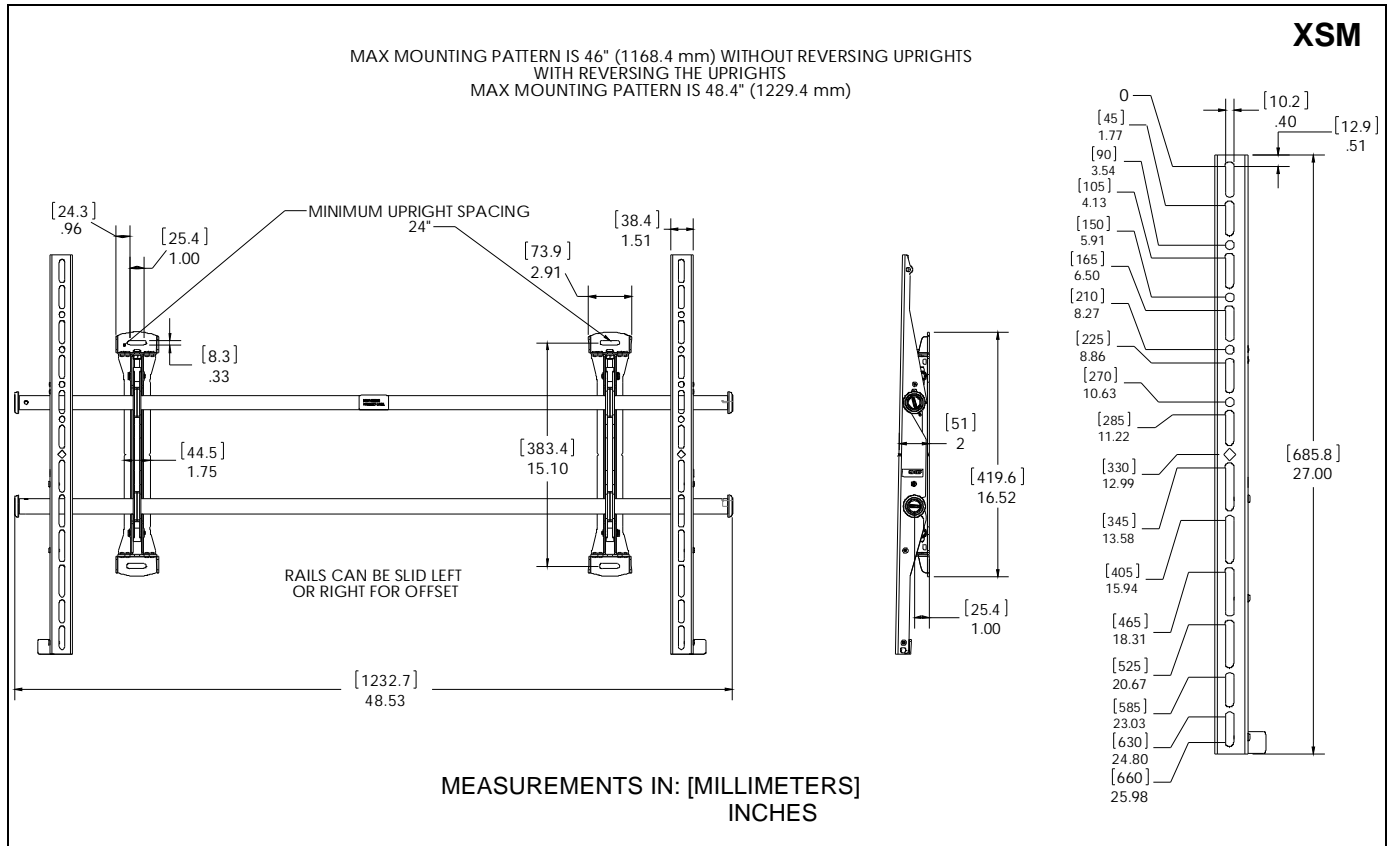



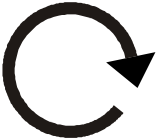

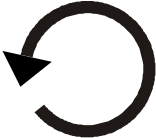

WARNING: Exceeding the weight capacity can result in serious personal injury or damage to equipment! It is the installer's responsibility to make sure the combined weight of all components attached to the XSM/XTM up to (and including) the display does not exceed 250 lbs (113.4 kg).

DIMENSIONS



LEGEND

	Tighten Fastener Apretar elemento de fijación Befestigungsteil festziehen Apertar fixador Serrare il fissaggio Bevestiging vastdraaien Serrez les fixations		Pencil Mark Marcar con lápiz Stiftmarkierung Marcar com lápis Segno a matita Potloodmerkteken Marquage au crayon
	Loosen Fastener Aflojar elemento de fijación Befestigungsteil lösen Desapertar fixador Allentare il fissaggio Bevestiging losdraaien Desserrez les fixations		Drill Hole Perforar Bohrloch Fazer furo Praticare un foro Gat boren Percez un trou
	Phillips Screwdriver Destornillador Phillips Kreuzschlitzschraubendreher Chave de fendas Phillips Cacciavite a stella Kruiskopschroevendraaier Tournevis à pointe cruciforme		Adjust Ajustar Einstellen Ajustar Regolare Afstellen Ajuster
	Open-Ended Wrench Llave de boca Gabelschlüssel Chave de bocas Chiave a punte aperte Steeksleutel Clé à fourche		Remove Quitar Entfernen Remover Rimuovere Verwijderen Retirez
	By Hand A mano Von Hand Com a mão A mano Met de hand À la main		Optional Opcional Optional Opcional Opzionale Optie En option
	Hex-Head Wrench Llave de cabeza hexagonal Sechskantschlüssel Chave de cabeça sextavada Chiave esagonale Zeskantsleutel Clé à tête hexagonale		Security Wrench Llave de seguridad Sicherheitsschlüssel Chave de segurança Chiave di sicurezza Veiligheidsleutel Clé de sécurité

TOOLS REQUIRED FOR INSTALLATION

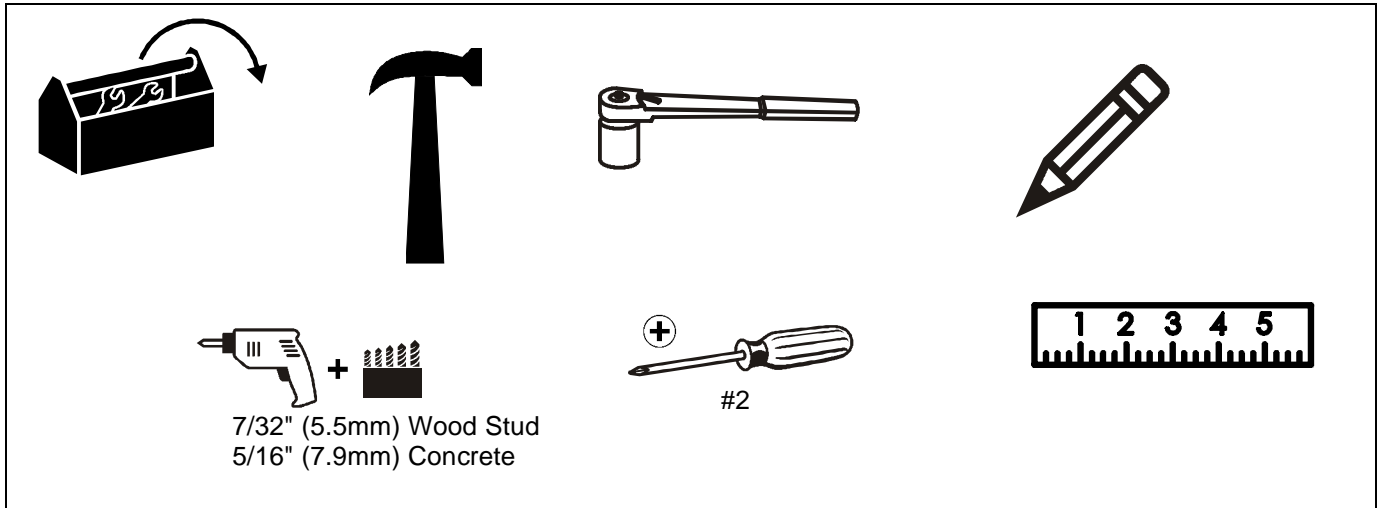

PARTS

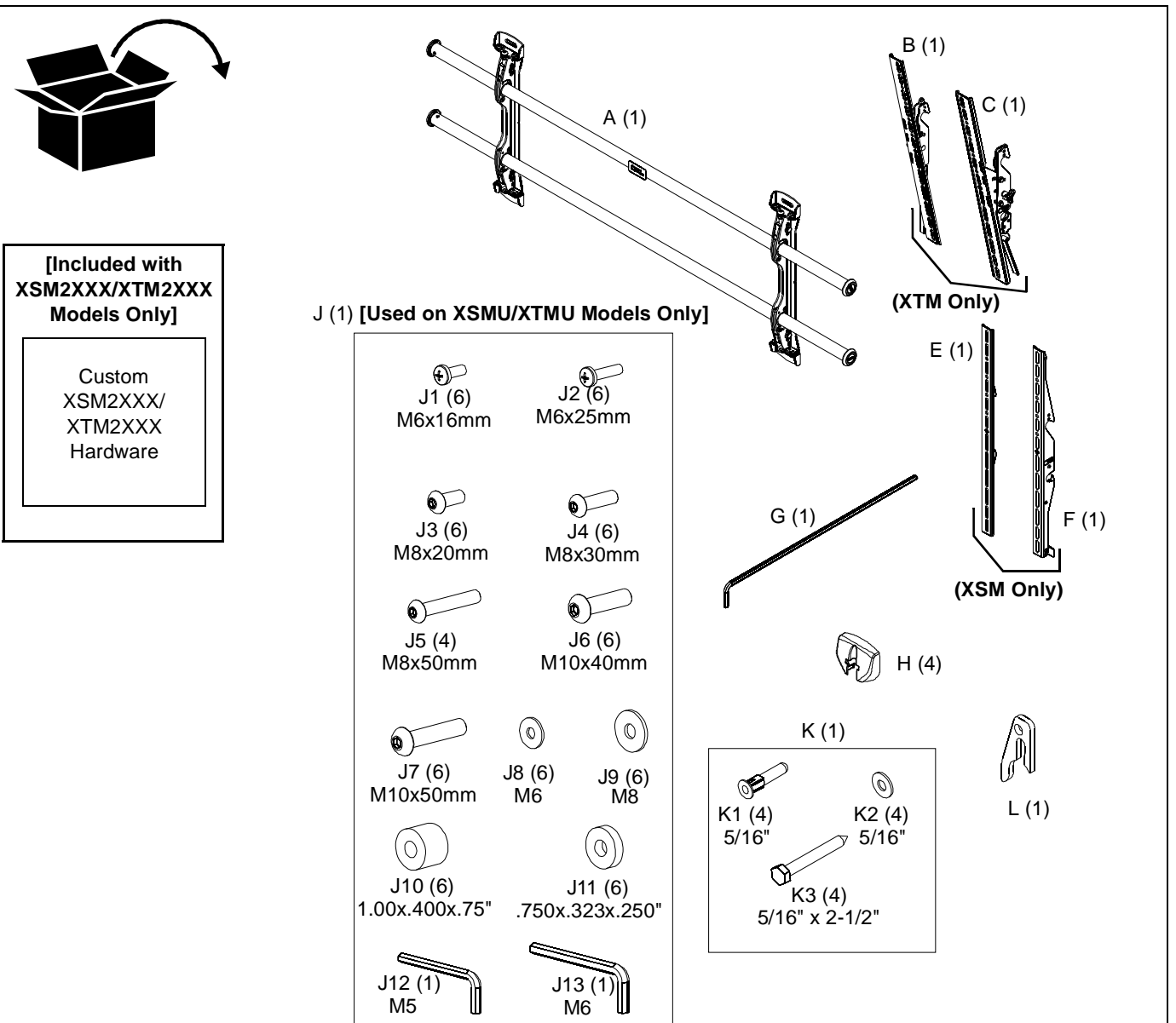

INSTALLATION

The XTM and XSM have been designed to be mounted directly onto either a wood stud or concrete wall. The XTM has brackets which allow the display to be tilted. The XSM has static brackets which keep the display in an upright position.

Locate Mounting Site



WARNING: IMPROPER INSTALLATION CAN LEAD TO MOUNT FALLING CAUSING SEVERE PERSONAL INJURY OR DAMAGE TO EQUIPMENT! It is the installers responsibility to make certain the structure to which the mount is being attached is capable of supporting five times the weight of the XTM or XSM and all attached equipment not to exceed 250 lbs (113.4 kg).

NOTE: Proceed to either the **Installing to a Wood Stud Wall** section or the **Installing to a Concrete Wall** section.

Installing to a Wood Stud Wall



CAUTION: MINIMUM HORIZONTAL DISTANCE BETWEEN WALL BRACKETS IS 24". Do not place mounting brackets closer together than 24". When attaching to a wall containing studs located 16" on center, space the uprights 32" apart.

1. Determine the center of the display, and where it should be located on the wall.
2. Locate the appropriate studs to the left and right of the selected location.

NOTE: If the screen area lies over a stud, use that stud and an appropriate stud to either the left or right of it.

3. Line up the notches on mount with center of screen marking to determine vertical center. (See Figure 1)
4. Measure up 7-1/2" from the center point to mark location of the upper mounting slots.

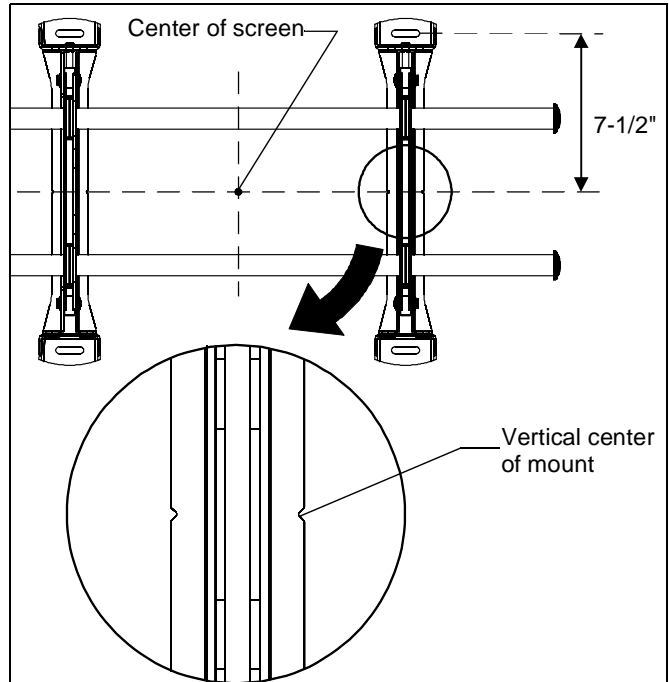

Figure 1

5. Using a level, mark the wall on each stud to attach the mount through the upper mounting slots. (See Figure 2)



WARNING: ELECTRICAL SHOCK HAZARD! CUTTING OR DRILLING INTO ELECTRICAL CORDS OR CABLES CAN CAUSE DEATH OR SERIOUS PERSONAL INJURY! ALWAYS make certain area behind mounting surface is free of electrical wires and cables before drilling or installing fasteners.



WARNING: EXPLOSION AND FIRE HAZARD! CUTTING OR DRILLING INTO GAS PLUMBING CAN CAUSE DEATH OR SERIOUS PERSONAL INJURY! ALWAYS make certain area behind mounting surface is free of gas, water, waste, or any other plumbing before cutting, drilling, or installing fasteners.

6. Drill one 7/32" pilot hole in each stud.
7. Use two 5/16 x 2-1/2" lag bolts (K3) and two 5/16" flat washers (K2) to attach top of mount to wall. (See Figure 2)

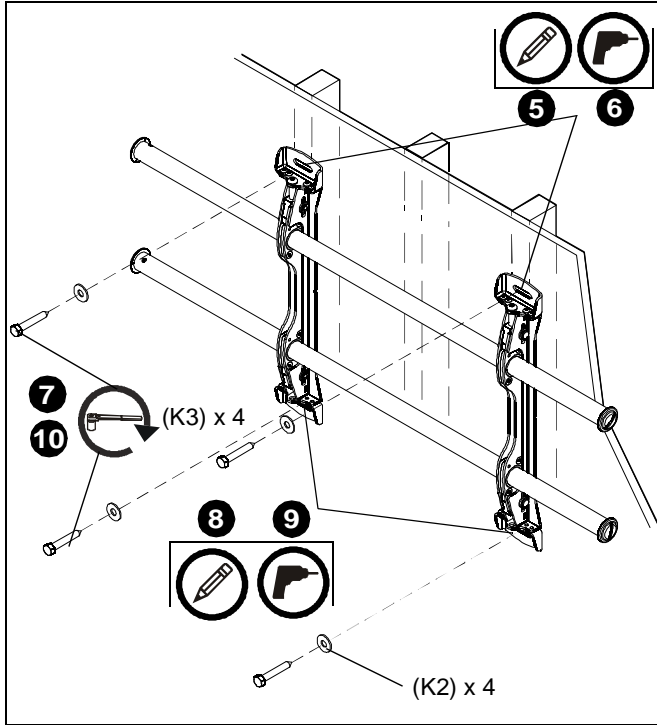

Figure 2

8. Mark the attachment points for the lower mounting slots, making sure the attachment points are located on the studs. (See Figure 2)
9. Drill 7/32" pilot holes at markings for lower mounting holes. (See Figure 2)
10. Use two 5/16 x 2-1/2" lag bolts (K3) and two 5/16" flat washers (K2) to attach the mount to the wall through the lower mounting holes. (See Figure 2)
11. Slide rails to approximate center of screen location.

Installing to a Concrete Wall



CAUTION: MINIMUM HORIZONTAL DISTANCE BETWEEN WALL BRACKETS IS 24". Do not place mounting brackets closer together than 24".

1. Determine the center of the display, and where it should be located on the wall.
2. Line up the notches on mount with center of screen marking to determine vertical center. (See Figure 1)
3. Measure up 7-1/2" from the center point to mark location of the upper mounting slots. (See Figure 1)
4. Using a level, mark the wall through both upper mounting slots. (See Figure 3)



WARNING: ELECTRICAL SHOCK HAZARD! CUTTING OR DRILLING INTO ELECTRICAL CORDS OR CABLES CAN CAUSE DEATH OR SERIOUS PERSONAL INJURY! ALWAYS make certain area behind mounting surface is free of electrical wires and cables before drilling or installing fasteners.



WARNING: EXPLOSION AND FIRE HAZARD! CUTTING OR DRILLING INTO GAS PLUMBING CAN CAUSE DEATH OR SERIOUS PERSONAL INJURY! ALWAYS make certain area behind mounting surface is free of gas, water, waste, or any other plumbing before cutting, drilling, or installing fasteners.

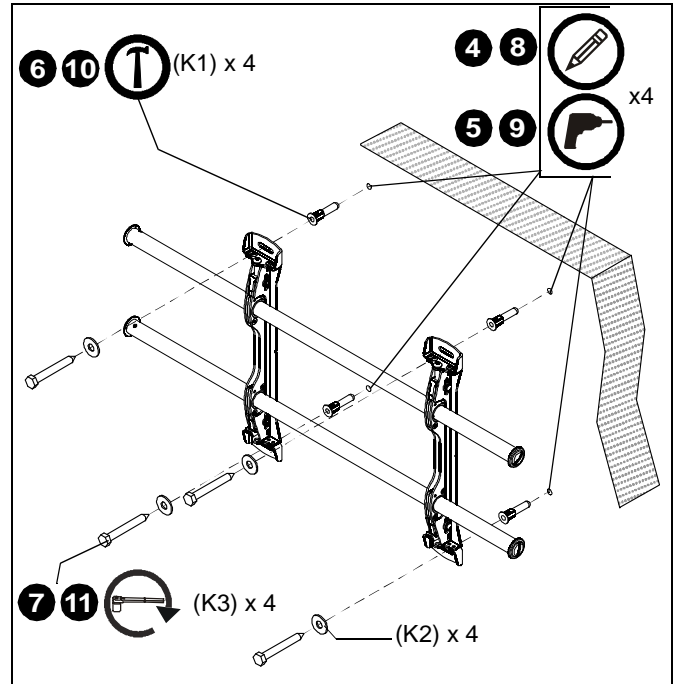

Figure 3

5. Drill one 5/16" pilot hole at each marking.
6. Install an anchor (K1) into each pilot hole using a hammer.
7. Use two 5/16 x 2-1/2" lag bolts (K3) and two 5/16" flat washers (K2) to attach top of mount to anchors in wall.
8. Mark the attachment points for the lower mounting slots. (See Figure 3)
9. Drill one pilot hole at each marking for lower mounting holes. (See Figure 3)
10. Install an anchor (K1) into each pilot hole using a hammer.
11. Use two 5/16 x 2-1/2" lag bolts (K3) and two 5/16" flat washers (K2) to attach the mount to the wall through the lower mounting holes. (See Figure 3)
12. Slide rails to approximate center of screen location.

Attaching Interface Brackets to Display

1. Align the center of the bracket with center of screen. (See Figure 4)

NOTE: The diamond-shape hole in the bracket corresponds to the center of the mount.

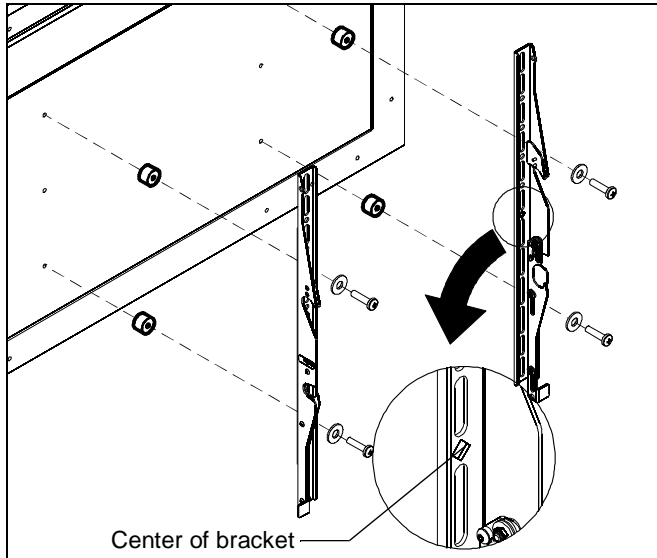

Figure 4



WARNING: IMPROPER INSTALLATION CAN LEAD TO DISPLAY FALLING CAUSING SERIOUS PERSONAL INJURY OR DAMAGE TO EQUIPMENT! Using screws of improper size may damage your display. Properly sized screws will easily and completely thread into display mounting holes. If spacers are required, be sure to use longer screws of the same diameter.

2. Select correct screws, spacers (if necessary) and washers from the hardware bag and attach brackets to back of screen. (See Figure 4)

Switching Interface Brackets (Optional)

If an installation situation makes adjusting the location of interface brackets necessary, there are several options.

1. The wall brackets may be adjusted side to side at the point of attachment. (See Figure 5)
2. The location of the left and right interface brackets may be switched, with the knobs on the XTM interface brackets facing the inside of the mount. (See Figure 5)

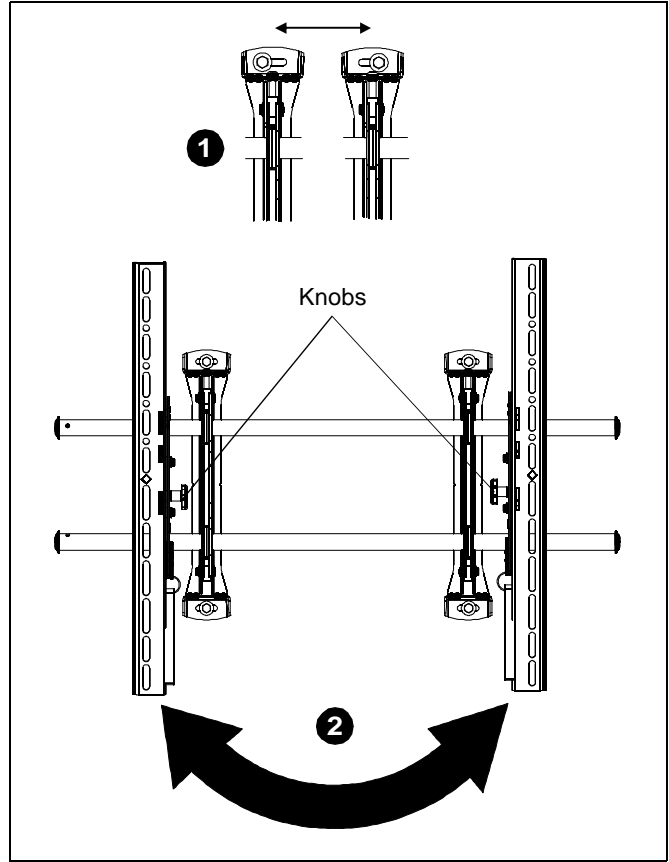

Figure 5

3. If necessary, the tilt interface bracket knobs may be switched to allow the interface brackets to be reversed. (See Figure 6)
 - a. Remove display from mount.
 - b. Remove interface brackets from display.
 - c. Hold the right interface bracket horizontally, tightly gripping it so that spacers do not move.
 - d. Remove the knob, washer and screw.
 - e. Replace the knob, washer and screw in the opposite order, with the knob on the inside of the bracket.
 - f. Switch the right interface bracket to the left side of the wall mount.
 - g. Repeat Steps 3c through 3f with the left interface bracket.

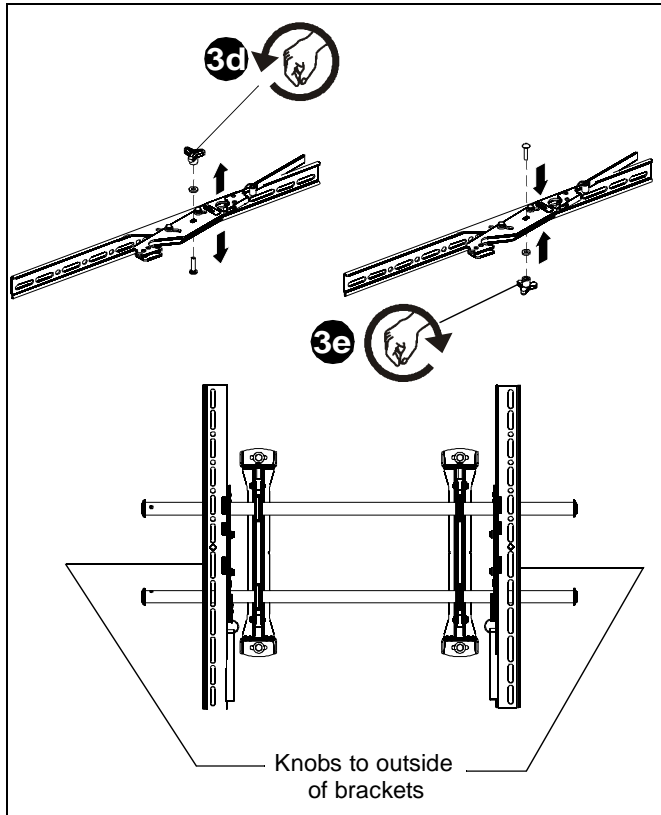

Figure 6

Attaching Screen to Wall Mount

1. Attach wall bracket caps (H) to top and bottom of both wall brackets. (See Figure 7)

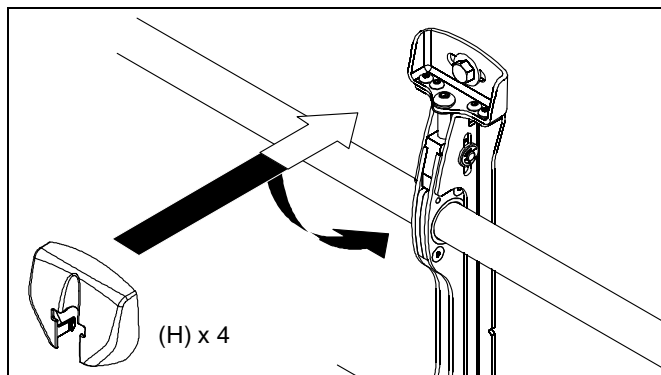

Figure 7

2. Adjust Velcro® pull strap (if necessary) so it does not extend beyond bottom of screen. (See Figure 8)

NOTE: NEVER place both interface brackets to one side of the wall mount center line! (See Figure 8)

NOTE: Do NOT allow both interface brackets to be located on same side of wall bracket. (See Figure 8)

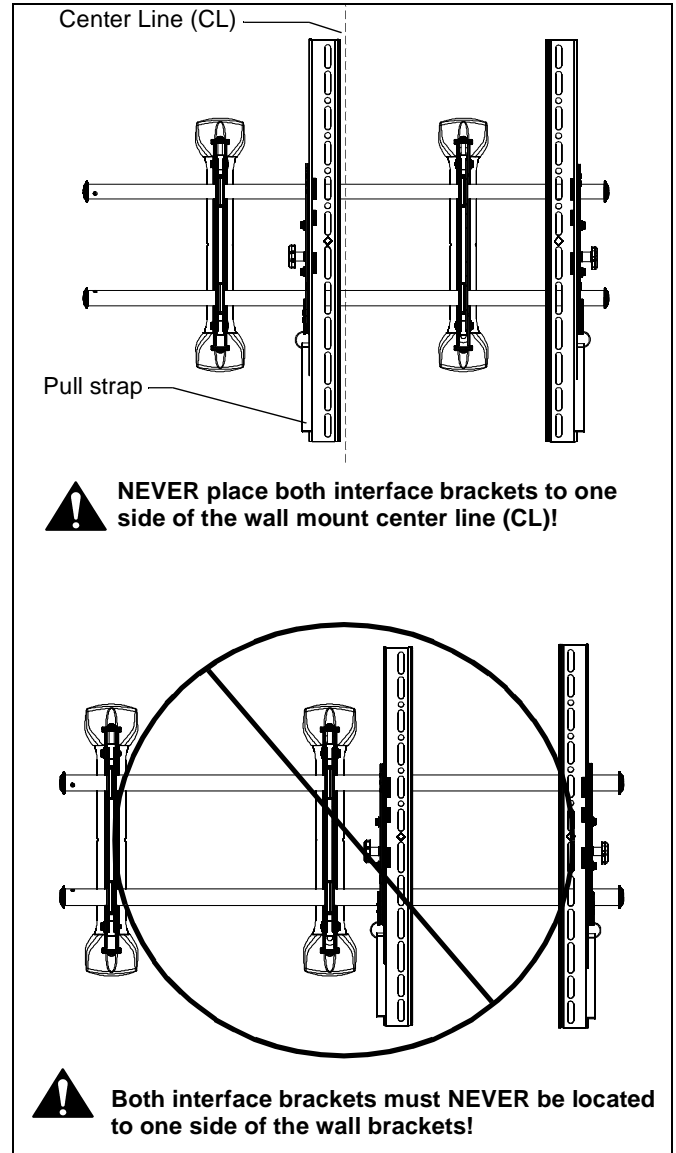

Figure 8

XTM Model

NOTE: Proceed to Step 8 for **XSM Model** instructions.

3. Hang top hook of interface brackets onto the top bar of the mount. (See Figure 9)

NOTE: The screen initially installs into the "kickstand mode" to allow easy cable access.

4. Slide screen and bars to desired viewing position.
5. Route cables between wall and bars.



CAUTION: PINCH POINTS! Keep fingers, hands and cables out of pinch point areas.

6. Pull downward on the pullstraps and swing inward toward wall, latching interface brackets to lower bar and locking bottom of screen to the mount. (See Figure 9)

7. Proceed to **Adjusting Roll/Height of Wall Brackets** section.

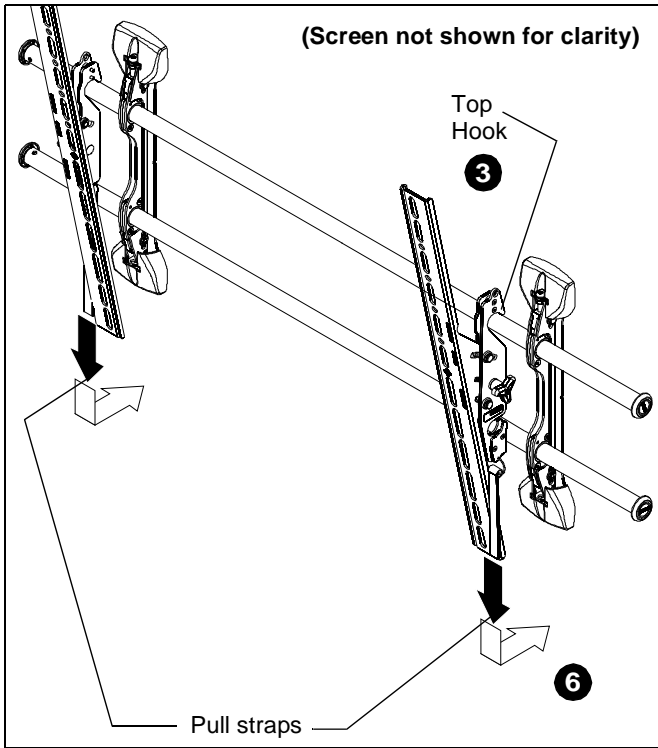

Figure 9

XSM Model

8. Push interface bracket tab all the way down so that the lower mounting slot is blocked. (See Figure 10)

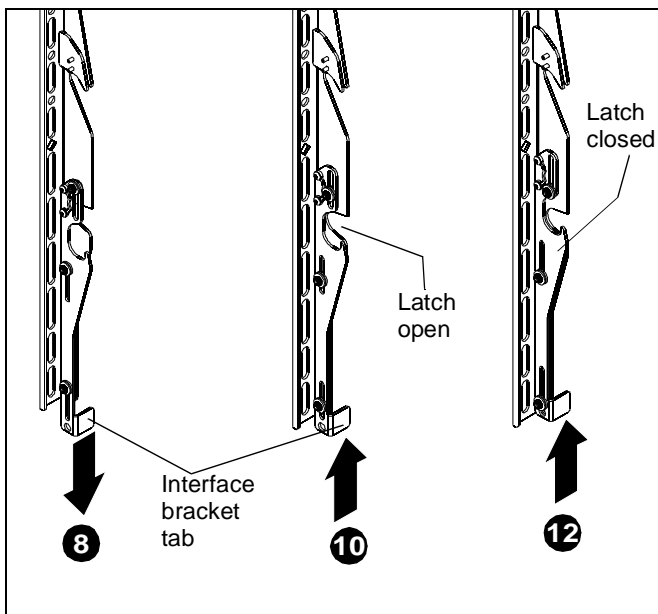

Figure 10

9. Hang the top hook of interface brackets onto the top bar of the mount. The bottom of the screen will be away from the wall.

10. Move screen towards the wall by pulling display bottom away from wall and pushing the interface bracket tabs up one notch to the detent which you will be able to feel (approximately half way up).
11. Push bottom of display toward the wall bracket so that lower latch on interface bracket surrounds lower bar of wall mount.
12. Raise interface brackets tabs all the way to secure the brackets onto the wall mount. (See Figure 10)

Adjusting Roll/Height of Wall Brackets

NOTE: The height adjust wall brackets allow adjustment of $\pm 1/2"$.

1. Turn to right (tighten) to raise side of screen. (See Figure 11)
2. Turn to left (loosen) to lower side of the screen.

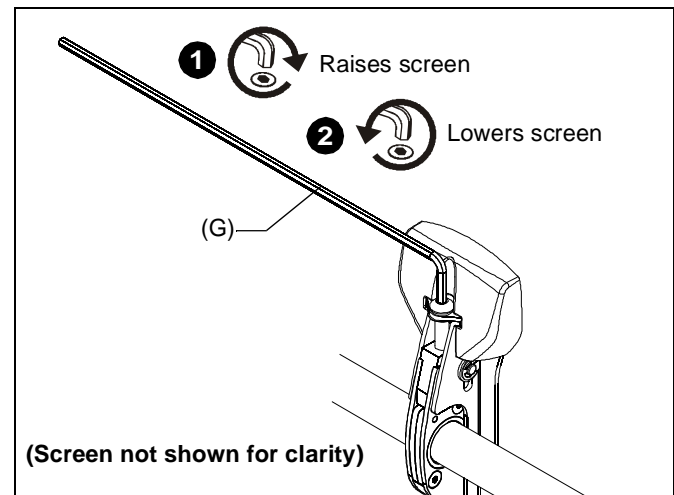

Figure 11

Locking XTM Mount (Optional)

1. Add optional security bracket (L) to the mount. (See Figure 12)
2. Add padlock (not included) to complete security.

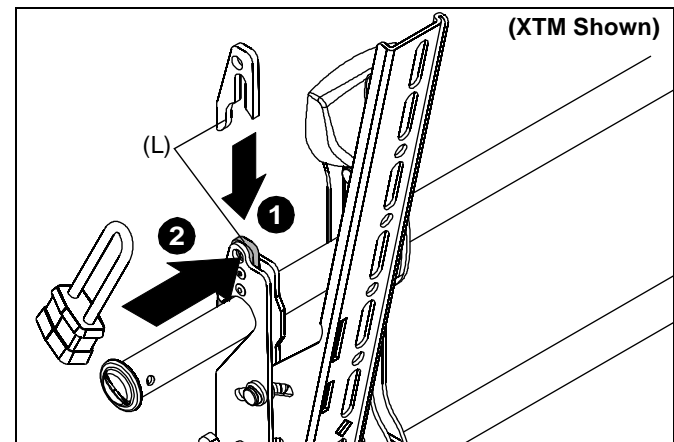

Figure 12

Locking XSM Mount (Optional)

Add padlock (not included) to interface bracket tab to lock the XSM mount. (See Figure 13)

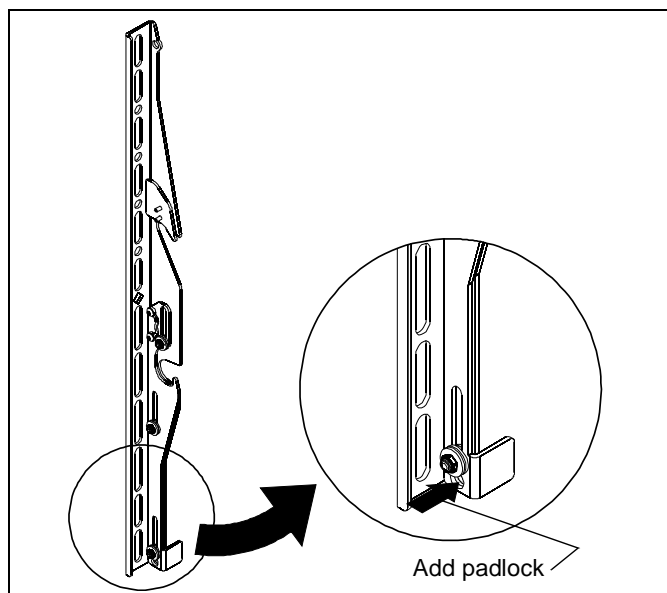

Figure 13



Our Mounts. **Your Vision.**

Chief Manufacturing, a products
division of Milestone AV Technologies

8805-000259

©2008 Milestone AV Technologies,
a Duchossois Group Company
www.chiefmfg.com

11/08

USA/International	A 8401 Eagle Creek Parkway, Savage, MN 55378 P 800.582.6480 / 952.894.6280 F 877.894.6918 / 952.894.6918
Europe	A Fellenoord 130 5611 ZB EINDHOVEN, The Netherlands P +31 (0)40 2668620 F +31 (0)40 2668615
Asia Pacific	A Room 24F, Block D, Lily YinDu International Building LuoGang, BuJi Town, Shenzhen, CHINA. 深圳市布吉罗岗村百合银都国际大厦D栋24F P +86-755-8996 9226 F +86-755-8996 9217



Free Manuals Download Website

<http://myh66.com>

<http://usermanuals.us>

<http://www.somanuals.com>

<http://www.4manuals.cc>

<http://www.manual-lib.com>

<http://www.404manual.com>

<http://www.luxmanual.com>

<http://aubethermostatmanual.com>

Golf course search by state

<http://golfingnear.com>

Email search by domain

<http://emailbydomain.com>

Auto manuals search

<http://auto.somanuals.com>

TV manuals search

<http://tv.somanuals.com>