

Stacking Frame Installation Instructions

INTRODUCTION

Use the following instructions when installing stacking frames onto the models listed in Table 1. Only use the stacking frame provided by Christie (104-117101-01) to hoist or stack a maximum of three projectors. The stacking frame can also be connected to the integral rigging points on any Roadster/Mirage S+ and Roadster HD12k projectors. For information on the rigging hardware of these models, refer to section 2.2 *Installation Considerations* in the *Roadster S+/HD & Mirage S+ User's Manual*.

Table 1. Projector Models

Projector Model	Model Number
Christie DS+4K	38-DSP104-xx
Christie DS+5K/Kc	38-DSP104-xx/38-DSP104-5x
Christie DS+8K	38-DSP106-xx/38-DSP106-5x
DLV1920-DX	104-017101-xx
DLV1400-DX	38-DSP102-xx
Christie DW3K/Kc	38-DHD103-xx/38-DHD103-5x
Christie DW6K/Kc	38-DHD106-xx/38-DHD106-5x
Christie HD5K	104-006101-xx
Christie HD5Kc	104-007101-xx
Christie HD8K	104-008101-xx
Christie HD8Kc	104-018101-xx
Mirage S+2K	38-DSP102-xx/38-DSP102-5x
Mirage S+4K	38-DSP104-xx/38-DSP104-5x
Mirage S+8K	38-DSP106-XX/38-DSP106-5X
Mirage W3	104-012101-xx
Mirage W6	104-013101-xx
Mirage W8	104-014101-xx
Matrix 4000	38-DSP104--xx
Matrix W4	104-016101-xx

Stacking Frame Installation Instructions

WARNINGS

- ⚠ Christie stacking hardware is required to prevent the top projector from sliding off the stack. Failure to incorporate this hardware may cause injury or death.
- ⚠ This procedure must only be performed by a qualified service technician.
- ⚠ The frame is designed to support a maximum stacking capacity of three projectors. Always stack before hoisting.
- ⚠ Never attempt to physically carry a stack of projectors. Always follow the *Hoisting Procedure*, outlined on *page 6*.
- ⚠ Use metric hardware only. Never force incompatible threads.
- ⚠ Always use all rigging points.
- ⚠ The stacking frame handles have a maximum load capacity of 360 lbs.
- ⚠ The projectors can be stacked and hoisted in either an upright or inverted position. Do not mix orientations in a stack (i.e. inverted and upright).
- ⚠ All rigging must be in compliance with applicable local safety codes.
- ⚠ Only licensed riggers should perform the procedures outlined in this document.



Figure 1. Projector with Stacking Frame

Stacking Frame Installation Instructions

1. Stacking Frame Installation



WARNING

ALWAYS power down and unplug the projector prior to servicing. Wait for the internal cooling fans to stop before unplugging the unit.



WARNING

To avoid possible injury, a minimum of two people are required to complete this procedure.

1. Turn the projector OFF and disconnect the AC power cord after the cooling fans have stopped. Allow the projector to cool for at least 45 minutes.
2. Place the projector into the stacking frame so the cut-outs in the bottom mounting plate of the frame align with the fold mirror and adjustable feet access points on the projector. Refer to Figure 2.
3. Use a 10mm socket wrench to tighten the six (6) M10 bolts securing the mounting plate to the bottom of the projector. Refer to Figure 2.

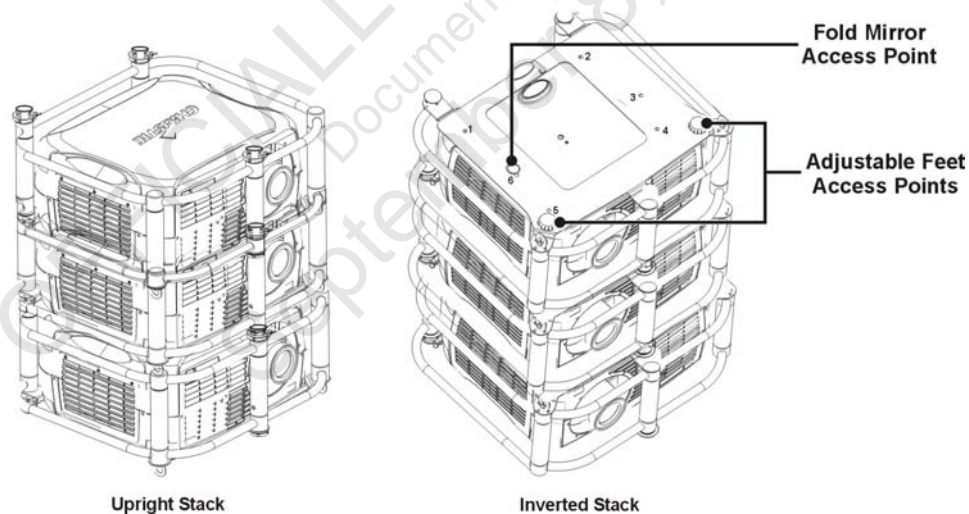

Figure 2. Projector Orientation for Stacking Frame Assembly

Stacking Frame Installation Instructions

2. Stacking Multiple Projectors

WARNINGS

- ⚠ Christie stacking hardware is required to prevent the top projector from sliding off the stack. Failure to incorporate this hardware may cause injury or death.
- ⚠ The frame is designed to support a maximum stacking capacity of three projectors. Always stack before hoisting.
- ⚠ The projectors can be stacked and hoisted in either an upright or inverted position. Do not mix orientations in a stack (i.e. inverted and upright).
- ⚠ Never attempt to physically carry a stack of projectors. Always follow the *Hoisting Procedure*, outlined on page 6.
- ⚠ When hoisting a stack combining Roadster/Mirage S+ and Roadster HD12K models with any of the models listed in Table 1, use the hardware provided with the Roadster/Mirage S+ and Roadster HD12K models to hoist the stack.

1. Place the first projector in the stack on a secure table or cart.

For upright stack: Place the projector to be positioned on the bottom of the stack on the table or cart. Ensure the adjustable feet are **NOT** retracted on the bottom projector. When installing the second and third projector in the stack the feet must be retracted. All projectors must be stacked in the same orientation.

For inverted stack: Place the projector to be positioned on the bottom of the stack on the table or cart. Ensure the adjustable feet **ARE** retracted. Repeat this step when installing a second and third projector. All projectors must be stacked in the same orientation.

2. Turn each stacking leg until at least 1" of thread is visible.

For upright position: Extend the legs of the projector on the top of the stack.

For inverted position: Extend the legs of the projector on the bottom of the stack.

This clearance accommodates the up-or-down movement for image alignment.

Repeat Step 2 when installing a third projector.

IMPORTANT: Ensure all stacking legs are extended equally by at least 1".

Stacking Frame Installation Instructions

3. Loosen the nuts on the rear stacking legs to provide lateral movement for easier alignment with the stacking mounts on the other projector.

For upright position: Release the rear stacking legs on the top projector.

For inverted position: Release the rear stacking legs on the bottom projector.

4. Remove the safety pins from each stacking mount in order to fit the stacking legs into the stacking mounts. Refer to Figure 3.

For upright position: Remove the pins from the mounts on the bottom projector.

For inverted position: Remove the pins from the mounts on the top projector.

5. With one person positioned on each side of the projector, lift the top projector onto the bottom projector, aligning all three stacking points between the projectors. The legs should fit inside the stacking mounts.

6. Turn the adjusting wheel on each stacking mount until the hole in the **top portion** of the mount lines up with the hole in the stacking leg. To make alignment easier insert a screwdriver into one of the holes and use it to align the two holes.



WARNING

Step 7 is a critical safety procedure that must be observed. Failure to engage the safety locks could cause the projectors to separate, resulting in possible injury or death.

7. Insert the safety pin through the holes in the stacking mounts and stacking legs. Ensure each pin is fully inserted to engage the safety lock and secure the projectors. Refer to Figure 3.
8. Before hoisting, firmly tighten the nuts on the two rear stacking legs. If the projectors are ready for image alignment keep the nuts slightly loose until alignment is complete.
9. When required, repeat Steps 1 to 8 for the third projector.









Figure 3. Stacking Mount Components

Stacking Frame Installation Instructions

HOISTING PROCEDURE

WARNINGS

-  Remove the projector lens before hoisting.
-  The frame is designed to support a maximum stacking capacity of three projectors. Always stack before hoisting.
-  All rigging must be in compliance with applicable local safety codes.
-  Only licensed riggers should perform the following procedures.
-  Use metric hardware only. Never force incompatible threads.
-  Never hoist a projector by its feet or any other component.
-  The projectors can be stacked and hoisted in either an upright or inverted position. Do not mix orientations in a stack (i.e. inverted and upright).

Use this procedure to hoist one projector or a stack of projectors. To hoist a stack, first mount two or three projectors according to the stacking procedure included in these instructions. There are two hoisting techniques available. These two options are used for the various stacking combinations and for the hardware options available. These options include, hoisting via the stacking frame handles or hoisting via the hardware on Roadster/Mirage S+ and Roadster HD12K models.

Key Points:

- When hoisting a stack combining Roadster/Mirage S+ and Roadster HD12K models with any of the models listed in Table 1, use the hardware provided with the Roadster/Mirage S+ and Roadster HD12K models to hoist the stack.
- When hoisting via the stacking frame handles leave a 150mm space between the rigging hardware.
- Connect safety cables and rigging equipment to the designated locations on the stacking frame.
- Use the two eyebolts on the stacking frame as safety points.
- Use hoisting and rigging equipment suitable to the application; such as clamps, cables, eyebolts, or straps that accommodate the load rating. All integral, metric hardware on the rigging hardware accepts an M12 thread only.

Stacking Frame Installation Instructions

HOISTING VIA STACKING FRAME HANDLES



WARNING

When hoisting via the stacking frame handles it is mandatory to use at least four rigging points (two opposite sides). Straps must be placed on either side of designated label on the stacking frame handles.

1. If the projector is inverted retract the adjustable feet to prevent the hoisting hardware from becoming snagged.



WARNING

Always use at least two safety cables when hoisting and attach them to the two eyebolts on the stacking frame.

2. Attach a safety cable to at least of the eyebolts mounted on the bottom of the stacking frame.
3. Secure the rigging components to the appropriate rigging points. Refer to the designated labels on the stacking frame handles for rigging positions.
4. It is mandatory to use four rigging points. Ensure the straps, clamps or cabling meet the adequate load capacity for the total projector(s) weight. **DO NOT** join the rigging straps or cables to a common point – keep separated. Refer to Figure 4.

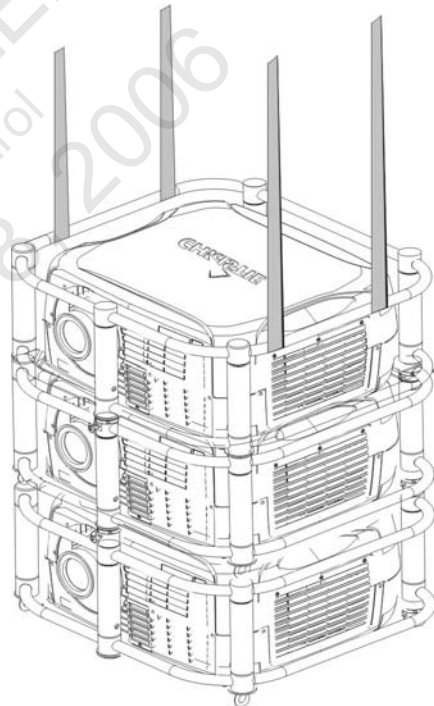

Figure 4. Four Rigging Points

Stacking Frame Installation Instructions

HOISTING VIA ROADSTER/MIRAGE S+/ROADSTER HD 12K HARDWARE



WARNING

When hoisting a stack combining Roadster/Mirage S+ and Roadster HD12K models with any of the models listed in Table 1 use the hardware on the Roadster/Mirage S+ and Roadster HD12K models to hoist the stack.



WARNING

The four top rigging points have a maximum loading capacity of 800 lbs. each. When hoisting from the bottom of the projector use at least four of the eight rigging points (two opposite sets). Use metric hardware only (M12 thread).

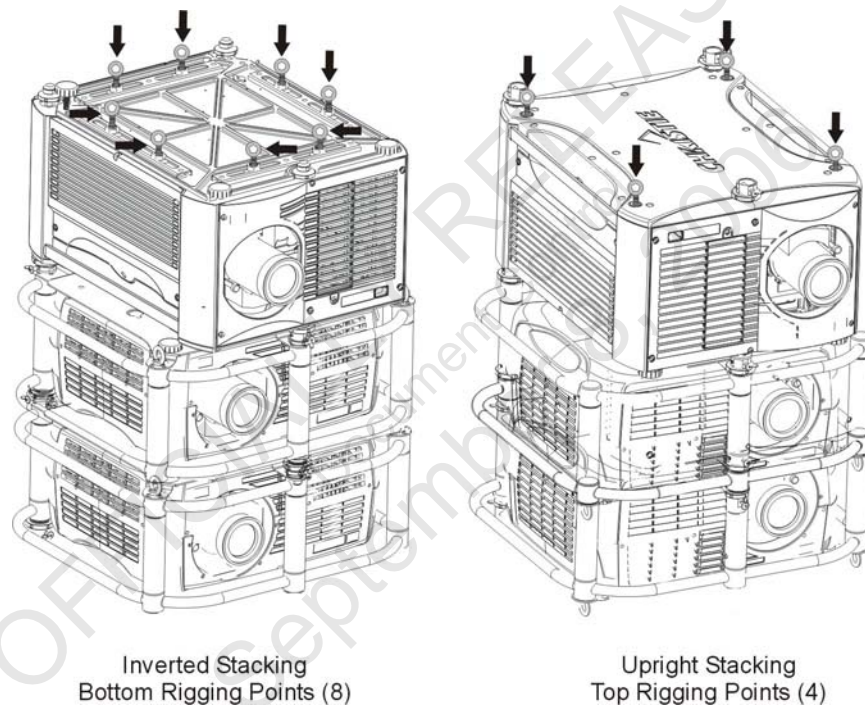

Figure 5. Hoisting via Roadster/Mirage S+/Roadster HD12K Hardware

Stacking Frame Installation Instructions

1. If the projector is inverted retract the adjustable feet to prevent the hoisting hardware from becoming snagged.



WARNING

Always use at least two safety cables when hoisting.



When hoisting a non-inverted projector or stack, add two rigging eyebolts in the front and rear threaded holes on the top of the projector. Ensure the eyebolts are rated adequately for the load. Secure safety cabling to both eyebolts.

2. Attach a safety cable to each of the two eyebolts mounted on the bottom of the projector. Refer to Figure 6.
3. Secure the rigging components to the appropriate rigging points. Eight sliding points are provided on the bottom of the projector. To prevent sliding tighten the nut at each required location.
4. Use at least four rigging points (two opposite sides) and ensure the straps, clamps or cabling meet the adequate load capacity for the total projector(s) weight. Refer to *Section 6* of the manual shipped with the projector for information on size and weight. **DO NOT** join the rigging straps or cables to a common point – keep separated. Ensure all straps are taut.

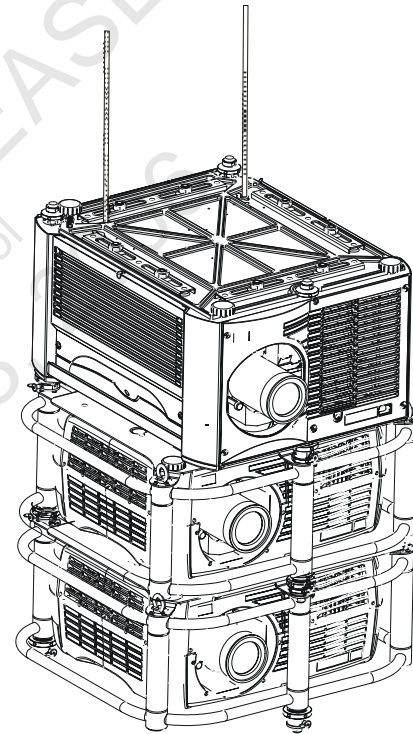



Figure 6. Safety Cables

Stacking Frame Installation Instructions

PROJECTOR ALIGNMENT

 Ensure the stacking legs are extended at least 1" and are slightly loose before aligning the projectors.

Stacked projectors must be correctly aligned to one another so the resulting display is optimized and as sharp as possible. If hoisting the stack do so first and then align. To maintain alignment lock all stacking hardware into place.

- Always align the **fixed** projector. For floor or table-mount (i.e. non-hoisted) stacks, align the bottom projector. In hoisted stacks, align the top projector.
 - Leg nuts must be loosened before alignment; otherwise the stacking mounts will not turn and allow movement of the projector.
1. Position the fixed projector's image as desired and align the other image(s) to it.
 2. To distinguish between the images, enable Red for one display and Green for the other. For more information, refer to the manual supplied with the projector.
 3. Minimize each projector's zoom until the images are focused.
 4. Adjust the zoom and lens offset on the top projector to precisely move its test pattern display onto the bottom test pattern. When it is properly aligned all the Red/Green grid lines in the combined image will turn Yellow.
 - If all lines are well-aligned, skip to Step 7 to lock all stacking mounts.
 - If alignment needs improvement, proceed to Step 5.
 5. For well-aligned center lines turn the two rear stacking mount wheels to move the top projector. Use a screwdriver in the holes around the rim of each adjusting wheel for better leverage and control. Turned independently, each stacking mount acts as a pivot point for the opposite edge of the display. Refer to Figure 7. For example, turn the right mount to tilt the left portion of the image and turn the left mount to tilt the right portion of the image. Turn the mounts together to raise or lower the top image, or turn the front stacker. If the center lines form an X it indicates the projectors (and images) are slightly tilted in relation to one another. Turn one mount to raise one side, and/or turn the other mount to lower the other side. Refer to Figure 7.

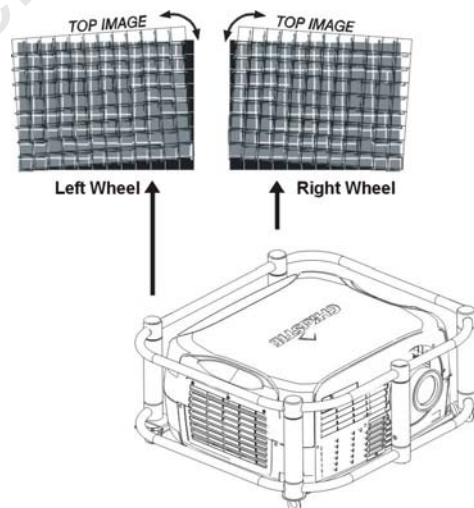

Figure 7. Directional Adjustment (Tilt)

Stacking Frame Installation Instructions

- If centerlines are out by the same amount from top to bottom – use lens offsets (on top projector) to bring the centerlines into alignment. Refer to Figure 8.

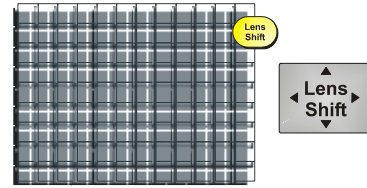

Figure 8. Centerline Alignment

- If centerlines are parallel, but others are not, turn the front stacking mount wheel to bring the centerlines into alignment. Refer to Figure 9.
6. Adjust the zoom on the top projector to align the edges of its image with the other image and then adjust focus. When aligned, all lines from the combined Red/Green grids will be Yellow.

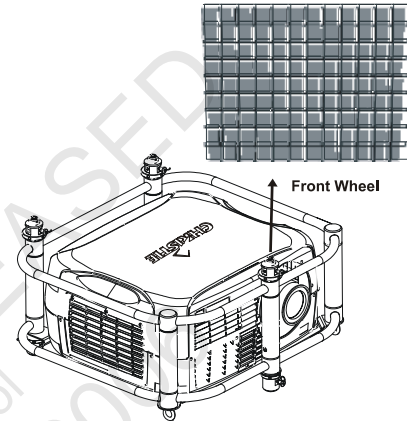

Figure 9. Centerline Alignment

WARNING



Step 7 is a critical safety procedure that must be observed. Failure to properly secure the stacking wheels could cause the projectors to separate, resulting in possible injury or death.

7. Turn all three stacking wheels until they are **firmly secure** against the rest of the stacking mount.
8. Secure both rear leg nuts against the bottom of the projector.
9. Repeat Steps 1-8 when a third projector is used.

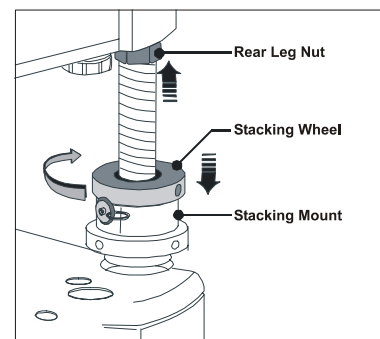

Figure 10. Secure Hardware

Stacking Frame Installation Instructions



NORTH AMERICA

CHRISTIE Digital Systems, Inc.
809 Wellington St. North
Kitchener, Ontario, Canada N2G 4Y7
Tel. 519-744-8005 (General)
Toll Free 1-800-221-8025 (Technical Support)
Fax 519-749-2776 (Service)

CHRISTIE Digital Systems, Inc.
10550 Camden Drive
Cypress, CA 90630 USA
Tel. 714-236-8610 (General)
Toll Free 1-800-221-8025 (Technical Support)
Fax 714-503-3375

EUROPE

CHRISTIE Digital Systems, Inc.
View Point
200 Ashville Way
Wokingham, Berkshire RG41 2PL
United Kingdom
Tel. +44-118-977-8111
Fax +44-118-977-8112

CHRISTIE Digital Systems, Inc.
Willicher Damm 129
D-41061 Mönchengladbach
Germany
Tel. +49-2161-664540
Fax +49-2161-664546

CHRISTIE Digital Systems, Inc.
7, av Georges Pompidou
92593 Levallois-Perret Cedex
France
Tel. +33-(0)1-47-48-28-07
Fax +33-(0)1-47-48-26-06

ASIA-PACIFIC / OTHER

CHRISTIE Digital Systems, Inc.
627A Aljunied Road
05-02 Biz Tech Centre
Singapore 389842
Tel. 65-6877-8737
Fax 65-6877-8747

CHRISTIE Digital Systems, Inc.
Rm. C1109, Orient International Bldg. (Part C)
85 Lou Han Guan Rd.
Shanghai, 200336
People's Republic of China
Tel. +86-21-6278-7708
Fax +86-21-6278-7707

CHRISTIE Sales (Canada)
Tel. 1-800-265-2171
Fax 519-749-3136

CHRISTIE Sales (U.S.)
Tel. 1-800-407-7727 or 1-866-880-4462
Fax 714-503-3375



Free Manuals Download Website

<http://myh66.com>

<http://usermanuals.us>

<http://www.somanuals.com>

<http://www.4manuals.cc>

<http://www.manual-lib.com>

<http://www.404manual.com>

<http://www.luxmanual.com>

<http://aubethermostatmanual.com>

Golf course search by state

<http://golfingnear.com>

Email search by domain

<http://emailbydomain.com>

Auto manuals search

<http://auto.somanuals.com>

TV manuals search

<http://tv.somanuals.com>