

Chromalox®

Installation Instructions

SERVICE REFERENCE

DIVISION 4	SECTION CBH
SALES REFERENCE (Supersedes PB402-3)	PB402-4
161-049132-001	
DATE	MARCH, 1999

Type CBH Electric Stud Heater

Specifications — Table A

Model	Volts	Watts	A Insertion Length	B Heater Length	C Heater Diameter	D Cold End	E Cold End	Max. Stud Hole Diameter*
CBH-1815	120	1150	18"	12"	0.553"	1-1/8"	6-7/8"	0.616
CBH-2415	120	1500	24"	18"	0.553"	1-1/8"	6-7/8"	0.616
CBH-3025	120	2250	30"	24"	0.553"	1-1/8"	6-7/8"	0.616
CBH-3025	240	2250	30"	24"	0.553"	1-1/8"	6-7/8"	0.616
CBH-3625	120	2600	36"	30"	0.553"	1-1/8"	6-7/8"	0.616
CBH-3625	240	2600	36"	30"	0.553"	1-1/8"	6-7/8"	0.616
CBH-1816	120	1200	18"	12"	0.660"	1-1/8"	6-7/8"	0.735
CBH-2416	120	1700	24"	18"	0.660"	1-1/8"	6-7/8"	0.735
CBH-3026	120	2300	30"	24"	0.660"	1-1/8"	6-7/8"	0.735
CBH-3626	120	2800	36"	30"	0.660"	1-1/8"	6-7/8"	0.735
CBH-1827	120	1700	18"	12"	0.730"	1-1/4"	6-3/4"	0.860
CBH-2427	120	2500	24"	18"	0.730"	1-1/4"	6-3/4"	0.860
CBH-3647	120	4200	36"	30"	0.730"	1-1/4"	6-3/4"	0.860
CBH-3647	240	4200	36"	30"	0.730"	1-1/4"	6-3/4"	0.860
CBH-4867	240	6000	48"	42"	0.730"	1-1/4"	6-3/4"	0.860
CBH-4867	480	6000	48"	42"	0.730"	1-1/4"	6-3/4"	0.860
CBH-6177	240	7500	60"	54"	0.730"	1-1/4"	6-3/4"	0.860
CBH-2438	240	2700	24"	18"	0.855"	1-1/4"	6-3/4"	0.985
CBH-3048	120	3600	30"	24"	0.855"	1-1/4"	6-3/4"	0.985
CBH-4258	240	5300	42"	36"	0.855"	1-1/4"	6-3/4"	0.985
CBH-4258	480	5300	42"	36"	0.855"	1-1/4"	6-3/4"	0.985
CBH-4868	240	6500	48"	42"	0.855"	1-1/4"	6-3/4"	0.985
CBH-4269	240	6000	42"	36"	0.980"	1-1/4"	6-3/4"	1.110
CBH-4269	480	6000	42"	36"	0.980"	1-1/4"	6-3/4"	1.110
CBH-6189	240	8000	54"	48"	0.980"	1-1/4"	6-3/4"	1.110
CBH-6619	480	9000	66"	60"	0.980"	1-1/4"	6-3/4"	1.110
CBH-6011	480	11500	60"	54"	1.106"	1-1/4"	6-3/4"	1.236

* Stud Hole Diameter should be held closer to the heater diameter, if possible. Consult factory for use of heaters in stud hole diameters not listed in Specifications.

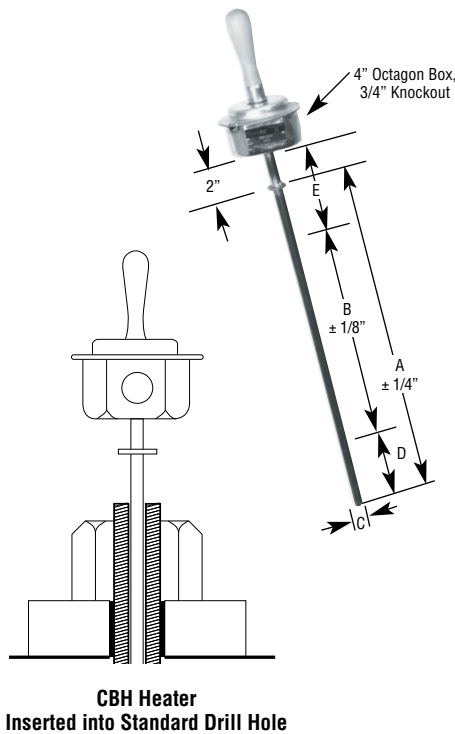

GENERAL

WARNING: This heater is not intended for use in hazardous atmospheres where flammable vapors, gases, liquids or other combustible atmospheres are present as defined in the National Electrical Code. Failure to comply can result in explosion or fire.

The Chromalox electric stud heaters are ruggedly constructed and if properly installed, operated and maintained, will provide long life and dependable, trouble-free service.

Since excess temperatures may permanently damage the heaters, temperature regulating and limiting controls are recommended.

WARNING: Users should install adequate back-up controls and safety devices with their electric heating equipment. Where the consequences of failure may be severe, back-up controls are essential. Although the safety of the installation is the responsibility of the user, Chromalox will be glad to make equipment recommendations.

INSTALLATION

WARNING: Hazard of Electric Shock. Disconnect all power before installing heater.

1. Select the heater with the proper diameter and insertion length closest to the size hole in the stud or bolt being heated. The heated section must be inserted in the stud when energized. Insert the entire heated length of heater into stud hole.

WARNING: Stud hole must not be larger for heater being used than that shown in Table A Specifications.

A stud hole five thousandths larger than specified will cause premature burnout or permanent damage to heater.

2. Graphite and other lubricants to help insert the cartridge heater into the hole are not recommended. They are electrically conductive and can contaminate the heater and shorten heater life. Chromalox HTRC (Heat Transfer and Release Coating) is recommended.

INSTALLATION

WARNING: Never hammer the heater ends.

3. **DANGER: Hazard of Fire.** Since these heaters are capable of developing high temperatures, extreme care should be taken to:
- Avoid mounting heaters in an atmosphere containing combustible gases and vapors.

- Avoid contact between heaters and combustible materials.
- Keep combustible materials far enough away to be free of the effects of high temperatures.

WIRING

WARNING: Hazard of Electrical Shock. Any installation involving electric heaters must be effectively grounded in accordance with the National Electrical Code to eliminate shock hazard.

- Electric wiring to heating elements must be installed in accordance with National Electrical Code and local codes by a qualified person. Use copper conductors only.
- Protection with properly sized fuses/breakers is important to minimize hazards.

OPERATION

- Do not operate heaters at voltages in excess of that stamped on the heater since excess voltage will shorten heater life.
- Do not operate under conditions that result in temperatures higher than the recommended maximum, since excess temperatures can cause premature heater failure.

The maximum recommended temperature on sheath materials normally supplied is:

Stainless Steel	— 1200°F
Alloy	— 1600°F

- Electrical terminals should be protected from spillage of plastics, water, oil and their vapors which can create electrical hazards and/or heater failure.
- Do not energize heater in free air or at more than rated voltage.
- Stud heaters are generally used in large banks to allow uniform tightening of mating parts. All heaters of one group should be energized simultaneously.

MAINTENANCE

WARNING: Hazard of Severe Shock. Disconnect all power to heaters before servicing or replacing heaters.

- Make certain that both the terminals and heater sheath are free from contact with oil, liquids or other foreign matter.

NOTE: Chromalox cannot be responsible for failures or damage caused by organic contamination in stud heaters. Make certain that the heaters are not exposed to organic contaminants.

- Check electrical connections at heater terminals and tighten if necessary. This will help avoid hot terminals that may destroy wire insulation or heater terminals.
- Check overheat operation to insure heater protection.
- REPAIR** — For *In-Warranty* repair, please follow instructions in warranty below.

WARNING: Out-of-Warranty repairs should only be attempted by qualified personnel.

Limited Warranty:

Please refer to the Chromalox limited warranty applicable to this product at <http://www.chromalox.com/customer-service/policies/termsofsale.aspx>.

Chromalox[®]
PRECISION HEAT AND CONTROL

2150 N. RULON WHITE BLVD., OGDEN, UT 84404
Phone: 1-800-368-2493 www.chromalox.com

Download from www.Somanuals.com. All Manuals Search And Download.

Free Manuals Download Website

<http://myh66.com>

<http://usermanuals.us>

<http://www.somanuals.com>

<http://www.4manuals.cc>

<http://www.manual-lib.com>

<http://www.404manual.com>

<http://www.luxmanual.com>

<http://aubethermostatmanual.com>

Golf course search by state

<http://golfingnear.com>

Email search by domain

<http://emailbydomain.com>

Auto manuals search

<http://auto.somanuals.com>

TV manuals search

<http://tv.somanuals.com>