

Chromalox®

Installation, Operation and RENEWAL PARTS IDENTIFICATION

SERVICE REFERENCE

DIVISION 4	SECTION U-RAD
SALES REFERENCE (Supersedes PG405-4)	PG405-5
161-048457-001	
DATE	APRIL, 2005

Type U-RAD Electric Radiant Heaters

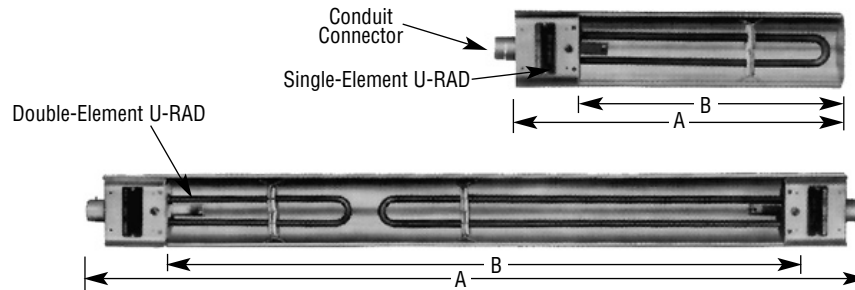

The Safety Alert Symbol  is used to indicate a risk of personal injury.

Please familiarize yourself with these instructions before attempting to install or operate this Radiant Heater.

Before Installing

1. Open carton and remove heater at the place of installation. Mounting clamps are in parts bag in carton.
2. Check nameplate volt and watt rating against your power supply voltage and heating requirements of your installation. This nameplate is located on one end of the heater.

WARNING

The system designer is responsible for the safety of this equipment and should install adequate back-up controls and safety devices with their electric heating equipment. Where the consequences of failure could result in personal injury or property damage, back-up controls are essential.

Specifications Table -

Model	Volts	kW	Length (In.)	
			Overall	Heated
Single U-Shaped Element				
U-RAD-2	120 or 240	800	12-3/4	8-5/16
U-RAD-2V	208 or 275			
U-RAD-3	120 or 240	1100	15-7/8	11-7/16
U-RAD-3V	208 or 275			
U-RAD-4V	208 or 275	1800	23-13/16	19-3/8
U-RAD-4	240 or 480			
U-RAD-5V	208 or 275	2500	31-1/4	26-13/16
U-RAD-5	240 or 480			
U-RAD-6V	208 or 275	3000	37-1/4	32-13/16
U-RAD-6	240 or 480			
U-RAD-7V	208 or 275	3600	43-3/8	38-15/16
U-RAD-7	240 or 480			

Model	Volts	kW	Length (In.)	
			Overall	Heated
Two U-Shaped Elements				
U-RAD-22	120 or 240	1600	25-1/2	16-5/8
U-RAD-22V	208 or 275			
U-RAD-32	120 or 240	1900	28-5/8	19-3/4
U-RAD-32V	208 or 275			
U-RAD-33	120 or 240	2200	31-3/4	22-7/8
U-RAD-33V	208 or 275			
U-RAD-42V	208 or 275	2600	36-9/16	27-11/16
U-RAD-42	240			
U-RAD-43V	208 or 275	2900	39-11/16	30-13/16
U-RAD-43	240			
U-RAD-44V	208 or 275	3600	47-9/16	38-11/16
U-RAD-44	240			
U-RAD-52V	208 or 275	3300	44	35-1/8
U-RAD-52	240			
U-RAD-53V	208 or 275	3600	47-1/8	38-1/4
U-RAD-53	240			
U-RAD-54V	208 or 275	4300	55-1/16	46-3/16
U-RAD-54	240 or 480			
U-RAD-55V	208 or 275	5000	62-7/16	53-9/16
U-RAD-55	240 or 480			
U-RAD-62V	208 or 275	3800	50	41-1/8
U-RAD-62	240			
U-RAD-63V	208 or 275	4100	53-1/8	44-1/4
U-RAD-63	240			
U-RAD-64V	208 or 275	4800	61-1/16	52-3/16
U-RAD-64	240 or 480			
U-RAD-65V	208 or 275	5500	68-1/2	59-5/8
U-RAD-65	240 or 480			
U-RAD-66V	208 or 275	6000	74-1/2	65-5/8
U-RAD-66	240 or 480			
U-RAD-72V	208 or 275	4400	56-1/8	47-1/4
U-RAD-72	240			
U-RAD-73V	208 or 275	4700	59-1/4	50-3/8
U-RAD-73	240			
U-RAD-74V	208 or 275	5400	67-1/8	58-1/4
U-RAD-74	240 or 480			
U-RAD-75V	208 or 275	6100	74-1/2	65-5/8
U-RAD-75	240 or 480			
U-RAD-76V	208 or 275	6600	80-5/8	71-3/4
U-RAD-76	240 or 480			
U-RAD-77V	208 or 275	7200	86-3/4	77-7/8
U-RAD-77	240 or 480			

INSTALLATION

⚠ WARNING

ELECTRIC SHOCK HAZARD. Disconnect all power before installing or servicing heater. Failure to do so could result in personal injury or property damage. Heater must be installed or serviced by a qualified person in accordance with the National Electrical Code, NFPA 70.

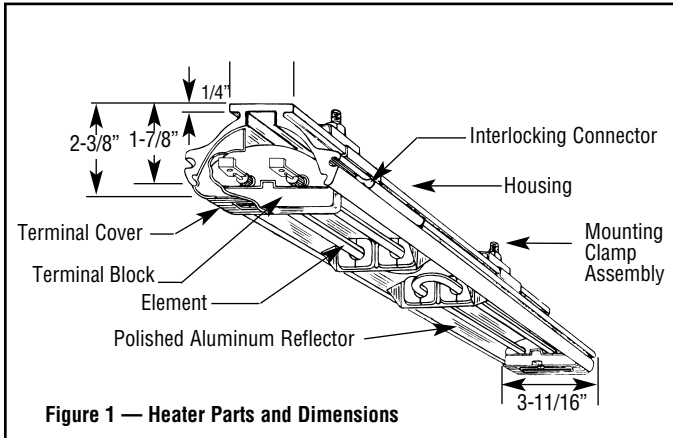

Figure 1 — Heater Parts and Dimensions

Mounting

1. These radiant heaters are designed for indoor installation only.
2. Clamps — Heaters are mounted by means of the mounting clamp and 3/8" bolt assembly which is used as shown in Fig. 2. Clamp assembly may be attached to heater by sliding over end or by snapping over top of extruded frame section at any point along its length (see Fig. 3). For proper heater support, the maximum distance between clamps must not exceed 48". On extra-long heaters, more than two clamps are furnished.

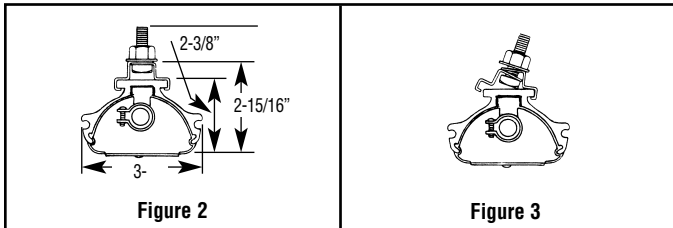

Figure 2

Figure 3

3. Mounting Holes — When heaters are mounted adjacent to each other in the same plane, note that distance between mounting holes on framing to support heaters will be 3-11/16" minimum. When heaters are not in the same plane, i.e. set at an angle to one another, distance between mounting holes in framing will be either greater or less than 3-11/16".

4. Framing — Where an extensive installation is being made, the use of continuous slot metal framing manufactured by several concerns will be of assistance in saving time and money. The frame is reusable.

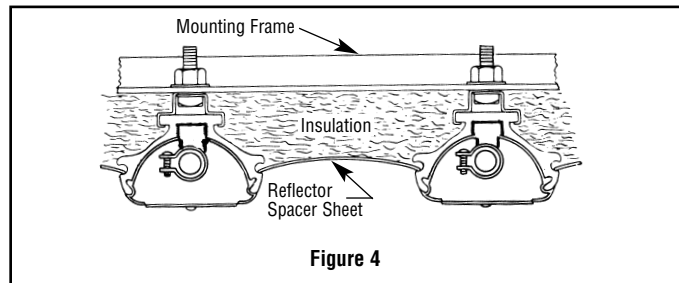

Figure 4

5. Reflector Spacer Sheets — Where heaters are not mounted side by side (see Fig. 4), reflector spacer sheets can be used between heaters. These reflector spacer sheets and companion reflectors consisting of an extruded aluminum housing with reflector sheet and mounting clamps are available. Check with local sales representative.
6. Insulation — Where unusually high work temperatures are encountered, it may be desirable to insulate backs of heaters with high-temperature fibrous insulation. A suggested method of accomplishing this is indicated in Fig. 4.
7. Ventilation — Where solvents, water, etc. are being evaporated from work in process, it is necessary to provide substantial quantities of ventilation air to carry away the resulting vapors.

⚠ WARNING

FIRE HAZARD. Since Radiant heaters are capable of developing high temperatures, extreme care should be taken to:

A. Keep combustible materials at least 6" away from sides and back of heater housing and its supporting brackets and spaced far enough in front of heater (heating element side) so thermal radiation from the elements will not ignite combustible materials.

B. If combustible materials are being processed, stoppage of process should initiate immediate heater shutdown and interception of residual heat from radiant heaters (use radiation baffles or move heaters away from work).

C. In the case of solvents of an explosive nature, ventilation air must be in sufficient volume to dilute the solvent vapor so that explosive mixtures cannot occur, refer to NFPA 86, Standard for Ovens and Furnaces.

WIRING

⚠ WARNING

ELECTRIC SHOCK HAZARD. Disconnect all power before installing or servicing heater. Failure to do so could result in personal injury or property damage. Heater must be installed or serviced by a qualified person in accordance with the National Electrical Code, NFPA 70.

⚠ WARNING

ELECTRIC SHOCK HAZARD. Any installation involving electric heaters must be performed by a qualified person and must be effectively grounded in accordance with the National Electrical Code to eliminate shock hazard.

1. Electrical connection to the type U-RAD Radiant Heater is made through the 7/8" dia. opening in the end of the terminal cover of the element assembly. A 1/2" flexible conduit connector is provided with each element assembly for this purpose.
2. Wiring should be run in flexible or rigid metal conduit and must be installed in accordance with the requirements of the National Electrical Code and such other local requirements by a qualified person as defined in the NEC.
3. Access to the element terminals is obtained by removing the mounting bolt and nut (see Figure 8, item ⑬ and ⑭) and sliding the terminal end of the element assembly out of the housing.
4. Wires supplying power to heating element terminals shall have insulation rated for 150°C minimum.

CAUTION

High temperatures will oxidize copper. Use only nickel-plated copper wire for supplying power to heater. Do not use aluminum conductors.

5. A sufficient length of this wire (not less than 12") should be used to extend from each heater terminal into a connection box location where the temperature does not exceed 300°F.
6. Assemble terminal, screw and wire as shown in Fig. 5.

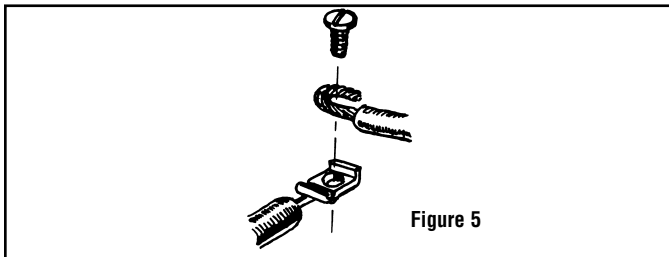

7. Hold terminal with pliers and tighten the terminal screw securely with a screwdriver.
Note: Where circuit wiring is installed in locations of high ambient temperature, conductors should be insulated in accordance with requirements for temperature and voltage.

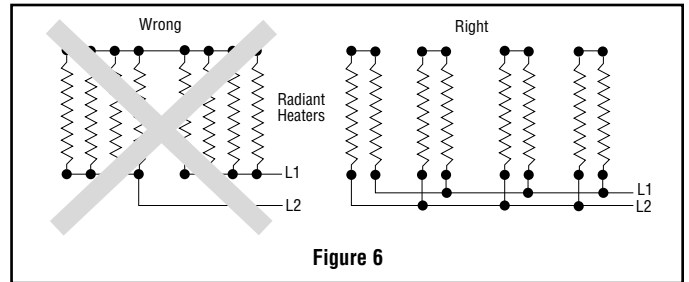

8. **SERIES CONNECTION** of Radiant Heaters of equal volt and watt rating is permitted in all line voltages up to 600 volts. In making such series connections it is necessary to observe the "right" (series-parallel) connection rather than the "wrong" (parallel-series) connection both shown in Figure 6. If heaters are connected according to the "wrong" illustration, failure of any one heater will cause progressive failure of other heaters still operating.

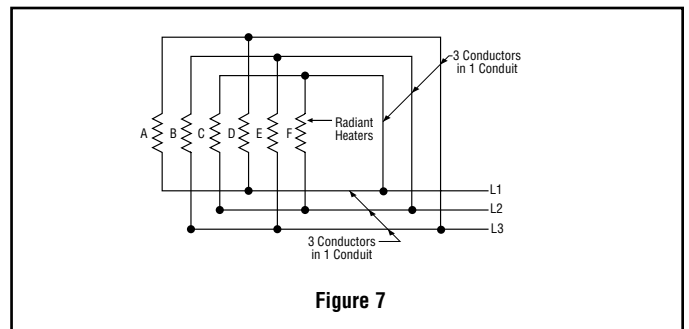

9. **DELTA CONNECTIONS** — When heaters occur in multiples of three, they may be connected to, and balanced across, three-phase lines. The most commonly used connection is the delta connection illustrated in Figure 7.

Three phase Delta connections to minimize inductive effect in conduits are made per this diagram. The rule: run all 3 three-phase conductors in the same conduit as far as possible. For single-phase, run only two conductors and follow the same rule.

OPERATION

⚠ WARNING

FIRE/EXPOSITION HAZARD. *This heater is not intended for use in hazardous atmospheres where flammable vapors, gases, liquids or other combustible atmospheres are present as defined in the National Electrical Code. Failure to comply can result in personal injury or property damage.*

Before energizing this heater:

1. **Be sure** all electrical connections are tightly made. Hold terminal with pliers when tightening screw.
2. **Be sure** that all conductors are properly insulated.
3. **Be sure** that all element assemblies have been properly replaced, and that secondary insulation bushings have not been omitted.

A. Controlling Radiant Intensity —

Standard Radiant Heaters are built to operate at approximately 40 watts per sq. inch on the element sheath. When it is desired to reduce radiant intensity, one or more of the following methods may be used.

1. **INPUT CONTROLLERS.** These motor-driven cycling devices can be used to vary heater output capacity from 4 to 100%. They are usually connected in holding coil circuit of magnetic contactors. See Chromalox Radiant Heater Manual for further information regarding Input Controllers and Contactors.

2. SOLID STATE THYRISTOR POWER CONTROLLERS.

For best non-contact control of radiant heat, a Series #6 Chromalox Thyristor Power Controller with manual potentiometer setting is recommended. Truly proportional output of from 0-100% can be easily dialed-in to suit the particular product or process requirements. The Series #6 panels are pre-engineered, pre-packaged assemblies in an enclosure with circuit disconnect provided and ready for installation.

B. Maximum Ambient Temperatures —

CHROMALOX Radiant Heaters are not recommended for applications in ambient temperature exceeding 450°F. Higher ambient temperatures mean shorter heater life.

Maximum work temperature in a given time depends on several factors: Reflectivity of work, specific heat of work, mass of work, kW input and losses from oven, and time of exposure. As work temperature increases, the work loses heat by radiation and by convection to the surrounding ambient. Although it is a general principle of Radiant Heater application that work temperature conventionally exceeds ambient temperature, in cases where extremely high work temperatures are desired, it is necessary to enclose the heaters in order to increase the ambient. If evaporation of a liquid is desired as a result of increasing work temperature, it is necessary to provide ventilation air in order to carry away the evaporated liquid. Under carefully engineered circumstances, a maximum work temperature of 600°F may be attained.

MAINTENANCE

⚠ WARNING

ELECTRIC SHOCK HAZARD. *Disconnect all power before installing or servicing heater. Failure to do so could result in personal injury or property damage. Heater must be installed or serviced by a qualified person in accordance with the National Electrical Code, NFPA 70.*

A. To Remove Heating Element —

1. Remove element assembly mounting nut and bolt (Ⓚ) and (Ⓛ) and element support clips (see Figure 8) and slide element assembly out of housing.
2. Disconnect heating element from electrical leads at both ends.
3. Remove screws from porcelain terminal blocks.
4. Remove element support clips and secondary insulating bushings.
5. Lift element out of heater.

B. To Install Element —

Observe instructions for removing element and proceed in reverse fashion. Be sure to replace secondary insulating bushings.

C. Care of Reflectors —

Reflectors should be cleaned periodically. A mild soap and water solution or fine cleaning powder is best although more drastic means may be required if reflectors are badly soiled by chemical or other deposits. The reflector is aluminum. DO NOT use alkali cleaners since alkalies will dull reflector. Mild non-alkaline cleaners, such as used for scouring kitchen sinks, may be used. Reflectors are replaceable and may be purchased from Chromalox.

RENEWAL PARTS IDENTIFICATION

Model	Volts	kW	② Element	③ Reflector	④ Aluminum Housing
U-RAD-43	208	2900	UTU-4-208V UTU-3-208V	234-016383-003 234-016383-002	152-016376-005
	240		UTU-4-240V UTU-3-240V	234-016383-003 234-016383-002	
	275		UTU-4-275V UTU-3-275V	234-016383-003 234-016383-002	
U-RAD-44	208 240 275	3600	UTU-4(2)-208V UTU-4(2)-240V UTU-4(2)-275V	234-016383-003 (2)	152-016376-006
U-RAD-52	208	3300	UTU-5-208V UTU-2-208V	234-016383-004 234-016383-001	152-016376-007
	240		UTU-5-240V UTU-2-240V	234-016383-004 234-016383-001	
	275		UTU-5-275V UTU-2-275V	234-016383-004 234-016383-001	
U-RAD-53	208	3600	UTU-5-208V UTU-3-208V	234-016383-004 234-016383-002	152-016376-008
	240		UTU-5-240V UTU-3-240V	234-016383-004 234-016383-002	
	275		UTU-5-275V UTU-3-275V	234-016383-004 234-016383-002	
U-RAD-54	208	4300	UTU-5-208V UTU-4-208V	234-016383-004 234-016383-003	152-016376-009
	240		UTU-5-240V UTU-4-240V	234-016383-004 234-016383-003	
	275		UTU-5-275V UTU-4-275V	234-016383-004 234-016383-003	
	480		UTU-5-480V UTU-4-480V	234-016383-004 234-016383-003	
U-RAD-55	208 240 275 480	5000	UTU-5(2)-208V UTU-5(2)-240V UTU-5(2)-275V UTU-5(2)-480V	234-016383-004 (2) 234-016383-004 (2) 234-016383-004 (2) 234-016383-004 (2)	152-016376-010
U-RAD-62	208	3800	UTU-6-208V UTU-2-208V	234-016383-005 234-016383-001	152-016376-011
	240		UTU-6-240V UTU-2-240V	234-016383-005 234-016383-001	
	275		UTU-6-275V UTU-2-275V	234-016383-005 234-016383-001	
U-RAD-63	208	4100	UTU-6-208V UTU-3-208V	234-016383-005 234-016383-002	152-016376-012
	240		UTU-6-240V UTU-3-240V	234-016383-005 234-016383-002	
	275		UTU-6-275V UTU-3-275V	234-016383-005 234-016383-002	
U-RAD-64	208	4800	UTU-6-208V UTU-4-208V	234-016383-005 234-016383-003	152-016376-013
	240		UTU-6-240V UTU-4-240V	234-016383-005 234-016383-003	
	275		UTU-6-275V UTU-4-275V	234-016383-005 234-016383-003	
	480		UTU-6-480V UTU-4-480V	234-016383-005 234-016383-003	

Model	Volts	kW	② Element	③ Reflector	④ Aluminum Housing
U-RAD-65	208	5500	UTU-6-208V UTU-5-208V	234-016383-005 234-016383-004	152-016376-014
	240		UTU-6-240V UTU-5-240V	234-016383-005 234-016383-004	
	275		UTU-6-275V UTU-5-275V	234-016383-005 234-016383-004	
U-RAD-66	208	6000	UTU-6(2)-208V UTU-6(2)-240V	234-016383-005 (2) 234-016383-005 (2)	152-016376-015
	275		UTU-6(2)-275V UTU-6(2)-480V	234-016383-005 (2) 234-016383-005 (2)	
	480		UTU-6-480V UTU-5-480V	234-016383-005 234-016383-004	
U-RAD-72	208	4400	UTU-7-208V UTU-2-208V	234-016383-006 234-016383-001	152-016376-016
	240		UTU-7-240V UTU-2-240V	234-016383-006 234-016383-001	
	275		UTU-7-275V UTU-2-275V	234-016383-006 234-016383-001	
U-RAD-73	208	4700	UTU-7-208V UTU-3-208V	234-016383-006 234-016383-002	152-016376-017
	240		UTU-7-240V UTU-3-240V	234-016383-006 234-016383-002	
	275		UTU-7-275V UTU-3-275V	234-016383-006 234-016383-002	
U-RAD-74	208	5400	UTU-7-208V UTU-4-208V	234-016383-006 234-016383-003	152-016376-018
	240		UTU-7-240V UTU-4-240V	234-016383-006 234-016383-003	
	275		UTU-7-275V UTU-4-275V	234-016383-006 234-016383-003	
	480		UTU-7-480V UTU-4-480V	234-016383-006 234-016383-003	
U-RAD-75	208	6100	UTU-7-208V UTU-5-208V	234-016383-006 234-016383-004	152-016376-015
	240		UTU-7-240V UTU-5-240V	234-016383-006 234-016383-004	
	275		UTU-7-275V UTU-5-275V	234-016383-006 234-016383-004	
	480		UTU-7-480V UTU-5-480V	234-016383-006 234-016383-004	
U-RAD-76	208	6600	UTU-7-208V UTU-6-208V	234-016383-006 234-016383-005	152-016376-019
	240		UTU-7-240V UTU-6-240V	234-016383-006 234-016383-005	
	275		UTU-7-275V UTU-6-275V	234-016383-006 234-016383-005	
	480		UTU-7-480V UTU-6-480V	234-016383-006 234-016383-005	
U-RAD-77	208 240 275 480	7200	UTU-7(2)-208V UTU-7(2)-240V UTU-7(2)-275V UTU-7(2)-480V	234-016383-006 (2) 234-016383-006 (2) 234-016383-006 (2) 234-016383-006 (2)	152-016376-020

STANDARD PARTS USED ON ALL HEATERS

⑤ Terminal Block	303-014316-001
⑥ Terminal Block	303-014317-001
⑦ Terminal Cover	080-016868-001
⑧ Bracket	027-016372-001
⑨ Spacer Bushing	032-075525-012
⑩ 1/2" Flexible Conduit Connector and Locknut	119-075454-005 200-075482-002
⑪ Terminal Screw	248-046044-002
⑫ Element Support Clip	059-014304-002

⑬ Insulating Bushing	032-013454-001
⑭ Bushing Retaining Clip	059-017175-001
⑮ Mounting Clamp Parts Bag — For mounting heaters with overall length less than 74-1/2", use Parts Bag 168-013071-001. For heaters with 74-1/2" or larger overall length, use Parts Bag 168-013071-002.		

MISCELLANEOUS HARDWARE

⑯ #8-32 Nut	200-075520-064
⑰ #8-32 x 1-3/4" Screws	248-075512-194
⑱ #8-32 x 1" Screws	248-075512-185
⑲ #8 Washer	328-075528-036

Note: Part Numbers suffixed by a number in () indicates the number of parts of the same part number used or supplied if more than one.

RENEWAL PARTS IDENTIFICATION

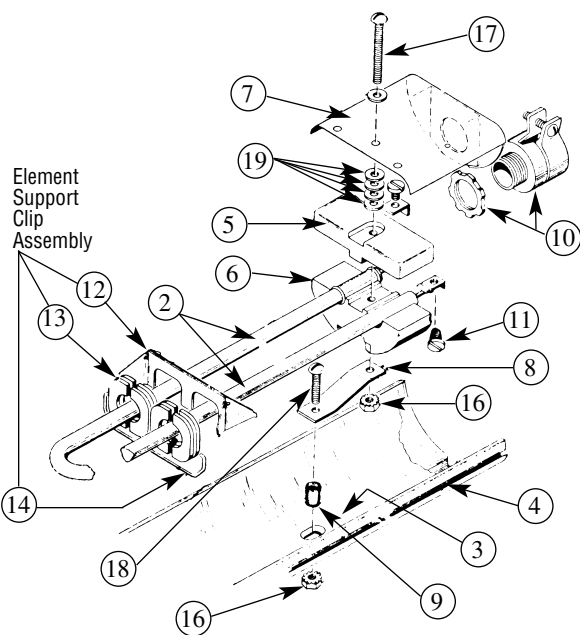

① Element assembly includes all parts shown except item ③ and ④
 For element assembly part number, add prefix "R" to Element part number ② Ex: **R** UTU-6-208V.

Model	Volts	kW	② Element	③ Reflector	④ Aluminum Housing
U-RAD-2	120 208 240 275	800	UTU-2-120V UTU-2-208V UTU-2-240V UTU-2-275V	234-016383-001	152-016384-001

Model	Volts	kW	② Element	③ Reflector	④ Aluminum Housing
U-RAD-3	120 208 240 275	1100	UTU-3-120V UTU-3-208V UTU-3-240V UTU-3-275V	234-016383-002	152-016384-002
U-RAD-4	208 240 275 480	1800	UTU-4-208V UTU-4-240V UTU-4-275V UTU-4-480V	234-016383-003	152-016384-003
U-RAD-5	208 240 275 480	2500	UTU-5-208V UTU-5-240V UTU-5-275V UTU-5-480V	234-016383-004	152-016384-004
U-RAD-6	208 240 275 480	3000	UTU-6-208V UTU-6-240V UTU-6-275V UTU-6-480V	234-016383-005	152-016384-005
U-RAD-7	208 240 275 480	3600	UTU-7-208V UTU-7-240V UTU-7-275V UTU-7-480V	234-016383-006	152-016384-006
U-RAD-22	120 208 240 275	1600	UTU-2(2)-120V UTU-2(2)-208V UTU-2(2)-240V UTU-2(2)-275V	234-016383-001 (2)	152-016376-001
U-RAD-32	120	1900	UTU-3-120V UTU-2-120V	234-016383-002 234-016383-001	152-016376-002
	208		UTU-3-208V UTU-2-208V	234-016383-002 234-016383-001	
	240		UTU-3-240V UTU-2-240V	234-016383-002 234-016383-001	
	275		UTU-3-275V UTU-2-275V	234-016383-002 234-016383-001	
U-RAD-33	120 208 240 275	2200	UTU-3(2)-120V UTU-3(2)-208V UTU-3(2)-240V UTU-3(2)-275V	234-016383-002 (2)	152-016376-003
U-RAD-42	208	2600	UTU-4-208V UTU-2-208V	234-016383-003 234-016383-001	152-016376-004
	240		UTU-4-240V UTU-2-240V	234-016383-003 234-016383-001	
	275		UTU-4-275V	234-016383-003	
	275		UTU-2-275V	234-016383-001	

Limited Warranty:

Please refer to the Chromalox limited warranty applicable to this product at <http://www.chromalox.com/customer-service/policies/termsforsale.aspx>.



2150 N. RULON WHITE BLVD., OGDEN, UT 84404

Free Manuals Download Website

<http://myh66.com>

<http://usermanuals.us>

<http://www.somanuals.com>

<http://www.4manuals.cc>

<http://www.manual-lib.com>

<http://www.404manual.com>

<http://www.luxmanual.com>

<http://aubethermostatmanual.com>

Golf course search by state

<http://golfingnear.com>

Email search by domain

<http://emailbydomain.com>

Auto manuals search

<http://auto.somanuals.com>

TV manuals search

<http://tv.somanuals.com>