

Chromalox®

Installation, Operation and **RENEWAL PARTS IDENTIFICATION**

SERVICE REFERENCE

DIVISION 4	SECTION RAD
SALES REFERENCE (Supersedes PG407-2)	PG407-3
161-048766-001	
DATE	FEBRUARY, 1987

Chromalox Type RAD Radiant Heaters **Converting Styles 0, 1, 3 and 3A to 3B**

GENERAL

The current Chromalox Style 3B RAD has superseded earlier Styles 0, 1, 3 and 3A RAD heaters. These instructions are for converting these earlier models to the current Style 3B. This conversion is necessary because replacement parts for the old models are no longer available.

The changes involved are primarily in the terminal area as shown in Figures I, 2 and 3. Match-up one of the Figures with your

heater's terminal arrangement and order the corresponding parts bag (Figures 4 and 5). If an element or other part listed in Table A (page 3) is necessary, order according to heater housing length and the voltage and wattage stamped on the element and the heater name-plate.

For complete installation information for type RAD - Style 3B, request Chromalox Service Reference sheet PG404.

CONVERSION

CAUTION: Hazard of electric shock. Disconnect power before servicing heater.

A. CONVERTING STYLES 0 AND 1 TO STYLE 3B RADIANT HEATER

1. Completely disassemble heater. Re-use the heating element (if desired) and the extruded aluminum housing (Fig. 7). Scrap all the other parts.
2. Drill #24 (.152" dia.) hole in the back of the extruded housing **A**, 3" from each end. (See Fig. 7)
3. **NOTE:** If replacing old element with a new one, omit this step. Remove wire retaining loops **B** (Fig. 6) from the elements and replace with wire loops fashioned from #15 gage (.072" dia.) or larger stainless steel wire located 2-1/4" from each end of the sheath. Other high temperature materials such as nichrome may be substituted. Braze or tack weld the loops in position.
4. Besides the Parts Bag 168-016585-002 (Fig. 4), you will need insulation bushings **6**, element support clips **7**, reflector **2** and element (if required) as listed in Table A, page 2.

NOTE: Quantities of these parts, as well as size of element and reflector will be determined by the heater housing length of the old unit.

5. Assemble heater as shown in Figure 7.

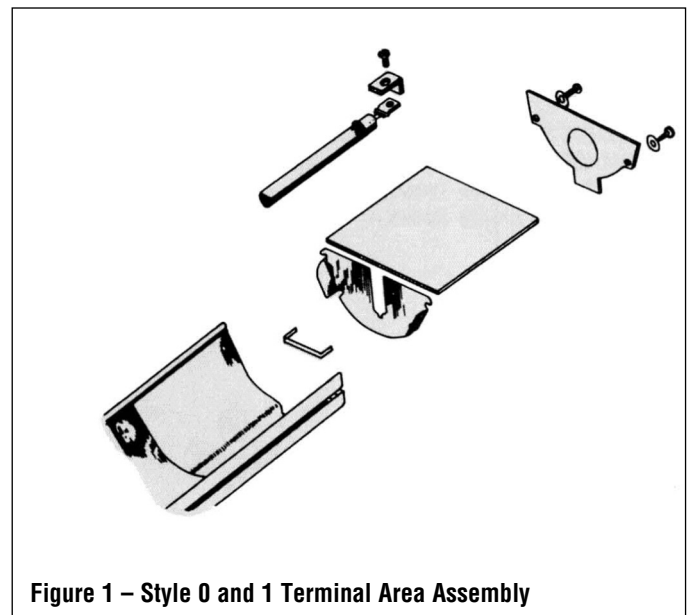
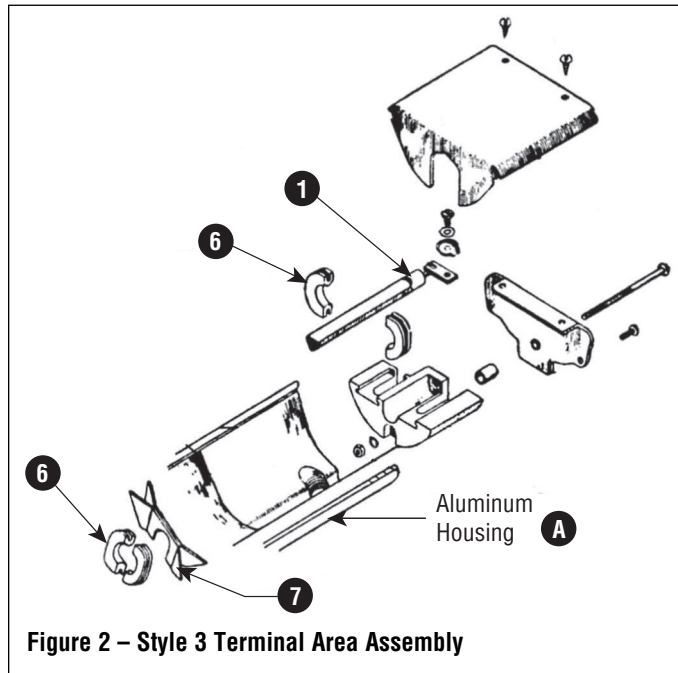

Figure 1 - Style 0 and 1 Terminal Area Assembly

CONVERSION (cont'd.)

B. CONVERTING STYLE 3 TO STYLE 3B RADIANT HEATER



C. CONVERTING STYLE 3A TO STYLE 3B RADIANT HEATER

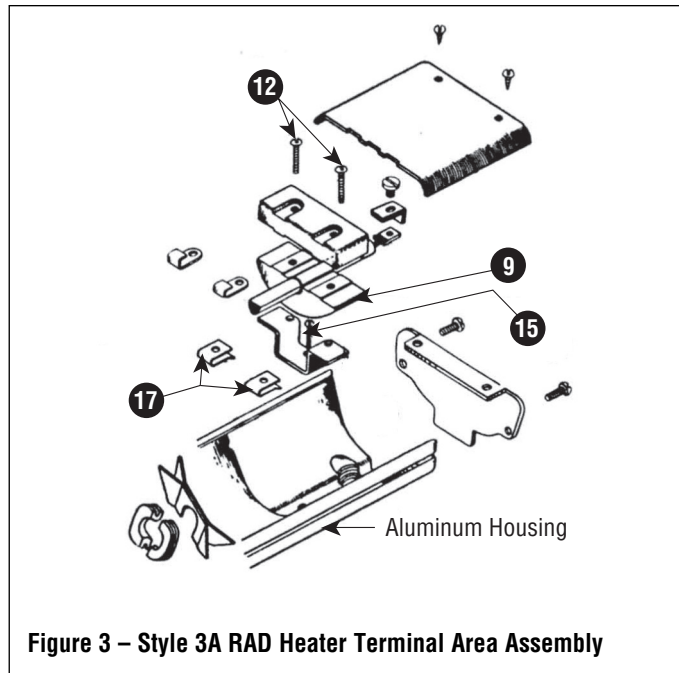

1. Completely disassemble heater. Re-use the heating element **1** (if desired), the extruded aluminum housing, the element support clips **7** and insulation bushing **6**. Scrap all other parts.
 2. Drill #24 (.152" dia.) hole in the wiring trough of the extruded housing **A**, 3" from each end.
- NOTE:** If replacing old element with a new one, omit steps 3 and 4.
3. Remove terminal connector from terminal pin and replace with terminal connector 302-019961-002. The location of this connector is as shown in Figure 6.
 4. Fashion wire loops from #15 gage (.072" dia.) or larger high temperature wire (such as stainless steel or nichrome) and braze or tack weld these loops in position 2-1/4" from each sheath end of the element.
 5. Assemble heater as shown in Figure 7 using Parts Bag 168-016585-002.

1. Completely disassemble heater. Scrap the bottom terminal blocks **9**, the terminal block support brackets **16**, the Tinnerman® "U" speed nuts **17**, the terminal block support bracket screws **15** and the terminal block screws **12**. Re-use all the other parts, including the heating element unless a new one is required. In this case order an element from Table A, page 3 with same voltage and wattage and for same heater housing length as old unit.
2. Assemble heater as shown in Figure 7 using Parts Bag 168-016585-001.

RENEWAL PARTS IDENTIFICATION

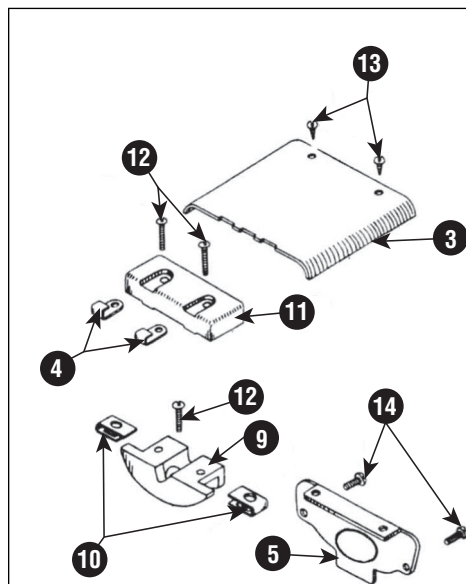

Figure 4 - Parts Bag 168-016505-002 (to convert Style 0, 1 and 3B)

PARTS BAG 168-016585-001 Consists of:

- 3** Terminal Cover.....306-014405-001 (2)
- 4** Terminal Cover Clip.....056-014401-002 (4)
- 5** End Plate.....220-017278-001 (2)
- 9** Terminal Block.....303-016367-001 (2)
- 10** Speed Nuts.....272-048153-005 (4)
- 11** Terminal Block.....303-014326-001 (2)
- 12** Screws - #8 x 1".....248-075519-095 (6)
- 13** Screws - #8 x 3/8".....248-075519-080 (4)
- 14** Screws - #8-32 x 3/8".....248-075512-053 (4)

PARTS BAG 168-016585-001 Consists of:

- 9** Terminal Block.....303-016367-001 (2)
- 10** Speed Nuts.....272-048153-005 (4)
- 11** Terminal Block.....303-014326-001 (2)
- 12** Screws - #8 x 1" Lg.248-075519-095 (6)

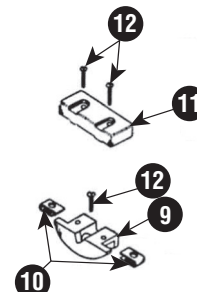

Figure 5 - Parts Bag 168-016585-001 (to convert Style 3A to Style 3B)

RENEWAL PARTS IDENTIFICATION

MISCELLANEOUS HARDWARE

Screws

- ⑧ Terminal Screw248-046044-002(2)
- ⑫ #8 x 1" Lg.....248-075519-095(6)
- ⑬ #8 x 3/8" Lg.....248-075519-080(4)
- ⑭ #8-32 x 3/8" Lg.....248-075512-053(4)

MISCELLANEOUS HARDWARE

- ⑧ Terminal Screw303-016367-001(2)
- ⑩ Speed Nuts272-048153-005(4)
- ⑪ Terminal Block.....303-014326-001(2)
- ⑮ Saddle Clamp238-026539-001(2)

HEATER MOUNTING CLAMP ASSEMBLY

For mounting heater with catalog numbers up to Cat. No. RAD 7000 use mounting clamp assembly part no. 168-013071-001. For mounting heaters above Cat. No. RAD 7000 use mounting clamp assembly part no. 168-013071-002.

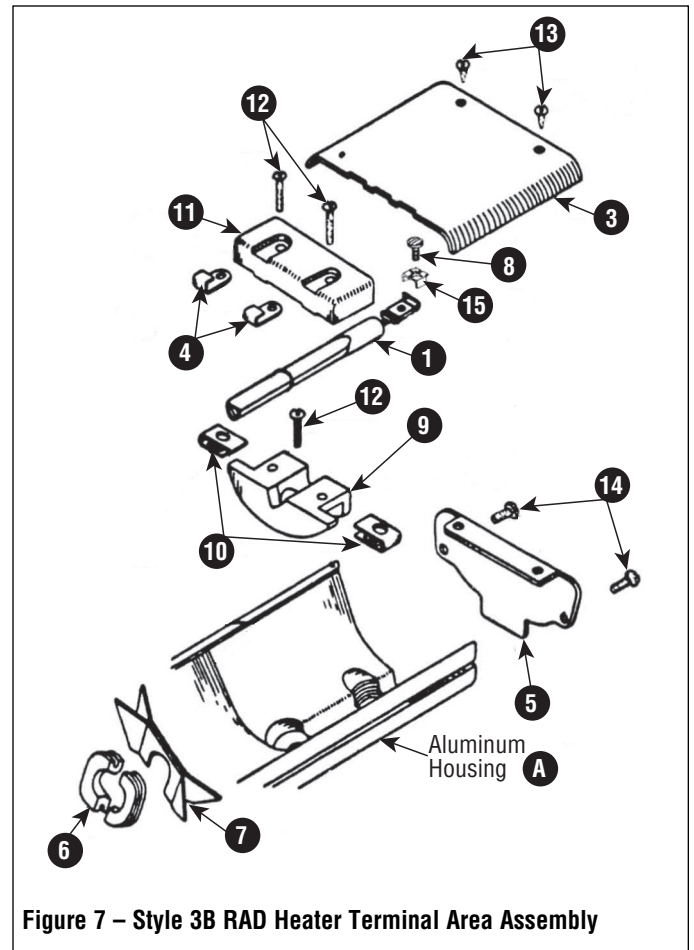

Figure 7 – Style 3B RAD Heater Terminal Area Assembly

Heater Housing Length	Volts	Watts	① Element Catalog Number	② Reflector Sheet	⑥ Insulation Bushing	⑦ Element Support Clip
24-3/8"	120 208 240 275	800	RTU-2083A-120V RTU-2083AV RTU-2083A-240V RTU-2083AV-275V	234-013411-001	_____	_____
30-5/8"	120 208 240 275	1100	RTU-3113A-120V RTU-3113AV RTU-3113A-240V RTU-3113AV	234-013411-012	_____	_____
46-5/8"	208 240 275 480	1800	RTU-4183AV RTU-4183A-240V RTU-4183AV RTU-4183A-480	234-013411-014	032-013454-001 (2)	059-013424-001
61-3/8"	208 240 275 480	2500	RTU-5253AV RTU-5253A-240V RTU-5253AV RTU-5253A-480V	234-013411-016	032-013454-001 (6)	059-013424-001 (3)
73-3/4"	208 240 275 480	3000	RTU-6303AV RTU-6303A-240V RTU-6303AV RTU-6303A-480V	234-013411-018	032-013454-001 (8)	059-013424-001 (4)
85-3/4"	208 240 275 480	3600	RTU-7363AV RTU-7363A-240 RTU-7363AV RTU-7363A-480V	234-013411-004* and 234-013411-012*	032-013454-001 (10)	059-013424-001 (5)

*For ease of installation, these reflectors shipped in two pieces (one each of part numbers listed).

NOTE: Part numbers suffixed by a number in () Indicates the quantity of the same part number used.

Limited Warranty:
Please refer to the Chromalox limited warranty applicable to this product at
<http://www.chromalox.com/customer-service/policies/termsofsale.aspx>.

Chromalox[®]
PRECISION HEAT AND CONTROL

2150 N. RULON WHITE BLVD., OGDEN, UT 84404

Phone: 1-800-368-2493 www.chromalox.com

Download from www.S0manuals.com. All Manuals Search And Download.

Free Manuals Download Website

<http://myh66.com>

<http://usermanuals.us>

<http://www.somanuals.com>

<http://www.4manuals.cc>

<http://www.manual-lib.com>

<http://www.404manual.com>

<http://www.luxmanual.com>

<http://aubethermostatmanual.com>

Golf course search by state

<http://golfingnear.com>

Email search by domain

<http://emailbydomain.com>

Auto manuals search

<http://auto.somanuals.com>

TV manuals search

<http://tv.somanuals.com>