

# Chromalox®

## Installation, Operation

and

## RENEWAL PARTS IDENTIFICATION

Please familiarize yourself with these instructions before attempting to install or connect this radiant heater

### SERVICE REFERENCE

DIVISION 4	SECTION	U-RP
SALES REFERENCE (Supersedes PG424-1)		PG424-2
161-058090-001		
DATE	JULY, 2006	

## Type U-RP Radiant Heater

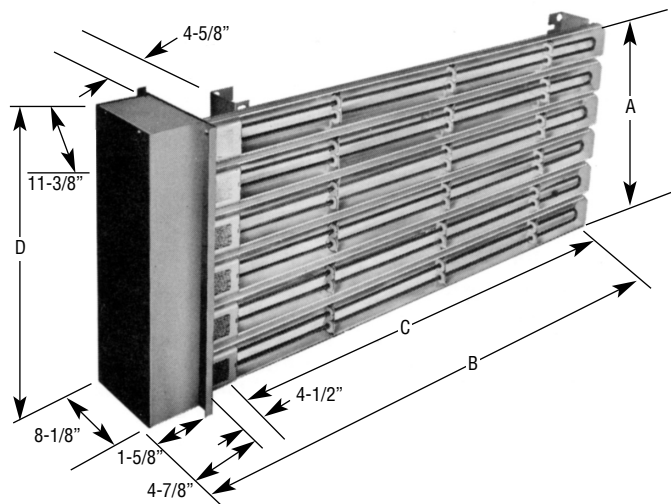

Specifications – Table A

Model	Volts	kW	Dimensions (In.)			
			A	B Overall Length	C Heated Length	D Overall Height
U-RP-410V U-RP-410	208 or 275 240 or 480	13.2 13.2	11-5/8 11-5/8	57-1/2 57-1/2	48 48	12 12
U-RP-420V U-RP-420	208 or 275 240 or 480	26.4 26.4	23-5/8 23-5/8	57-1/2 57-1/2	48 48	24 24
U-RP-510V U-RP-510	208 or 275 240 or 480	18 18	11-5/8 11-5/8	75-1/2 75-1/2	66 66	12 12
U-RP-520V U-RP-520	208 or 275 240 or 480	36 36	23-5/8 23-5/8	75-1/2 75-1/2	66 66	24 24

### Before installing

1. Open carton and remove heater at the place of installation.
2. Check nameplate volt and watt rating against your power supply voltage and heating requirements of your installation. This nameplate is located on one end of the heater.

## MOUNTING

1. **Framing:** Fabricate structural support using angle iron or continuous slot metal framing (manufactured by others). Dimension framing per Table B and Figure 1 for your size panel.

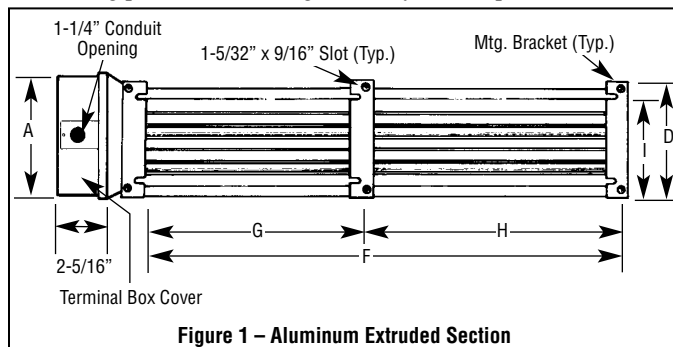

Figure 1 – Aluminum Extruded Section

Mounting – Table A

Model	No. of Mounting Brackets	Dimensions (In.)			
		F	G	H	I
U-RP-410V U-RP-410	2	44-3/4	—	—	8-5/8
U-RP-420V U-RP-420	2	44-3/4	—	—	20-5/8
U-RP-510V U-RP-510	3	62-3/4	32-1/4	30-1/2	8-5/8
U-RP-520V U-RP-520	3	62-3/4	32-1/4	30-1/2	20-5/8

2. **Assembly:** Position U-RP radiant panel on fabricated structural support and attach using 1/2" diameter bolts of suitable length (see Fig. 2).

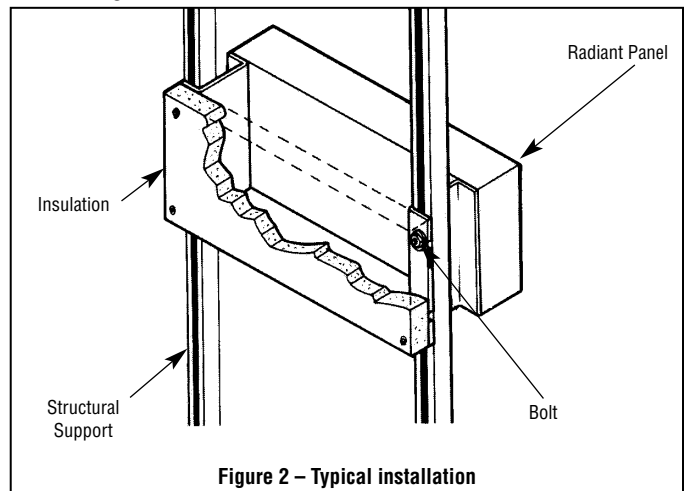

Figure 2 – Typical installation

3. **Insulation:** Where unusually high work temperatures are encountered, it may be desirable to insulate backs of heaters with high temperature fibrous insulation. A suggested method of accomplishing this is indicated in Figure 2.

## MOUNTING (cont'd.)

4. **Ventilation:** Where solvents, water etc. are being evaporated from work in process, it is necessary to provide substantial quantities of ventilation air to carry away the resulting vapors.

### ⚠ WARNING

**FIRE HAZARD:** Since Radiant heaters are capable of developing high temperatures, extreme care should be taken to:

- A. Keep combustible materials at least 6" away from sides and back of heater housing and its supporting brackets and spaced far enough in front of heater (heating element side) so thermal radiation from the elements will not ignite combustible materials.**

**B. If combustible materials are being processed, stoppage of process should initiate immediate heater shutdown and interception of residual heat from radiant heaters (use radiation baffles or move heaters away from work).**

- C. In the case of solvents of an explosive nature, ventilation air must be in sufficient volume to dilute the solvent vapor so that explosive mixtures cannot occur, refer to NFPA 86, Standard for Ovens and Furnaces.**

## WIRING

### ⚠ WARNING

**ELECTRIC SHOCK HAZARD. Disconnect all power before installing or servicing heater. Failure to do so could result in personal injury or property damage. Heater must be installed or serviced by a qualified person in accordance with the National Electrical Code, NFPA 70.**

### ⚠ WARNING

**ELECTRIC SHOCK HAZARD. Any installation involving electric heaters must be performed by a qualified person and must be effectively grounded in accordance with the National Electrical Code to eliminate shock hazard.**

1. Electrical connections to the Radiant Panel are made through the 1-1/4" dia. opening in the terminal housing.
2. Wiring should be run in flexible or rigid metal conduit and must be installed in accordance with the requirements of the National Electric Code and such other local requirements as may be applicable.
3. Access to the busbars is obtained by removing the screws in the terminal box cover.  
**NOTE:** Where circuit wiring is installed in locations of high ambient temperature, conductors should be insulated in accordance with requirements for temperature and voltage.
4. A 9/32" dia. hole is provided at each end of the busbar for the purpose of connecting the circuit wiring to the type U-RP radiant panel. Use 1/4-20 bolts, nuts and lockwashers for making connections. It is suggested that crimp-on connectors with a hole for 1/4" bolt be attached to the ends of circuit wires to facilitate making these connections.

## OPERATION

### ⚠ WARNING

**FIRE/EXPOSION HAZARD. This heater is not intended for use in hazardous atmospheres where flammable vapors, gases, liquids or other combustible atmospheres are present as defined in the National Electrical Code. Failure to comply can result in personal injury or property damage.**

### ⚠ WARNING

**The system designer is responsible for the safety of this equipment and should install adequate back-up controls and safety devices with their electric heating equipment. Where the consequences of failure could result in personal injury or property damage, back-up controls are essential.**

**CAUTION: For your own safety –**

Before energizing this heater:

1. Be sure all electrical connections are tightly made.
2. Be sure that all conductors are properly insulated.
3. Be sure that the terminal cover has been properly replaced.

**A. Controlling Radiant Intensity –**

Standard Radiant Panels are built to operate at 40 watts per square inch on the element sheath. When it is desired to reduce the radiant intensity, one or more of the following methods may be used.

1. **INPUT CONTROLLERS** These motor-driven cycling devices can be used to vary heater output capacity from 4 to 100%. They

are usually connected in holding coil circuit of magnetic contactors. See Chromalox Radiant Heater Manual for further information regarding Input Controllers and Contactors.

2. **SOLID STATE THYRISTOR POWER CONTROLLERS** For best non-contact control of radiant heat, a Series #6 Chromalox Thyristor Power Controller with manual potentiometer setting is recommended. Truly proportional output from 0-100% can be easily dialed-in to suit the particular product or process requirements. The Series #6 panels are pre-engineered, pre-packaged assemblies in an enclosure with circuit disconnect provided and ready for installation.

**B. Maximum Ambient Temperatures –**

CHROMALOX Radiant Panels are not recommended for applications in ambient temperatures exceeding 450°F. Higher ambient temperatures mean shorter heater life.

Maximum work temperature in a given time depends on several factors: Reflectivity of work, specific heat of work, mass of work, kW input and losses from oven and time of exposure. As work temperature increases, the work loses heat by radiation and by convection to the surrounding ambient. Although it is a general principle of Radiant Heater application that work temperature conventionally exceeds ambient temperature, in cases where extremely high work temperatures are desired, it is necessary to enclose the heaters in order to increase the ambient temperature. If evaporation of a liquid is desired as a result of increasing work temperature, it is necessary to provide ventilation air in order to carry away the evaporated liquid. Under carefully engineered circumstances, a maximum work temperature of 600°F may be attained.

## MAINTENANCE

### ⚠ WARNING

**ELECTRIC SHOCK HAZARD. Disconnect all power before installing or servicing heater. Failure to do so could result in personal injury or property damage. Heater must be installed or serviced by a qualified person in accordance with the National Electrical Code, NFPA 70.**

#### To Remove Heating Element

1. Remove terminal cover screws (13) and terminal cover (3) at terminal end of heater.
2. Disconnect heating element from electrical leads at both ends.
3. Remove screws (12) and nuts (10) from porcelain terminal blocks (9) and (11).
4. Remove element support clips (7) and (15) and secondary insulation bushings.
5. Lift element out of heater.

#### To Install Element

Observe instructions for removing element and proceed in reverse order. Be sure to replace secondary insulation bushings.

#### Care of Reflectors

Reflectors should be cleaned periodically. A mild soap and water solution or fine cleaning powder is best although more drastic means may be required if reflectors are badly soiled by chemical or other deposits. The reflector is aluminum. DO NOT use alkali cleaners since alkalis will dull reflector. Mild non-alkaline cleaners, such as used for scouring kitchen sinks, may be used. Reflectors are replaceable and may be purchased from Chromalox.

## RENEWAL PARTS IDENTIFICATION

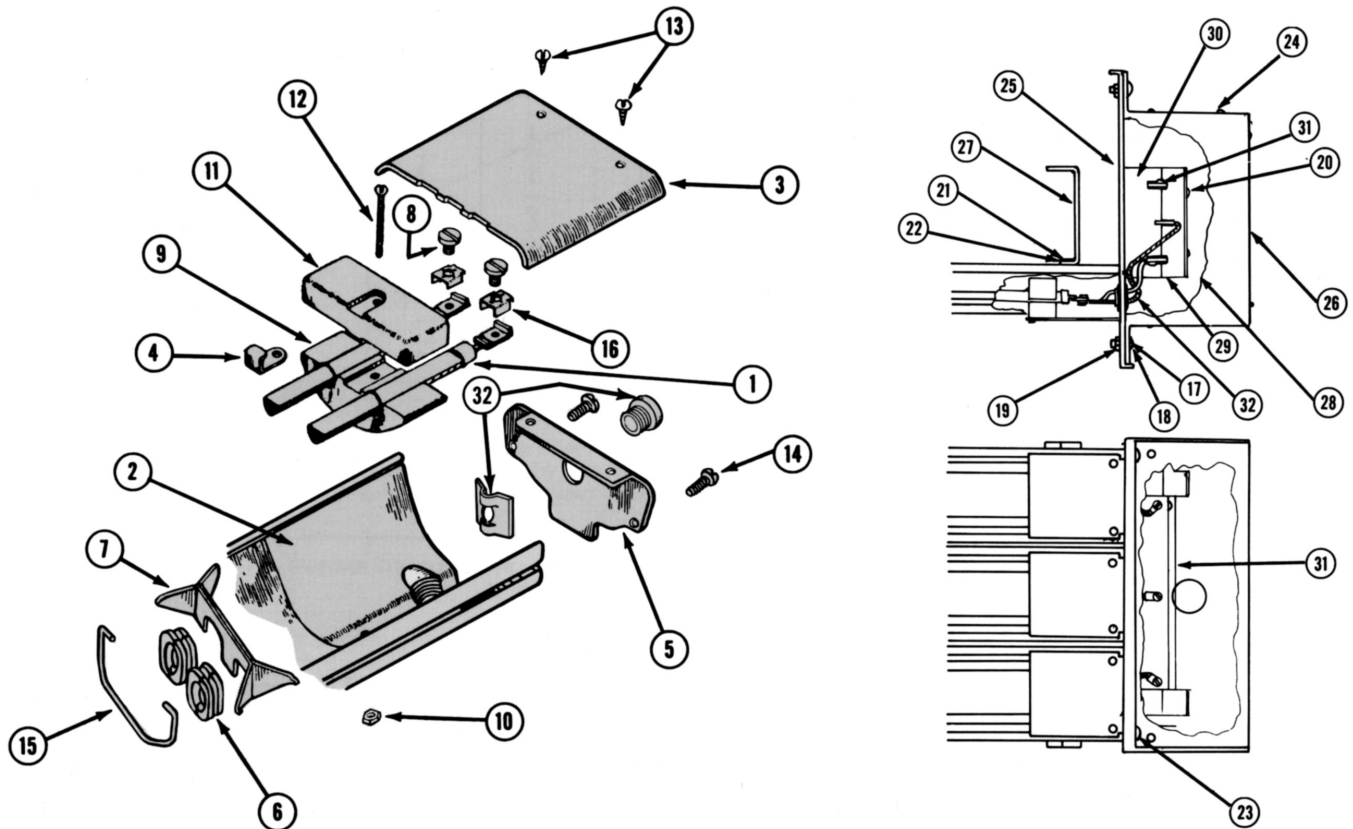

Model	Volts	Number of Elements	kW Per Element	① Element Model No.	② Reflector Sheet	⑥ Insulation Bushing	⑦ Element Support Clip	⑮ Bushing Retaining Clip
U-RP-410	208 or 275 240 or 480	3	4.4	URPT-444V URPT-444	234-013411-082 (3)	032-013454-001 (48)	059-014304-002 (12)	059-017175-001 (12)
U-RP-420	208 or 275 240 or 480	6		URPT-444V URPT-444	234-013411-082 (6)	032-013454-001 (96)	059-014304-002 (24)	059-017175-001 (24)
U-RP-510	208 or 275 240 or 480	3	6.0	URPT-560V URPT-560	234-013411-083 (3)	032-013454-001 (60)	059-014304-002 (15)	059-017175-001 (15)
U-RP-520	208 or 275 240 or 480	6		URPT-560V URPT-560	234-013411-083 (6)	032-013454-001 (120)	059-014304-002 (30)	059-017175-001 (30)

**NOTE:** Part numbers suffixed by a number in ( ) indicates the quantity of the same part number used

## RENEWAL PARTS IDENTIFICATION (cont'd.)

Description	Part Number	Quantity Used Per Heater			
		U-RP-410	U-RP-510	U-RP-420	U-RP-520
<b>PARTS COMMON TO ALL HEATERS</b>					
③ Terminal Cover	306-014405-001	3	3	6	6
④ Terminal Cover Clip	056-014401-002	3	3	6	6
⑤ End Plates (Terminal End)	220-016382-001	3	3	6	6
	220-017278-001	3	3	6	6
⑧ Terminal Screw	248-046044-002	6	6	12	12
<b>MISCELLANEOUS HARDWARE AND PARTS</b>					
⑨ Terminal Block	303-014317-001	3	3	6	6
⑩ Hexnut #8-32	200-049592-029	3	3	6	6
⑪ Terminal Block	303-014316-001	3	3	6	6
⑫ Screw #8-32 x 2-1/2" Long	248-075512-390	3	3	6	6
⑬ Screw #8 x 3/8" Long	248-075519-080	6	6	12	12
⑭ Screw #8-32 x 3/8" Long	248-075512-053	12	12	24	24
⑮ Saddle Clamp	238-026539-001	6	6	12	12
⑯ Screw 1/4-20 x 3/8" Long	248-075512-260	4	4	4	4
⑰ Washer 1/4"	328-075528-053	4	4	4	4
⑱ Hexnut 1/4-20	200-075520-070	4	4	4	4
⑳ Screw 10-32 x 2-3/4" Long	248-075512-419	4	4	4	4
㉑ Cap Screw 3/8-16 x 1/2" Long	345-115337-222	6	9	9	18
㉒ Lockwasher	328-024417-023	6	9	9	18
㉓ Screw 1/4 x 1-1/4" Long	248-075409-314	6	9	12	12
㉔ Screw 10-32 x 3/8" Long	248-075512-089	1	1	1	1
	015-051109-001	1	1	—	—
㉕ Base Plates	015-043319-001	—	—	1	1
	306-014374-001	1	1	—	—
㉖ Terminal Box Covers	306-014374-002	—	—	1	1
	050-051107-001	2	3	—	—
㉗ Connecting Channels	050-051107-002	—	—	2	3
	306-014448-001	2	2	2	2
㉘ Terminal Box End Plate	306-014448-001	2	2	2	2
㉙ Bus Bar Support	219-0143800001	2	2	2	2
㉚ Bus Bar Support	219-014381-001	2	2	2	2
㉛ Bus Bar	031-051116-001	2 (1ø) 3 (3ø)	2 (1ø) 3 (3ø)	—	—
	031-051116-002	—	—	2 (1ø)	2 (1ø)
	—	—	—	3 (3ø)	3 (3ø)
㉜ Bushing (with Locknut)	032-075008-003	3	3	6	6

**Limited Warranty:**

Please refer to the Chromalox limited warranty applicable to this product at  
<http://www.chromalox.com/customer-service/policies/termsforsale.aspx>.

**Chromalox®**  
**PRECISION HEAT AND CONTROL**

2150 N. RULON WHITE BLVD., OGDEN, UT 84404  
 Phone: 1-800-368-2493      www.chromalox.com

## Free Manuals Download Website

<http://myh66.com>

<http://usermanuals.us>

<http://www.somanuals.com>

<http://www.4manuals.cc>

<http://www.manual-lib.com>

<http://www.404manual.com>

<http://www.luxmanual.com>

<http://aubethermostatmanual.com>

Golf course search by state

<http://golfingnear.com>

Email search by domain

<http://emailbydomain.com>

Auto manuals search

<http://auto.somanuals.com>

TV manuals search

<http://tv.somanuals.com>