

# Chromalox®

## Installation and OPERATION INSTRUCTIONS

**Note:** Please familiarize yourself with these instructions before attempting to install or connect this Radiant Heater.

### Type S-RAD Electric Radiant Heater



#### Before Installing

1. Open carton and remove heater at the place of installation. Mounting clamps are in parts bag in carton.
2. Check nameplate volt and watt rating against your power supply voltage and heating requirements of your installation. This nameplate is located on one end of the heater.

#### MOUNTING

#### ⚠ WARNING

**ELECTRIC SHOCK HAZARD. Disconnect all power before installing or servicing heater. Failure to do so could result in personal injury or property damage. Heater must be installed by a qualified person in accordance with the National Electrical Code, NFPA 70.**

1. **Clamps** — Heaters are mounted by means of the mounting clamp and  $\frac{3}{8}$ " bolt assembly which is used as shown in Figure 2. Clamp assembly may be attached to heater by sliding over end or by snapping over top of extruded frame section at any point along its length (see Figure 3). For proper heater support, the maximum distance between clamps must not exceed 48". On extra-long heaters, more than two clamps are furnished.
2. **Mounting Holes** — When heaters are mounted adjacent to each other in the same plane, note that distance between mounting holes on framing to support heaters will be  $3\frac{1}{16}$ " minimum. When heaters are not in the same plane, i.e., set at an angle to one another, distance between mounting holes in framing will be either greater or less than  $3\frac{1}{16}$ ".
3. **Framing** — Where an extensive installation is being made, the use of continuous slot metal framing manufactured by several concerns will be of assistance in saving time and money. The framing is reusable.
4. **Reflector Spacer Sheets** — Where heaters are not mounted side by side (see Figure 4), reflector spacer sheets can be used between heaters. These reflector spacer sheets and companion reflectors consisting of an extruded aluminum housing with reflector sheet and mounting clamps are available. Check factory.
5. **Insulation** — Where unusually high work temperatures are encountered, it may be desirable to insulate backs of heaters with high-temperature fibrous insulation. A suggested method of accomplishing this is indicated in Figure 4.
6. **Ventilation** — Where solvents, water, etc. are being evaporated from work in process, it is necessary to provide substantial quantities of ventilation air to carry away the resulting vapors.

#### SERVICE REFERENCE

DIVISION 4	SECTION RAD
SALES REFERENCE (Supersedes PG422-1)	PG422-2
161-058066-001	
DATE	SEPTEMBER, 2001

#### Specifications

Model	Volts	kW	Length (In.)	
			Overall	Heated
S-RAD-2 S-RAD-2V	120 or 240 208 or 275	0.95	24-3/8	16-1/2
S-RAD-3 S-RAD-3V	120 or 240 208 or 275	1.3	30-5/8	22-3/4
S-RAD-4V S-RAD-4	208 or 275 240 or 480	2.2	46-5/8	38-5/8
S-RAD-5V S-RAD-5	208 or 275 240 or 480	3.0	61-3/8	53-3/8
S-RAD-6V S-RAD-6	208 or 275 240 or 480	3.75	73-3/4	65-3/4
S-RAD-7V S-RAD-7	208 or 275 240 or 480	4.4	85-3/4	77-3/4

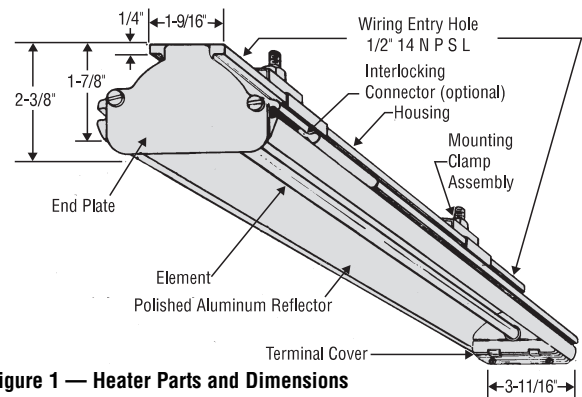

Figure 1 — Heater Parts and Dimensions

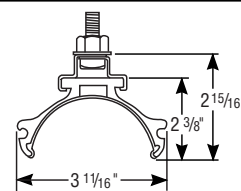

Figure 2

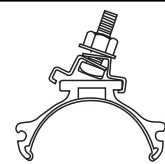

Figure 3

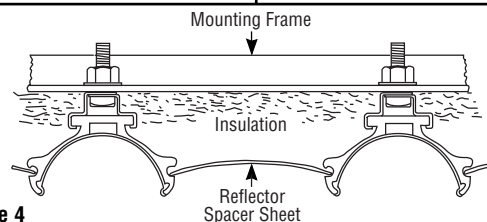

Figure 4

#### ⚠ WARNING

**Hazard of Fire. In the case of solvents of an explosive nature, ventilation air must be in sufficient volume to dilute the solvent vapor so that explosive mixtures cannot occur. In order to comply with the standards of safety required by the insurance companies, ventilation protection and other facilities must be in accordance with National Fire Protection Association Bulletin No. 86, entitled "Standard for Class A Ovens and Furnaces". This bulletin may be obtained from the Association at 1 Batterymarch Park, Quincy, MA 02269.**

## WIRING

### ⚠ WARNING

**ELECTRIC SHOCK HAZARD.** Any installation involving electric heaters must be performed by a qualified person and must be effectively grounded in accordance with the National Electrical Code to eliminate shock hazard.

1. Electrical connection to the Radiant Heater is made through one opening tapped for 1/2" connector. Opening is in the top of the extruded heater housing, near the terminal end.
2. Wiring should be run in flexible or rigid metal conduit and must be installed in accordance with local codes and the National Electrical Code by a qualified person.

**CAUTION: High temperatures will oxidize copper. Do not use copper wire in connecting this heater. Insulated, nickel-plated copper wire is recommended.**

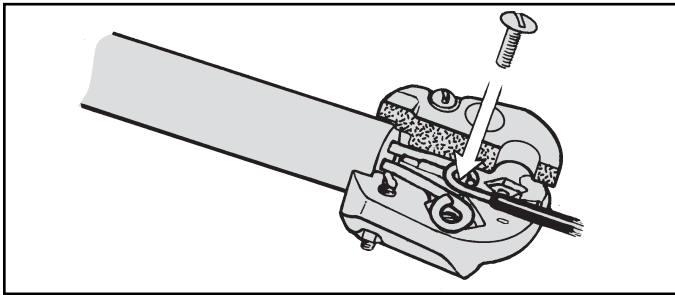

Figure 5 — Tightening Terminal Screws

3. Access to Radiant Heater terminals is obtained by removing the two screws in the terminal cover.
  4. A sufficient length of this wire (not less than 12") should be used to extend from each heater terminal into a connection box location where the temperature does not exceed 300°F.
  5. Assemble terminal, screw and wire as shown in Figure 5.
  6. Tighten the terminal screws securely with a screwdriver.
- Note:** Where circuit wiring is installed in locations of high ambient temperature, conductors should be insulated in accordance with requirements for temperature and voltage.

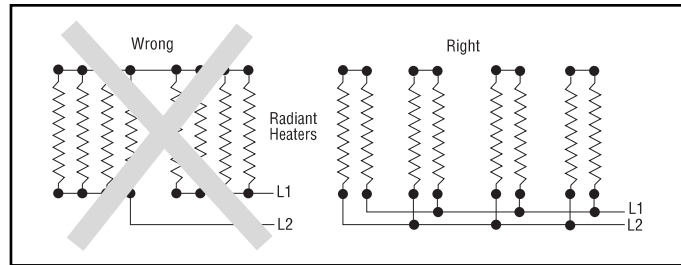

Figure 6 — Series Connection

7. **SERIES CONNECTION** of Radiant Heaters of equal volt and watt rating is permitted in all line voltages up to 600 volts. In making such series connections it is necessary to observe the "right" (series-parallel) connection rather than the "wrong" (parallel-series) connection both shown in Figure 6. If heaters are connected according to the "wrong" illustration, failure of any heater will cause progressive failure of other heaters still operating.
8. **DELTA CONNECTIONS** — When heaters occur in multiples of three, they may be connected to, and balanced across, three-phase lines. The most commonly used connection is the Delta connection illustrated in Figure 7.

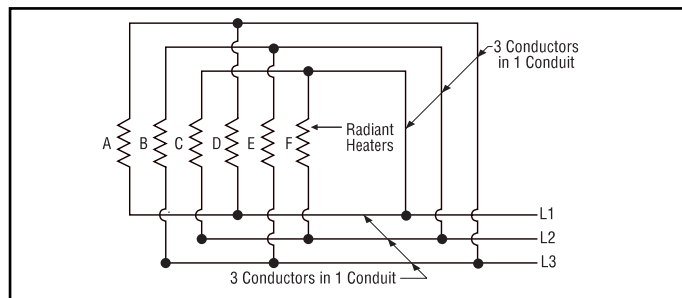

Figure 7 — Delta Connection

Three phase Delta connections to minimize inductive effect in conduits are made per this diagram. **The rule:** run all 3 three-phase conductors in the same conduit as far as possible. For single-phase, run only two conductors and follow the same rule.

## OPERATION

### ⚠ WARNING

**Hazard of Fire.** In the case of solvents of an explosive nature, ventilation air must be in sufficient volume to dilute the solvent vapor so that explosive mixtures cannot occur. In order to comply with the standards of safety required by the insurance companies, ventilation protection and other facilities must be in accordance with National Fire Protection Association Bulletin No. 86, entitled "Standard for Class A Ovens and Furnaces". This bulletin may be obtained from the Association at 1 Batterymarch Park, Quincy, MA 02269.

Before energizing this heater:

1. Be sure all electrical connections are tightly made.
2. Be sure that all conductors are properly insulated, and that they will not chafe at the heater wire entrance due to expansion and contraction of the heating element.
3. Be sure that all terminal covers have been properly replaced, and that secondary insulation bushings have not been omitted.

#### A. Controlling Radiant Intensity —

Standard Radiant Heaters are built to operate at 40 watts per sq. inch on the element sheath. When it is desired to reduce radiant intensity, one or more of the following methods may be used.

1. **INPUT CONTROLLERS** — These motor-driven cycling devices can be used to vary heater output capacity from 4 to 100%. They are usually connected in holding coil circuit of magnetic contactors. See Chromalox Radiant Heater

Manual for further information regarding Input Controllers and Contactors.

2. **SOLID STATE THYRISTOR POWER CONTROLLERS** — For best non-contact control of radiant heat, a Series #6 Chromalox Thyristor Power Controller with manual potentiometer setting is recommended. Truly proportional output of from 0-100% can be easily dialed-in to suit the particular product or process requirements. The Series #6 panels are pre-engineered, pre-packaged assemblies in an enclosure with circuit disconnect provided and ready for installation.

#### B. Maximum Ambient Temperatures —

Chromalox Radiant Heaters are not recommended for applications in ambient temperatures exceeding 450°F. Higher ambient temperatures mean shorter heater life.

Maximum work temperature in a given time depends on several factors: Reflectivity of work, specific heat of work, mass of work, kW, input and losses from oven, and time of exposure. As work temperature increases, the work loses heat by radiation and by convection to the surrounding ambient. Although it is a general principle of Radiant Heater application, the work temperature conventionally exceeds ambient temperature, in cases where extremely high work temperatures are desired, it is necessary to enclose the heaters in order to increase the ambient. If evaporation of a liquid is desired as a result of increasing work temperature, it is necessary to provide ventilation air in order to carry away the evaporated liquid. Under carefully engineered circumstances, a maximum work temperature of 600°F may be attained.

## MAINTENANCE

### ⚠ WARNING

**ELECTRIC SHOCK HAZARD. Disconnect all power to heater before installing or servicing heater. Failure to do so could result in personal injury or property damage. Heater must be installed by a qualified person in accordance with the National Electric Code, NFPA 70.**

#### A. To Remove Heating Element —

1. Remove terminal cover screws and terminal cover.
2. Disconnect heating element from electrical leads.
3. Remove element support clips and secondary insulating bushings.

4. Lift element out of heater.

#### B. To Install Element —

Observe instructions for removing element and proceed in reverse fashion. Be sure to replace secondary insulating bushings.

#### C. Care of Reflectors —

Reflectors should be cleaned periodically. A mild soap and water solution or fine cleaning powder is best, although more drastic means may be required if reflectors are badly soiled by chemical or other deposits. The reflector is aluminum. DO NOT use alkali cleaners since alkalis will dull reflector. Mild non-alkaline cleaners, such as used for scouring kitchen sinks, may be used. Reflectors are replaceable and may be purchased from Chromalox.

## RENEWAL PARTS IDENTIFICATION

To Order: Specify quantity, part number, volts and watts.

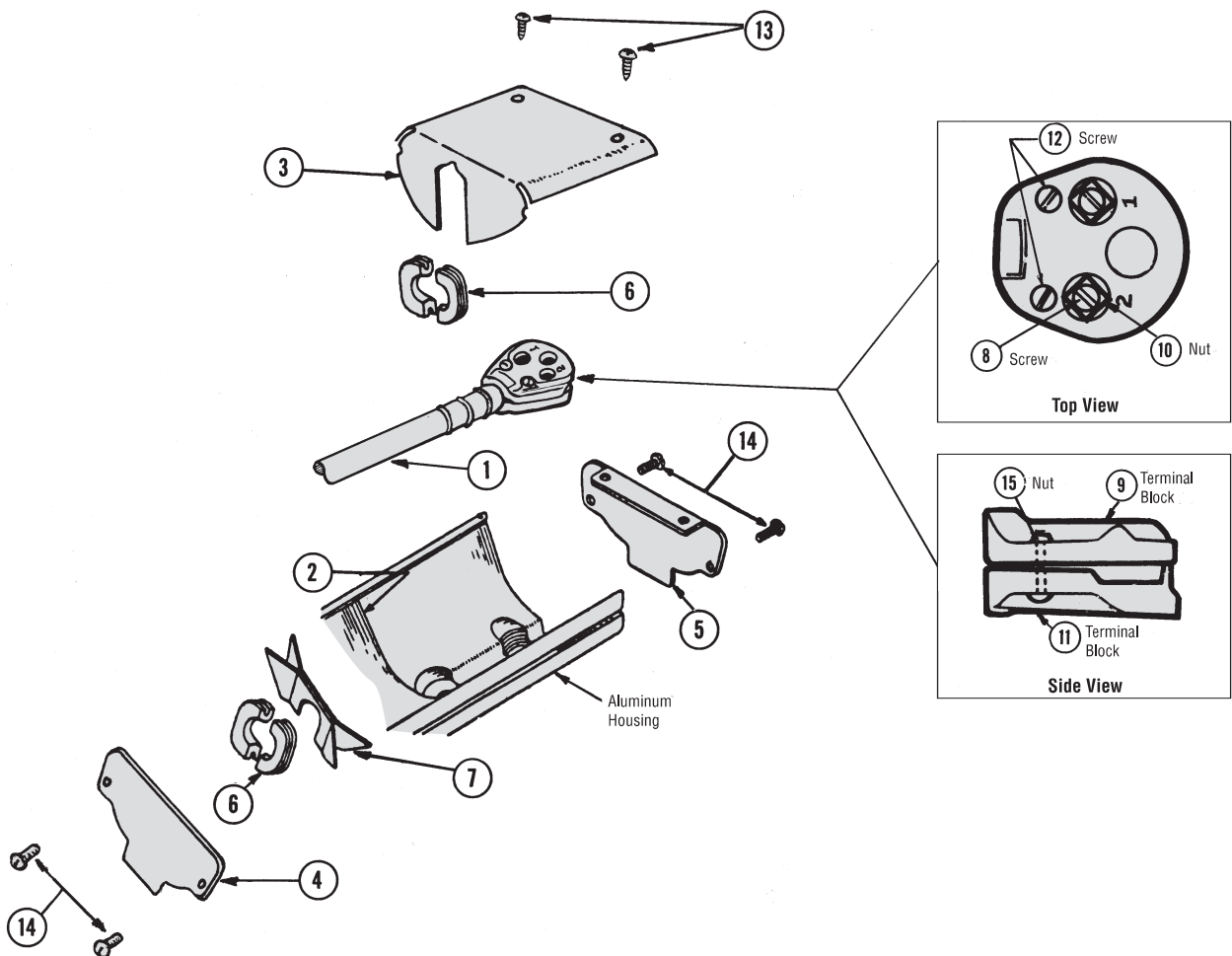

MISCELLANEOUS HARDWARE	
Description	Part Number
<b>Screws</b>	
⑧ #8-32 x 5/16" lg.	248-048161-084 (2)
⑫ #6-32 x 7/8" lg.	248-048889-245 (2)
⑬ #8 x 1/4" lg.	248-075483-173 (2)
⑭ #8-32 x 1/4" lg.	248-075409-044 (4)
<b>Nuts</b>	
⑩ #8-32	200-050619-001 (2)
⑮ #6-32	200-050621-001 (2)

PARTS COMMON TO ALL HEATERS	
Description	Part Number
③ Terminal Cover	080-013311-001
④ End Plate	220-016382-001
⑤ End Plate	220-014662-002
⑨ Terminal Block	303-050641-001
⑪ Terminal Block	303-050640-001

## RENEWAL PARTS IDENTIFICATION

Model	Volts	Watts	① Element Model No.	① Element P.N.	② Reflector Sheet	⑥ Insulation Bushing	⑦ Element Support Clip
S-RAD-2	120 208 240 275	950	SRTU-209-120 SRTU-209V-208 SRTU-209-240 SRTU-209V-275	228-024788-001 228-024788-002 228-024788-003 228-024788-004	234-013411-025	032-013454-001 (4)	059-013424-001
S-RAD-3	120 208 240 275	1300	SRTU-313-120 SRTU-313V-208 SRTU-313-240 SRTU-313V-275	228-024788-005 228-024788-006 228-024788-007 228-024788-008	234-013411-086	032-013454-001 (4)	059-013424-001
S-RAD-4	208 240 275 480	2200	SRTU-422V-208 SRTU-422-240 SRTU-422V-275 SRTU-422-480	228-024788-009 228-024788-010 228-024788-011 228-024788-012	234-013411-051	032-013454-001 (6)	059-013424-001 (2)
S-RAD-5	208 240 275 480	3000	SRTU-530V-208 SRTU-530-240 SRTU-530V-275 SRTU-530-480	228-024788-013 228-024788-014 228-024788-015 228-024788-016	234-013411-087	032-013454-001 (6)	059-013424-001 (2)
S-RAD-6	208 240 275 480	3750	SRTU-638V-208 SRTU-638-240 SRTU-638V-275 SRTU-638-480	228-024788-017 228-024788-018 228-024788-019 228-024788-020	234-013411-088	032-013454-001 (8)	059-013424-001 (3)
S-RAD-7	208 240 275 480	4400	SRTU-744V-208 SRTU-744-240 SRTU-744V-275 SRTU-744-480	228-024788-021 228-024788-022 228-024788-023 228-024788-024	234-013411-089	032-013454-001 (10)	059-013424-001 (4)

**Limited Warranty:**

Please refer to the Chromalox limited warranty applicable to this product at  
<http://www.chromalox.com/customer-service/policies/termsforsale.aspx>.

**Chromalox<sup>®</sup>**  
**PRECISION HEAT AND CONTROL**

2150 N. RULON WHITE BLVD., OGDEN, UT 84404  
 Phone: 1-800-368-2493      [www.chromalox.com](http://www.chromalox.com)

## Free Manuals Download Website

<http://myh66.com>

<http://usermanuals.us>

<http://www.somanuals.com>

<http://www.4manuals.cc>

<http://www.manual-lib.com>

<http://www.404manual.com>

<http://www.luxmanual.com>

<http://aubethermostatmanual.com>

Golf course search by state

<http://golfingnear.com>

Email search by domain

<http://emailbydomain.com>

Auto manuals search

<http://auto.somanuals.com>

TV manuals search

<http://tv.somanuals.com>