

# Chromalox®

## Installation Instructions

### SERVICE REFERENCE

DIVISION 4	SECTION GNIT
SALES REFERENCE (Supersedes PK479-2)	PK479-3
161-506172-001	
DATE	AUGUST, 2006



## GNIT Moisture and Corrosion Resistant Industrial Thermostat

### Features:

- Rugged Design
- Moisture and Corrosion Resistant
- Teflon® Covered Capillary/Bulb
- Large Setpoint Dial
- Easy Installation
- Line Voltage
- DPST 25 Amp Switch

Teflon® is a registered trademark of DuPont Co.

### Specifications —

Model	PCN	Temperature Range (°F)	Volts	Max Amps.	Capillary Length (Ft.)	Stock
GNIT-5	360946	30 to 220	120/240	25	5	S
GNIT-12	360954	30 to 220	120/240	25	12	S

Other temperature ranges available. Contact your local Chromalox Sales office.

## GENERAL

### ⚠ WARNING

**FIRE/EXPLOSION HAZARD. This thermostat is not intended for use in hazardous atmospheres where flammable vapors, gases, liquids or other combustible atmospheres are present as defined in the National Electrical Code. Failure to comply can result in personal injury or property damage.**

NOTICE: Type GNIT Thermostats are designed for temperature control service only. Because they are not fail safe, they should not be used for temperature limiting duty.

### ⚠ WARNING

**The system designer is responsible for the safety of this equipment and should install adequate back-up controls and safety devices with their electric heating equipment. Where the consequences of failure could result in personal injury or property damage, back-up controls are essential.**

The GNIT Non-Indicating Corrosive Resistant Thermostat is designed for applications in atmospheres where corrosive material is present. The double pole/single throw thermostat is available with either a 5 foot or 12 foot copper capillary which is sleeved with

Teflon®. The Teflon® also covers the bulb. The thermostat is designed for 25 amperes resistive loads for either 120 or 240 Vac.

### Specifications:

Range	30 to 220°F
Switch Action	DPST (Double Pole/Single Throw)
Current	25 Amperes, 120 or 240 Vac
Accuracy	±9°F
Load Lamp	120 Vac or 240 Vac
Capillary Length	GNIT-5, 5 Foot GNIT-12, 12 Foot
Diameter of Teflon® Cover	5/16" OD

### Application Notes

1. Customer external fuse required.

**Process Temperature Differential** — is variation in controlled process temperature between maximum, when thermostat turns OFF and minimum, when thermostat turns ON. This spread in temperature may be minimized by:

1. Making sure control is mounted to vertical surface. (See Step 1, MOUNTING.)
2. Avoid excess heating capacity (oversized heaters).
3. Locating control sensing bulb in optimum position between heat source and work.

## MOUNTING

**Note:** Do not mount thermostat where it will be subject to vibration or shock. Do not mount adjacent to a large magnetic contactor, as vibration and shock will cause thermostat to interact erratically — resulting in chattering of the contactor.

The air temperature in and around the thermostat enclosure should be kept as near to normal room temperature as possible...

never above 150°F or below 30°F.

1. Thermostat must be mounted in a vertical position only.
2. Use sheet metal or wood screws through the four 1/4" diameter mounting holes in baseplate to mount control.

## MOUNTING

### 3. NOTICE:

- A. Do not bend or deform sensing bulb. This will alter control calibration.
- B. Do not kink capillary tube. The resulting constrictions in fluid flow can destroy control function or broaden temperature differential. Minimum capillary tube bending diameter is 1/2" I.D.
- C. Any deformations of bulb or capillary that result in leakage of fluid from control renders control inoperative.
- D. Avoid passing control capillary tube through zones which have temperatures in excess of controlled process temperature. Erratic control or destruction of control function may result.

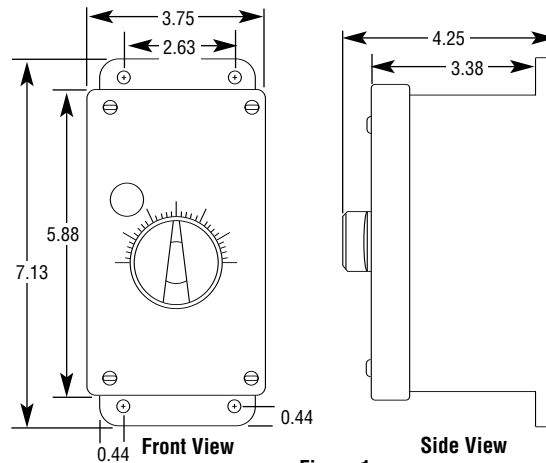

Figure 1

## WIRING

### ⚠ WARNING

**ELECTRIC SHOCK HAZARD. Disconnect all power before installing or servicing thermostat. Failure to do so could result in personal injury or property damage. Thermostat must be installed by a qualified person in accordance with the National Electrical Code, NFPA 70.**

### ⚠ WARNING

**ELECTRIC SHOCK HAZARD. Any installation involving thermostats must be performed by a qualified person and must be effectively grounded**

**in accordance with the National Electrical Code to eliminate shock hazard.**

1. Electric wiring to thermostat must be installed in accordance with the National Electrical Code and with local codes by a qualified person. **CAUTION: Use copper conductors only.**
2. Entrance for wiring is provided by two 1/2" conduit holes on each side of the unit.
3. Remove four face mounting screws and pull off front cover.
4. Connect wires according to wiring diagrams (Figures 2 & 3).
5. Replace cover and tighten screws.
6. **Note:** If load amperage or voltage rating exceeds switch rating, a contactor must be used. Contactor and wiring to be supplied by customer.

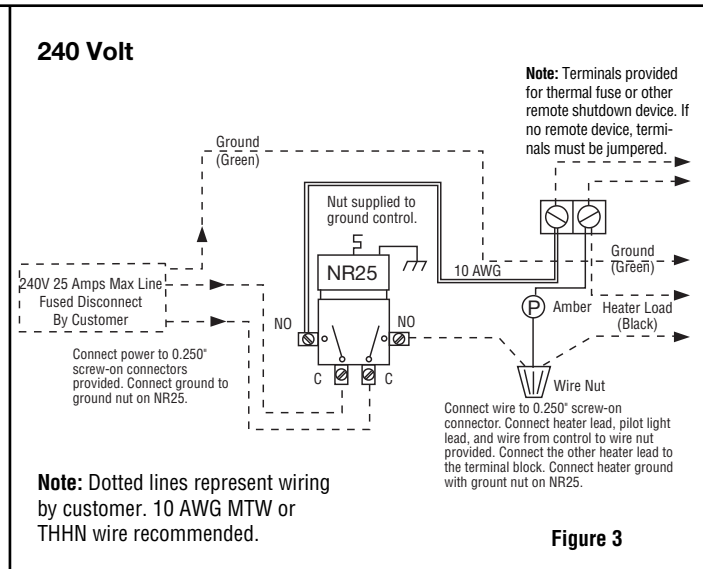
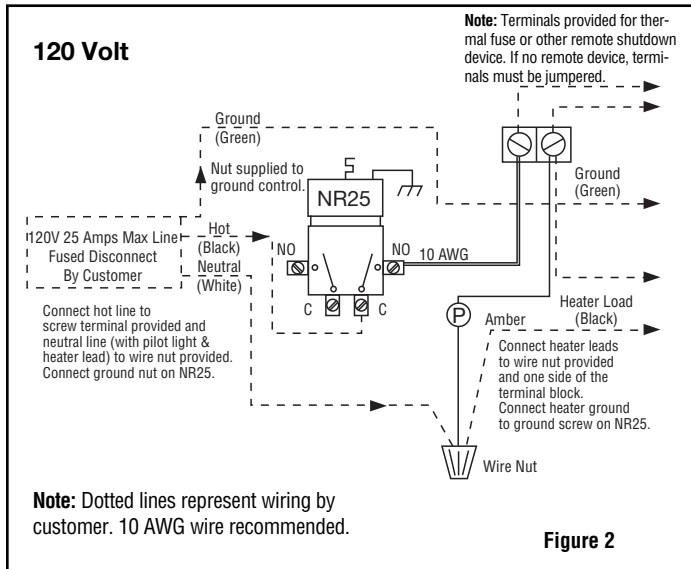

### Limited Warranty:

Please refer to the Chromalox limited warranty applicable to this product at <http://www.chromalox.com/customer-service/policies/termsofsale.aspx>.

**Chromalox**  
PRECISION HEAT AND CONTROL

1347 HEIL QUAKER BLVD., LAVERGNE, TN 37086  
Phone: (615) 793-3900 www.chromalox.com

## Free Manuals Download Website

<http://myh66.com>

<http://usermanuals.us>

<http://www.somanuals.com>

<http://www.4manuals.cc>

<http://www.manual-lib.com>

<http://www.404manual.com>

<http://www.luxmanual.com>

<http://aubethermostatmanual.com>

Golf course search by state

<http://golfingnear.com>

Email search by domain

<http://emailbydomain.com>

Auto manuals search

<http://auto.somanuals.com>

TV manuals search

<http://tv.somanuals.com>