

# BLACK & DECKER®

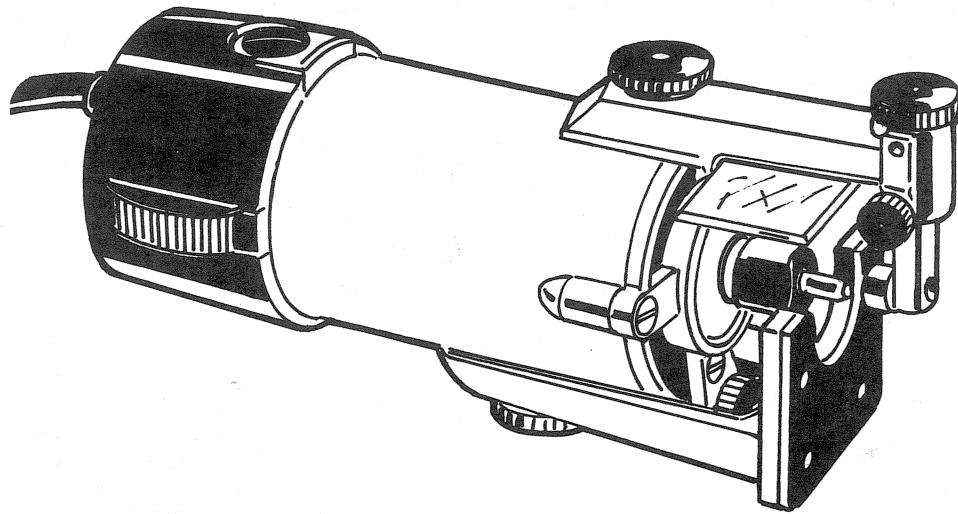

## No. 3265 LAMINATE TRIMMER

This booklet is provided for your convenience in the use and care of your new Black & Decker tool. These instructions include operation, safety precautions, preventive maintenance, maintenance and other pertinent data to assist you in assuring long life and dependable service.

## INSTRUCTION MANUAL

## IMPORTANT SAFETY INSTRUCTIONS

**WARNING:** When using electric tools, basic safety precautions should always be followed to reduce risk of fire, electric shock, and personal injury, including the following:

### READ ALL INSTRUCTIONS

### GROUNDING INSTRUCTIONS

This tool should be grounded while in use to protect the operator from electric shock. The tool is equipped with a 3-conductor cord and 3-prong grounding type plug to fit the proper grounding type receptacle. The green (or green and yellow) conductor in the cord is the grounding wire. Never connect the green (or green and yellow) wire to a live terminal. If your unit is intended for use on less than 150 V, it has a plug that looks like that shown in sketch A. If it is for use on 150 to 250 V, it has a plug that looks like that shown in sketch D. An adapter, sketches B and C, is available for connecting sketch A type plugs to 2-prong receptacles. The green-colored rigid ear, lug, or the like, extending from the adapter must be connected to a permanent ground, such as a properly grounded outlet box. No adapter is available for a plug as shown in sketch D. ADAPTER SHOWN IN FIGURES B and C IS NOT FOR USE IN CANADA. Use only 3-wire extension cords that have 3-prong grounding-type plugs and 3-pole receptacles that accept the tool's plug. Replace or repair damaged cords.

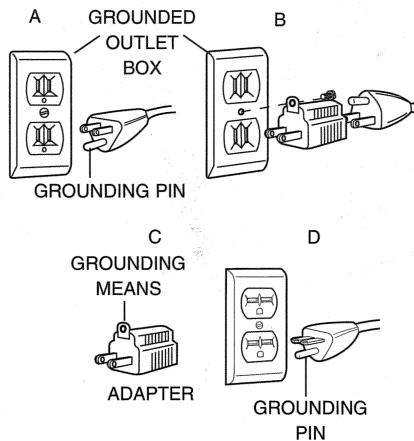

### SAFETY INSTRUCTIONS FOR ALL TOOLS

- **KEEP WORK AREA CLEAN.** Cluttered areas and benches invite injuries.
- **CONSIDER WORK AREA ENVIRONMENT.** Don't expose power tools to rain. Don't use power tools in damp or wet locations. Keep work area well lit. Do not use tool in presence of flammable liquids or gases.
- **GUARD AGAINST ELECTRIC SHOCK.** Prevent body contact with grounded surfaces. For example; pipes, radiators, ranges, and refrigerator enclosures.
- **KEEP CHILDREN AWAY.** Do not let visitors contact tool or extension cord. All visitors should be kept away from work area.
- **STORE IDLE TOOLS.** When not in use, tools should be stored in dry, and high or locked-up place — out of reach of children.
- **DON'T FORCE TOOL.** It will do the job better and safer at the rate for which it was intended.
- **USE RIGHT TOOL.** Don't force small tool or attachment to do the job of a heavy-duty tool. Don't use tool for purpose not intended.
- **DRESS PROPERLY.** Do not wear loose clothing or jewelry. They can be caught in moving parts. Rubber gloves and non-skid footwear are recommended when working outdoors. Wear protective hair covering to contain long hair.
- **USE SAFETY GLASSES.** Also use face or dust mask if operation is dusty.
- **DON'T ABUSE CORD.** Never carry tool by cord or yank it to disconnect from receptacle. Keep cord from heat, oil, and sharp edges.

- **SECURE WORK.** Use clamps or a vise to hold work. It's safer than using your hand and it frees both hands to operate tool.
- **DON'T OVERREACH.** Keep proper footing and balance at all times.
- **MAINTAIN TOOLS WITH CARE.** Keep tools sharp and clean for better and safer performance. Follow instructions for lubricating and changing accessories. Inspect tool cords periodically and if damaged, have repaired by authorized service facility. Inspect extension cords periodically and replace if damaged. Keep handles dry, clean, and free from oil and grease.
- **DISCONNECT OR LOCK OFF TOOLS** when not in use, before servicing, and when changing accessories, such as blades, bits, cutters.
- **REMOVE ADJUSTING KEYS AND WRENCHES.** Form habit of checking to see that keys and adjusting wrenches are removed from tool before turning it on.
- **AVOID UNINTENTIONAL STARTING.** Don't carry tool with finger on switch. Be sure switch is off when plugging in.
- **EXTENSION CORDS.** Make sure your extension cord is in good condition. When using an extension cord, be sure to use one heavy enough to carry the current your product will draw. An undersized cord will cause a drop in line voltage resulting in loss of power and overheating. The following table shows the correct size to use depending on cord length and nameplate ampere rating. If in doubt, use the next heavier gage. The smaller the gage number, the heavier the cord.

#### Minimum Gage for Cord Sets

Volts	Total Length of Cord in Feet			
	0-25	26-50	51-100	101-150
120V				
240V	0-50	51-100	101-200	201-300
Ampere Rating		AWG		
More Than	Not more Than			
0 -	6	18	16	16
6 -	10	18	16	14
10 -	12	16	16	14
12 -	16	14	12	Not Recommended

- **OUTDOOR USE EXTENSION CORDS.** When tool is used outdoors, use only extension cords intended for use outdoors and so marked.
- **STAY ALERT.** Watch what you are doing. Use common sense. Do not operate tool when you are tired.
- **CHECK DAMAGED PARTS.** Before further use of the tool, a guard or other part that is damaged should be carefully checked to determine that it will operate properly and perform its intended function. Check for alignment of moving parts, binding of moving parts, breakage of parts, mounting, and any other conditions that may affect its operation. A guard or other part that is damaged should be properly repaired or replaced by an authorized service center unless otherwise indicated elsewhere in this instruction manual. Have defective switches replaced by authorized service center. Do not use tool if switch does not turn it on and off.

### SAVE THESE INSTRUCTIONS

## LUBRICATION

The Laminate Trimmer and Router are completely lubricated at the factory—all ball bearings are of the closed type and lubricant lasts the life of the bearing.

## END CAPS

The black end cap is made from a special high impact, polycarbonate material which can be damaged by various solvents, adhesives, gasoline, and some detergents.

**CAUTION:** The end cap should be cleaned by wiping with a dry rag or by blowing off with compressed air. If a solvent must be used, kerosene is recommended.

## ATTACHING BITS & CUTTERS

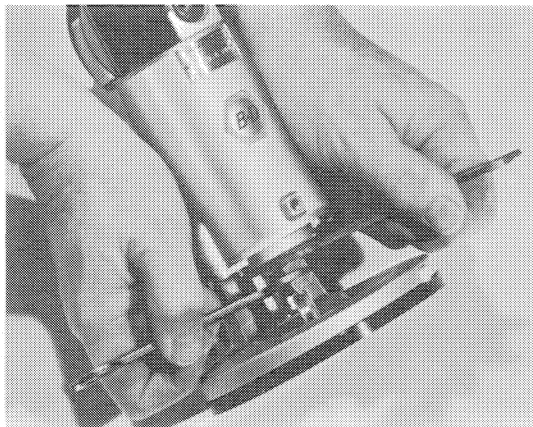

Fig. 1

### DISCONNECT POWER CORD FROM ELECTRICAL SOURCE.

Fig. 1 illustrates the router with the bit inserted in the collet. The shank of the bit or cutter should be inserted as far as possible to keep runout and deflection to a minimum. Use the two open end wrenches provided to install and remove bits. One wrench is fitted to the flats on the armature shaft and the other is used to turn the collet nut.

## OPERATING LAMINATE TRIMMER

1. A clear plastic shield is also provided to protect the operator from flying chips. Attach this shield in the position shown in Fig. 2, with the two screws supplied, before making any cuts.

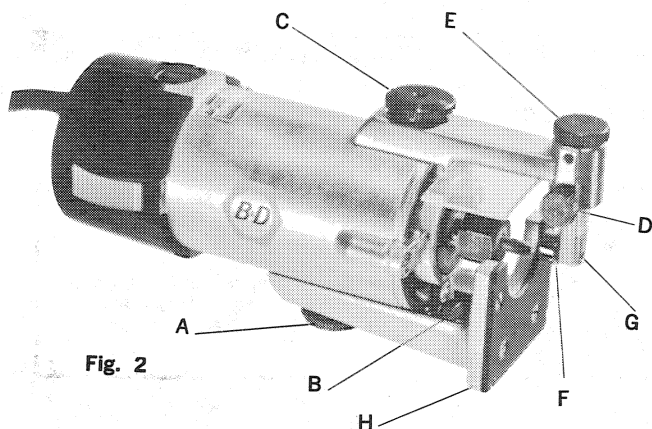

Fig. 2

## 2. Adjustments for Trimming

Loosen locking nut "A" (see Fig. 2) and rotate adjustment nut "B" to move base "H" up or down as desired. Use a steel scale or a strip of laminate against the base to aid in selecting the portion of cutting edge to be used. Changing this setting when necessary will present a fresh, sharp portion of the cutting edge, thereby prolonging the life of the bit. Retighten locking nut "A".

Loosen locking nut "C" and move edge guide in or out to position edge guide on work as desired. Retighten locking nut "C".

To adjust for depth of cut, loosen locking screw "D" and turn adjustment nut "E" until the proper depth of cut is obtained. Retighten locking screw "D".

If a flat surface appears on steel guide\* "F", loosen screw "G" so that the guide can be turned to provide a new surface, after which screw "G" should be securely tightened as steel guide "F" should not rotate.

\* A rolling Ball-Bearing Guide is also available for those who prefer it—see page 5.

## 3. Making the Trimming Cut

Grasp the tool firmly in both hands, or with one hand as you become experienced with the tool. Lower the revolving bit into the laminate until the round steel guide is in contact with the top surface, and the guide base, "H" Fig. 2 is in flush contact with the surface of the laminate—see Figs. 3 & 4.

When following curved surfaces, be sure that the Base "H" and round Steel Guide "F" are both in contact with the side and top of the work.

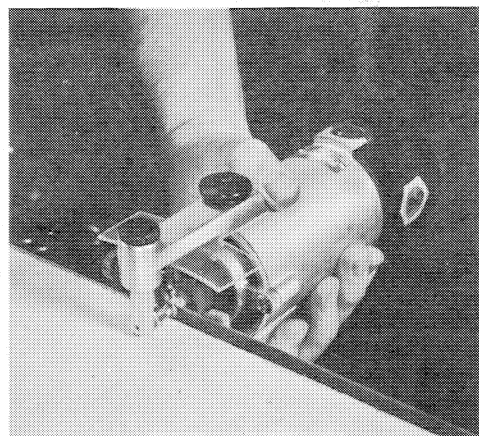

Fig. 3

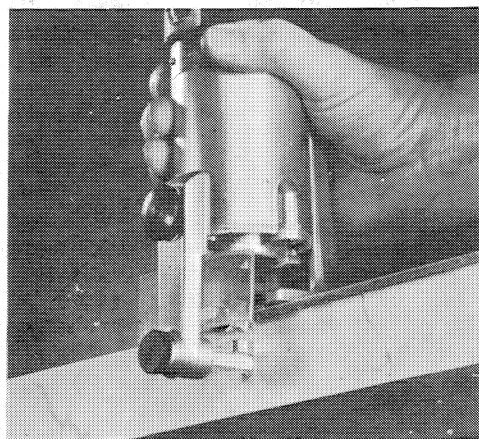
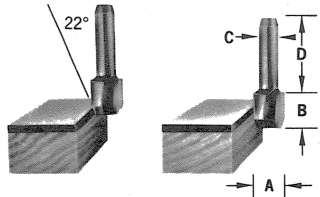

Fig. 4

# Black & Decker<sup>®</sup> CYCLONE<sup>\*</sup> ROUTER BITS

Finest quality bits for every laminate application

## TRIMMING BITS



22° Combination Veneer • Carbide Tipped • 2 Flutes

1 1/32	3/16	1/4	1
--------	------	-----	---

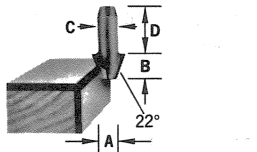

22° Bevel • Carbide Tipped • 2 Flutes

3/16	1/4	1/4	1 1/16
3/16	1/4	1/4	1

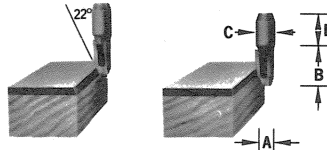

Straight & 22° Bevel • Carbide Tipped • 1 Flute

3/16	1/32	1/4	1 1/32
3/16	1/32	1/4	1 1/2

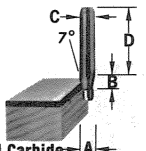

7° Bevel • Solid Carbide

3/16	1/4	1/4	1
------	-----	-----	---

Flush Trim • Solid Carbide

1/4	1/4	1/4	1
-----	-----	-----	---

\*Cyclone T M of the Black & Decker Manufacturing Company

## TRIMMING CUTTERS

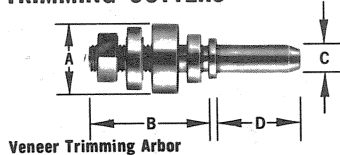

Veneer Trimming Arbor

5/8	1 1/2	1/4	1
-----	-------	-----	---

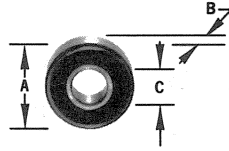

Ball Bearing Assembly

A	B	C	D
In.	In.	In.	In.
1 1/8	1/4	1/4	

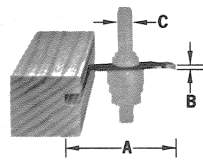

Slotting Cutters • Carbide Tipped

1 5/8	1/16	1/4
1 5/8	3/16	1/4
1 5/8	1/8	1/4
1 3/16	1/4	1/4

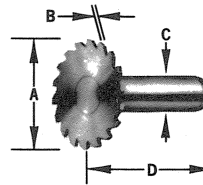

Trimming Saw • Solid Carbide

3/4	1/2	1/4	1
-----	-----	-----	---

Arbor  
Not  
Included

## Trimming Cutters cont'd.

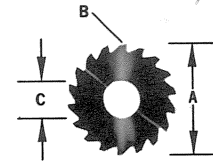

Trimming Saw • Solid Carbide

3/4	1/2	1/4
-----	-----	-----

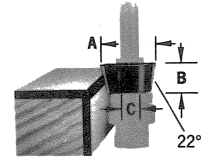

22° Bevel Trimming Cutter • Carbide Tipped

5/8	3/8	1/4
-----	-----	-----

45° Bevel Trimming Cutter • Carbide Tipped

1	1/4	1/4
---	-----	-----

Flush Trimming Cutter • Carbide Tipped

5/8	3/8	1/4
-----	-----	-----

Arbor  
Not  
Included

## ALUMINUM TRIMMING BITS

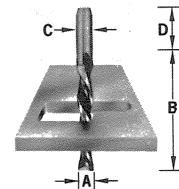

Shear Cut Bits (Down Spiral)  
HIGH SPEED STEEL

1/8	3/8	1/4	1 1/8
1/4	1	1/4	1 1/4

Shear Cut Bits (Up Spiral)  
HIGH SPEED STEEL

1/8	3/8	1/4	1 1/8
1/4	1	1/4	1 1/4
3/8	1	3/8	1 1/4

**CAUTION:** Recommended accessories for use with your tool are listed in this manual. The use of any other accessory or attachment might be hazardous.

The accessories listed in this manual are available at extra cost from your local dealer or Black & Decker Service Center. A complete listing of service centers is included on the owner's registration card packed with your tool.

If you need assistance in locating any accessory, please contact: Black & Decker (U.S.) Inc., User Services Department, 626 Hanover Pike, P.O. Box 618, Hampstead, MD 21074-0618.

### IMPORTANT!

To assure product SAFETY and RELIABILITY, repairs, maintenance and adjustment (excluding brush inspection & replacement) should be performed by BLACK & DECKER Service Centers or other qualified service organizations, always using BLACK & DECKER replacement parts.

### IMPORTANT!

## COMMERCIAL/INDUSTRIAL USE WARRANTY

Black & Decker (U.S.) Inc. warrants this product for one year from date of purchase. We will repair without charge, any defects due to faulty material or workmanship. Please return the complete unit, transportation prepaid, to any Black & Decker Service Center or Authorized Service Station, listed under "Tools Electric" in the yellow pages. This warranty does not apply to accessories or damage caused where repairs have been made or attempted by others.

**BLACK & DECKER (U.S.) INC.**  
701 E. Joppa Road, Towson, MD 21286

## Free Manuals Download Website

<http://myh66.com>

<http://usermanuals.us>

<http://www.somanuals.com>

<http://www.4manuals.cc>

<http://www.manual-lib.com>

<http://www.404manual.com>

<http://www.luxmanual.com>

<http://aubethermostatmanual.com>

Golf course search by state

<http://golfingnear.com>

Email search by domain

<http://emailbydomain.com>

Auto manuals search

<http://auto.somanuals.com>

TV manuals search

<http://tv.somanuals.com>