

Original BMW accessories. Installation Instructions.



Park Distance Control (PDC) Rear Retrofit BMW X5 (E53)

Installation instructions only valid for U.S. vehicles.

Retrofit kit No. 66 21 0 416 597 Park Distance Control (PDC) Rear Retrofit

Installation time

The installation time is 1.5 hours, but this may vary depending on the condition of the car and the equipment in it.

Important information

These installation instructions are primarily designed for use within the BMW dealership organization and by authorised BMW service companies.

In any event the target group for these installation instructions is specialist personnel trained on BMW cars with the appropriate specialist knowledge.

All work must be completed using the latest BMW repair manuals, circuit diagrams, servicing manuals and work instructions in a rational order using the prescribed tools (special tools) and observing current health and safety regulations.

To avoid unnecessary extra work and/or costs, if any installation or function problems occur, after a brief troubleshooting session (approx. 0.5 hours), an inquiry is to be sent straight away to the technical parts support via the Aftersales Assistance Portal (ASAP), quoting the chassis number, the part number of the retrofit kit and a precise description of the problem.

Do not archive the hard copy of these installation instructions since daily updates are made by ASAP.

Pictograms



Denotes instructions that draw your attention to special features.

◀ Denotes the end of the instruction or other text.

Subject to technical modifications.

Print out section 9 of these installation instructions and give it to the customer.

Installation information

Ensure that the cables/lines are not kinked or damaged as you install them in the car. The costs incurred as a result of this will not be reimbursed by BMW AG.

Additional cables/lines that you install must be secured with cable ties.

If the specified PIN chambers are occupied, bridges, double crimps or twin-lead terminals must be used.

Special tools required

None

Contents

Section	Page
1. Parts list	3
2. Preparations.....	4
3. Connection diagram.....	5
4. Installation and cabling diagram	6
5. To install the license plate holder	7
6. To install and connect the wiring harness.....	8
7. Concluding work and coding	9
8. Circuit diagram	10
9. Customer information for operating the Rear Park Distance Control (PDC).....	12

1. Parts list

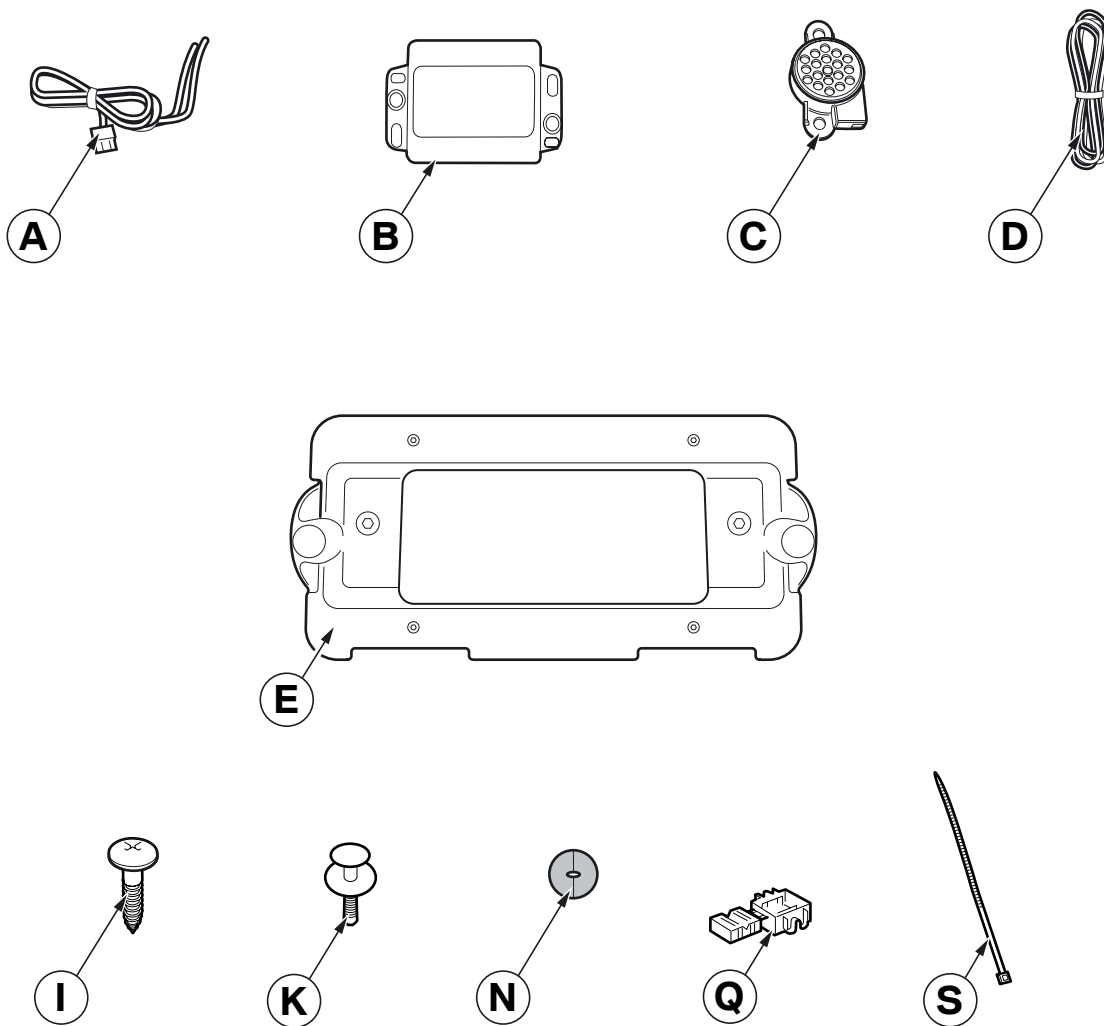

053 0824 Z

Legend

A	Wiring harness	I	Philips screw 4.8 x 15 mm (4x)
B	Control unit	K	Expanding rivet, 6 mm (4x)
C	Signal generator	N	2-piece rubber grommet
D	Signal generator cable	Q	Miniature connector (4x)
E	License plate holder	S	Cable tie 200 x 3.6 mm (20x)

 The other parts in the universal retrofit kit are not required. ◀

2. Preparations

	TIS No.
Conduct a brief test	---
Disconnect the negative pole of the battery	12 00 ...
The following components must be removed first of all	
Trunk floor trim	51 47 101
Flap in the trunk wheel arch trim on the right	51 47 172
Trim for tailgate bottom section	51 49 090
Rear license plate holder (no longer required)	---

3. Connection diagram

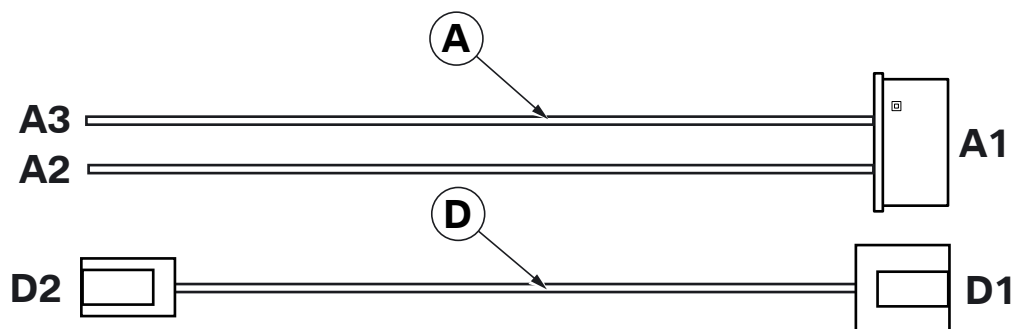

087 0199 Z

Branch/ Item	Designation	Signal	Cable color / Cross- section	Connection location in the car	Abbreviation / Slot
A	Wiring harness	---	---	---	---
A1	Black 4-pin socket casing	---	---	On control unit B	---
A2	Cable open	Terminal 31	SW 0.35 mm ²	Using miniature connector Q on joint connector terminal 31 on left of rear closing panel	X493
A3	Cable open	RFS terminal	RT 0.35 mm ²	Using miniature connector Q on white/yellow cable on grommet of tailgate bottom section	---
D	Signal generator cable	---	---	---	---
D1	Black 4-pin socket casing	---	---	On control unit B	---
D2	Black 2-pin socket casing	---	---	On signal generator C	---

4. Installation and cabling diagram

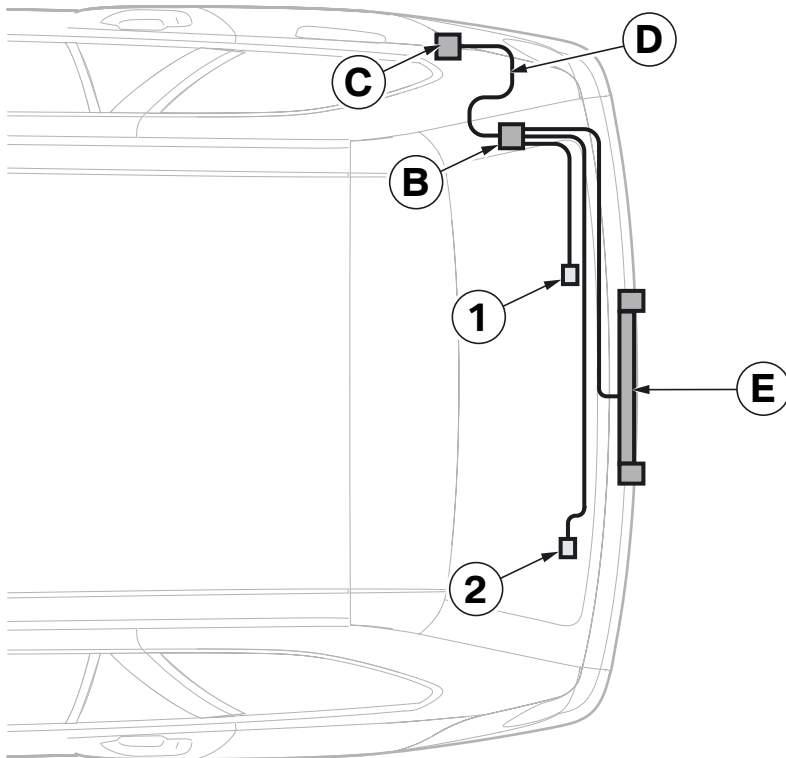

053 0825 Z

Legend

- B Control unit
 - C Signal generator
 - D Signal generator cable
 - E License plate holder
-
- 1 RFS terminal pick-up on the standard wiring harness
 - 2 Terminal 31 pick-up on joint connector **X493**

5. To install the license plate holder

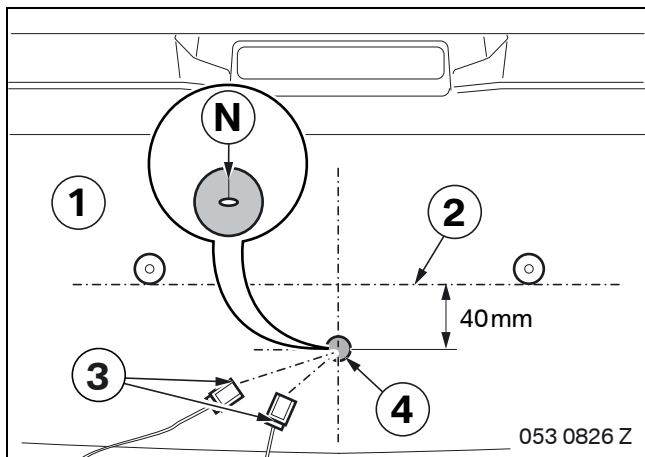

Mark the hole (4) on the tailgate bottom section (1) as follows:

- In the middle
- Approx. 40 mm from the reference line (2)

Drill through the tailgate bottom section (1) at the drilling position (4) using a 12 mm step drill bit.

Complete the anti-corrosion treatment process.

Route the sensor cable (3) through rubber grommet **N** and insert rubber grommet **N** in the tailgate bottom section (1).

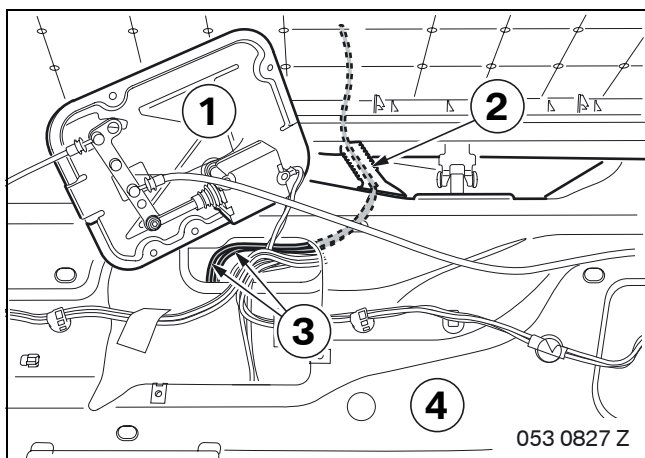

Unscrew the opener (1) of the tailgate bottom section.

Route sensor cable (3) through the grommet (2) into the trunk.

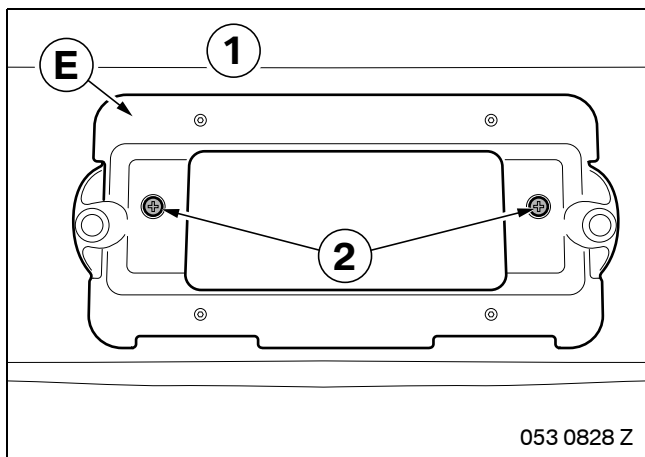

Secure license plate holder **E** to the tailgate bottom section (1) using the license plate screws (2).

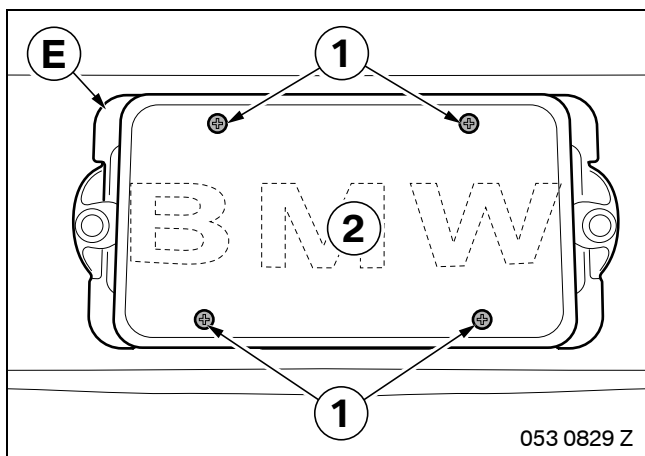

Secure the license plate (2) to license plate holder **E** using the license plate screws (1).

6. To install and connect the wiring harness

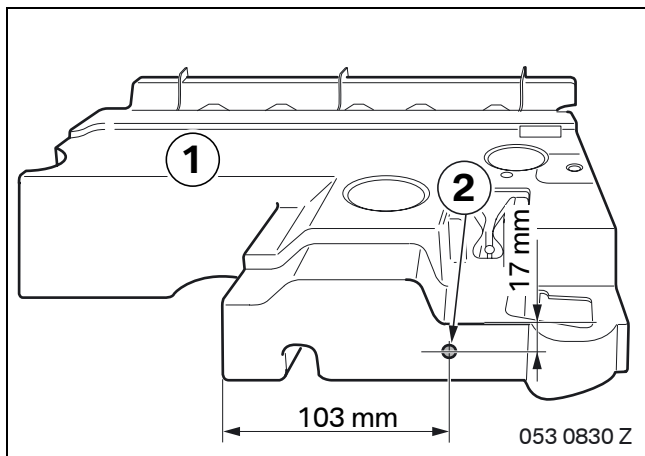

Remove the cover (1) from the right of the trunk and transfer the specified dimensions.

Drill through the cover (1) at the drilling position (2) using a 3 mm twist drill bit.

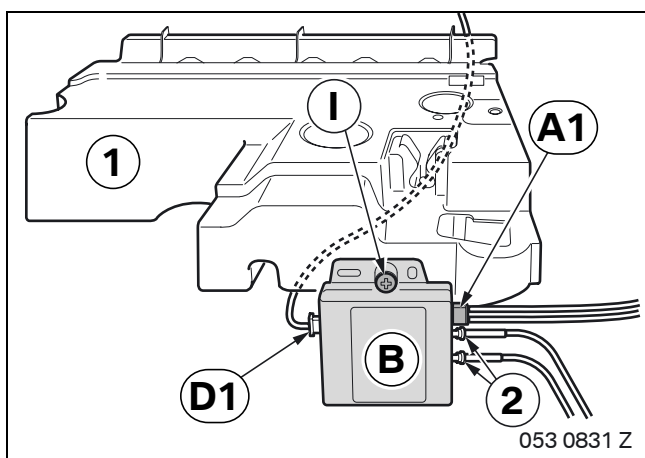

Secure control unit **B** to the cover (1) using Philips screw **I**.

Connect the sensor cable (2), branch **A1** (black 4-pin) and branch **D1** (black 4-pin) to control unit **B**.

Install the cover (1) and tie back excess lengths of the sensor cables (2).

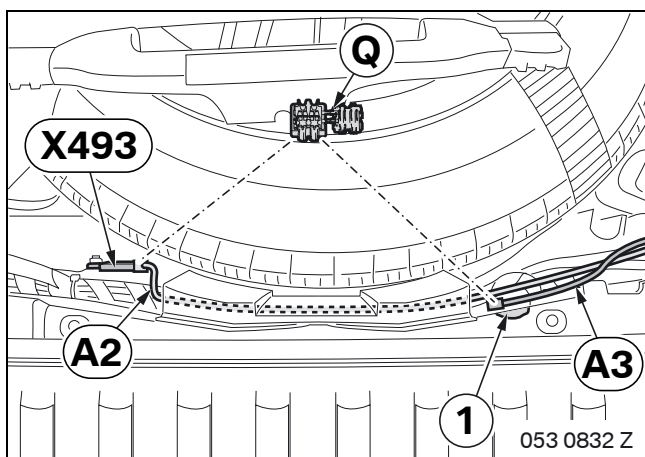

Route branch **A2**, black cable, to joint connector **X493**, brown/black cable, and connect it with miniature connector **Q**.

Route branch **A3**, red cable, to the grommet (1) on the tailgate bottom section.

 Use a multimeter to check whether the reversing light signal is present on the white/yellow cable on the grommet. ◀

Use miniature connector **Q** to connect branch **A3** to the white/yellow cable.

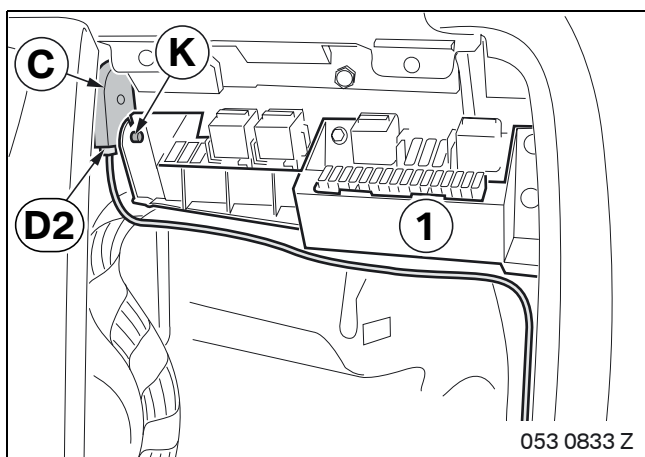

Use expanding rivet **K** to secure signal generator **C** to the existing hole in the fuse holder (1).

Route branch **D2** (black 2-pin) along the standard wiring harness to the signal generator **C** and connect it.

7. Concluding work and coding

This retrofit system does not require coding.

- Connect the battery
- Conduct a brief test
- Perform a function test of the PDC
- Re-assemble the car

8. Circuit diagram

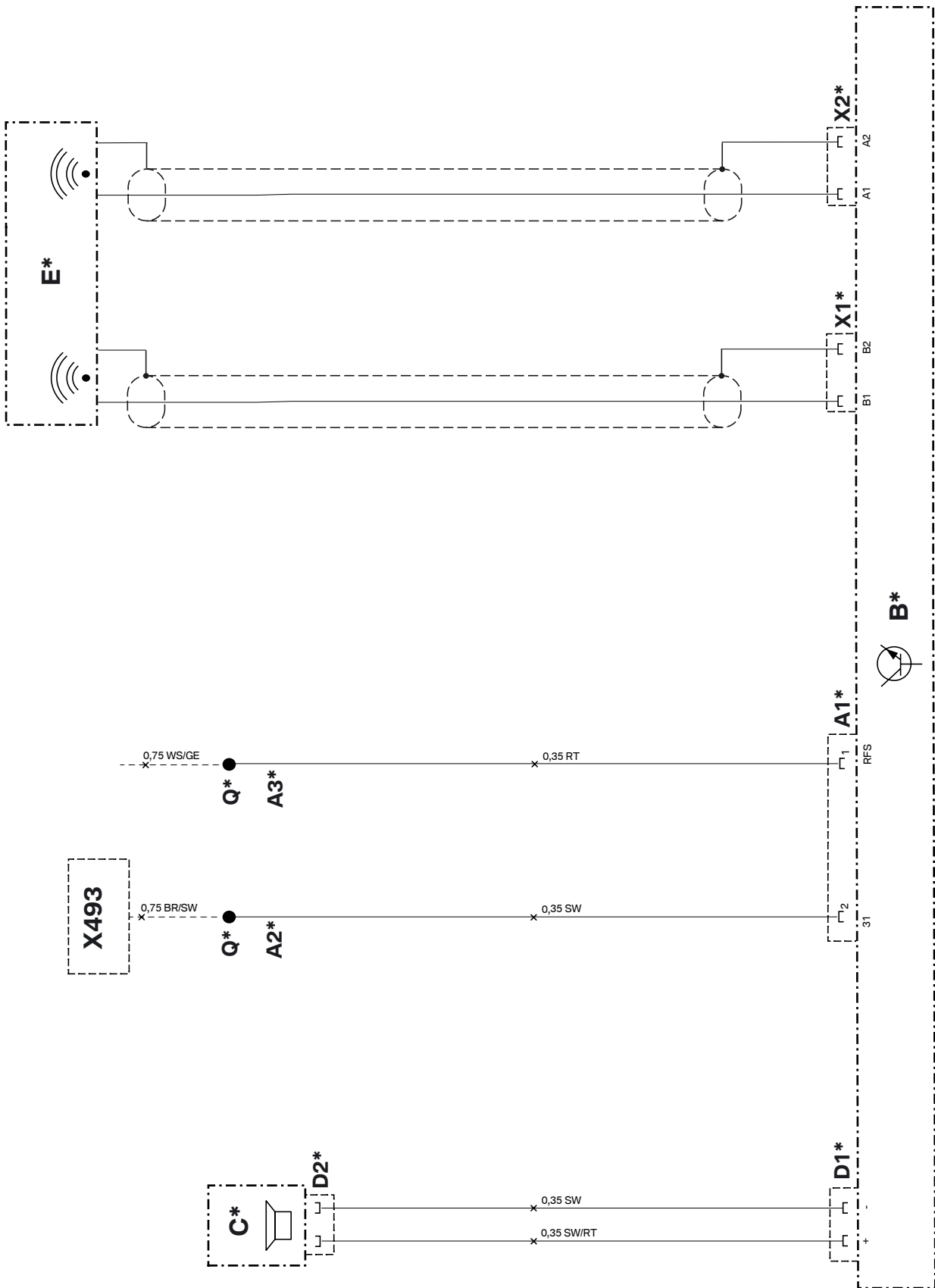

053 0834 Z

8. Circuit diagram

Legend

A1*	Black 4-pin plug
A2*	Terminal 31 pick-up
A3*	RFS terminal pick-up on the standard wiring harness
B*	Control unit
C*	Signal generator
D1*	Black 4-pin plug
D2*	Black 2-pin plug
E*	License plate holder
Q*	Miniature connector
X1*	Black 2-pin plug
X2*	Black 2-pin plug
X493	Terminal 31 joint connector

All the designations marked with an asterisk (*) apply only to these installation instructions or this circuit diagram.

Cable colors

BR	Brown
GE	Yellow
RT	Red
SW	Black
WS	White

9. Customer Information for Operating the Rear Park Distance Control (PDC)

Print out this customer information and give it to the customer.

Pictograms



Denotes instructions that draw your attention to dangers.



Denotes instructions that draw your attention to special features.

◀ Denotes the end of the instruction or other text.

Function

The PDC is a system which assists you when parking and maneuvering.

Ultrasonic sensors record the position of obstacles behind the car and inform the driver by means of acoustic signals.

Acoustic signals start when an obstacle is detected by the PDC.

The closer the car approaches the obstacle, the more rapid the acoustic signals. A permanent signal sounds when the distance to the obstacle reaches 30 cm/1 ft.

Operation

The PDC is switched on automatically as soon as reverse gear is engaged when the ignition is turned on.

The PDC is switched off automatically as soon as the ignition is turned off or reverse gear is disengaged.



Judging obstacles is exclusively the responsibility of the driver, who must drive attentively and carefully in order to avoid damaging property and injuring people. ◀



As with all ultrasonic distance measuring systems, signals may be triggered incorrectly or individual objects may not be registered sufficiently.

Due to the car, blind spots may occur in front of the bumper and at its lateral ends. Obstacles in these blind spots may not be registered sufficiently, or not at all.

The limits of what can be physically measured may be reached when encountering very low obstacles (lower than 10 cm/0,33 ft), thin obstacles (thinner than 6 cm/0,2 ft) or pointed obstacles. Such obstacles might not be registered sufficiently under certain circumstances.

To guarantee that the PDC operates properly, you should drive slowly when parking and maneuvering and also keep the ultrasonic sensors free from snow, ice or dirt.

Strong wind, falling snow or rain can trigger incorrect signals. ◀

Free Manuals Download Website

<http://myh66.com>

<http://usermanuals.us>

<http://www.somanuals.com>

<http://www.4manuals.cc>

<http://www.manual-lib.com>

<http://www.404manual.com>

<http://www.luxmanual.com>

<http://aubethermostatmanual.com>

Golf course search by state

<http://golfingnear.com>

Email search by domain

<http://emailbydomain.com>

Auto manuals search

<http://auto.somanuals.com>

TV manuals search

<http://tv.somanuals.com>