

1998

**BMW Z3 (E36/7)
Z3 Roadster
M Roadster**

Electrical

Troubleshooting

Manual

Vehicles produced 9/97 thru 8/98

PN 01 00 0 006 552



ELECTRICAL TROUBLESHOOTING MANUAL

SERIES 3 – E36/7 (Z3 Roadster and M Roadster)

SCHEMATICS

MODEL YEAR 1998

0100.0	INDEX	6135.0	DRIVE-AWAY PROTECTION (EWS II)
0110.0	INTRODUCTION	6160.1	WIPER/WASHER MODULE (WWM)
0140.0	SYMBOLS	6167.1	HEADLIGHT WASHER (SRA)
0670.0	POWER DISTRIBUTION CHART	6169.0	WINDSHIELD WASHER JET HEATERS
0670.1	FUSE CHART	6211.0	INSTRUMENT CLUSTER
0670.2	POWER DISTRIBUTION	6213.3	DIGITAL CLOCK
0670.3	FUSE DETAILS	6300.0	LIGHT SWITCH DETAILS
0670.4	GROUND DISTRIBUTION	6312.0	HEADLIGHTS/FOG LIGHTS
0670.5	DATA LINK	6313.0	TURN/HAZARD LIGHTS
1210.17	ENGINE CONTROL SYSTEM MS41.1 (6-CYLINDER M52/S52)	6314.0	PARK/TAIL/UNDERHOOD LIGHTS
1210.20	ENGINE CONTROL SYSTEM (DME M5.2, 4-CYLINDER M44)	6320.0	LICENSE PLATE/LUGGAGE COMPARTMENT LIGHTS
1230.0	CHARGING SYSTEM	6322.0	BACK UP LIGHTS
1240.0	START	6325.0	BRAKE LIGHTS
1290.0	E-BOX FAN	6330.3	INTERIOR LIGHTS
2460.2	ELECTRONIC TRANSMISSION CONTROL (EGS A4S 270R)	6332.0	INTERIOR ACCESSORIES
3234.0	SUPPLEMENTAL RESTRAINT SYSTEM (AIR BAG)	6350.0	CRASH CONTROL MODULE
3450.0	SLIP CONTROL (ABS)	6424.0	REAR WINDOW DEFOGGER
3450.1	SLIP CONTROL (ABS/ASC)	6450.6	INTEGRATED HEATING- AND CLIMATE CONTROL
3614.0	TIRE INFLATION SYSTEM	6510.1	RADIO/HIFI
5116.0	POWER MIRRORS	6561.0	CELLULAR TELEPHONE (PROVISIONS)
5126.0	ZKE CENTRAL LOCKING (ZV)	6571.0	CRUISE CONTROL (TEMPOMAT)
5133.0	ZKE POWER WINDOWS (FH)	6575.2	ANTI-THEFT SYSTEM (ALPINE)
5200.0	POWER SEATS	6581.3	BOARD COMPUTER (BC – LOW)
5203.0	HEATED SEATS	7000.0	COMPONENT LOCATION CHART
5430.2	ELECTRO-HYDRAULIC CONVERTIBLE TOP	7100.0	COMPONENT LOCATION VIEWS
6100.0	CENTRAL BODY ELECTRONICS (ZKE IV)	8000.0	SPLICE LOCATION VIEWS
6133.0	HORN	8500.0	CONNECTOR VIEWS



0100.0 INDEX

Z3

ABS HYDRAULIC UNIT, Y1	3450.0-01
ABS HYDRAULIC UNIT, Y1w	3450.1-01
ABS HYDRAULIC UNIT, Y1w	3450.1-11
ABS HYDRAULIC UNIT, Y1w	3450.1-05
ABS PUMP MOTOR RELAY, K75	3450.0-00
ABS PUMP MOTOR RELAY, K75	3450.1-00
ABS PUMP MOTOR RELAY, K75	3450.1-04
ABS RELAY, K10	3450.0-00
ABS RELAY, K10	3450.1-04
AIR BAG CUT-OFF SWITCH, PASSENGER'S, S559 ..	3234.0-01
AIR BAG GAS GENERATOR, DRIVER'S, G5	3234.0-00
AIR BAG GAS GENERATOR, LEFT SIDE, G14	3234.0-03
AIR BAG GAS GENERATOR, PASSENGER'S, G6	3234.0-01
AIR BAG GAS GENERATOR, RIGHT SIDE, G15	3234.0-03
AIR CONDITIONING COMPRESSOR, Y2	6450.6-02
AIR CONDITIONING COMPRESSOR, Y2	6450.6-07
AIR CONDITIONING RELAY, MOTRONIC, K33a	6450.6-05
AIR CONDITIONING/ RECIRCULATING SWITCH ASSEMBLY, S220	6450.6-01
AIR CONDITIONING/ RECIRCULATING SWITCH ASSEMBLY, S220	6450.6-06
AIR PUMP, Y6133	1210.20-09
AIR PUMP, Y6163	1210.17-05
ANALOG CLOCK, N5	6211.0-07
ANTENNA AMPLIFIER AM/FM, N8	6510.1-00
ANTI-THEFT CONTROL MODULE (ALPINE), N12w	6575.2
ANTI-THEFT HORN (ALPINE), H1w	6575.2-01
ANTI-THEFT SYSTEM (ALPINE)	6575.2

ASC DIODE, V7	3450.1-04
ASC SWITCH, S6	3450.1-12
ASC SWITCH, S6	3450.1-03
ASC SWITCH, S6	3450.1-06
ASHTRAY LIGHT, FRONT, E25	6300.0-01
ASHTRAY LIGHT, FRONT, E25	6332.0-00
AUTOMATIC TRANSMISSION RANGE SWITCH, S3 ...	2460.2-08
AUXILIARY FAN MOTOR, M9	6450.6-03
AUXILIARY FAN MOTOR, M9	6450.6-04
AUXILIARY FAN MOTOR, M9	6450.6-08
AUXILIARY FUSE BOX, P95	0670.2-02
AUXILIARY FUSE BOX, P97	0670.2-02
AUXILIARY THROTTLE POSITION MOTOR (ADS), M93	3450.1-09
AUXILIARY THROTTLE POSITION MOTOR (ADS), M93	3450.1-03
AUXILIARY THROTTLE POSITION MOTOR (ADS), M93	3450.1-06
AUXILIARY THROTTLE POSITION SENSOR, R31	3450.1-09
AUXILIARY THROTTLE POSITION SENSOR, R31	3450.1-03
AUXILIARY THROTTLE POSITION SENSOR, R31	3450.1-08
AUXILIARY TURN LIGHT, LEFT FRONT, H9	6313.0-02
AUXILIARY TURN LIGHT, RIGHT FRONT, H8	6313.0-02
B+ JUMP START JUNCTION POINT, G6430	0670.2-00
B+ JUMP START JUNCTION POINT, G6430	0670.2-01
BACK UP LIGHT, LEFT, H27	6322.0-00
BACK UP LIGHT, RIGHT, H28	6322.0-00
BACK UP LIGHTS	6322.0-00
BATTERY, G1	0670.2-00
BATTERY, G1	0670.2-01
BLOWER MOTOR, M30	6450.6-00



INDEX

Z3

BLOWER MOTOR, M30	6450.6-05
BLOWER RELAY, K4	6450.6-00
BLOWER RELAY, K4	6450.6-05
BLOWER RESISTORS, R11	6450.6-00
BLOWER RESISTORS, R11	6450.6-05
BLOWER SWITCH, S75	6450.6-00
BLOWER SWITCH, S75	6450.6-05
BOARD COMPUTER (BC – LOW)	6581.3-00
BOARD COMPUTER (BC – LOW), A35y	6581.3-00
BODY ELECTRONICS CONTROL MODULE (ZKE IV), A104	6100.0
BRAKE FLUID LEVEL SWITCH, B18	6211.0-00
BRAKE LIGHT SWITCH, S30	6325.0
BRAKE LIGHT, LEFT, H24	6325.0
BRAKE LIGHT, RIGHT, H31	6325.0
BRAKE LIGHTS	6325.0
BRAKE PAD SENSOR, LEFT FRONT, B16	6211.0-01
BRAKE PAD SENSOR, RIGHT REAR, B17	6211.0-01
CAMSHAFT POSITION SENSOR (CYLINDER IDENTIFICATION), B6204	1210.17-06
CD CHANGER, N22	6510.1
CELLULAR TELEPHONE (PROVISIONS)	6561.0-00
CENTRAL BODY ELECTRONICS (ZKE IV)	6100.0
CHARCOAL FILTER SHUT-OFF VALVE, B6247	1210.17-04
CHARCOAL FILTER SHUT-OFF VALVE, B6247	1210.20-02
CHARGING SYSTEM	1230.0-00
CHIME MODULE, H10	6211.0-06
CIGAR LIGHTER CONNECTION, E28a	3614.0-00

CIGAR LIGHTER LIGHT, FRONT, E29	6300.0-01
CIGAR LIGHTER LIGHT, FRONT, E29	6332.0-00
CIGAR LIGHTER, FRONT, E28	6332.0-00
CLUTCH SWITCH, S32	6571.0-01
COMBINATION SWITCH, S7	6313.0-00
COMPONENT LOCATION CHART	7000.0
COMPONENT LOCATION VIEWS	7100.0
COMPRESSOR CONTROL RELAY, K19	6450.6-02
COMPRESSOR CONTROL RELAY, K19	6450.6-07
COMPRESSOR MAIN SWITCH, S232	3614.0-00
COMPRESSOR RELAY, K6394	3614.0-00
CONNECTOR VIEWS	8500.0
CONTACT RING, C101	3234.0-00
CONVERTIBLE TOP ACTUATING SWITCH, S143	5430.2-01
CONVERTIBLE TOP END-POSITION MICRO SWITCH, S164	5430.2-01
CONVERTIBLE TOP MOTOR, M101	5430.2-00
CONVERTIBLE TOP RELAY I (CLOSE), K18363	5430.2-00
CONVERTIBLE TOP RELAY II (OPEN), K18364	5430.2-00
CRANKSHAFT POSITION/RPM SENSOR, B6203	1210.17-06
CRANKSHAFT POSITION/RPM SENSOR, B6203	1210.20-04
CRASH CONTROL MODULE	6350.0
CRASH CONTROL MODULE, N17	6350.0-01
CRUISE CONTROL (TEMPOMAT)	6571.0
CRUISE CONTROL ACTUATOR (TEMPOMAT), M25	6571.0-01
CRUISE CONTROL MODULE (TEMPOMAT), A8	6571.0
CRUISE CONTROL SWITCH, S28	6571.0-00
DATA LINK	0670.5



INDEX

Z3

DATA LINK CONNECTOR, D100	0670.5
DEFOGGER I, REAR, E9	6424.0
DIGITAL CLOCK	6213.3-00
DIGITAL CLOCK, A110	6213.3-00
DOOR JAMB SWITCH, DRIVER'S, S14	5126.0-01
DOOR JAMB SWITCH, PASSENGER'S, S13	5126.0-01
DOOR LOCK MOTOR, DRIVER'S, M12	5126.0-02
DOOR LOCK MOTOR, PASSENGER'S, M13	5126.0-02
DOOR LOCK SWITCH, DRIVER'S, S47	5126.0-00
DOOR LOCK SWITCH, PASSENGER'S, S49	5126.0-00
DOUBLE TEMPERATURE SWITCH, S36y	6450.6-04
DRIVE-AWAY PROTECTION (EWS II)	6135.0
DUAL TEMPERATURE SENSOR (COOLANT TEMPERATURE), B6256	1210.17-02
E-BOX FAN	1290.0-00
E-BOX FAN, M6506	1290.0-00
ELECTRICAL COMPRESSOR, M805	3614.0-00
ELECTRO-HYDRAULIC CONVERTIBLE TOP	5430.2
ELECTRONIC IMMOBILIZER CONTROL MODULE (EWS II), A836	6135.0
ELECTRONIC TRANSMISSION CONTROL (EGS A4S 270R)	2460.2
ENGINE CONTROL MODULE (DME), A6000	1210.17
ENGINE CONTROL MODULE (DME), A6000	1210.20
ENGINE CONTROL MODULE RELAY, K6300	1210.17-00
ENGINE CONTROL MODULE RELAY, K6300	1210.20-00
ENGINE CONTROL RELAY (ABS/ASC), K94	3450.1-10

ENGINE CONTROL SYSTEM (DME M5.2, 4-CYLINDER M44)	1210.20
ENGINE CONTROL SYSTEM MS41.1 (6-CYLINDER M52/S52)	1210.17
ENGINE COOLANT TEMPERATURE SENSOR, B6232	1210.17-02
ENGINE COOLANT TEMPERATURE SENSOR, B6232	1210.20-05
ENGINE COOLANT TEMPERATURE SENSOR, B6232	6211.0-02
ENGINE COOLANT TEMPERATURE SENSOR, B6236	1210.17-02
ENGINE HOOD SWITCH, S21w	6575.2-00
EVAPORATIVE EMISSION VALVE, Y6120	1210.17-05
EVAPORATIVE EMISSION VALVE, Y6120	1210.20-01
EVAPORATOR CONTROLLER, S221	6450.6-01
EVAPORATOR CONTROLLER, S221	6450.6-06
EVAPORATOR TEMPERATURE SENSOR, B14	6450.6-01
EVAPORATOR TEMPERATURE SENSOR, B14	6450.6-06
FOG LIGHT RELAY, FRONT, K47	6312.0-00
FOG LIGHT SWITCH, S10	6312.0-00
FOG LIGHT, LEFT, E26	6312.0-00
FOG LIGHT, RIGHT, E27	6312.0-00
FRESH AIR RECIRCULATION MOTOR, M111	6450.6-01
FRESH AIR RECIRCULATION MOTOR, M111	6450.6-06
FUEL CHANGEOVER VALVE, Y6263	1210.20-09
FUEL INJECTION VALVE, CYL. 1, Y6101	1210.17-01
FUEL INJECTION VALVE, CYL. 1, Y6101	1210.20-01
FUEL INJECTION VALVE, CYL. 2, Y6102	1210.17-01
FUEL INJECTION VALVE, CYL. 2, Y6102	1210.20-01
FUEL INJECTION VALVE, CYL. 3, Y6103	1210.17-01
FUEL INJECTION VALVE, CYL. 3, Y6103	1210.20-01



INDEX

Z3

FUEL INJECTION VALVE, CYL. 4, Y6104	1210.17-01
FUEL INJECTION VALVE, CYL. 4, Y6104	1210.20-01
FUEL INJECTION VALVE, CYL. 5, Y6105	1210.17-01
FUEL INJECTION VALVE, CYL. 6, Y6106	1210.17-01
FUEL PUMP RELAY, K6301w	1210.17-10
FUEL PUMP RELAY, K6301w	1210.17-11
FUEL PUMP RELAY, K6301w	1210.20-02
FUEL PUMP, M2	1210.17-10
FUEL PUMP, M2	1210.17-11
FUEL PUMP, M2	1210.20-02
FUEL SENSOR, B6y	6211.0-05
FUEL TANK PRESSURE SENSOR, B65	1210.17-04
FUEL TANK PRESSURE SENSOR, B65	1210.20-05
FUSE CHART	0670.1
FUSE DETAILS	0670.3
GEAR SHIFT LEVER INDICATOR, E96	6300.0-01
GENERATOR, G6509	1230.0
GROUND DISTRIBUTION	0670.4
HALL EFFECT CAMSHAFT SENSOR, B6209	1210.20-04
HARD TOP CONNECTOR 1, E99	6424.0
HAZARD FLASHER RELAY, K16	6313.0-00
HAZARD SWITCH, S18	6313.0-01
HEADLIGHT WASHER (SRA)	6167.1-00
HEADLIGHT, LEFT, E7	6312.0-01
HEADLIGHT, RIGHT, E8	6312.0-01
HEADLIGHT/FOG LIGHT WASHER PUMP, M7	6160.1-00
HEADLIGHT/FOG LIGHT WASHER PUMP, M7	6167.1-00
HEADLIGHTS/FOG LIGHTS	6312.0

HEAT/A/C CONTROL PANEL ILLUMINATION, E105	6300.0-02
HEAT/A/C CONTROL PANEL ILLUMINATION, E105	6300.0-03
HEAT/A/C CONTROL PANEL ILLUMINATION, E106	6300.0-02
HEAT/A/C CONTROL PANEL ILLUMINATION, E106	6300.0-03
HEATED SEATS	5203.0
HIFI AMPLIFIER, A18	6510.1
HIGH BEAM LIGHT RELAY, K46	6312.0-01
HIGH BEAM LIGHT, LEFT, E11	6312.0-01
HIGH BEAM LIGHT, RIGHT, E12	6312.0-01
HIGH LEVEL STOP LIGHT, H34	6325.0
HIGH RANGE SPEAKER, LEFT FRONT, H59	6510.1-01
HIGH RANGE SPEAKER, RIGHT FRONT, H50	6510.1-02
HIGH SPEED RELAY, K22	6450.6-03
HIGH SPEED RELAY, K22	6450.6-04
HIGH SPEED RELAY, K22	6450.6-08
HORN	6133.0-00
HORN RELAY, K2	6133.0-00
HORN SWITCH, S4	6133.0-00
HORN, LEFT, H2	6133.0-00
HORN, RIGHT, H3	6133.0-00
HOT FILM AIR MASS METER, B6207	1210.17-05
HOT FILM AIR MASS METER, B6217	1210.20-06
IDLE SPEED CONTROL VALVE, Y6130	1210.17-01
IDLE SPEED CONTROL VALVE, Y6130	1210.20-01
IGNITION COIL, CYL. 1, T6151	1210.17-03
IGNITION COIL, CYL. 1, T6151	1210.20-03
IGNITION COIL, CYL. 2, T6152	1210.17-03
IGNITION COIL, CYL. 2, T6152	1210.20-03



INDEX

Z3

IGNITION COIL, CYL. 3, T6153	1210.17-03
IGNITION COIL, CYL. 3, T6153	1210.20-03
IGNITION COIL, CYL. 4, T6154	1210.17-03
IGNITION COIL, CYL. 4, T6154	1210.20-03
IGNITION COIL, CYL. 5, T6155	1210.17-03
IGNITION COIL, CYL. 6, T6156	1210.17-03
IGNITION SWITCH, S2	0670.2-04
INDEX	0100.0
INSTRUMENT CLUSTER	6211.0
INSTRUMENT CLUSTER, A2w	6211.0
INTAKE AIR RESONANCE CHANGEOVER VALVE, Y6131	1210.20-01
INTAKE AIR TEMPERATURE SENSOR, B6205	1210.17-02
INTAKE AIR TEMPERATURE SENSOR, B6205	1210.20-05
INTEGRATED HEATING- AND CLIMATE CONTROL	6450.6
INTERIOR ACCESSORIES	6332.0-00
INTERIOR LIGHT SWITCH, S408	6330.3-00
INTERIOR LIGHT, FRONT LEFT, E800	6330.3-00
INTERIOR LIGHTS	6330.3-00
INTERMEDIATE PRESSURE SWITCH, B9	6450.6-03
INTERMEDIATE PRESSURE SWITCH, B9	6450.6-04
INTERMEDIATE PRESSURE SWITCH, B9	6450.6-08
INTRODUCTION	0110.0
JET HEATER THERMOSWITCH, S198	6169.0-00
JUMPER PLUG, B900	6571.0-01
KICK-DOWN SWITCH, S8507	2460.2-02
KICK-DOWN SWITCH, S8507	2460.2-06
KNOCK SENSOR, B6240	1210.17-06

KNOCK SENSOR, B6240	1210.20-05
LICENSE PLATE LIGHT, LEFT, E43	6320.0-00
LICENSE PLATE LIGHT, RIGHT, E44	6320.0-00
LICENSE PLATE/LUGGAGE COMPARTMENT LIGHTS	6320.0-00
LIGHT ASSEMBLY, LEFT REAR, E16	0670.4-13
LIGHT ASSEMBLY, RIGHT REAR, E17	0670.4-13
LIGHT SWITCH DETAILS	6300.0
LIGHT SWITCH, S8	6300.0-00
LOW BEAM LIGHT RELAY, K48	6312.0-01
LOW BEAM LIGHT, LEFT, E13	6312.0-01
LOW BEAM LIGHT, RIGHT, E14	6312.0-01
LOW RANGE SPEAKER, LEFT FRONT, H58	6510.1-02
LOW RANGE SPEAKER, RIGHT FRONT, H51	6510.1-02
LUGGAGE COMPARTMENT LIGHT SWITCH, S826 ...	6320.0-00
LUGGAGE COMPARTMENT LIGHT, E32	6320.0-00
LUGGAGE COMPARTMENT LOCK MOTOR, M17	5126.0-03
MARKER LIGHT, LEFT FRONT, E21	6314.0-01
MARKER LIGHT, RIGHT FRONT, E22	6314.0-01
MID-HIGH RANGE SPEAKER, REAR LEFT, H55z	6510.1-01
MID-HIGH RANGE SPEAKER, REAR RIGHT, H54z ...	6510.1-01
MIDRANGE SPEAKER, LEFT FRONT, H55	6510.1-01
MIDRANGE SPEAKER, RIGHT FRONT, H54	6510.1-02
MIRROR CONTROL SWITCH, S17	5116.0-00
MIRROR, DRIVER'S SIDE, Y5	5116.0-01
MIRROR, PASSENGER'S SIDE, Y6	5116.0-01
NORMAL SPEED RELAY, K21	6450.6-03
NORMAL SPEED RELAY, K21	6450.6-04
NORMAL SPEED RELAY, K21	6450.6-08



INDEX

Z3

OBD II CONNECTOR, D110	0670.5-05
OIL PRESSURE SWITCH, B6231	6211.0-02
OIL TEMPERATURE GAUGE, B59	6211.0-07
OIL TEMPERATURE SENSOR, B6238	6211.0-07
ON-BOARD COMPUTER TEMPERATURE SENSOR, B21	6581.3-00
OXYGEN SENSOR (BEHIND CATALYTIC CONVERTER), B62002	1210.20-04
OXYGEN SENSOR (BEHIND CATALYTIC CONVERTER), B6220y	1210.17-10
OXYGEN SENSOR (IN FRONT OF CATALYTIC CONVERTER), B62001 ..	1210.20-04
OXYGEN SENSOR (IN FRONT OF CATALYTIC CONVERTER), B6210y ..	1210.17-10
OXYGEN SENSOR I (BEHIND CATALYTIC CONVERTER), B62102	1210.17-11
OXYGEN SENSOR I (IN FRONT OF CATALYTIC CONVERTER), B62101 ..	1210.17-11
OXYGEN SENSOR II (BEHIND CATALYTIC CONVERTER), B62202	1210.17-11
OXYGEN SENSOR II (IN FRONT OF CATALYTIC CONVERTER), B62201 ..	1210.17-11
PARK BRAKE SWITCH, S31	6211.0-00
PARK LIGHT, LEFT, E15	6314.0-01
PARK LIGHT, RIGHT, E19	6314.0-01
PARK/TAIL/UNDERHOOD LIGHTS	6314.0
POWER DISTRIBUTION	0670.2
POWER DISTRIBUTION BOX, FRONT, P90	0670.2
POWER DISTRIBUTION CHART	0670.0

POWER MIRRORS	5116.0
POWER SEATS	5200.0
POWER WINDOW SWITCH, DRIVER'S, S126y	5133.0-01
POWER WINDOW SWITCH, PASSENGER'S, S127y ...	5133.0-01
PRESSURE SWITCH, B8y	6450.6-03
PRESSURE SWITCH, B8y	6450.6-04
PRESSURE SWITCH, B8y	6450.6-08
PRESSURE SWITCH, B9508	6450.6-03
PRESSURE SWITCH, B9508	6450.6-04
PRESSURE SWITCH, B9508	6450.6-08
PROGRAM SWITCH, S8503	2460.2-03
PROGRAM SWITCH, S8503	2460.2-07
PYROTECHNICAL BELT TENSIONER, DRIVER'S SIDE, G12	3234.0-00
PYROTECHNICAL BELT TENSIONER, PASSENGER'S SIDE, G13	3234.0-00
RADIO ANTI-THEFT SWITCH, S20w	6575.2-00
RADIO, N9	6510.1
RADIO/HIFI	6510.1
REVERSING LIGHT SWITCH, S8511	6322.0-00
SEAT BELT SWITCH, DRIVER'S, S58	3234.0-02
SEAT BELT SWITCH, PASSENGER'S, S59	3234.0-02
SEAT CONTROL SWITCH, DRIVER'S SEAT, S51	5200.0-00
SEAT CONTROL SWITCH, DRIVER'S SEAT, S51	5200.0-02
SEAT CONTROL SWITCH, PASSENGER'S SEAT, S56 ..	5200.0-01
SEAT CONTROL SWITCH, PASSENGER'S SEAT, S56 ..	5200.0-03
SEAT HEATER SWITCH, DRIVER'S SEAT, S53	5203.0
SEAT HEATER SWITCH, PASSENGER'S SEAT, S54	5203.0



INDEX

Z3

SEAT HEATER, DRIVER'S, E57	5203.0
SEAT HEATER, PASSENGER'S, E58	5203.0
SEAT HEIGHT MOTOR, DRIVER'S, M52	5200.0-00
SEAT HEIGHT MOTOR, DRIVER'S, M52	5200.0-02
SEAT HEIGHT MOTOR, PASSENGER'S, M59	5200.0-01
SEAT HEIGHT MOTOR, PASSENGER'S, M59	5200.0-03
SEAT LENGTH ADJUST CUT-OFF RELAY, DRIVER'S, K921	5200.0-02
SEAT LENGTH ADJUST CUT-OFF RELAY, PASSENGER'S, K911	5200.0-03
SEAT LIMIT SWITCH, DRIVER'S, S910	5200.0-02
SEAT LIMIT SWITCH, PASSENGER'S, S911	5200.0-03
SEAT MAT, I1008	3234.0-01
SEAT MOVEMENT MOTOR, DRIVER'S, M51	5200.0-00
SEAT MOVEMENT MOTOR, DRIVER'S, M51	5200.0-02
SEAT MOVEMENT MOTOR, PASSENGER'S, M60	5200.0-01
SEAT MOVEMENT MOTOR, PASSENGER'S, M60	5200.0-03
SEAT OCCUPANCY DETECTOR, A113	3234.0-01
SEAT TILT ADJUST CUT-OFF RELAY, DRIVER'S, K920	5200.0-02
SEAT TILT ADJUST CUT-OFF RELAY, PASSENGER'S, K910	5200.0-03
SEATBACK HEATER, DRIVER'S, E56	5203.0
SEATBACK HEATER, PASSENGER'S, E59	5203.0
SECONDARY AIR PUMP RELAY, K6304	1210.17-05
SECONDARY AIR PUMP RELAY, K6304	1210.20-09
SECONDARY AIR PUMP VALVE, Y6163	1210.17-05
SECONDARY AIR PUMP VALVE, Y6163	1210.20-09
SHIFT-LOCK, Y19	2460.2-02

SHIFT-LOCK, Y19	2460.2-05
SIDE IMPACT SENSOR, DRIVER'S, B78	3234.0-03
SIDE IMPACT SENSOR, PASSENGER'S, B79	3234.0-03
SLIP CONTROL (ABS)	3450.0
SLIP CONTROL (ABS/ASC)	3450.1
SLIP CONTROL MODULE (ABS), A7	3450.0-00
SLIP CONTROL MODULE (ABS/ASC), A52	3450.1
SOLENOID VALVE ("RUNNING LOSSES"), Y6550	1210.17-05
SPEED SENSOR - ABS, LEFT FRONT, B2	3450.1-13
SPEED SENSOR - ABS, LEFT FRONT, B2	3450.0-02
SPEED SENSOR - ABS, LEFT FRONT, B2	3450.1-02
SPEED SENSOR - ABS, LEFT FRONT, B2	3450.1-07
SPEED SENSOR - ABS, LEFT REAR, B4	3450.1-13
SPEED SENSOR - ABS, LEFT REAR, B4	3450.0-02
SPEED SENSOR - ABS, LEFT REAR, B4	3450.1-02
SPEED SENSOR - ABS, LEFT REAR, B4	3450.1-07
SPEED SENSOR - ABS, RIGHT FRONT, B1	3450.1-13
SPEED SENSOR - ABS, RIGHT FRONT, B1	3450.0-02
SPEED SENSOR - ABS, RIGHT FRONT, B1	3450.1-02
SPEED SENSOR - ABS, RIGHT FRONT, B1	3450.1-07
SPEED SENSOR - ABS, RIGHT REAR, B3	3450.1-13
SPEED SENSOR - ABS, RIGHT REAR, B3	3450.0-02
SPEED SENSOR - ABS, RIGHT REAR, B3	3450.1-02
SPEED SENSOR - ABS, RIGHT REAR, B3	3450.1-07
SPLICE LOCATION VIEWS	8000.0
START	1240.0
STARTER IMMOBILIZATION SWITCH, S235	1240.0-00
STARTER, M6510	1240.0-01

04/99

0100.0-06

1998



INDEX

Z3

SUPPLEMENTAL RESTRAINT SYSTEM (AIR BAG)	3234.0
SUPPLEMENTAL RESTRAINT SYSTEM CONTROL MODULE, A12	3234.0
SYMBOLS	0140.0
TAIL LIGHT, LEFT, H25	6314.0-01
TAIL LIGHT, LEFT, H37	6314.0-01
TAIL LIGHT, RIGHT, H30	6314.0-01
TAIL LIGHT, RIGHT, H39	6314.0-01
TEMPERATURE SWITCH, S36	6450.6-03
TEMPERATURE SWITCH, S36	6450.6-08
TEMPERATURE WHEEL SWITCH, S531	6450.6-01
TEMPERATURE WHEEL SWITCH, S531	6450.6-06
THROTTLE POSITION SENSOR, R6252	1210.17-05
THROTTLE POSITION SENSOR, R6252	1210.20-05
TIRE INFLATION SYSTEM	3614.0-00
TRANSMISSION CONTROL MODULE (EGS), A8500	2460.2
TRANSMISSION POSITION INDICATOR LIGHT, E82 ..	6300.0-02
TRANSMISSION VALVE UNIT, Y8505y	2460.2-05
TRANSMISSION VALVE UNIT, Y8521	2460.2-01
TRANSMITTER MODULE (EWS II), A835	6135.0-00
TURN LIGHT, LEFT FRONT, H7	6313.0-02
TURN LIGHT, LEFT REAR, H6	6313.0-03
TURN LIGHT, RIGHT FRONT, H4	6313.0-02
TURN LIGHT, RIGHT REAR, H5	6313.0-03
TURN/HAZARD LIGHTS	6313.0
UNLOADER RELAY, TERMINAL 15, K6326	1210.17-02
UNLOADER RELAY, TERMINAL 15, K6326	1210.20-02
UNLOADER RELAY, TERMINAL 15, K9	5203.0-00

UNLOADER RELAY, TERMINAL 15, K9	6424.0-01
VALVE RELAY (ABS/ASC), K95	3450.1-10
VARIABLE CAMSHAFT CONTROL VALVE 1, Y6275 ..	1210.17-01
VEHICLE SPEED SENSOR, B10	6211.0-05
WASHER JET HEATER, LEFT, E51	6169.0-00
WASHER JET HEATER, RIGHT, E52	6169.0-00
WASHER PUMP, M4	6160.1-01
WASHER PUMP, M4	6160.1-02
WATER VALVE, Y4z	6450.6-01
WATER VALVE, Y4z	6450.6-06
WINDOW DEFOGGER SWITCH, REAR, S76	6424.0
WINDOW DEFOGGER, REAR	6424.0
WINDOW MOTOR, DRIVER'S, M21	5133.0-02
WINDOW MOTOR, PASSENGER'S, M23	5133.0-02
WINDSHIELD WASHER JET HEATERS	6169.0-00
WIPER MOTOR, M3	6160.1-00
WIPER MOTOR, M3	6160.1-02
WIPER/WASHER MODULE (LOW II), A64	6160.1-02
WIPER/WASHER MODULE (WWM)	6160.1
WIPER/WASHER MODULE, A51	6160.1
WIPER/WASHER MODULE, A51	6167.1-00
WIPER/WASHER SWITCH, S5	6160.1-01
WIPER/WASHER SWITCH, S5	6160.1-02
WOOFER, REAR, H500	6510.1-01
ZKE CENTRAL LOCKING (ZV)	5126.0
ZKE POWER WINDOWS (FH)	5133.0

Schematics

The schematics divide the entire vehicle electrical system into individual circuits. Interacting electrical components are shown on one common schematic.

Switches and other components are represented in such a way that their general layout and function are self-explicit. They are arranged on the sheet such that the current path can be followed from positive (top) to negative (bottom).

Important: The components and wires are not drawn to scale. For instance, a lead with a length of over 1m can be shown as a lead that is only a few cm long. To ensure clear arrangement, all connectors, line branches and connected components from the fuses to the component and from the component to ground connection are not shown within the individual cells. If required, reference can be made to cells **0670.3 Fuse Details** and **0670.4 Ground Distribution** where all lines are illustrated with all plug connections, line branches and connected components.

All circuit symbols used are listed and explained in cell **0140.0 Symbols**.

In cell **7000.0 Component Location Chart** all important connectors, ground points and components are listed in tabular form. It provides a precise description of the component locations in the vehicle.

In cell **7100.0 Component Location Views** the location of connectors and components which are difficult to locate are shown in line arts or illustrations. In cell **8000.0 Splice Location Views** all splices are listed in numerical order and illustrations are provided to assist in locating splices on larger harnesses. In cell **8500.0 Connector Views** diagrams of connectors with more than 2 pins are illustrated.

Example

General conventions can be explained based on the following schematic example.

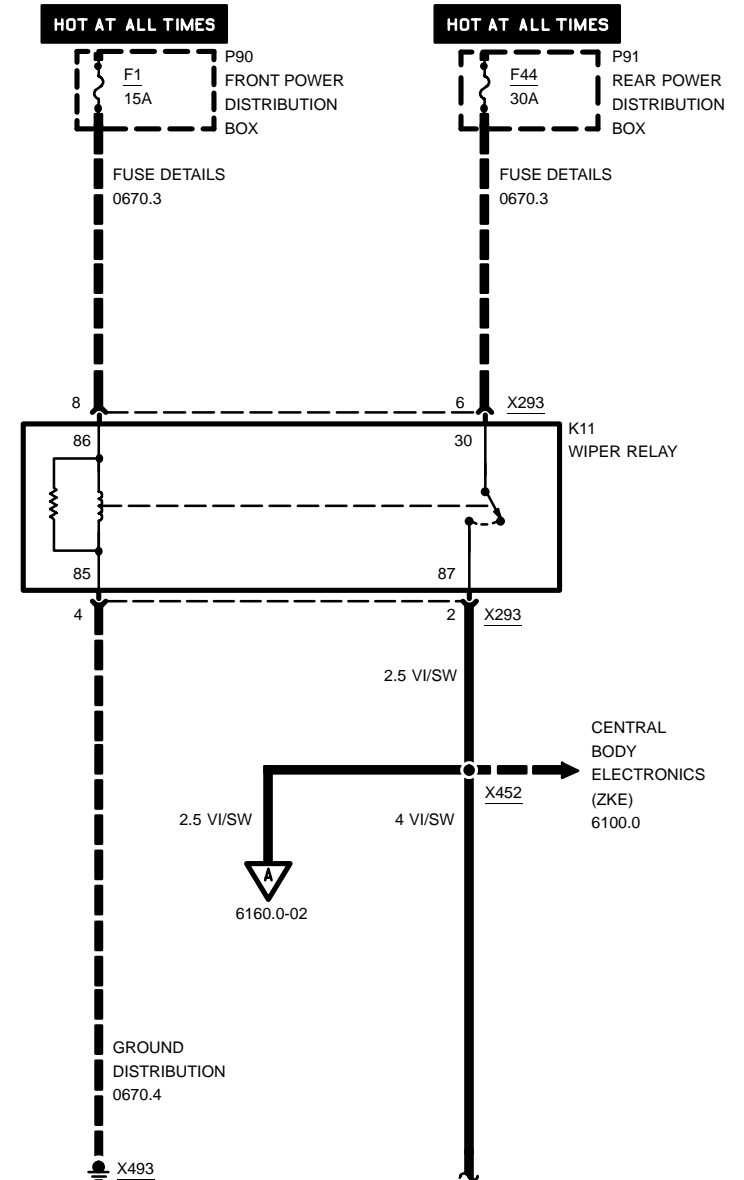



Z3

INTRODUCTION

General Conventions

1. Switches and relays are always shown in rest position (e.g. K11).
2. A component shown in a dashed frame signifies that the component is illustrated only in part (e.g. P90 and P91).
3. A component shown in a completely drawn frame signifies that the component is illustrated in full (e.g. K11).
4. The dashed line between pin 8 and pin 6 of connector X293 indicates that both pins belong to connector X293.
5. The dashed line from fuse F1 to pin 8 of connector X293 shows the positive supply of relay K11. If required, refer to cell **0670.3 Fuse Details** at fuse F1 for the complete line progressing with plug connections, line branches, wire colors and cross sections.
6. The dashed line with an arrow at splice X452 indicates that several wires lead to splice X452. All lines leading to the connection are illustrated in cell **6100.0 Central Body Electronics (ZKE)**. An interrupted line with an arrow indicates that only this one wire leads to another circuit.
7. The dashed line from pin 4 of connector X293 to ground X493 shows the ground supply for relay K11. If required, refer to cell **0670.4 Ground Distribution** at ground X493 for the complete line progression with all plug connections, line branches, wire colors, and cross sections.
8. The interrupted line from splice X452 with an **A** in the open arrow is continued on page 6160.0–02. Termination of wire 4 VI/SW from splice X452 with a wavy line indicates that the wire is continued on the opposite page.

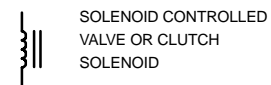
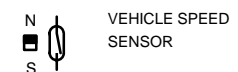
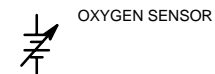
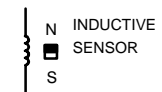
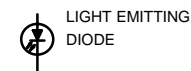
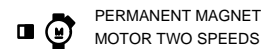
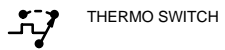
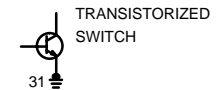
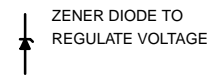
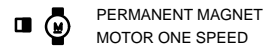
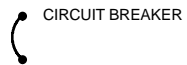
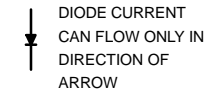
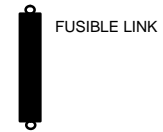
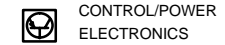
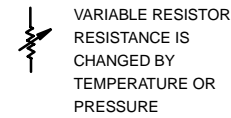
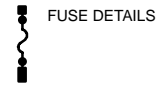
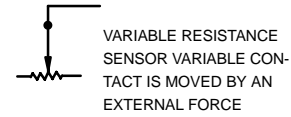
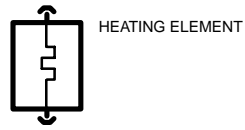
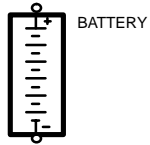

SYMBOLS

Z3



ENTIRE COMPONENT SHOWN

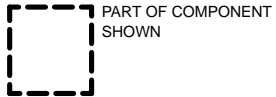

PART OF COMPONENT SHOWN

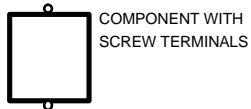

COMPONENT WITH SCREW TERMINALS

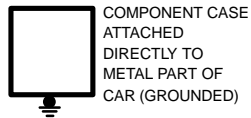

COMPONENT CASE ATTACHED DIRECTLY TO METAL PART OF CAR (GROUNDED)

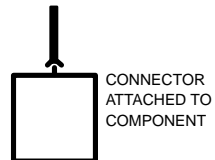

CONNECTOR ATTACHED TO COMPONENT

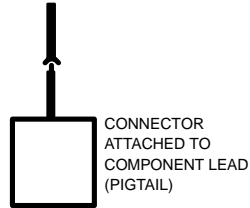

CONNECTOR ATTACHED TO COMPONENT LEAD (PIGTAIL)

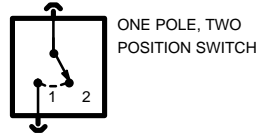

ONE POLE, TWO POSITION SWITCH

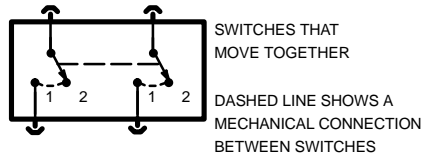

SWITCHES THAT MOVE TOGETHER
DASHED LINE SHOWS A MECHANICAL CONNECTION BETWEEN SWITCHES

WIRE COLOR	
BL	BLUE
BR	BROWN
GE	YELLOW
GN	GREEN
GR	GRAY
OR	ORANGE
RS	PINK
RT	RED
SW	BLACK
VI	VIOLET
WS	WHITE
TR	TRANSPARENT

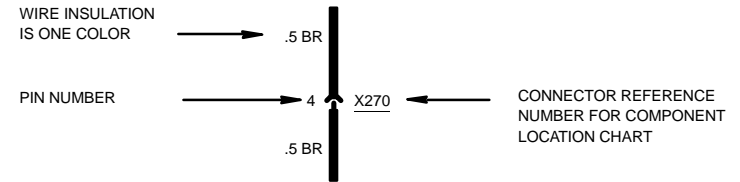

WIRE INSULATION IS ONE COLOR

PIN NUMBER

CONNECTOR REFERENCE NUMBER FOR COMPONENT LOCATION CHART

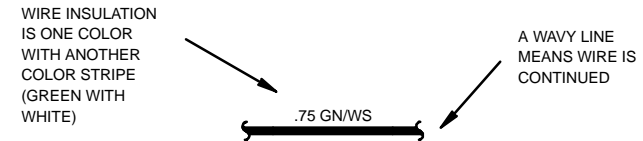

WIRE INSULATION IS ONE COLOR WITH ANOTHER COLOR STRIPE (GREEN WITH WHITE)

A WAVY LINE MEANS WIRE IS CONTINUED

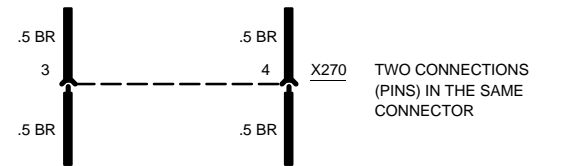

TWO CONNECTIONS (PINS) IN THE SAME CONNECTOR

DASHED LINE INDICATES TERMINALS OF THE SAME CONNECTOR

WIRE SIZE IN MM SQUARED

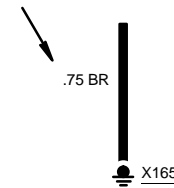

WIRE ATTACHED TO METAL PART OF CAR (GROUNDED)

GROUND NUMBERED FOR REFERENCE ON COMPONENT LOCATION CHART

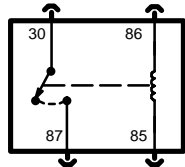

CONTACT RELAY

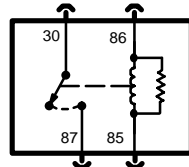

RELAY WITH RESISTOR ACROSS WINDING

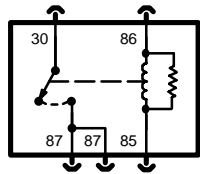

CONTACT RELAY WITH TWO OUTPUTS

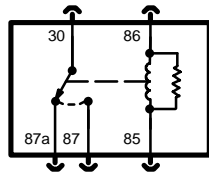

CHANGEOVER RELAY WITH TWO OUTPUTS

TERMINAL NUMBER	DESCRIPTION
30	RELAY INPUT
85	RELAY OUTPUT (WINDING)
86	RELAY INPUT (WINDING)
87	RELAY OUTPUT (ENERGIZED)
87a	RELAY OUTPUT (AT REST)

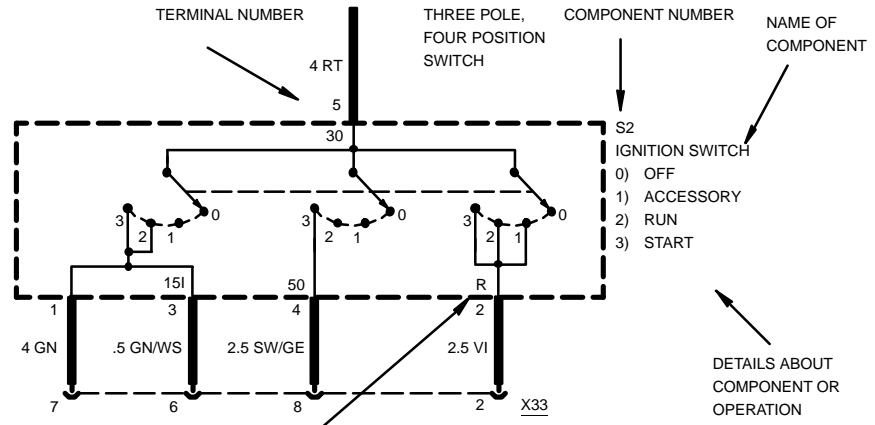

TERMINAL NUMBER	DESCRIPTION	TERMINAL NUMBER	DESCRIPTION
50	VOLTAGE: IGNITION SWITCH IN START	15I	VOLTAGE: IGNITION SWITCH IN RUN
30	VOLTAGE: SUPPLIED AT ALL TIMES	R	VOLTAGE: IGNITION SWITCH IN ACCESSORY, RUN OR START
15	VOLTAGE: IGNITION SWITCH IN RUN OR START	31	GROUND

HOT AT ALL TIMES

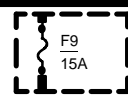

INDICATES THAT FUSE 9 IS SUPPLIED WITH POWER AT ALL TIMES

POWER STATUS	DESCRIPTION
HOT AT ALL TIMES	VOLTAGE: SUPPLIED AT ALL TIMES
HOT IN RUN AND START	VOLTAGE: IGNITION SWITCH IN RUN OR START
HOT IN ACCY, RUN AND START	VOLTAGE: IGNITION SWITCH IN ACCESSORY, RUN OR START



SYMBOLS

Z3

HOT IN ACCY, RUN AND START

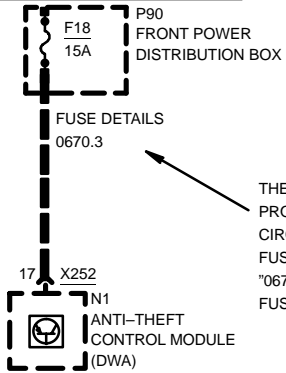

THE COMPLETE WIRE
PROGRESSION AND FURTHER
CIRCUITS CONNECTED TO
FUSE 18 ARE SHOWN IN CELL
"0670.3 FUSE DETAILS" AT
FUSE 18

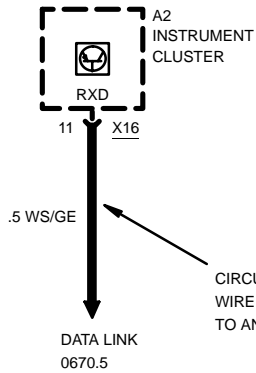

CIRCUIT REFERENCE—A
WIRE WHICH CONNECTS
TO ANOTHER CIRCUIT

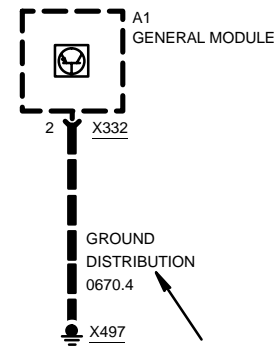

THE COMPLETE WIRE
PROGRESSION AND
FURTHER CIRCUITS
CONNECTED TO
GROUND X497 ARE
SHOWN IN CELL
"0670.4 GROUND
DISTRIBUTION" AT
GROUND X497

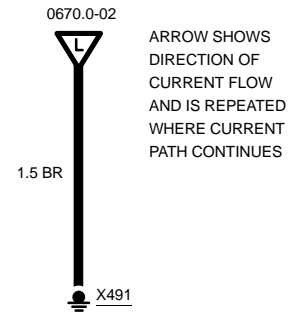
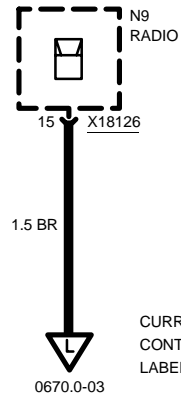



0670.0 POWER DISTRIBUTION CHART

FRONT POWER DISTRIBUTION BOX

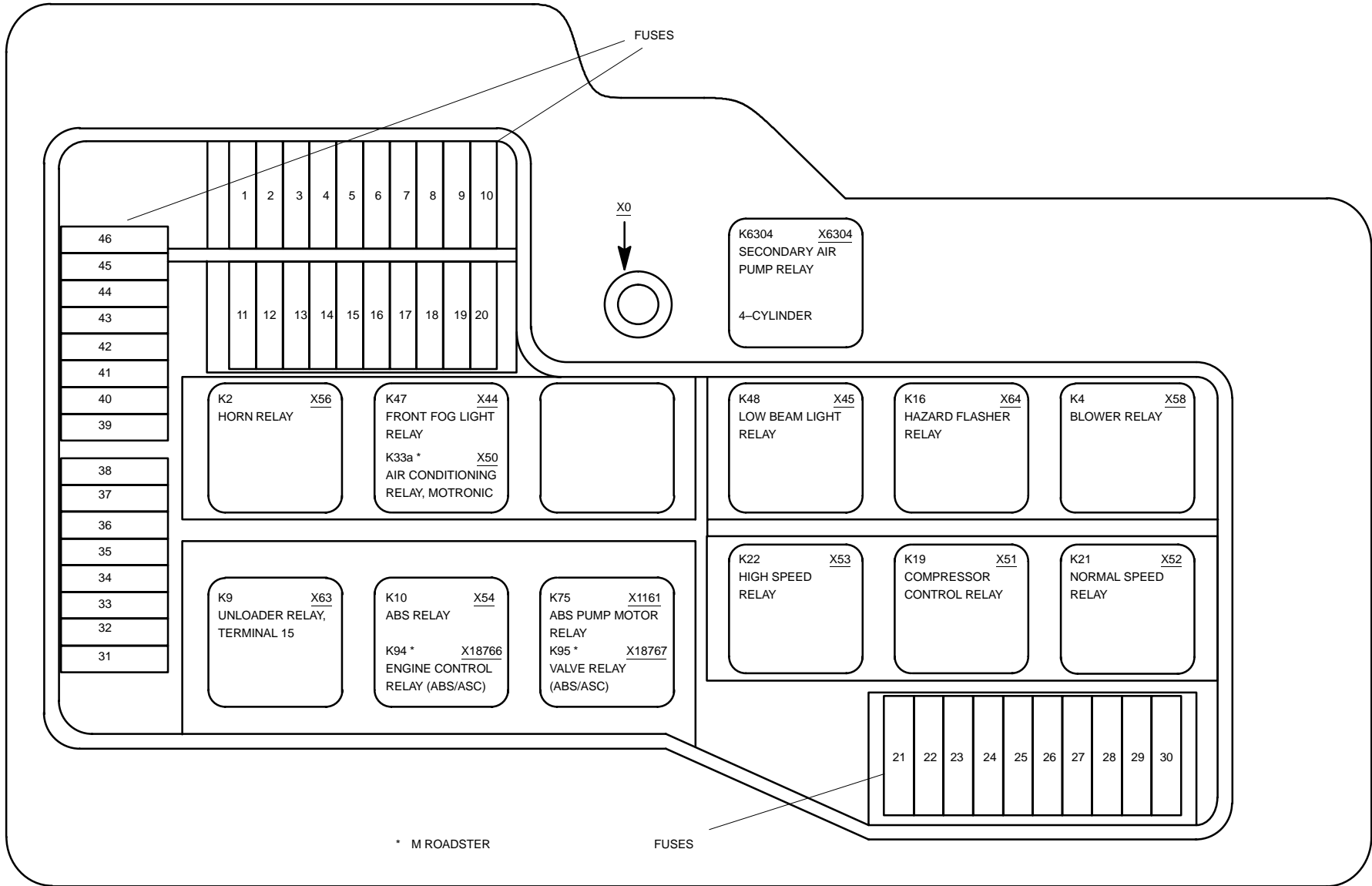

* M ROADSTER

FUSES



POWER DISTRIBUTION CHART

IN E-BOX

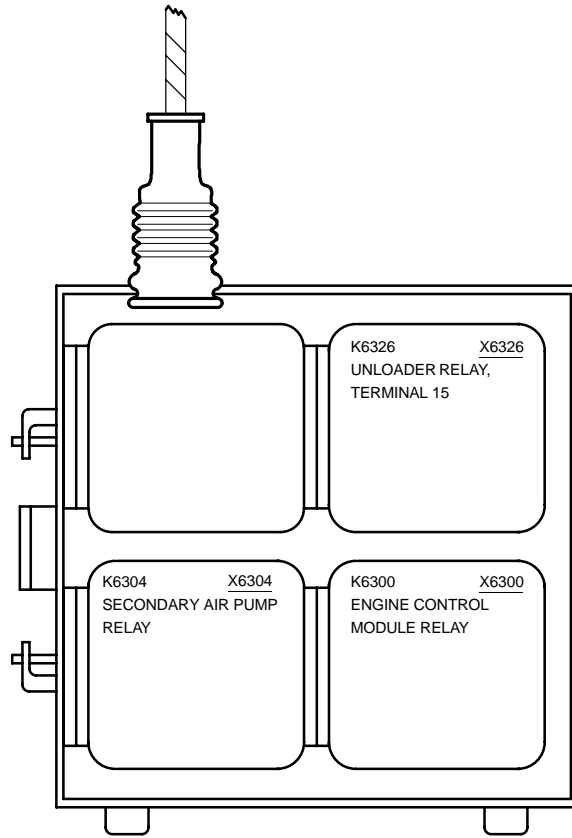

6-CYLINDER

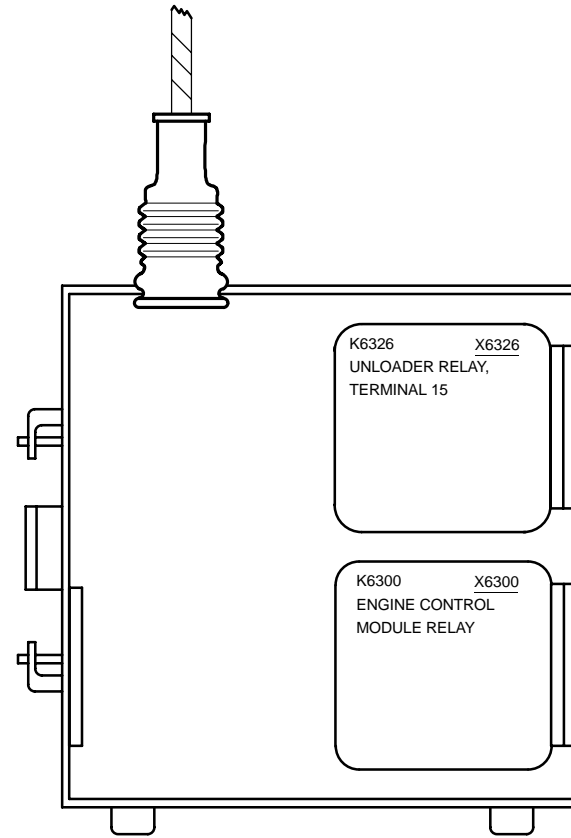

4-CYLINDER



Z3

POWER DISTRIBUTION CHART

RELAY PANEL UNDER LH SIDE OF DASHBOARD

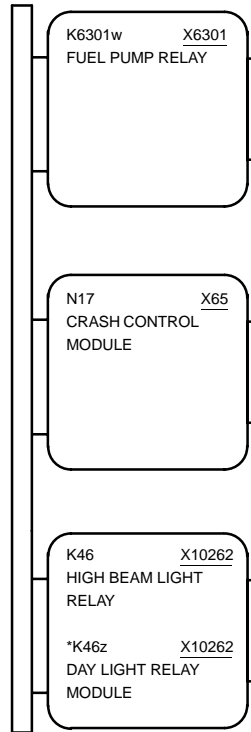



0670.1 FUSE CHART

FUSES 1 TO 29

Z3

	FUSE NUMBER																													
	1	2	3	4	5	6	7	8	9	10	11	12	13	14	15	16	17	18	19	20	21	22	23	24	25	26	27	28	29	
	30A	15A	30A	15A	30A	20A	5A	15A	20A	30A	7.5A	7.5A	5A	30A	15A	5A		15A	30A	30A	5A	5A	5A	10A	5A	10A	5A	5A	7.5A	
1210.17 ENGINE CONTROL SYSTEM MS41.1 (6-CYLINDER M52/S52)													●			●		●												
1210.20 ENGINE CONTROL SYSTEM (DME M5.2, 4-CYLINDER M44)													●			●		●												
1230.0 CHARGING SYSTEM																											●			
1240.0 START																													●	
1290.0 E-BOX FAN																														
2460.2 ELECTRONIC TRANSMISSION CONTROL (EGS A4S 270R)																											●		●	
3234.0 SUPPLEMENTAL RESTRAINT SYSTEM (AIR BAG)																									●			●		
3450.0 SLIP CONTROL (ABS)											●										●							●		
3450.1 SLIP CONTROL (ABS/ASC)											●		●								●									
5116.0 POWER MIRRORS																									●			●		
5126.0 ZKE CENTRAL LOCKING (ZV)							●																							
5133.0 ZKE POWER WINDOWS (FH)															●															
5200.0 POWER SEATS					●															●										
5203.0 HEATED SEATS			●																				●							
5430.2 ELECTRO-HYDRAULIC CONVERTIBLE TOP	●																													
6100.0 CENTRAL BODY ELECTRONICS (ZKE IV)																		●												
6133.0 HORN								●																						
6135.0 DRIVE-AWAY PROTECTION (EWS II)																													●	
6160.1 WIPER/WASHER MODULE (WWM)			●																											
6167.1 HEADLIGHT WASHER (SRA)			●																											
6169.0 WINDSHIELD WASHER JET HEATERS																									●					



FUSE CHART

FUSES 1 TO 29

Z3

	FUSE NUMBER																												
	1	2	3	4	5	6	7	8	9	10	11	12	13	14	15	16	17	18	19	20	21	22	23	24	25	26	27	28	29
	30A	15A	30A	15A	30A	20A	5A	15A	20A	30A	7.5A	7.5A	5A	30A	15A	5A		15A	30A	30A	5A	5A	5A	10A	5A	10A	5A	5A	7.5A
6211.0 INSTRUMENT CLUSTER						●																●				●			
6213.3 DIGITAL CLOCK																													
6300.0 LIGHT SWITCH DETAILS																						●	●		●				
6312.0 HEADLIGHTS/FOG LIGHTS											●	●			●							●	●		●				●
6313.0 TURN/HAZARD LIGHTS																							●						
6314.0 PARK/TAIL/UNDERHOOD LIGHTS																													
6320.0 LICENSE PLATE/LUGGAGE COMPARTMENT LIGHTS																													
6322.0 BACK UP LIGHTS																											●		
6325.0 BRAKE LIGHTS																													
6330.3 INTERIOR LIGHTS																													
6332.0 INTERIOR ACCESSORIES																													
6350.0 CRASH CONTROL MODULE											●	●														●			
6424.0 REAR WINDOW DEFOGGER						●																	●						
6450.6 INTEGRATED HEATING- AND CLIMATE CONTROL																●					●								
6510.1 RADIO/HIFI									●																				
6561.0 CELLULAR TELEPHONE (PROVISIONS)																													
6571.0 CRUISE CONTROL (TEMPOMAT)																													
6575.2 ANTI-THEFT SYSTEM (ALPINE)																													●
6581.3 BOARD COMPUTER (BC - LOW)																													

04/99

0670.1-01

1998



FUSE CHART

FUSES 30 TO 49

Z3

		FUSE NUMBER																				
		30	31	32	33	34	35	36	37	38	39	40	41	42	43	44	45	46	47	48	49	
		7.5A	5A	30A	10A	15A	25A	30A	10A	30A	7.5A	30A	15A	5A	5A	15A	7.5A	15A		40A	50A	
1210.17	ENGINE CONTROL SYSTEM MS41.1 (6-CYLINDER M52/S52)										●											
1210.20	ENGINE CONTROL SYSTEM (DME M5.2, 4-CYLINDER M44)																					
1230.0	CHARGING SYSTEM																					
1240.0	START		●														●					
1290.0	E-BOX FAN																					
2460.2	ELECTRONIC TRANSMISSION CONTROL (EGS A4S 270R)																	●				
3234.0	SUPPLEMENTAL RESTRAINT SYSTEM (AIR BAG)											●	●									
3450.0	SLIP CONTROL (ABS)								●								●					
3450.1	SLIP CONTROL (ABS/ASC)								●								●		●			
5116.0	POWER MIRRORS																					
5126.0	ZKE CENTRAL LOCKING (ZV)					●									●							
5133.0	ZKE POWER WINDOWS (FH)																					
5200.0	POWER SEATS																					
5203.0	HEATED SEATS																					
5430.2	ELECTRO-HYDRAULIC CONVERTIBLE TOP																	●				
6100.0	CENTRAL BODY ELECTRONICS (ZKE IV)				●		●								●							
6133.0	HORN																					
6135.0	DRIVE-AWAY PROTECTION (EWS II)		●														●					
6160.1	WIPER/WASHER MODULE (WWM)							●	●							●						
6167.1	HEADLIGHT WASHER (SRA)																●					
6169.0	WINDSHIELD WASHER JET HEATERS																					



FUSE CHART

FUSES 30 TO 49

Z3

		FUSE NUMBER																			
		30	31	32	33	34	35	36	37	38	39	40	41	42	43	44	45	46	47	48	49
		7.5A	5A	30A	10A	15A	25A	30A	10A	30A	7.5A	30A	15A	5A	5A	15A	7.5A	15A		40A	50A
6211.0	INSTRUMENT CLUSTER		●															●			
6213.3	DIGITAL CLOCK		●														●				
6300.0	LIGHT SWITCH DETAILS				●			●													
6312.0	HEADLIGHTS/FOG LIGHTS	●																			
6313.0	TURN/HAZARD LIGHTS				●																
6314.0	PARK/TAIL/UNDERHOOD LIGHTS				●			●													
6320.0	LICENSE PLATE/LUGGAGE COMPARTMENT LIGHTS				●			●													
6322.0	BACK UP LIGHTS																				
6325.0	BRAKE LIGHTS																	●			
6330.3	INTERIOR LIGHTS				●										●						
6332.0	INTERIOR ACCESSORIES			●				●													
6350.0	CRASH CONTROL MODULE				●																
6424.0	REAR WINDOW DEFOGGER																				
6450.6	INTEGRATED HEATING- AND CLIMATE CONTROL									●	●									●	
6510.1	RADIO/HIFI																●				
6561.0	CELLULAR TELEPHONE (PROVISIONS)				●											●					
6571.0	CRUISE CONTROL (TEMPOMAT)																	●			
6575.2	ANTI-THEFT SYSTEM (ALPINE)		●												●						
6581.3	BOARD COMPUTER (BC - LOW)		●															●			

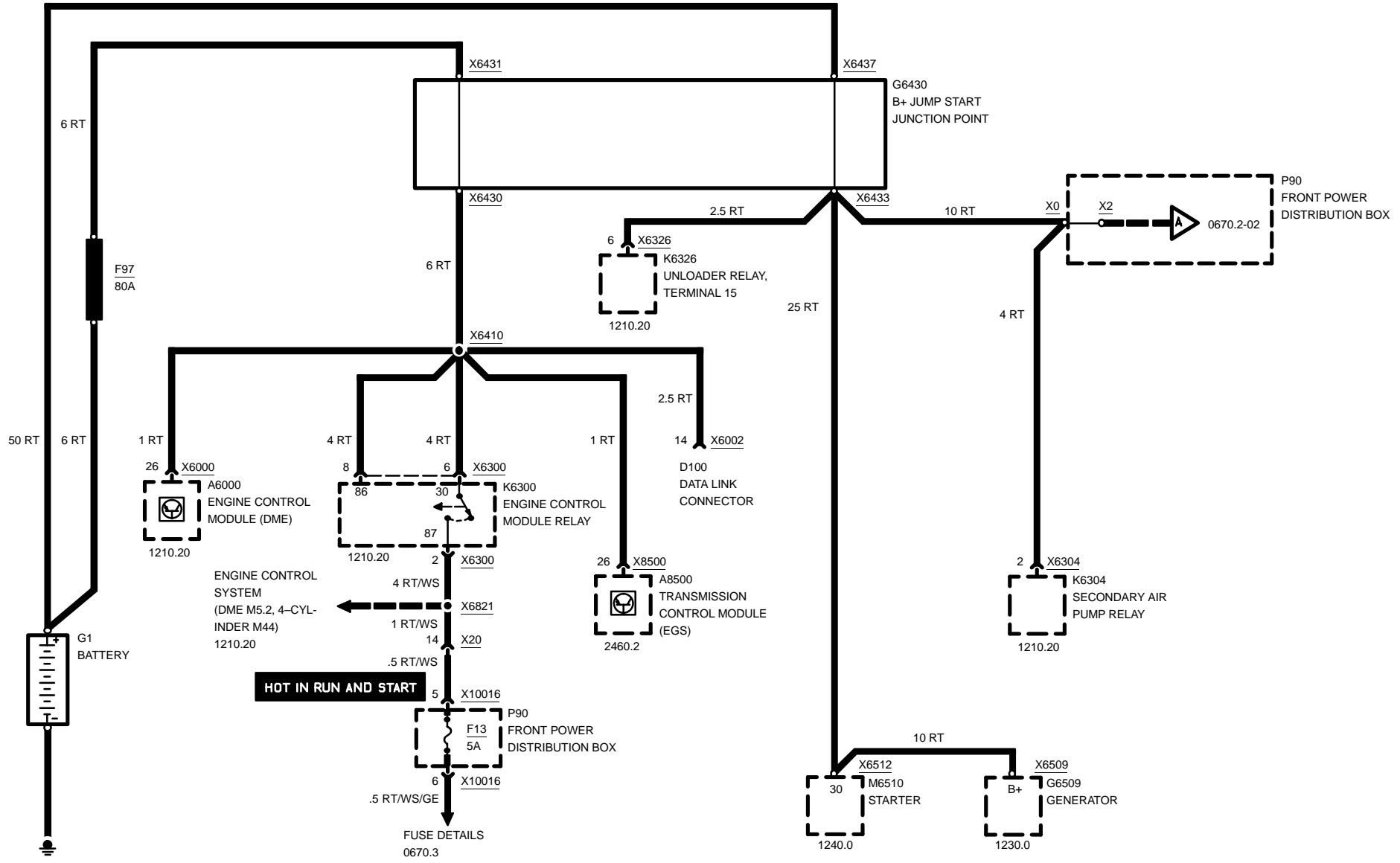



POWER DISTRIBUTION

6-CYLINDER

Z3

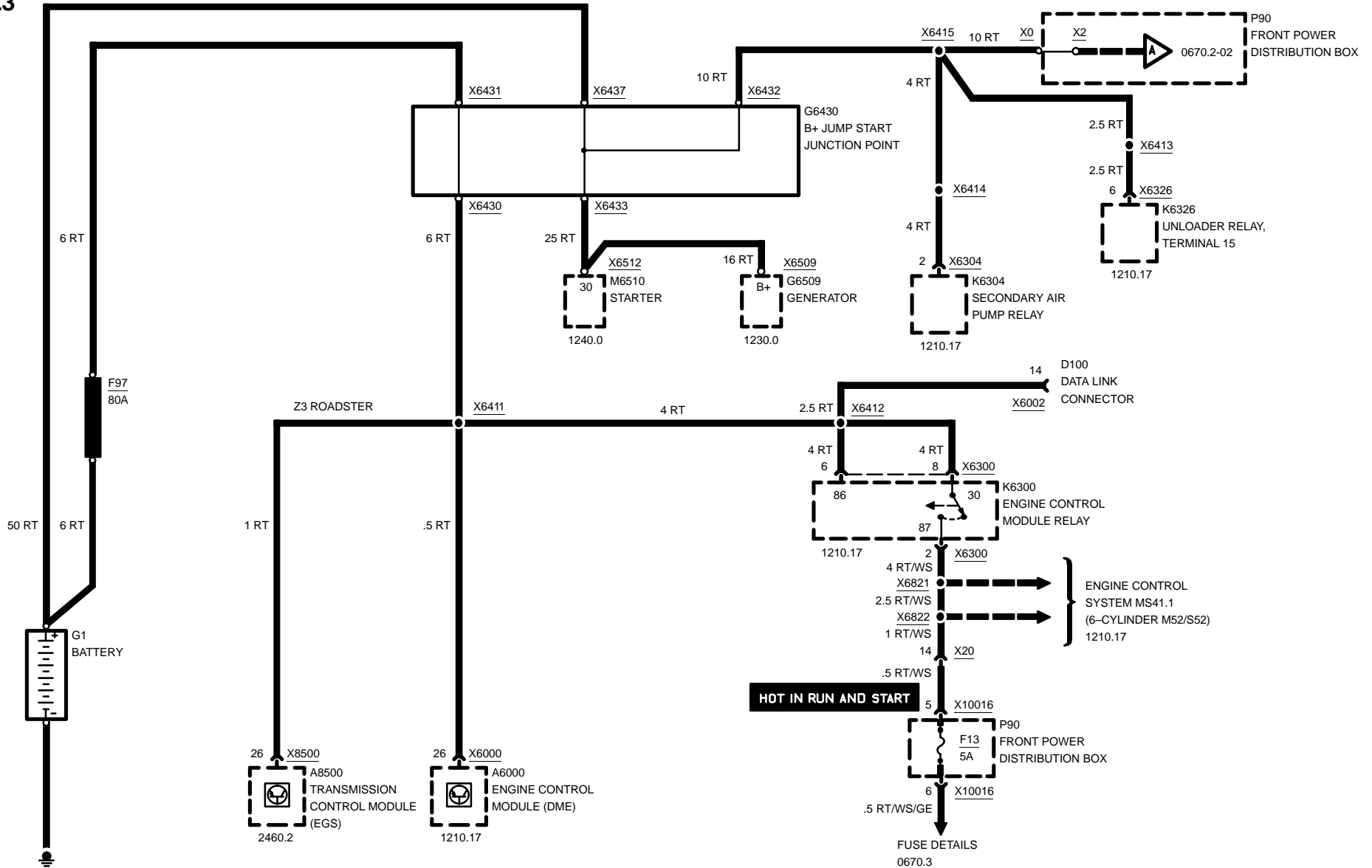

04/99

0670.2-01

1998



POWER DISTRIBUTION

Z3

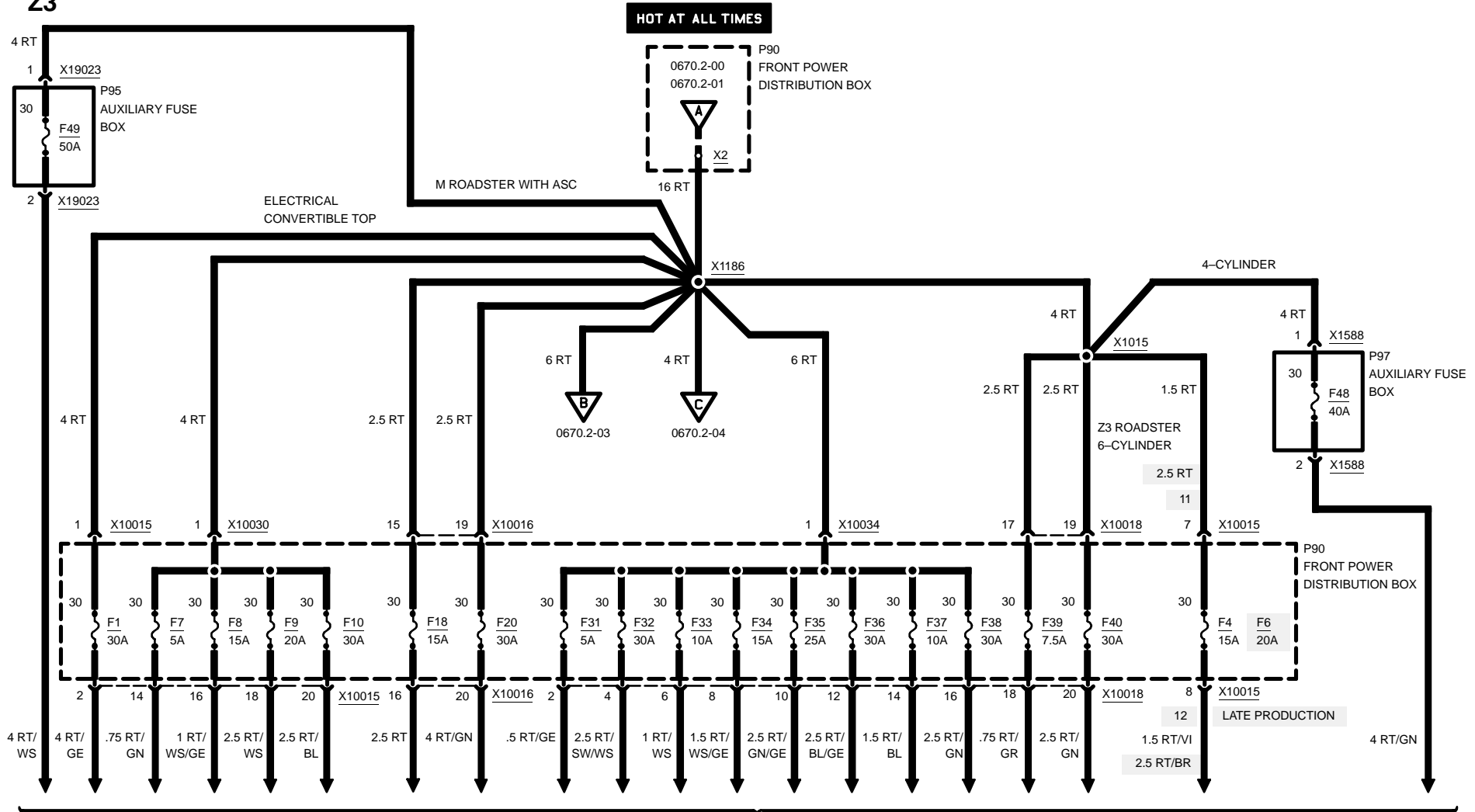

FUSE DETAILS
0670.3

POWER DISTRIBUTION

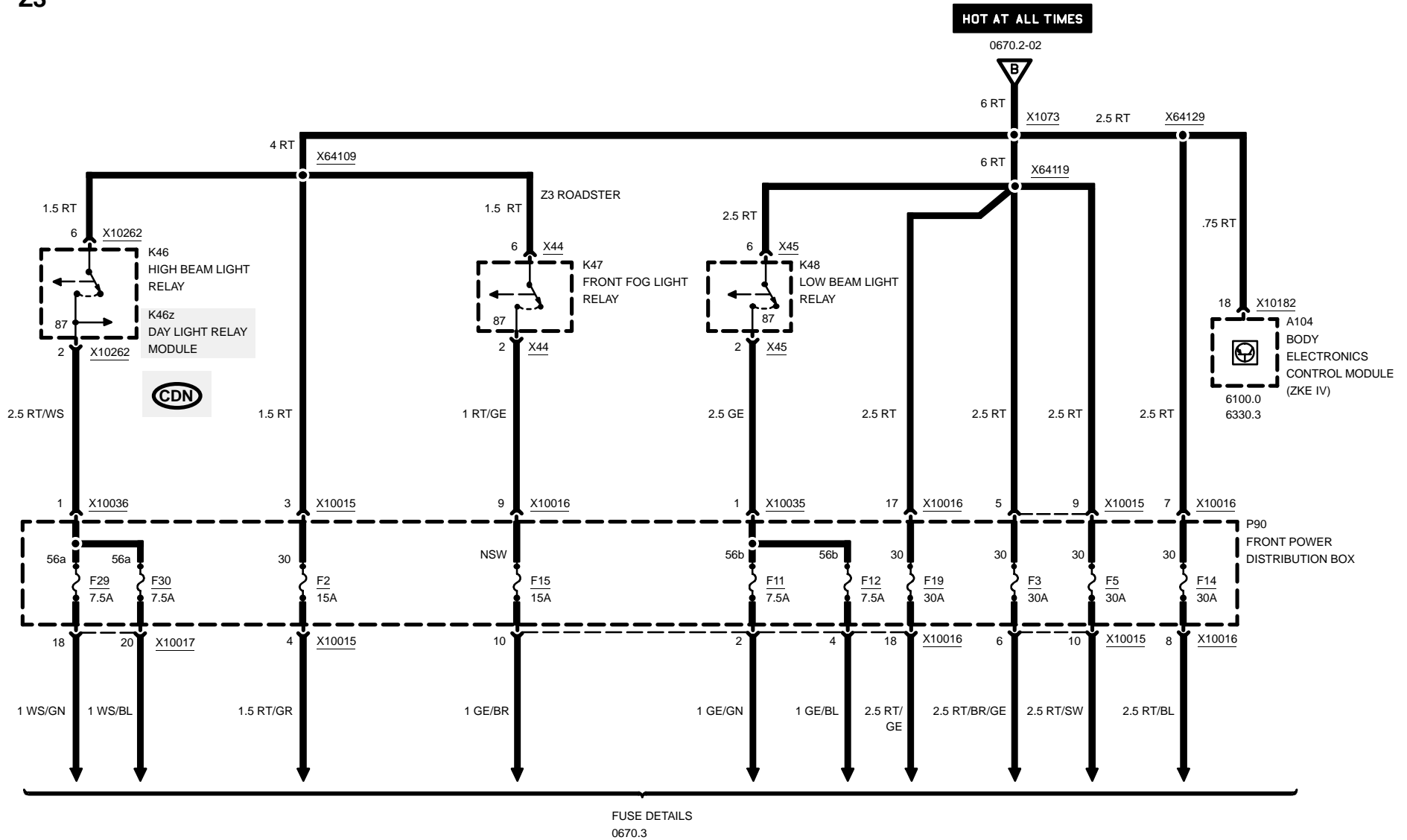

POWER DISTRIBUTION

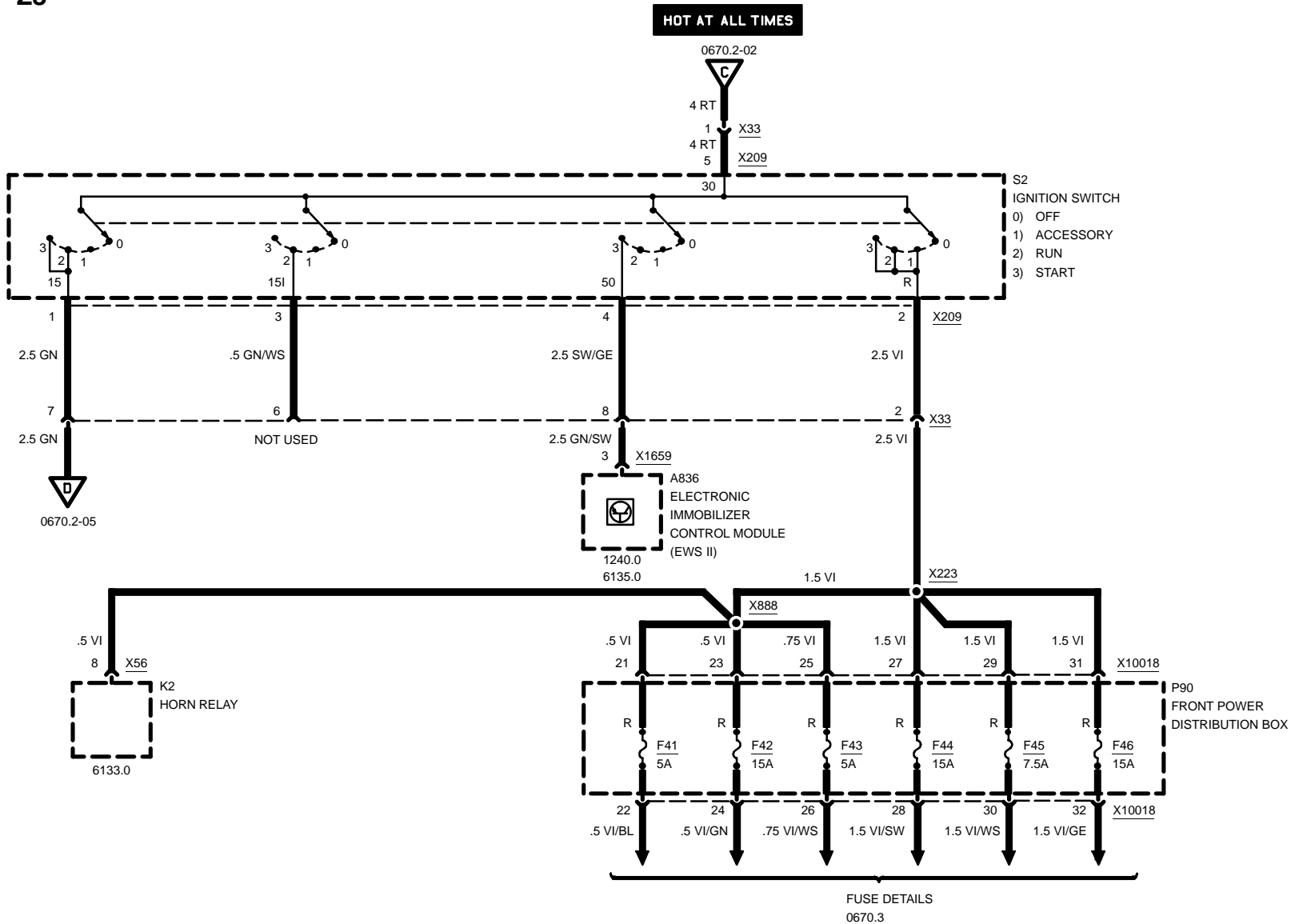

POWER DISTRIBUTION

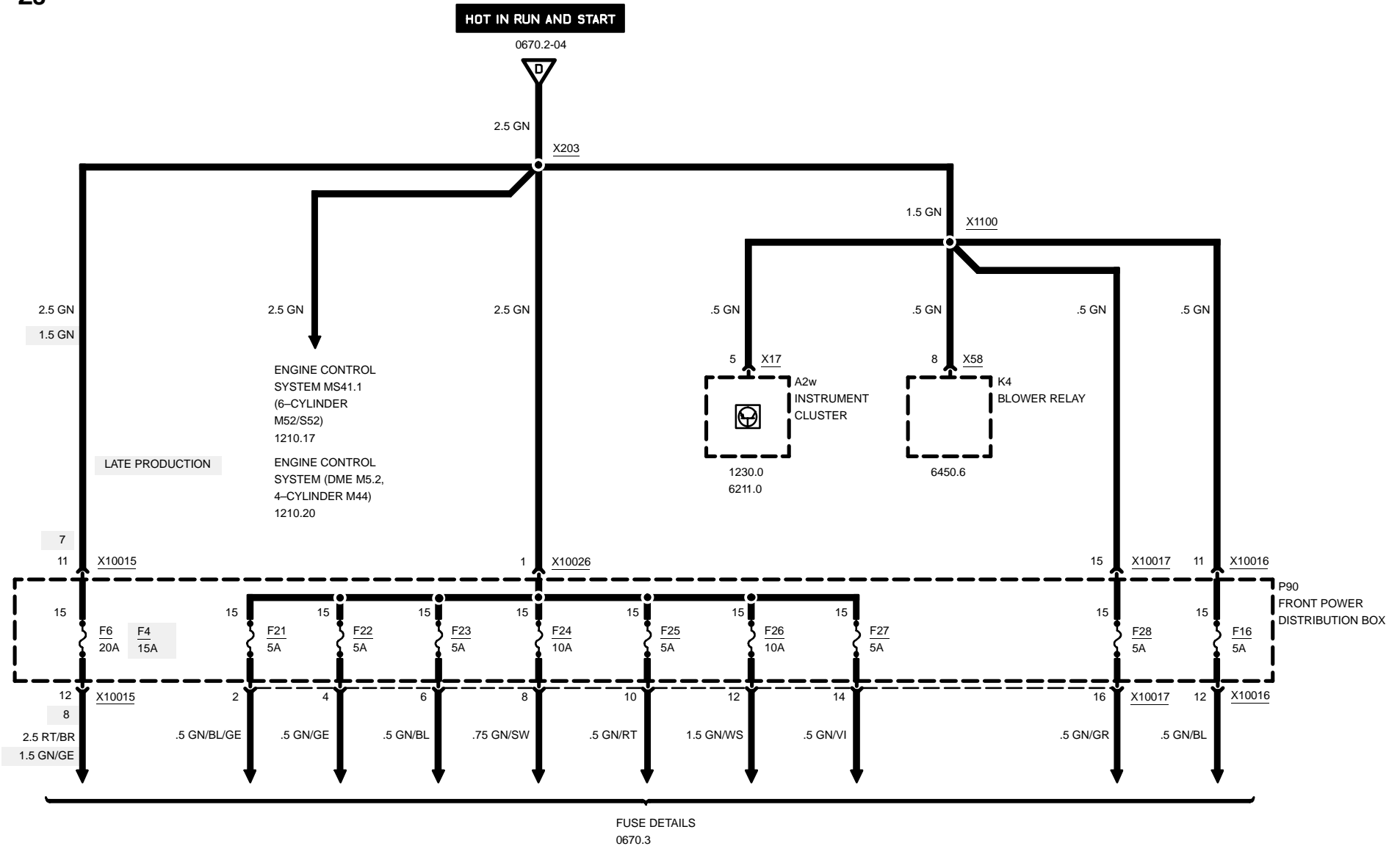



0670.3 FUSE DETAILS

FUSES 1, 2, 3, 4, 5, AND 6

Z3

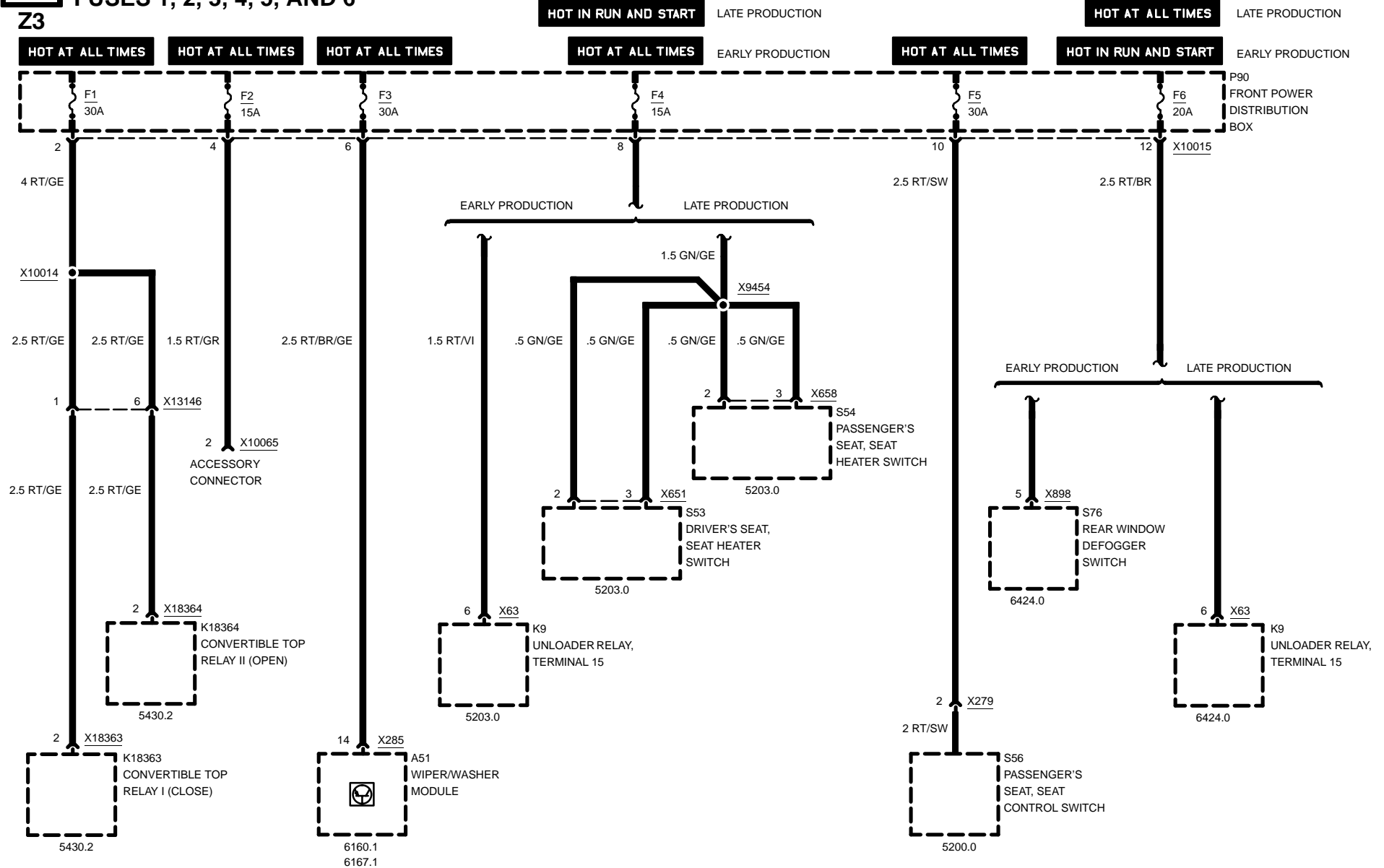

04/99

0670.3-00

1998



FUSE DETAILS

FUSES 7, 8, AND 9

Z3

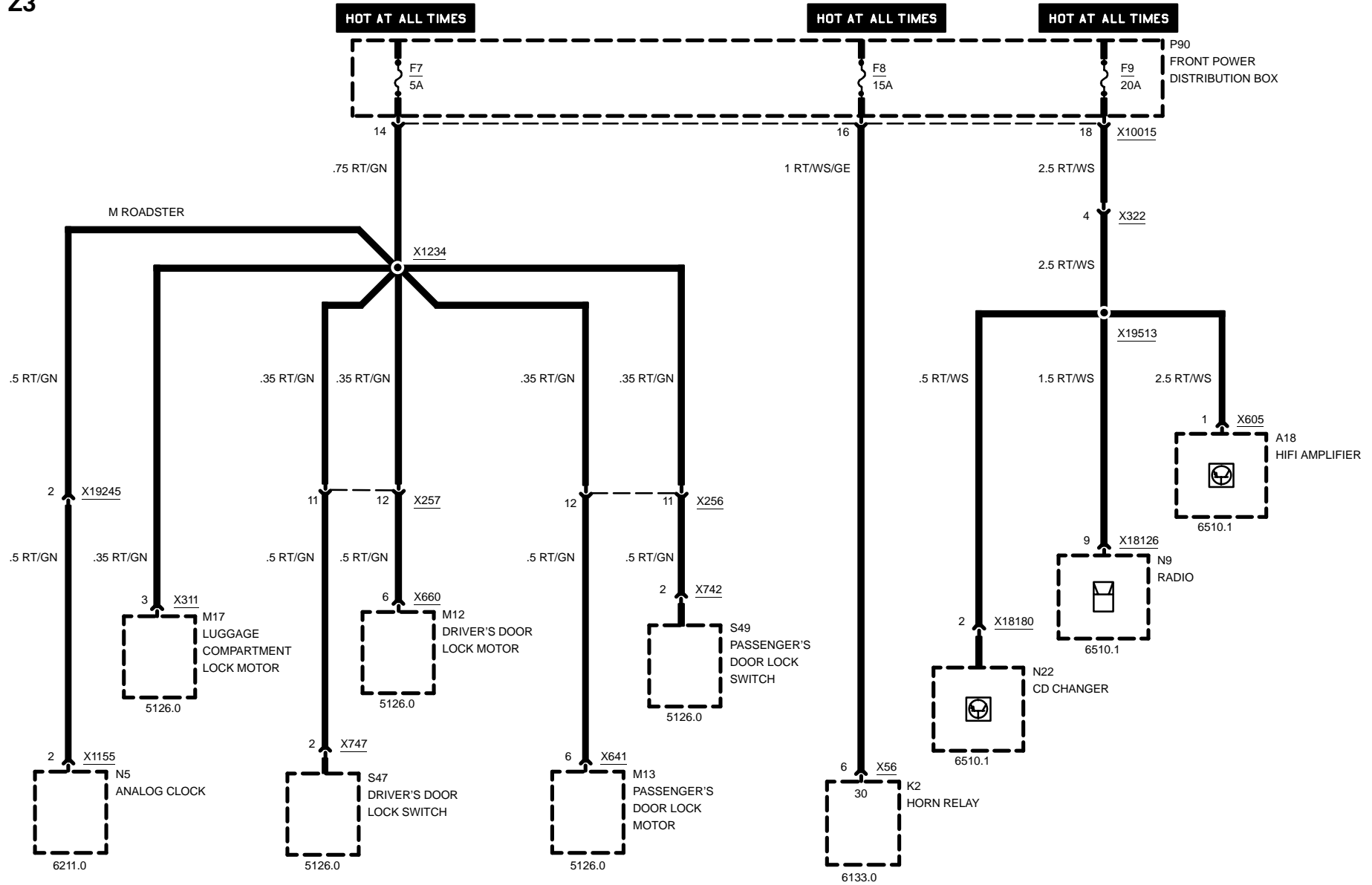



FUSE DETAILS

FUSES 10, 11, AND 12

Z3

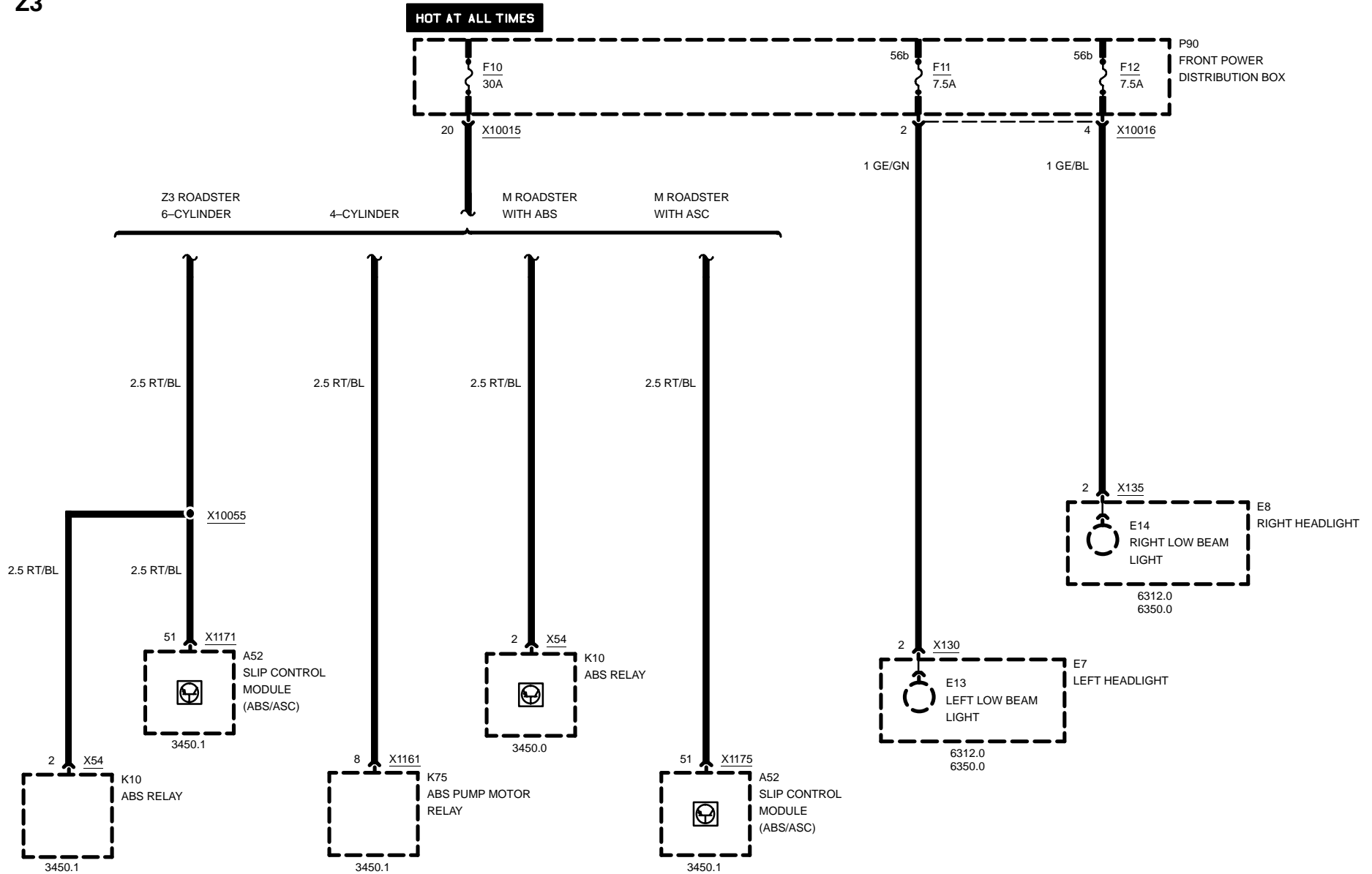

04/99

0670.3-02

1998



FUSE DETAILS

FUSES 13, 14, AND 15

Z3

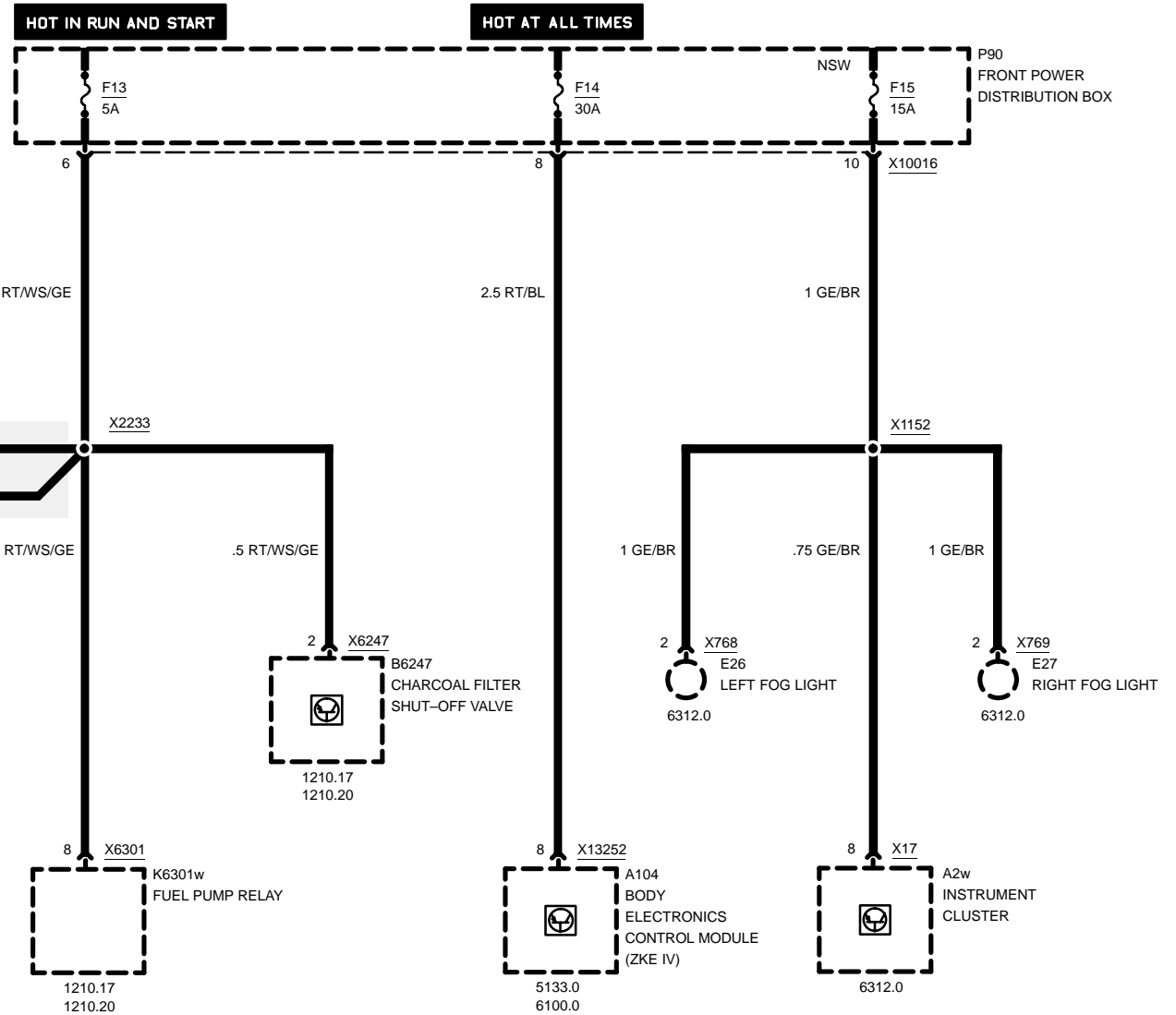

M ROADSTER WITH ASC

04/99

0670.3-03

1998



FUSE DETAILS

FUSES 16, 18, 19, AND 20

Z3

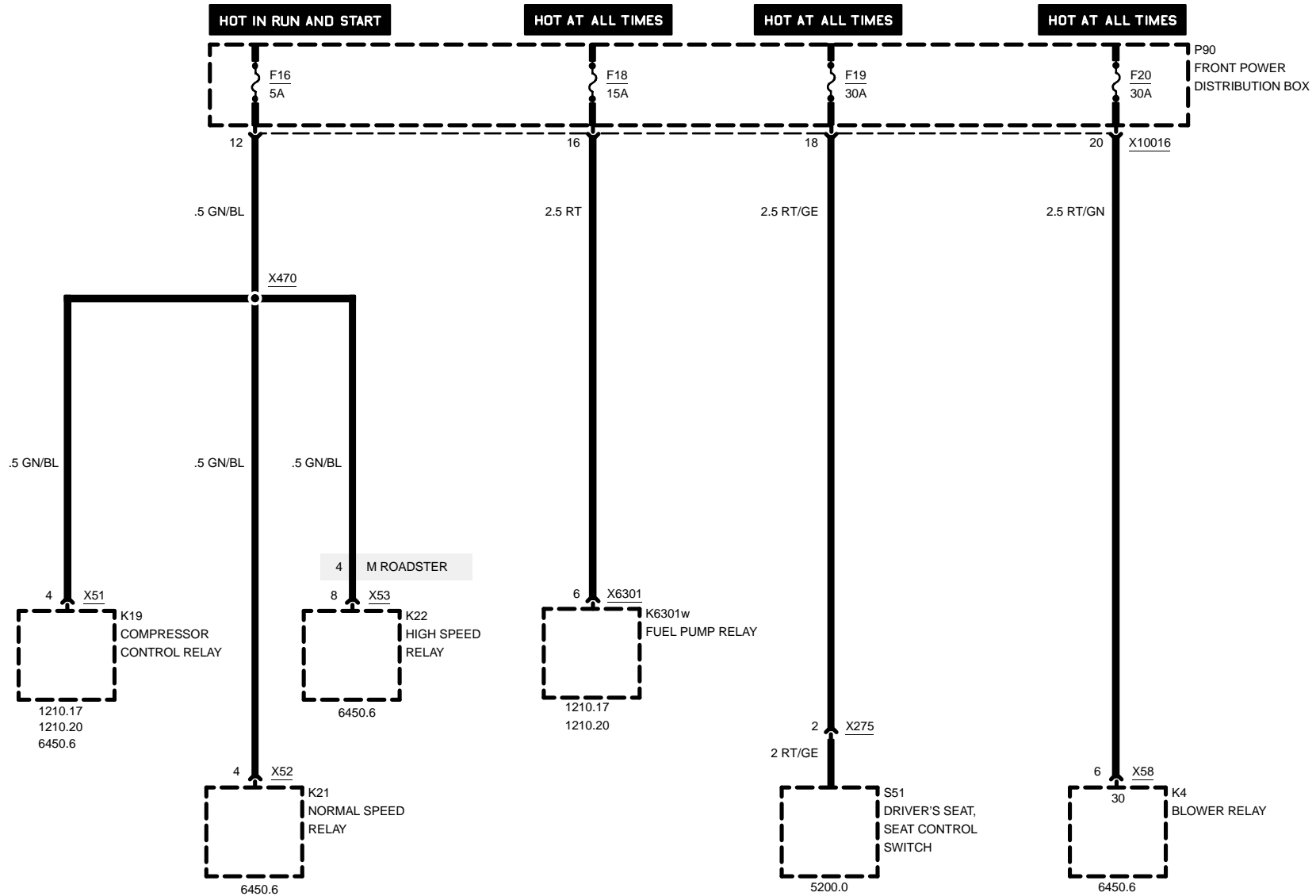



FUSE DETAILS

FUSES 21 AND 22

Z3

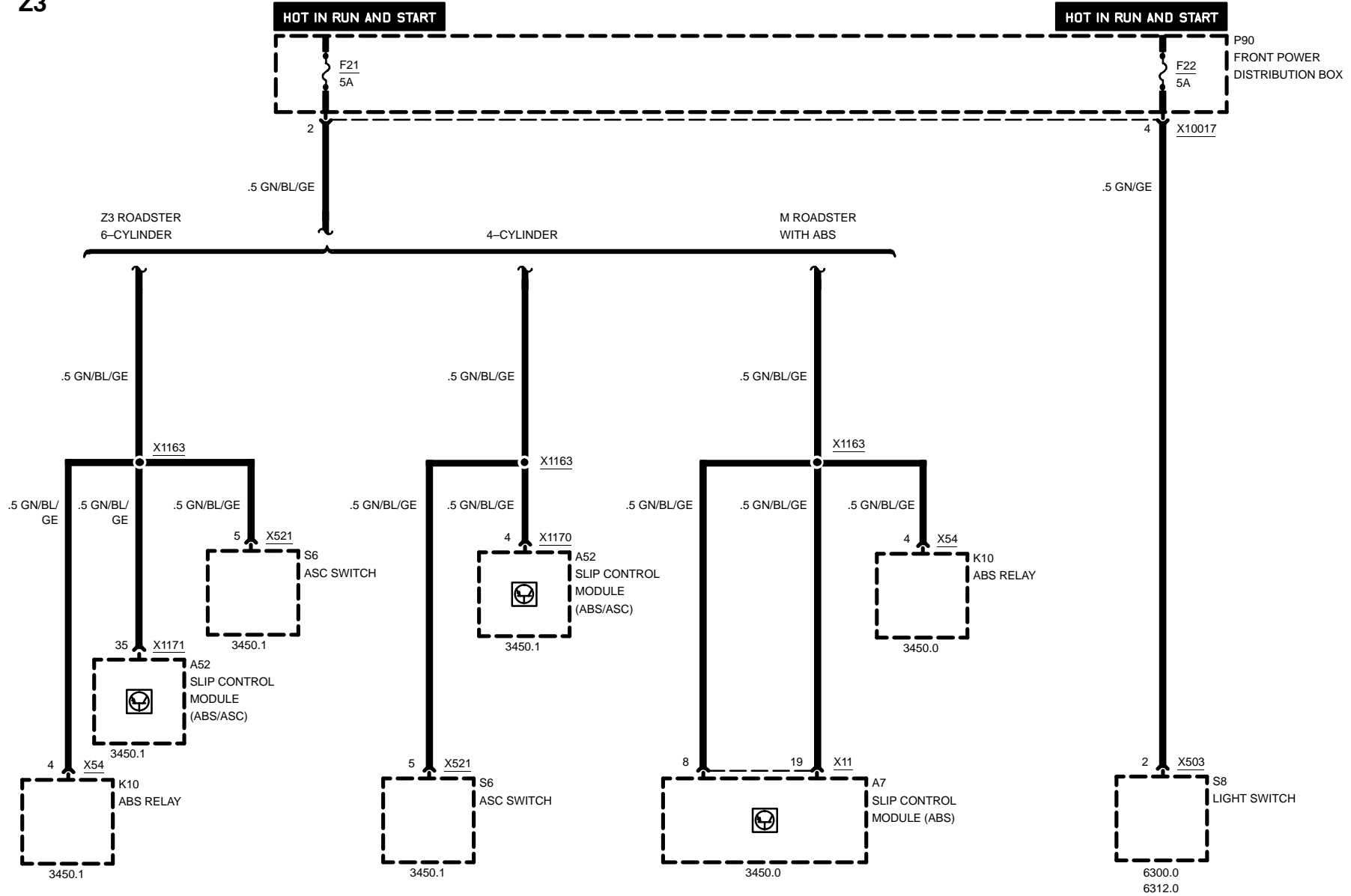



FUSE DETAILS

FUSES 23, 24, AND 25

Z3

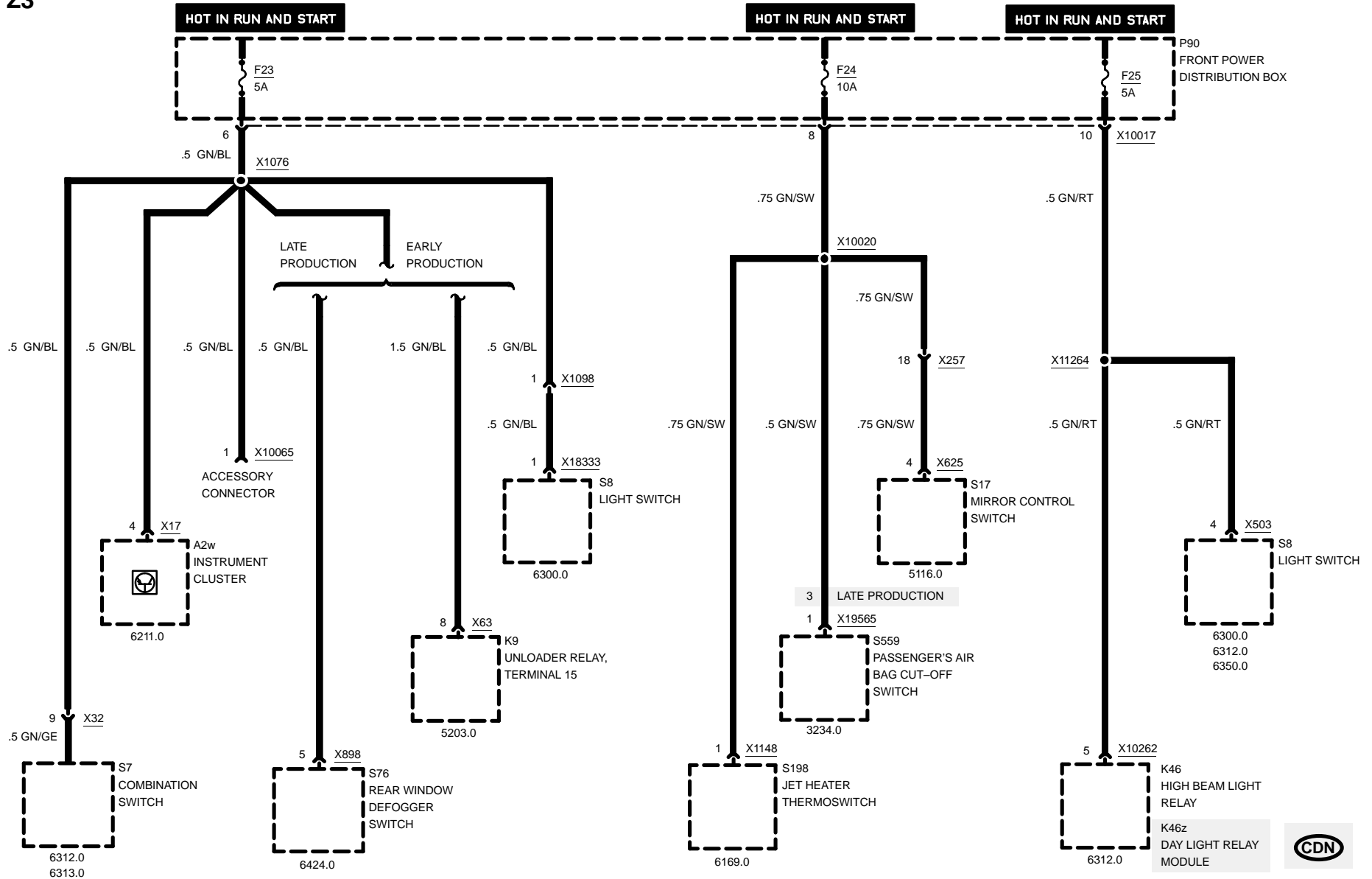

04/99

0670.3-06

1998



FUSE DETAILS

FUSES 26, 27, 28, 29, AND 30

Z3

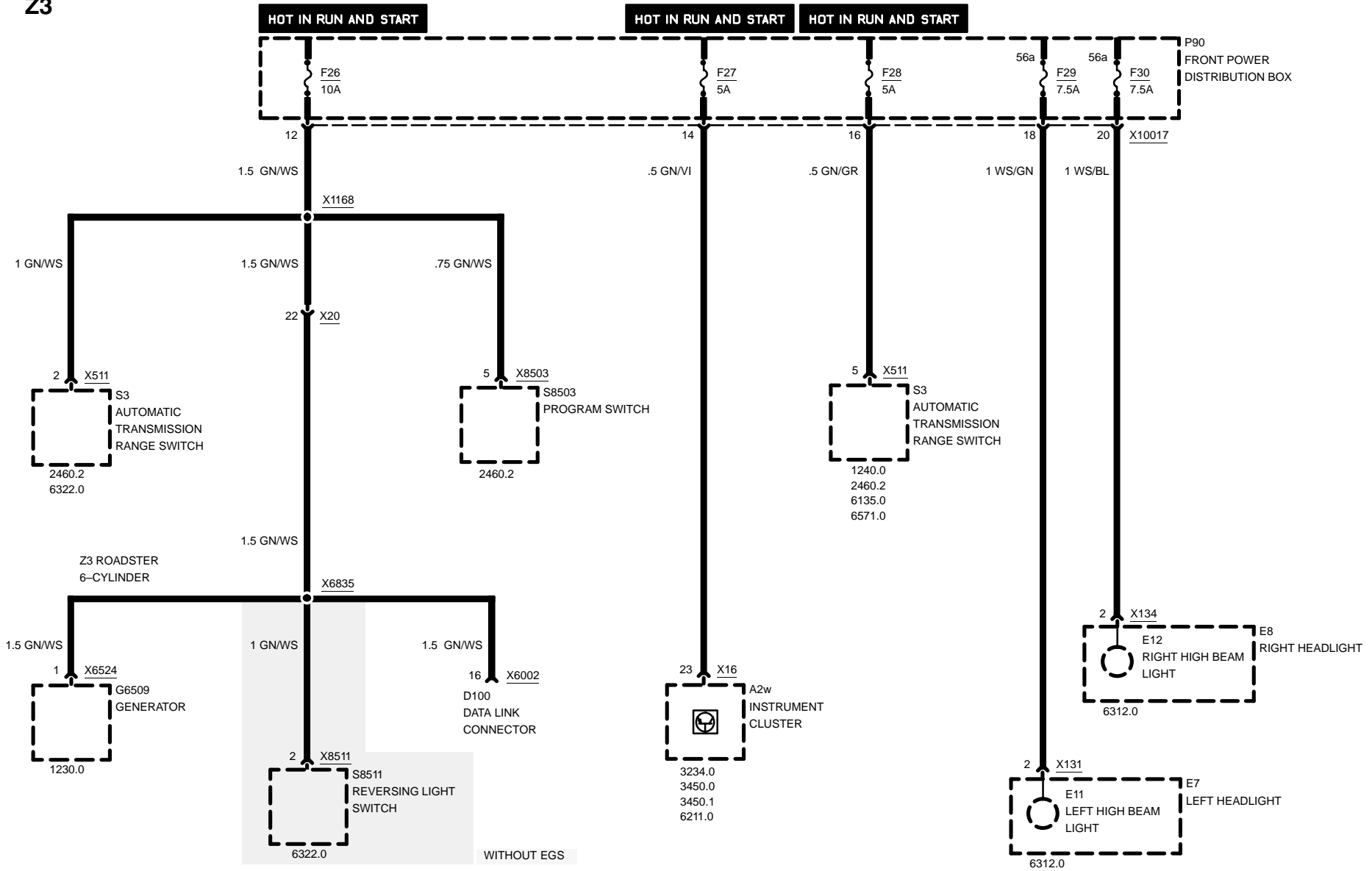



FUSE DETAILS

FUSE 31

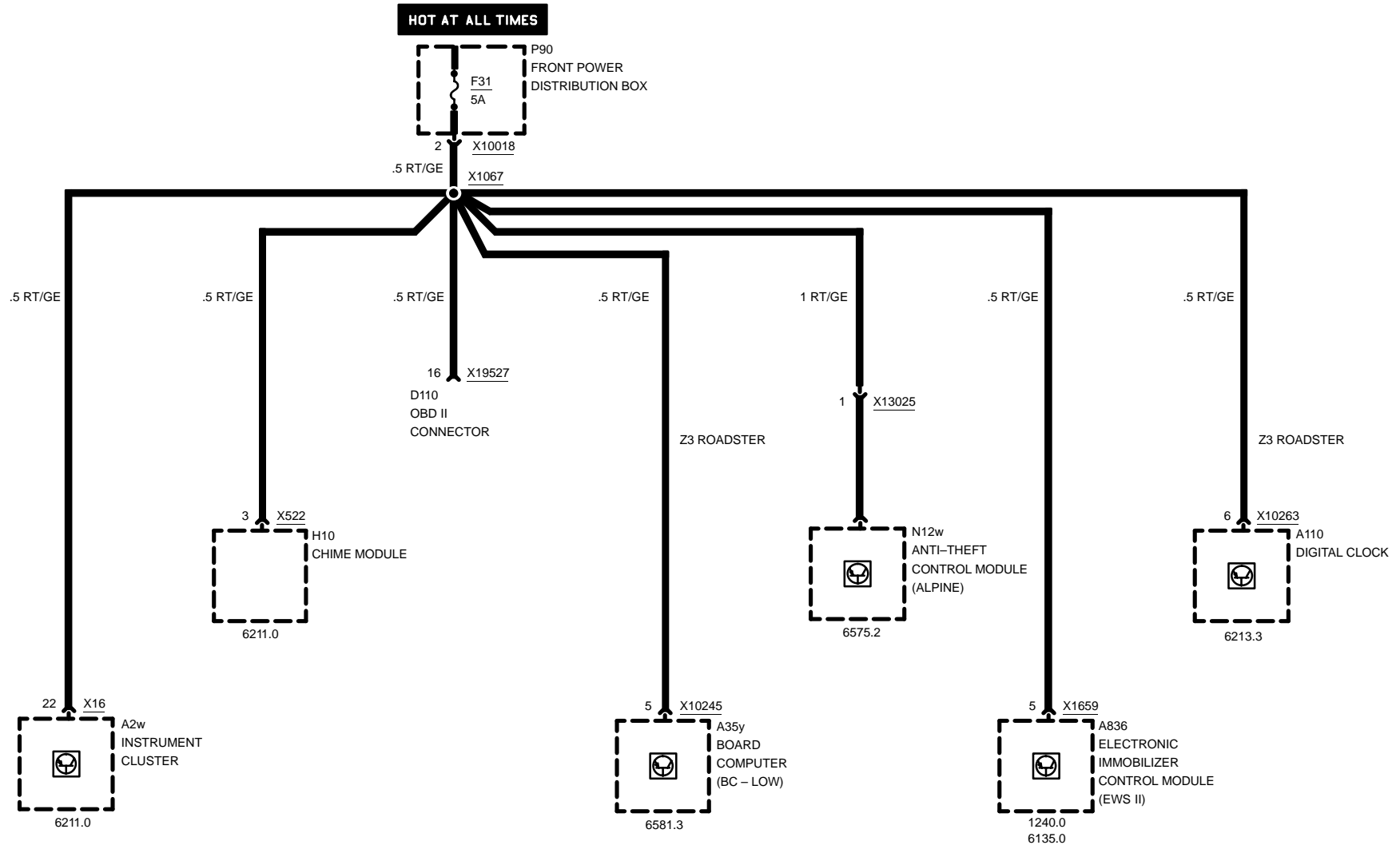



FUSE DETAILS

FUSES 32, 33, 34, AND 35

Z3

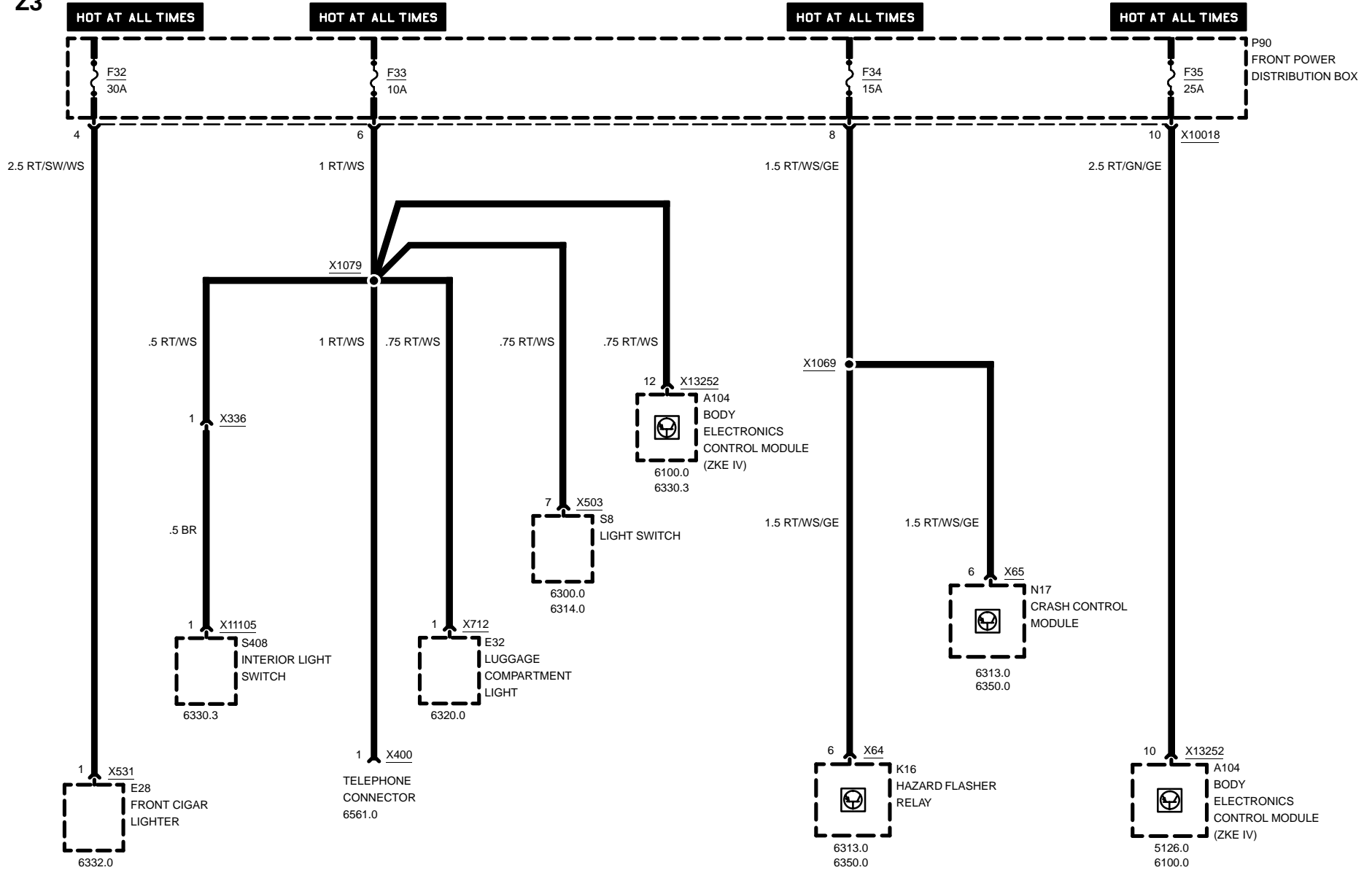

04/99

0670.3-09

1998



FUSE DETAILS

FUSES 36, 37, 38, AND 39

Z3

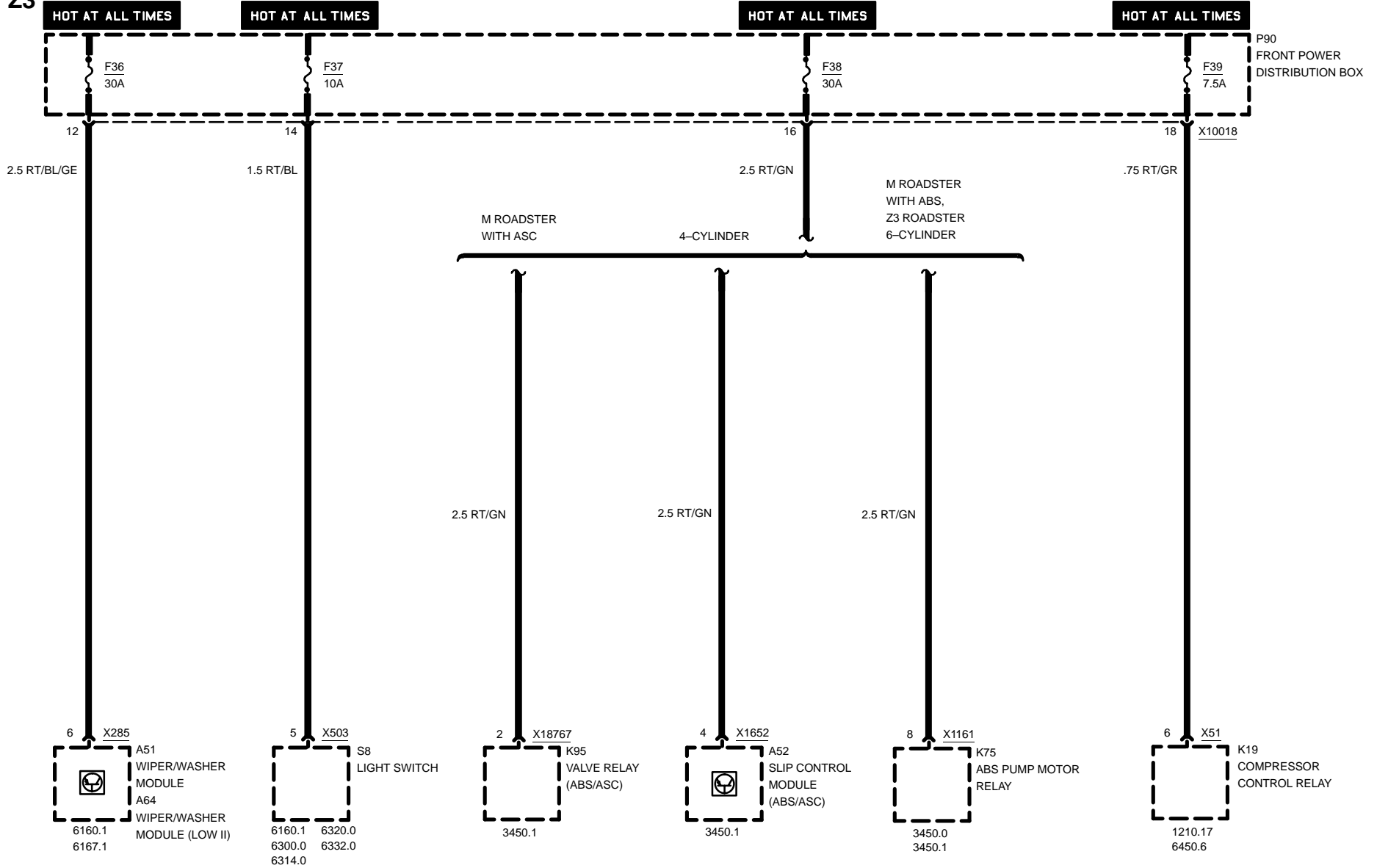

04/99

0670.3-10

1998



FUSE DETAILS

FUSES 40, 41, AND 42

Z3

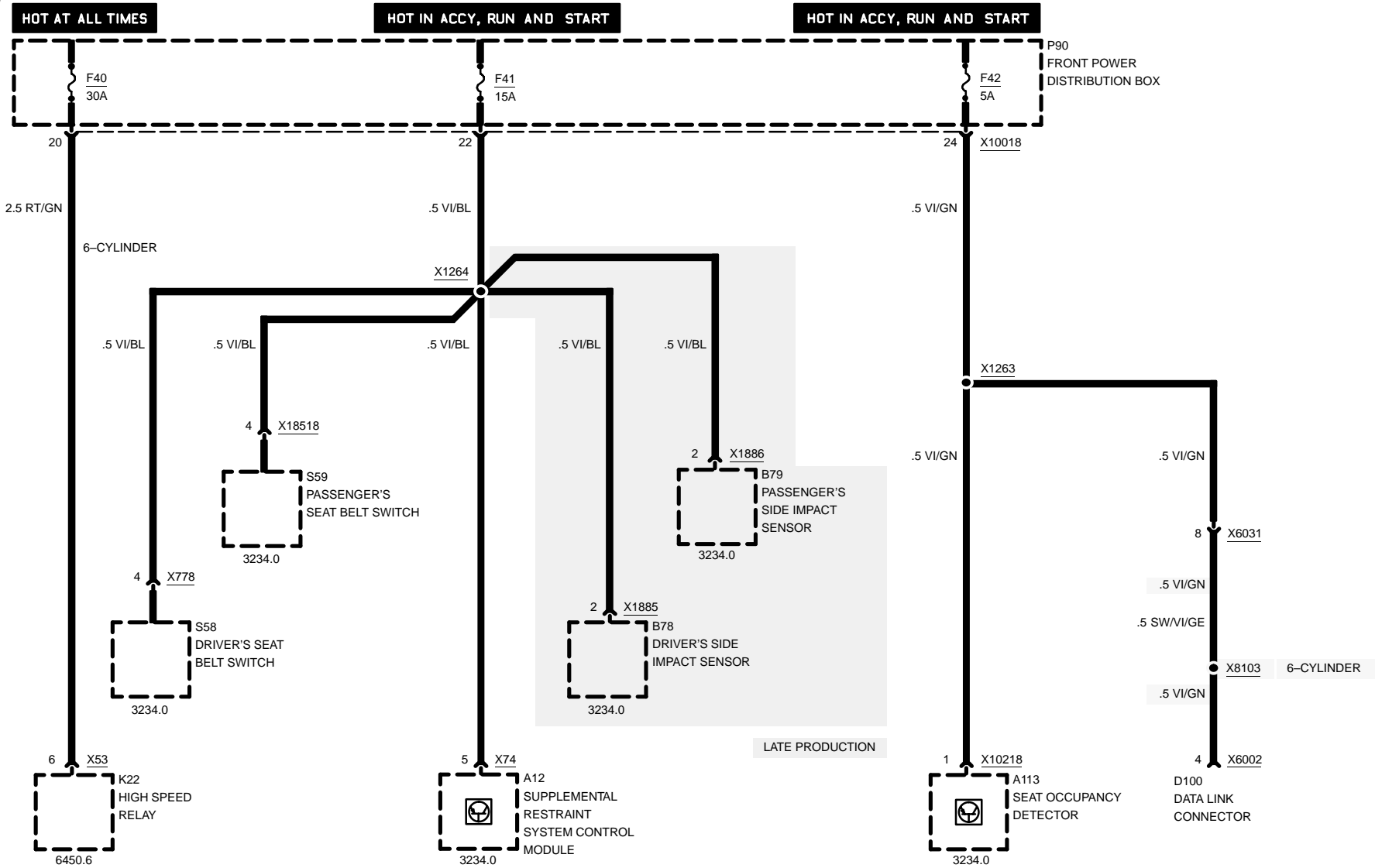



FUSE DETAILS

FUSES 43, 44, AND 45

Z3

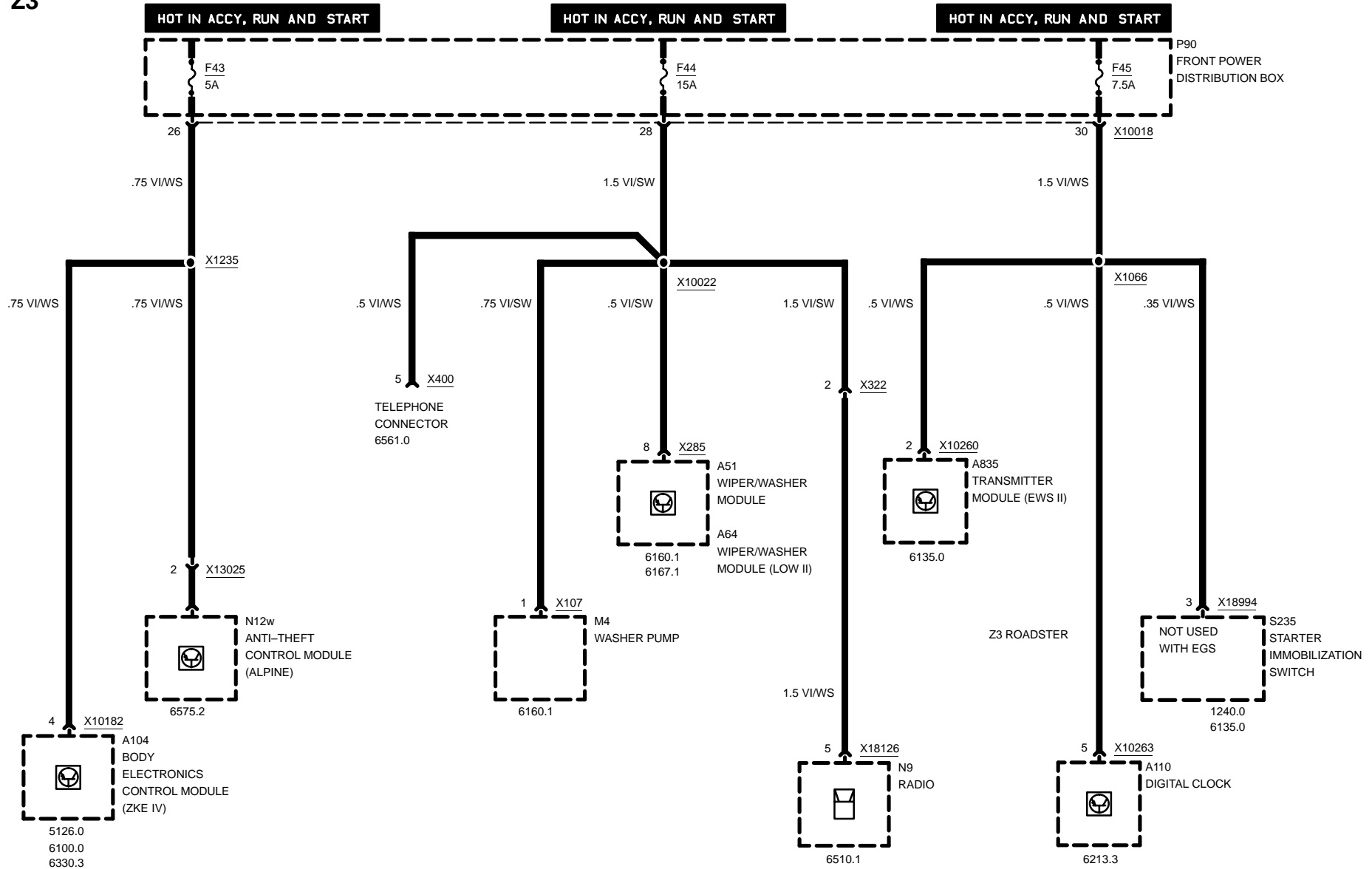



FUSE DETAILS

FUSE 46

HOT IN ACCY, RUN AND START

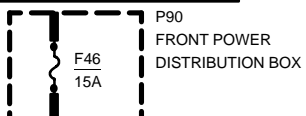

32 X10018

1.5 VI/GE

X1182

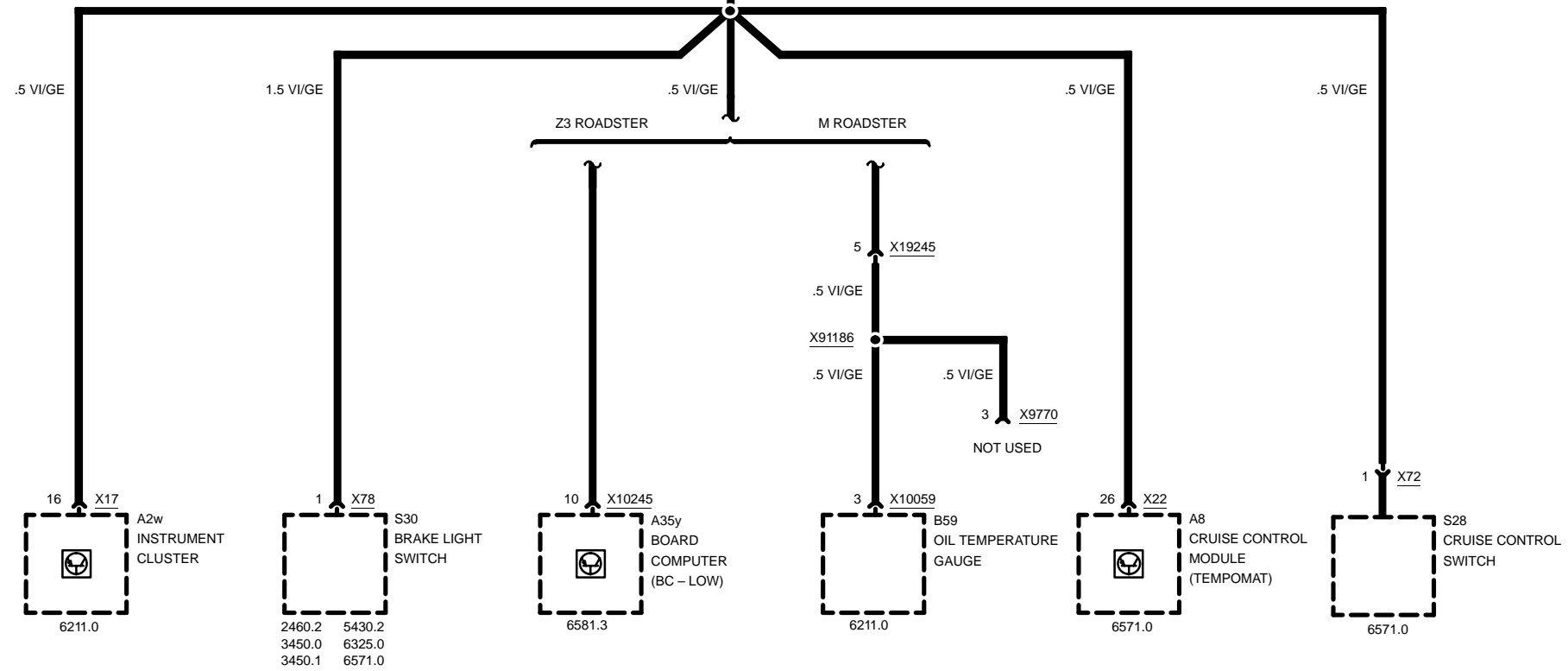



FUSE DETAILS

FUSES 48 AND 49

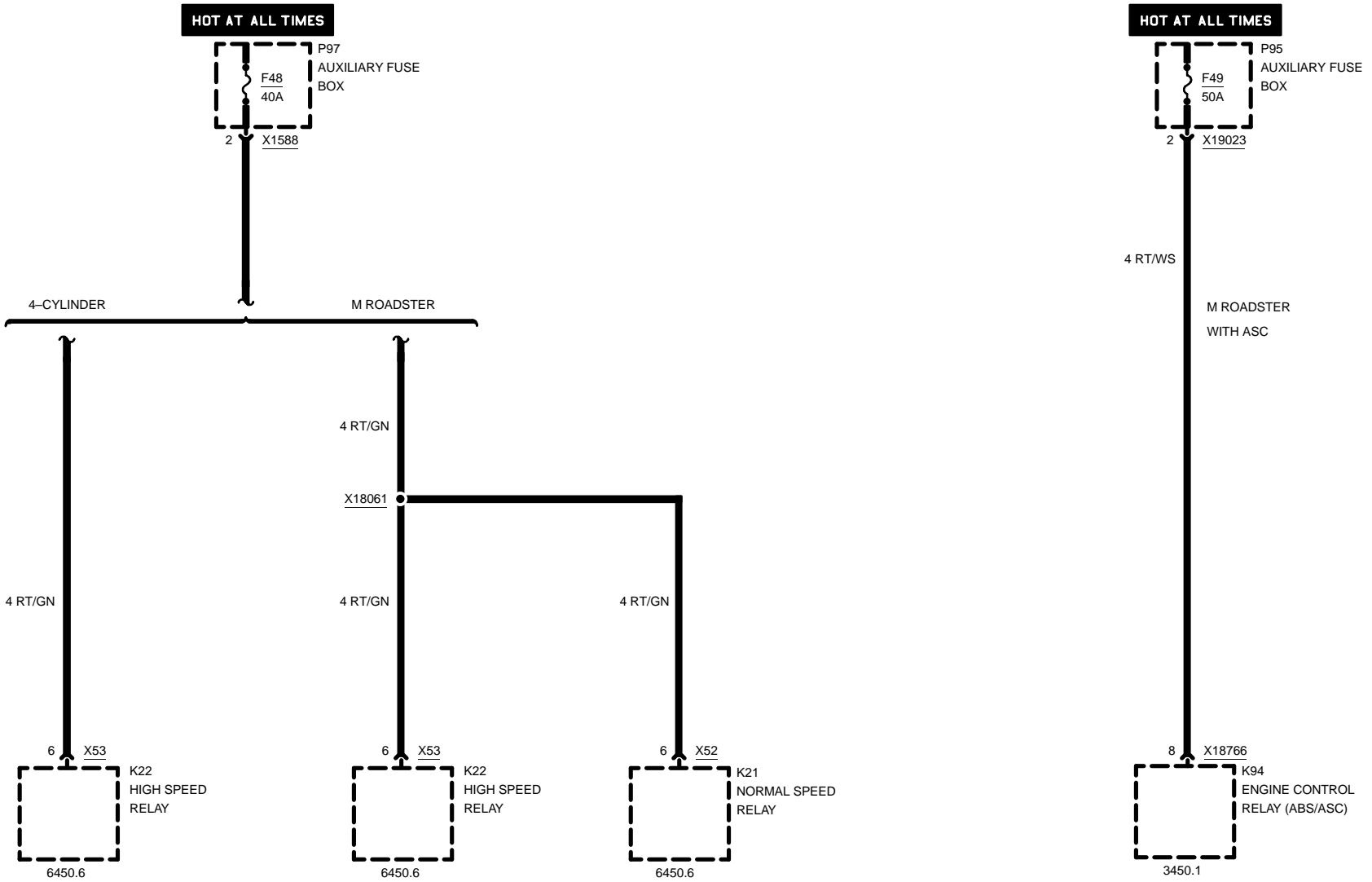



0670.4 GROUND DISTRIBUTION

GROUNDS X4 AND X165

Z3

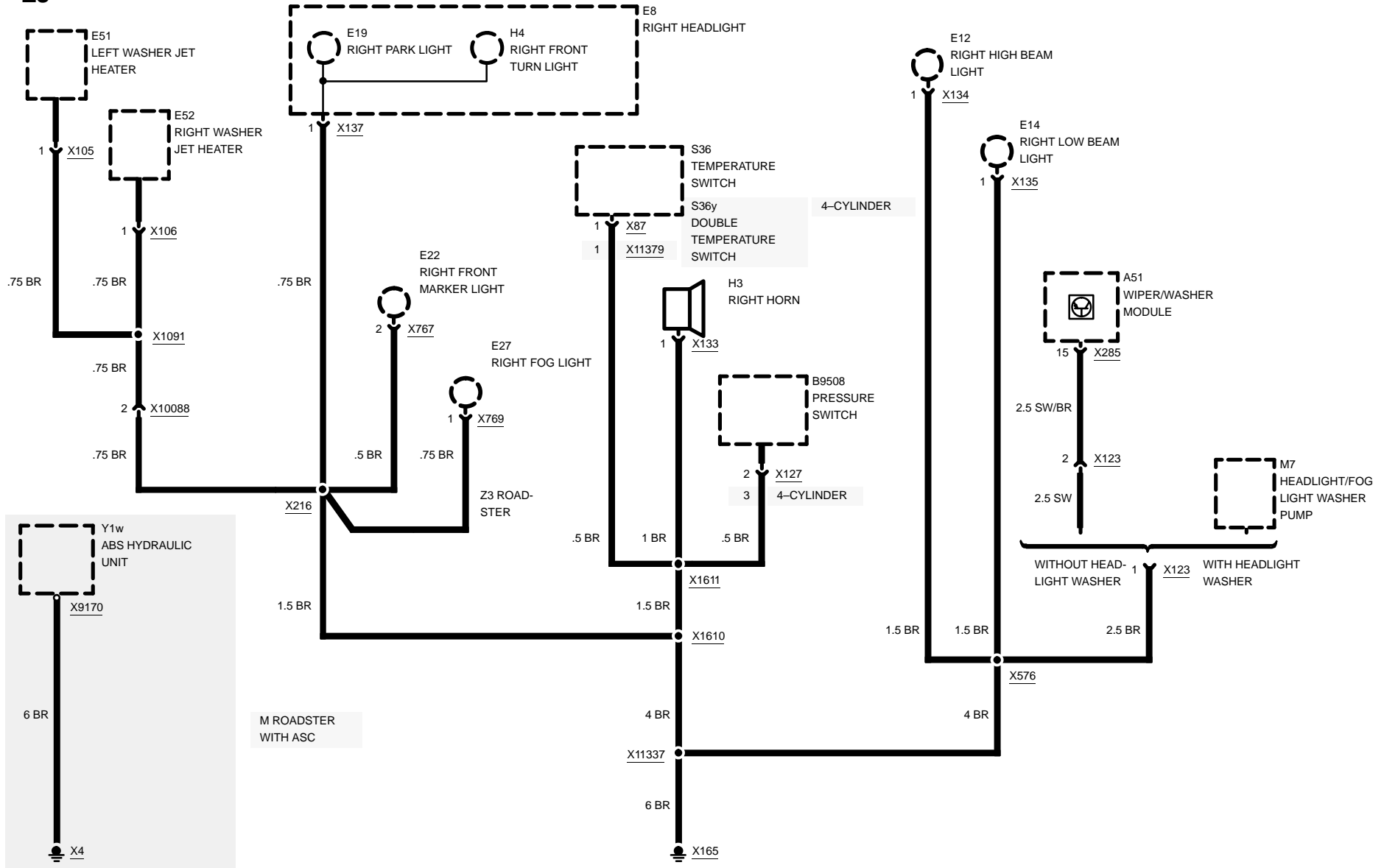

04/99

0670.4-00

1998



GROUND DISTRIBUTION

GROUND X166

Z3

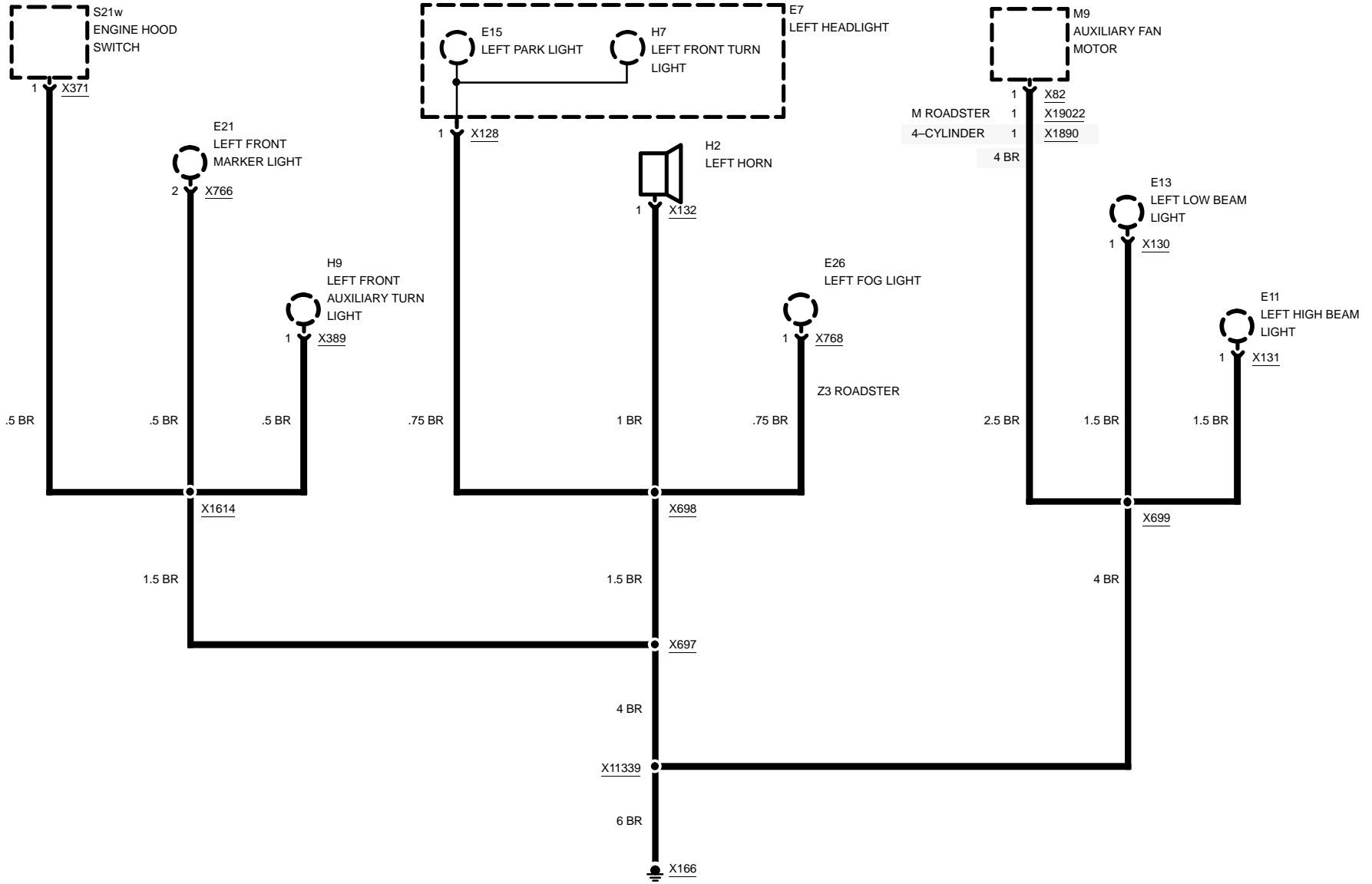



GROUND DISTRIBUTION

GROUNDS X170 AND X494

Z3

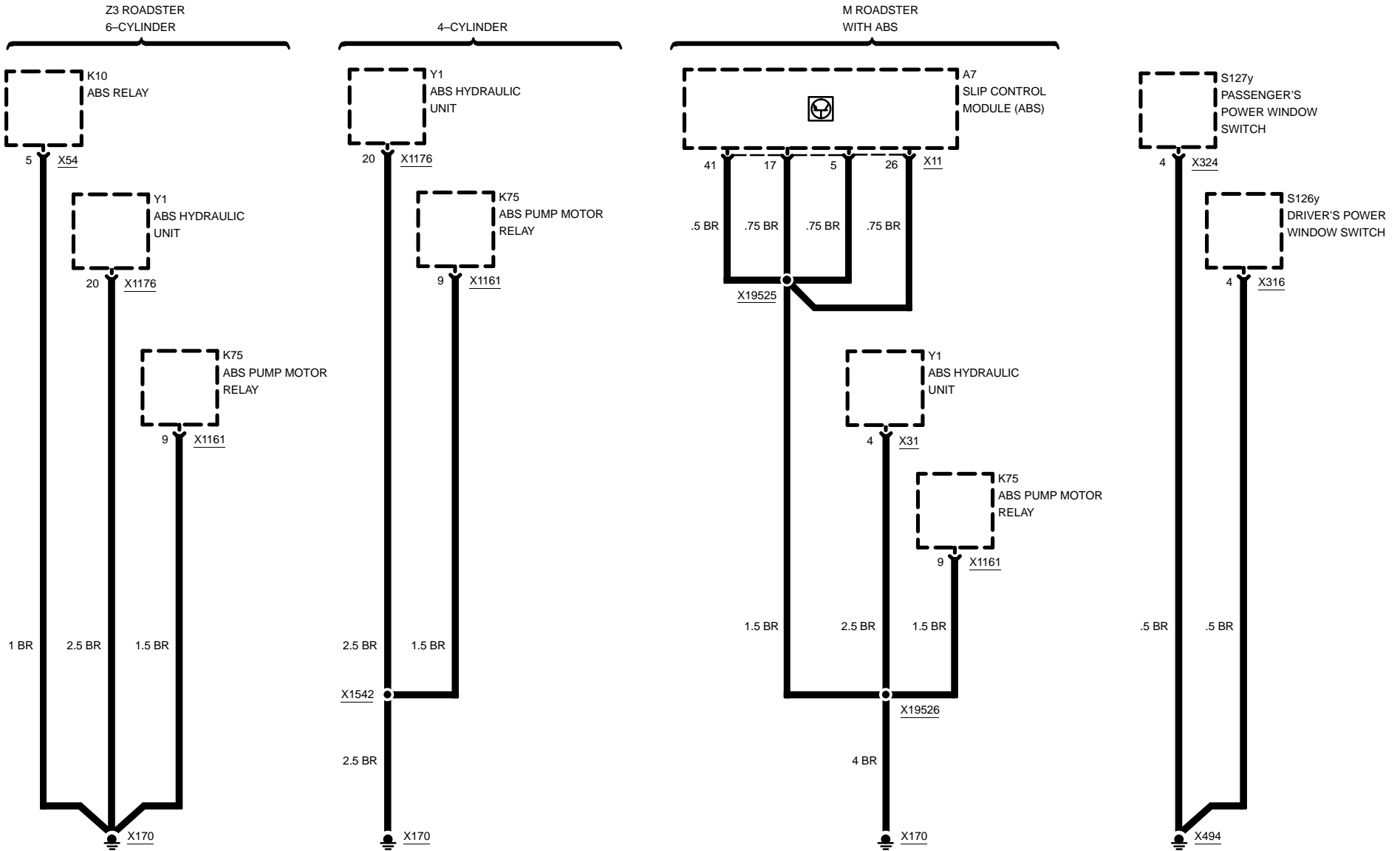



GROUND DISTRIBUTION

GROUNDS X861, X1116, X1166, AND X1441

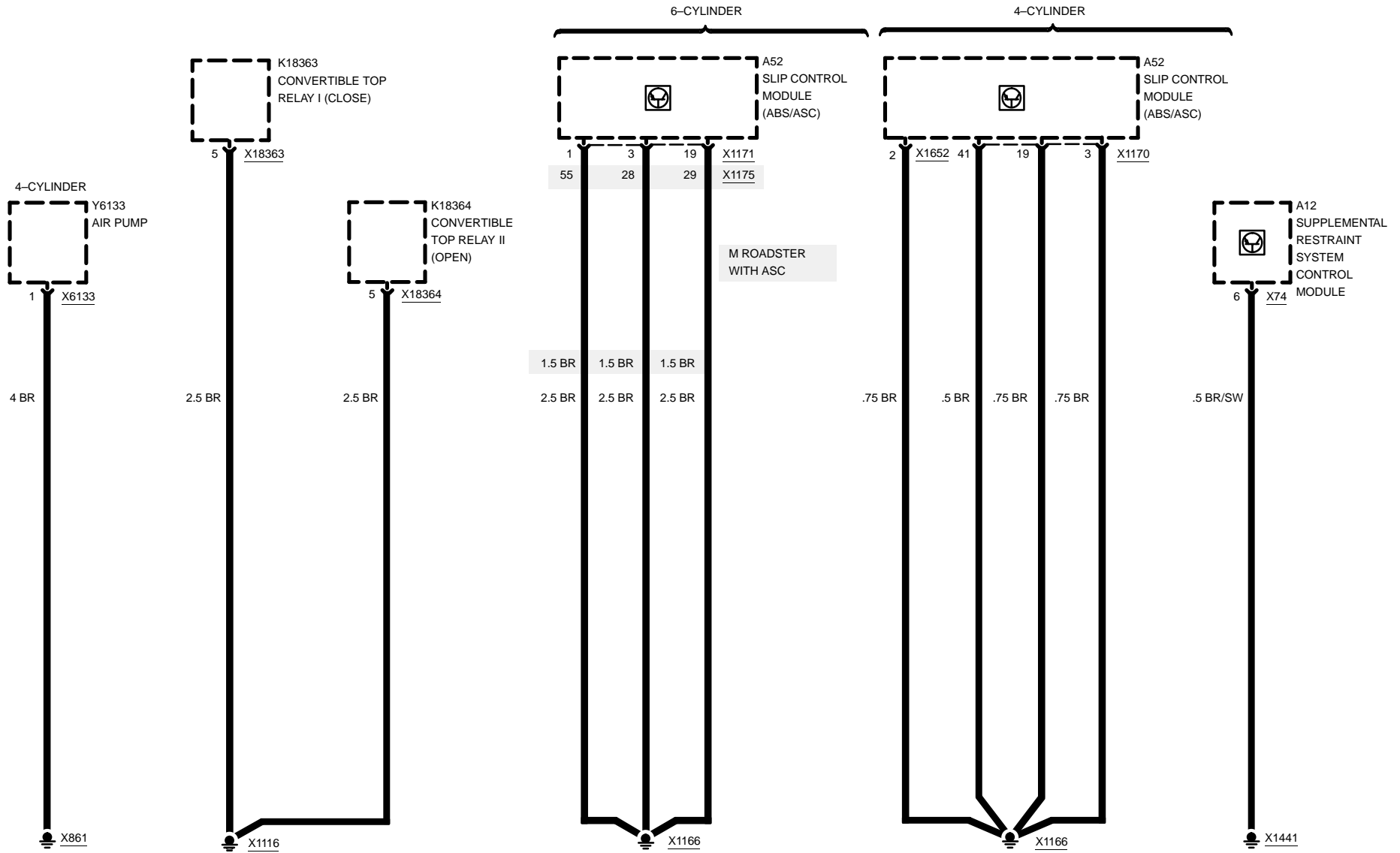



GROUND DISTRIBUTION

4-CYLINDER

GROUND X6454

Z3

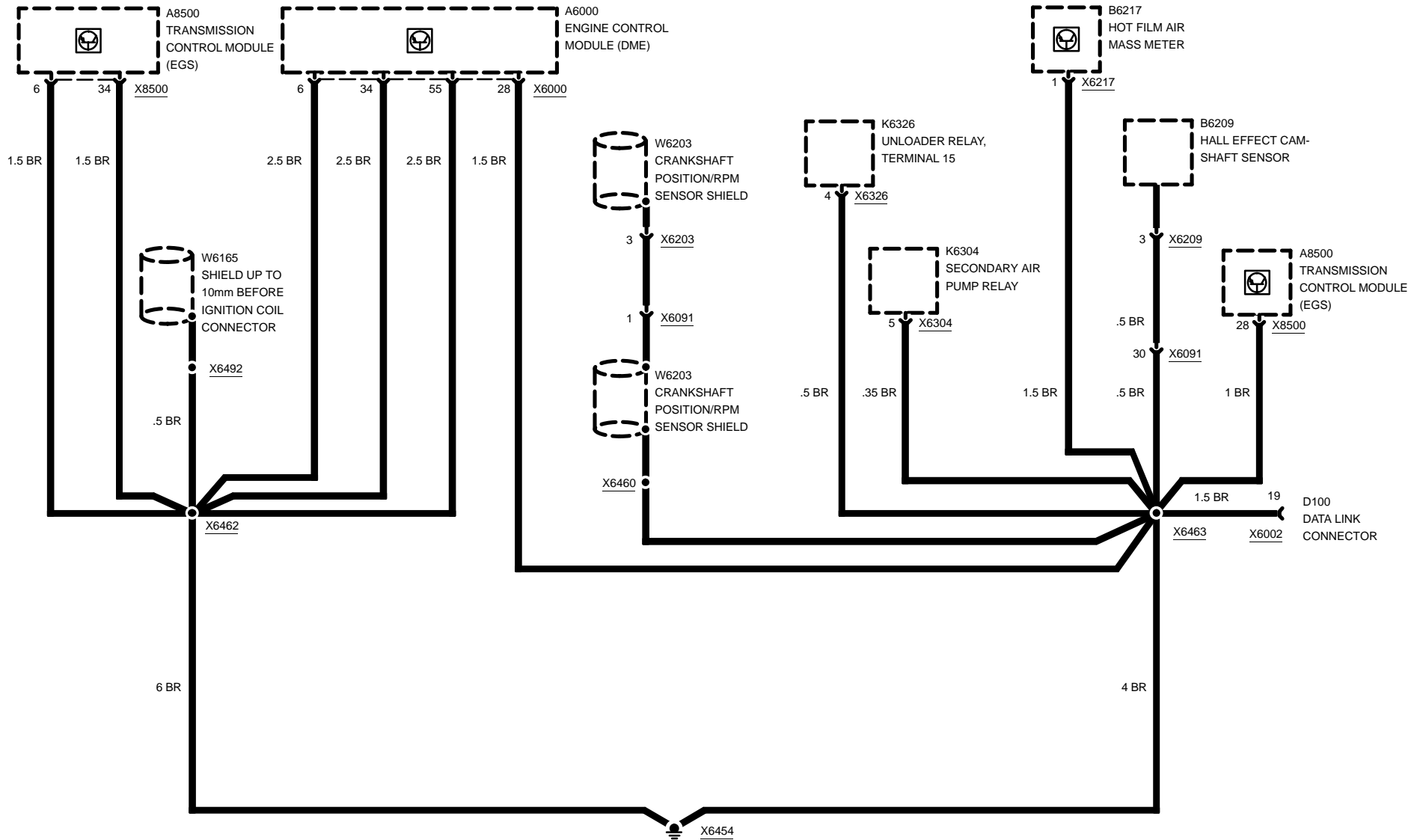

04/99

0670.4-04

1998



GROUND DISTRIBUTION

6-CYLINDER

GROUND X6454

Z3

W6203
CRANKSHAFT
POSITION/RPM
SENSOR SHIELD

W6165
SHIELD UP TO
10mm BEFORE
IGNITION COIL
CONNECTOR

K6326
UNLOADER RELAY,
TERMINAL 15

A6000
ENGINE CONTROL
MODULE (DME)

B6207
HOT FILM AIR
MASS METER

M ROADSTER
M6506
E-BOX FAN

Z3 ROADSTER
A8500
TRANSMISSION
CONTROL MODULE
(EGS)

X6492

4 X6326

32

34

4

28

X6000

1 X6207

1 X6506

34

28 X8500

.5 BR

.5 BR

.5 BR

2.5 BR

1.5 BR

1.5 BR

1.5 BR

1.5 BR/OR

1.5 BR/OR

.5 BR/OR

X6458

4 BR

X6459

4 BR/OR

1.5 BR/OR

19 D100
DATA LINK
CONNECTOR
X6002

X6454

04/99

0670.4-05

1998



GROUND DISTRIBUTION

4-CYLINDER

GROUND X6456

Z3

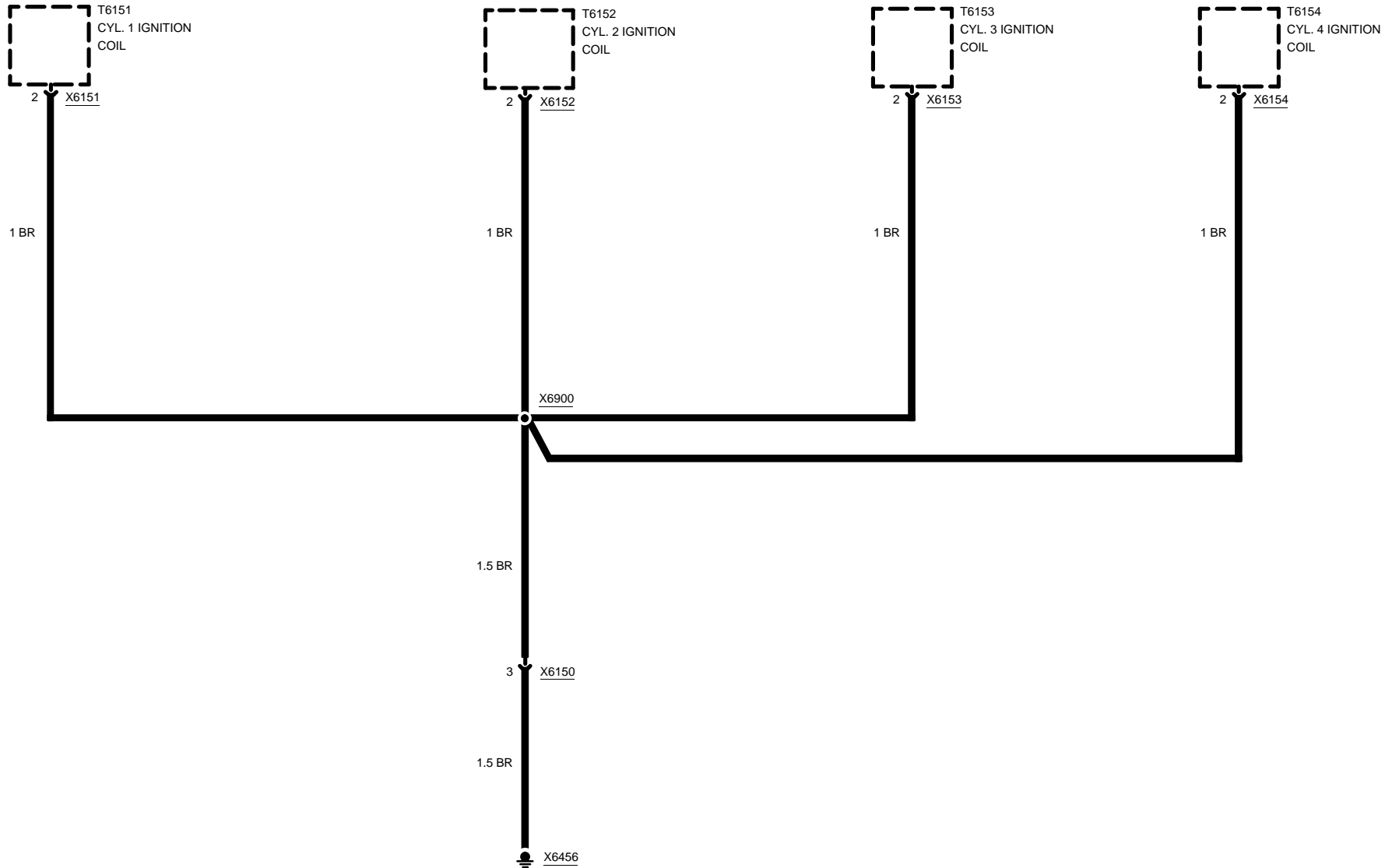

04/99

0670.4-06

1998



GROUND DISTRIBUTION GROUNDS X6455 AND X6456

6-CYLINDER

Z3

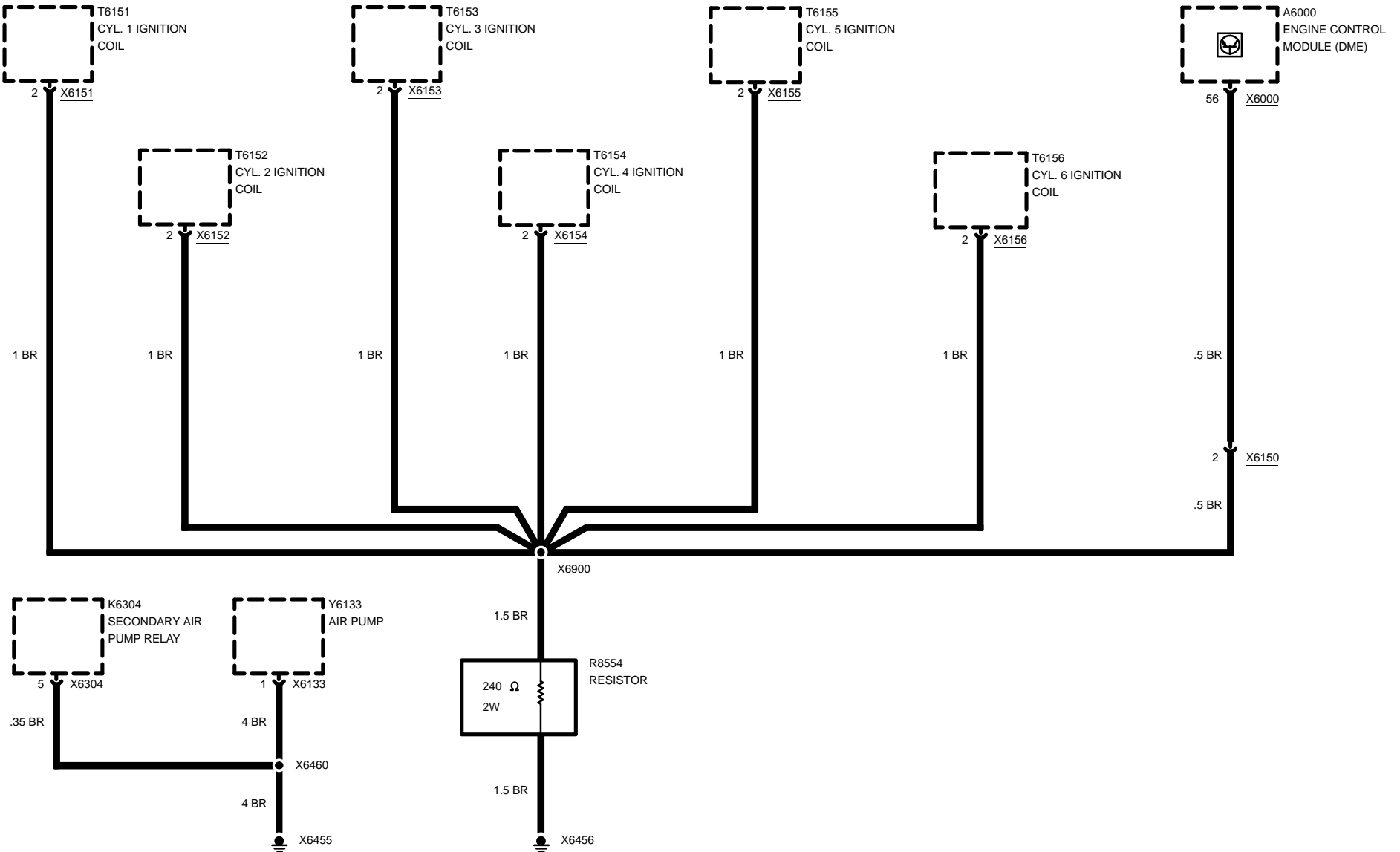

04/99

0670.4-07

1998



GROUND DISTRIBUTION

GROUND X9633

Z3

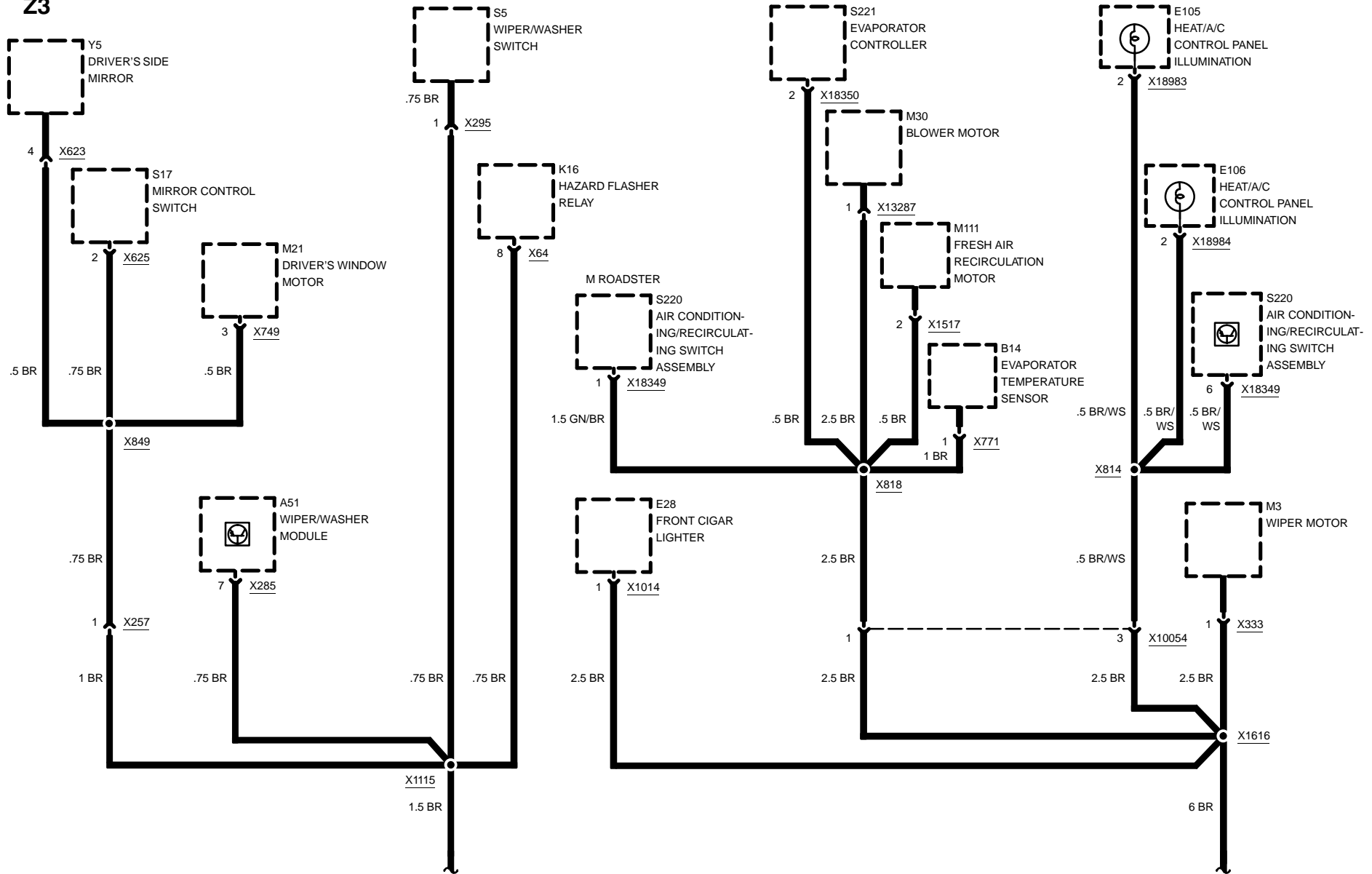

04/99

0670.4-08

1998

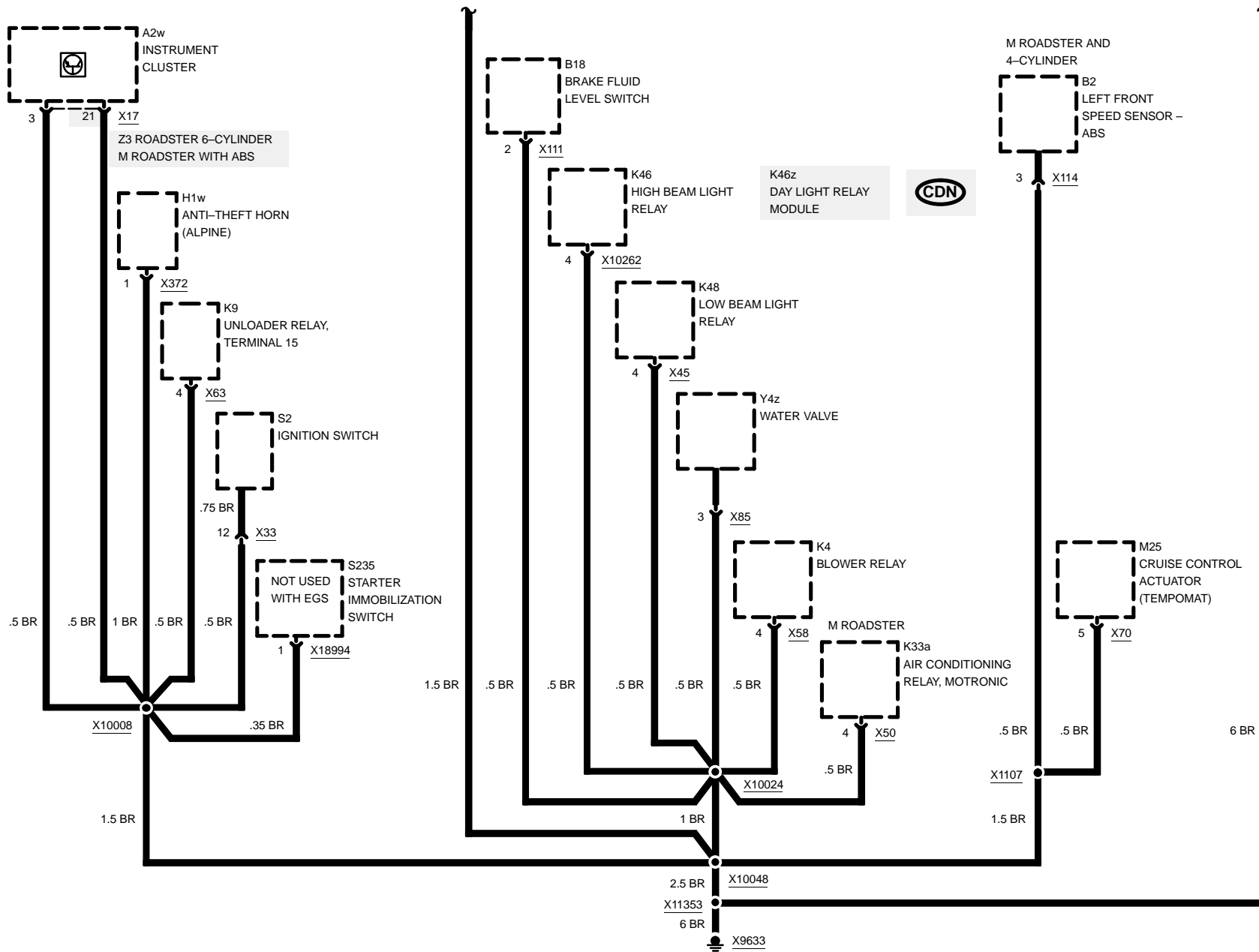



GROUND DISTRIBUTION

GROUND X10010

Z3

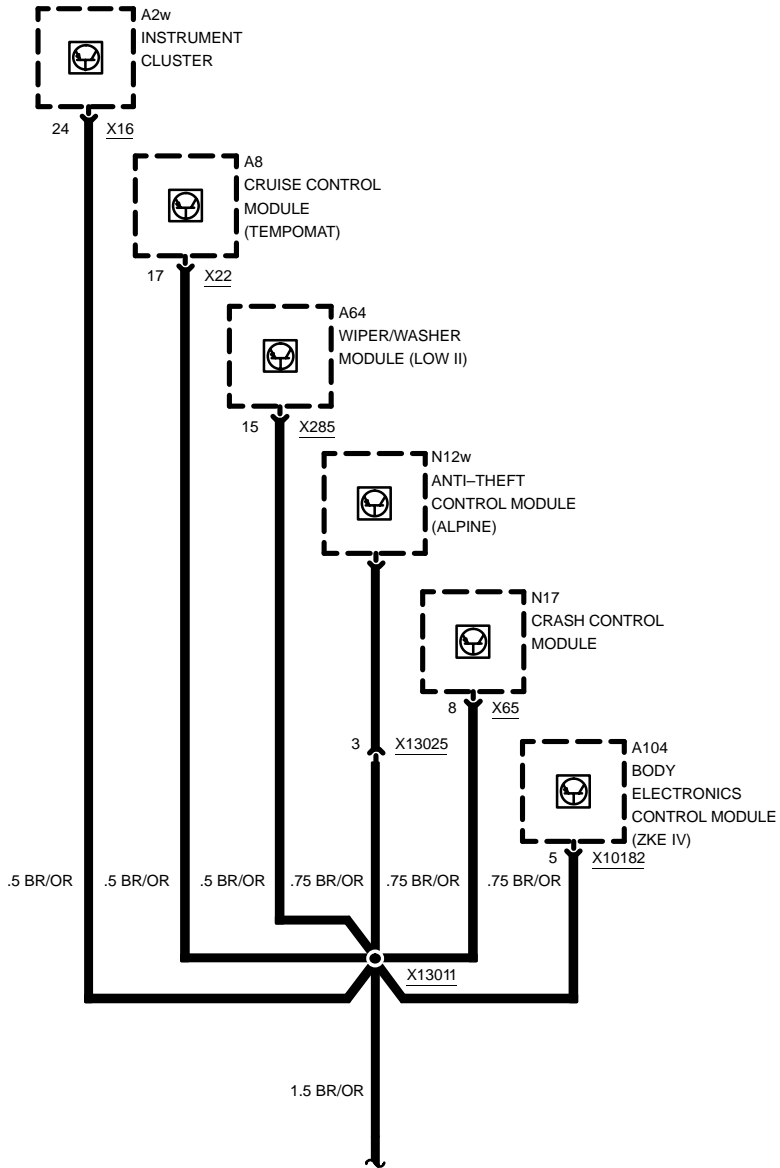

LATE PRODUCTION

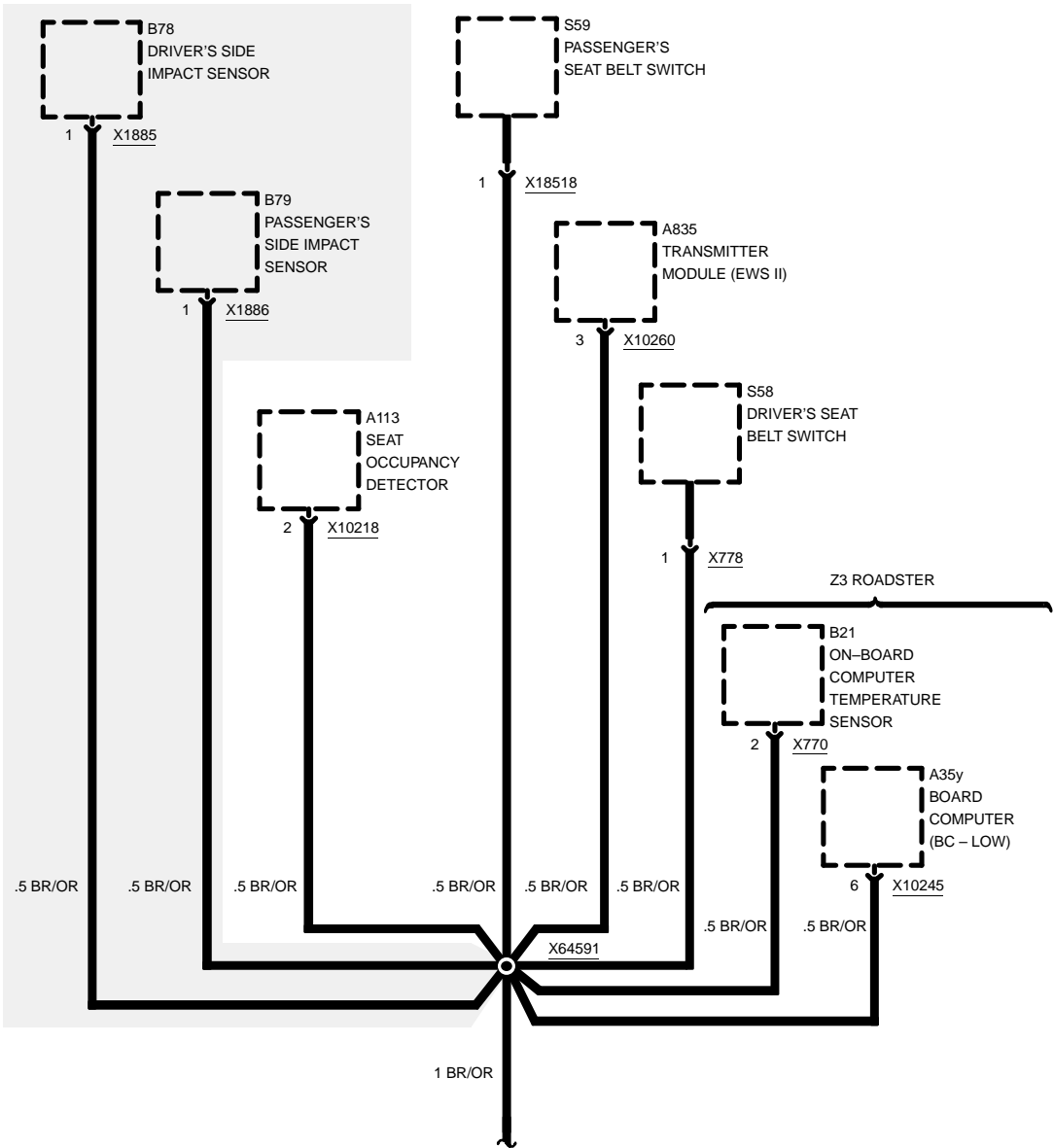

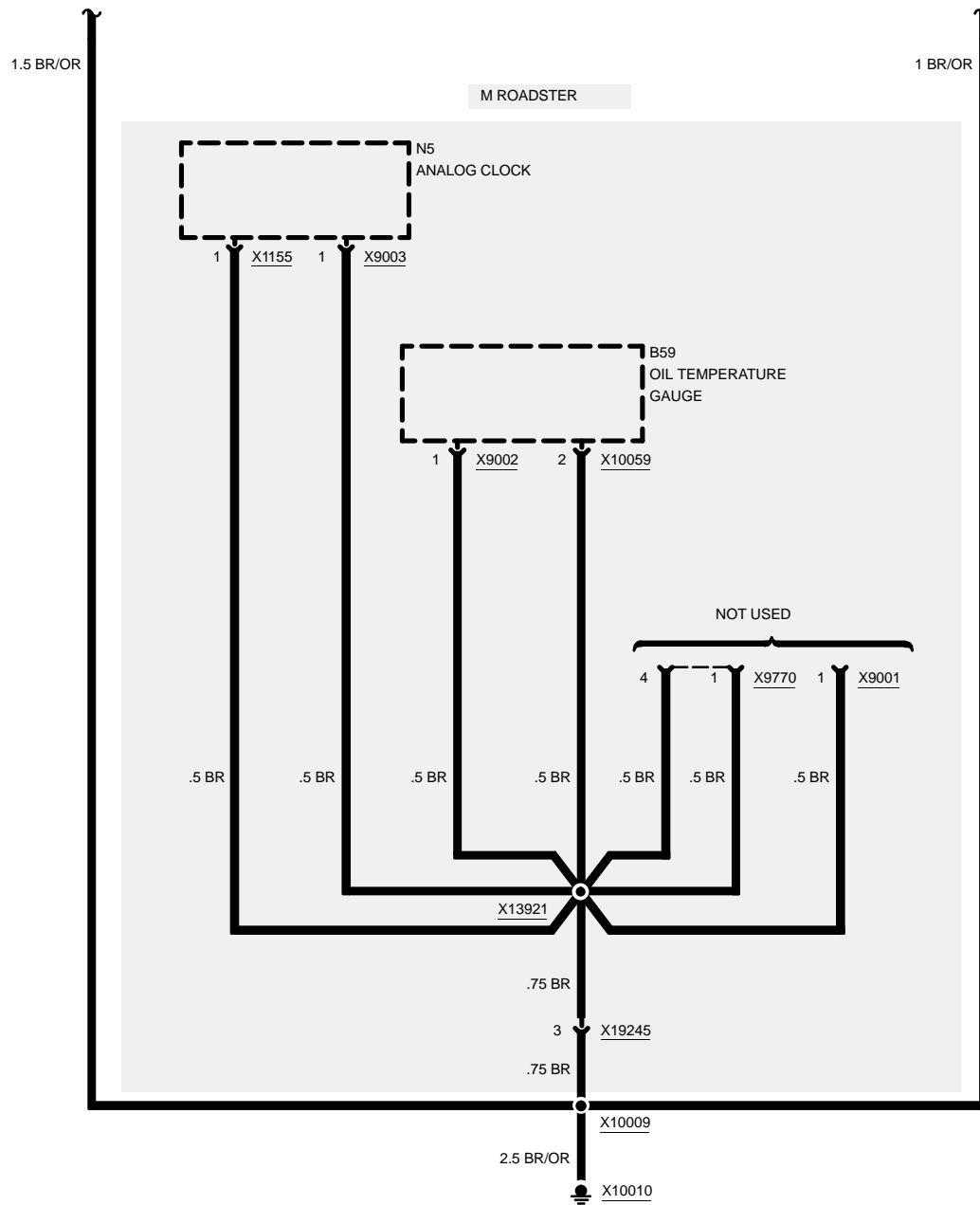



GROUND DISTRIBUTION

GROUND X13004

Z3

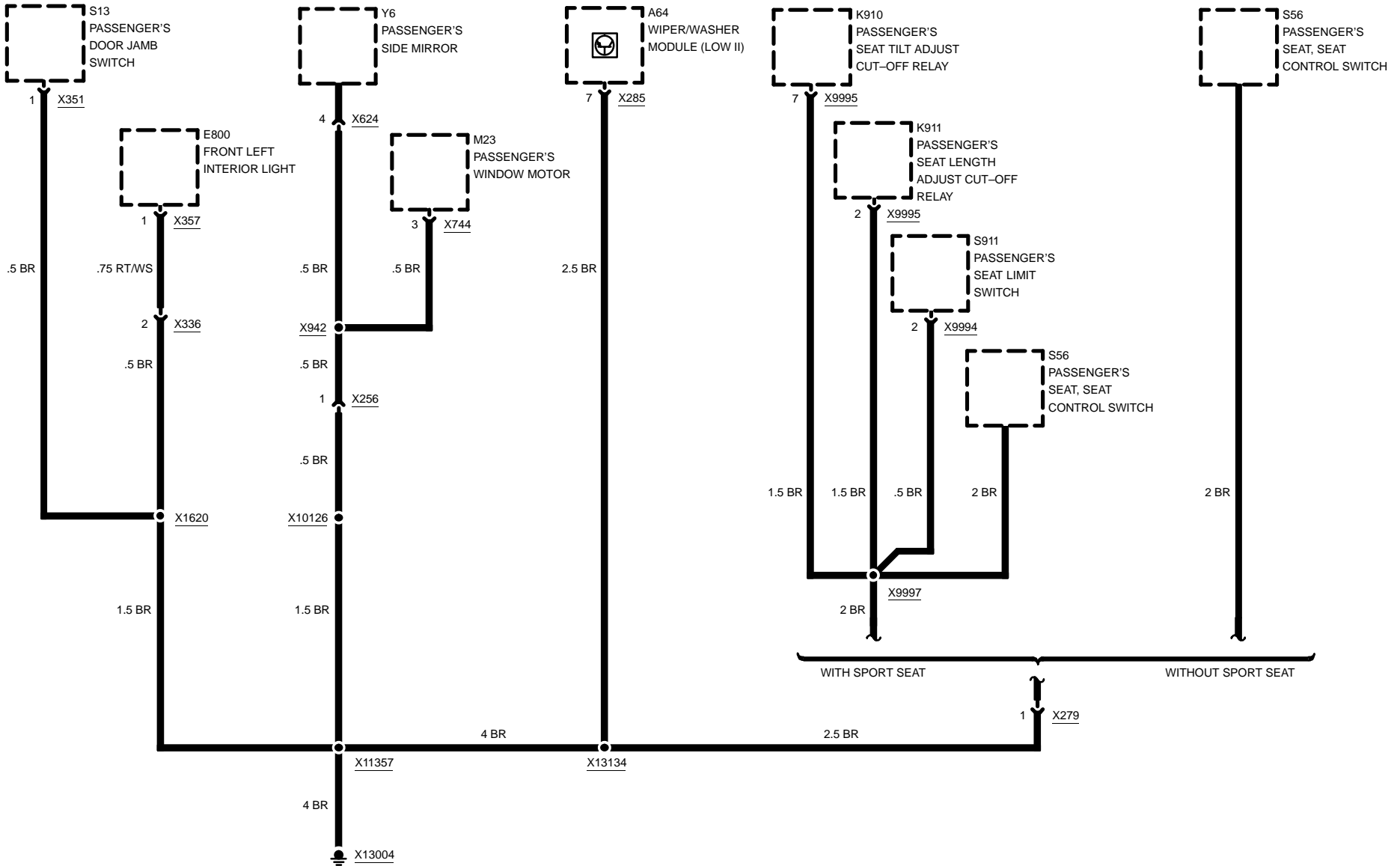

04/99

0670.4-12

1998



Z3

GROUND DISTRIBUTION

GROUND X13006

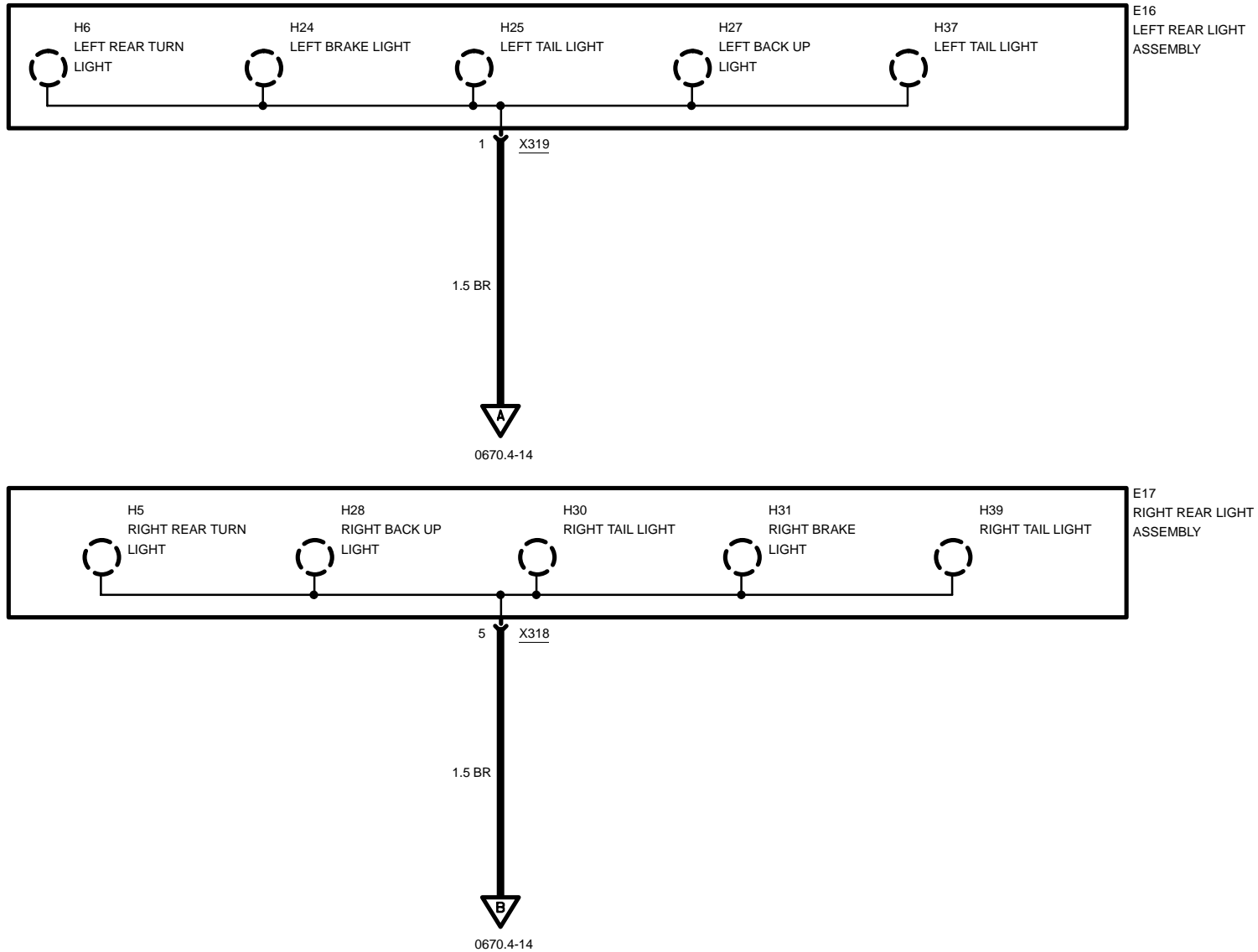



GROUND DISTRIBUTION

GROUND X13006

Z3

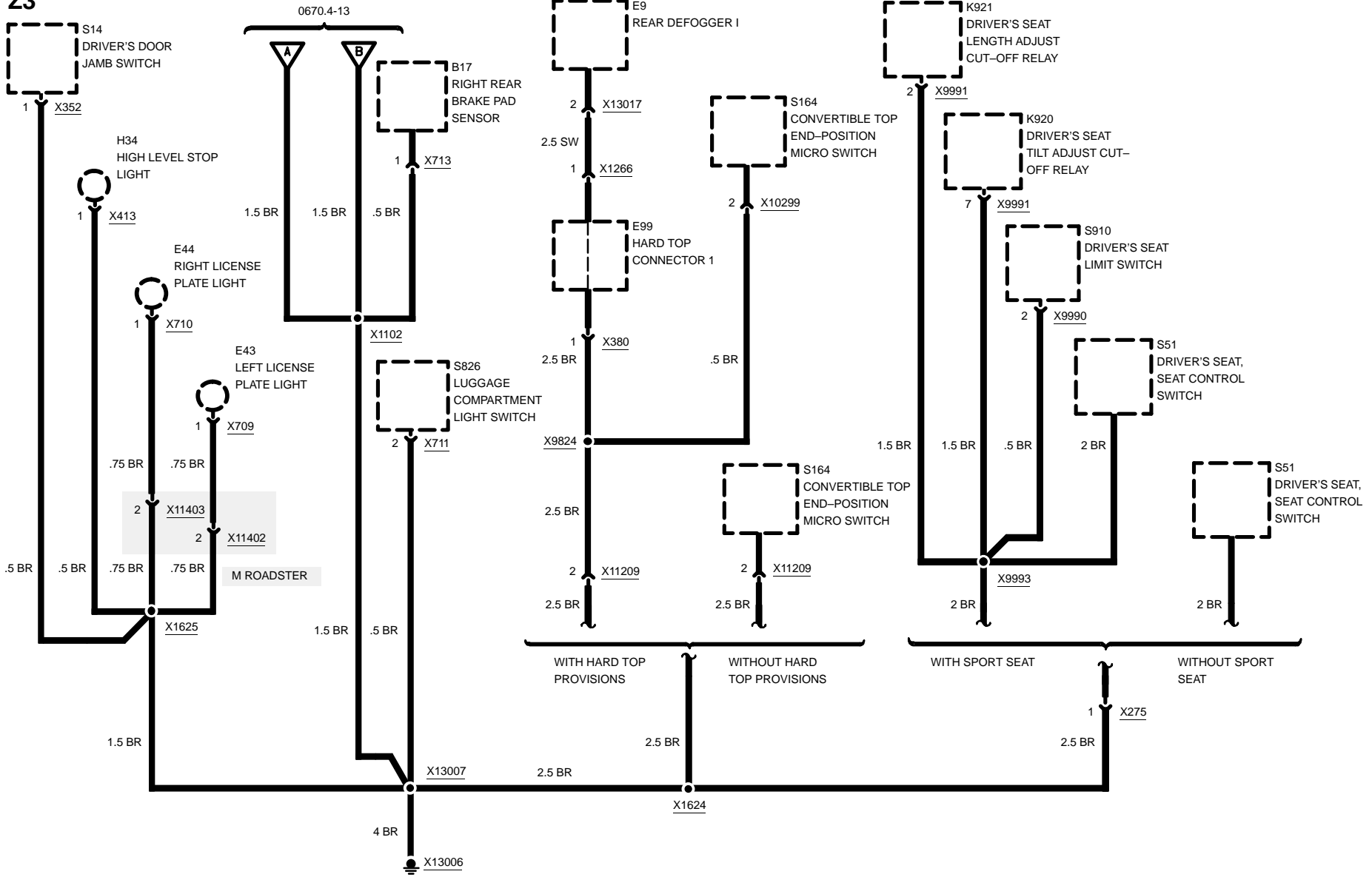

04/99

0670.4-14

1998



GROUND DISTRIBUTION

GROUPS X13016 AND X13032

Z3

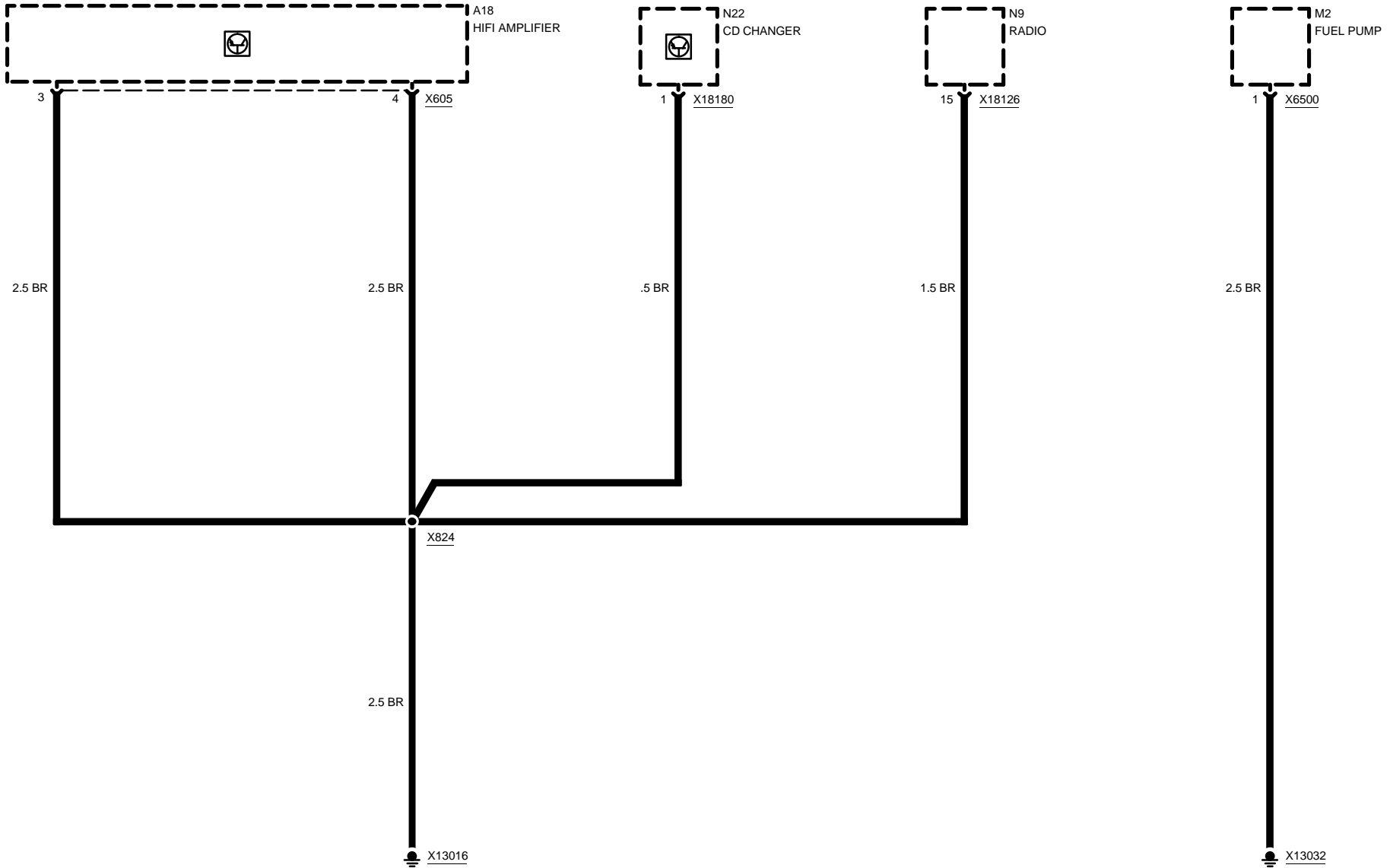

04/99

0670.4-15

1998



GROUND DISTRIBUTION

GROUND X18170

Z3

TELEPHONE CONNECTOR

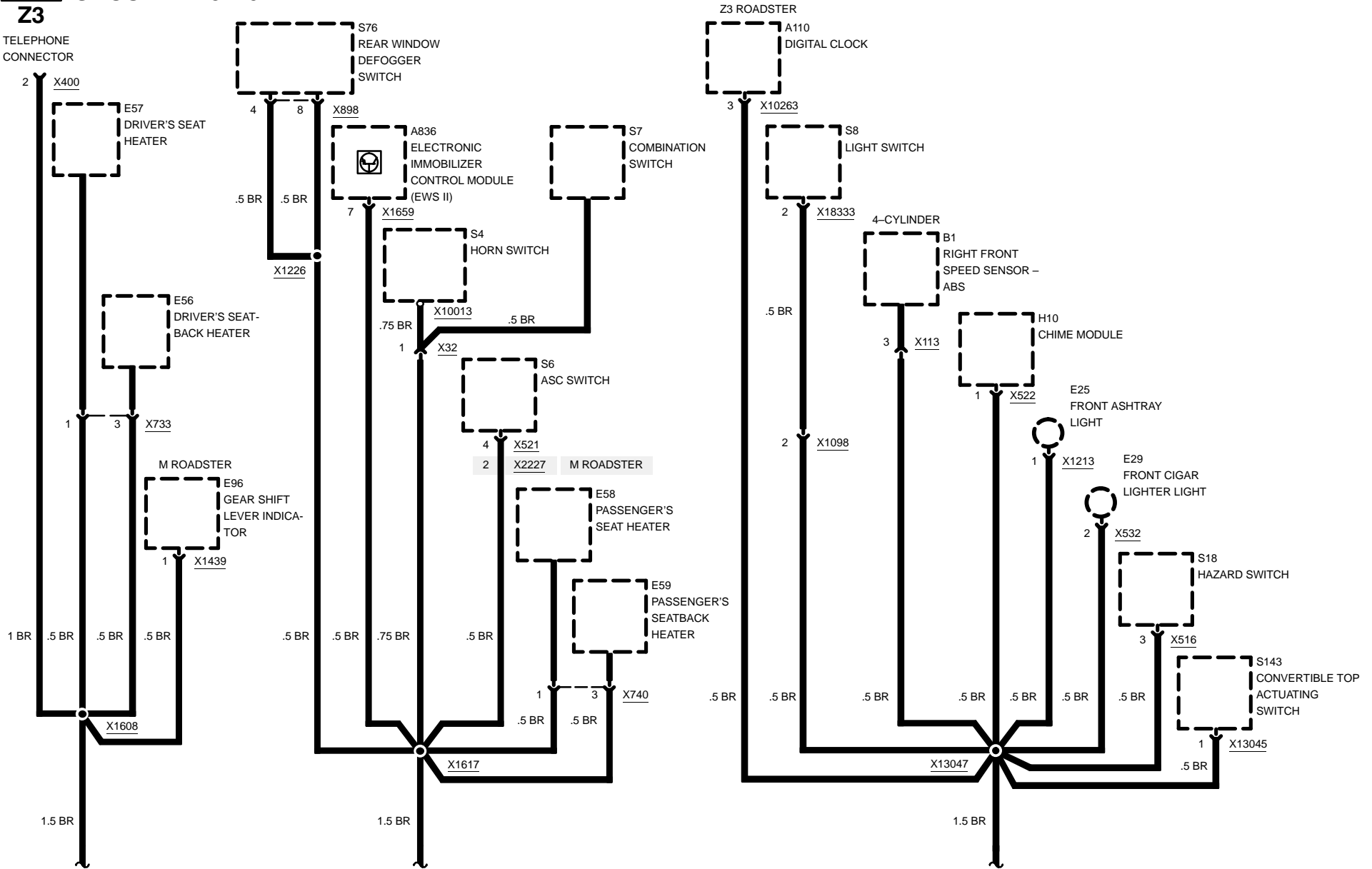

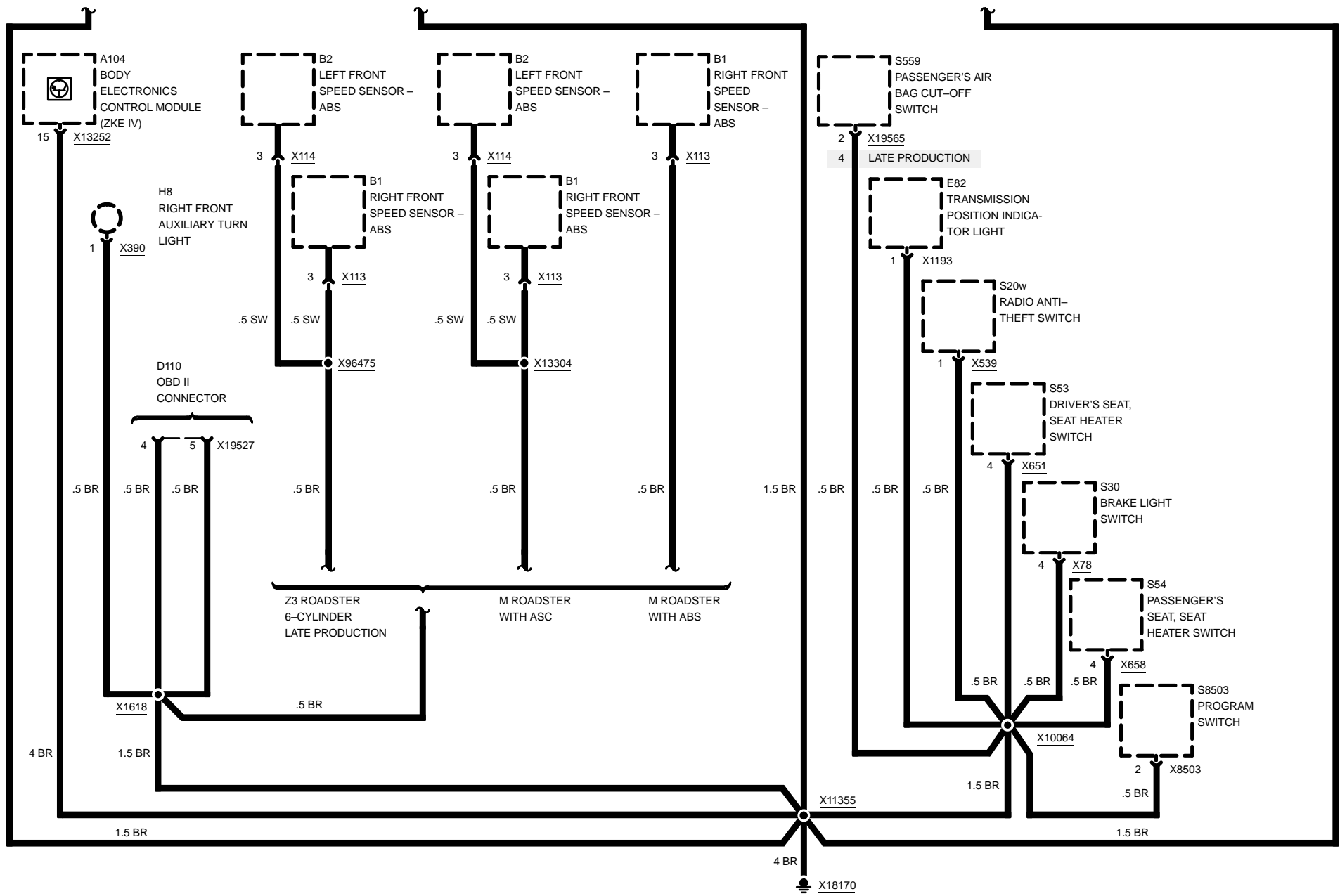



0670.5 DATA LINK BLOCK DIAGRAM

Z3

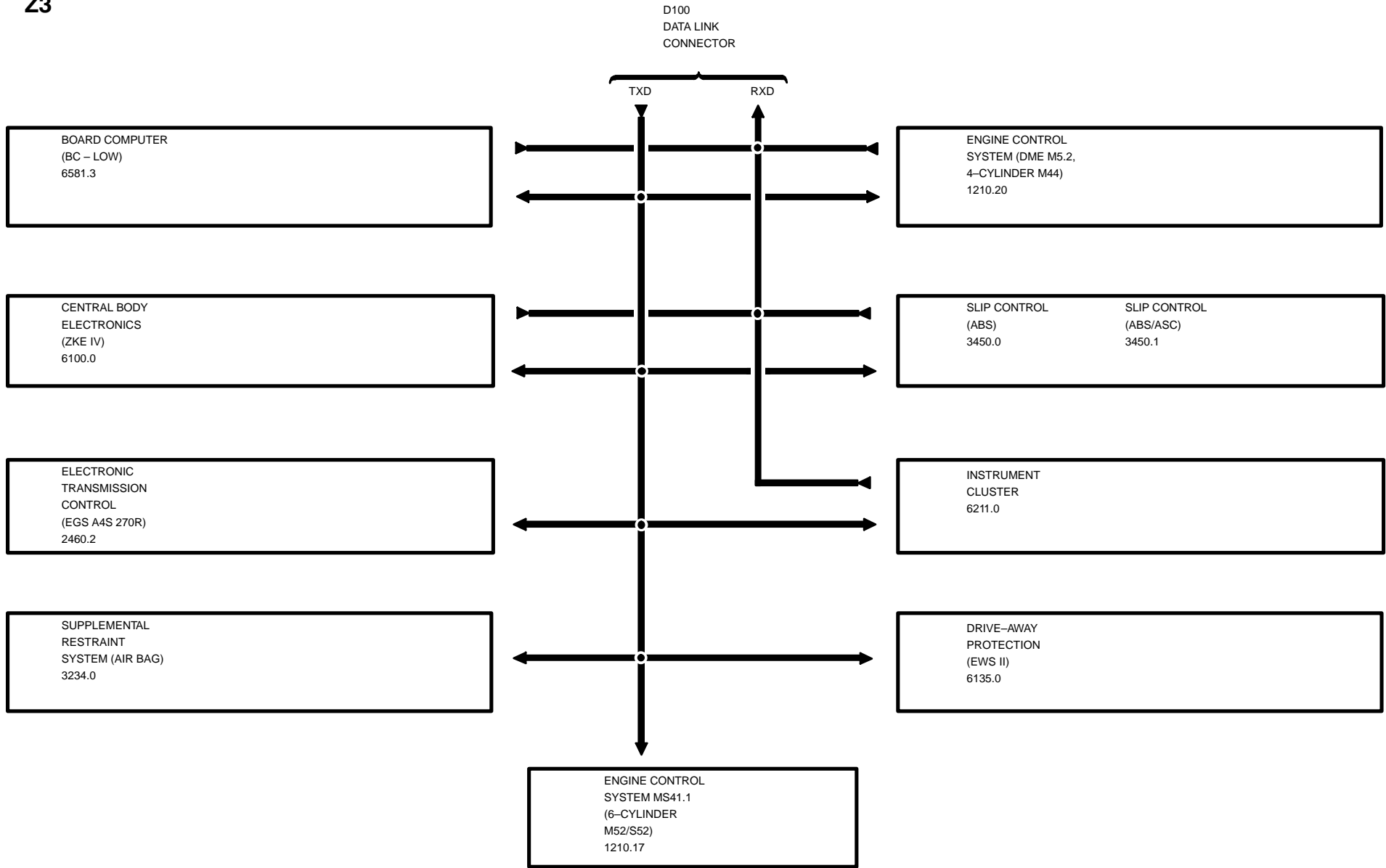



DATA LINK

TXD

Z3

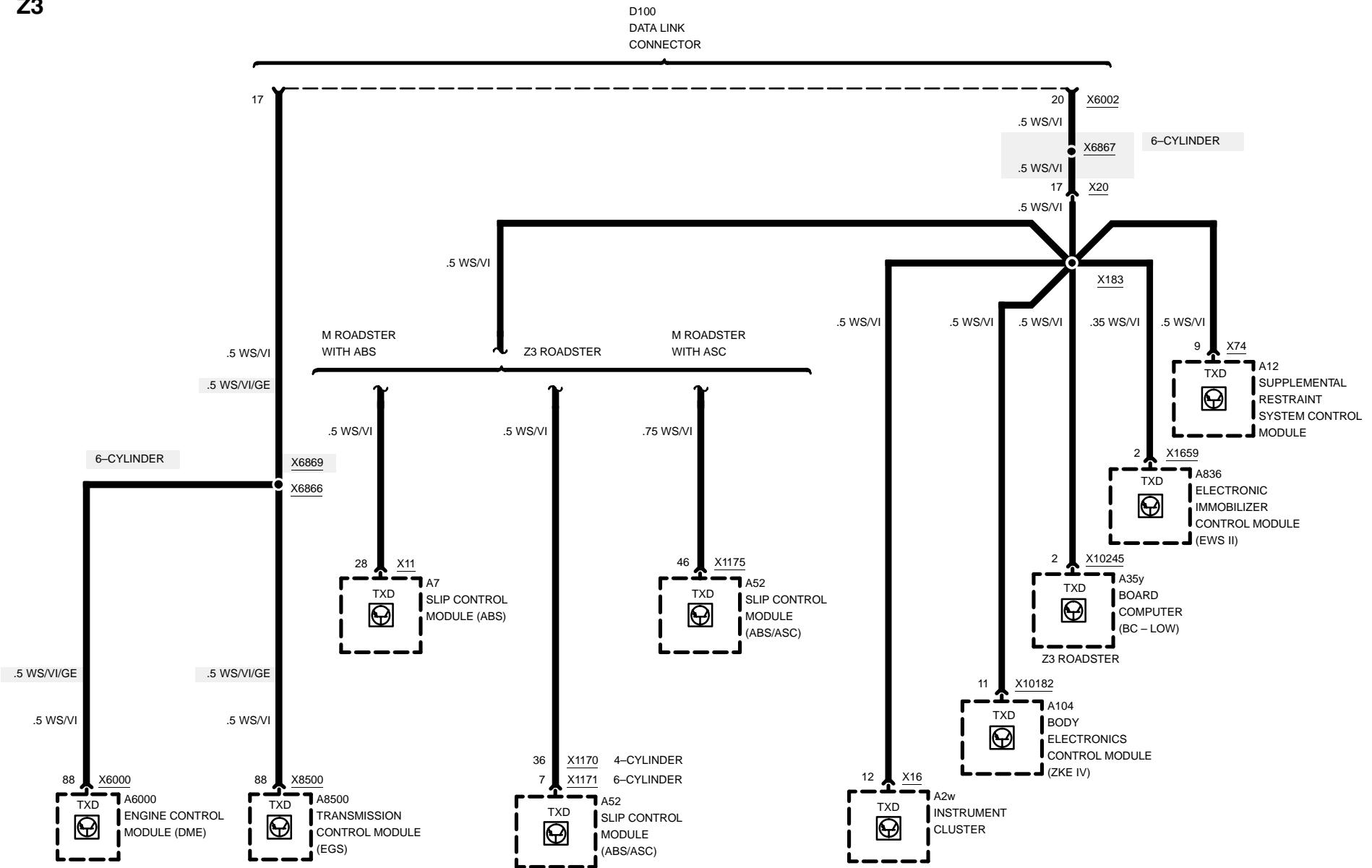

04/99

0670.5-01

1998



DATA LINK

RXD

Z3

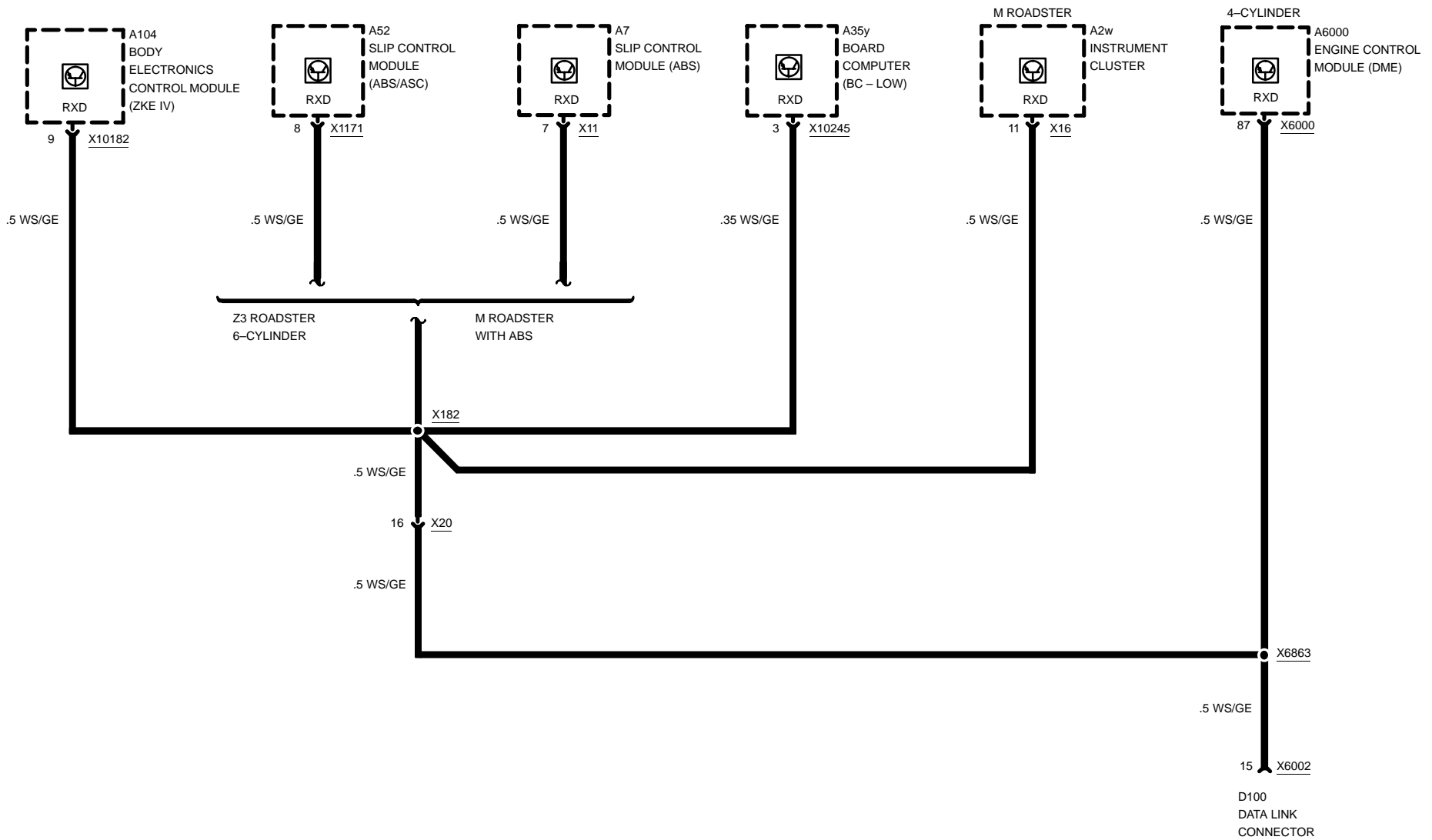



DATA LINK

DATA LINK CONNECTOR, PINS 1, 7, 14, AND 16

Z3

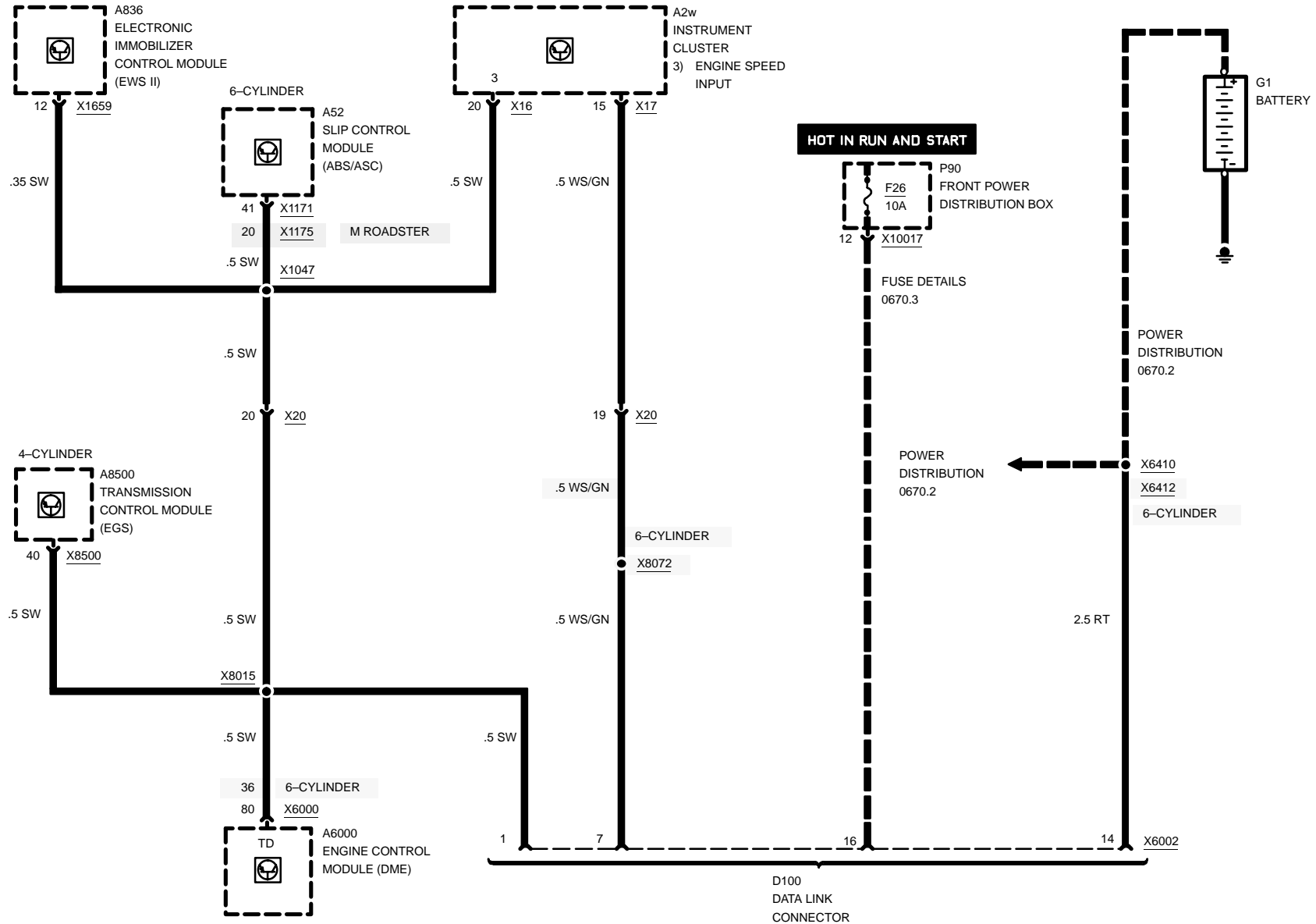



DATA LINK

DATA LINK CONNECTOR, PINS 4, 12, 18, AND 19

Z3

HOT IN ACCY, RUN AND START

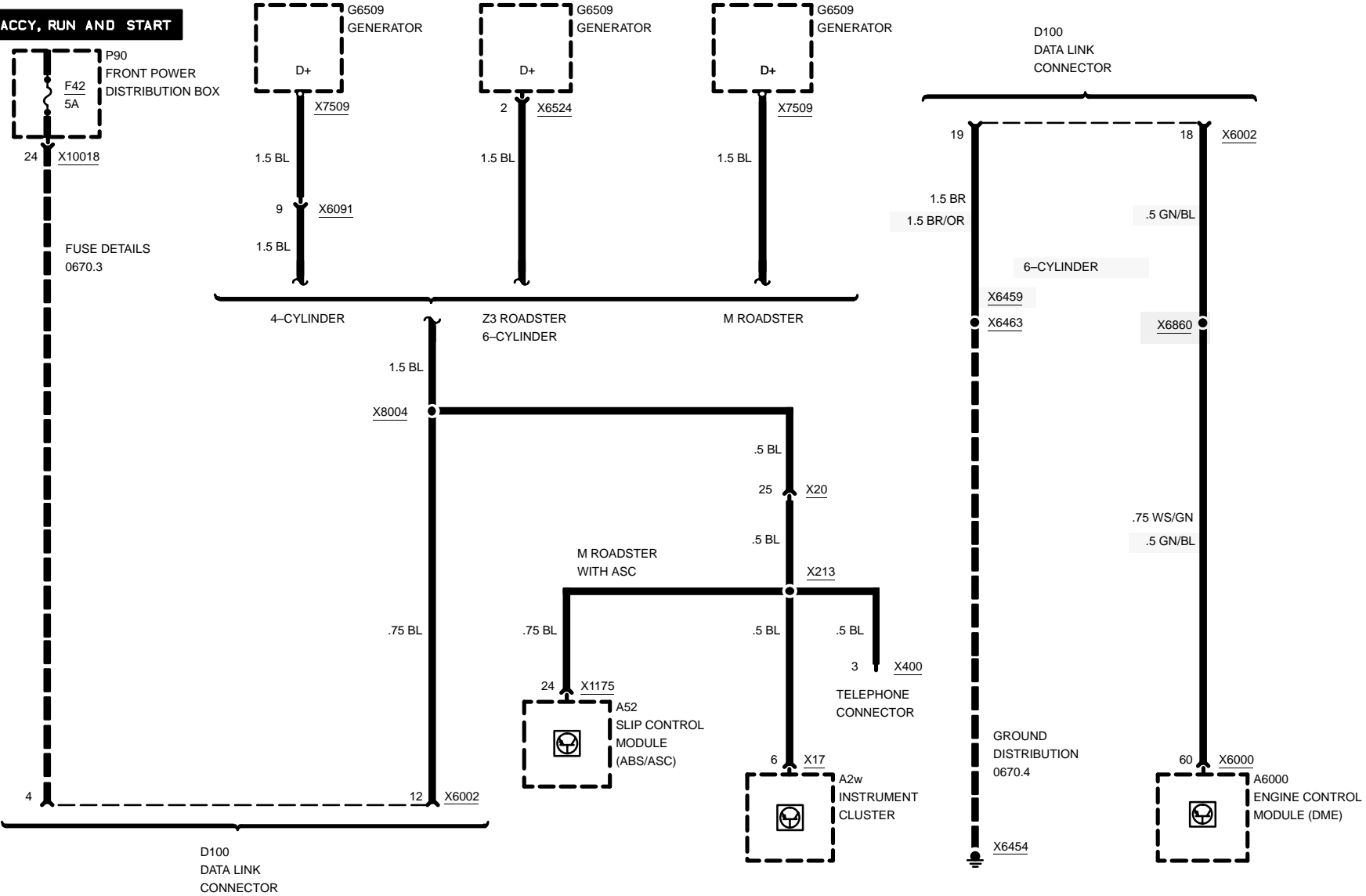

04/99

0670.5-04

1998



DATA LINK

DATA LINK CONNECTOR, PIN 2 AND OBD II CONNECTOR

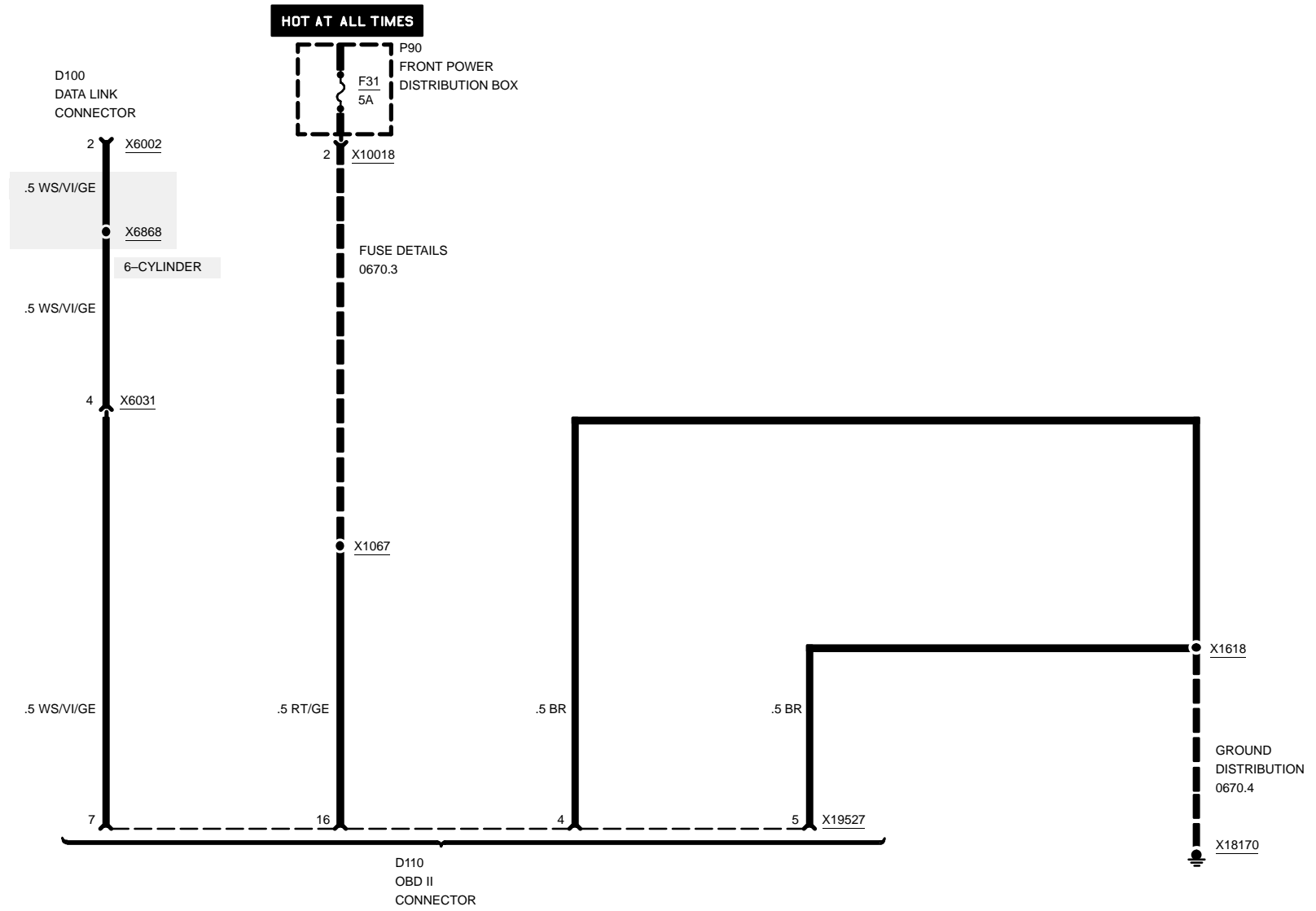



DATA LINK

DATA LINK CONNECTOR (X6002)

Z3

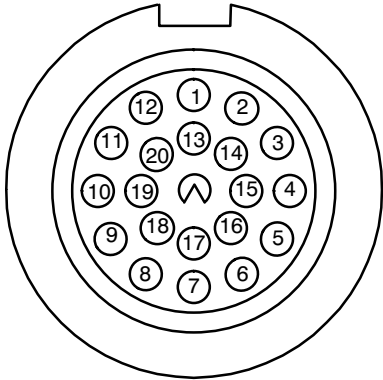

BRIDGES IN CAP OF D100 DATA LINK CONNECTOR

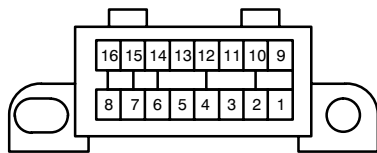
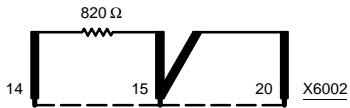

BRIDGE IN CAP OF D110 OBD II CONNECTOR



PIN NUMBER	TERMINAL NUMBER	TERMINAL DESCRIPTION	WIRE COLOR
1	TD	ENGINE	SW
2	TXD2	DIAGNOSTIC DATA LINK	WS/VI/GE
3	—	NOT OCCUPIED	
4	R	VOLTAGE: HOT IN ACCY, RUN AND START	SW/VI/GE (*VI/GN)
5	—	NOT OCCUPIED	
6	—	NOT OCCUPIED	
7	SI	SERVICE INTERVAL RESET	WS/GN
8	—	NOT OCCUPIED	
9	—	NOT OCCUPIED	
10	—	NOT OCCUPIED	
11	—	NOT OCCUPIED	
12	61(D+)	GENERATOR CHARGE INDICATOR	BL
13	—	NOT OCCUPIED	
14	30	VOLTAGE: HOT AT ALL TIMES	RT
15	RXD	DIAGNOSTIC DATA LINK	WS/GE
16	15S	VOLTAGE: IGNITION SWITCH IN RUN AND START	GN/WS
17	TXD2	DIAGNOSTIC DATA LINK	WS/VI (*WS/VI/GE)
18	PGSP	PROGRAM SELECT FOR ENGINE CONTROL MODULE (DME)	WS/GN (*GN/BL)
19	31	GROUND	BR (*BR/OR)
20	TXD	DIAGNOSTIC DATA LINK	WS/VI

* 6-CYLINDER

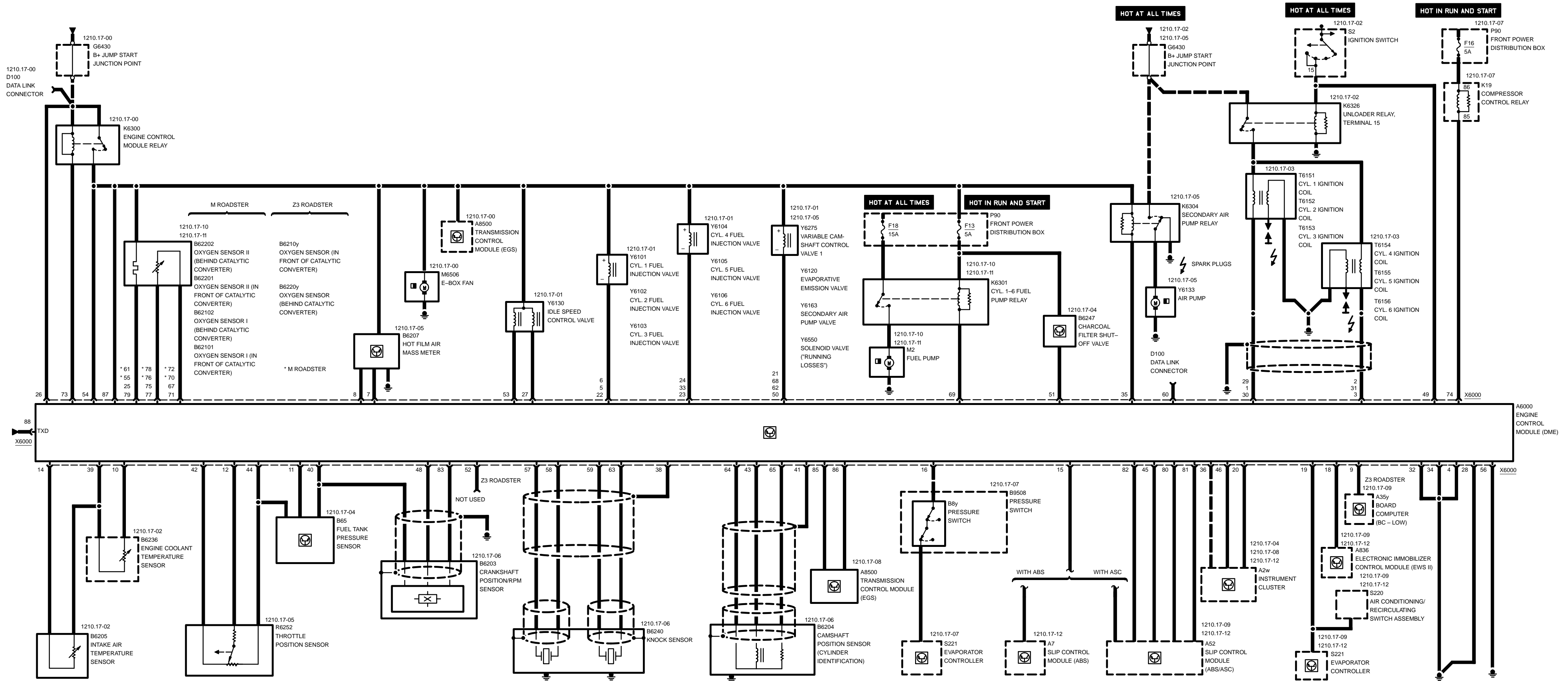

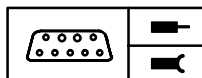

Z3

**Pin Assignments****X6000**

Pin	Type	Description/Function	Connection
1	A	Cyl. 2 ignition coil control	Cyl. 2 ignition coil
2	A	Cyl. 4 ignition coil control	Cyl. 4 ignition coil
3	A	Cyl. 6 ignition coil control	Cyl. 6 ignition coil
4	M	Ground	Ground point
5	A	Cyl. 2 fuel injection valve control	Cyl. 2 fuel injection valve
6	A	Cyl. 1 fuel injection valve control	Cyl. 1 fuel injection valve
7	M	Ground	Hot wire air mass meter
8	E	Hot wire air mass meter	Hot wire air mass meter
9	E	TI-measurement signal (fuel consumption)	Board computer (Z3 Roadster)
10	E	Engine coolant temperature	Engine coolant temperature sensor
11	E	Fuel tank pressure	Fuel tank pressure sensor
12	E	Throttle position signal	Throttle position sensor
13		Not used	
14	E	Intake air temperature	Intake air temperature sensor
15	E	Right rear speed signal	ABS/ASC control module
16	E	Activate A/C	Pressure switch
17		Not used	
18	E	Drive-away protection signal (code)	Electronic immobilizer control module (EWS II)
19	E	A/C-ON-signal	Air conditioning operating unit
20	A	"Check engine" indicator control	Instrument cluster
21	A	Camshaft control	Variable camshaft control valve
22	A	Cyl. 3 fuel injection valve control	Cyl. 3 fuel injection valve
23	A	Cyl. 6 fuel injection valve control	Cyl. 6 fuel injection valve
24	A	Cyl. 4 fuel injection valve control	Cyl. 4 fuel injection valve
25	M	Oxygen sensor heating ground	Oxygen sensor (in front of catalytic converter)
26	E	Battery voltage	B+ jump start junction point
27	A	Activate valve	Idle speed control valve
28	M	Ground	Ground point
29	A	Cyl. 1 ignition coil control	Cyl. 1 ignition coil

E = Input, A = Output, M = Ground



Z3

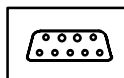

Pin Assignments

Pin	Type	Description/Function	Connection
30	A	Cyl. 3 ignition coil control	Cyl. 3 ignition coil
31	A	Cyl. 5 ignition coil control	Cyl. 5 ignition coil
32	M	Ground	Ground point
33	A	Cyl. 5 fuel injection valve control	Cyl. 5 fuel injection valve
34	M	Ground	Ground point
35	A	Activate relay	Secondary air pump relay
36	A	Crankshaft RPM speed signal TD	Instrument cluster
37		Not used	
38	M	Ground	Shield knock sensor
39	M	Ground	Temperature sensors
40	M	Ground	Crankshaft position/RPM sensor Fuel tank pressure sensor
41	M	Ground	Shield camshaft position sensor
42	M	Ground	Throttle position sensor
43	M	Ground	Camshaft position sensor
44	A	Voltage supply	Throttle position sensor Fuel tank pressure sensor
45	A	Throttle position signal	ABS/ASC control module
46	E	TI-measurement signal (fuel consumption)	Instrument cluster
47		Not used	
48	A	Voltage supply	Crankshaft position/RPM sensor
49	E	Terminal 15	Ignition switch
50	A	Running losses	Solenoid valve
51	A	Activate valve	Charcoal filter shut off valve
52	A	Signal exhaust flap	Not used (Z3 Roadster)
53	A	Activate valve	Idle speed control valve
54	E	Battery voltage, terminal 87	Engine control module relay
55	M	Oxygen sensor heating ground	Oxygen sensor II (in front of catalytic converter) (M Roadster)
56	M	Ground	Ground point
57	E	Cyl. 1-3 knock sensor	Knock sensor
58	E	Cyl. 1-3 knock sensor	Knock sensor
59	E	Cyl. 4-6 knock sensor	Knock sensor

E = Input, A = Output, M = Ground



Z3

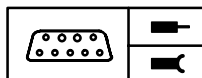

Pin Assignments

Pin	Type	Description/Function	Connection
60	E	Programming voltage	Data link connector
61	M	Oxygen sensor heating ground	Oxygen sensor II (behind catalytic converter) (M Roadster)
62	E	Activate valve	Secondary air pump valve
63	E	Cyl. 4-6 knock sensor	Knock sensor
64	E	Camshaft position	Camshaft position sensor
65	E	Camshaft position	Camshaft position sensor
66		Not used	
67	M	Oxygen sensor signal ground	Oxygen sensor (in front of catalytic converter)
68	E	Activate valve	Evaporative emission valve
69	E	Activate relay	Fuel pump relay
70	M	Oxygen sensor signal ground	Oxygen sensor II (in front of catalytic converter) (M Roadster)
71	M	Oxygen sensor signal ground	Oxygen sensor (behind catalytic converter)
72	M	Oxygen sensor signal ground	Oxygen sensor II (behind catalytic converter) (M Roadster)
73	E	Activate relay	Engine control module relay
74	A	Activate A/C compressor	Compressor control relay
75	E	Sensor signal	Oxygen sensor (in front of catalytic converter)
76	E	Sensor signal	Oxygen sensor II (in front of catalytic converter) (M Roadster)
77	E	Sensor signal	Oxygen sensor (behind catalytic converter)
78	E	Sensor signal	Oxygen sensor II (behind catalytic converter) (M Roadster)
79	M	Oxygen sensor heating ground	Oxygen sensor (behind catalytic converter)
80	A	ASC signal ZA	Slip control module (ABS/ASC)
81	A	ASC signal ZWV	Slip control module (ABS/ASC)
82	A	ASC signal MSR	Slip control module (ABS/ASC)
83	E	Sensor signal	Crankshaft position/RPM sensor
84		Not used	
85	E/A	CAN-LOW	Transmission control module (EGS)
86	E/A	CAN-HIGH	Transmission control module (EGS)

E = Input, A = Output, M = Ground



04/99

1210.17-d

1998

Z3

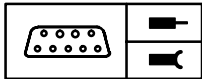

Pin Assignments

Pin	Type	Description/Function	Connection
87	E	Battery voltage, terminal 87	Engine control module relay
88	E/A	TxD diagnosis data link	Data link connector

E = Input, A = Output, M = Ground



ENGINE CONTROL SYSTEM MS41.1 (6-CYLINDER M52/S52)

POWER

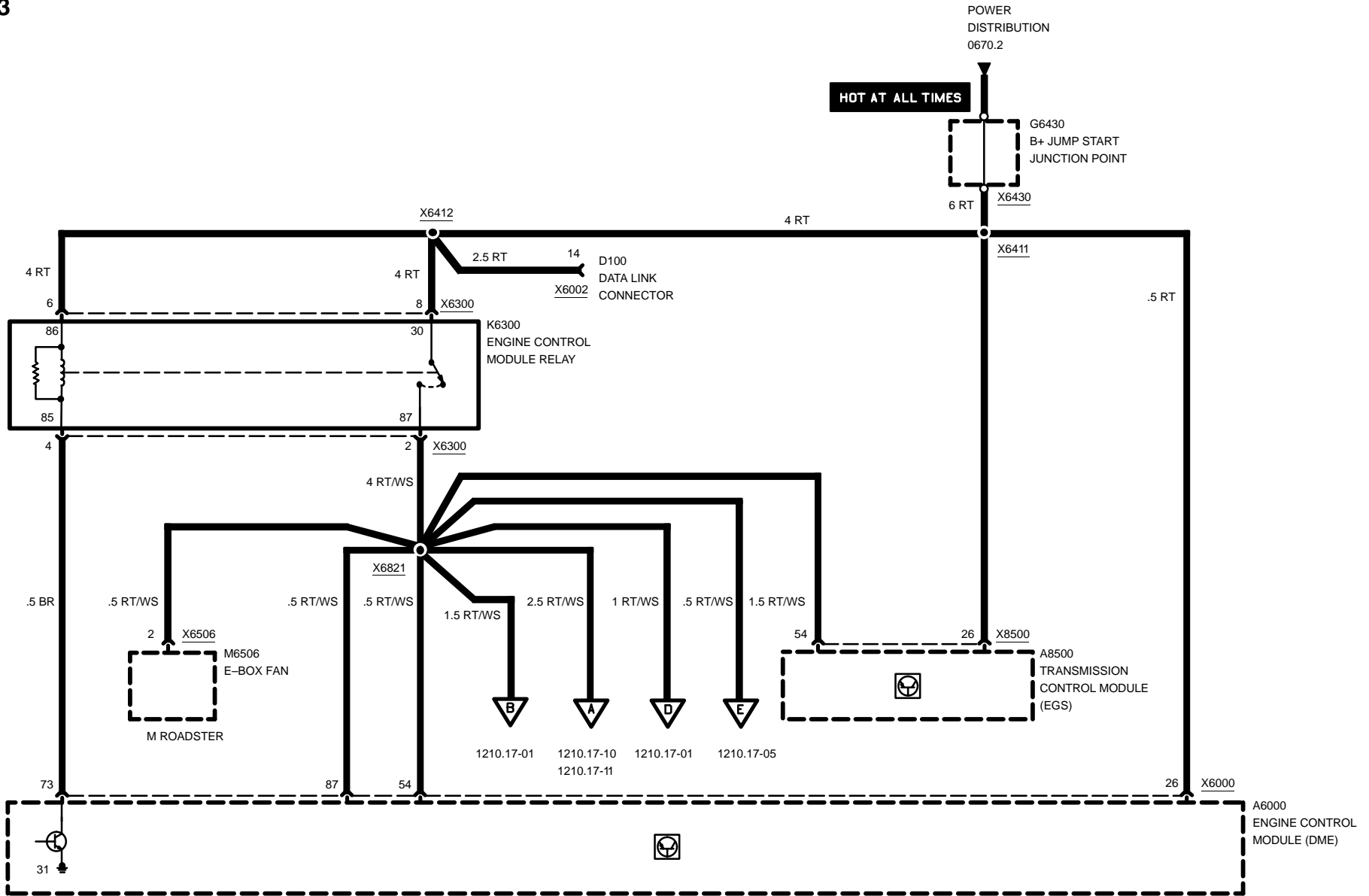



ENGINE CONTROL SYSTEM MS41.1 (6-CYLINDER M52/S52)

Z3

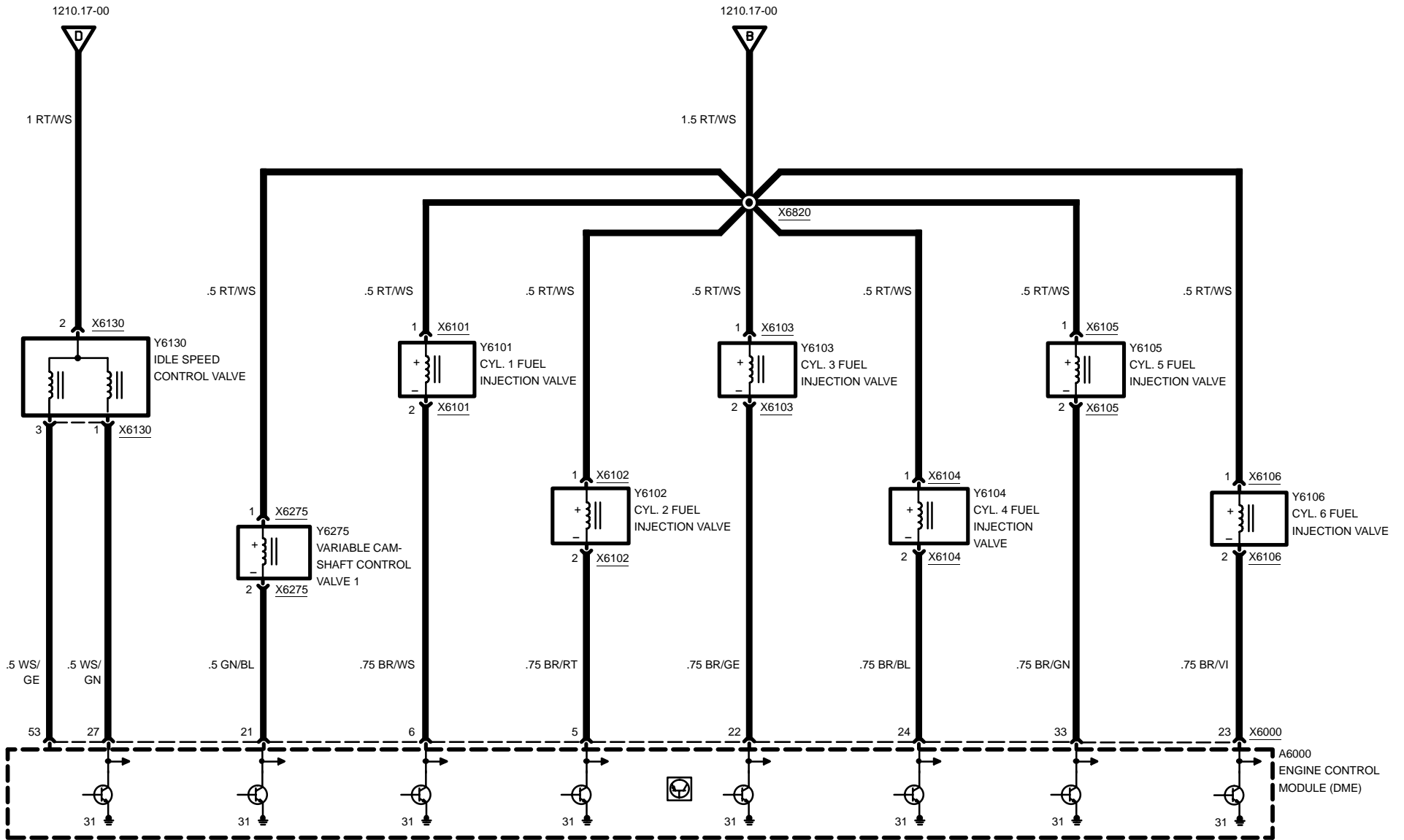



ENGINE CONTROL SYSTEM MS41.1 (6-CYLINDER M52/S52)

Z3

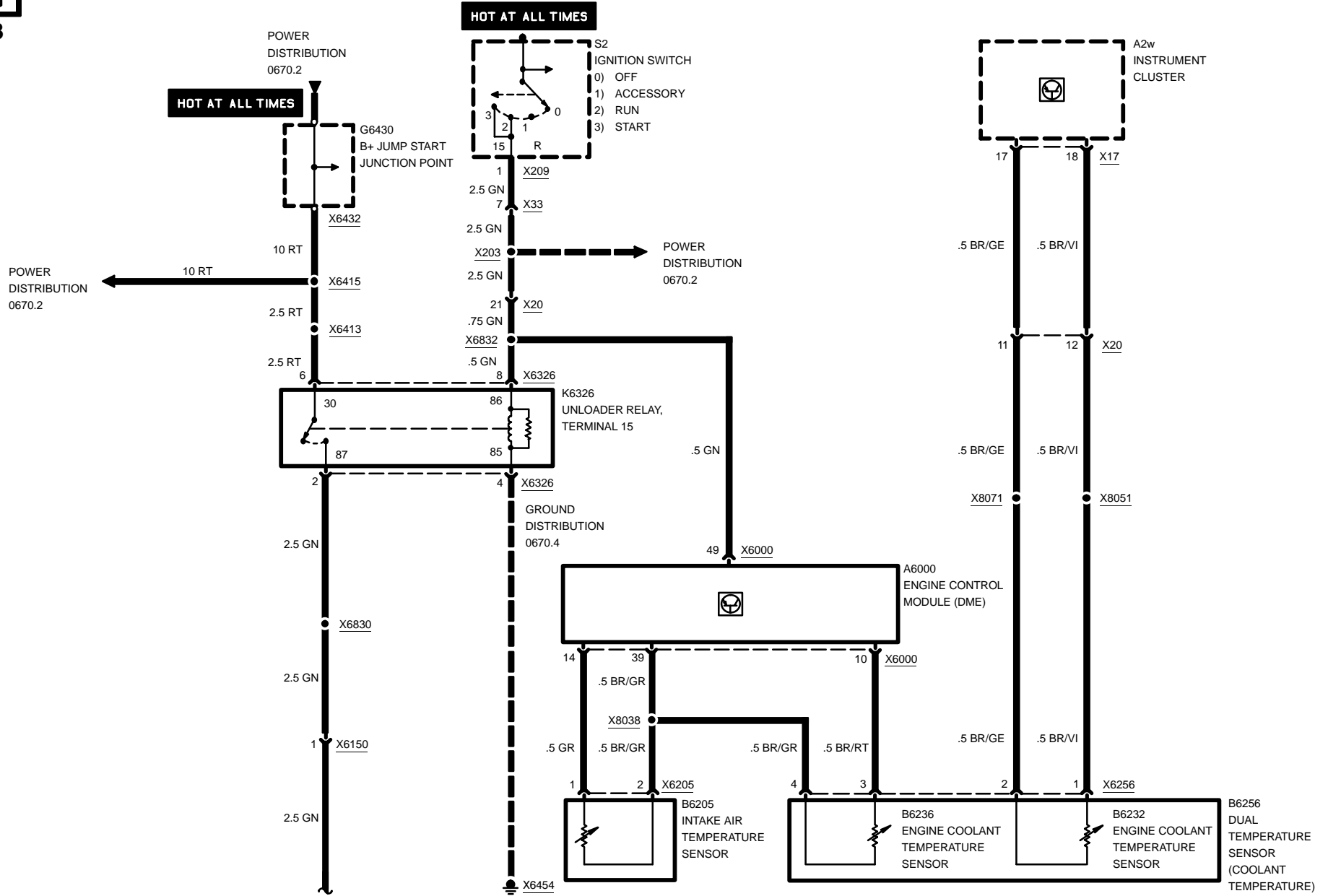

04/99

1210.17-02

1998

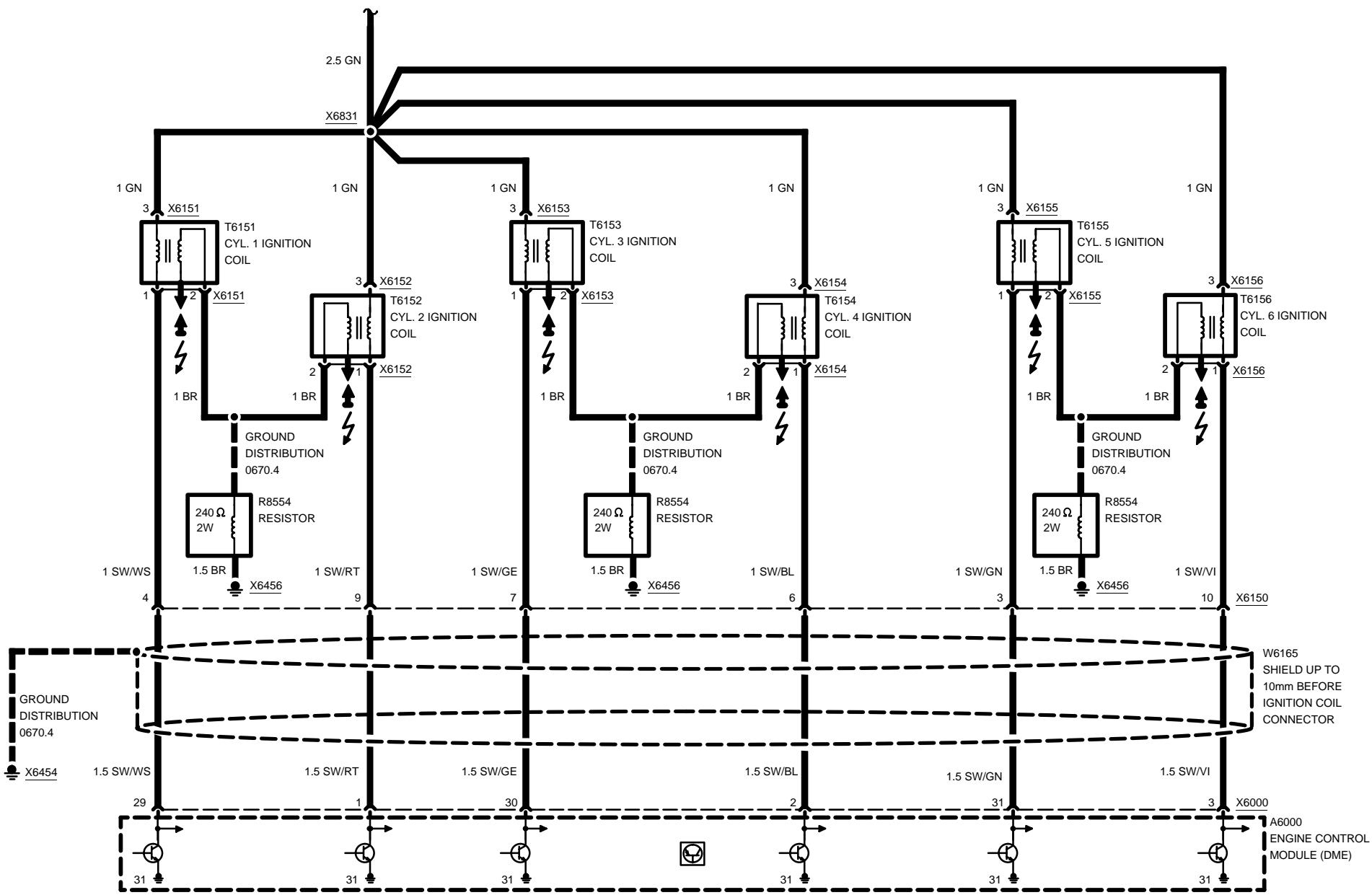



ENGINE CONTROL SYSTEM MS41.1 (6-CYLINDER M52/S52)

OBD II DIAGNOSIS

HOT IN ACCY RUN AND START

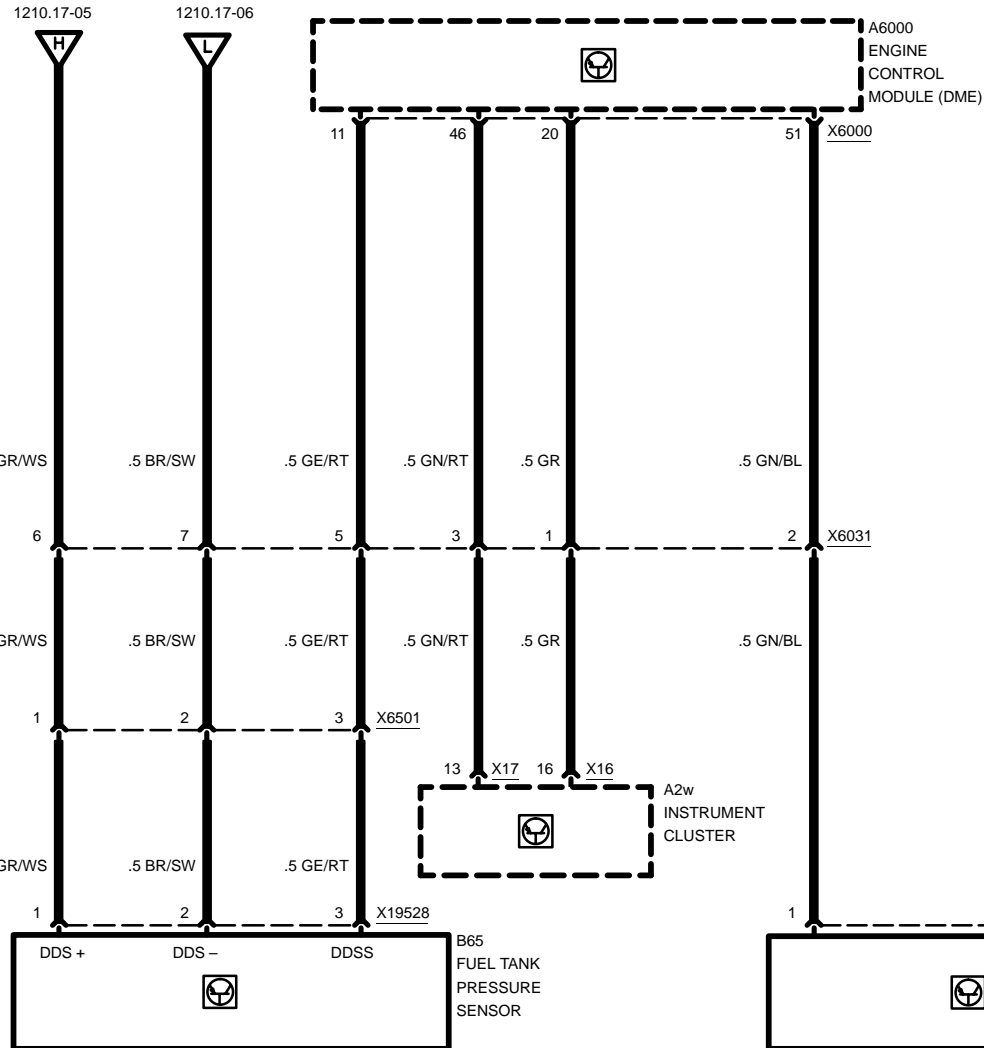
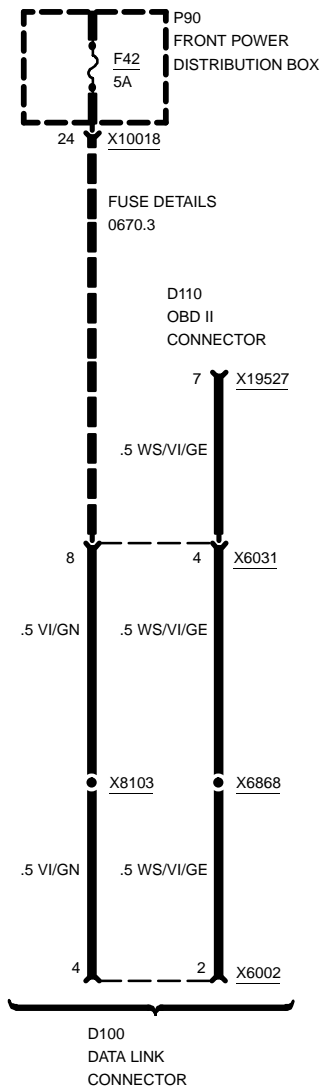

04/99

1210.17-04

1998

ENGINE CONTROL SYSTEM MS41.1 (6-CYLINDER M52/S52)

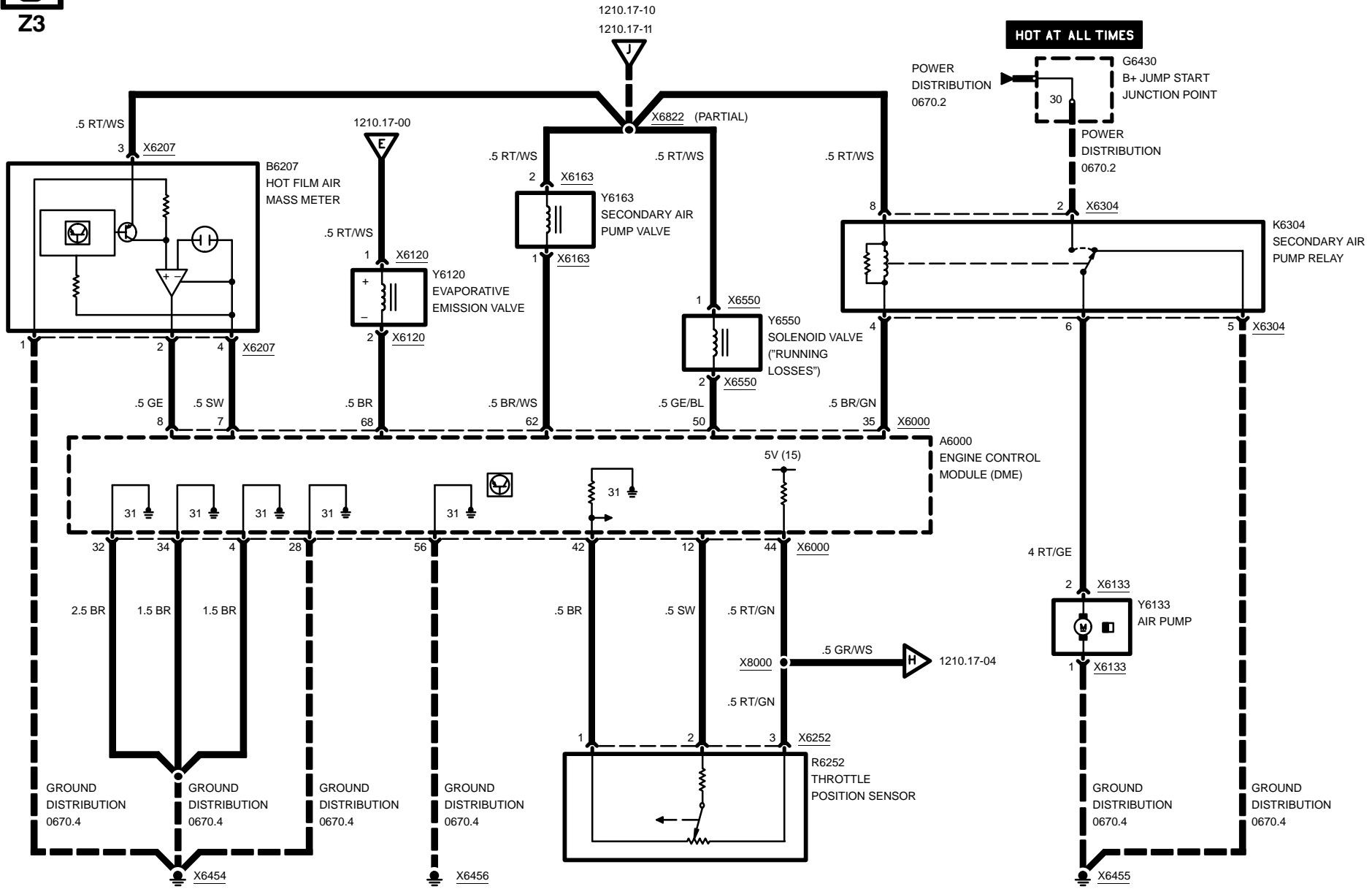

04/99
1210.17-05
1998

ENGINE CONTROL SYSTEM MS41.1 (6-CYLINDER M52/S52)

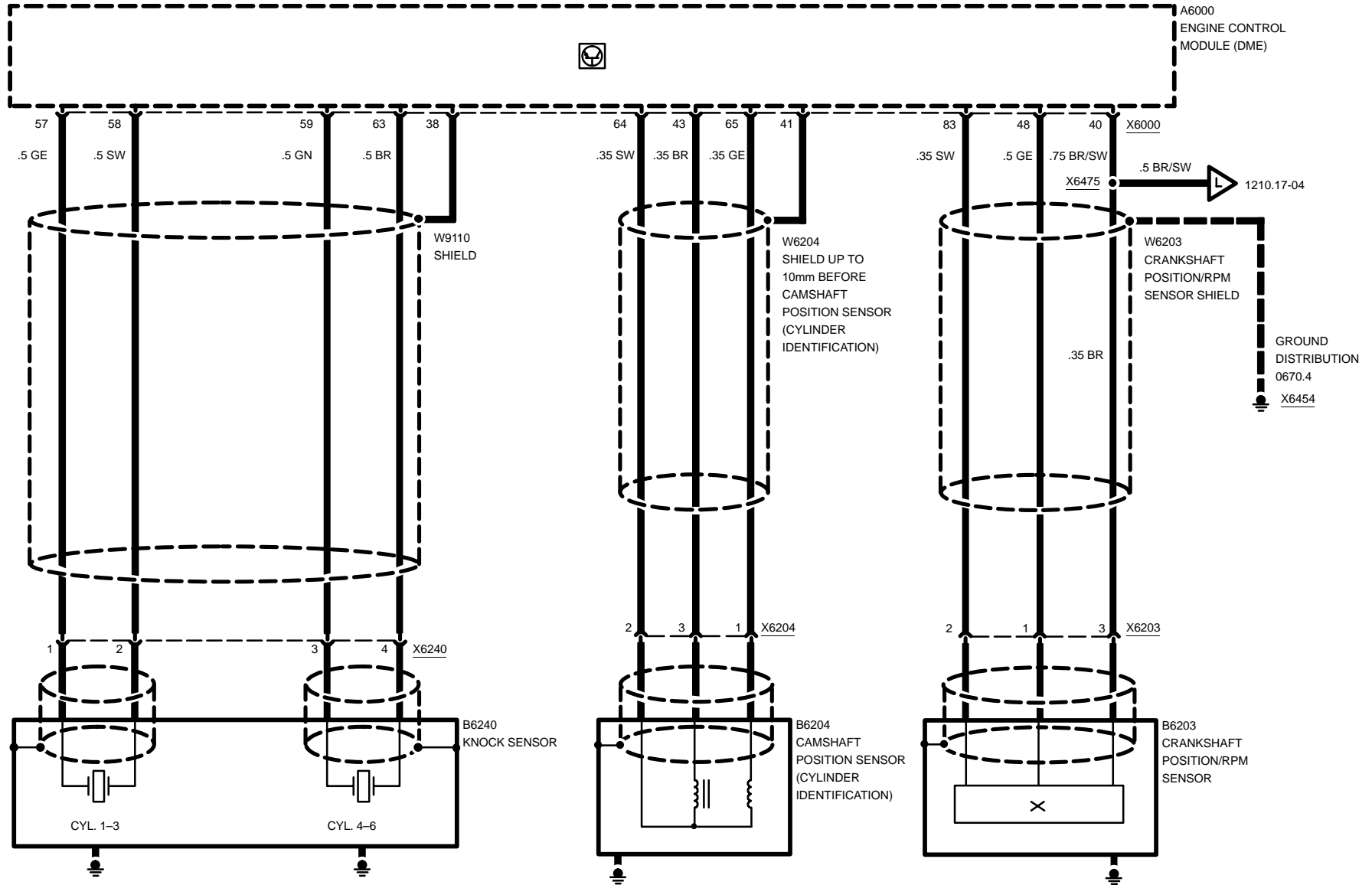



Z3

ENGINE CONTROL SYSTEM MS41.1 (6-CYLINDER M52/S52)

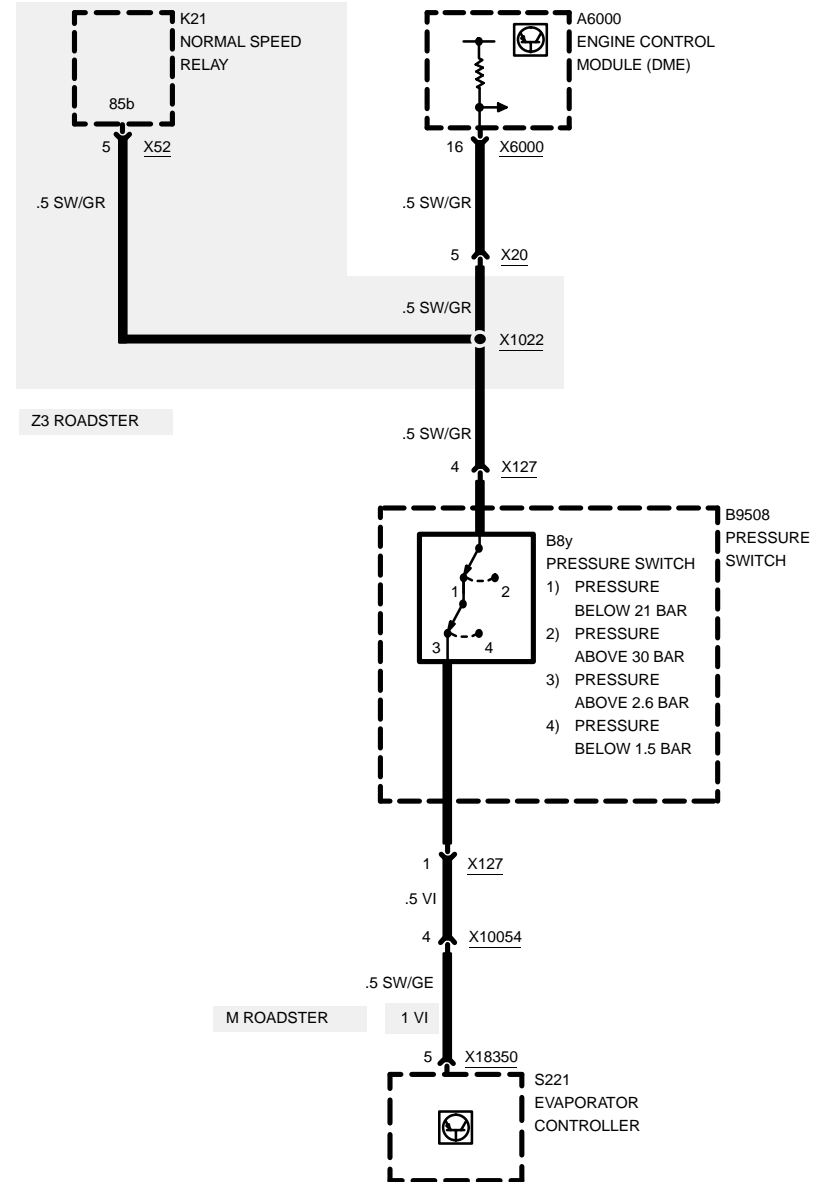
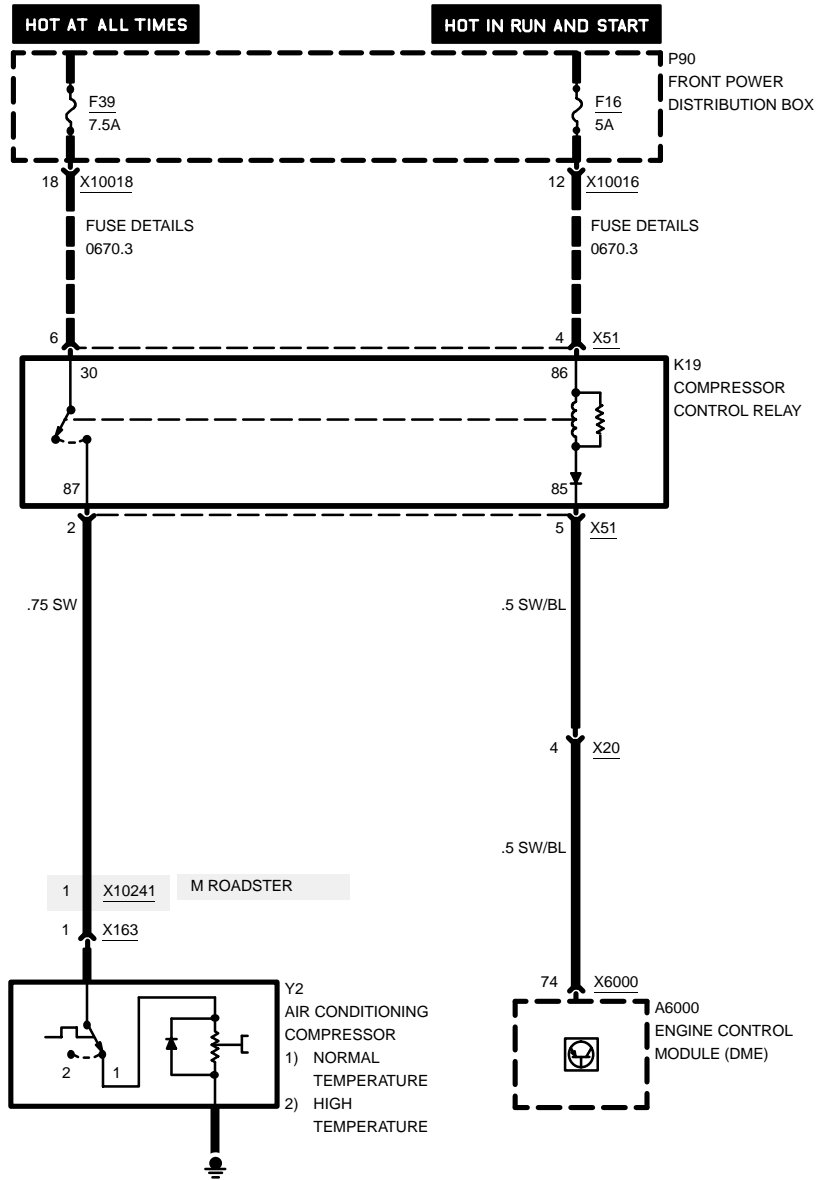

04/99

1210.17-07

1998



ENGINE CONTROL SYSTEM MS41.1 (6-CYLINDER M52)

Z3 ROADSTER

Z3

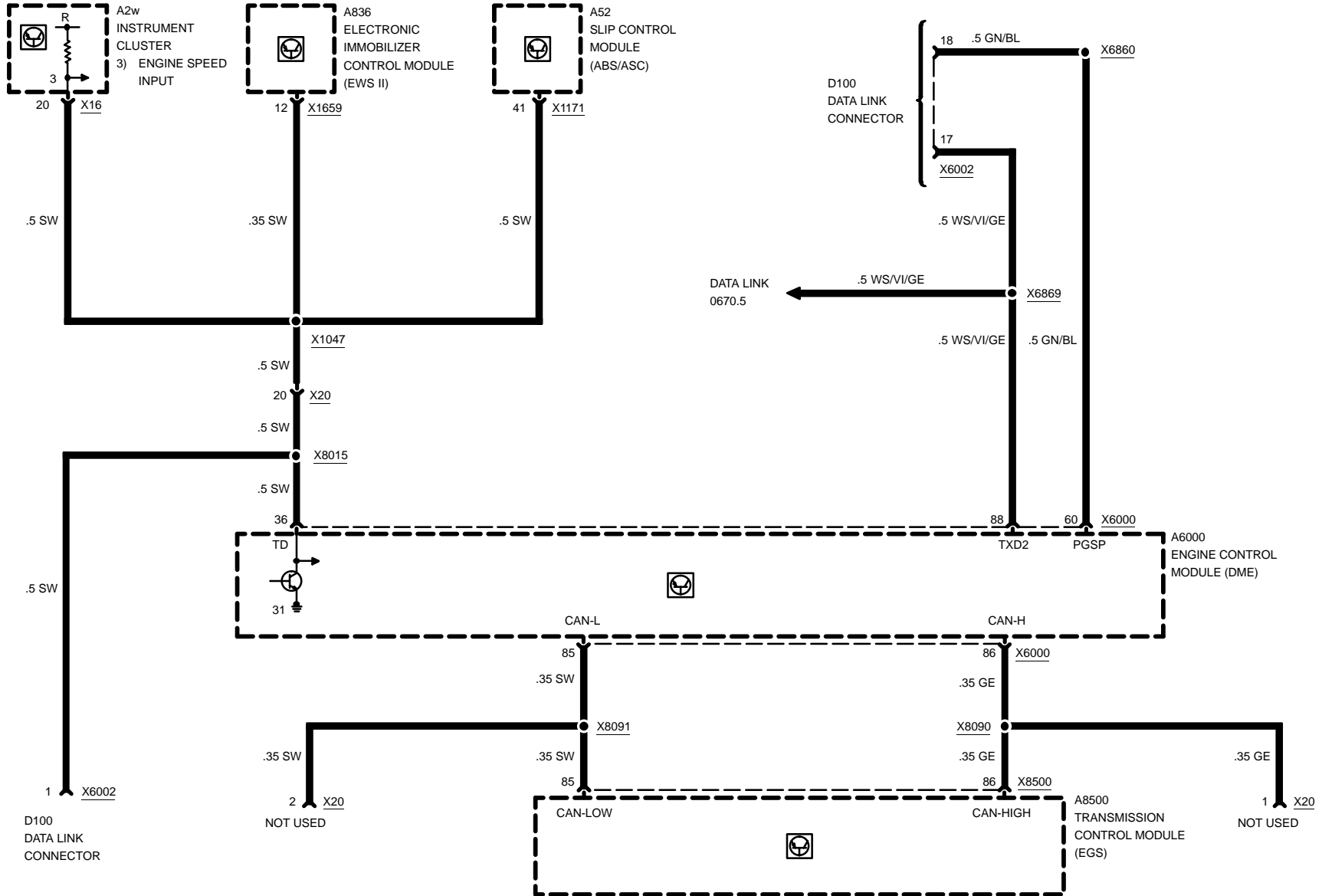

04/99

1210.17-08

1998



ENGINE CONTROL SYSTEM MS41.1 (6-CYLINDER M52)

Z3 ROADSTER

Z3

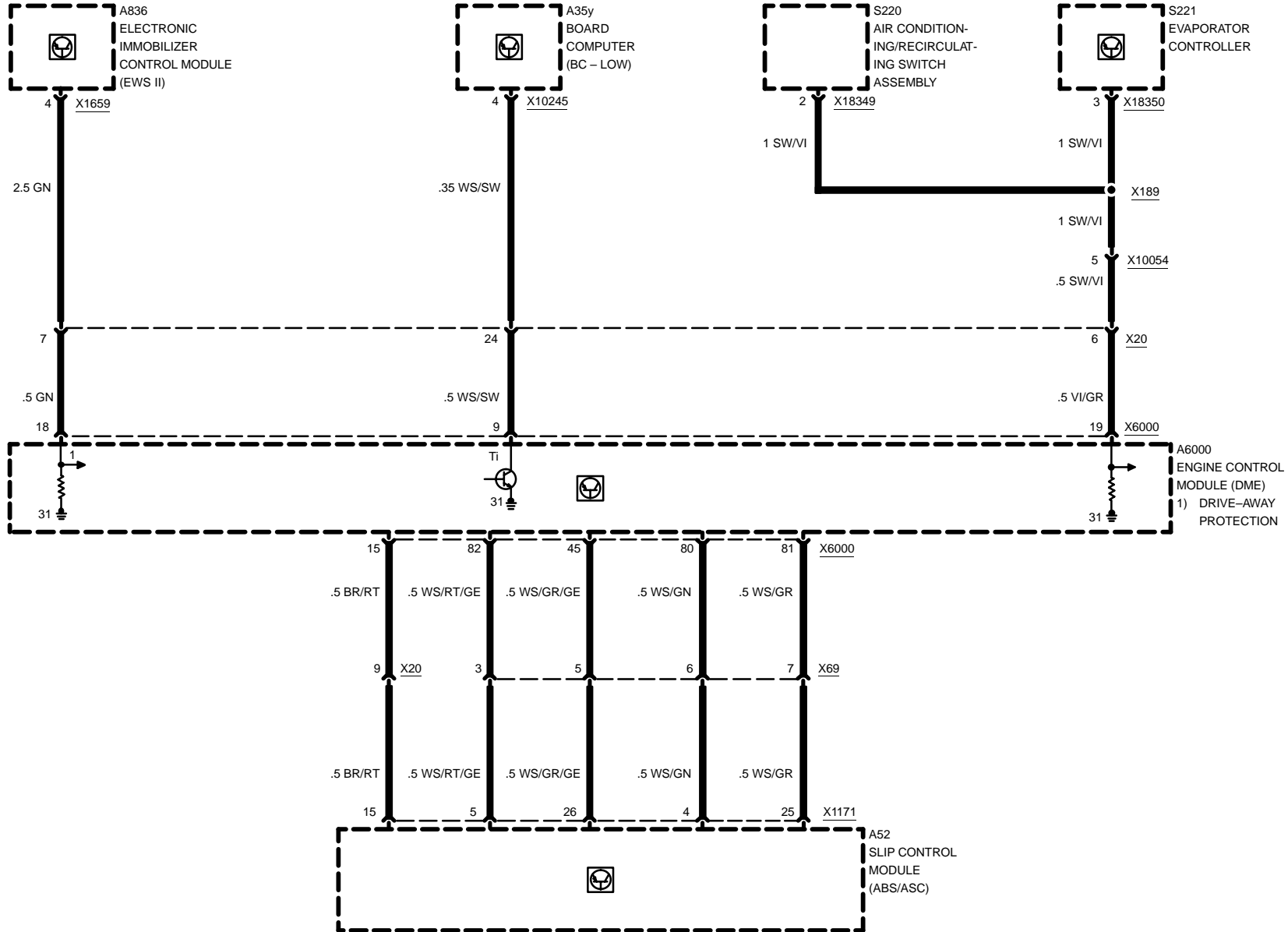

04/99

1210.17-09

1998

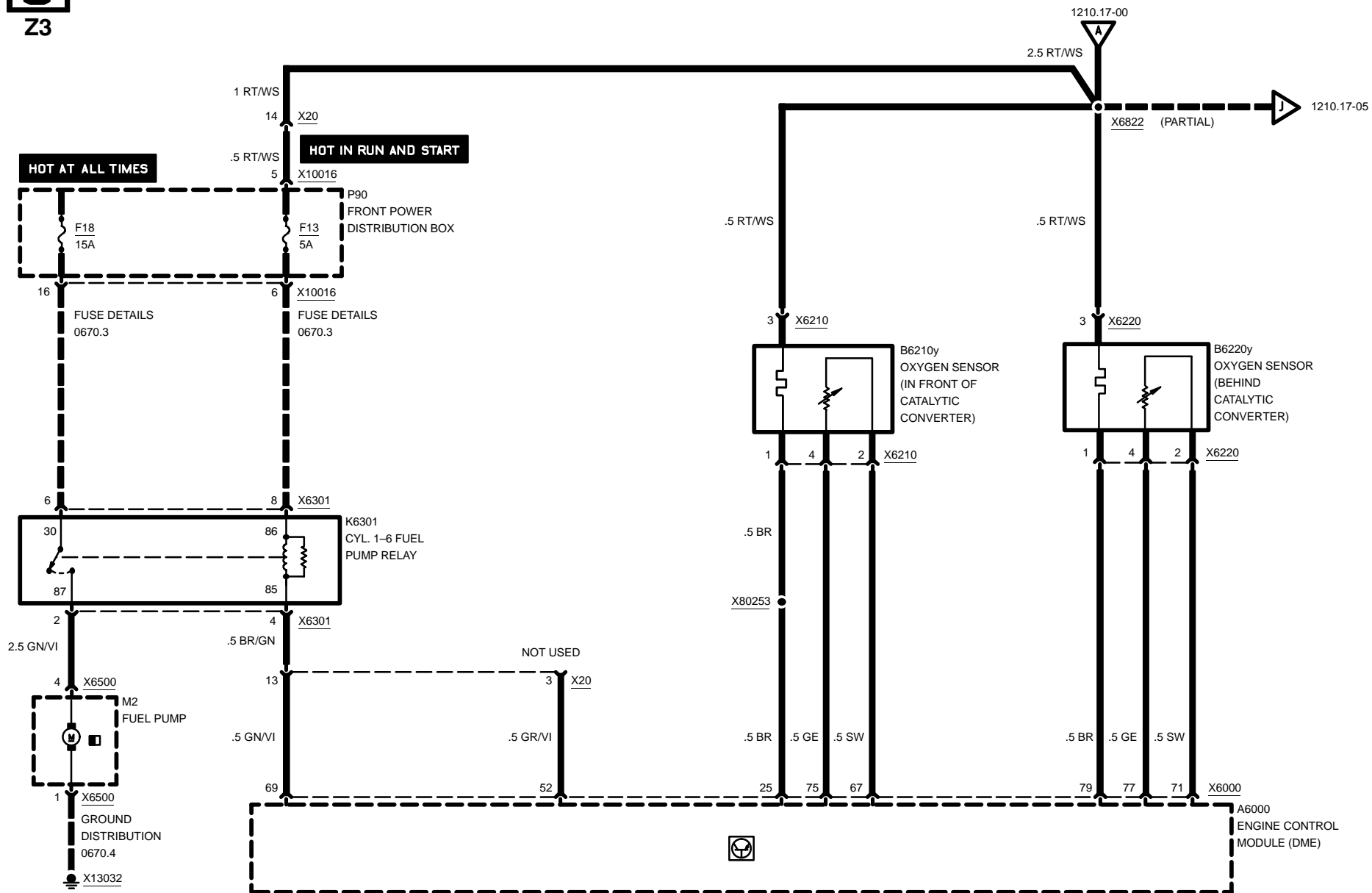

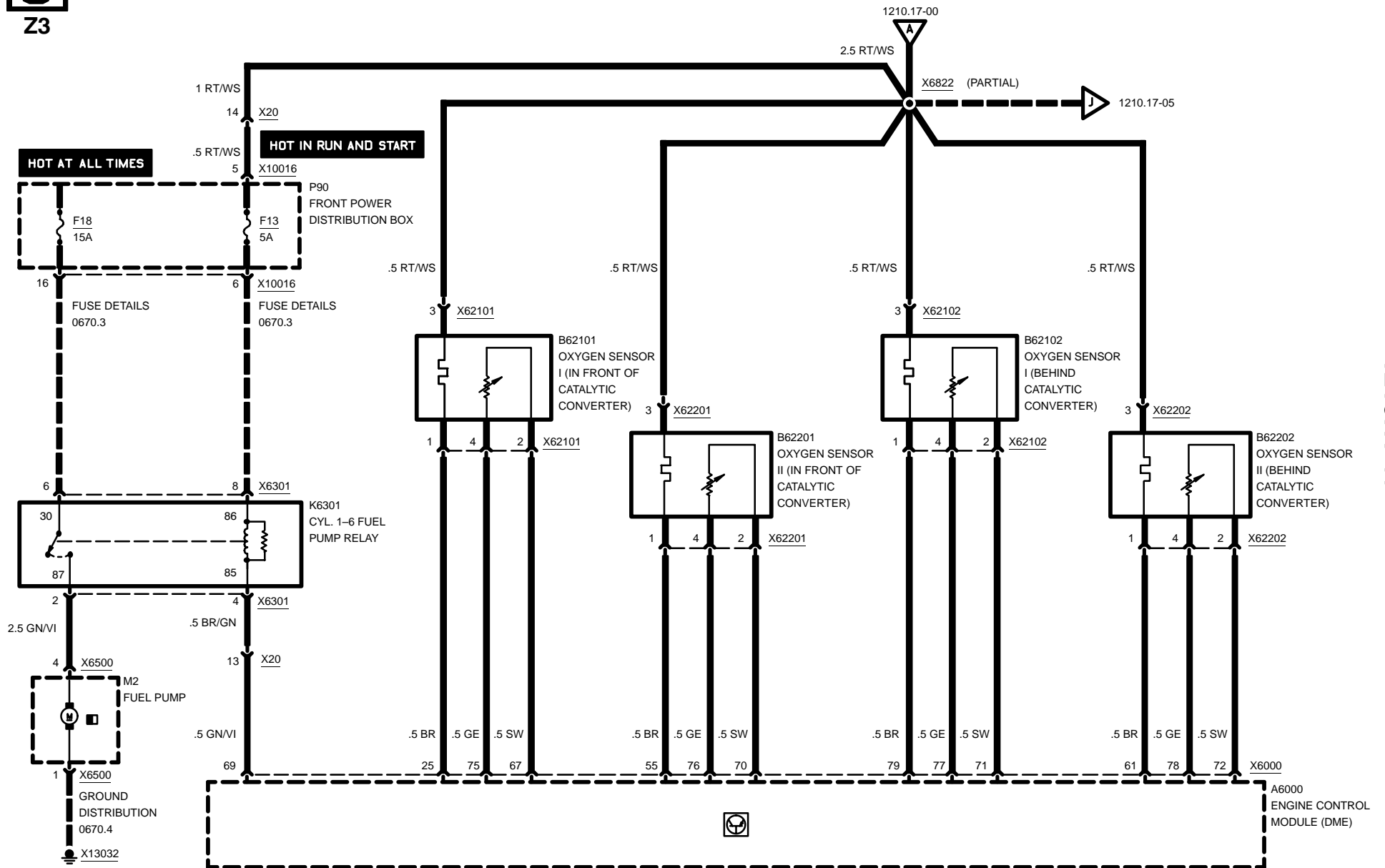

1210.20 ENGINE CONTROL SYSTEM (DME M5.2, 4-CYLINDER M44)

04/99

1210.20

1998

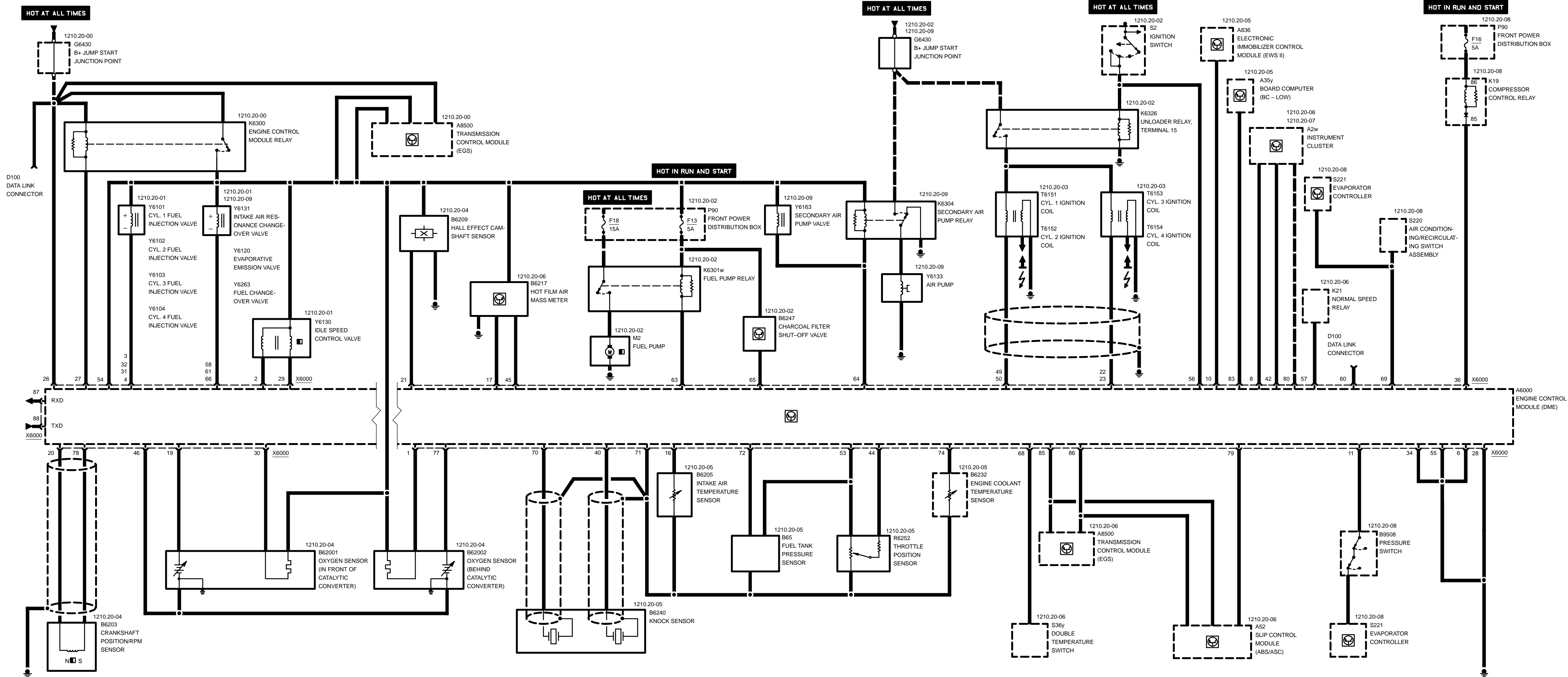

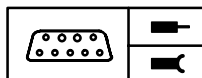

Z3

**Pin Assignments****X6000**

Pin	Type	Description/Function	Connection
89	A	Oxygen sensor heating (-)	Oxygen sensor (behind catalytic converter)
90	A	Activate valve	Idle speed control valve
91	A	Activate valve	Cyl. 1 fuel injection valve
92	A	Activate valve	Cyl. 4 fuel injection valve
93		Not used	
94	M	Ground, fuel injection valve output stages	Ground point
95		Not used	
96	A	"Check engine" indicator control	Instrument cluster
97		Not used	
98	E	Drive-away protection signal	Electronic immobilizer control module (EWS II)
99	E	Activate A/C	Pressure switch
100		Not used	
101		Not used	
102		Not used	
103		Not used	
104	E	Intake air temperature	Intake air temperature sensor
105	M	Ground	Hot film air mass meter
106		Not used	
107	E	Oxygen sensor signal	Oxygen sensor (in front of catalytic converter)
108	E	Crankshaft position/RPM	Crankshaft position/RPM sensor
109	E	Camshaft position	Hall effect camshaft sensor
110	A	Cyl. 3 ignition coil control	Cyl. 3 ignition coil
111	A	Cyl. 4 ignition coil control	Cyl. 4 ignition coil
112		Not used	
113		Not used	
114	E	Battery voltage	B+ jump start junction point
115	A	Engine control module relay control	Engine control module relay, terminal 85
116	M	Ground for electronics and shielding of sensors	Ground point

E = Input, A = Output, M = Ground

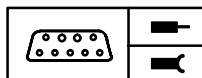

Z3

**Pin Assignments**

Pin	Type	Description/Function	Connection
117	A	Idle speed control valve control	Idle speed control valve
118	A	Oxygen sensor heating	Oxygen sensor (in front of catalytic converter)
119	A	Activate valve	Cyl. 3 fuel injection valve
120	A	Activate valve	Cyl. 2 fuel injection valve
121		Not used	
122	M	Ground, remaining output stages (except for ignition and fuel injection valves)	Ground point
123		Not used	
124	A	A/C compressor cut-out	Compressor control relay
125		Not used	
126		Not used	
127		Not used	
128	E	Cyl. 3-4 knock sensor	Knock sensor
129		Not used	
130	E	TI-measurement signal (fuel consumption)	Instrument cluster
131		Not used	
132	E	Throttle position	Throttle position sensor
133	E	Signal input	Hot film air mass meter
134	M	Sensor ground	Oxygen sensors
135		Not used	
136		Not used	
137	A	Cyl. 1 ignition coil control	Cyl. 1 ignition coil
138	A	Cyl. 2 ignition coil control	Cyl. 2 ignition coil
139		Not used	
140		Not used	
141	A	Component supply (+)	Throttle position sensor/fuel tank pressure sensors
142	E	Battery voltage from engine control module relay	Engine control module relay, terminal 87
143	M	Ground, ignition	Ground point
144	E	Ignition switch, terminal 15	Ignition switch, terminal 15
145	A	Activate auxiliary fan	Normal speed relay

E = Input, A = Output, M = Ground



Z3

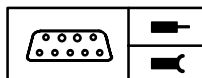

Pin Assignments

Pin	Type	Description/Function	Connection
146	A	Activate valve	Intake air resonance changeover valve
147		Not used	
148	E	Programming voltage	Data link connector
149	A	Activate valve	Evaporation emission valve
150		Not used	
151	A	Activate relay	Fuel pump relay
152	A	Activate air pump	Secondary air pump valve/relay
153	A	Activate valve	Charcoal filter shut-off valve
154	A	Activate valve	Fuel changeover valve
155		Not used	
156	E	Signal above 80 °C	Double temperature switch
157	E	A/C-ON-signal	Air conditioning operating unit
158	E	Cyl 1-2 knock sensor	Knock sensor
159	M	Ground for sensors	Temperature/knock/throttle position/fuel tank pressure sensors
160	E	Fuel tank pressure	Fuel tank pressure sensor
161		Not used	
162	E	Temperature signal	Engine coolant temperature sensor
163		Not used	
164		Not used	
165	E	Oxygen sensor signal	Oxygen sensor (behind catalytic converter)
166	E	Crankshaft position/RPM	Crankshaft position/RPM sensor
167	E	Right rear speed signal	ABS/ASC control module
168	E	Crankshaft RPM speed signal TD	Instrument cluster
169		Not used	
170		Not used	
171	E	Vehicle speed signal	Board computer (BC-Low)
172		Not used	
173	E/A	CAN-LOW	EGS/ASC control module
174	E/A	CAN-HIGH	EGS/ASC control module
175	A	RxD diagnosis data line	Data link connector
176	E/A	TxD diagnosis data line	Data link connector

E = Input, A = Output, M = Ground



Z3

ENGINE CONTROL SYSTEM (DME M5.2, 4-CYLINDER M44)

POWER, FUEL INJECTION VALVES

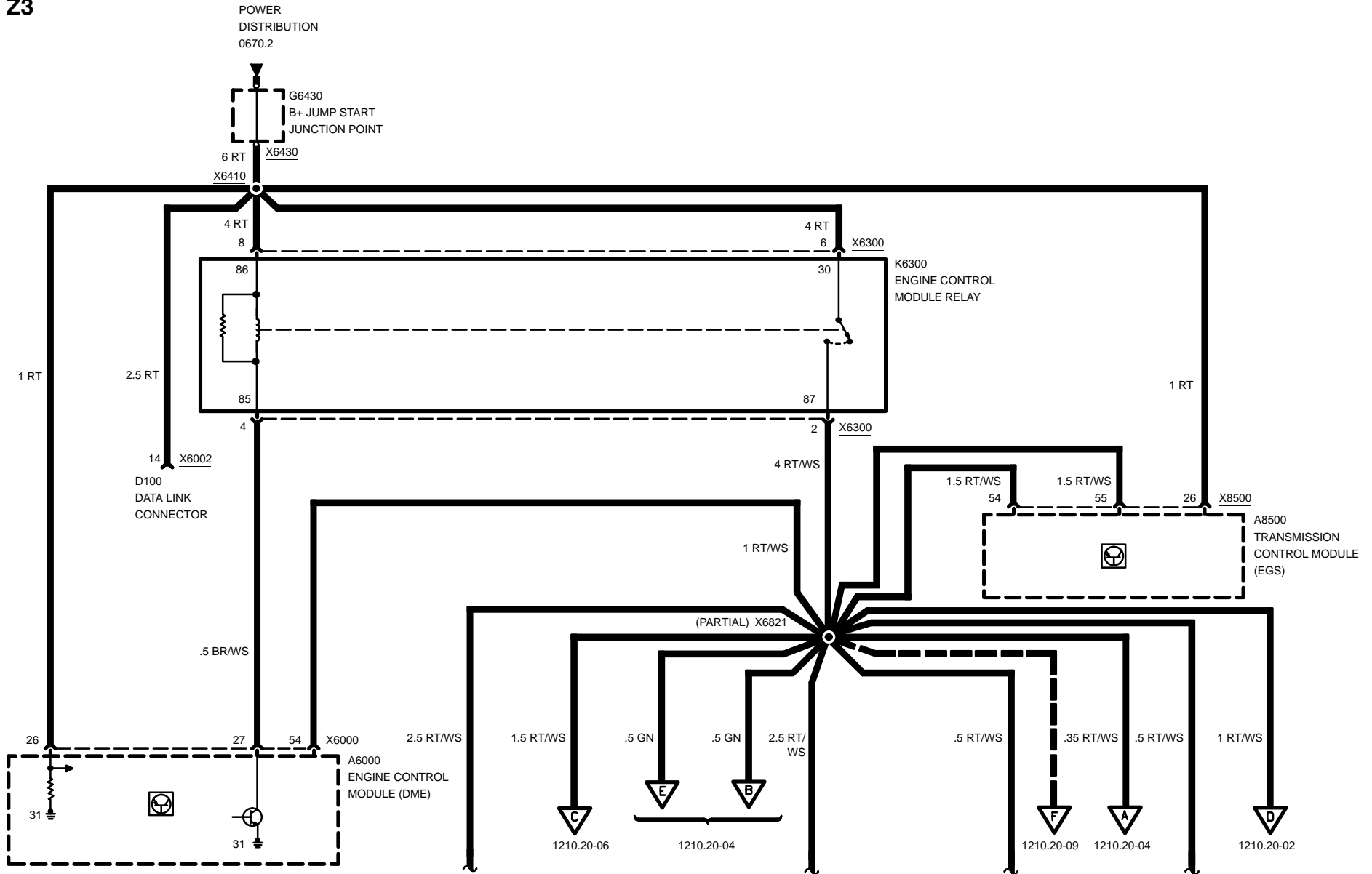

04/99

1210.20-00

1998

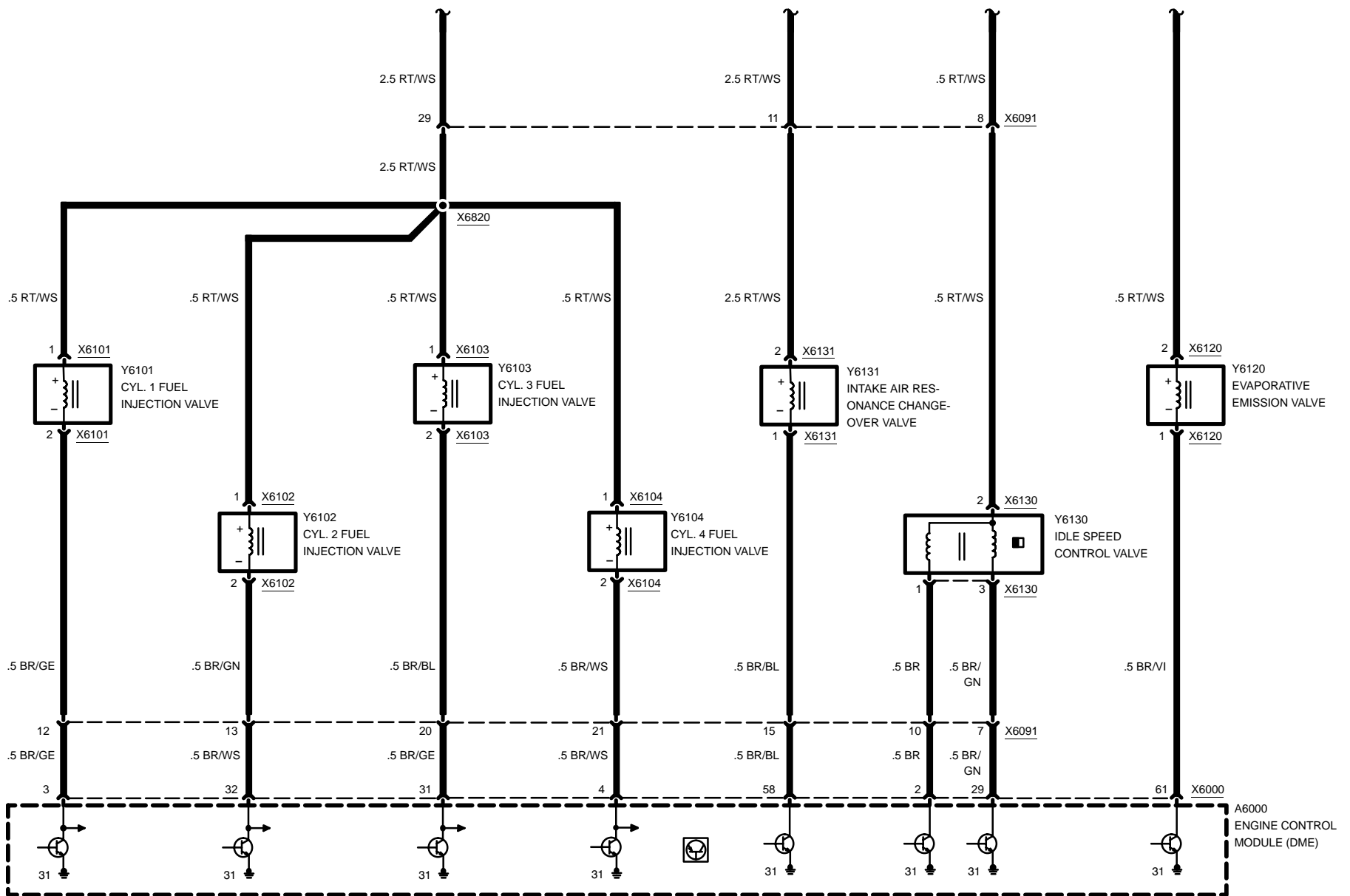



ENGINE CONTROL SYSTEM (DME M5.2, 4-CYLINDER M44)

IGNITION COILS AND FUEL PUMP

Z3

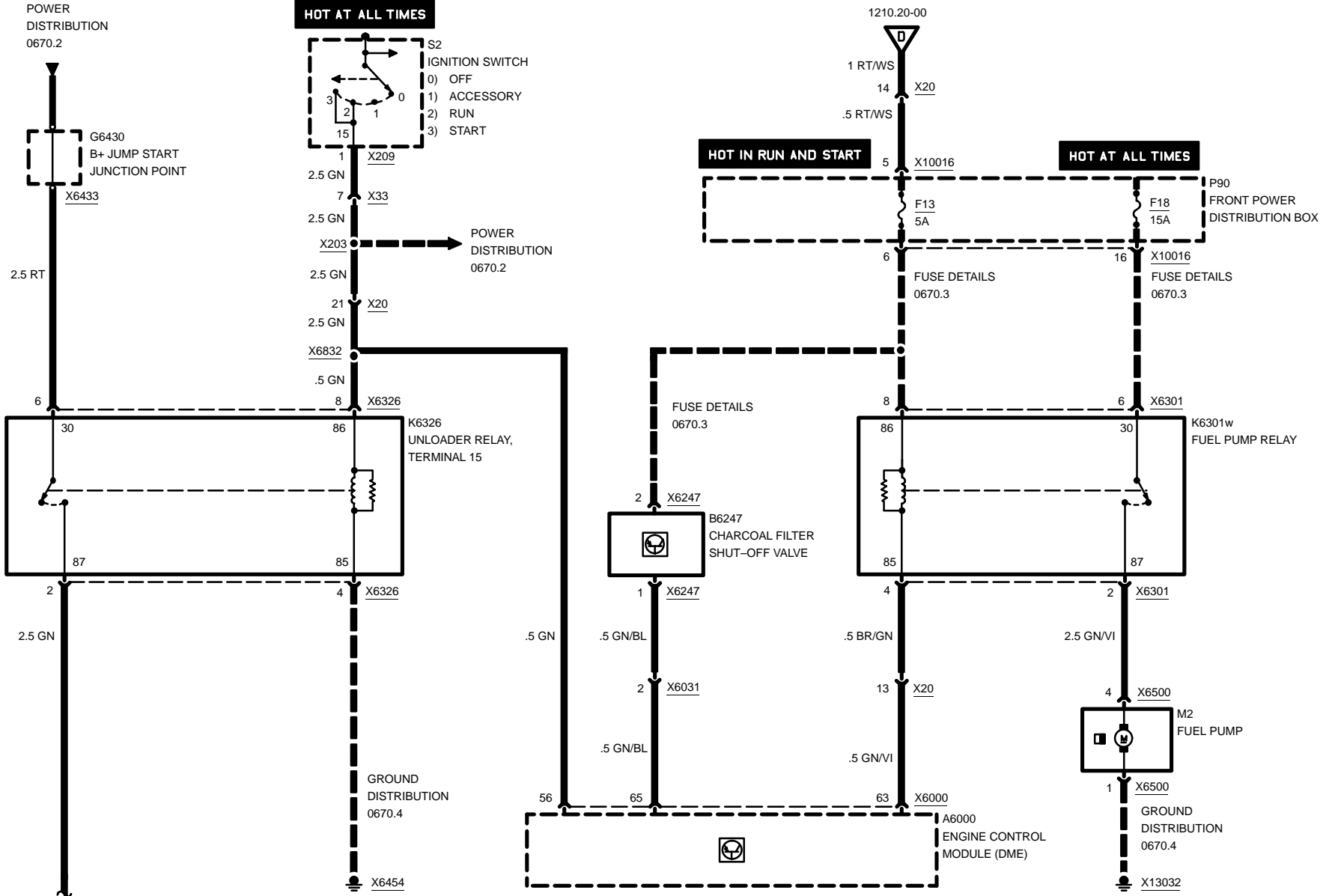

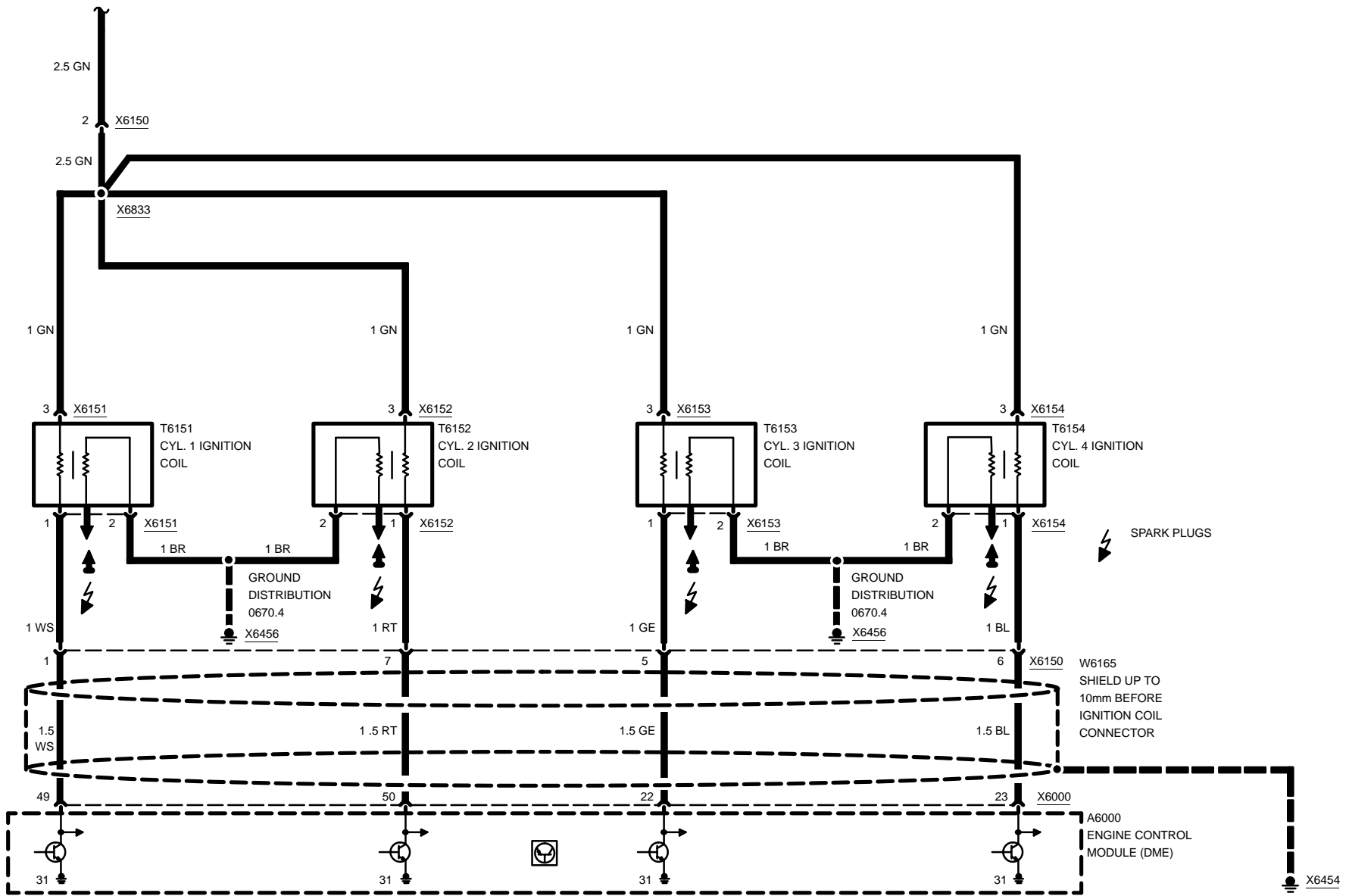



ENGINE CONTROL SYSTEM (DME M5.2, 4-CYLINDER M44)

HEATED OXYGEN SENSOR, CRANKSHAFT SENSORS

Z3

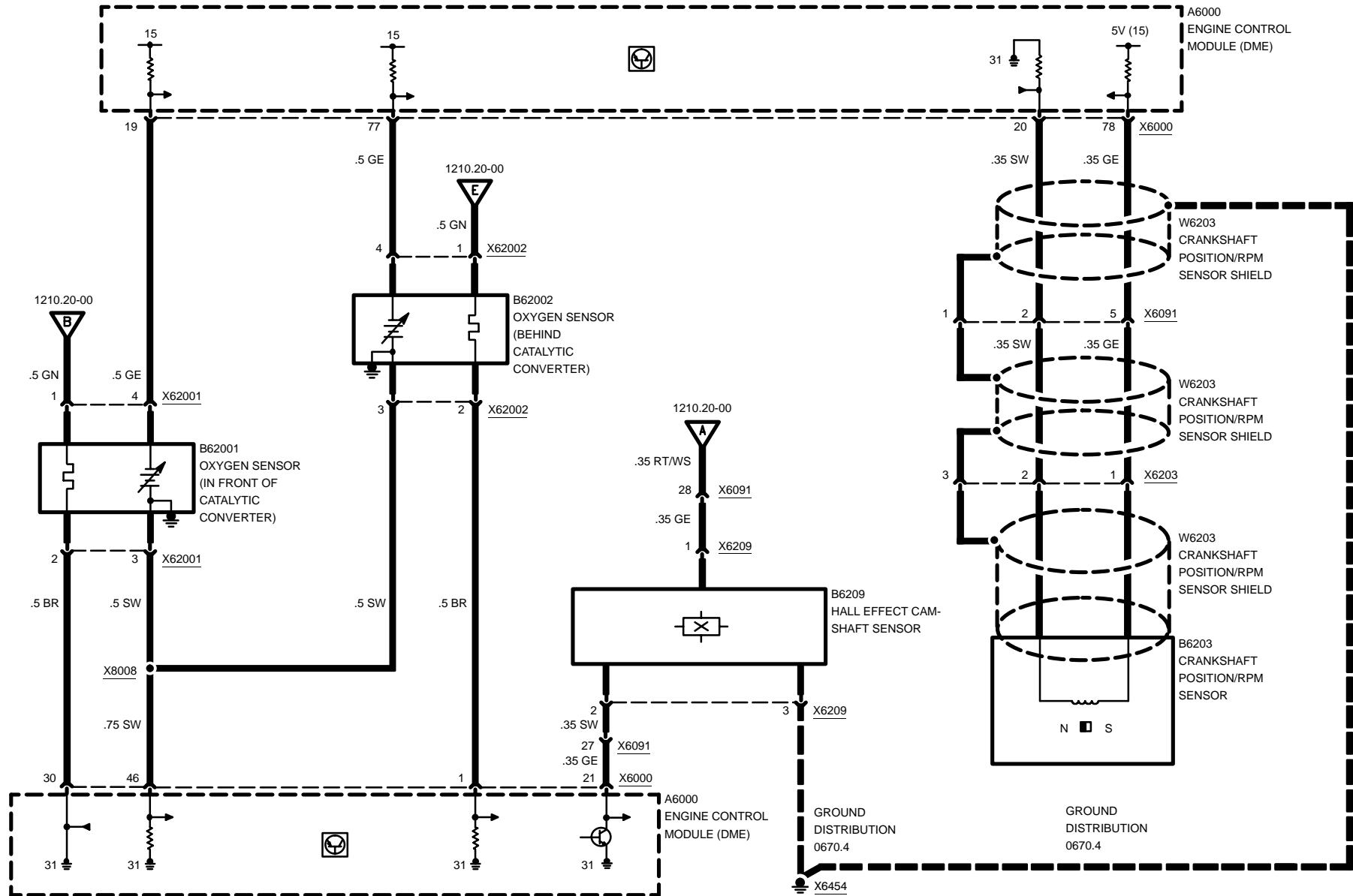

04/99

1210.20-04

1998



Z3

ENGINE CONTROL SYSTEM (DME M5.2, 4-CYLINDER M44)

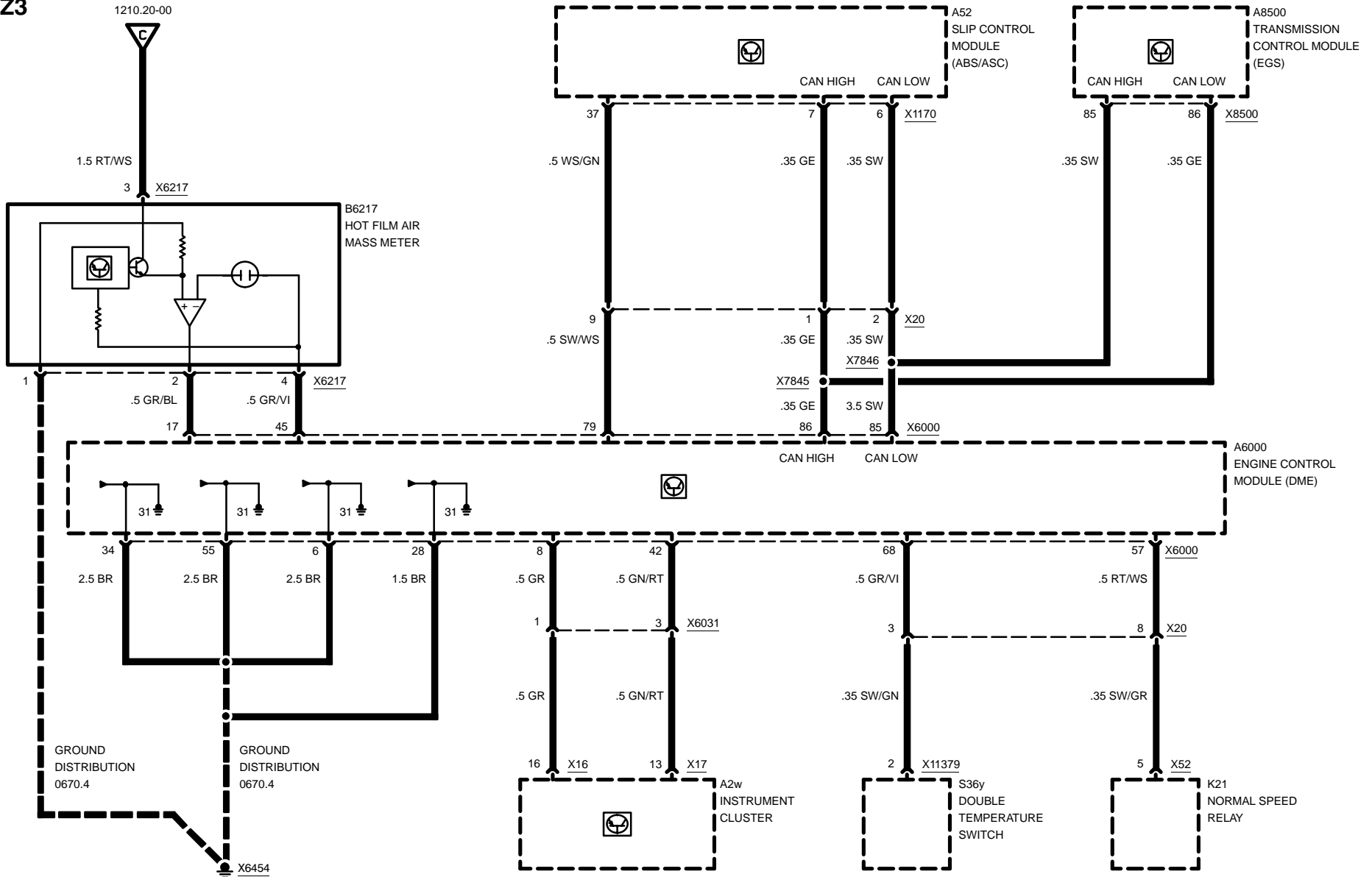

04/99

1210.20-06

1998



ENGINE CONTROL SYSTEM (DME M5.2, 4-CYLINDER M44)

DATA LINK

Z3

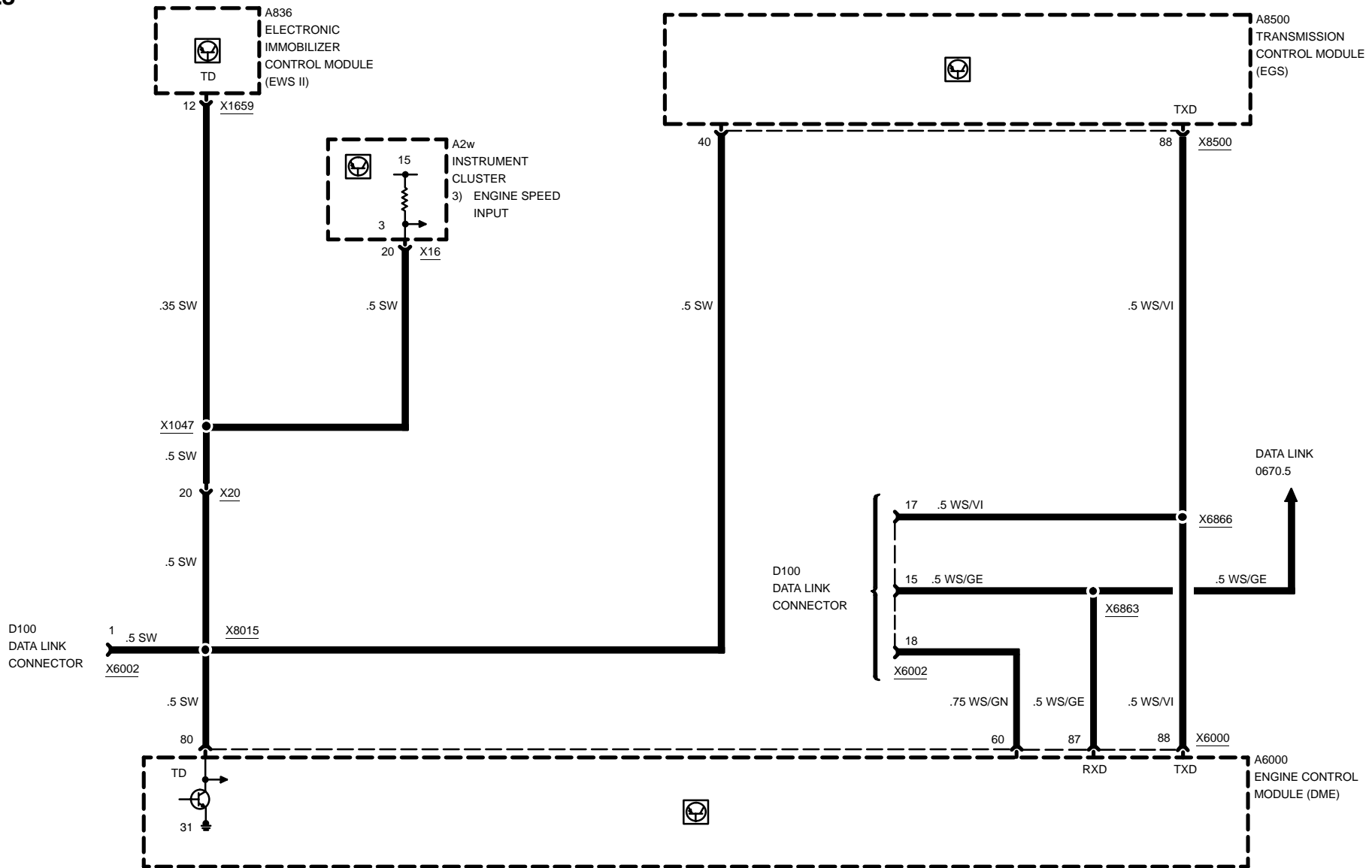

04/99

1210.20-07

1998



ENGINE CONTROL SYSTEM (DME M5.2, 4-CYLINDER M44)

Z3

HOT IN RUN AND START

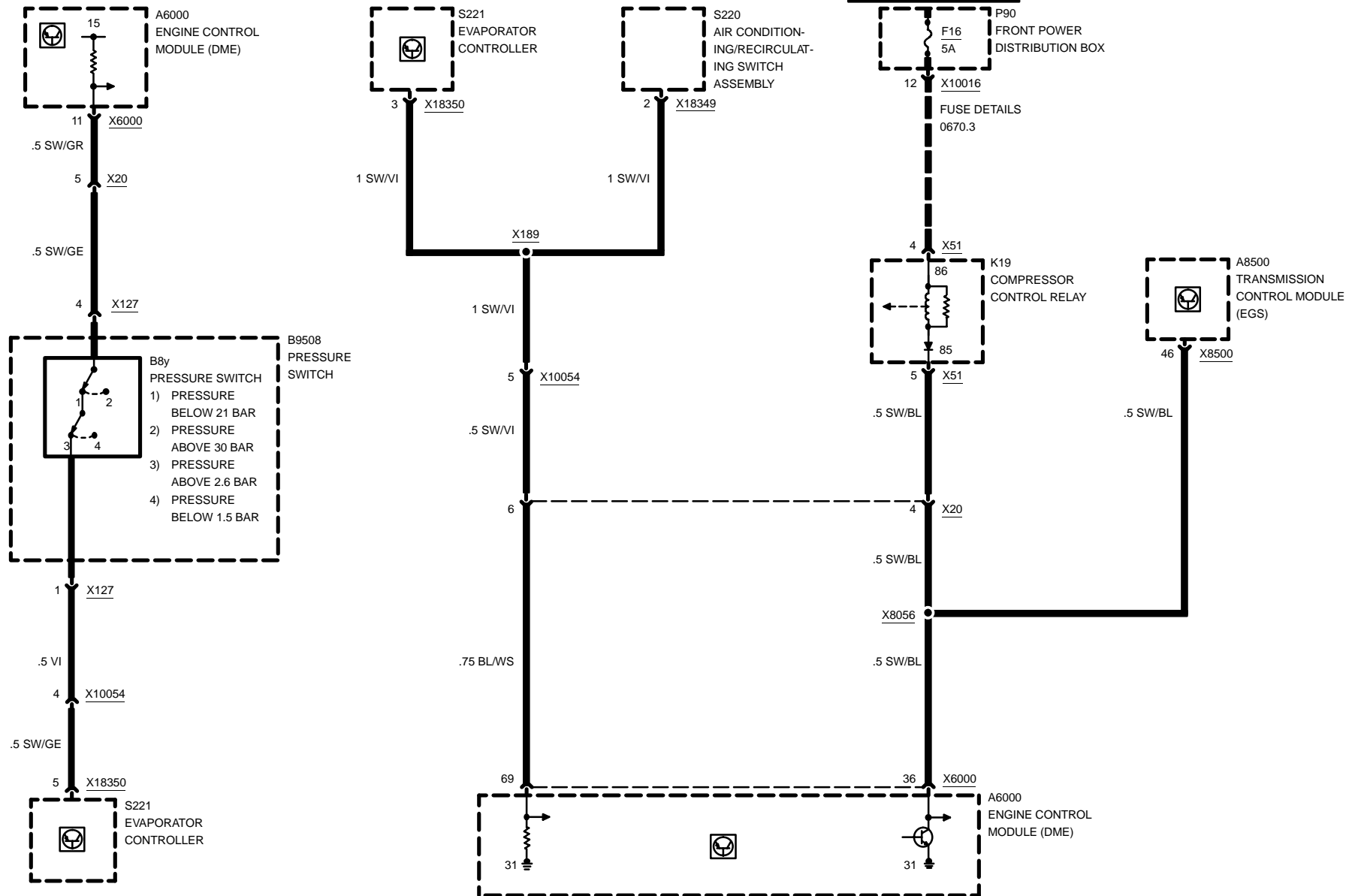

04/99

1210.20-08

1998



ENGINE CONTROL SYSTEM (DME M5.2, 4-CYLINDER M44)

Z3

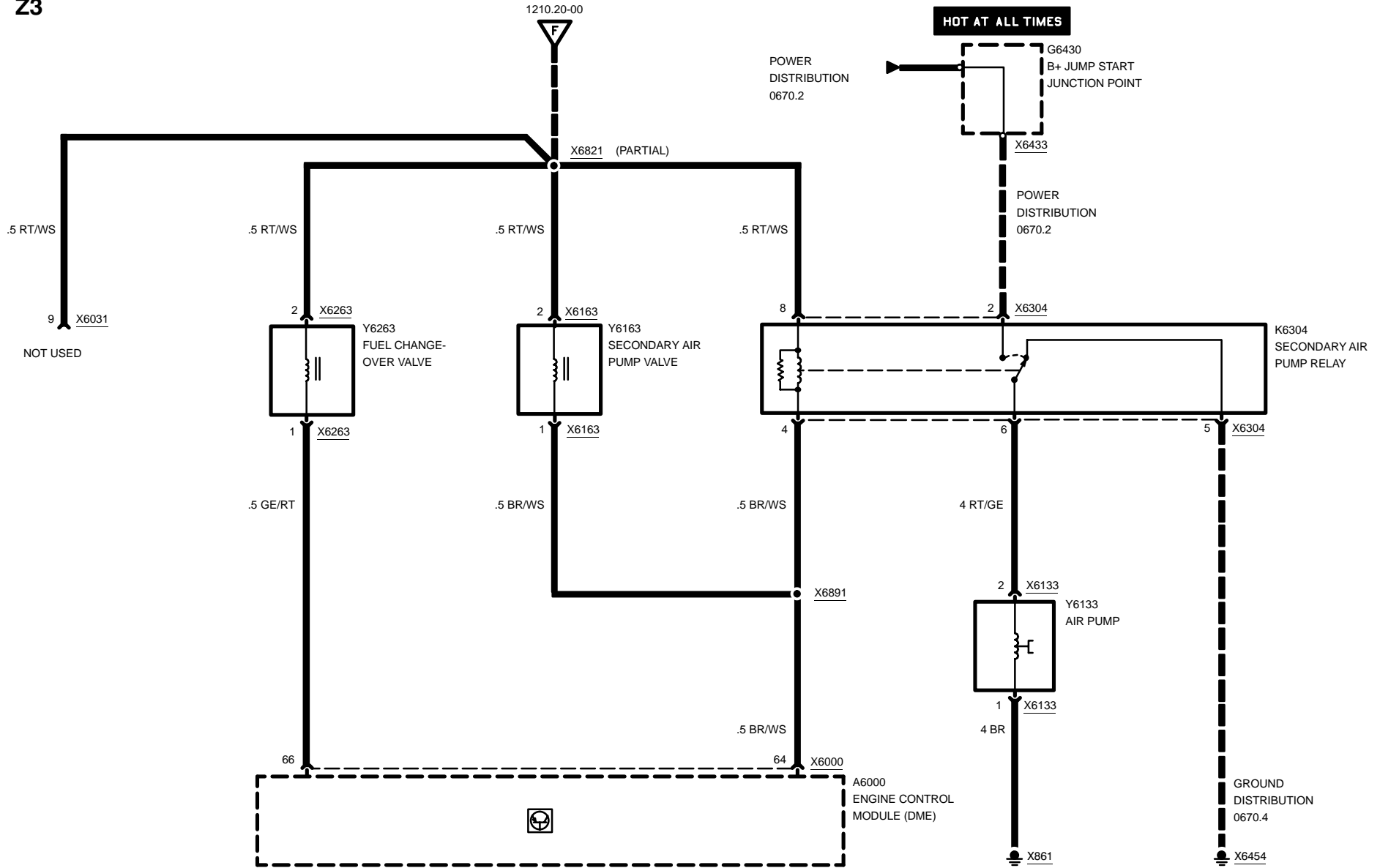

04/99

1210.20-09

1998



1230.0 CHARGING SYSTEM

Z3 ROADSTER

Z3

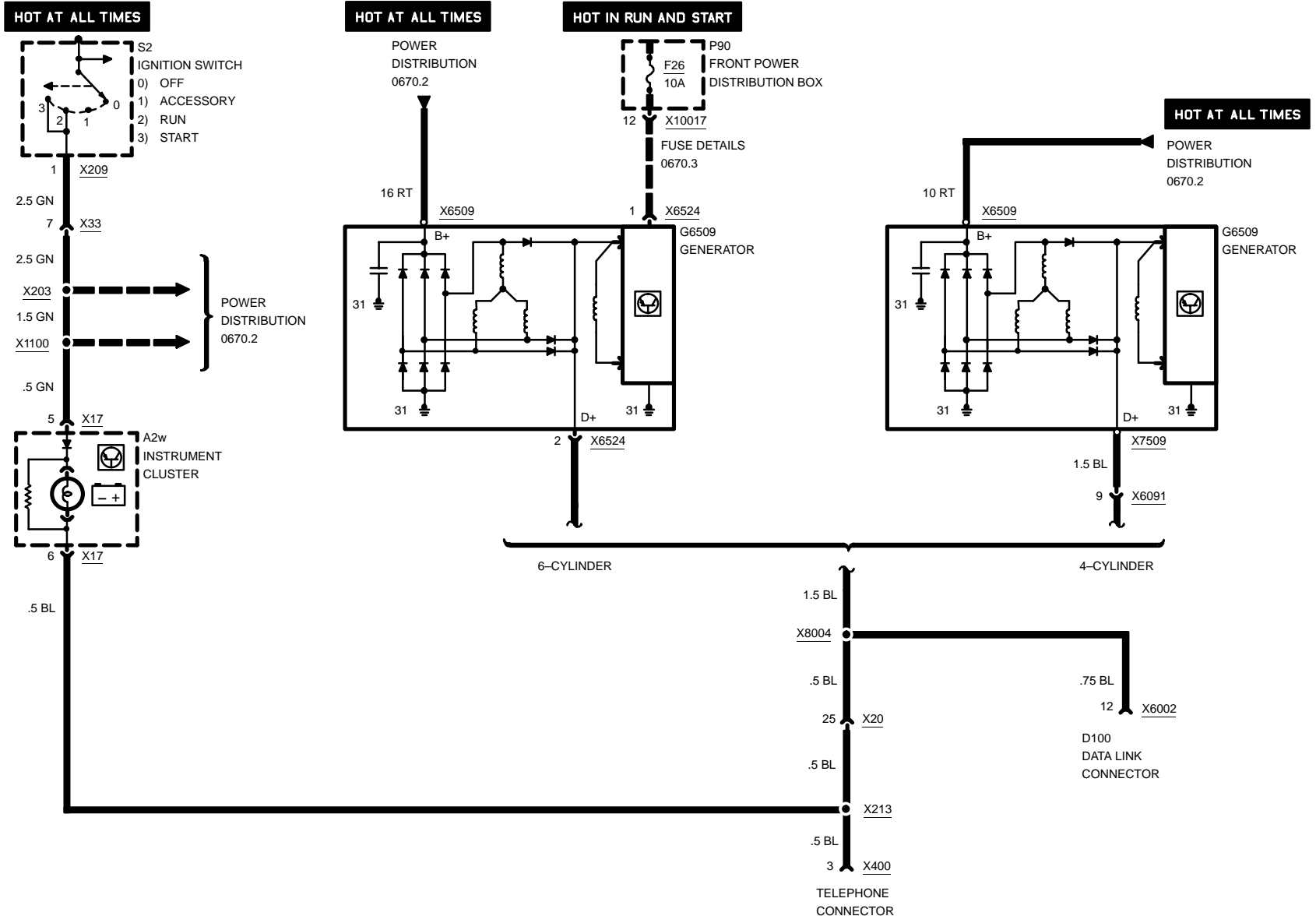

04/99

1230.0-00

1998



Z3

CHARGING SYSTEM

M ROADSTER

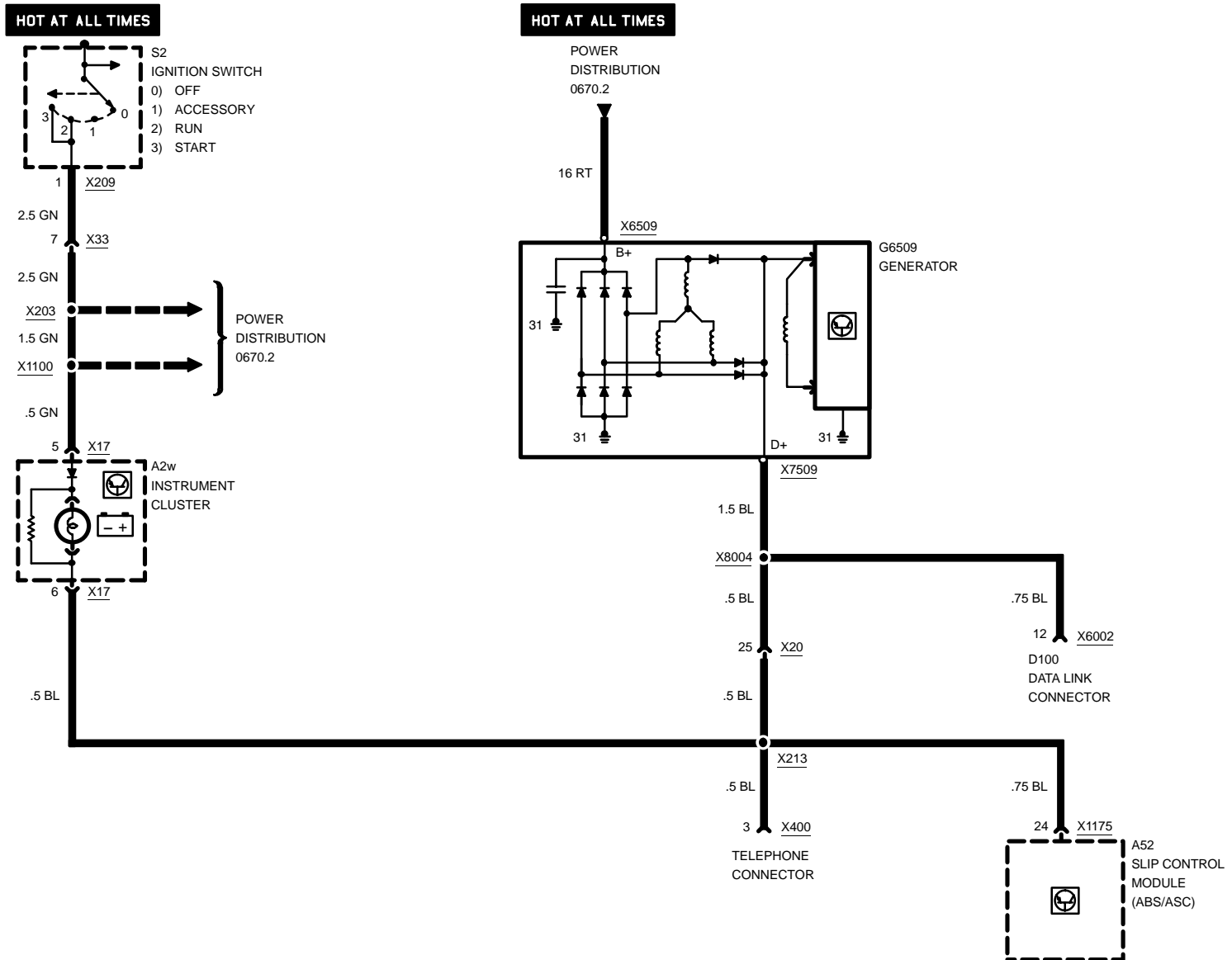

04/99

1230.0-01

1998

1240.0 START

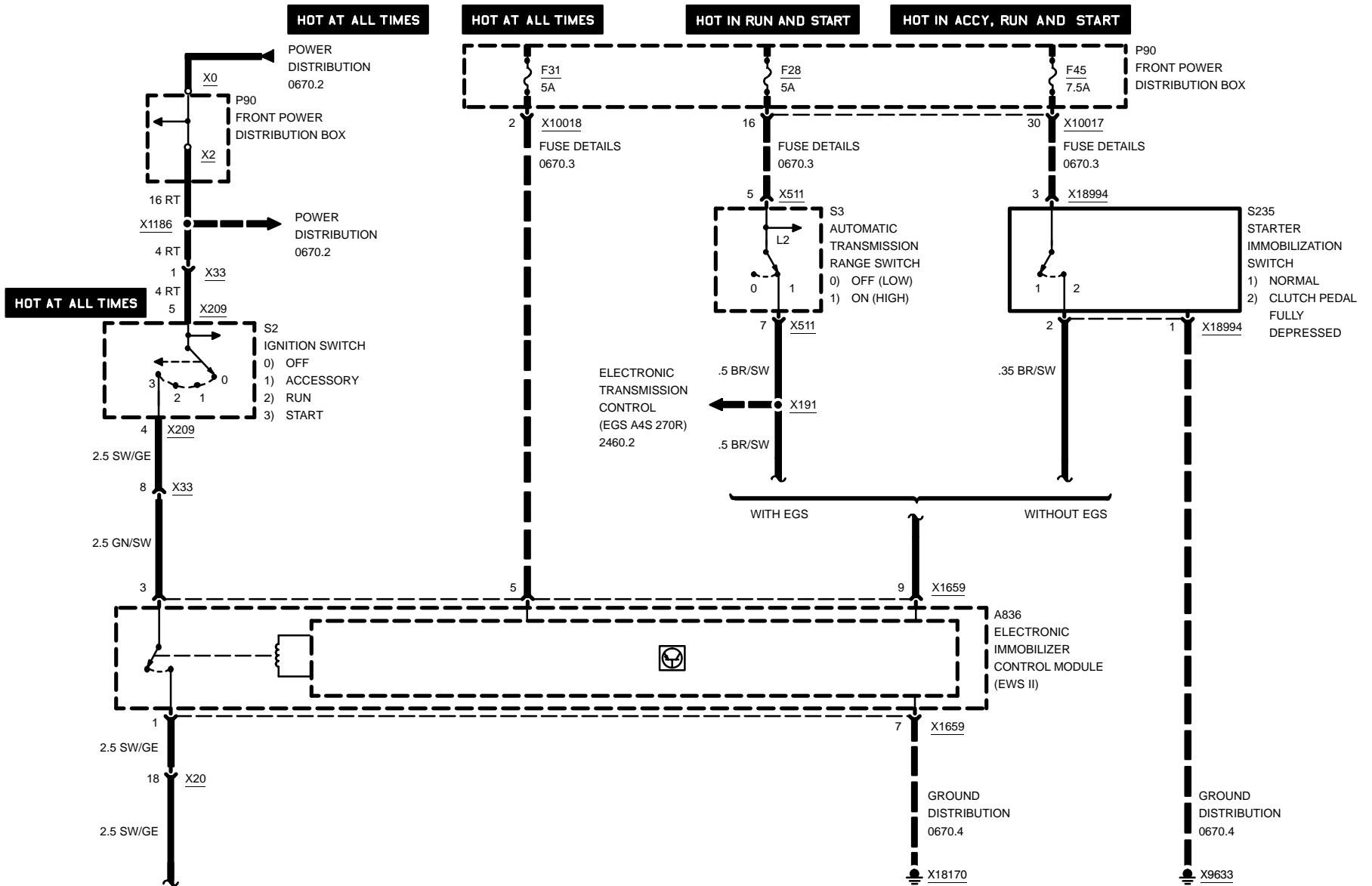

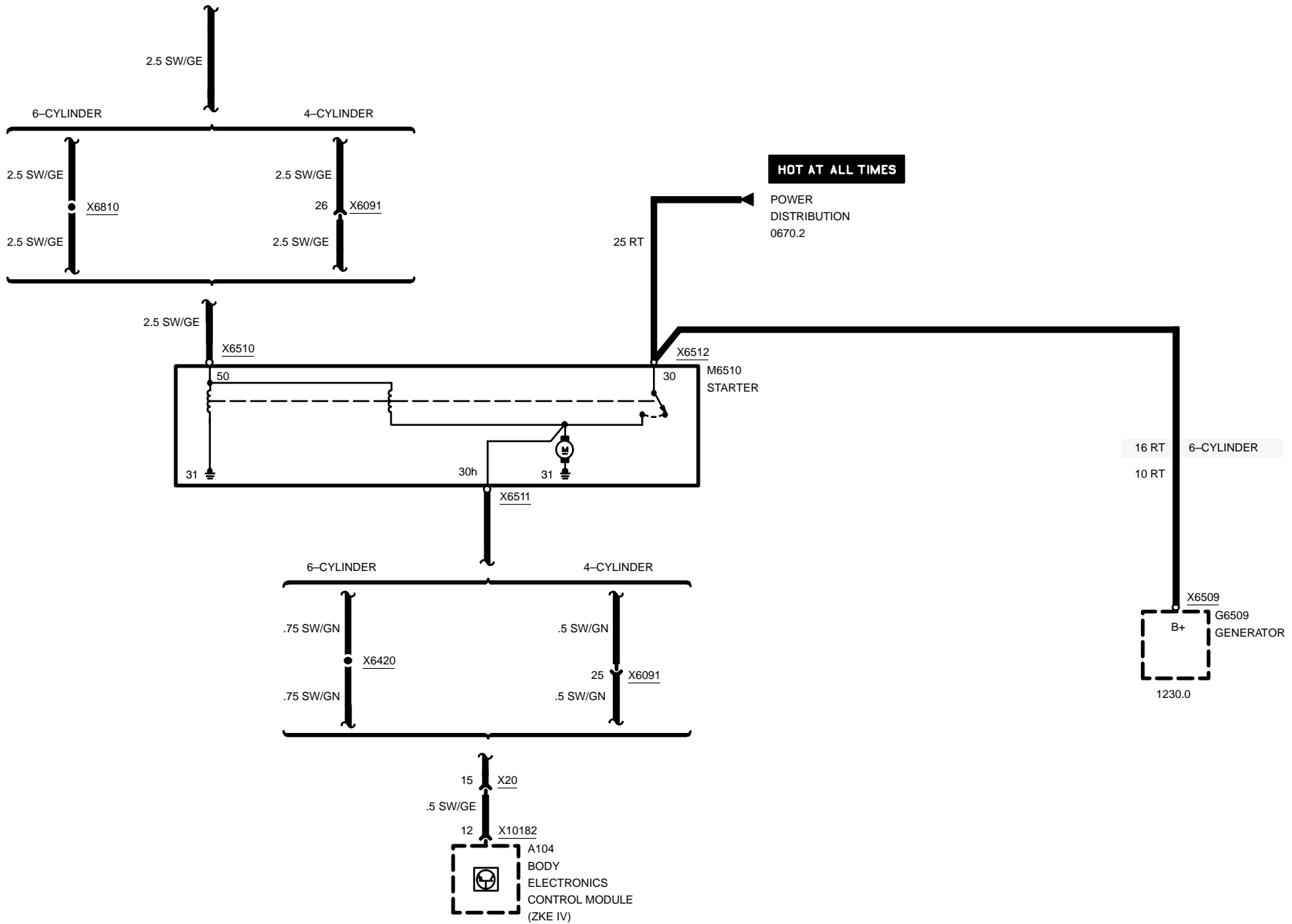



1290.0 E-BOX FAN

M ROADSTER

04/99

1290.0 00

1998

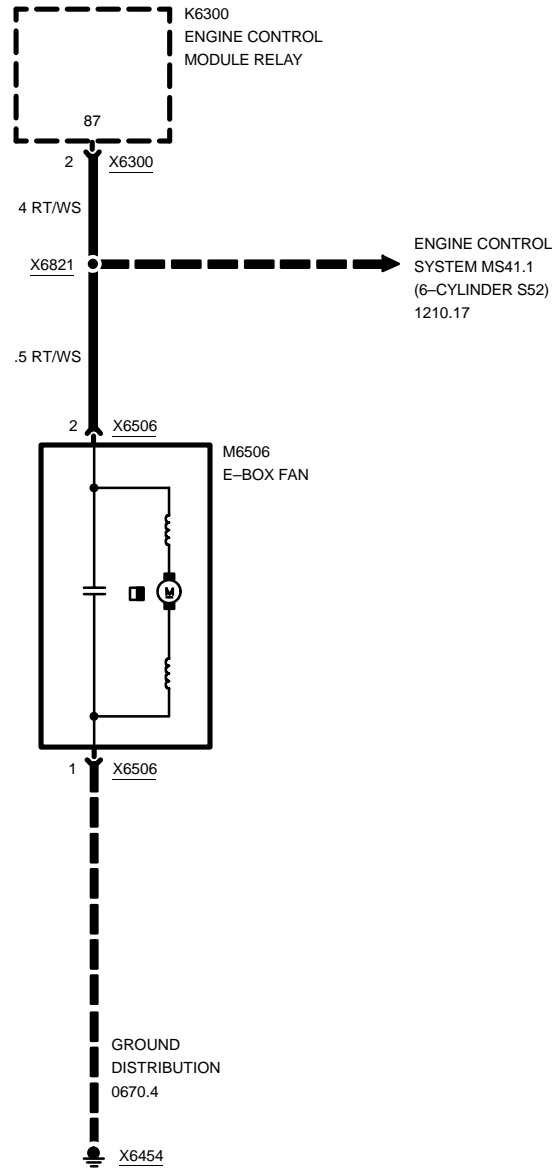

6-CYLINDER

HOT AT ALL TIMES

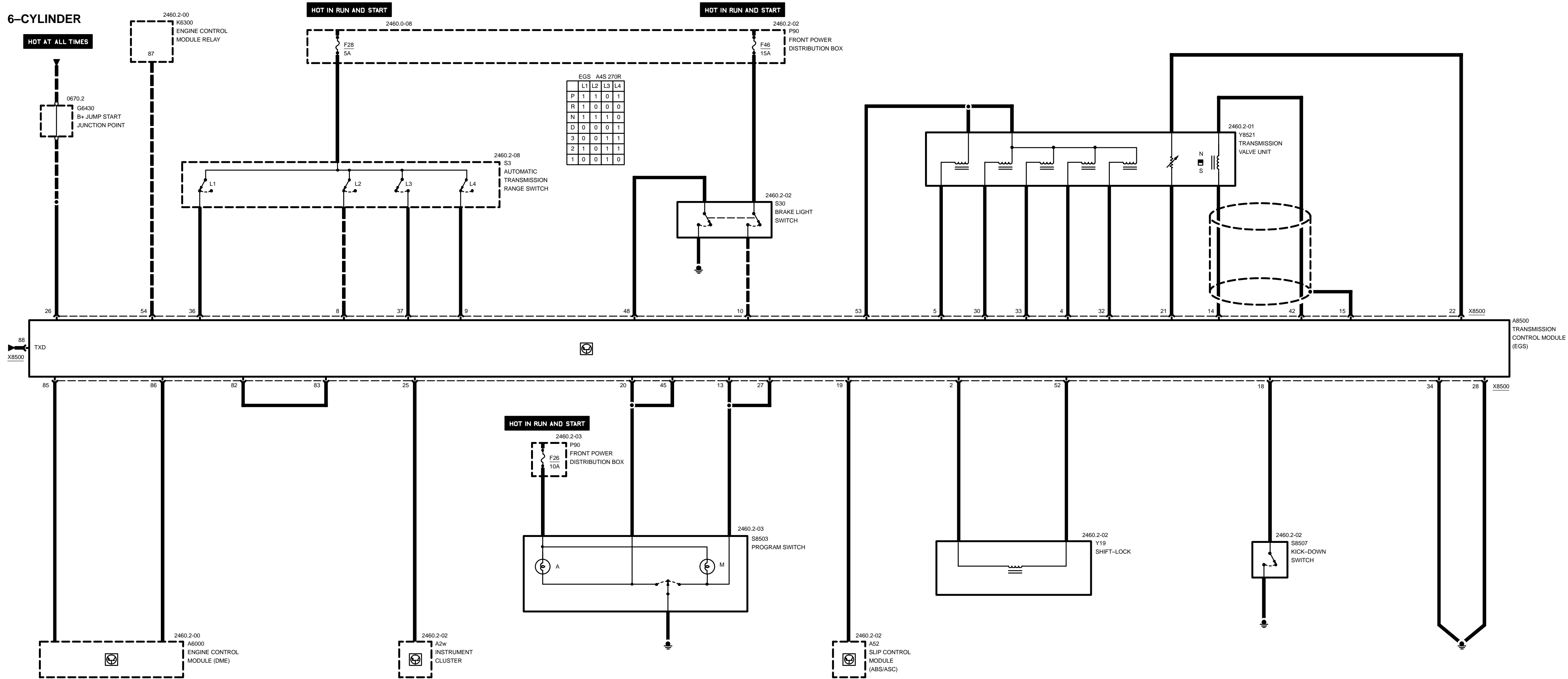

4-CYLINDER

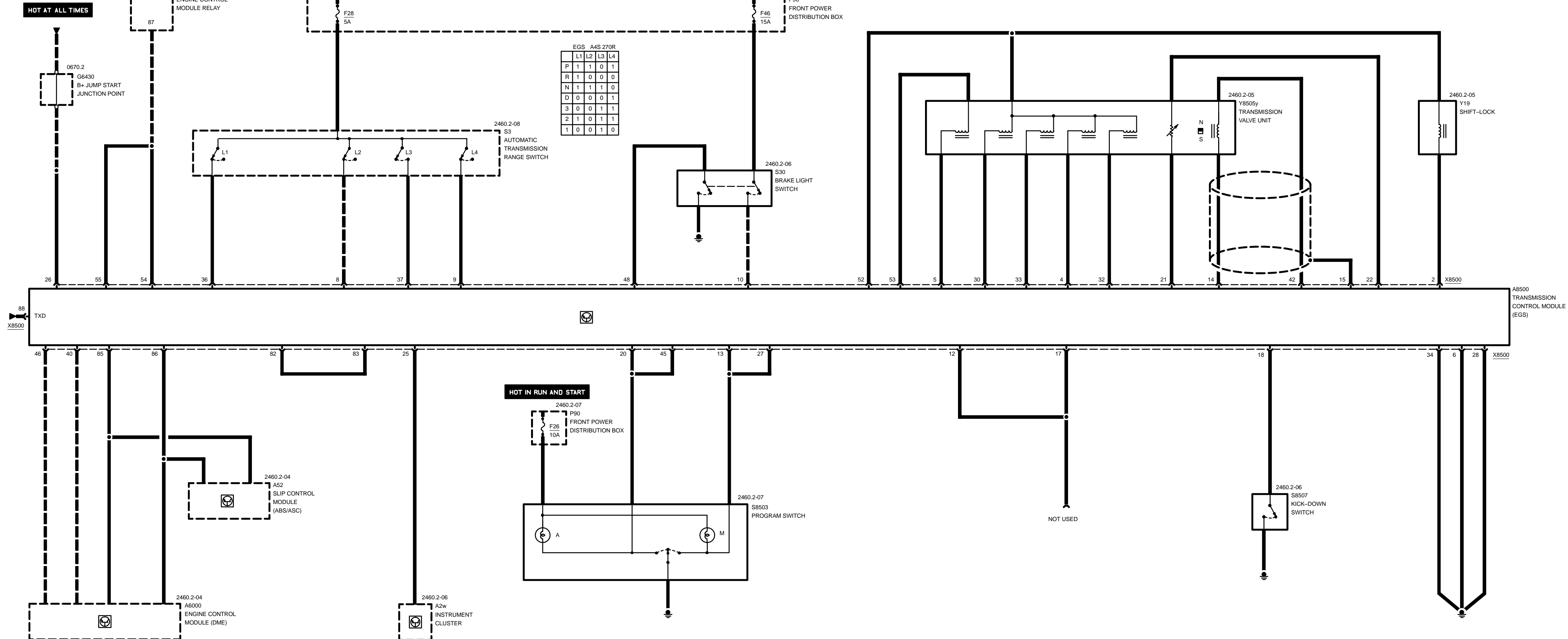

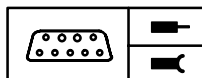

Z3

**Pin Assignments (6-Cylinder)****X8500**

Pin	Type	Description/Function	Connection
177		Not used	
178	M	Ground	Shift-lock
179		Not used	
180	A	Solenoid valve 3 control (-)	Transmission valve unit
181	A	Hydraulic pressure regulator control (-)	Transmission valve unit
182		Not used	
183		Not used	
184	E	Gear range signal L2	Automatic transmission range switch
185	E	Gear range signal L4	Automatic transmission range switch
186	E	Brake pedal position	Brake light switch
187		Not used	
188		Not used	
189	E	Manual mode signal	Program switch
190	E	Output speed (-)	Transmission valve unit
191	M	Ground for shield	Shield for speed sensor
192		Not used	
193		Not used	
194	E	Kick-down signal	Kick-down switch
195	E	ASC signal	Slip control module
196	E	Automatic mode signal	Program switch
197	E	Oil temperature signal (-)	Transmission valve unit
198	E	Oil temperature signal (+)	Transmission valve unit
199		Not used	
200		Not used	
201	A	Fault indicator signal	Instrument cluster
202	E	Battery voltage	B+ jump start junction point
203	A	M-program indication	Program switch
204	M	Ground	Ground point
205		Not used	
206	A	Solenoid valve 1 control (-)	Transmission valve unit

E = Input, A = Output, M = Ground

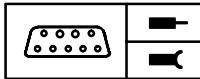

Z3

**Pin Assignments (6-Cylinder)**

Pin	Type	Description/Function	Connection
207		Not used	
208	A	Torque converter clutch solenoid valve control (-)	Transmission valve unit
209	A	Solenoid valve 2 control (-)	Transmission valve unit
210	M	Ground	Ground point
211		Not used	
212	E	Gear range signal L1	Automatic transmission range switch
213	E	Gear range signal L3	Automatic transmission range switch
214		Not used	
215		Not used	
216		Not used	
217		Not used	
218	E	Output speed (+)	Transmission valve unit
219		Not used	
220		Not used	
221	A	A-program indication	Program switch
222		Not used	
223		Not used	
224	E	Brake switch test signal	Brake light switch
225		Not used	
226		Not used	
227		Not used	
228	A	Shift-lock solenoid control	Shift-lock
229	A	Voltage solenoid valves	Transmission valve unit
230	E	Voltage supply terminal 87	Engine control module relay
231		Not used	
232		Not used	
233		Not used	
234		Not used	
235		Not used	
236		Not used	
237		Not used	

E = Input, A = Output, M = Ground

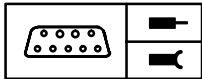

Z3

**Pin Assignments (6-Cylinder)**

Pin	Type	Description/Function	Connection
238		Not used	
239		Not used	
240		Not used	
241		Not used	
242		Not used	
243		Not used	
244		Not used	
245		Not used	
246		Not used	
247		Not used	
248		Not used	
249		Not used	
250		Not used	
251		Not used	
252		Not used	
253		Not used	
254		Not used	
255		Not used	
256		Not used	
257		Not used	
258	E/A	Jumper plug	
259	E/A	Jumper plug	
260		Not used	
261	E/A	Can-Low	Engine control module
262	E/A	Can-High	Engine control module
263		Not used	
264	E/A	TxD diagnostic data link	Data link connector

E = Input, A = Output, M = Ground

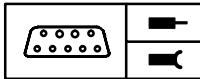

Z3

**Pin Assignments (4-Cylinder)****X8500**

Pin	Type	Description/Function	Connection
265		Not used	
266	A	Shift-lock solenoid control	Shift-lock
267		Not used	
268	A	Solenoid valve 3 control (-)	Transmission valve unit
269	A	Hydraulic pressure regulator control (-)	Transmission valve unit
270	M	Ground	Ground point
271		Not used	
272	E	Gear range signal L2	Automatic transmission range switch
273	E	Gear range signal L4	Automatic transmission range switch
274	E	Brake pedal position	Brake light switch
275		Not used	
276	E	Sport mode signal	Not used
277	E	Manual mode signal	Program switch
278	E	Output speed (-)	Transmission valve unit
279	M	Ground for shield	Shield for speed sensor
280		Not used	
281	A	S-program indication	Not used
282	E	Kick-down signal	Kick-down switch
283		Not used	
284	E	Automatic mode signal	Program switch
285	E	Oil temperature signal (-)	Transmission valve unit
286	E	Oil temperature signal (+)	Transmission valve unit
287		Not used	
288		Not used	
289	A	Fault indicator signal	Instrument cluster
290	E	Battery voltage	B+ jump start junction point
291	A	M-program indication	Program switch
292	M	Ground	Ground point
293		Not used	
294	A	Solenoid valve 1 control (-)	Transmission valve unit

E = Input, A = Output, M = Ground

Z3

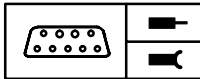

Pin Assignments (4-Cylinder)

Pin	Type	Description/Function	Connection
295		Not used	
296	A	Torque converter clutch solenoid valve control (-)	Transmission valve unit
297	A	Solenoid valve 2 control (-)	Transmission valve unit
298	M	Ground	Ground point
299		Not used	
300	E	Gear range signal L1	Automatic transmission range switch
301	E	Gear range signal L3	Automatic transmission range switch
302		Not used	
303		Not used	
304	E	RPM speed signal TD	Engine control module
305		Not used	
306	E	Output speed (+)	Transmission valve unit
307		Not used	
308		Not used	
309	A	A-program indication	Program switch
310	E	A/C compressor-ON-signal	Engine control module
311		Not used	
312	E	Brake switch test signal	Brake light switch
313		Not used	
314		Not used	
315		Not used	
316	A	Voltage supply	Shift-lock/Transmission valve unit
317	E	Voltage pressure regulator	Transmission valve unit
318	E	Voltage supply, terminal 87	Engine control module relay
319	E	Voltage supply, terminal 87	Engine control module relay
320		Not used	
321		Not used	
322		Not used	
323		Not used	
324		Not used	
325		Not used	

E = Input, A = Output, M = Ground



Z3

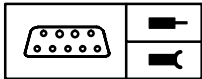

Pin Assignments (4-Cylinder)

Pin	Type	Description/Function	Connection
326		Not used	
327		Not used	
328		Not used	
329		Not used	
330		Not used	
331		Not used	
332		Not used	
333		Not used	
334		Not used	
335		Not used	
336		Not used	
337		Not used	
338		Not used	
339		Not used	
340		Not used	
341		Not used	
342		Not used	
343		Not used	
344		Not used	
345		Not used	
346	E/A	Jumper plug	
347	E/A	Jumper plug	
348		Not used	
349	E/A	Can-Low	Engine control module
350	E/A	Can-High	Engine control module
351		Not used	
352	E/A	TxD diagnostic data link	Data link connector

E = Input, A = Output, M = Ground



ELECTRONIC TRANSMISSION CONTROL (EGS A4S 270R)

6-CYLINDER

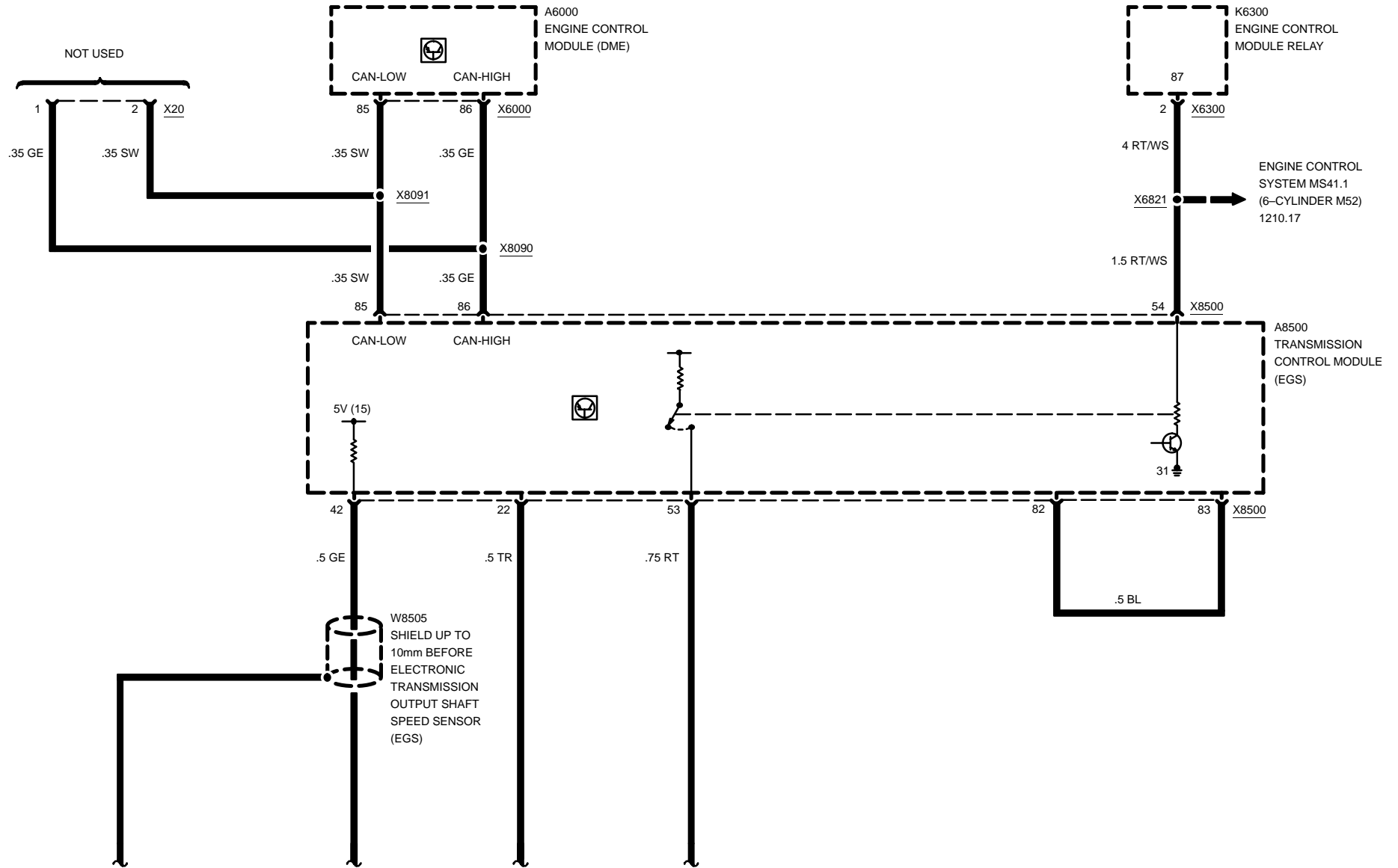

04/99

2460.2-00

1998

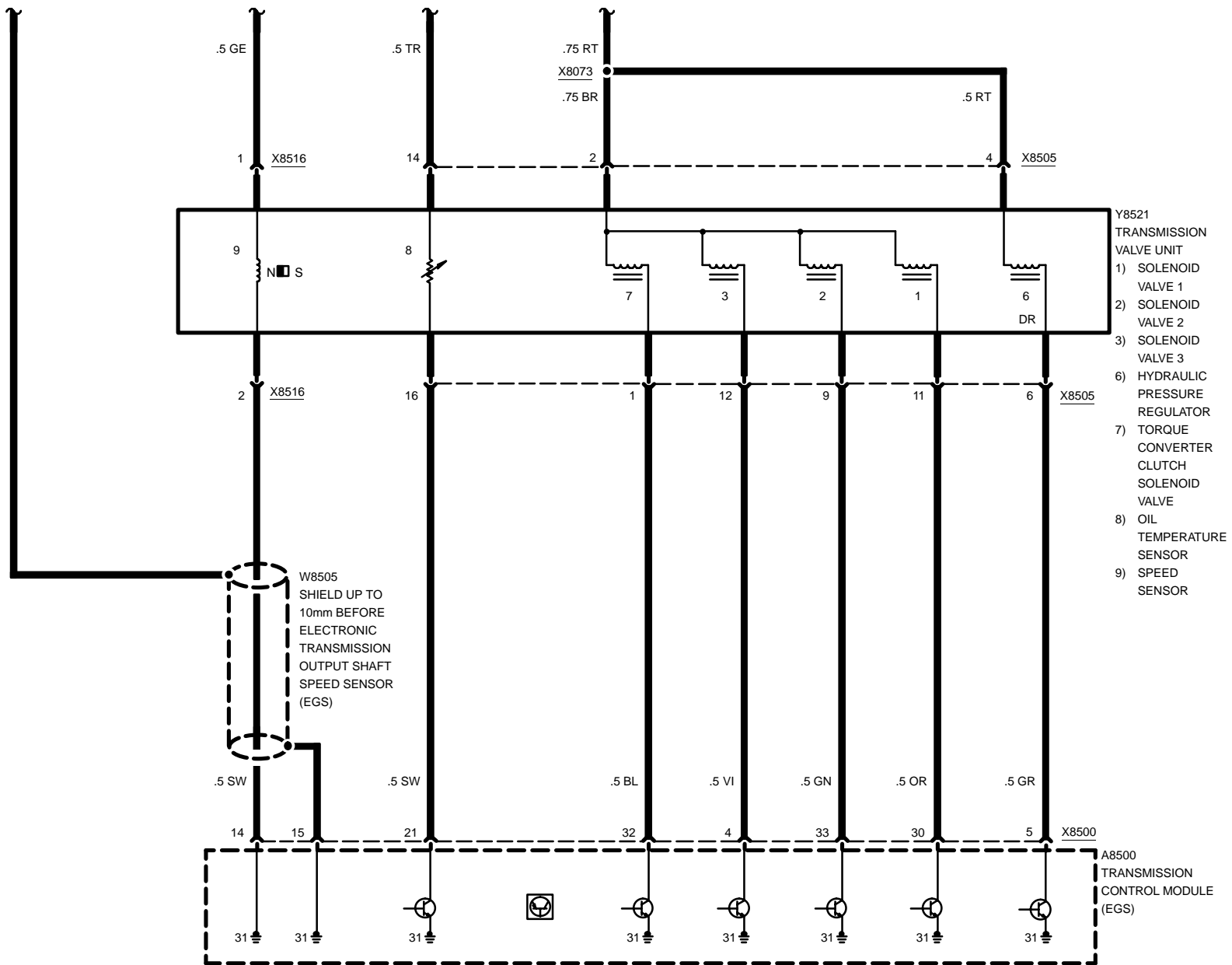



Z3

ELECTRONIC TRANSMISSION CONTROL (EGS A4S 270R)

6-CYLINDER

SHIFT LOCK, DATA LINK, KICK-DOWN SWITCH

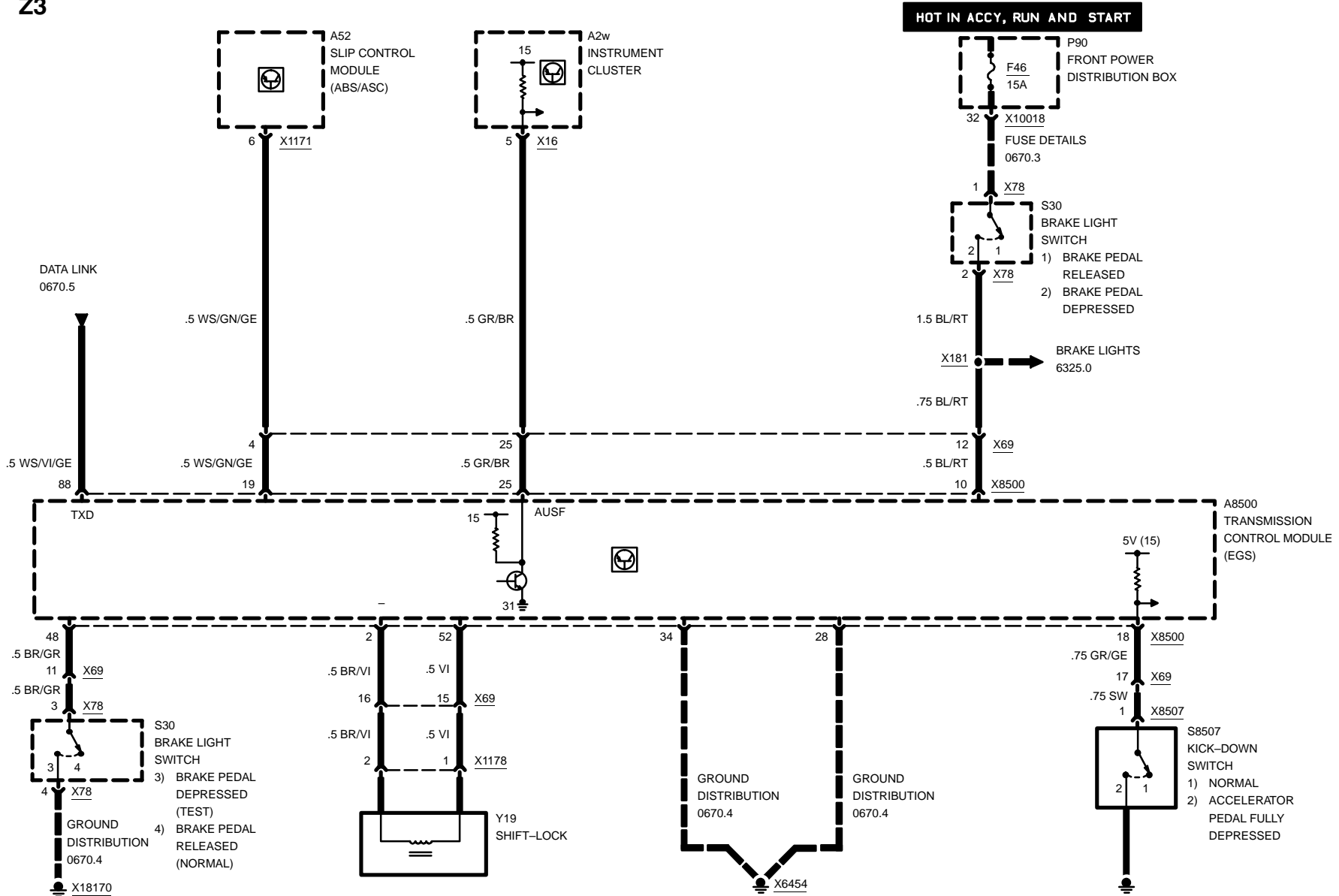

04/99

2460.2-02

1998

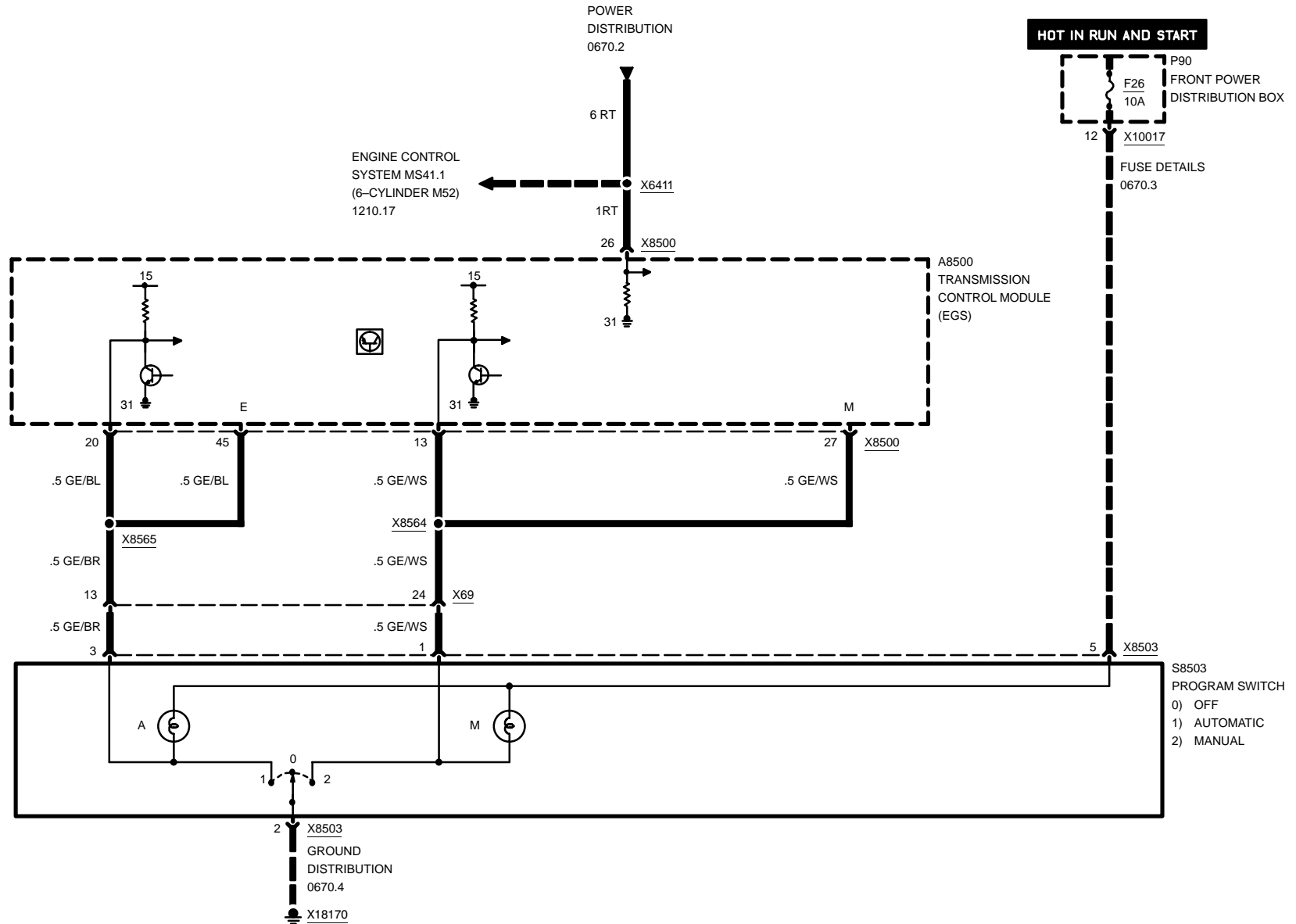



Z3

ELECTRONIC TRANSMISSION CONTROL (EGS A4S 270R)

4-CYLINDER

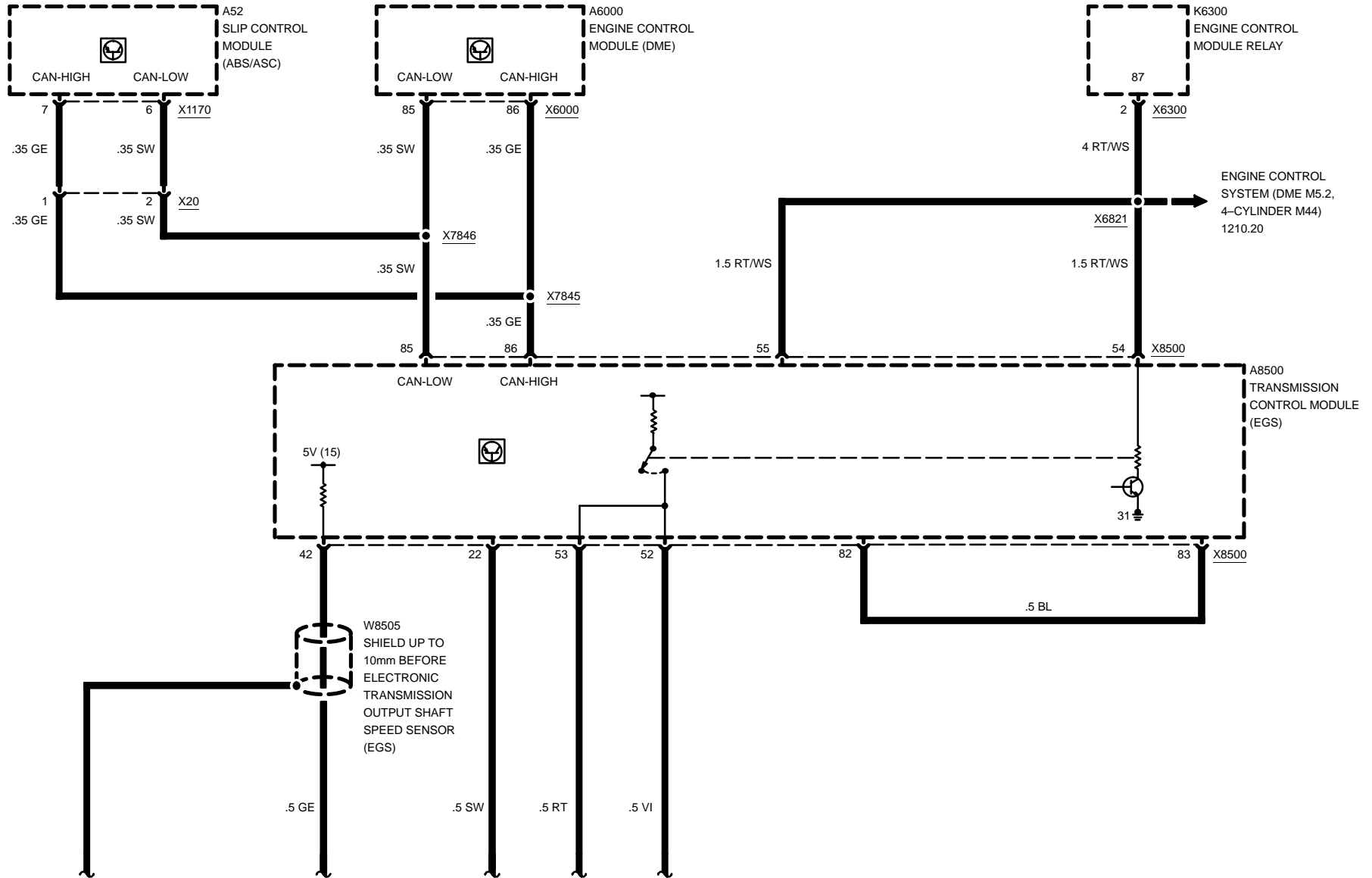

04/99

2460.2-04

1998

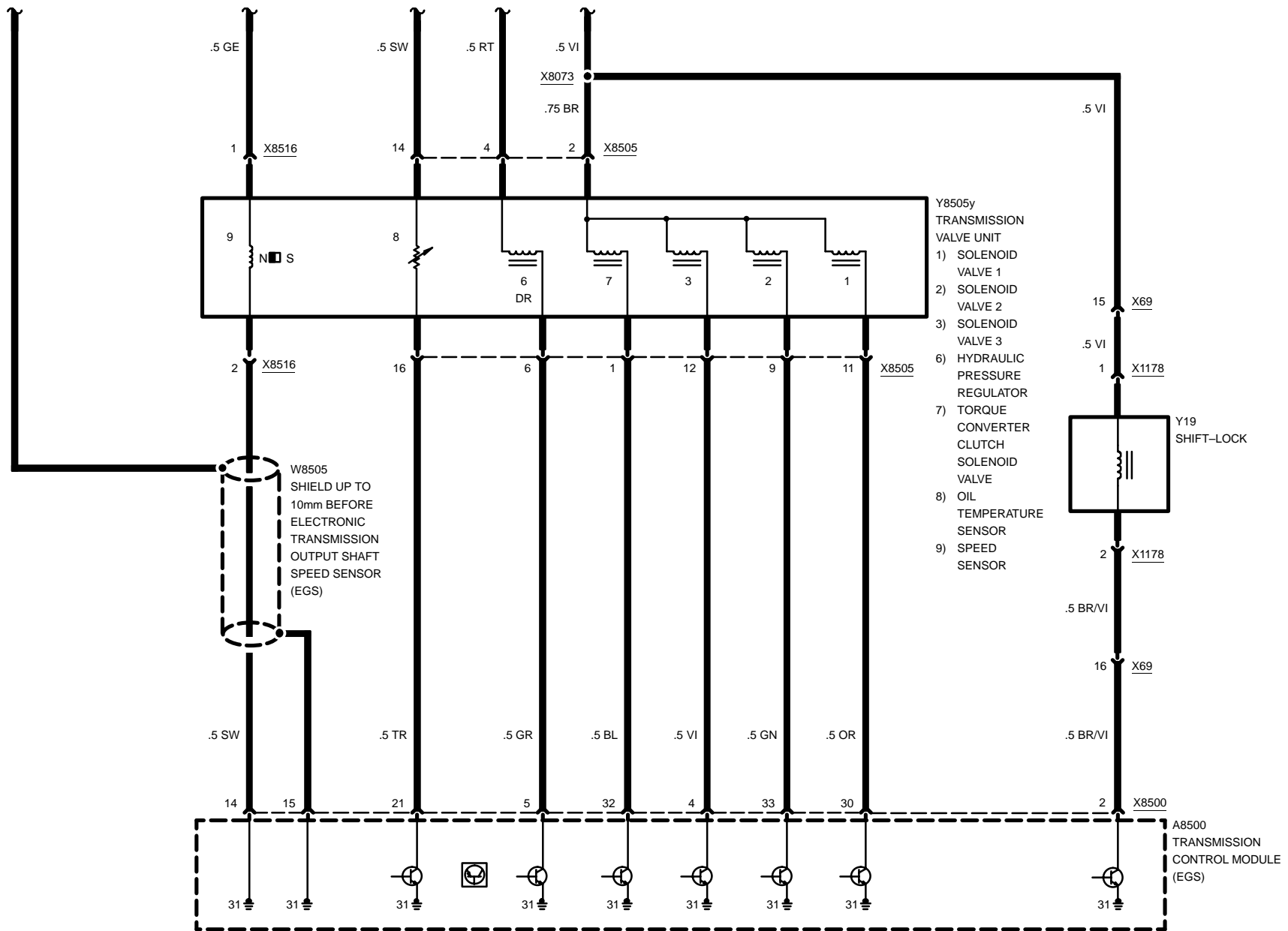



Z3

ELECTRONIC TRANSMISSION CONTROL (EGS A4S 270R)

4-CYLINDER

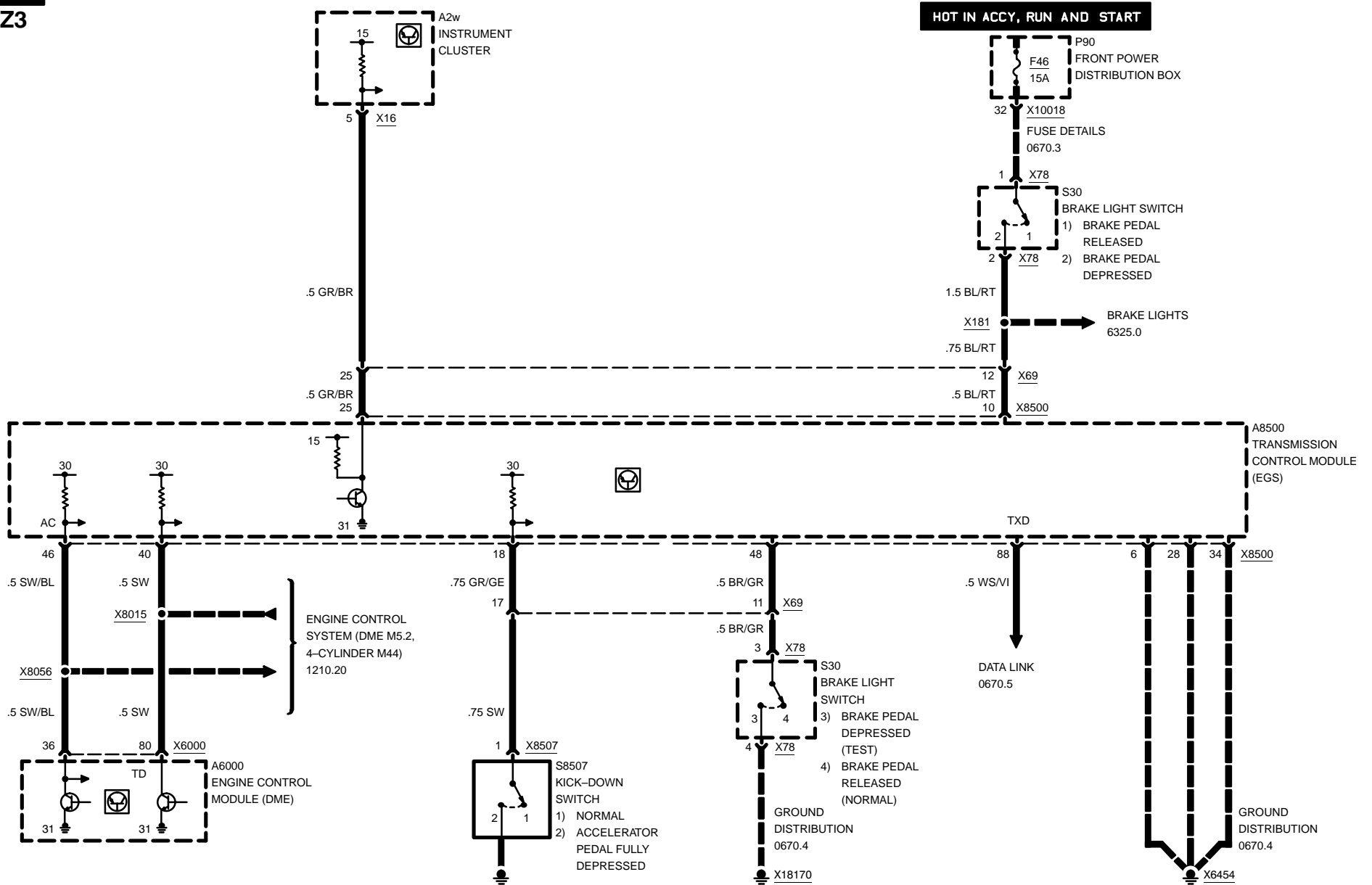

04/99

2460.2-06

1998

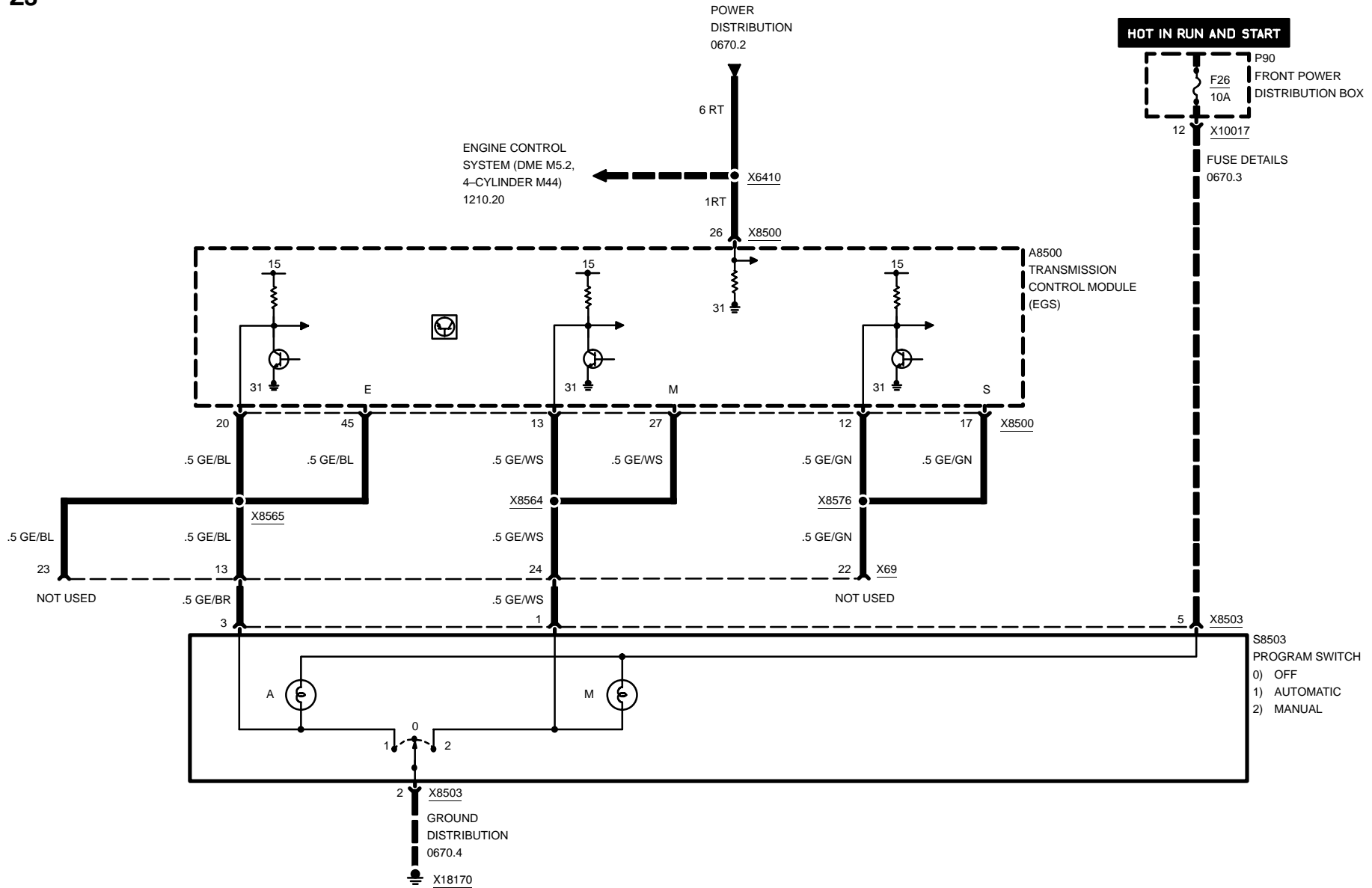

ELECTRONIC TRANSMISSION CONTROL (EGS A4S 270R)

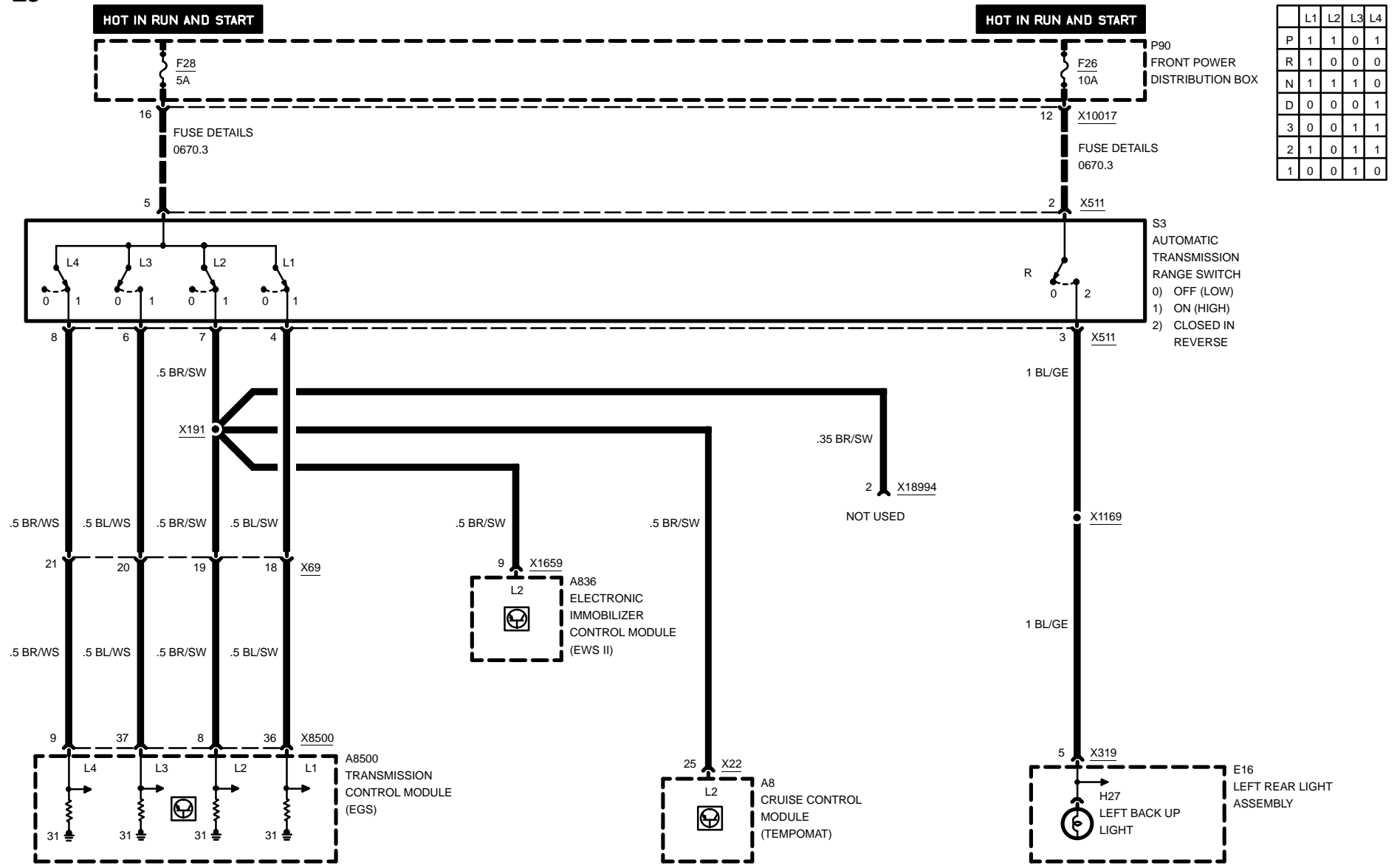

	L1	L2	L3	L4
P	1	1	0	1
R	1	0	0	0
N	1	1	1	0
D	0	0	0	1
3	0	0	1	1
2	1	0	1	1
1	0	0	1	0

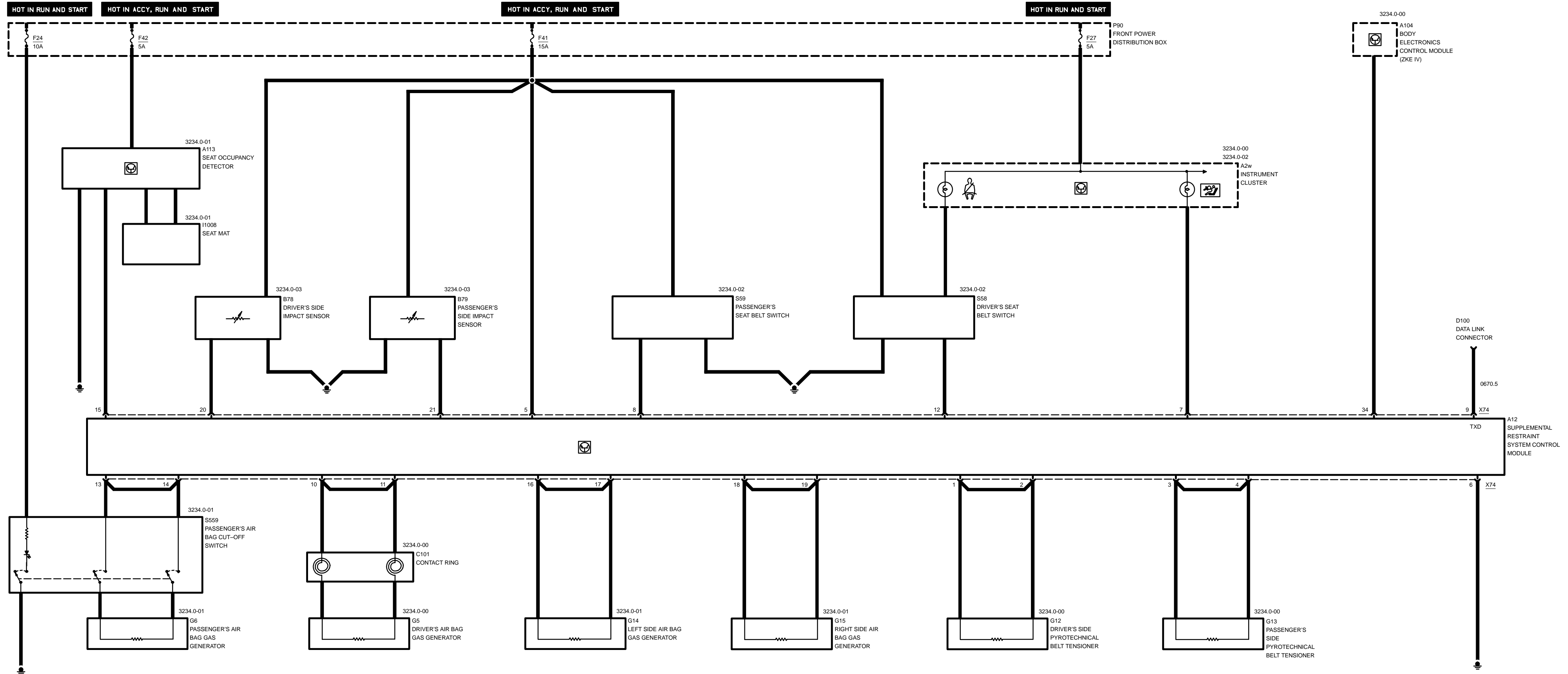

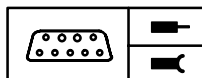

Z3

**Pin Assignments****X74**

Pin	Type	Description/Function	Connection
1	A	Pyrotechnical belt tensioner	Driver's side pyrotechnical belt tensioner
2	A	Pyrotechnical belt tensioner	Driver's side pyrotechnical belt tensioner
3	A	Pyrotechnical belt tensioner	Passenger's side pyrotechnical belt tensioner
4	A	Pyrotechnical belt tensioner	Passenger's side pyrotechnical belt tensioner
5	E	Power supply	Front power distribution box, fuse 41
6	M	Ground	Ground point
7	A	Air bag warning indicator	Instrument cluster
8	E	Belt switch	Passenger's seat belt switch
9	E/A	TxD diagnostic data line	Data link connector
10	A	Air bag (+)	Driver's air bag gas generator
11	A	Air bag (-)	Driver's air bag gas generator
12	E	Belt switch	Driver's seat belt switch
13	A	Air bag (+)	Passenger's air bag gas generator
14	A	Air bag (-)	Passenger's air bag gas generator
15	E	Seat occupancy detector	Seat occupancy detector
16	A	Gas generator	Gas generator, left side air bag
17	A	Gas generator	Gas generator, left side air bag
18	A	Gas generator	Gas generator, right side air bag
19	A	Gas generator	Gas generator, right side air bag
20	E	Impact sensor	Driver's side impact sensor
21	E	Impact sensor	Passenger's side impact sensor
22		Not used	
23		Not used	
24		Not used	
25		Not used	
26		Not used	
27		Not used	
28		Not used	
29		Not used	

E = Input, A = Output, M = Ground



Z3

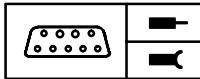

Pin Assignments

Pin	Type	Description/Function	Connection
30		Not used	
31		Not used	
32		Not used	
33		Not used	
34	A	Crash signal	Body electronics control module (ZKE IV)
35		Not used	
36		Not used	
37		Not used	
38		Not used	
39		Not used	
40		Not used	
41		Not used	
42		Not used	
43		Not used	
44		Not used	
45		Not used	
46		Not used	
47		Not used	
48		Not used	
49		Not used	
50		Not used	

E = Input, A = Output, M = Ground



SUPPLEMENTAL RESTRAINT SYSTEM (AIR BAG)

Z3

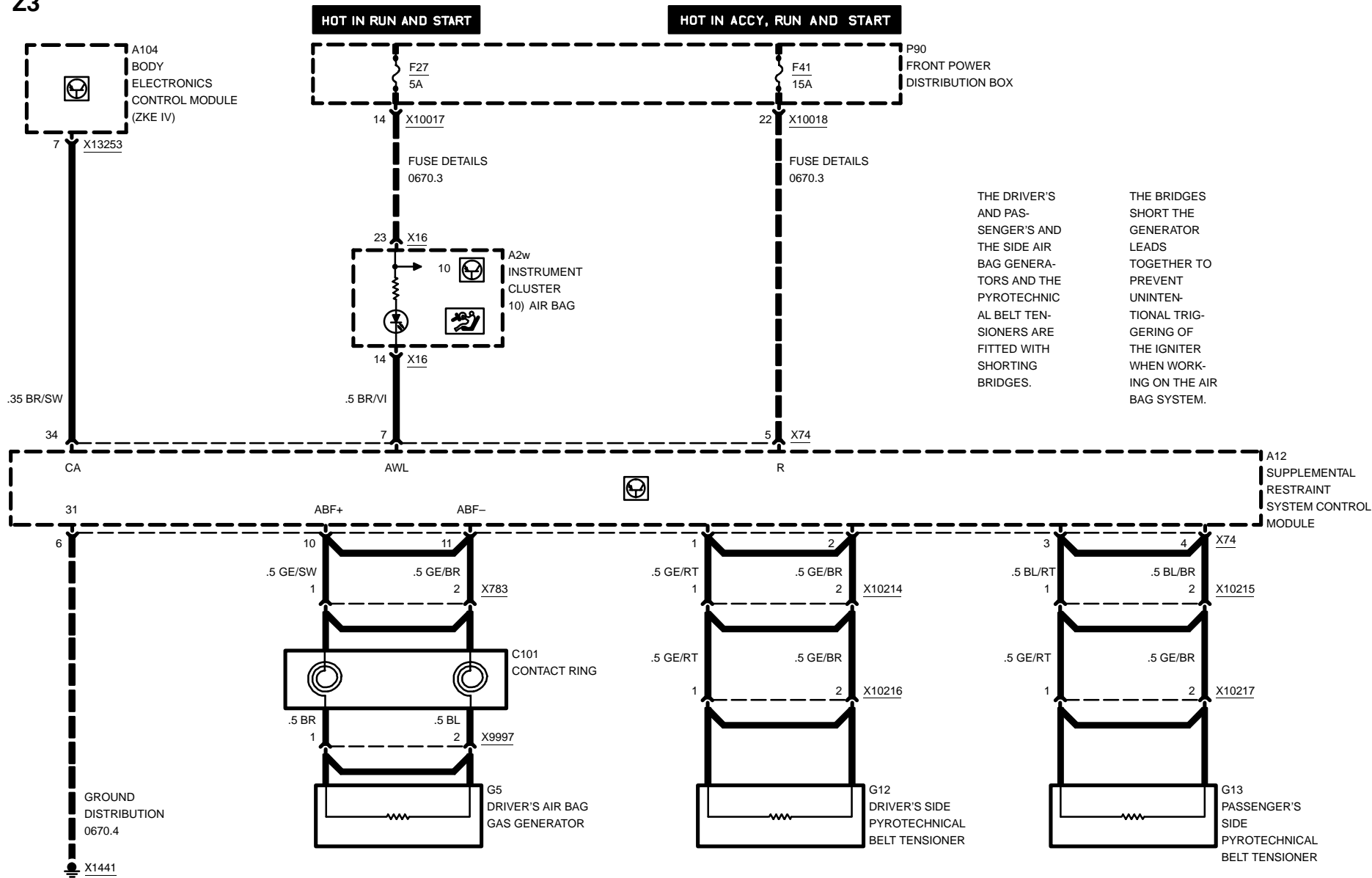

04/99

3234.0-00

1998

SUPPLEMENTAL RESTRAINT SYSTEM (AIR BAG)

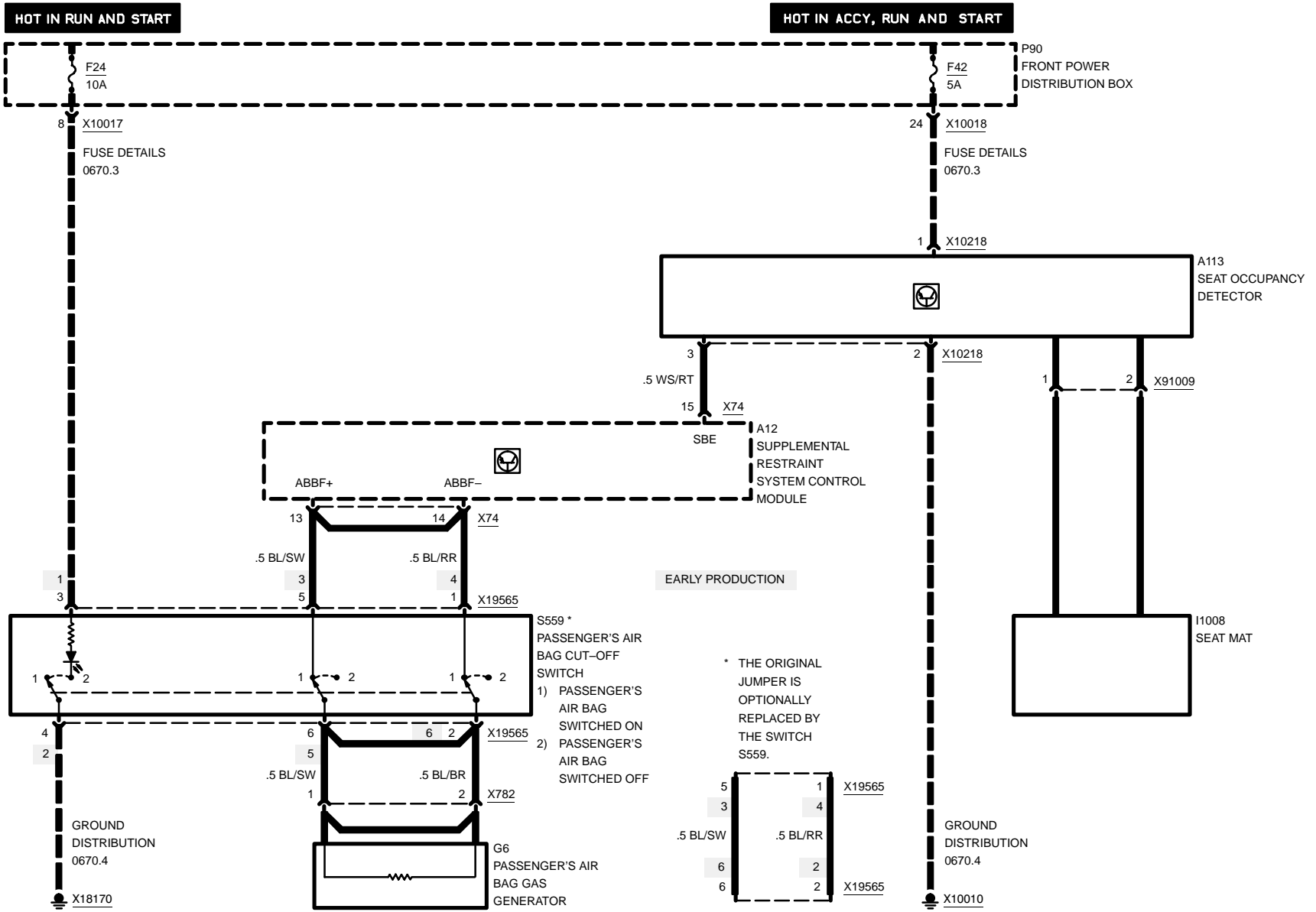

EARLY PRODUCTION

* THE ORIGINAL JUMPER IS OPTIONALLY REPLACED BY THE SWITCH S559.

- S559 *
PASSENGER'S AIR BAG CUT-OFF SWITCH
- 1) PASSENGER'S AIR BAG SWITCHED ON
 - 2) PASSENGER'S AIR BAG SWITCHED OFF

SUPPLEMENTAL RESTRAINT SYSTEM (AIR BAG)

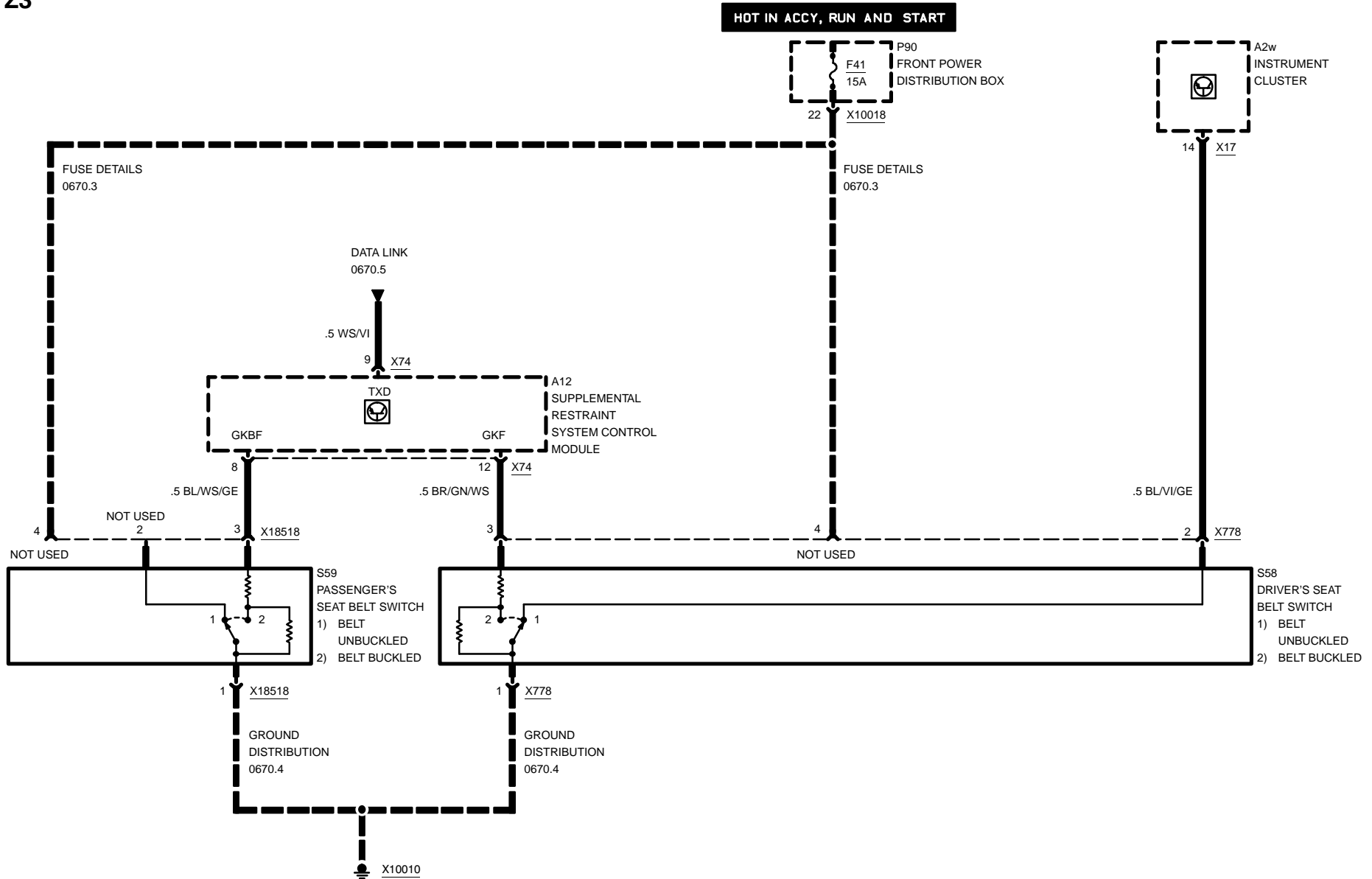



SUPPLEMENTAL RESTRAINT SYSTEM (AIR BAG)

LATE PRODUCTION

SIDE AIR BAG

HOT IN ACCY, RUN AND START

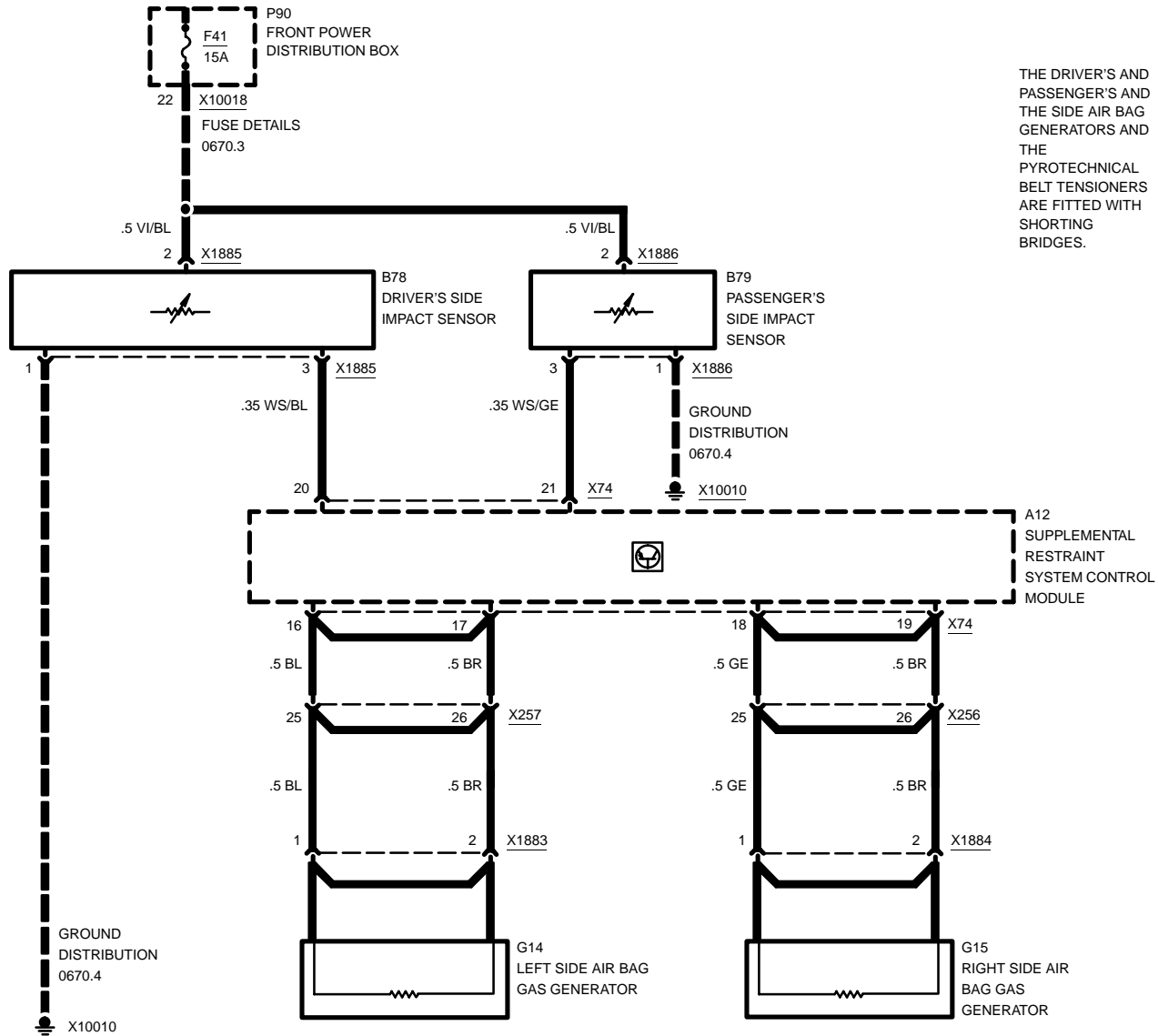

THE DRIVER'S AND PASSENGER'S AND THE SIDE AIR BAG GENERATORS AND THE PYROTECHNICAL BELT TENSIONERS ARE FITTED WITH SHORTING BRIDGES.

THE BRIDGES SHORT THE GENERATOR LEADS TOGETHER TO PREVENT UNINTENTIONAL TRIGGERING OF THE IGNITER WHEN WORKING ON THE AIR BAG SYSTEM.

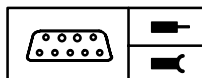

Z3

**Pin Assignments****X1170**

Pin	Type	Description/Function	Connection
51	A	ABS relay	ABS relay
52	A	Activate left front inlet valve	ABS hydraulic unit
53		Not used	
54		Not used	
55	M	Ground	Ground point
56		Not used	
57	A	RxD diagnostic data link	Data link connector
58	E	Terminal 15	Fuse 21
59	E	Voltage supply	ABS pump motor relay
60		Not used	
61		Not used	
62		Not used	
63	A	Ground, left rear speed sensor	Left rear speed sensor
64	A	Ground, right rear speed sensor	Right rear speed sensor
65	E	Signal, right front speed sensor	Right front speed sensor
66	A	Ground, left front speed sensor	Left front speed sensor
67	M	Ground	Ground point
68		Not used	
69	E	Terminal 15	Fuse 21
70		Not used	
71		Not used	
72	A	Activate right front inlet valve	ABS hydraulic unit
73	A	Activate pump relay	ABS pump motor realy
74	A	Activate rear axle inlet valve	ABS hydraulic unit
75	A	Activate left front outlet valve	ABS hydraulic unit
76	M	Ground	Ground point
77	E	Power protection	ABS hydraulic unit
78	E/A	TxD diagnostic data link	Data link connector
79	E	Terminal 54	Brake light switch
80		Not used	

E = Input, A = Output, M = Ground



Z3

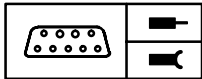

Pin Assignments

Pin	Type	Description/Function	Connection
81		Not used	
82		Not used	
83		Not used	
84	E	Signal, left rear speed sensor	Left rear speed sensor
85	E	Signal, right rear speed sensor	Right rear speed sensor
86	A	Ground, right front speed sensor	Right front speed sensor
87	E	Signal, left front speed sensor	Left front speed sensor
88		Not used	
89	A	Activate rear outlet valve	ABS hydraulic unit
90	A	Activate rear front inlet valve	ABS hydraulic unit
91	M	Ground	Ground point
92	A	Activate ABS lamp control	Instrument cluster

E = Input, A = Output, M = Ground



Z3

SLIP CONTROL (ABS)

M ROADSTER

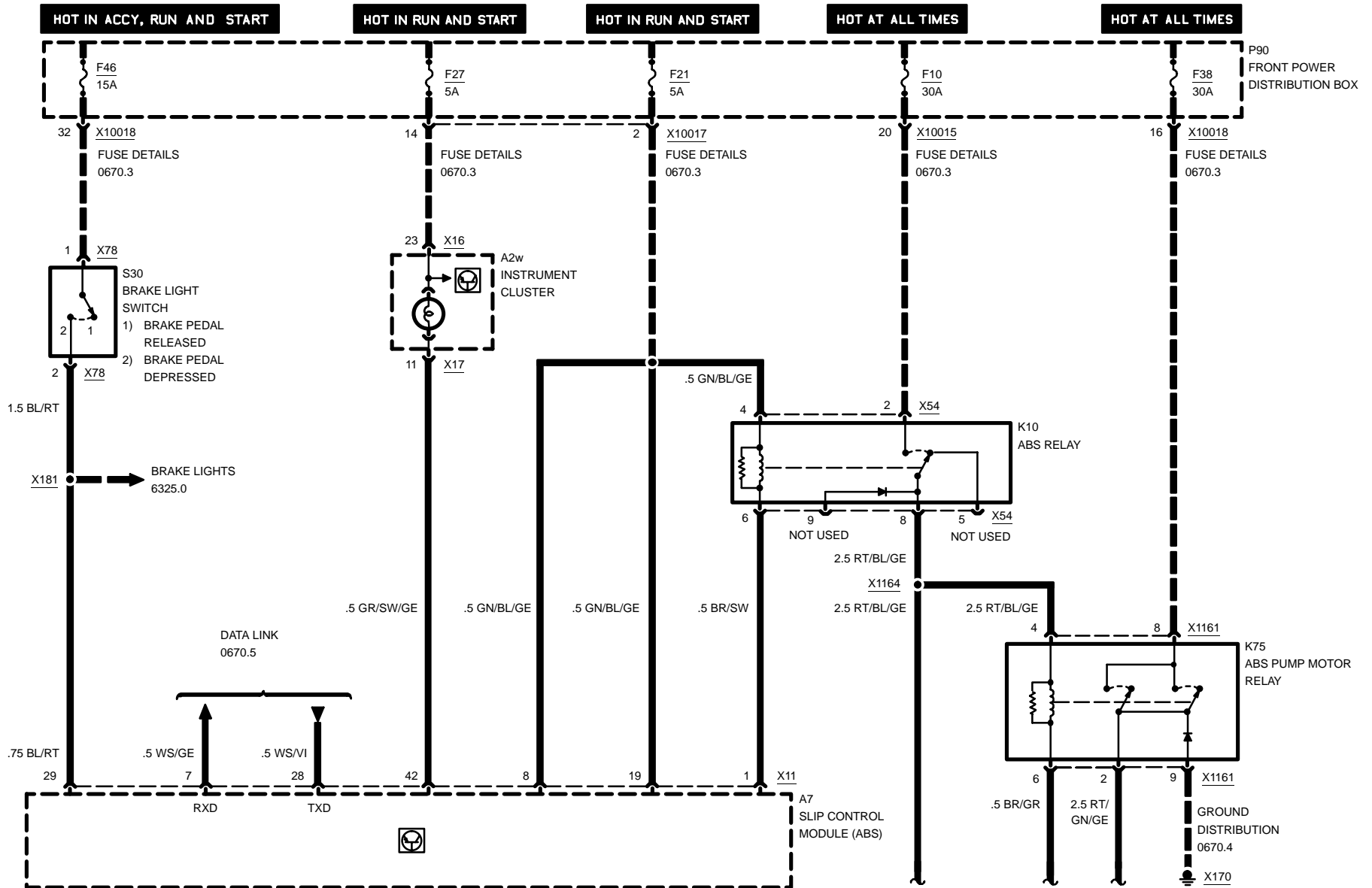

04/99

3450.0-00

1998

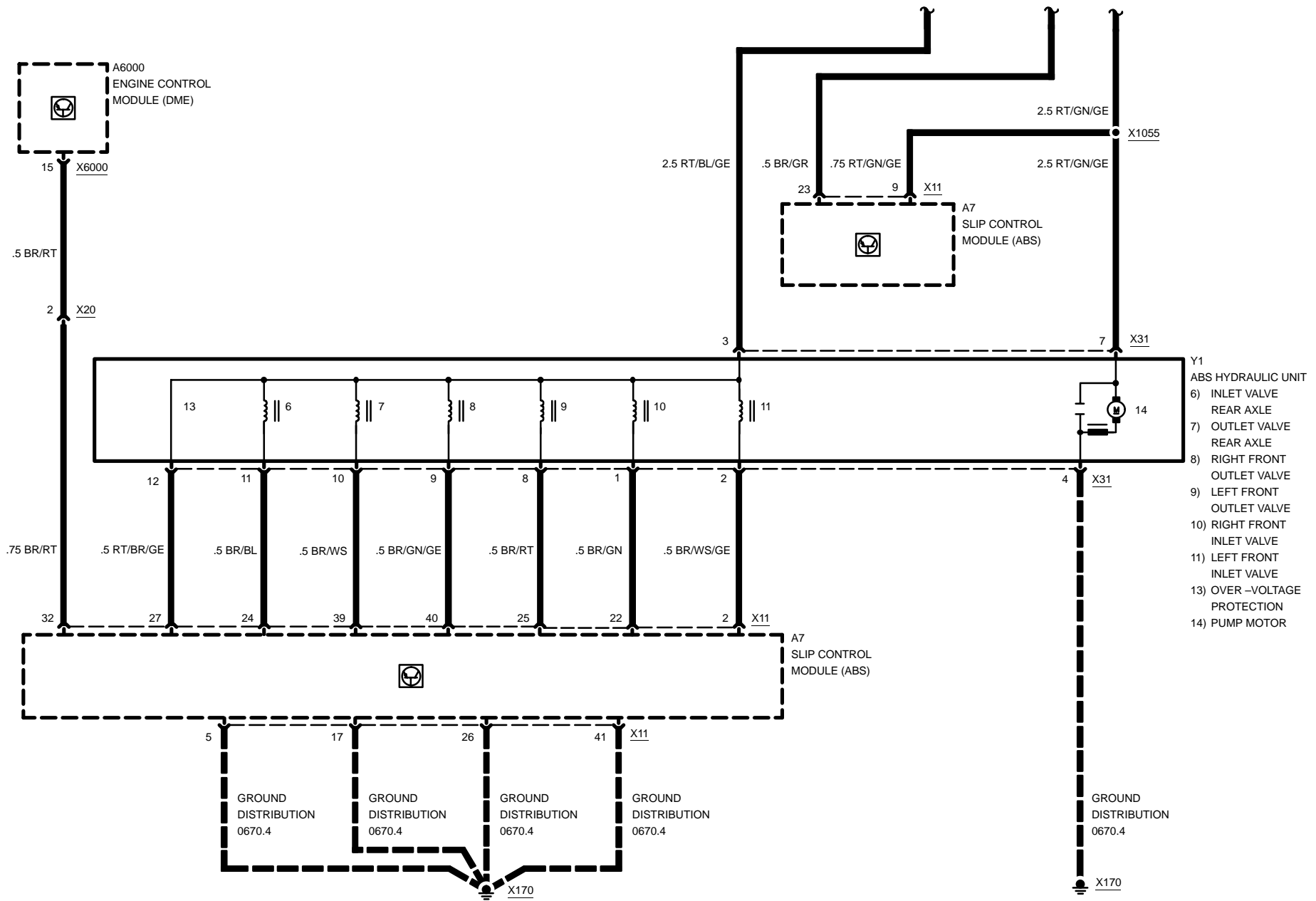

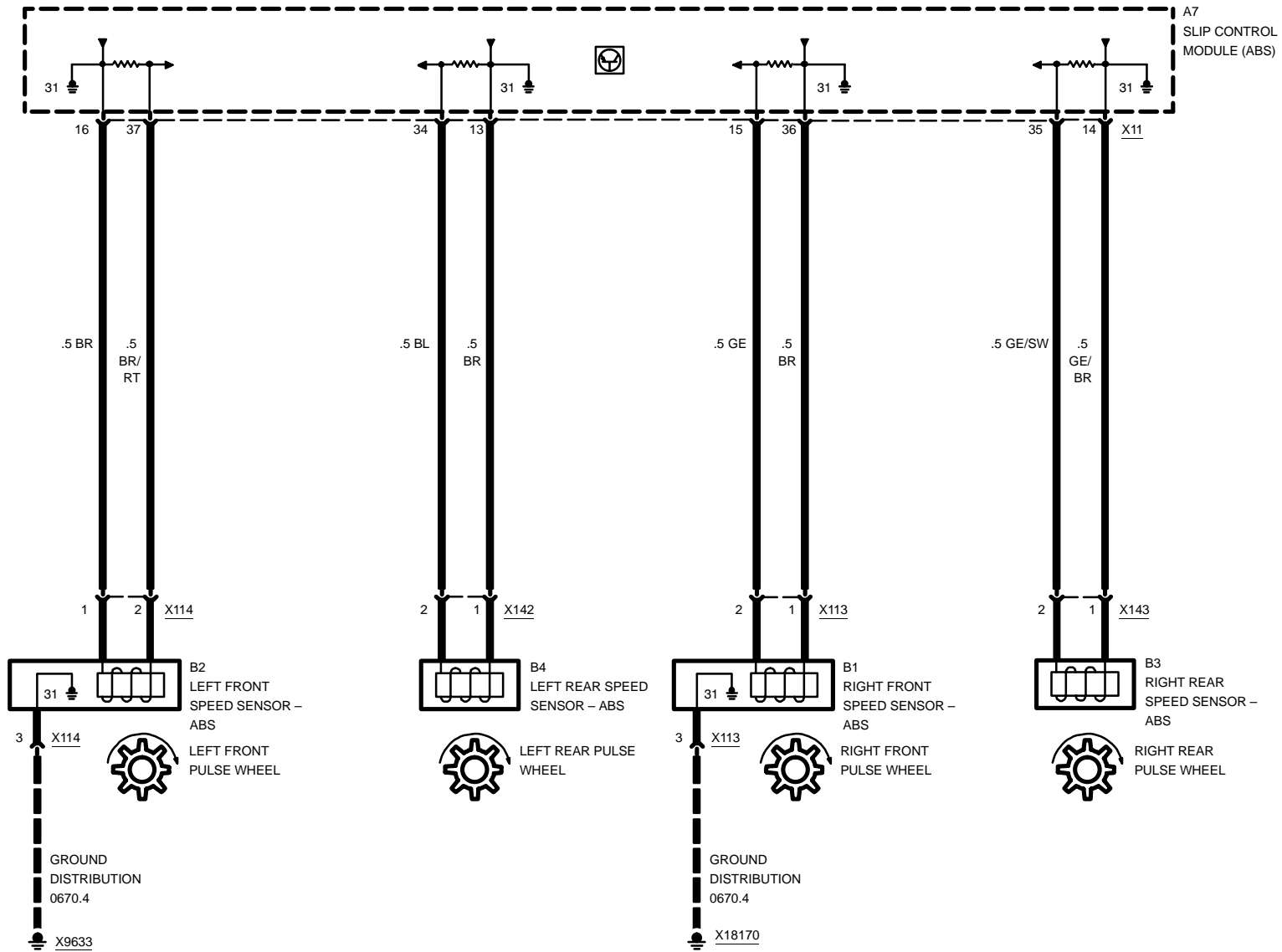

4-CYLINDER

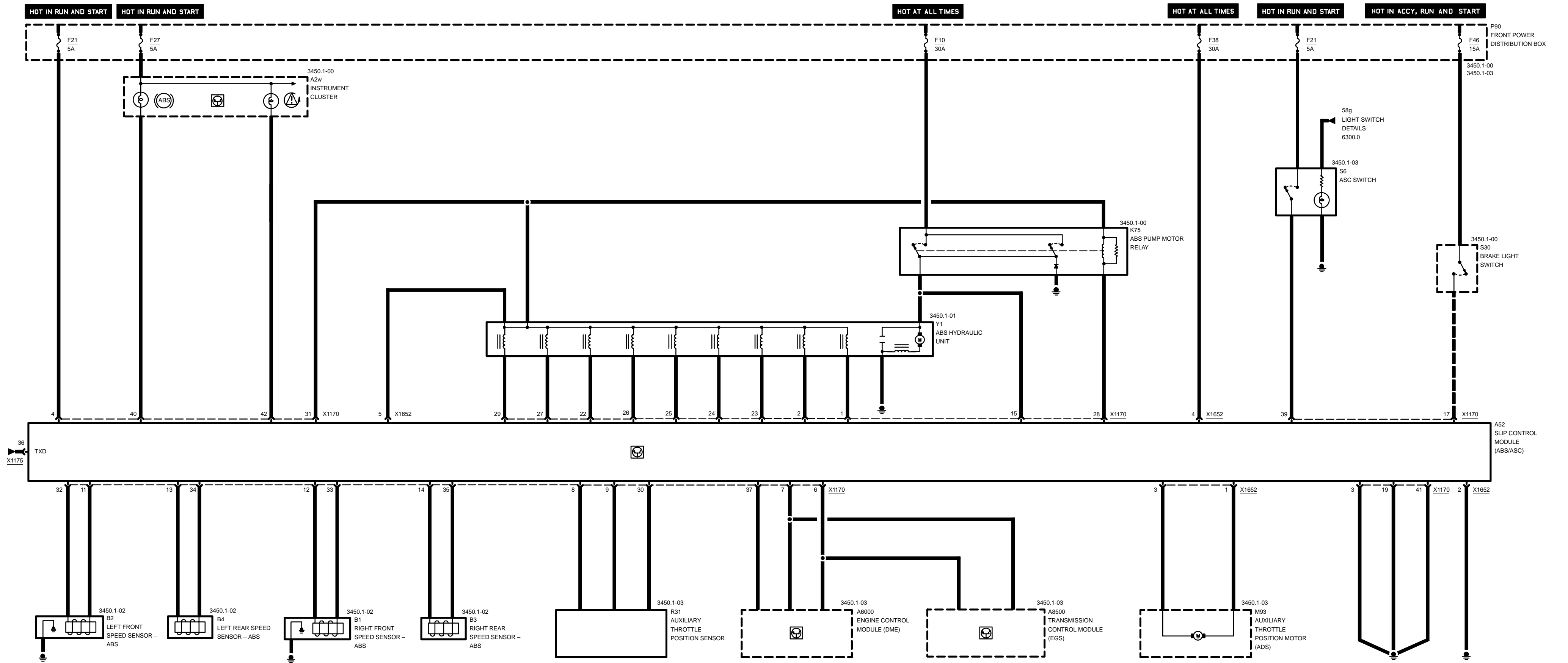

6-CYLINDER - Z3 ROADSTER

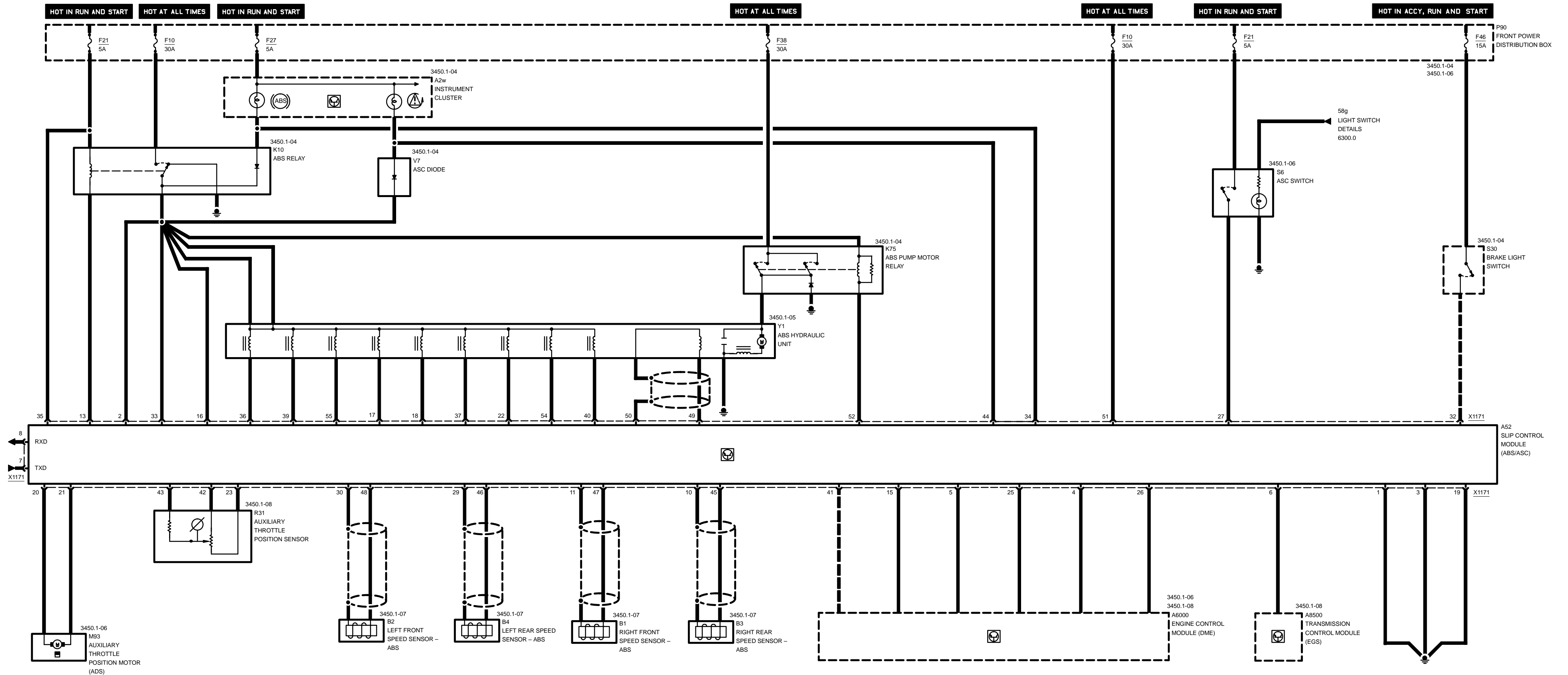

M ROADSTER

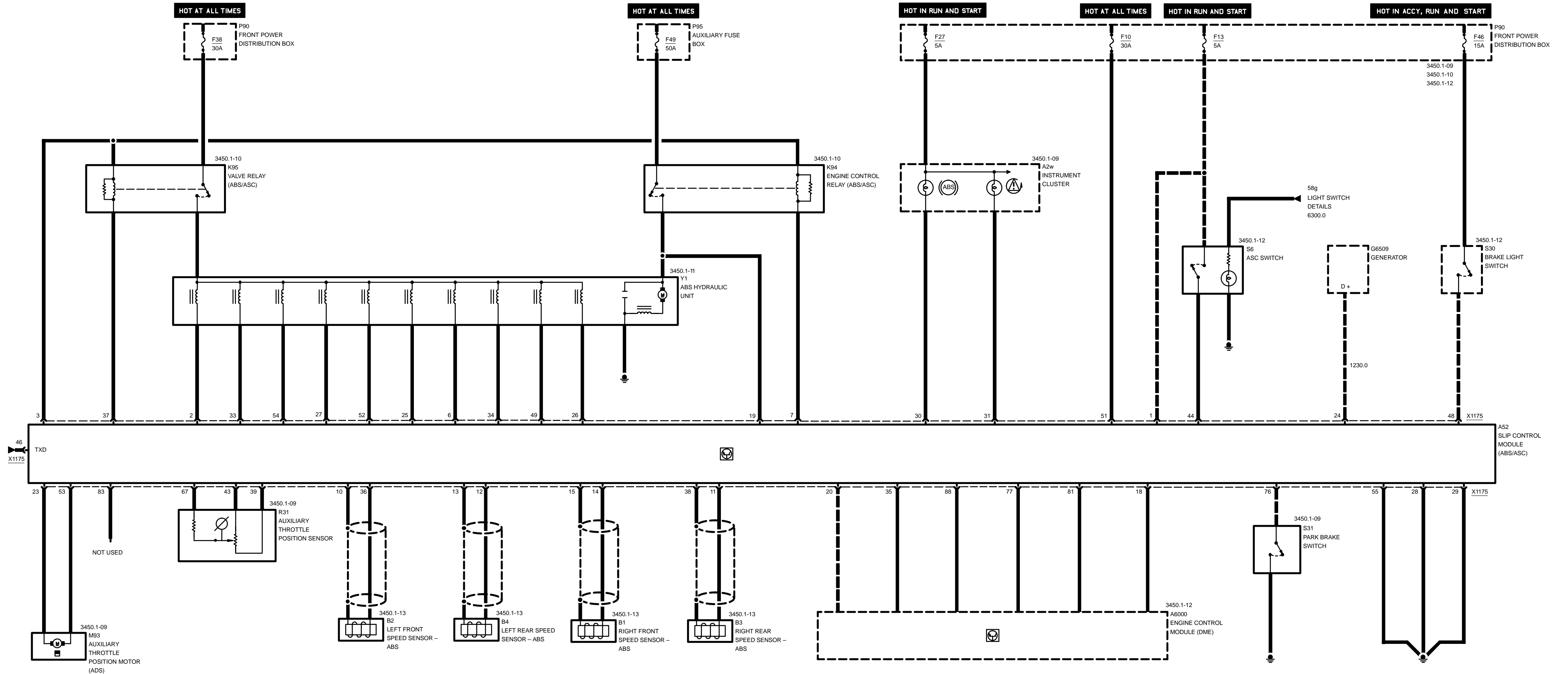

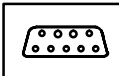

Z3

**Pin Assignments (4-Cylinder)****X1170**

Pin	Type	Description/Function	Connection
93	A	Left front inlet valve	ABS hydraulic unit
94	A	Left front outlet valve	ABS hydraulic unit
95	M	Ground	Ground point
96	E	Voltage supply	Fuse 21
97		Not used	
98	E/A	Can-Low	DME/EGS module
99	E/A	Can-High	DME/EGS module
100	E	Throttle position signal 1	Auxiliary throttle position sensor
101	E	Throttle position signal 3	Auxiliary throttle position sensor
102		Not used	
103	A	Sensor ground	Left front speed sensor (ABS)
104	A	Sensor ground	Right front speed sensor (ABS)
105	A	Sensor ground	Left rear speed sensor (ABS)
106	A	Sensor ground	Right rear speed sensor (ABS)
107	E	Signal, pump motor	ABS pump motor relay
108		Not used	
109	E	Brake pedal position	Brake light switch
110		Not used	
111	M	Ground	Ground point
112		Not used	
113		Not used	
114	A	Right rear outlet valve	ABS hydraulic unit
115	A	Right front inlet valve	ABS hydraulic unit
116	A	Right front outlet valve	ABS hydraulic unit
117	A	Left rear outlet valve	ABS hydraulic unit
118	A	Left rear inlet valve	ABS hydraulic unit
119	A	Right rear inlet valve	ABS hydraulic unit
120	A	Activate relay	ABS pump motor relay
121	A	Separator valve	ABS hydraulic unit
122	E	Throttle position signal 2	Auxiliary throttle position sensor

E = Input, A = Output, M = Ground

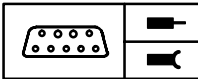

Z3

**Pin Assignments (4-Cylinder)**

Pin	Type	Description/Function	Connection
123	A	ABS signal	ABS pump motor relay/Hydraulic unit
124	E	Speed signal	Left front speed sensor (ABS)
125	E	Speed signal	Right front speed sensor (ABS)
126	E	Speed signal	Left rear speed sensor (ABS)
127	E	Speed signal	Right rear speed sensor (ABS)
128	E/A	TxD diagnostic data link	Data link connector
129	A	Right rear speed signal	DME module
130		Not used	
131	E	ASC signal	ASC switch
132	A	ABS signal	Instrument cluster
133	M	Ground	Ground point
134	A	ASC signal	Instrument cluster

X1652

Pin	Type	Description/Function	Connection
1	A	ADS step motor (-)	Auxiliary throttle position motor
2	M	Ground	Ground point
3	A	ADS step motor (+)	Auxiliary throttle position motor
4	E	Voltage supply	Fuse 38
5	A	ABS signal	ABS hydraulic unit

E = Input, A = Output, M = Ground

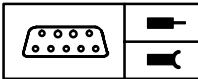

Z3

**Pin Assignments (6-Cylinder)****X1171**

Pin	Type	Description/Function	Connection
1	M	Ground	Ground point
2	E	Battery voltage	ABS relay
3	M	Ground, module	Ground point
4	E	Ignition cut-off signal	DME module
5	A	EML signal	DME module
6	A	Transmission influence	Transmission control module
7	E/A	TxD signal	Diagnostic link
8	A	RxD signal	Diagnostic link
9		Not used	
10	A	Sensor ground	Right rear speed sensor (ABS)
11	A	Sensor ground	Right front speed sensor (ABS)
12		Not used	
13	A	ABS power protection relay	ABS power protection relay
14		Not used	
15	A	Right rear speed signal	DME module
16	E	Current	ABS relay
17	A	Left rear solenoid valve signal	ABS hydraulic unit
18	A	Left rear solenoid valve signal	ABS hydraulic unit
19	M	Ground	Ground
20	A	ADS step motor (-)	ADS step motor
21	A	ADS step motor (+)	ADS step motor
22	A	Right front solenoid valve signal	ABS hydraulic unit
23	E	ASC throttle flap potentiometer (-)	ASC throttle flap motor potentiometer
24		Not used	
25	E	Signal idle speed	DME module
26	A	Throttle flap position	DME module
27	E	ASC switch signal	ASC switch
28		Not used	
29	A	Sensor ground	Left rear speed sensor (ABS)
30	A	Sensor ground	Left front speed sensor (ABS)

E = Input, A = Output, M = Ground

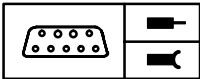

Z3

**Pin Assignments (6-Cylinder)**

Pin	Type	Description/Function	Connection
31		Not used	
32	E	Brake signal	Brake light switch
33	E	Plus supply	ABS protection relay
34	A	ABS lamp control	Instrument cluster
35	E	Ignition signal	Fuse 21
36	A	Solenoid valve	ABS hydraulic unit
37	A	Right front solenoid valve signal	ABS hydraulic unit
38		Not used	
39	A	Right rear solenoid valve signal	ABS hydraulic unit
40	A	Left front solenoid valve signal	ABS hydraulic unit
41	E	Speed signal	DME module
42	E	ASC throttle flap potentiometer (+)	ASC throttle flap potentiometer
43	E	ASC throttle flap signal	ASC throttle flap potentiometer
44	A	ASC lamp control	Instrument cluster
45	E	Right rear speed sensor signal	Right rear speed sensor
46	E	Left rear speed sensor signal	Left rear speed sensor
47	E	Right front speed sensor signal	Right front speed sensor
48	E	Left front speed sensor signal	Left front speed sensor
49	E	Pump motor sensor signal	ABS hydraulic unit
50	E	Shield pump motor sensor	ABS hydraulic unit
51	E	Plus supply	Front power distribution box, fuse 10
52	A	ABS pump motor relay	ABS pump motor relay
53		Not used	
54	A	Left front solenoid valve signal	ABS hydraulic unit
55	A	Left rear solenoid valve signal	ABS hydraulic unit

E = Input, A = Output, M = Ground

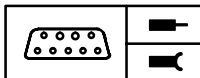

Z3

**Pin Assignments (M Roadster)****X1175**

Pin	Type	Description/Function	Connection
56	E	Voltage supply	Fuse 13
57	A	Left front inlet valve	ABS hydraulic unit
58	A	Voltage supply	Valve – Engine control relay
59		Not used	
60		Not used	
61	A	Right rear inlet valve	ABS hydraulic unit
62	A	Activare relay	Engine control relay
63		Not used	
64		Not used	
65	M	Sensor ground	Left front speed sensor (ABS)
66	E	Speed signal	Right rear speed sensor (ABS)
67	M	Sensor ground	Left rear speed sensor (ABS)
68	E	Speed signal	Left rear speed sensor (ABS)
69	M	Sensor ground	Right front speed sensor (ABS)
70	E	Speed signal	Right front speed sensor (ABS)
71		Not used	
72		Not used	
73	E	Engine signal 1	Engine control module (DME)
74	E	Relay activation feedback	Engine control relay
75	E	Speed signal	Engine control module (DME)
76		Not used	
77		Not used	
78	A	ADS step motor (+)	ADS step motor
79	E	Charge indicator	Generator
80	A	Left rear outlet valve	ABS hydraulic unit
81	A	Shut-off valve (ASC)	ABS hydraulic unit
82	A	Right front outlet valve	ABS hydraulic unit
83	M	Ground	Ground point
84	M	Ground	Ground point
85	A	ABS lamp control	Instrument cluster

E = Input, A = Output, M = Ground

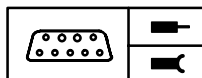

Z3

**Pin Assignments (M Roadster)**

Pin	Type	Description/Function	Connection
86	A	ASC lamp control	Instrument cluster
87		Not used	
88	A	Left front outlet valve	ABS hydraulic unit
89	A	Right rear outlet valve	ABS hydraulic unit
90	A	Right rear speed signal	Engine control module (DME)
91	E	Speed signal	Left front speed sensor (ABS)
92	A	Activate relay	Valve relay
93	M	Sensor ground	Right rear speed sensor (ABS)
94	A	Throttle position sensor (-)	Auxiliary throttle position sensor
95		Not used	
96		Not used	
97		Not used	
98	A	Throttle position sensor (+)	Auxiliary throttle position sensor
99	E	ASC-ON-signal	ASC switch
100		Not used	
101	E/A	TXD signal	Diagnostic link
102		Not used	
103	E	Brake signal	Brake light switch
104	A	Changeover valve (ASC)	ABS hydraulic unit
105		Not used	
106	E	Voltage supply	Fuse 10
107	A	Left rear inlet valve	ABS hydraulic unit
108	A	ADS step motor (-)	ADS step motor
109	A	Right front inlet valve	ABS hydraulic unit
110	M	Ground	Ground point
111		Not used	
112		Not used	
113		Not used	
114		Not used	
115		Not used	
116		Not used	
117		Not used	

E = Input, A = Output, M = Ground

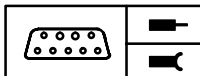

Z3

**Pin Assignments (M Roadster)**

Pin	Type	Description/Function	Connection
118		Not used	
119		Not used	
120		Not used	
121		Not used	
122	E	ASC throttle flap signal	Auxiliary throttle position sensor
123		Not used	
124		Not used	
125		Not used	
126		Not used	
127		Not used	
128		Not used	
129		Not used	
130		Not used	
131	E	Signal park brake set	Park brake switch
132	E	Engine signal 3	Engine control module (DME)
133		Not used	
134		Not used	
135		Not used	
136	E	Engine signal 2	Engine control module (DME)
137		Not used	
138	E	Transmission control signal	Not used
139		Not used	
140		Not used	
141		Not used	
142		Not used	
143	E	Throttle flap position	Engine control module (DME)

E = Input, A = Output, M = Ground



SLIP CONTROL (ABS/ASC)

4-CYLINDER

Z3

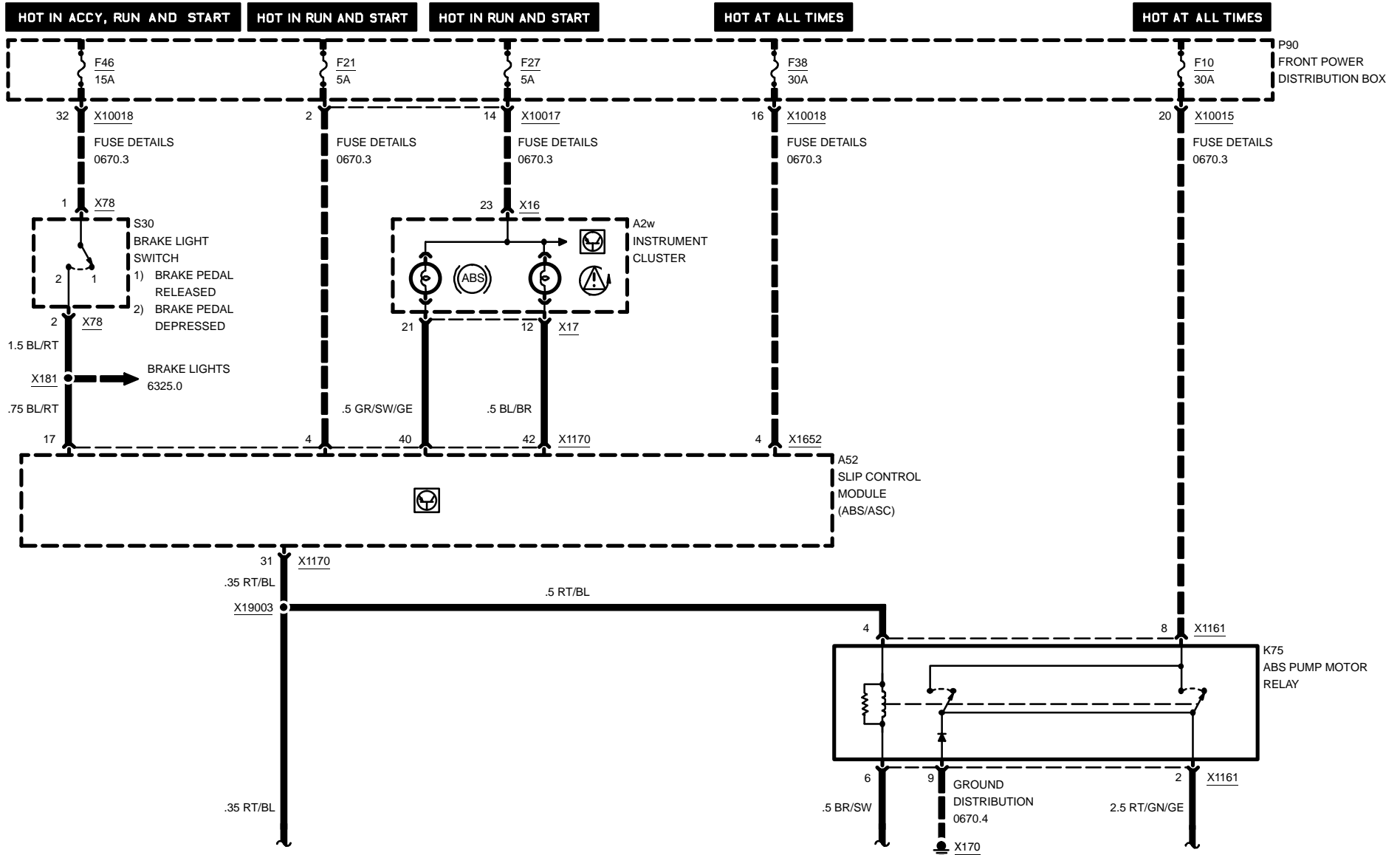

04/99

3450.1-00

1998

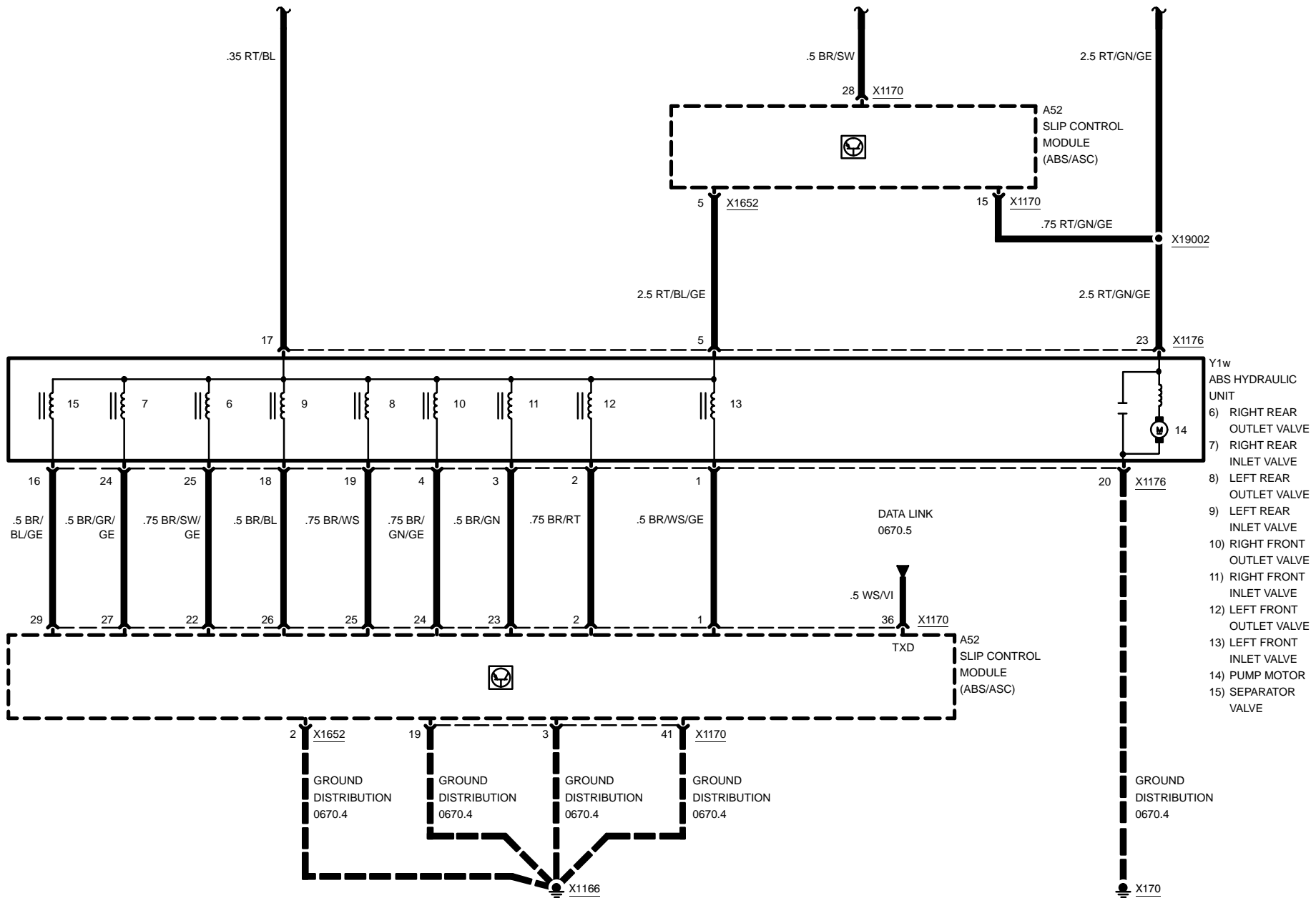



SLIP CONTROL (ABS/ASC)

4-CYLINDER

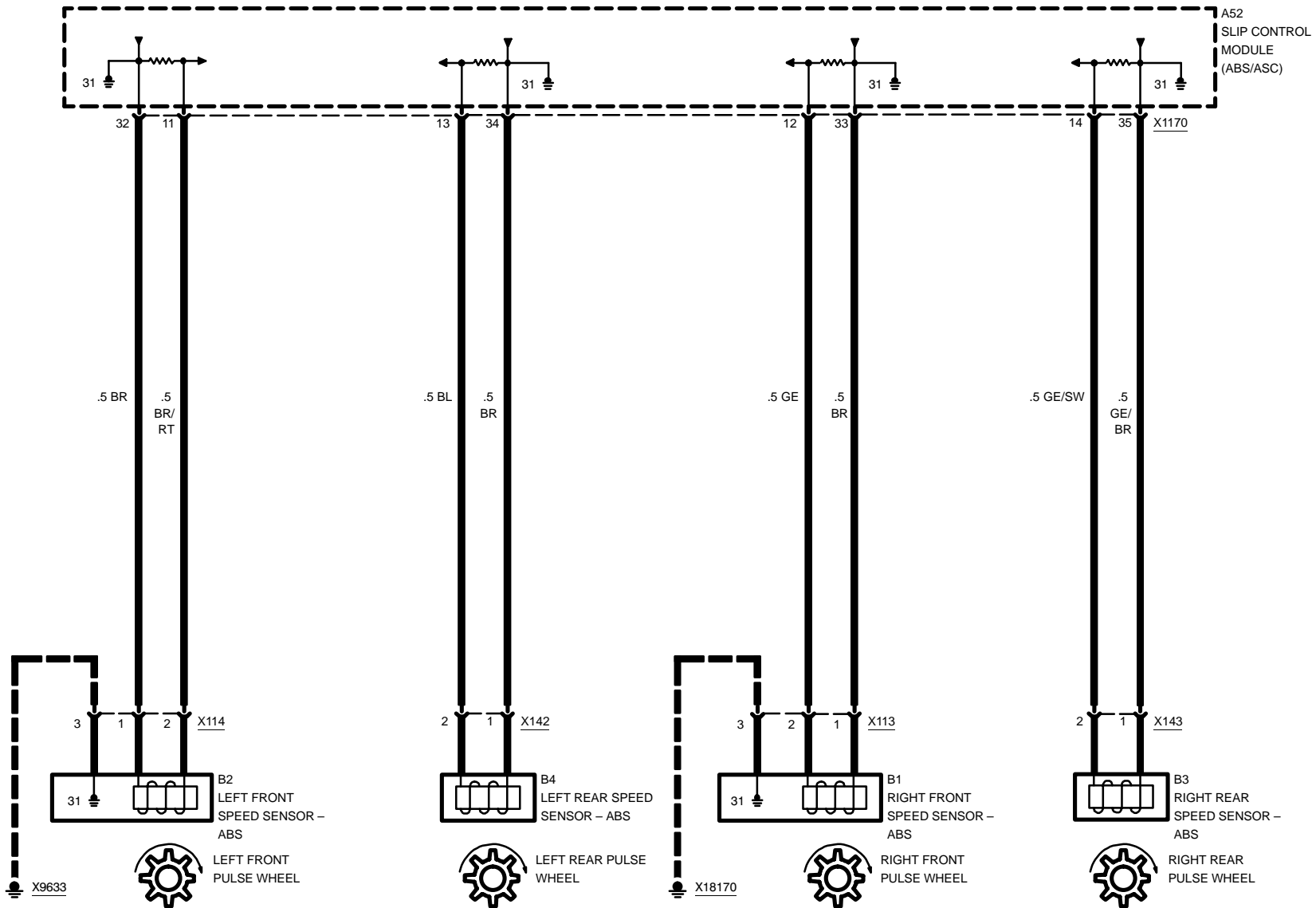



SLIP CONTROL (ABS/ASC)

4-CYLINDER

Z3

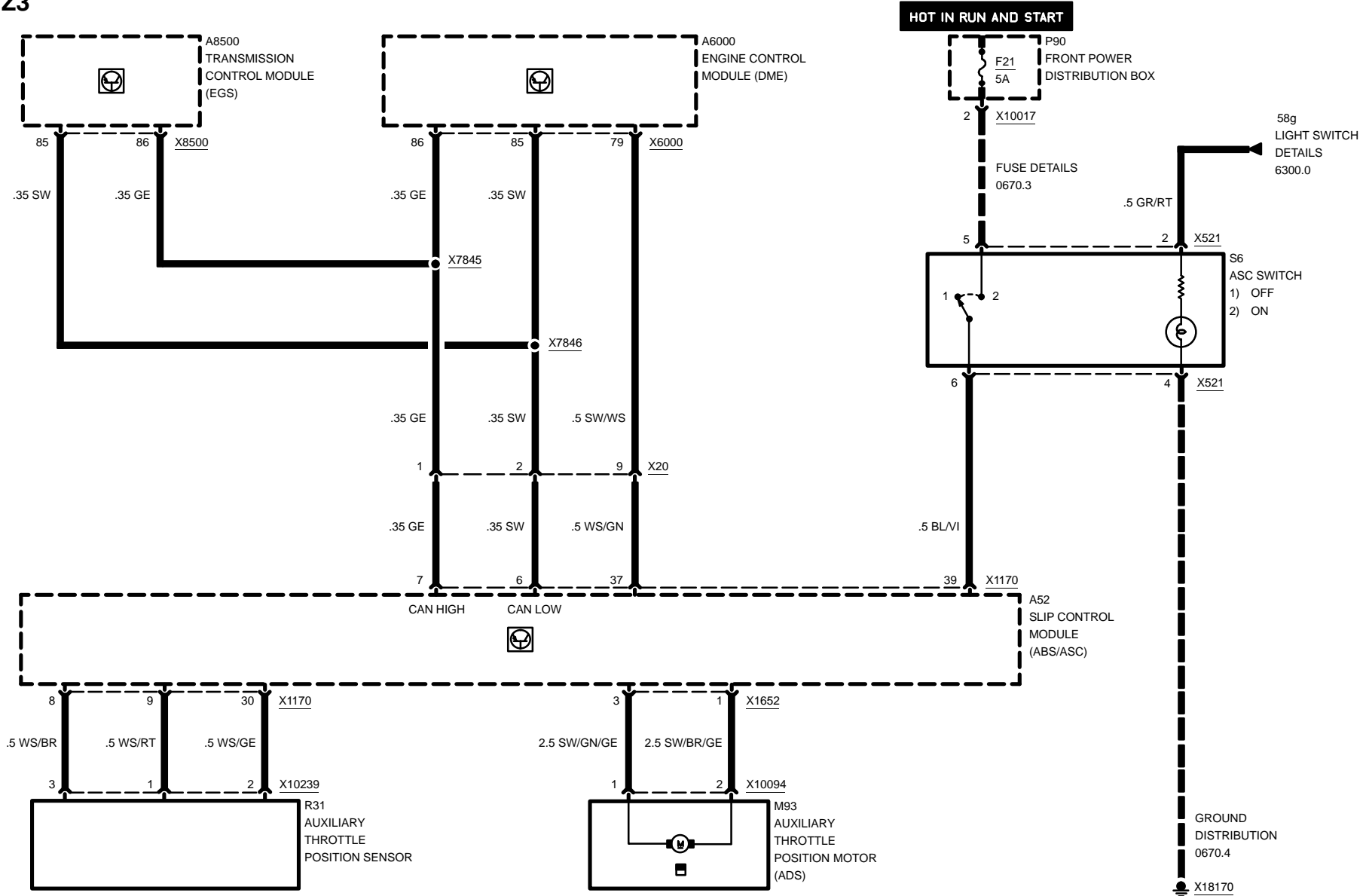

04/99

3450.1-03

1998



SLIP CONTROL (ABS/ASC)

Z3 ROADSTER 6-CYLINDER

Z3

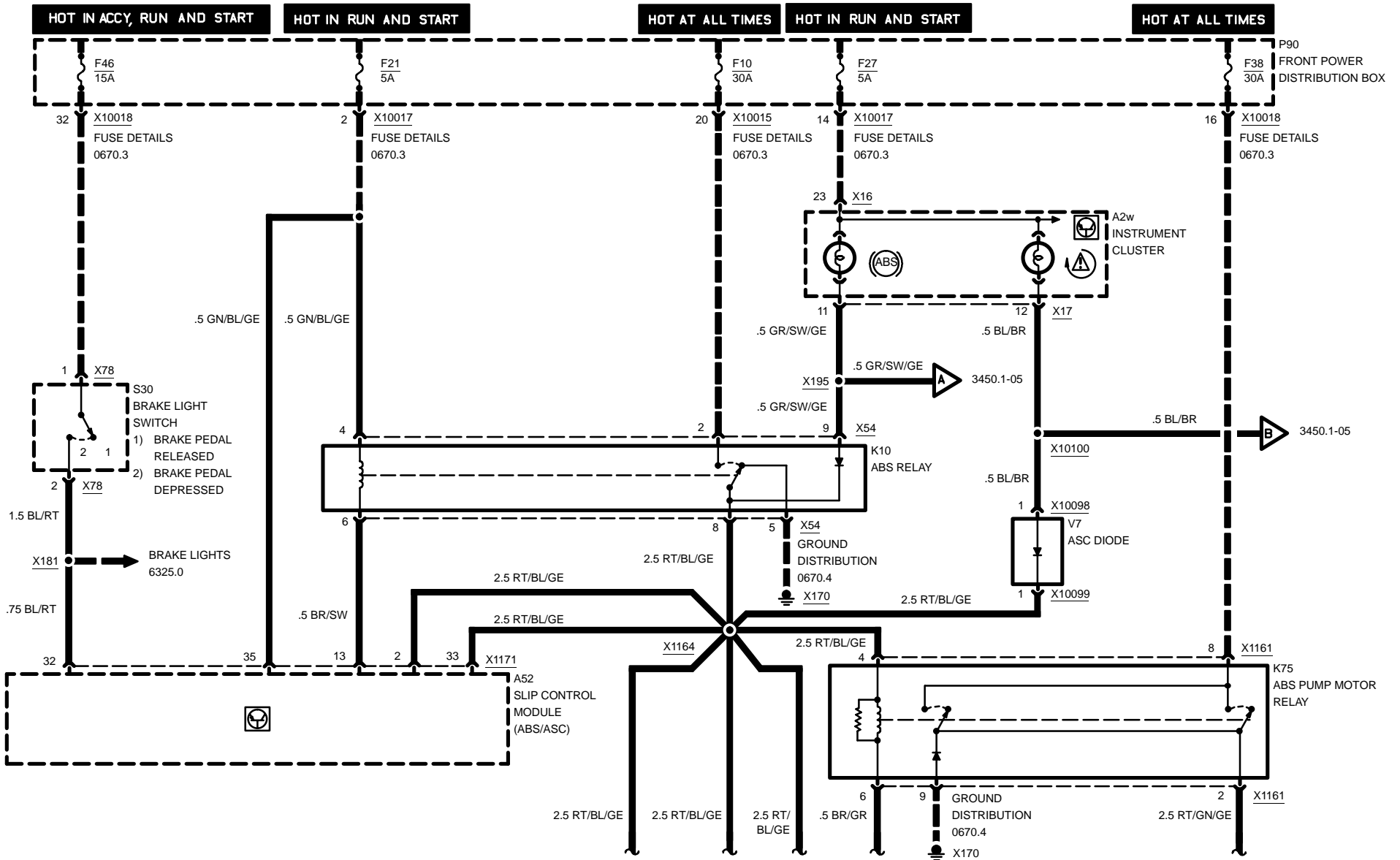

04/99

3450.1-04

1998

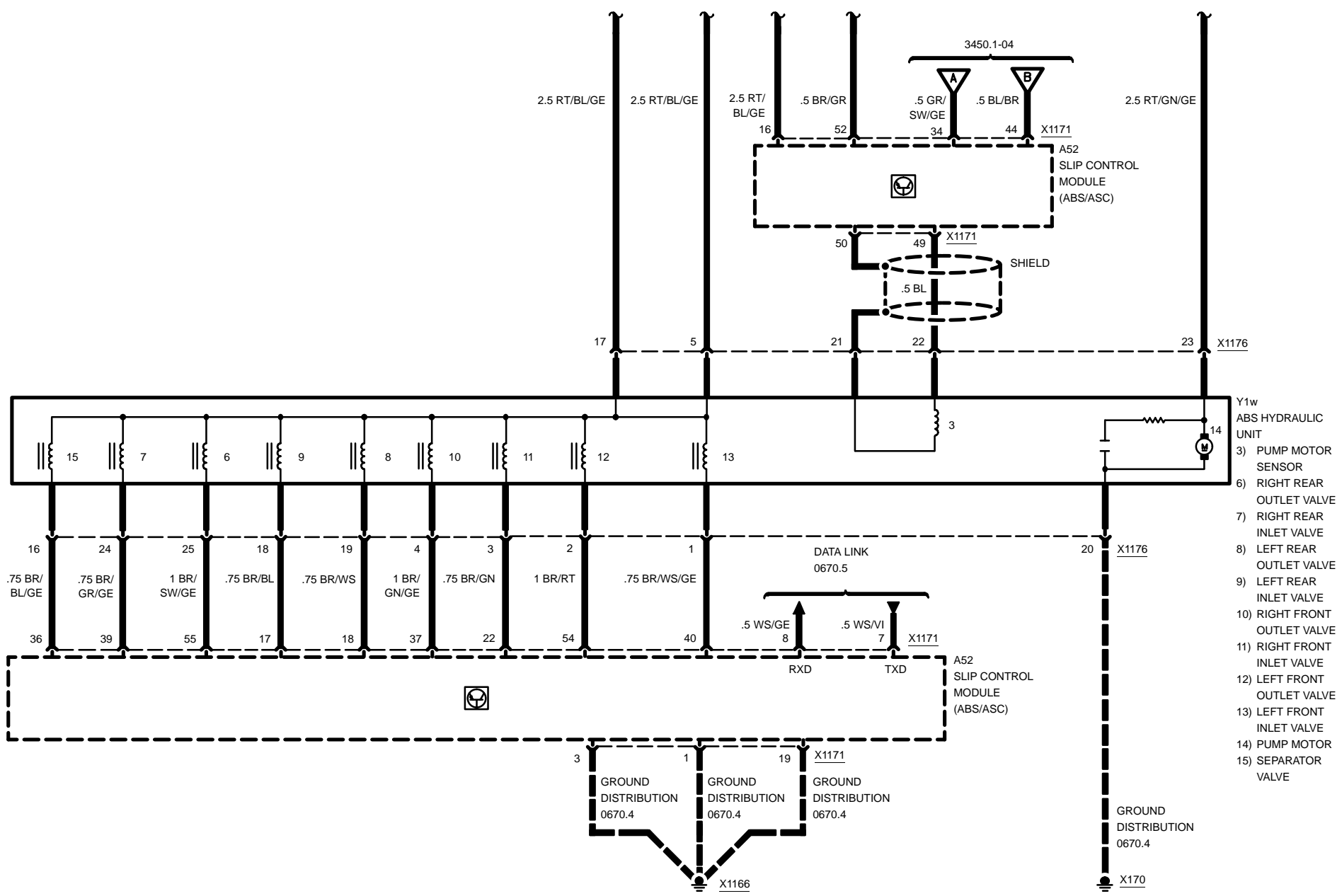

- Y1w
- ABS HYDRAULIC UNIT
- 3) PUMP MOTOR SENSOR
- 6) RIGHT REAR OUTLET VALVE
- 7) RIGHT REAR INLET VALVE
- 8) LEFT REAR OUTLET VALVE
- 9) LEFT REAR INLET VALVE
- 10) RIGHT FRONT OUTLET VALVE
- 11) RIGHT FRONT INLET VALVE
- 12) LEFT FRONT OUTLET VALVE
- 13) LEFT FRONT INLET VALVE
- 14) PUMP MOTOR
- 15) SEPARATOR VALVE

SLIP CONTROL (ABS/ASC)

Z3 ROADSTER 6-CYLINDER

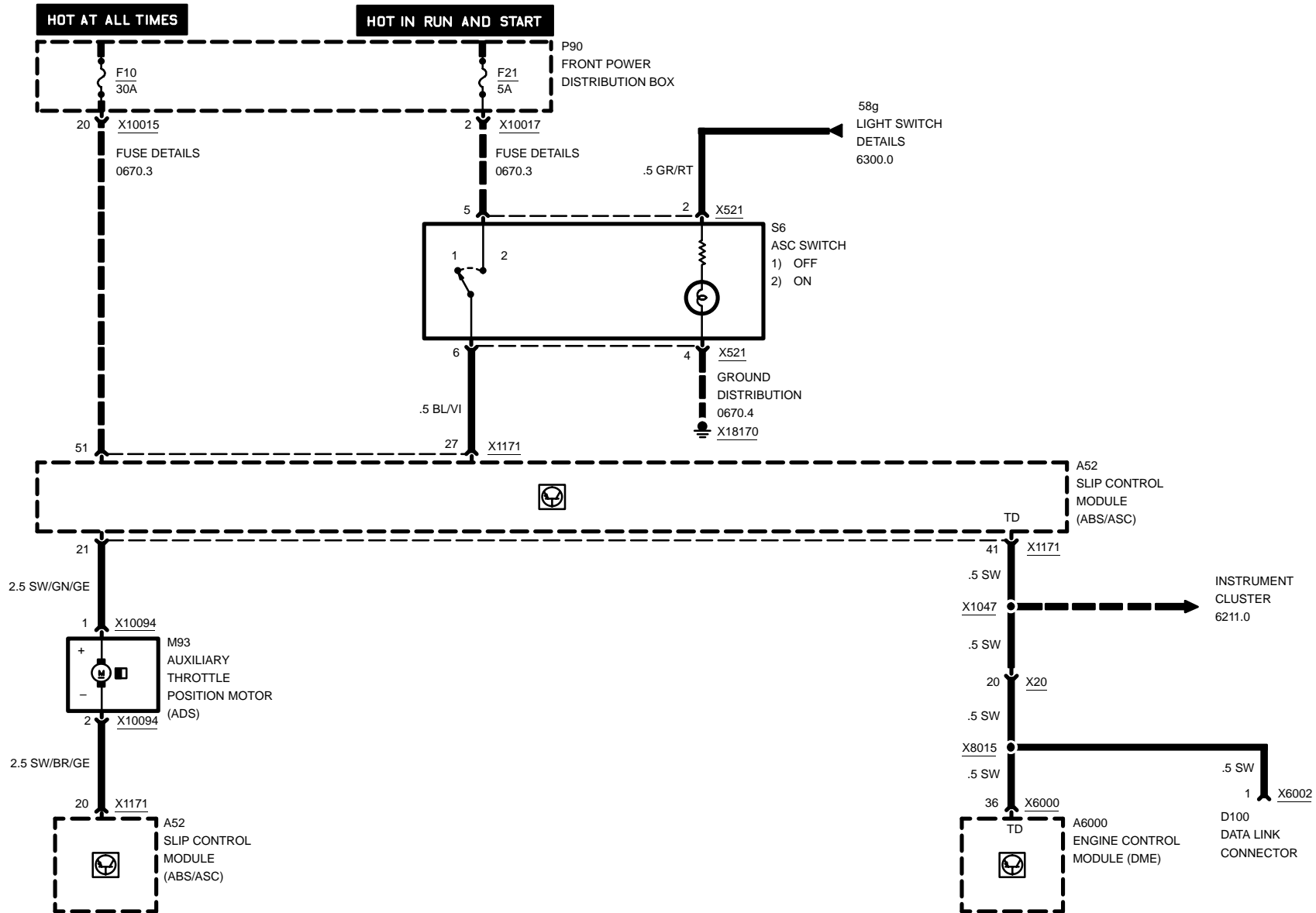

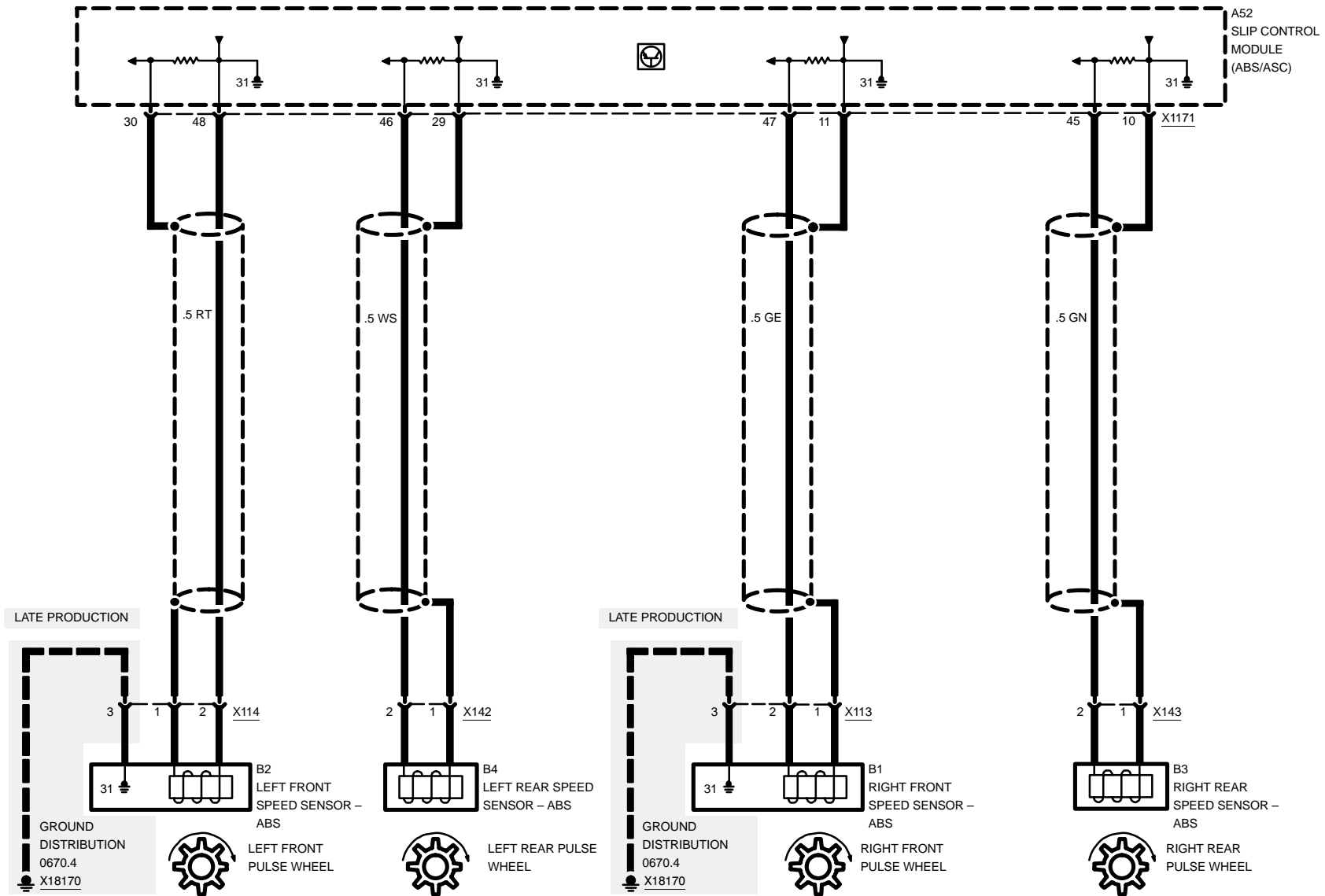



SLIP CONTROL (ABS/ASC)

Z3 ROADSTER 6-CYLINDER

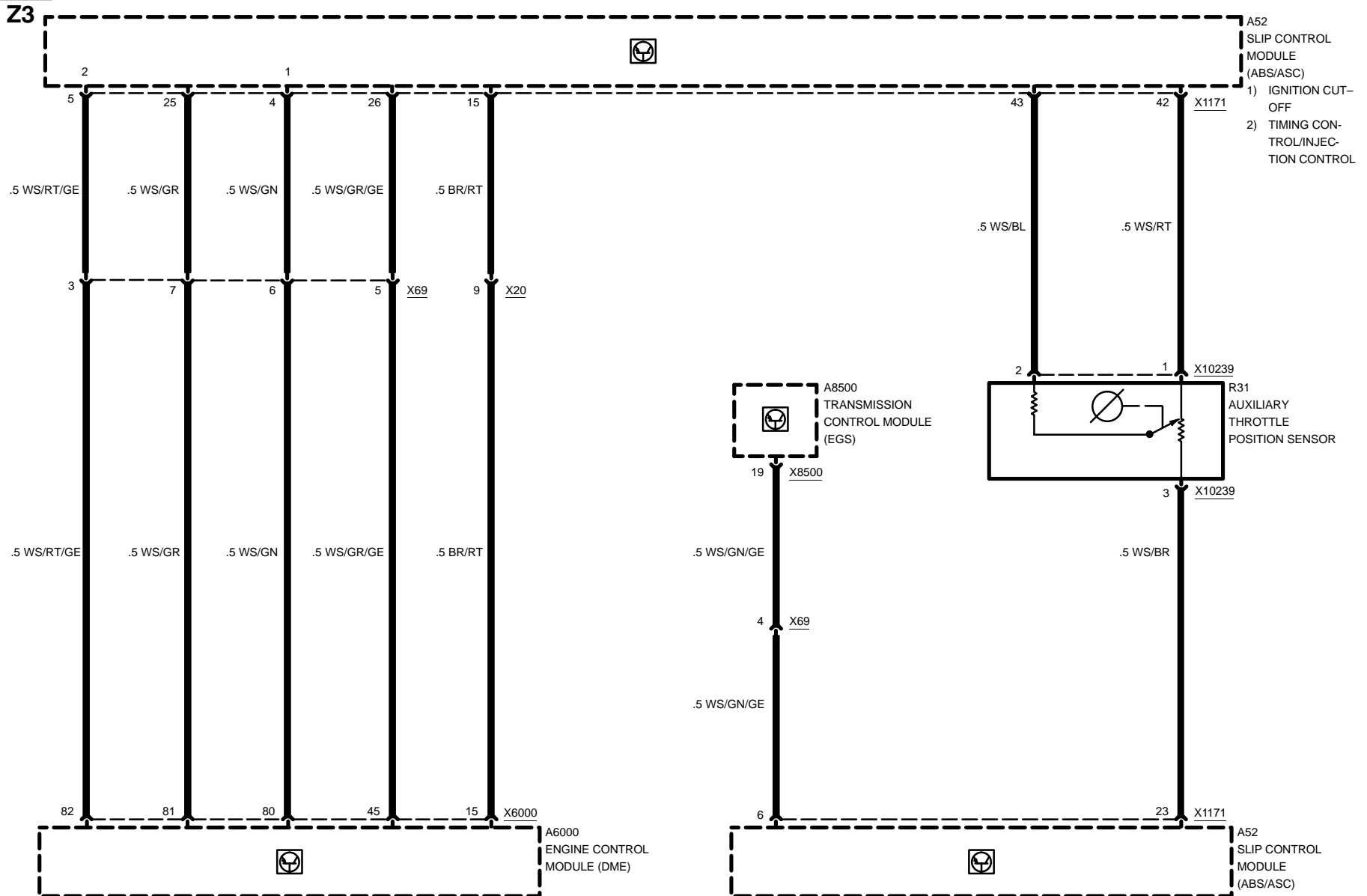



Z3

SLIP CONTROL (ABS/ASC)

M ROADSTER

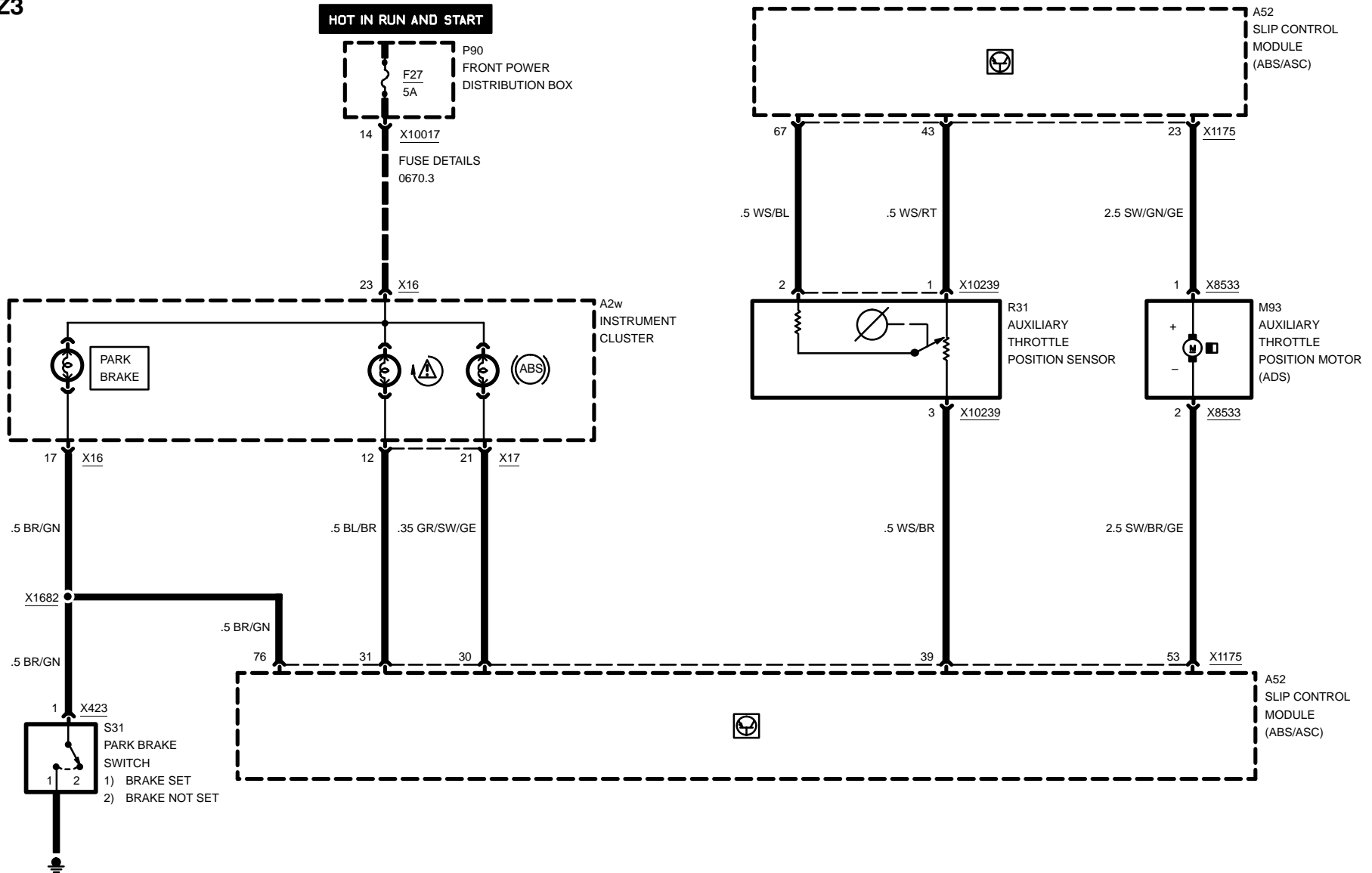

04/99

3450.1-09

1998



SLIP CONTROL (ABS/ASC)

M ROADSTER

Z3

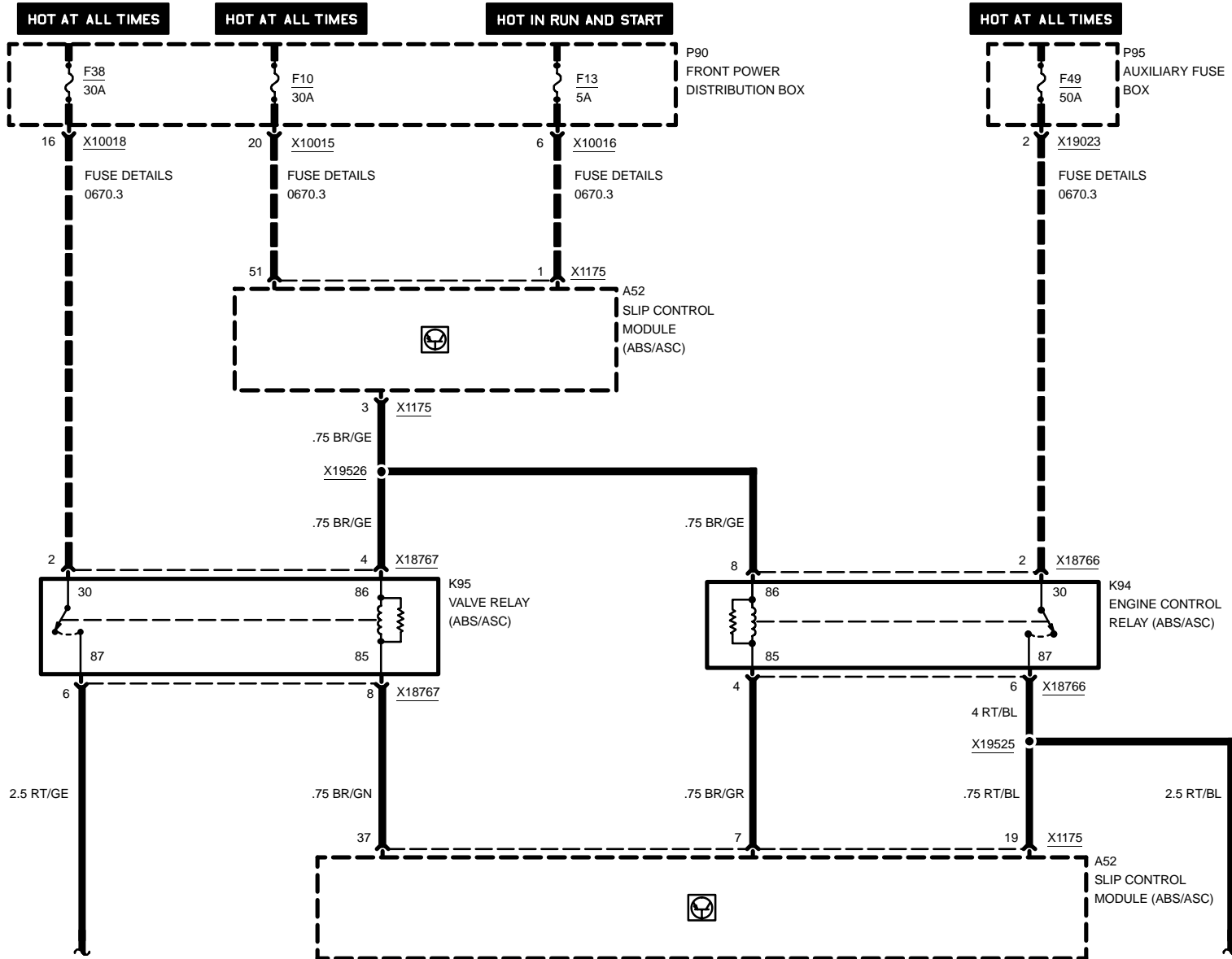

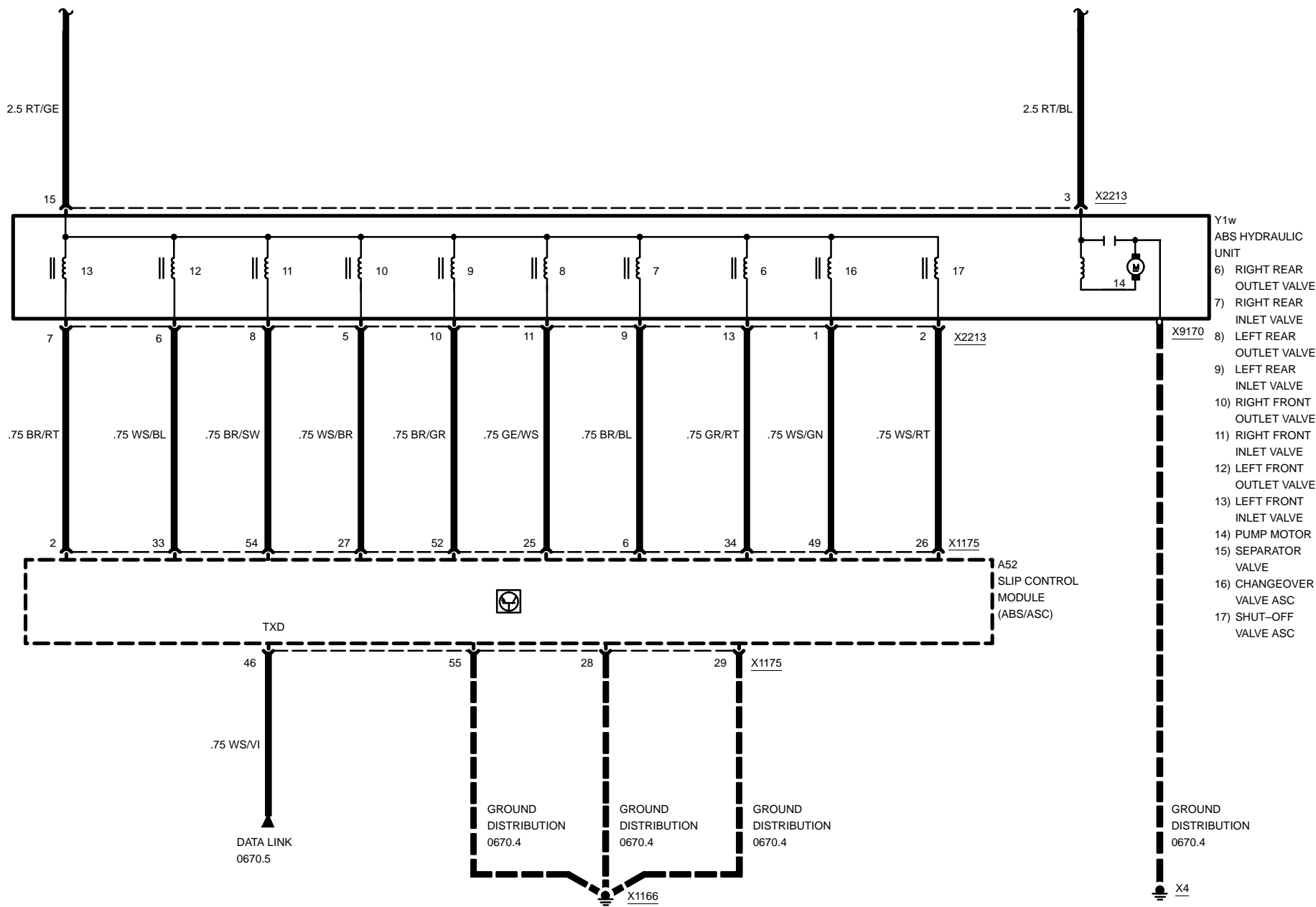



SLIP CONTROL (ABS/ASC)

M ROADSTER

Z3

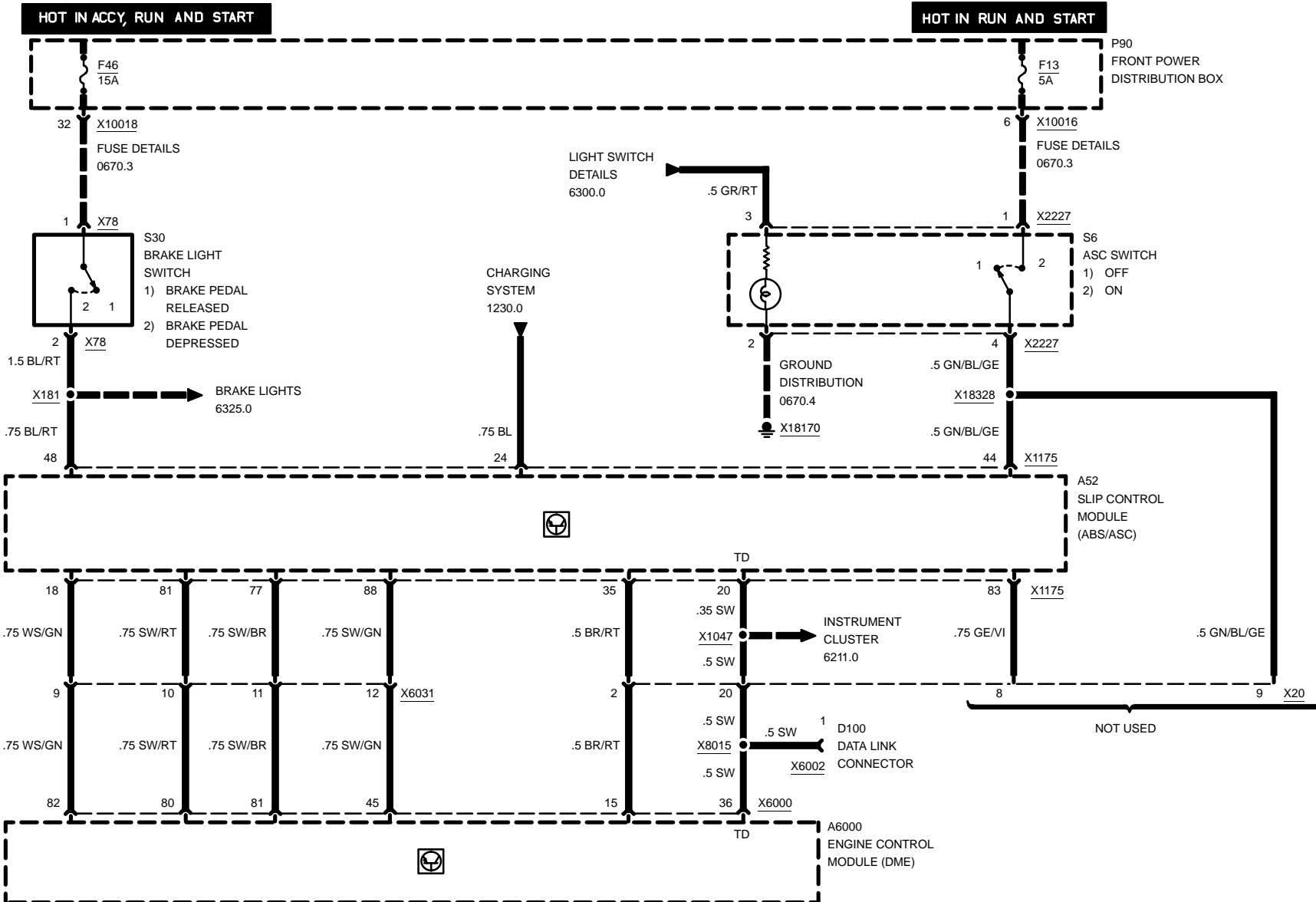

04/99

3450.1-12

1998

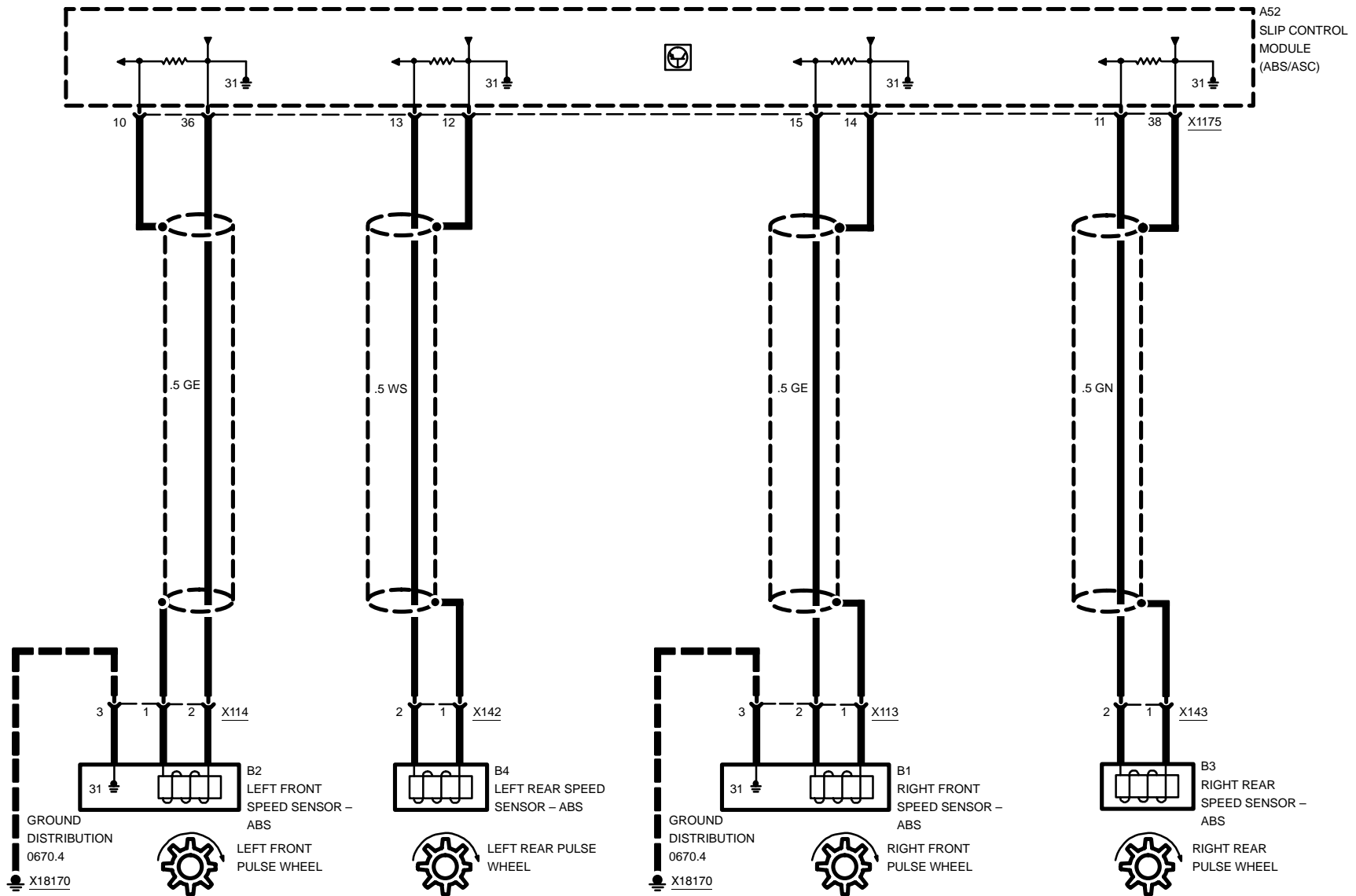

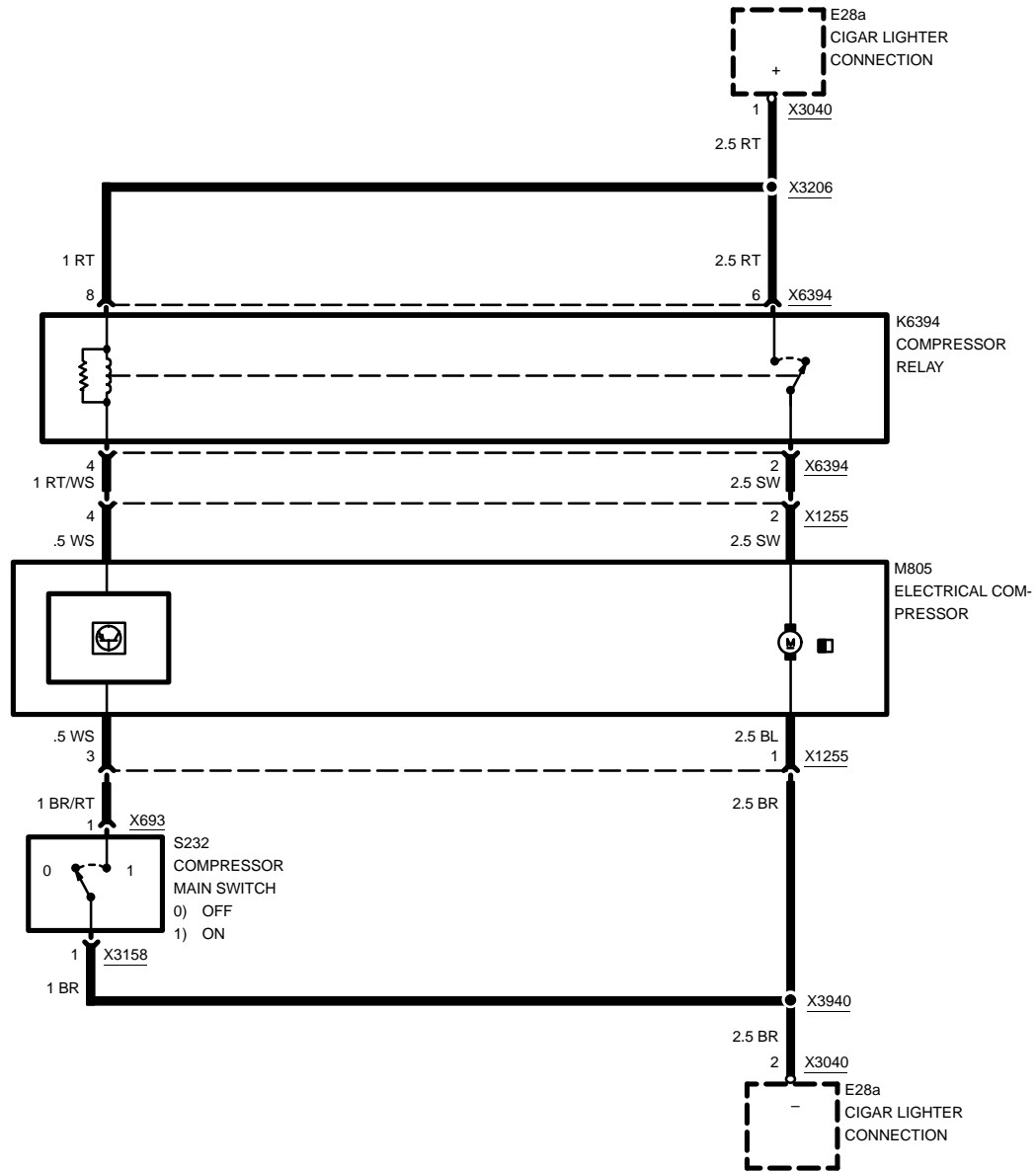



5116.0 POWER MIRRORS

OUTSIDE MIRROR

HOT IN RUN AND START

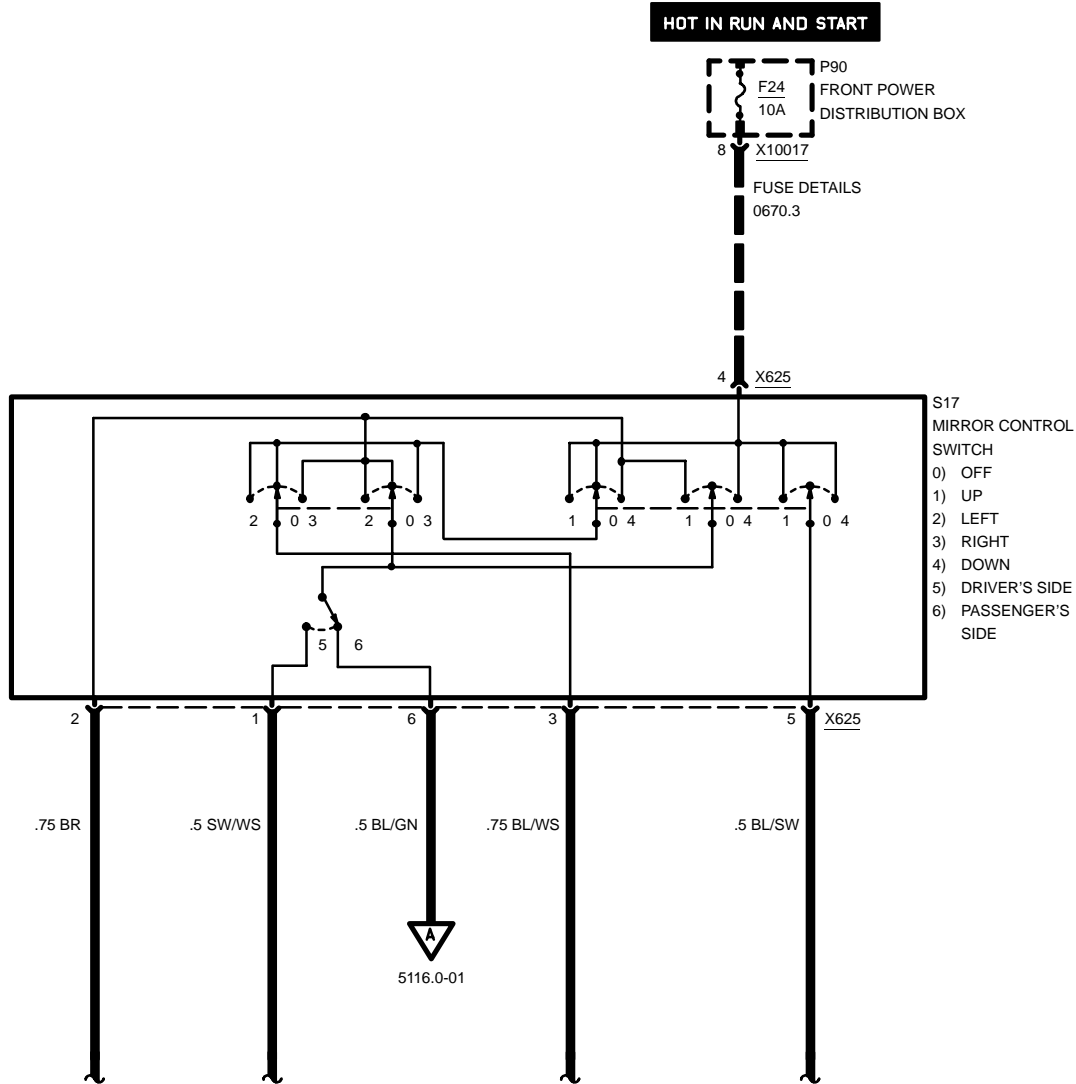

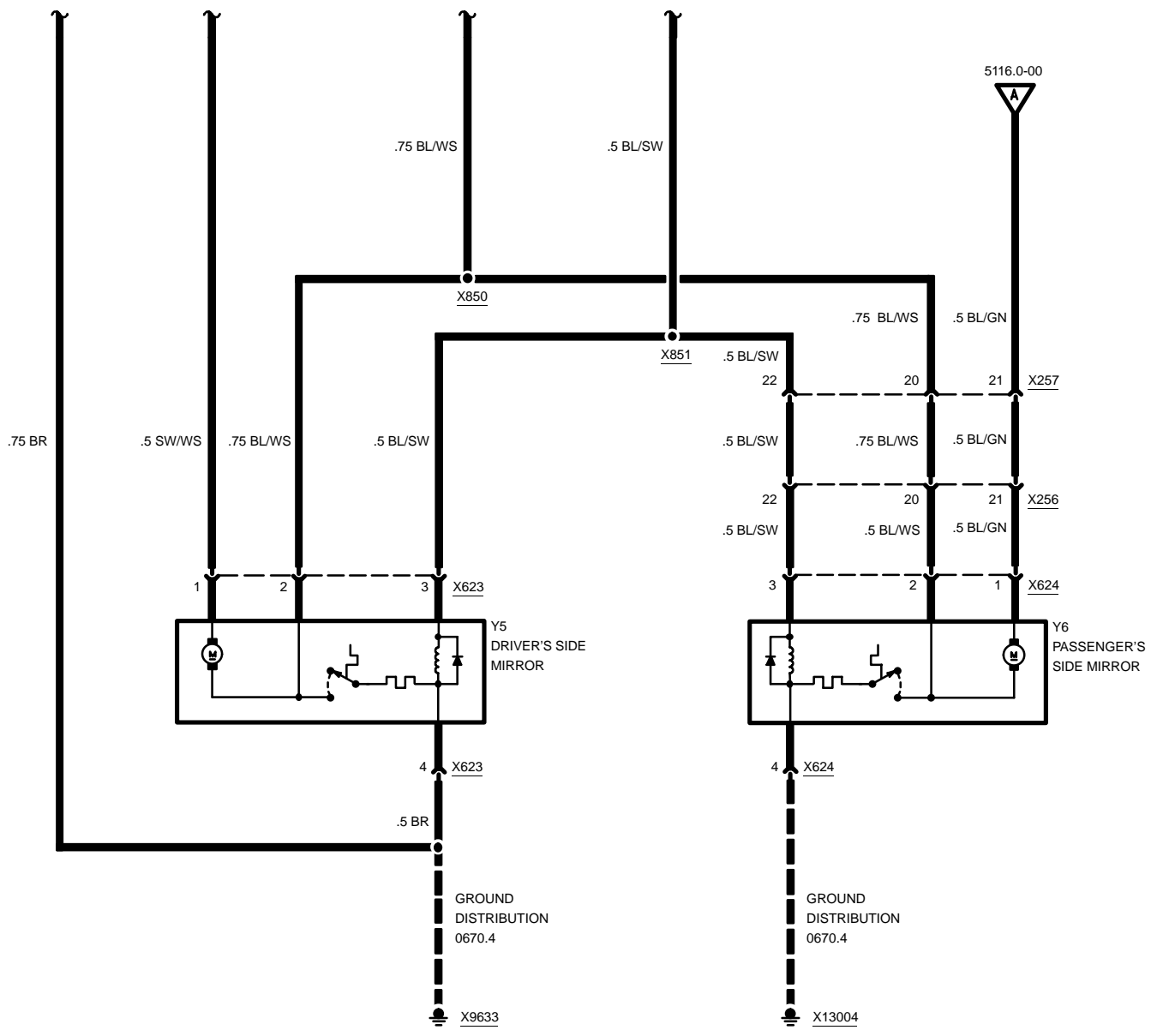

5126.0 ZKE CENTRAL LOCKING (ZV) INPUTS, DRIVE-AWAY PROTECTION

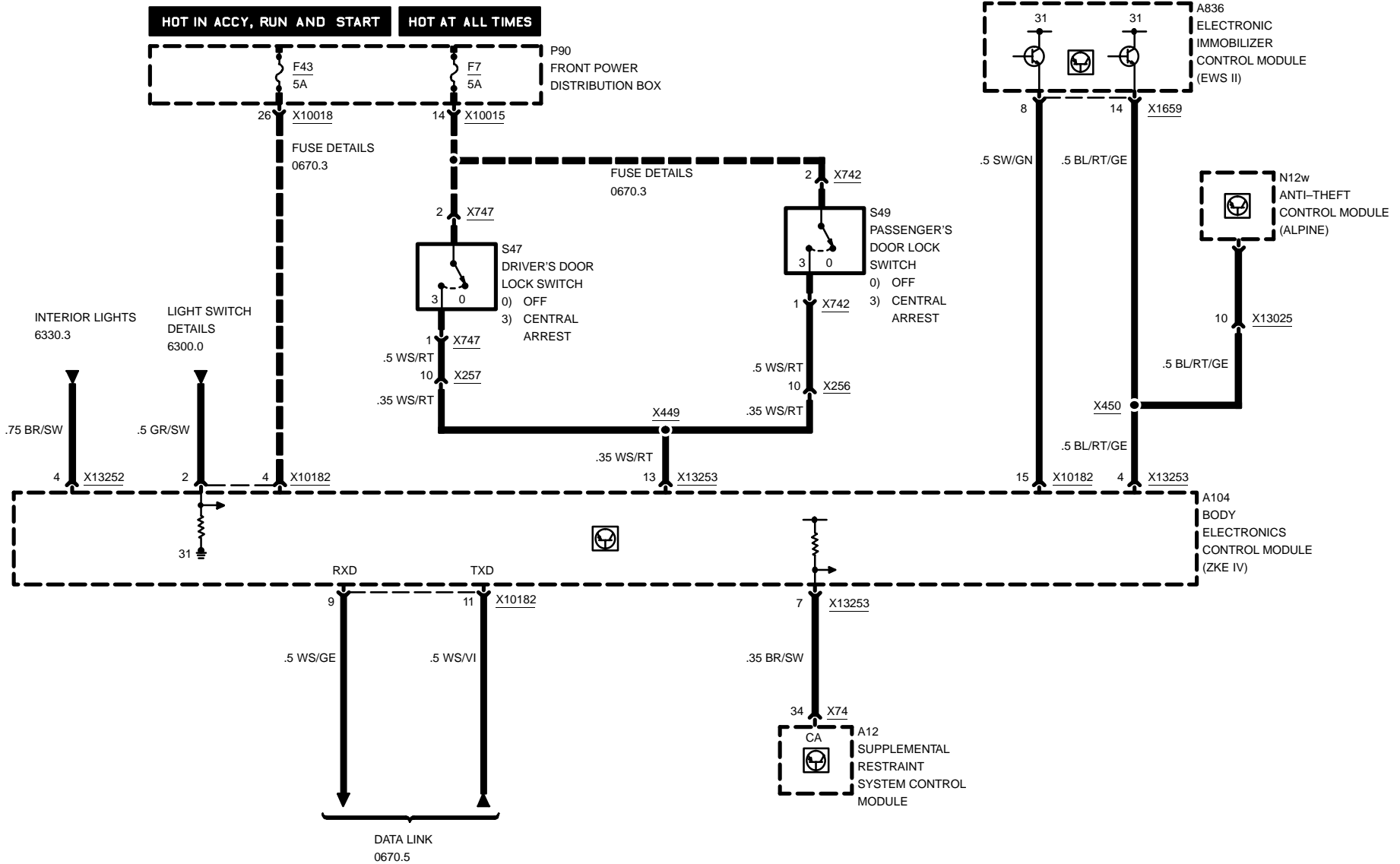



ZKE CENTRAL LOCKING (ZV)

INPUT DETAILS

Z3

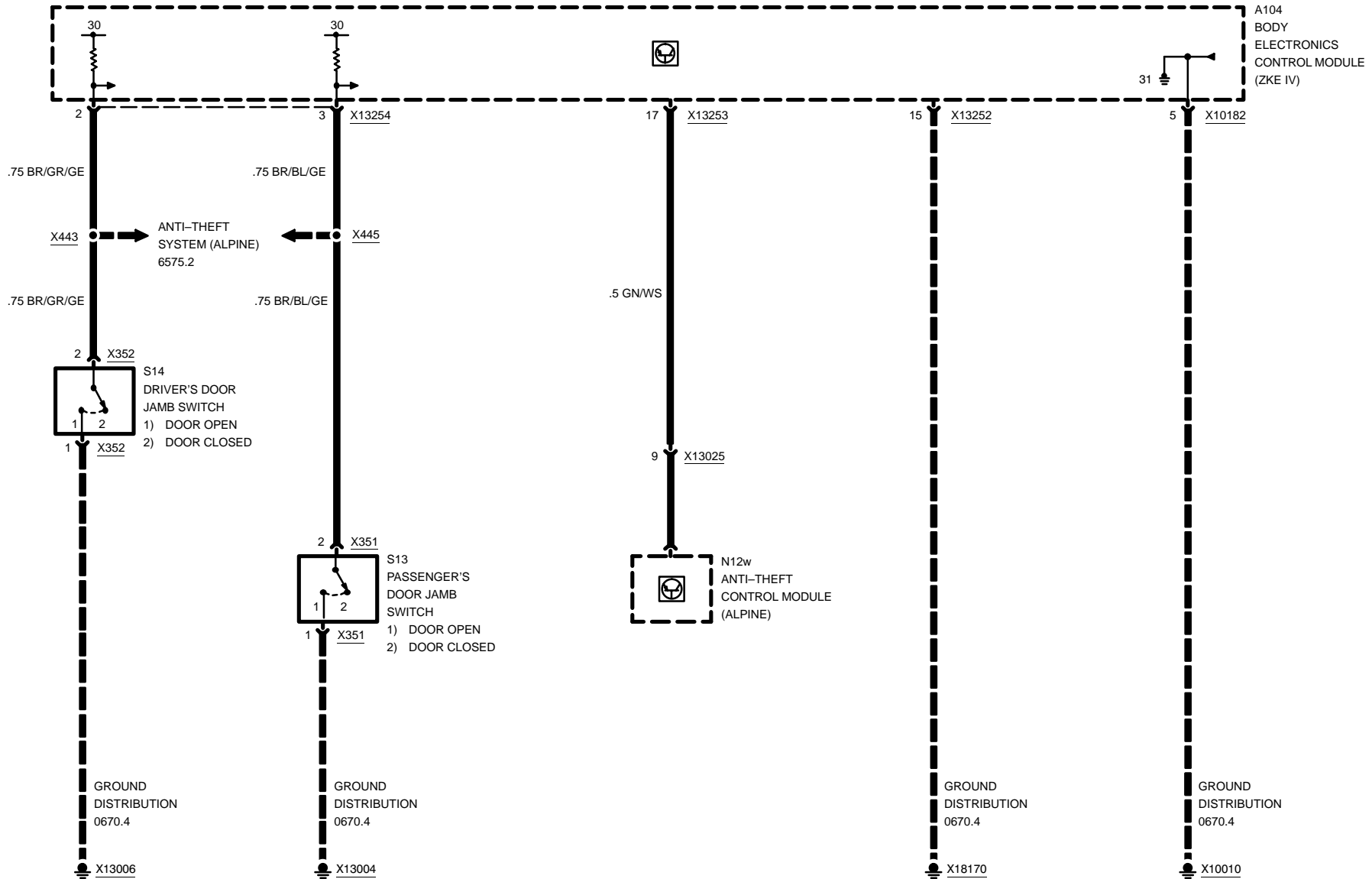

ZKE CENTRAL LOCKING (ZV)

OUTPUT DETAILS

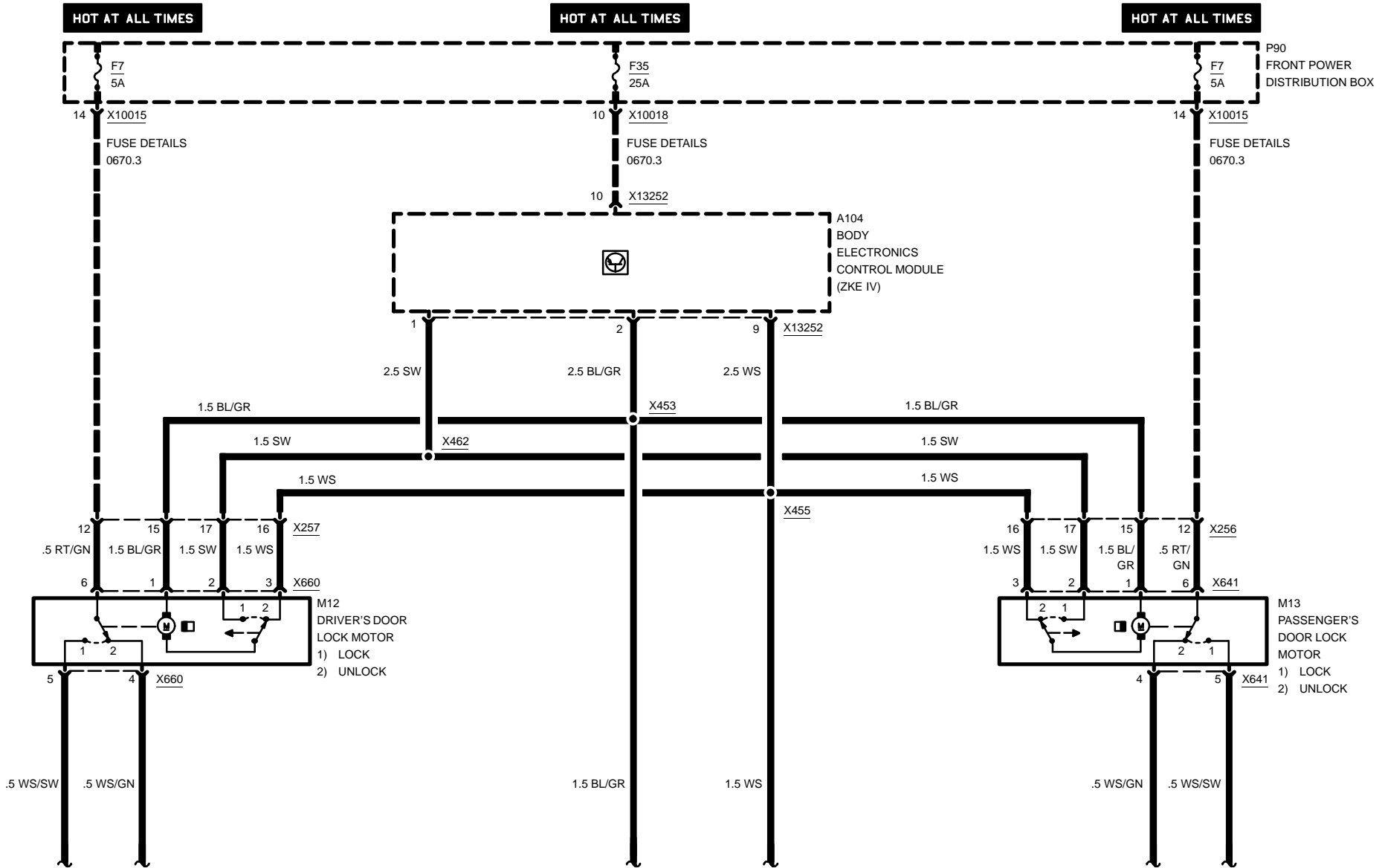

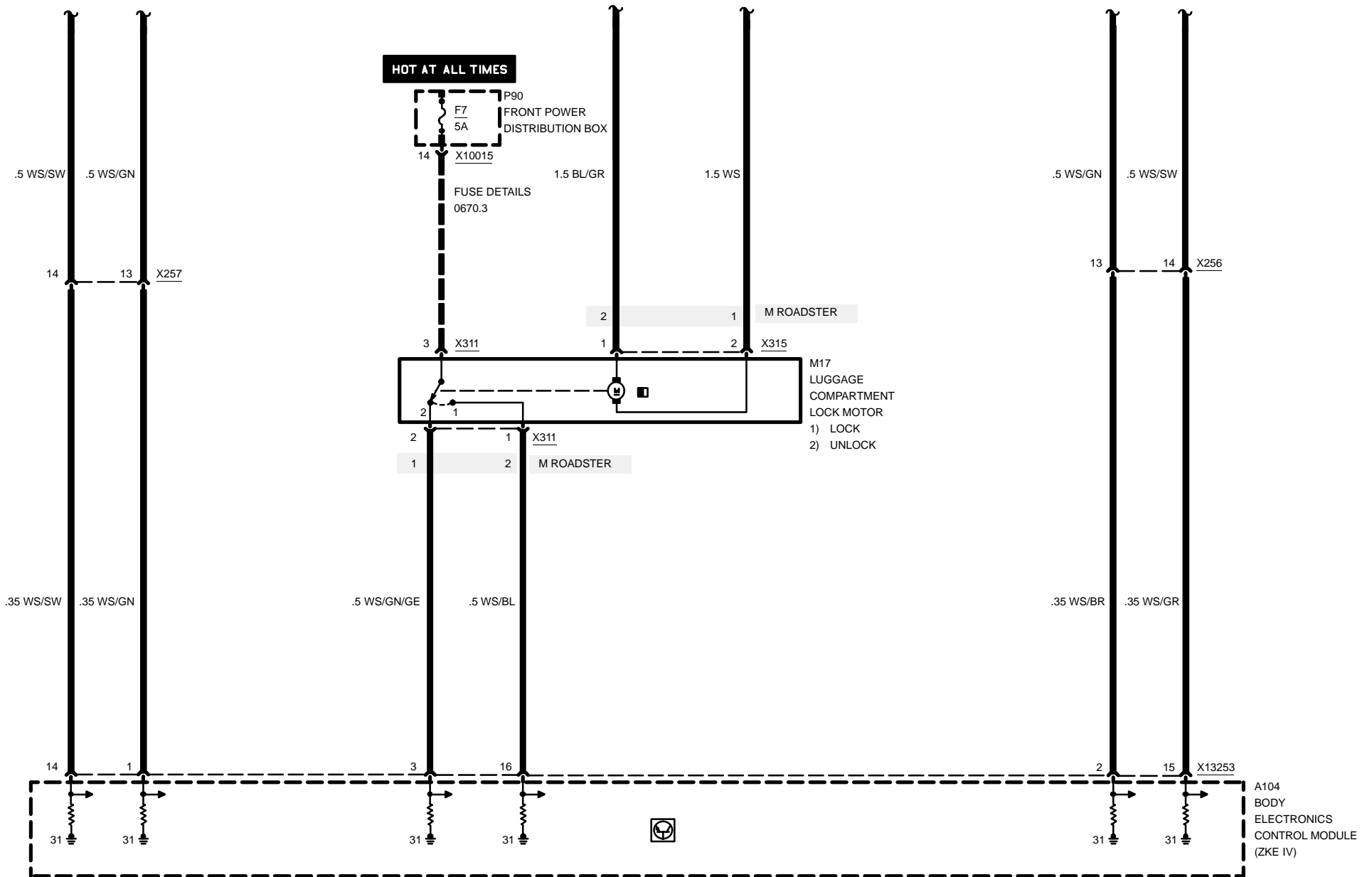



5133.0 ZKE POWER WINDOWS (FH)

INPUT DETAILS

04/99

5133.0-00

1998

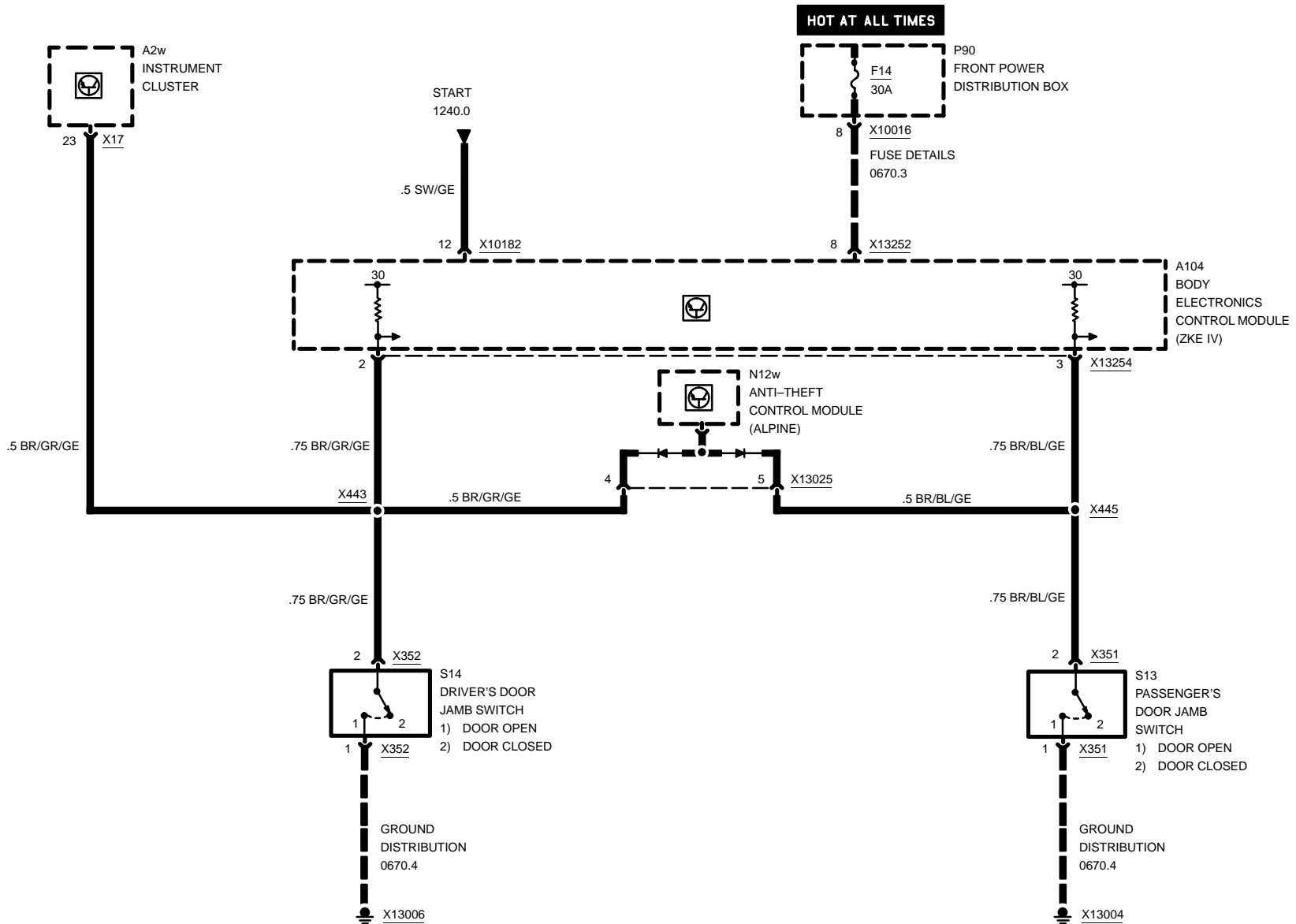



ZKE POWER WINDOWS (FH)

INPUT DETAILS

Z3

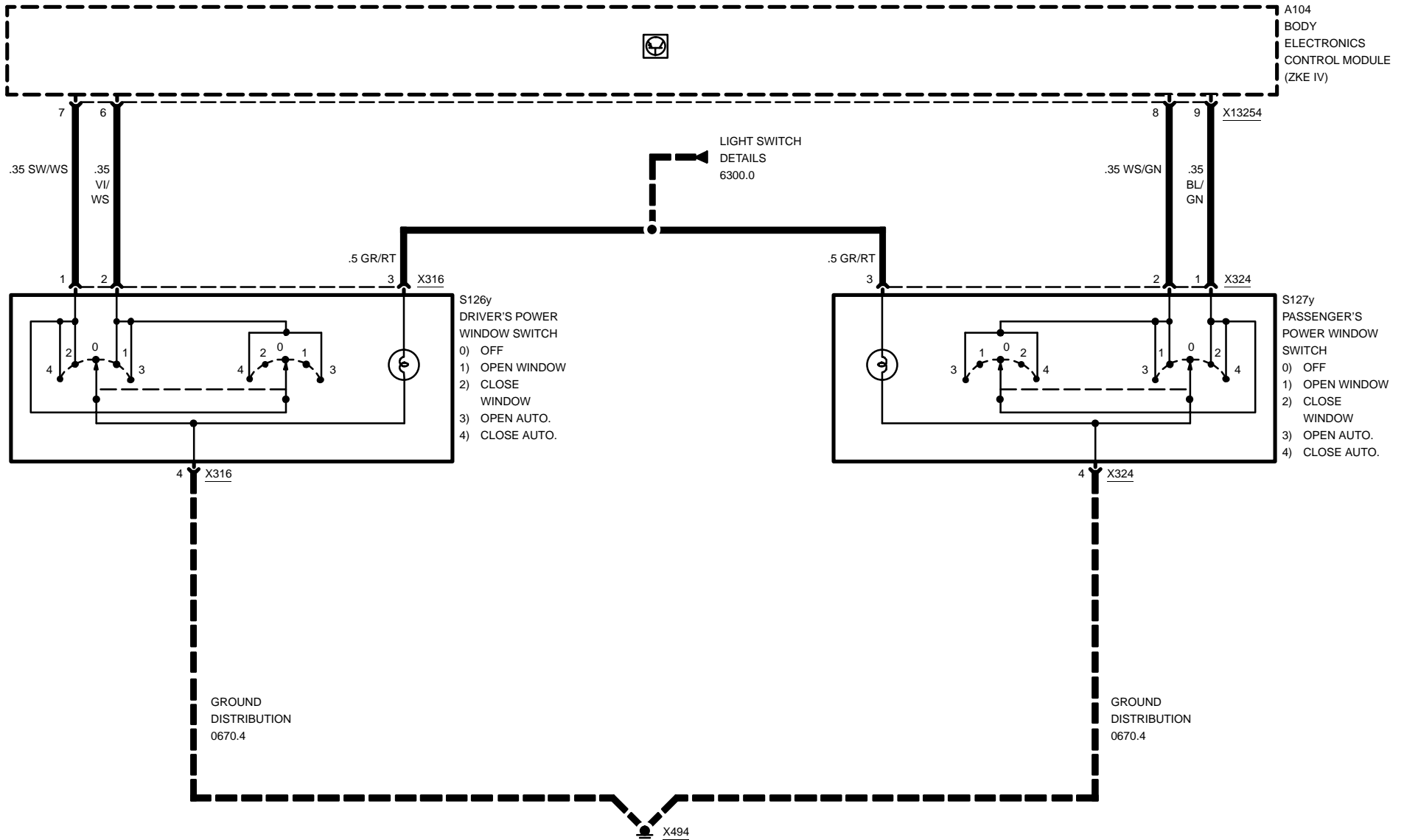



ZKE POWER WINDOWS (FH)

OUTPUT DETAILS

Z3

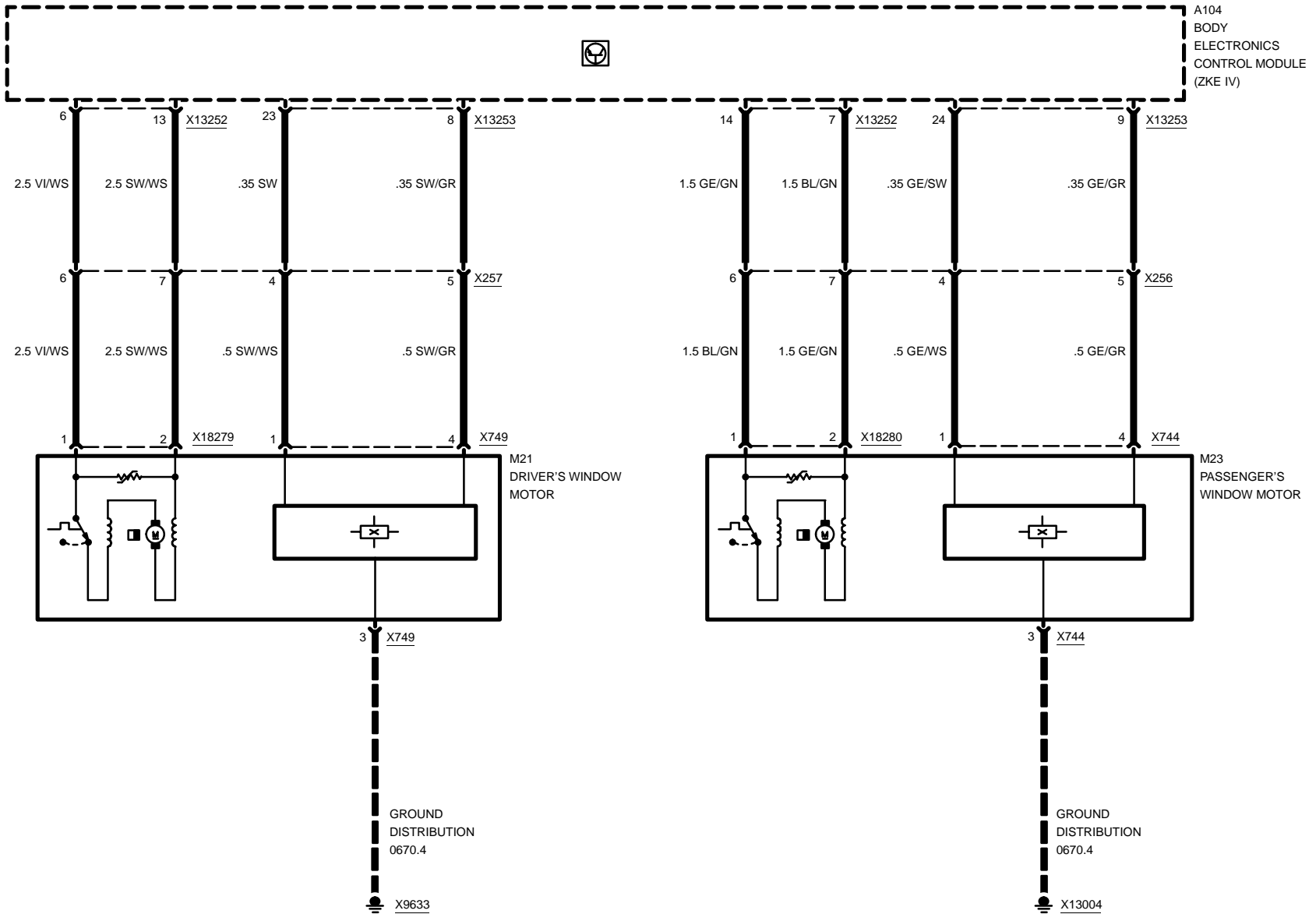

04/99

5133.0-02

1998



5200.0 POWER SEATS

DRIVER'S SEAT

04/99

5200.0-00

1998

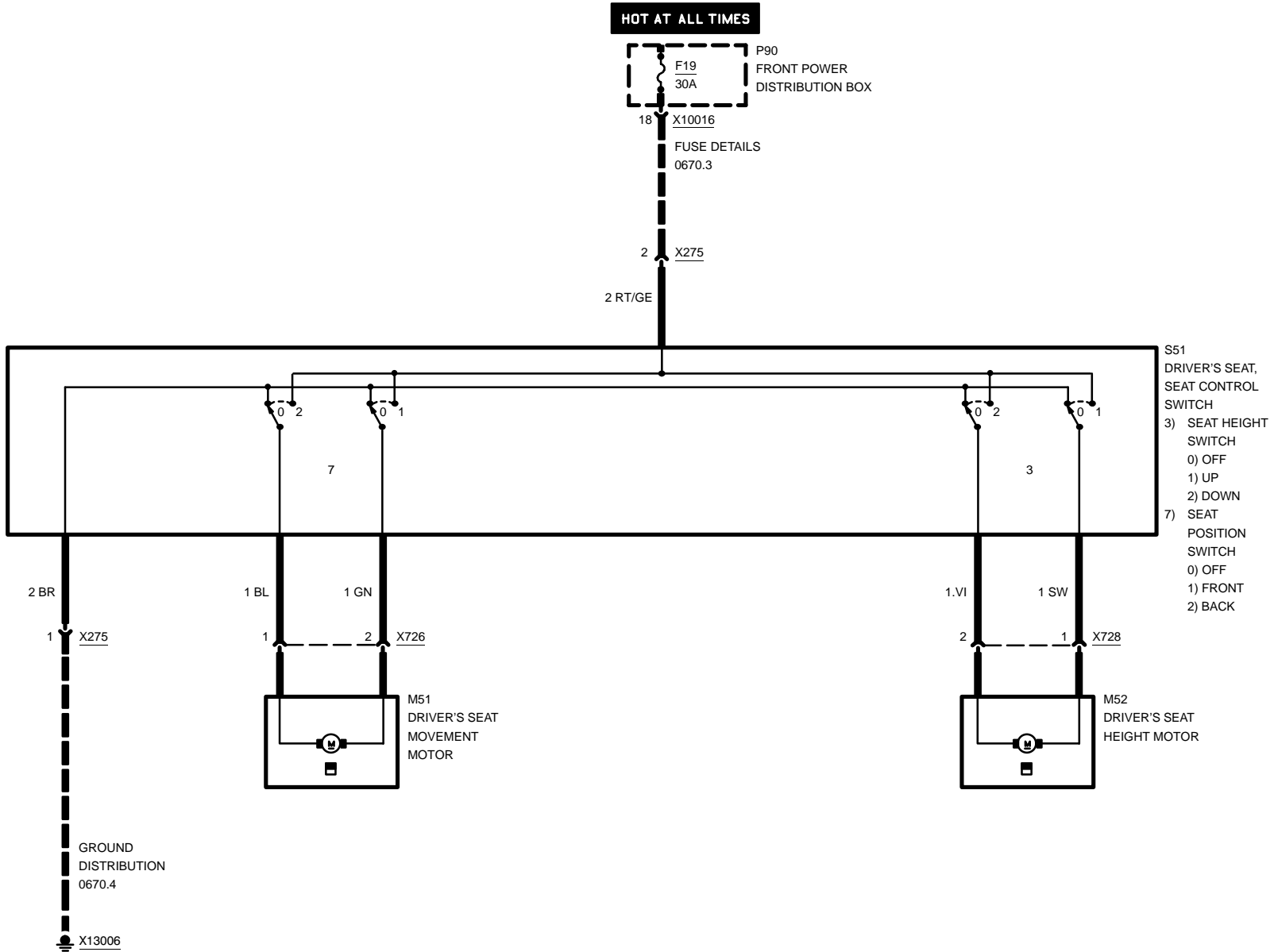



POWER SEATS

PASSENGER'S SEAT

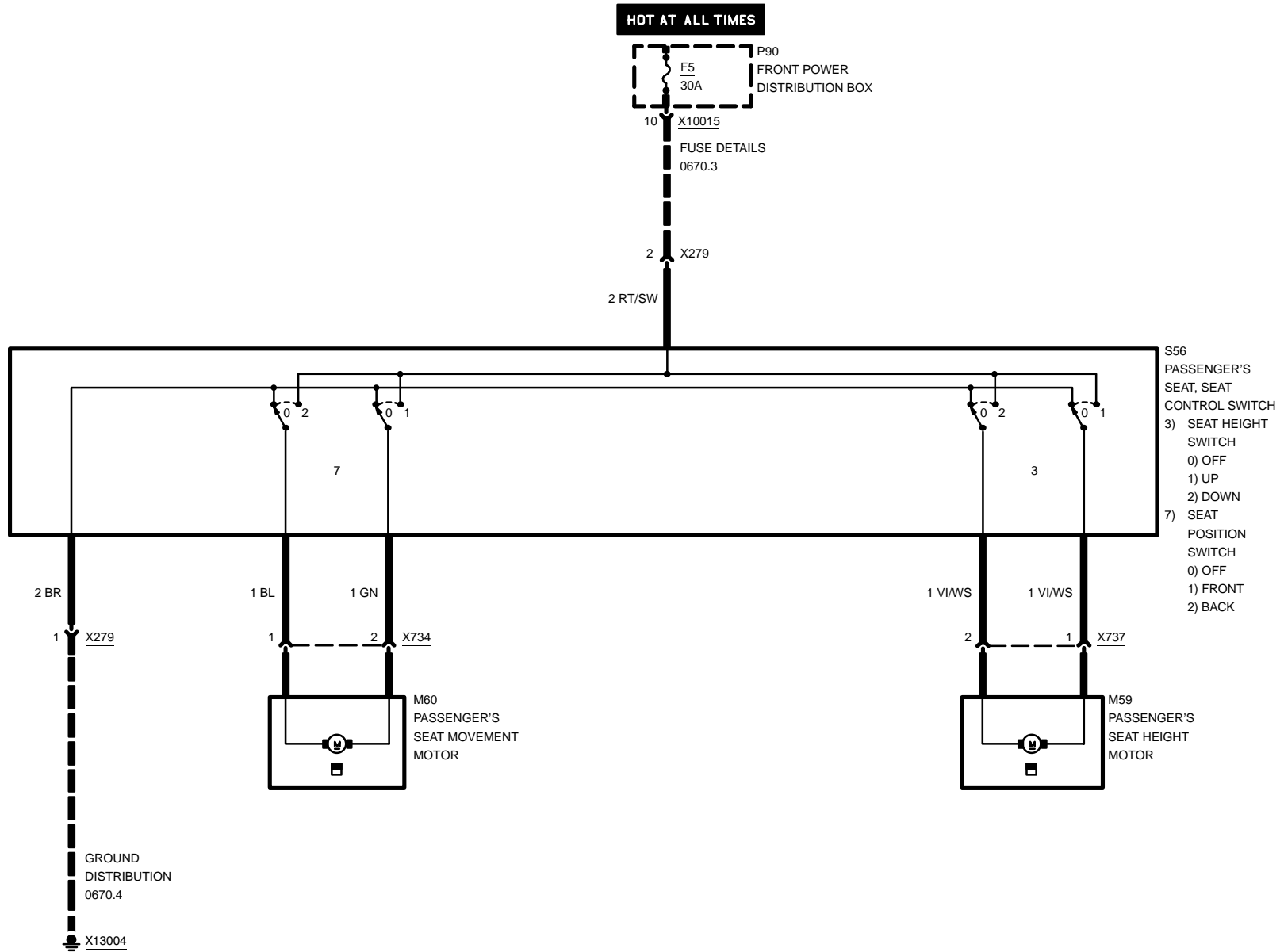



POWER SEATS PASSENGER'S SEAT

SPORT SEATS

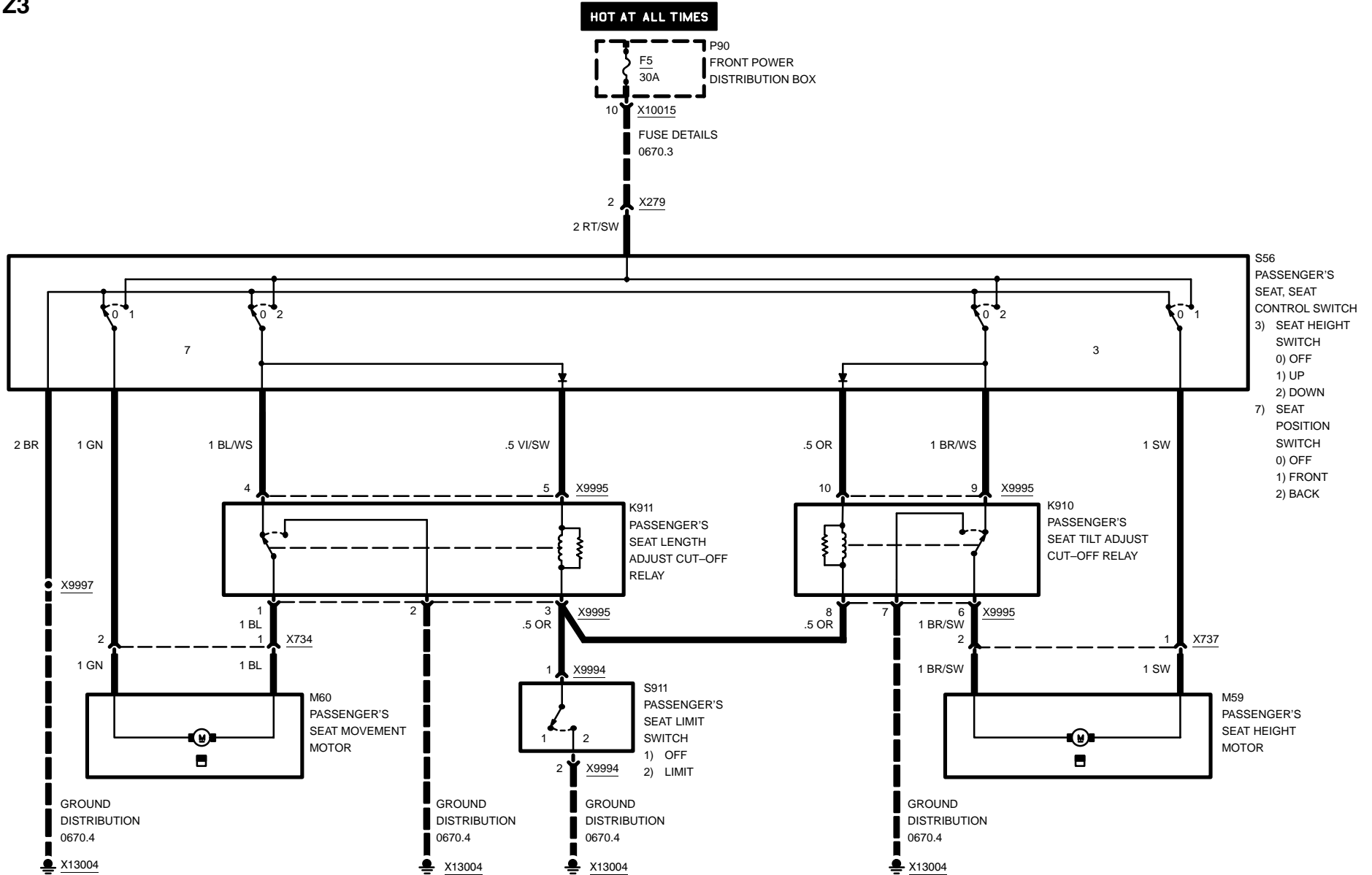



5203.0 HEATED SEATS

EARLY PRODUCTION

Z3

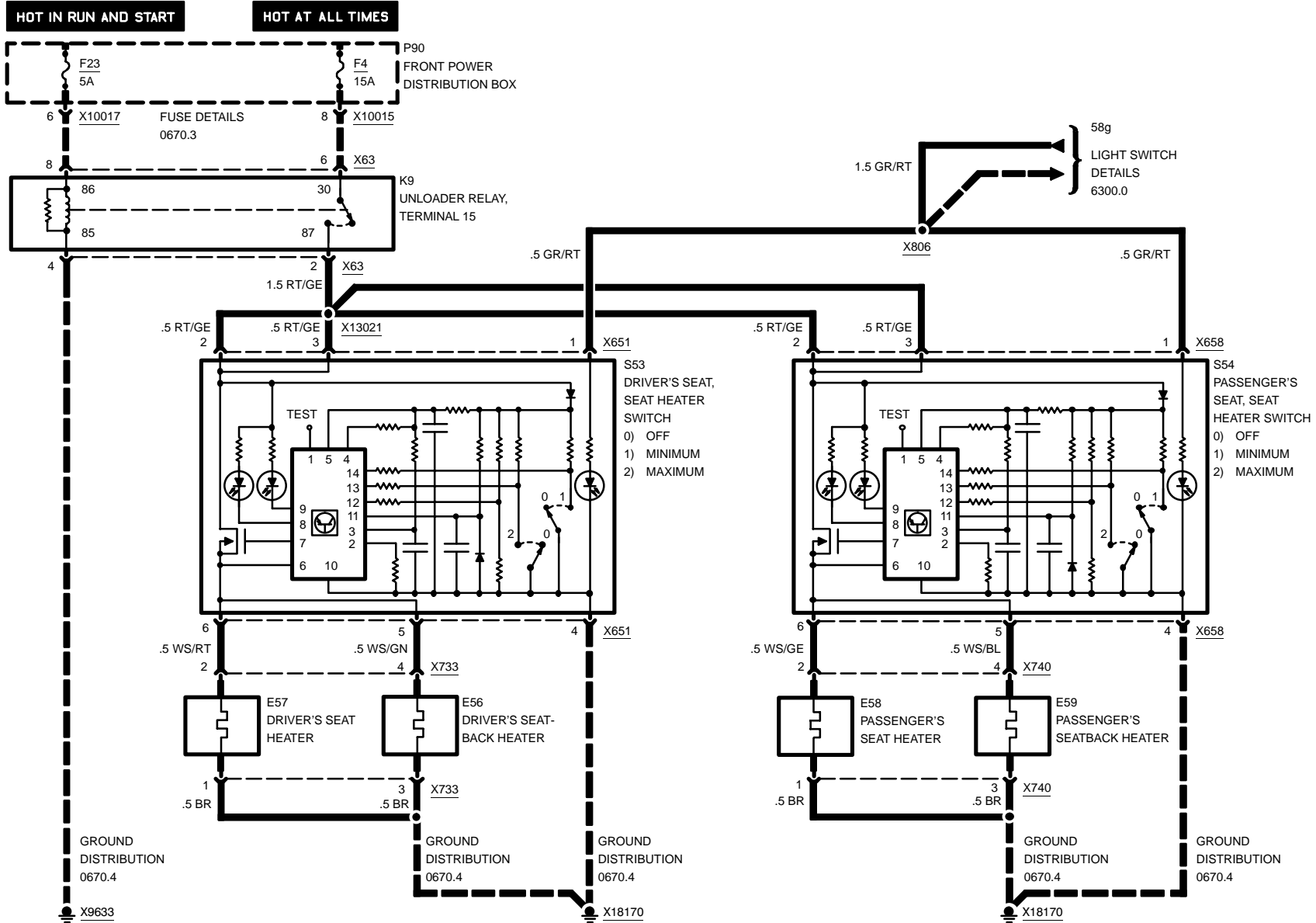

04/99

5203.0-00

1998



Z3

HEATED SEATS

LATE PRODUCTION

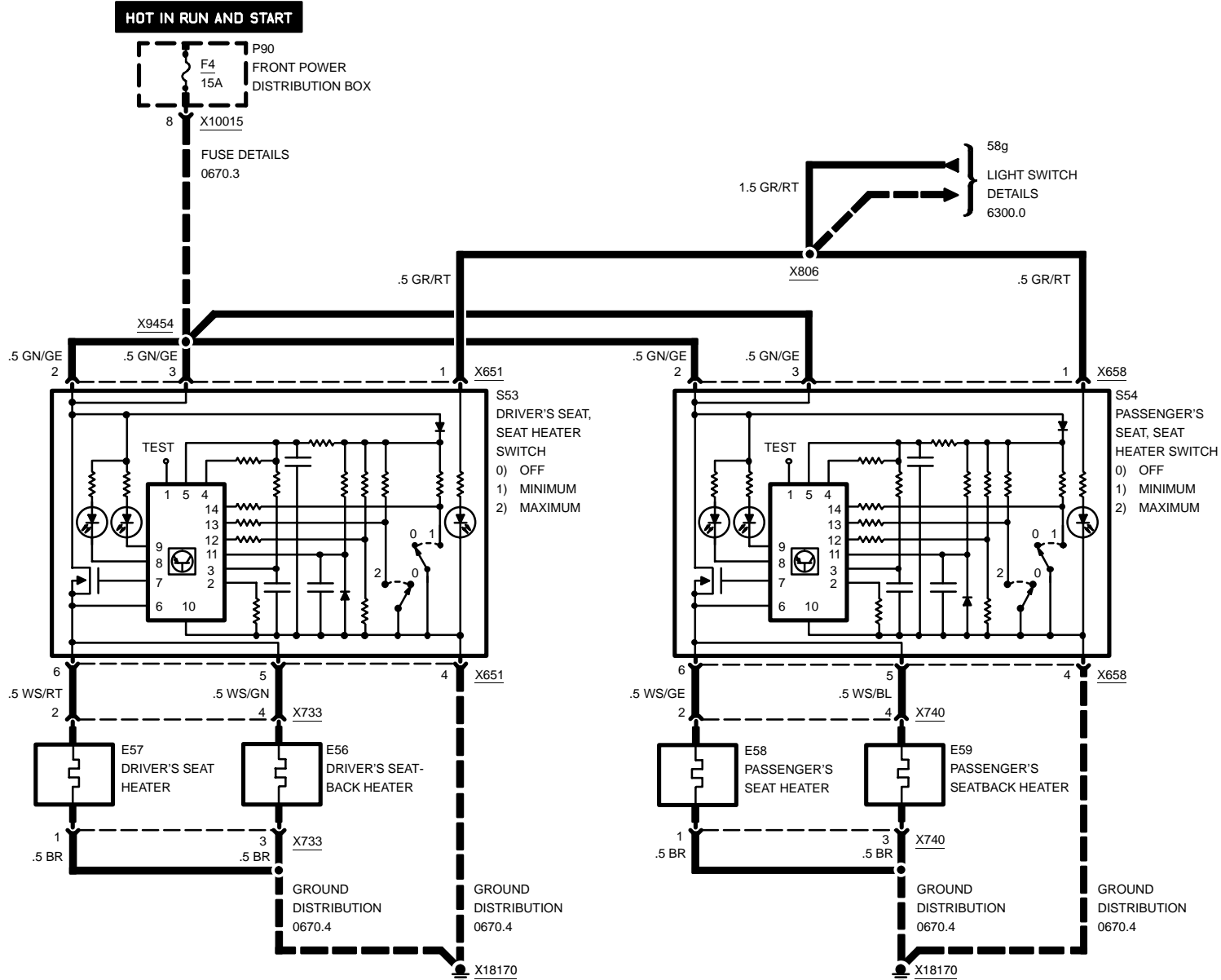

04/99

5203.0-01

1998

5430.2 ELECTRO-HYDRAULIC CONVERTIBLE TOP

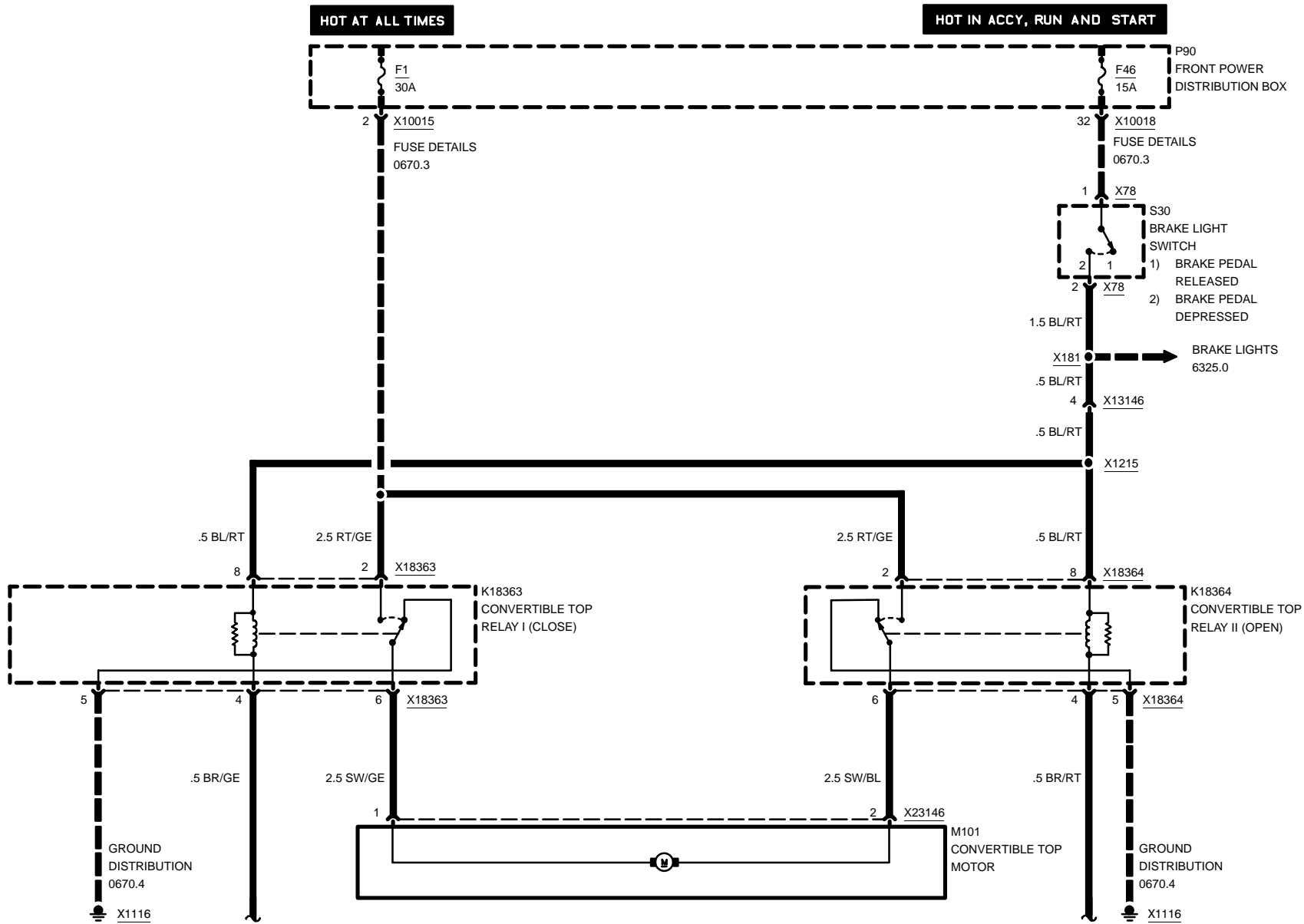

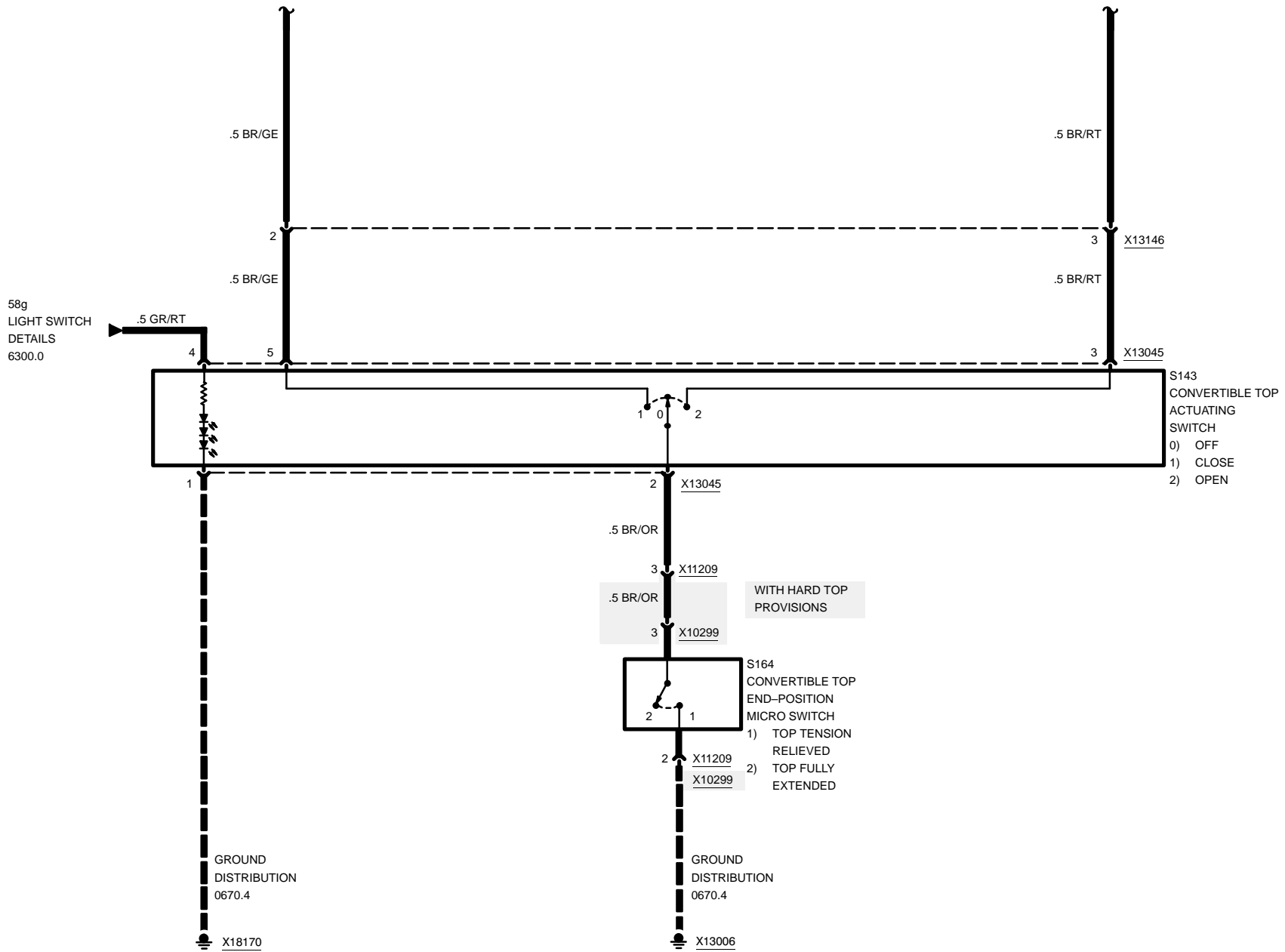

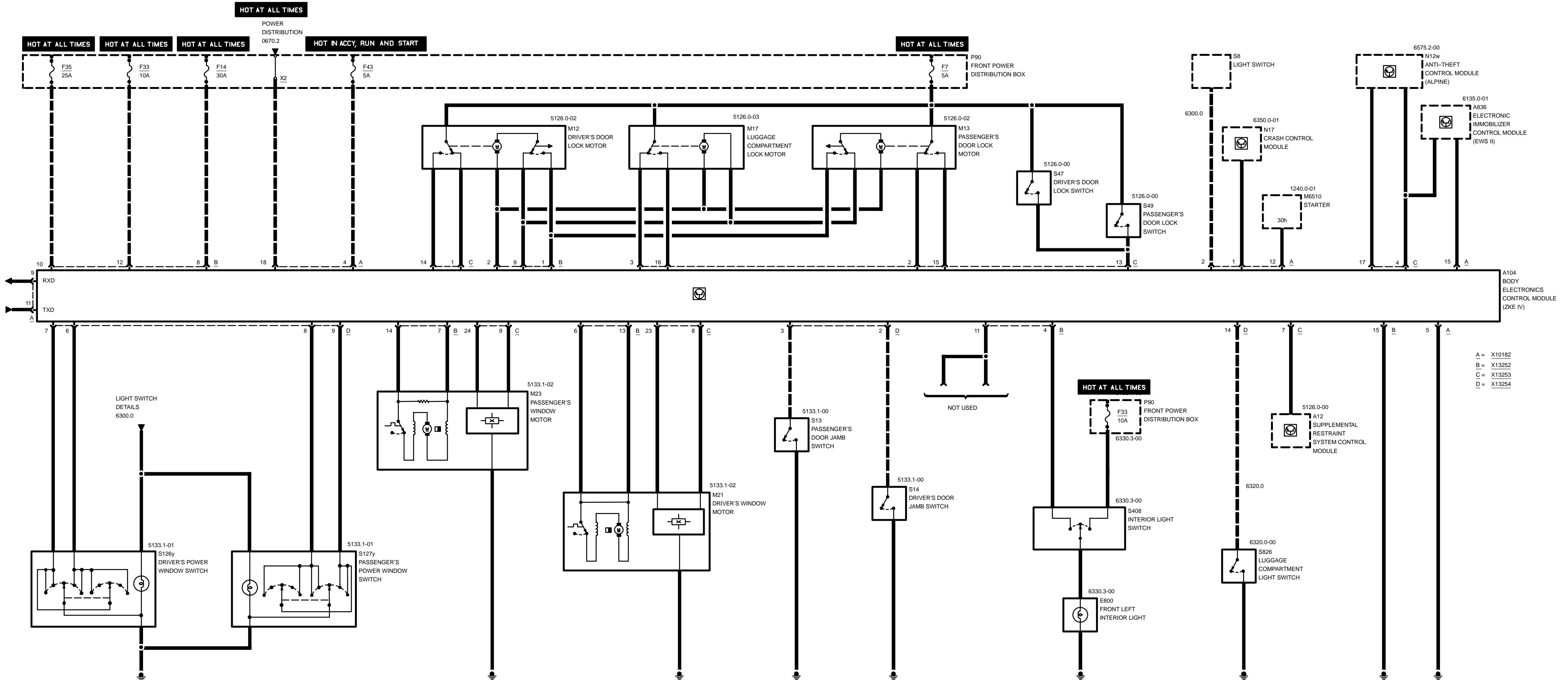



Z3

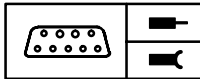

Pin Assignments

A = X10182	18 Pins, black
B = X13252	15 Pins, black
C = X13253	26 Pins, yellow
D = X13254	26 Pins, green

X10182

Pin	Type	Description/Function	Connection
1	E	Crash signal	Crash control module
2	E	Light signal	Light switch
3		Not used	
4	E	Power supply	Front power distribution box, fuse 43
5	M	Ground	Ground point
6		Not used	
7		Not used	
8		Not used	
9	A	Diagnosis RxD signal	Data link connector
10		Not used	
11	E/A	Diagnosis TxD signal	Data link connector
12	E	Start signal	Starter
13		Not used	
14		Not used	
15	A	Drive-away protection	Electronic immobilizer control module (EWS II)
16		Not used	
17		Not used	
18	E	Power supply	Front power distribution box

E = Input, A = Output, M = Ground

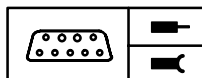

Z3

**Pin Assignments****X13252**

Pin	Type	Description/Function	Connection
1	A	Central arrest signal	Lock motors
2	A	Unlock signal	Lock motors
3		Not used	
4	A	Automatic interior light signal	Side light switch
5		Not used	
6	A	Voltage supply	Power window motor, driver's door
7	A	Voltage supply	Power window motor, passenger's door
8	E	Power supply	Front power distribution box, fuse 14
9	A	Lock signal	Lock motors
10	E	Power supply	Front power distribution box, fuse 35
11	A	Consumer cut-off signal	Not used
12	E	Power supply	Front power distribution box, fuse 33
13	E	Motor signal	Power window motor, driver's door
14	E	Motor signal	Power window motor, passenger's door
15	M	Ground	Ground point

X13253

Pin	Type	Description/Function	Connection
1	E	Unlock signal	Door lock motor, driver's door
2	E	Unlock signal	Door lock motor, passenger's door
3	E	Unlock signal	Luggage compartment lock motor
4	E	Data signal	Anti-theft system control module (Alpine)
5		Not used	
6		Not used	
7	E	Crash signal	Supplemental restraint system control module
8	E	Revolution signal	Power window motor, driver's door
9	E	Revolution signal	Power window motor, passenger's door
10		Not used	

E = Input, A = Output, M = Ground

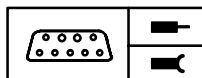

Z3

**Pin Assignments**

Pin	Type	Description/Function	Connection
11		Not used	
12		Not used	
13	E	Central arrest signal	Door lock switches
14	E	Lock signal, driver's door	Door lock motor, driver's door
15	E	Lock signal, passenger's door	Door lock motor, passenger's door
16	E	Lock signal, luggage compartment lid	Luggage compartment lock motor
17	E	Data signal	Anti-theft system control module (Alpine)
18		Not used	
19		Not used	
20		Not used	
21		Not used	
22		Not used	
23	A	Plus supply (revolution)	Power window's motor, driver's side
24	A	Voltage supply (revolution)	Power window's motor, passenger's side
25		Not used	
26		Not used	

X13254

Pin	Type	Description/Function	Connection
1		Not used	
2	E	Door signal	Door jamb switch, driver's door
3	E	Door signal	Door jamb switch, passenger's door
4		Not used	
5		Not used	
6	E	OPEN signal	Power window switch, driver's door
7	E	CLOSE signal	Power window switch, driver's door
8	E	OPEN signal	Power window switch, passenger's door
9	E	CLOSE signal	Power window switch, passenger's door
10		Not used	
11		Not used	
12		Not used	

E = Input, A = Output, M = Ground



Z3

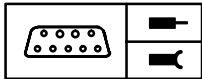

Pin Assignments

Pin	Type	Description/Function	Connection
13		Not used	
14	E	Luggage compartment signal	Luggage compartment light switch
15		Not used	
16		Not used	
17		Not used	
18		Not used	
19		Not used	
20		Not used	
21		Not used	
22		Not used	
23		Not used	
24		Not used	
25		Not used	
26		Not used	

E = Input, A = Output, M = Ground

CENTRAL BODY ELECTRONICS (ZKE IV)

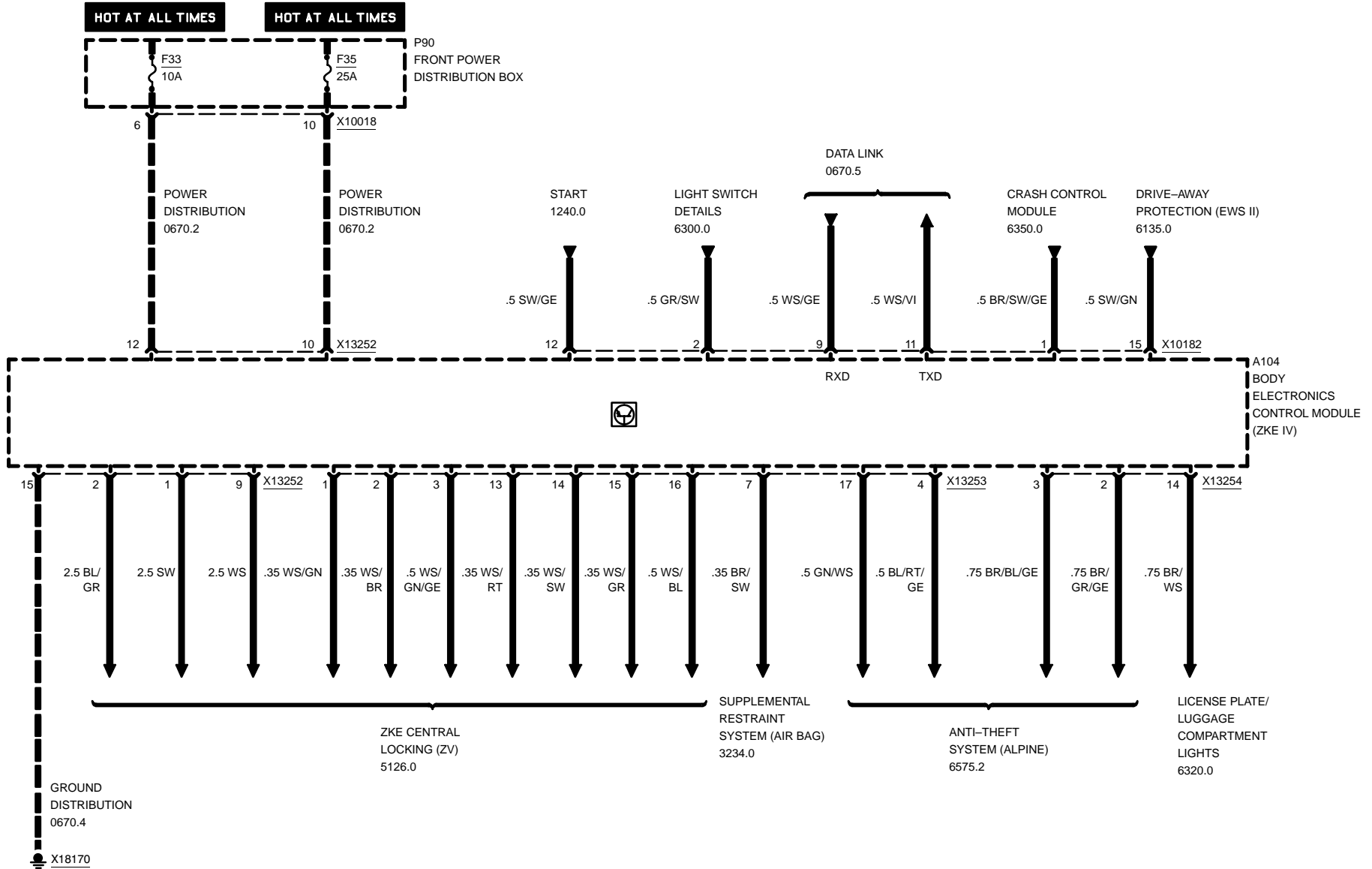



Z3

CENTRAL BODY ELECTRONICS (ZKE IV)

HOT AT ALL TIMES

POWER
DISTRIBUTION
0670.2

HOT IN ACCY, RUN AND START

HOT AT ALL TIMES

P90
FRONT POWER
DISTRIBUTION BOX

NOT USED

A104
BODY
ELECTRONICS
CONTROL MODULE
(ZKE IV)

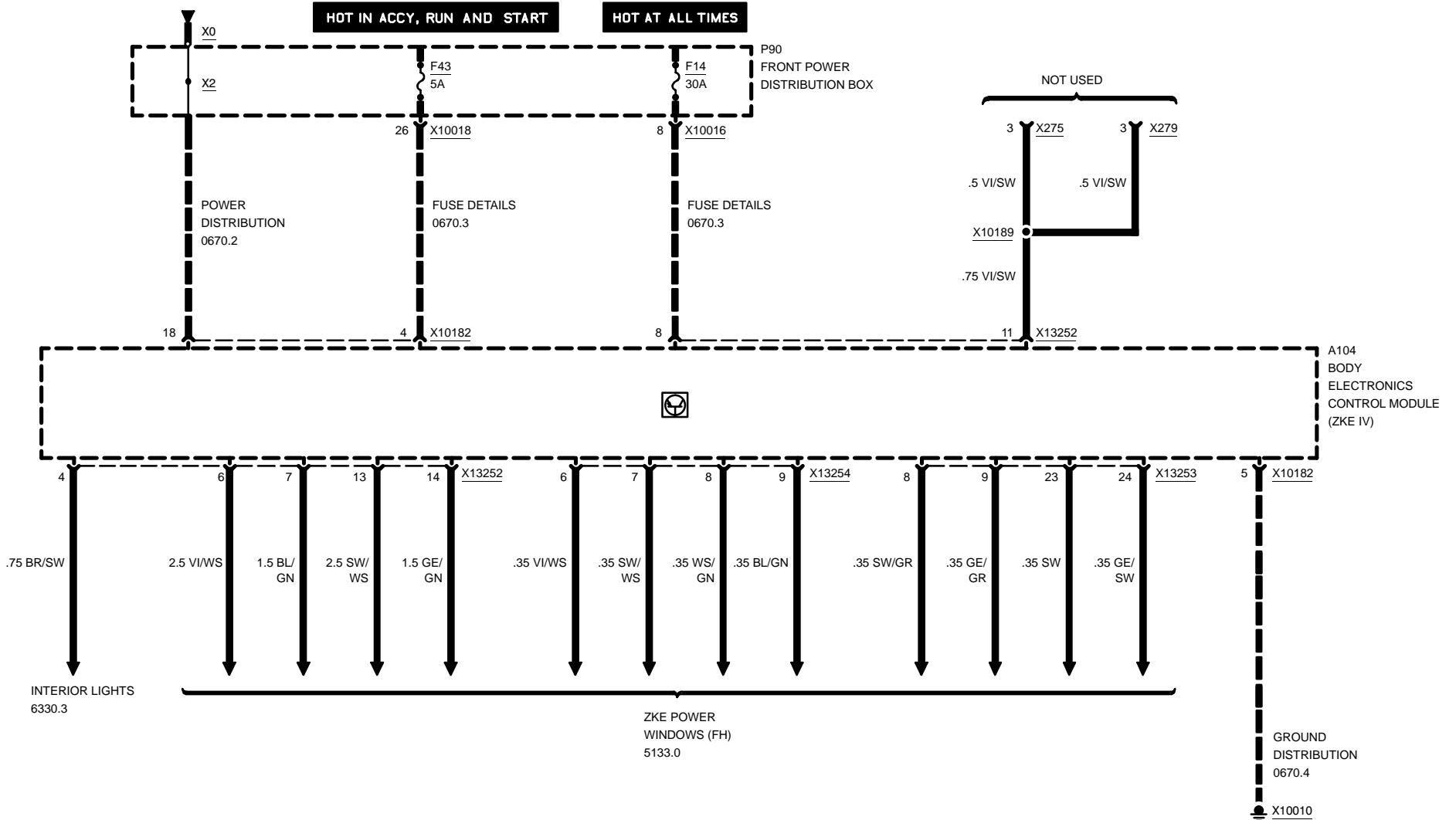

04/99

6100.0-01

1998

6133.0 HORN

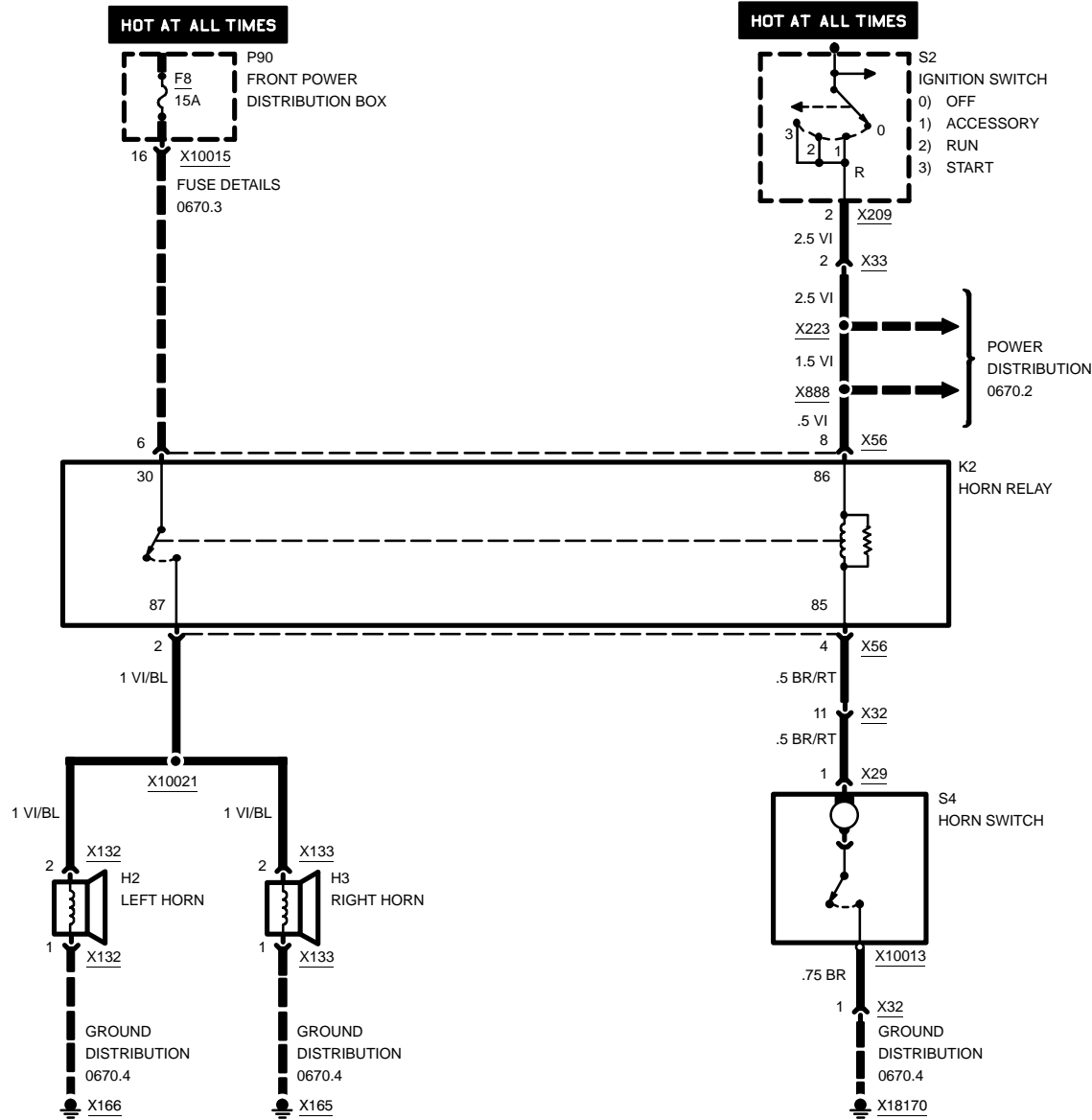



6135.0 DRIVE-AWAY PROTECTION (EWS II)

Z3

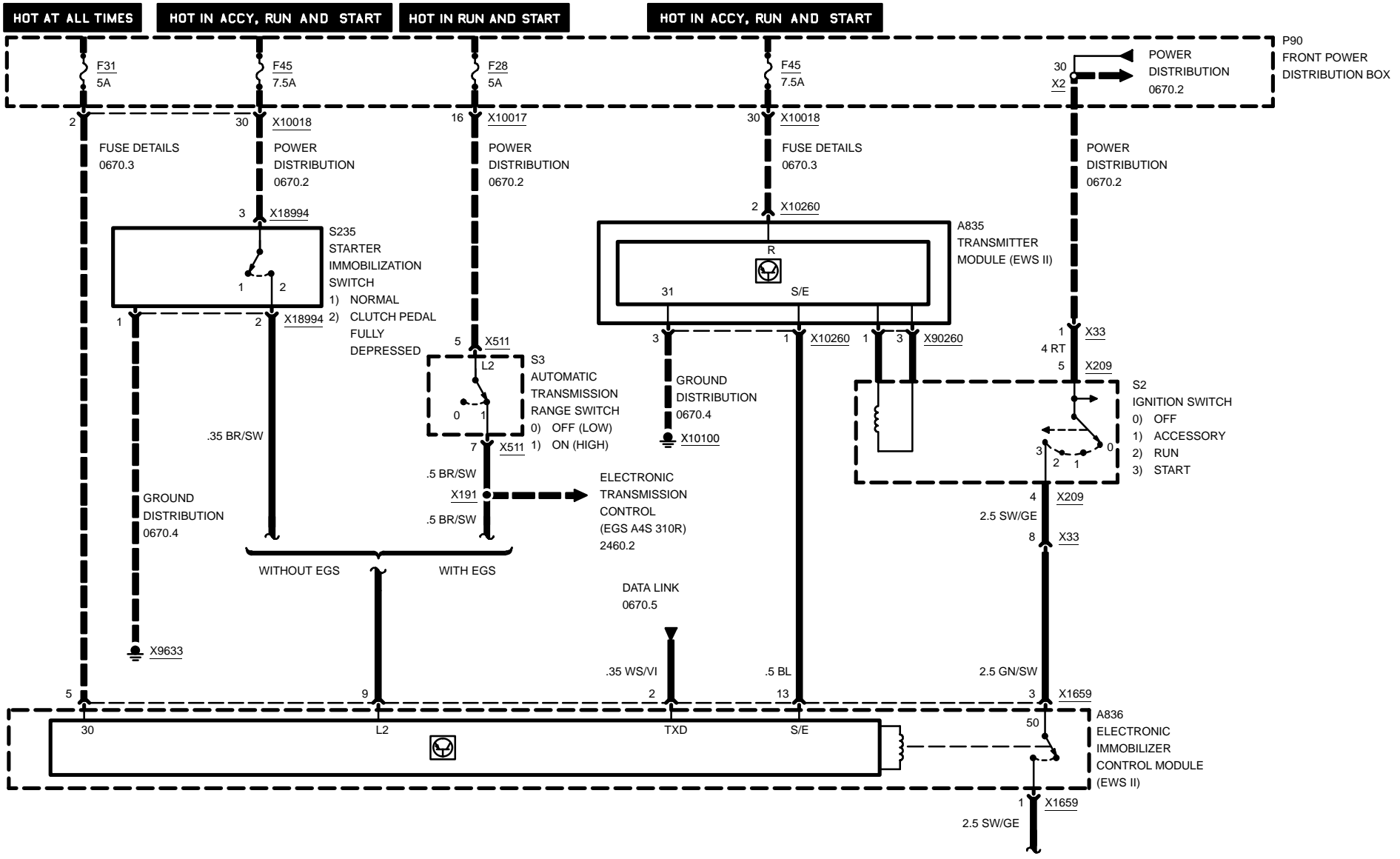

04/99

6135.0-00

1998

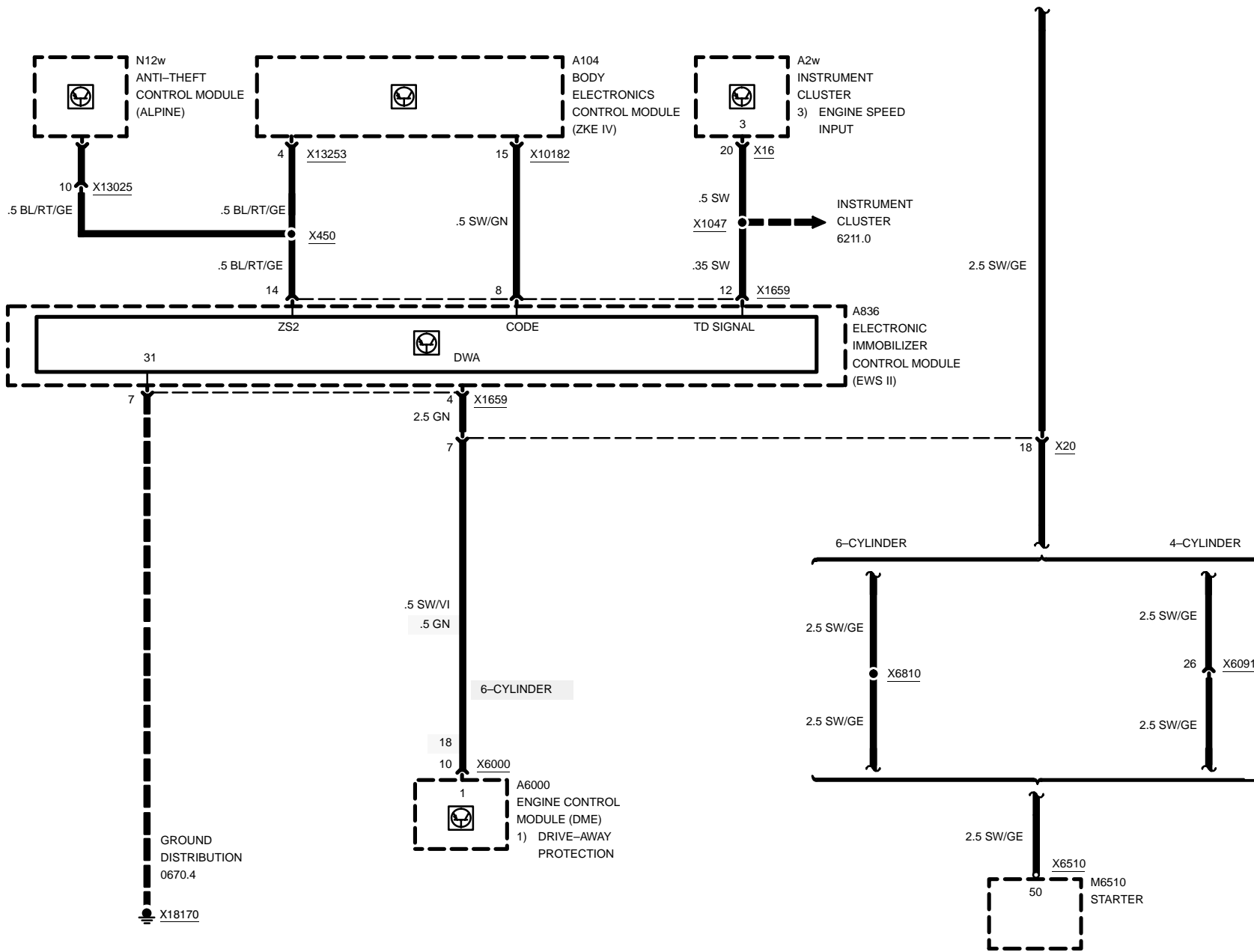

6160.1 WIPER/WASHER MODULE (WWM)

HIGH

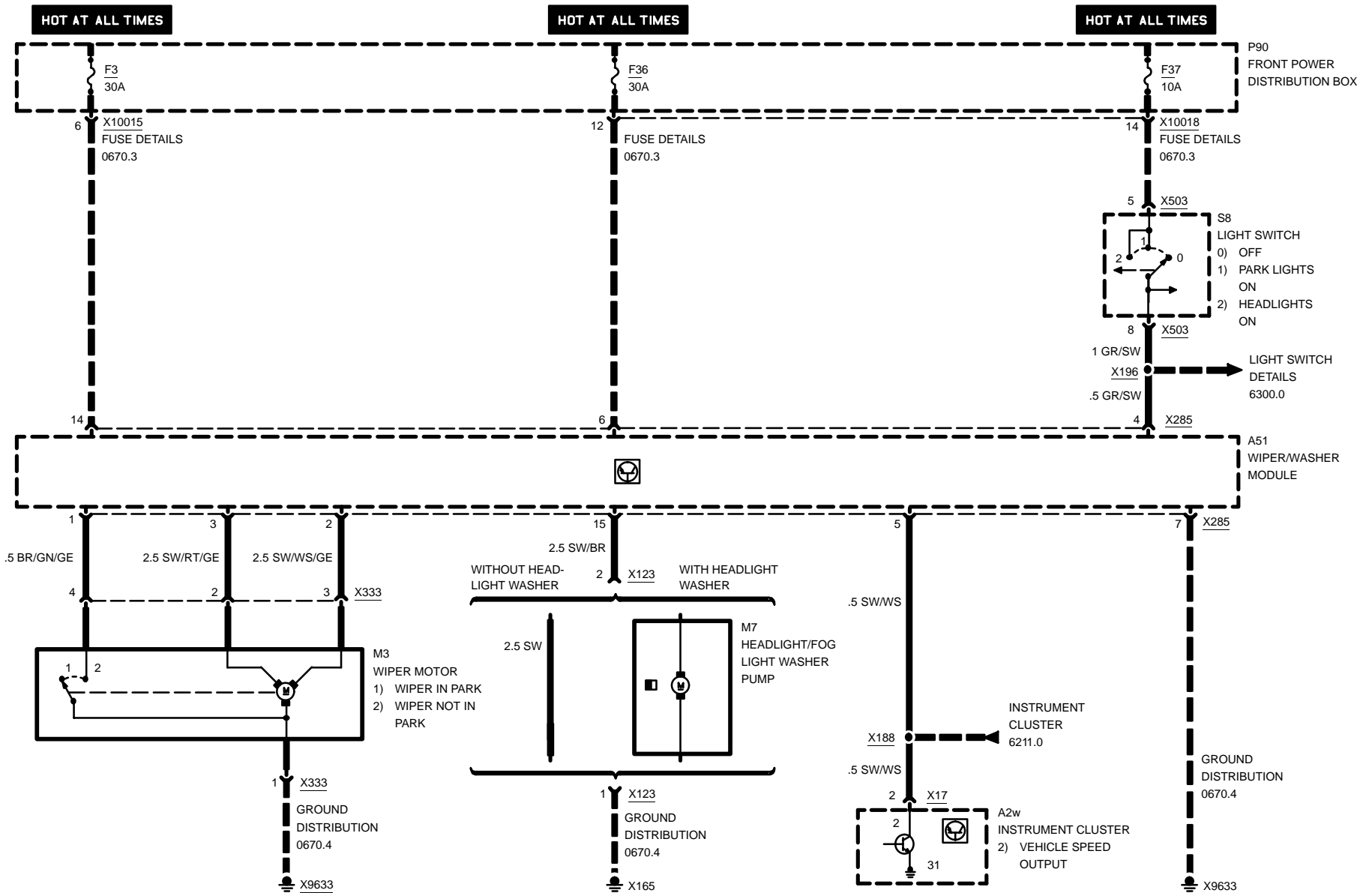

WIPER/WASHER MODULE (WWM)

HIGH

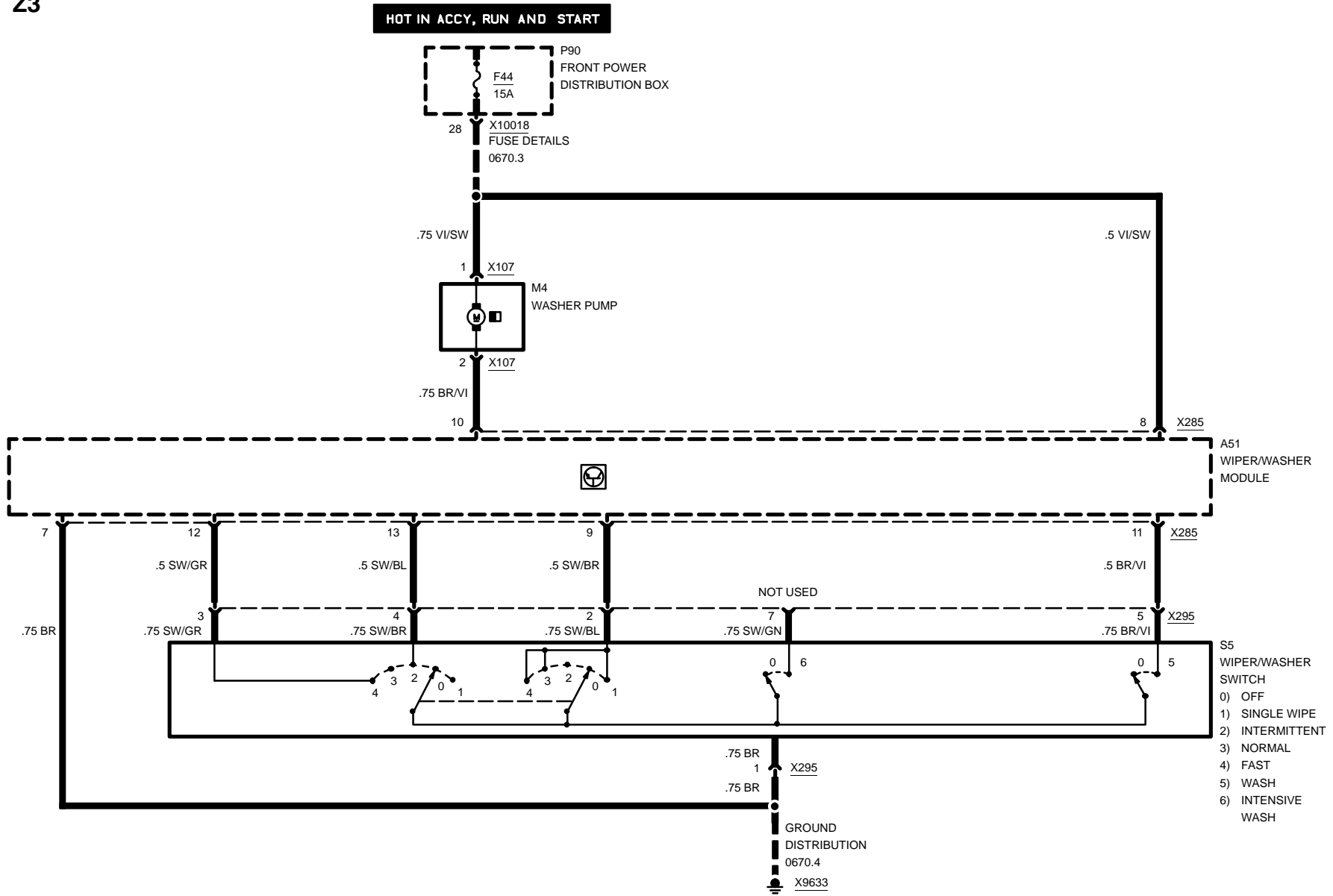

WIPER/WASHER MODULE (WWM)

LOW

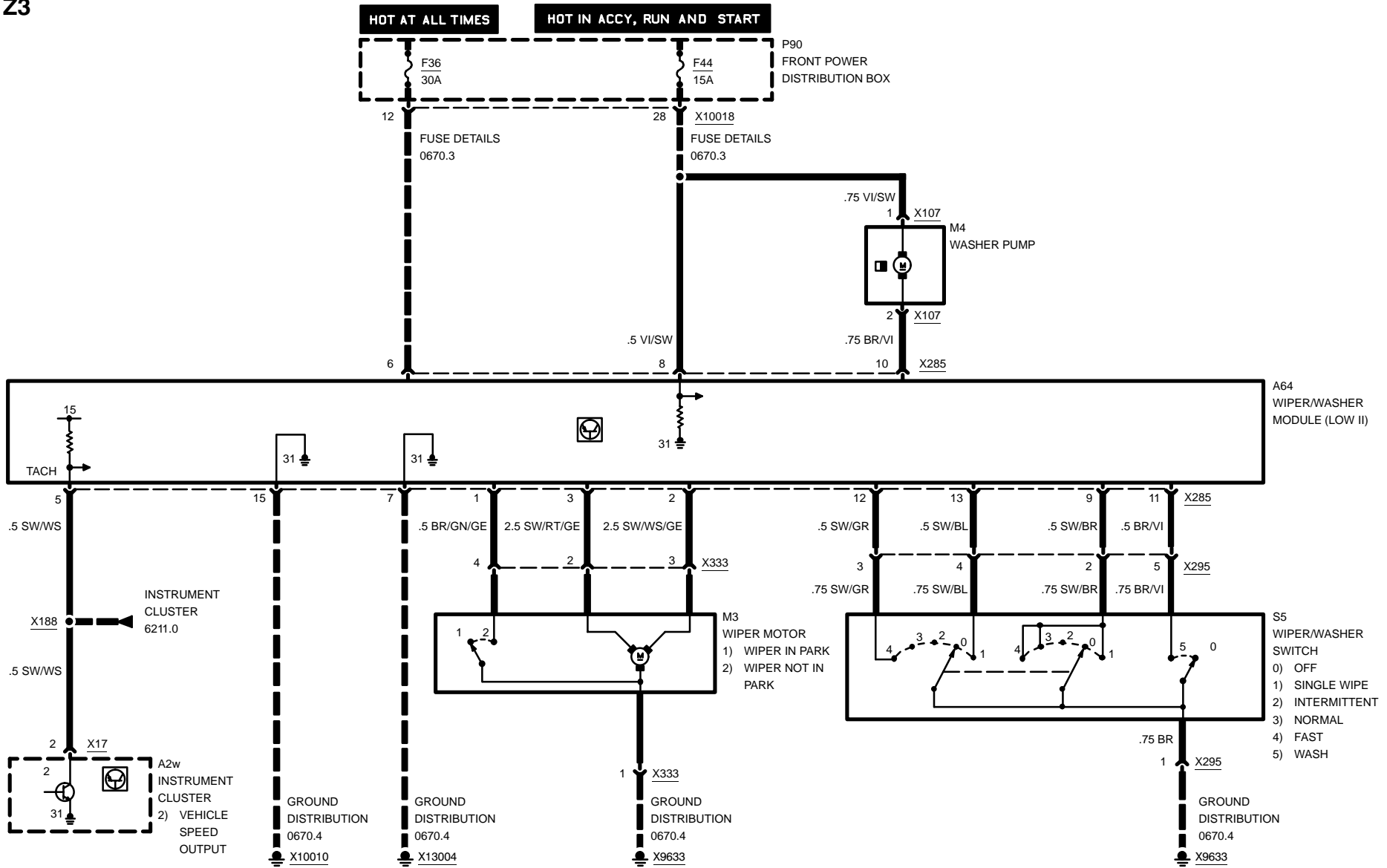

6167.1 HEADLIGHT WASHER (SRA)

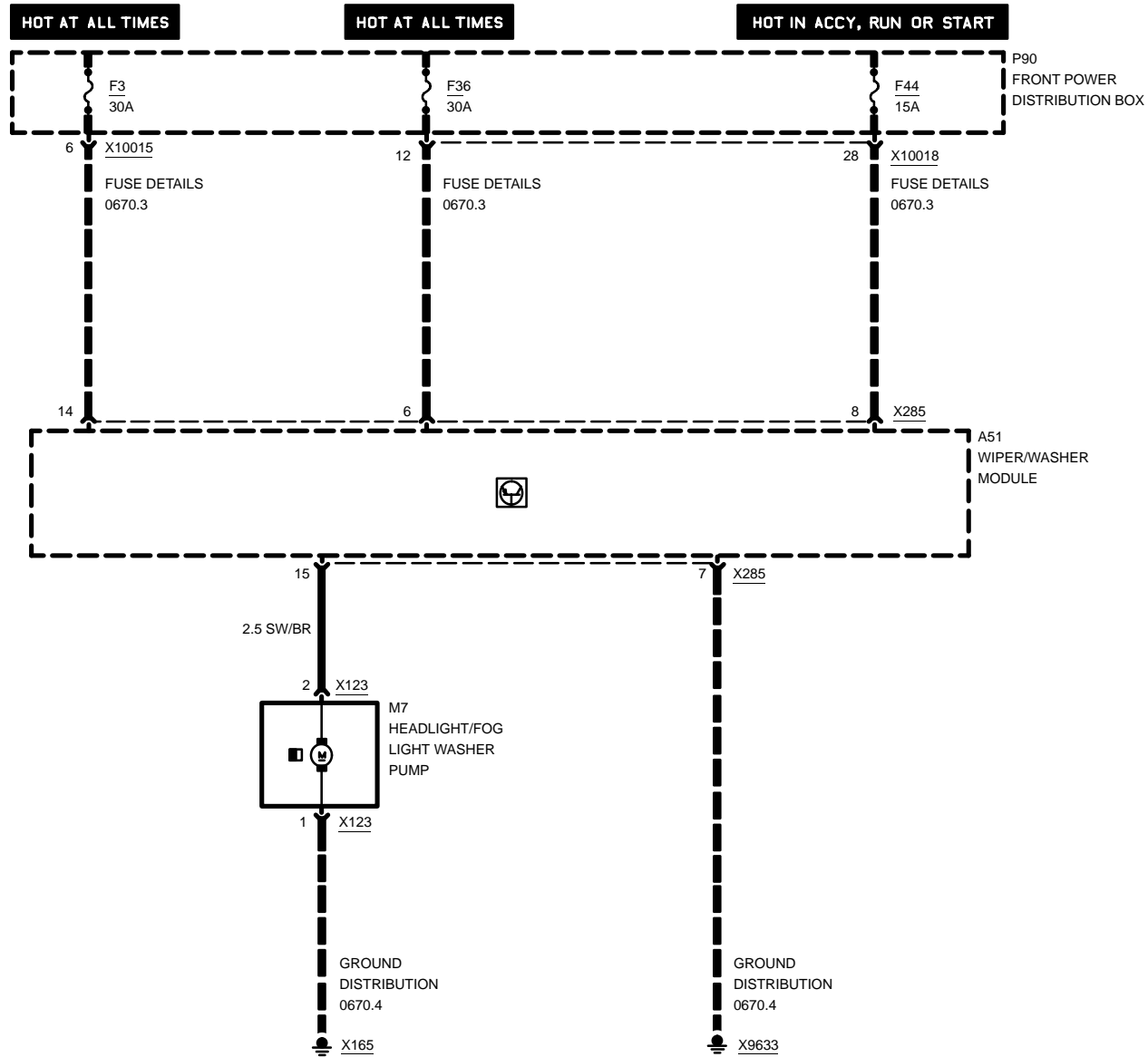



Z3

6169.0 WINDSHIELD WASHER JET HEATERS

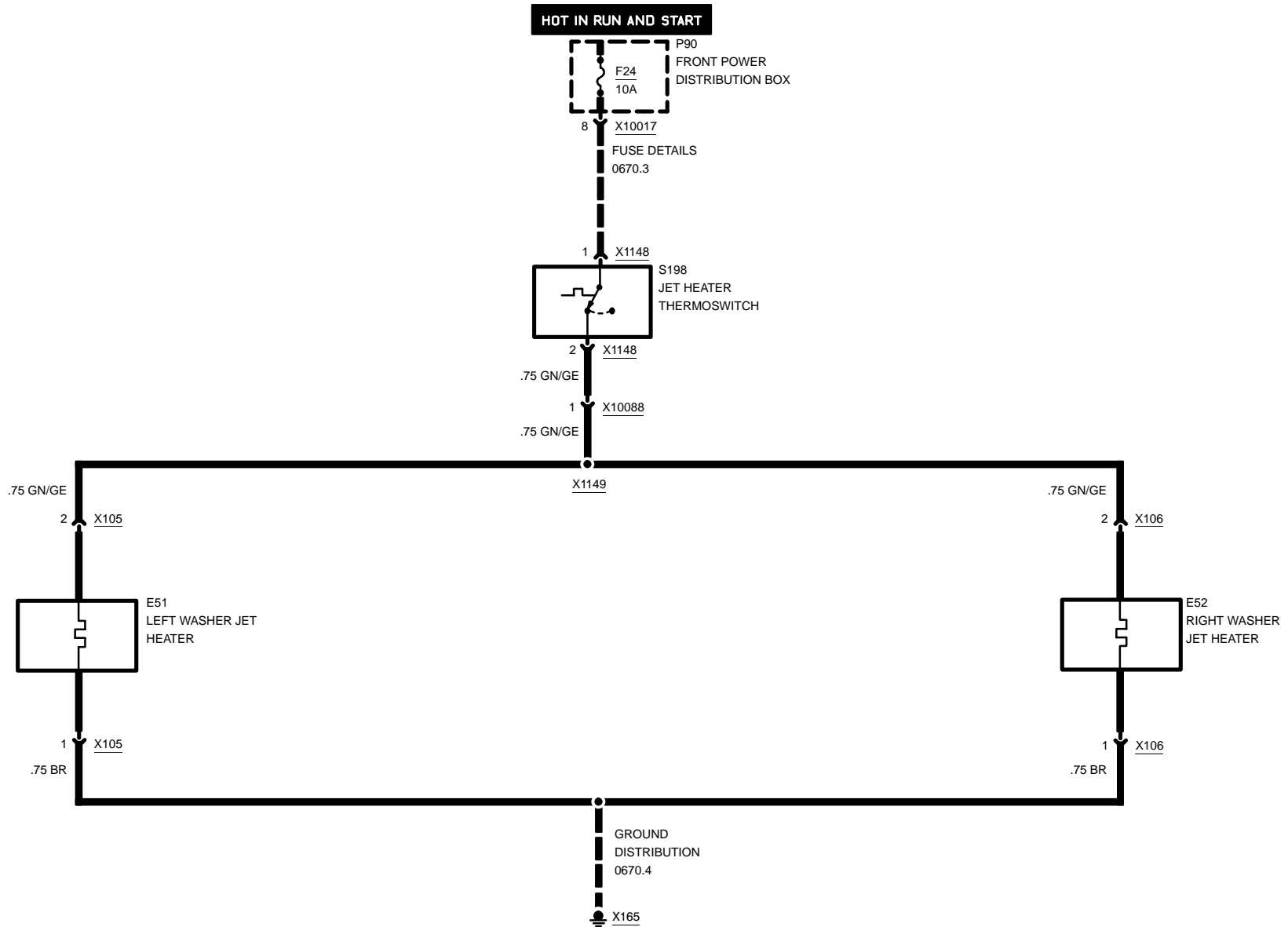

04/99

6169.0-00

1998

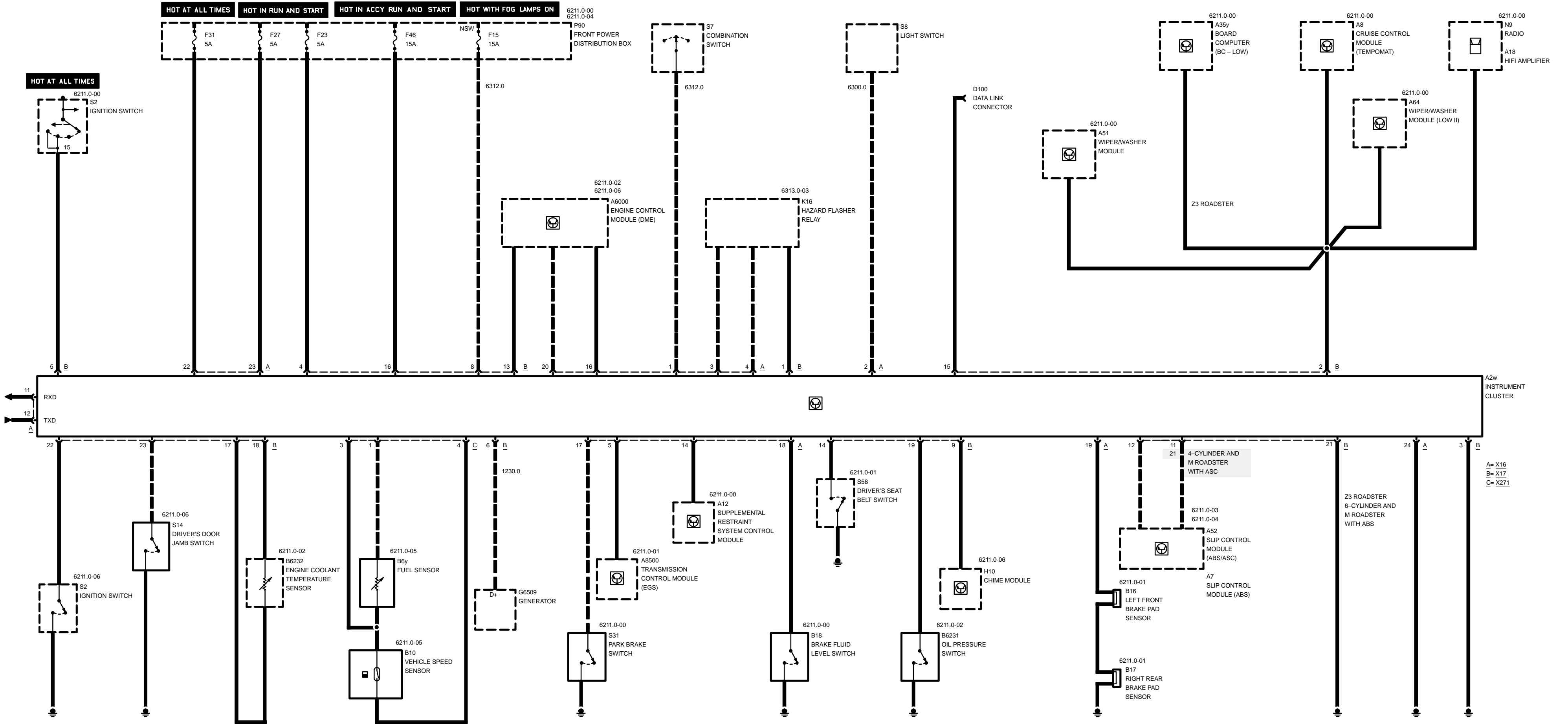



Z3

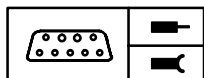

Pin Assignments

X16

Pin	Type	Description/Function	Connection
1	E	High beam indicator control	Combination switch
2	E	Terminal 58g, instrument illumination power	Light switch (dimmer)
3	E	Right turn signal indicator control	Hazard flasher relay
4	E	Left turn signal indicator control	Hazard flasher relay
5	E	Warning lamp for EGS fault (information signal transmission oil temperature)	Transmission control module (EGS)
6		Not used	
7		Not used	
8		Not used	
9		Not used	
10		Not used	
11	A	Diagnosis RxD signal	Data link connector (M Roadster)
12	E/A	Diagnosis TxD signal	Data link connector
13		Not used	
14	E	Airbag warning lamp (SRS) control	Supplemental restraint system control module
15		Not used	
16	E	"Check engine" indicator control	Engine control module (DME)
17	E	Park brake warning lamp control	Park brake switch
18	E	Brake fluid warning lamp control	Brake fluid level switch
19	E	Brake pad wear warning lamp control	Brake pad sensors
20	E	Crankshaft RPM speed signal TD	Engine control module (DME)
21		Not used	
22	E	Voltage supply, terminal 30	Front power distribution box, fuse 31
23	E	Voltage supply, terminal 15 for indicator and warning lamps	Front power distribution box, fuse 27
24	M	Ground supply, terminal 31 for instrument cluster electronics	Ground point
25		Not used	
26		Not used	

E = Input, A = Output, M = Ground



Z3

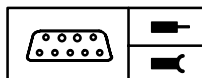

Pin Assignments

X17

Pin	Type	Description/Function	Connection
1	E	Trailer turn signal indicator control	Hazard flasher relay
2	A	Vehicle speed signal	Various control modules
3	M	Ground supply, terminal 31 for indicator and warning lamps	Ground point
4	E	Voltage supply, terminal 15 for instrument cluster electronics	Front power distribution box, fuse 23
5	E	Voltage supply, terminal 15 for battery charge indicator	Ignition switch, terminal 15
6	E	Ground supply, terminal 61 for battery charge indicator	Generator
7		Not used	
8	E	Fog light indicator control	Front power distribution box, fuse 15
9	A	Sound tone signal	Chime module
10		not used	
11	E	Slip control system warning lamp (ABS) control	Slip control module (ABS/ASC) (Z3 Roadster 6-cylinder and M Roadster with ABS)
12	E	ASC signal	ASC control module
13	A	TI-measurement signal (fuel consumption)	Engine control module (DME)
14	E	Seat belt warning lamp control	Driver's seat belt switch
15	E	SIA reset/service interval indicator reset	Data link connector
16	E	Voltage supply, terminal R	Front power distribution box, fuse 46
17	A	Coolant temperature sensor (-)	Coolant temperature sensor
18	E	Coolant temperature sensor (+)	Coolant temperature sensor
19	E	Oil pressure warning lamp control	Oil pressure switch
20		Not used	
21	M	Ground (ASC)	Ground point (Z3 Roadster 6-cylinder and M Roadster with ABS)
21	E	ABS warning lamp (ABS)	Slip control module (ABS/ASC) (4-cylinder and M Roadster with ASC)
22	E	Ignition key warning/audible ignition key warning	Ignition switch
23	E	Driver's door open	Driver's door jamb switch

E = Input, A = Output, M = Ground



Z3

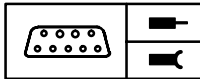

Pin Assignments

Pin	Type	Description/Function	Connection
24		Not used	
25		Not used	
26		Not used	

X271

Pin	Type	Description/Function	Connection
1	A	Fuel level sensor	Fuel tank sensors
2		Not used	
3	A	Ground supply for fuel tank sensor and vehicle speed sensor	Fuel tank sensor and vehicle speed sensor
4	E	Position signal TW	Vehicle speed sensor
5		Not used	
6		Not used	
7		Not used	
8		Not used	
9		Not used	
10		Not used	
11		Not used	
12		Not used	

E = Input, A = Output, M = Ground

INSTRUMENT CLUSTER INDICATORS

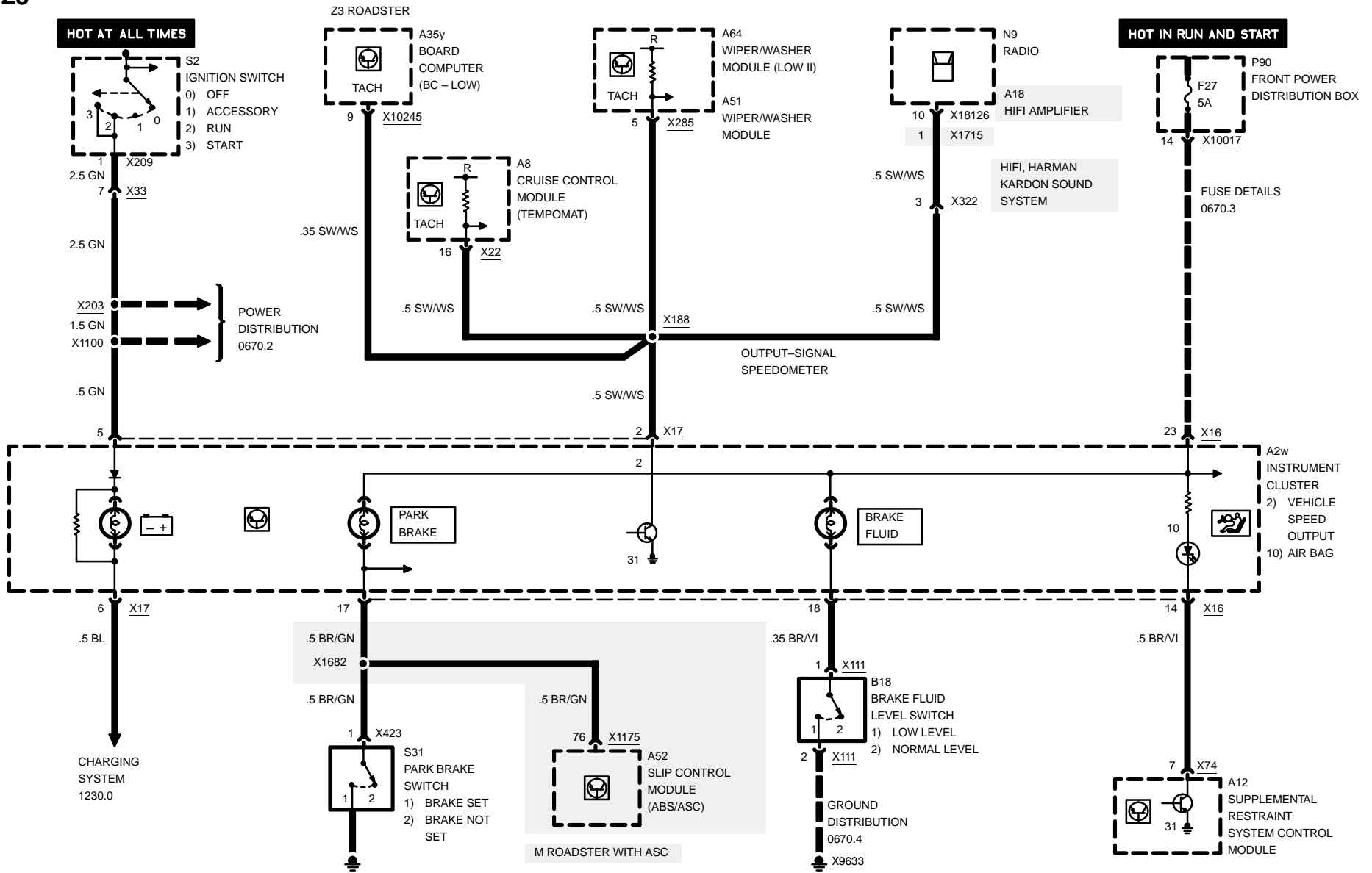



INSTRUMENT CLUSTER INDICATORS

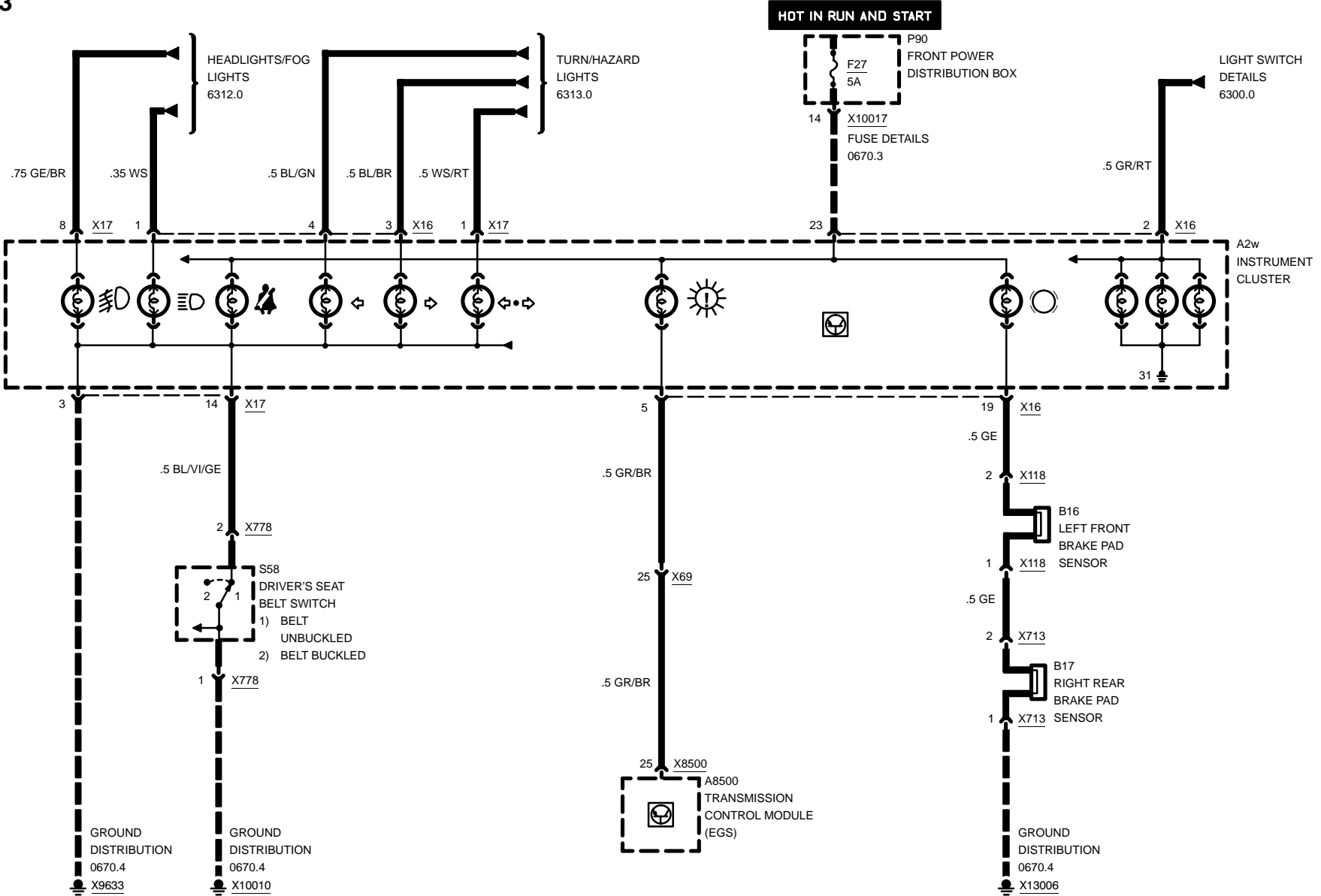



INSTRUMENT CLUSTER

INDICATORS

Z3

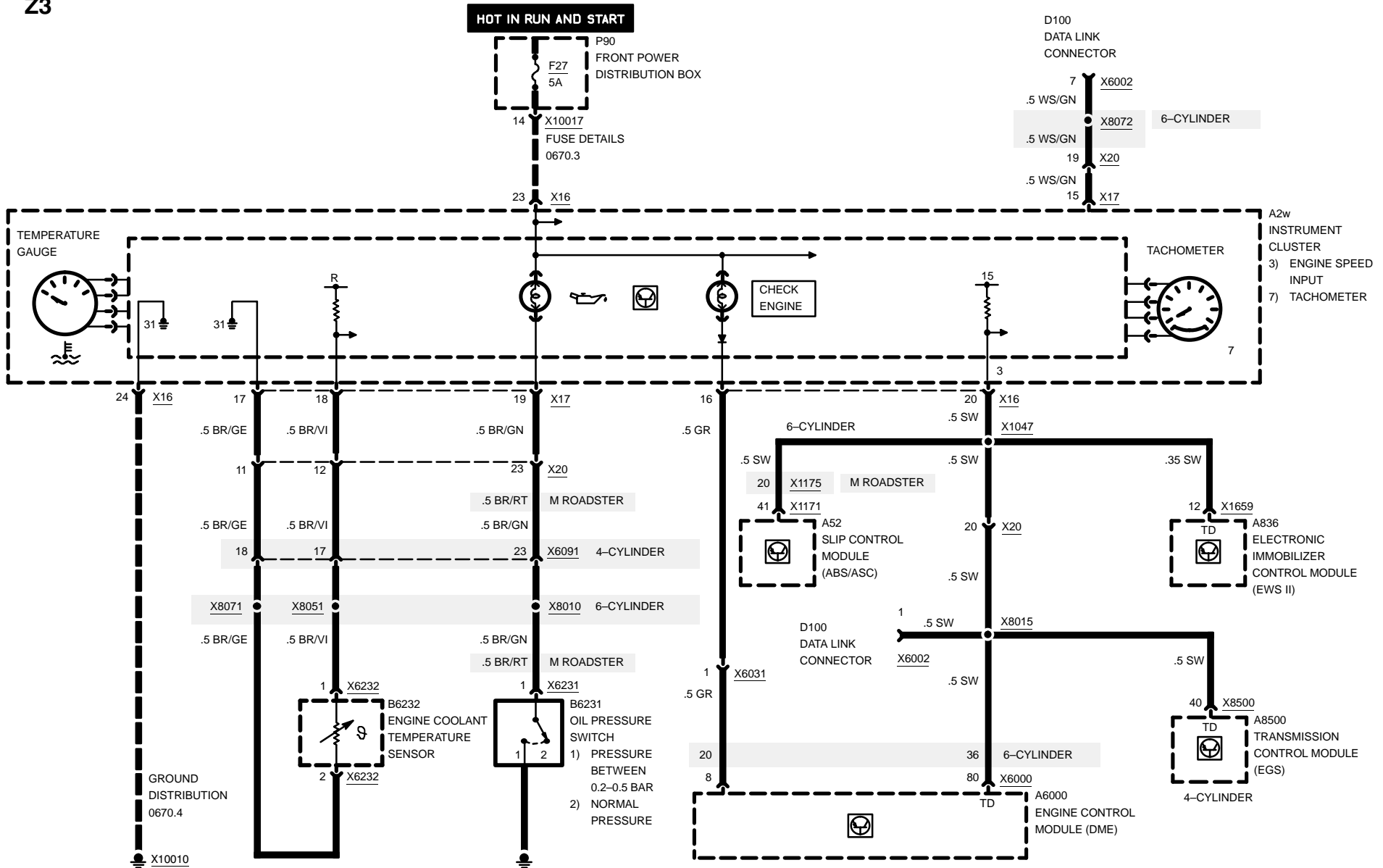

04/99

6211.0-02

1998

INSTRUMENT CLUSTER – ABS AND ASC INDICATORS

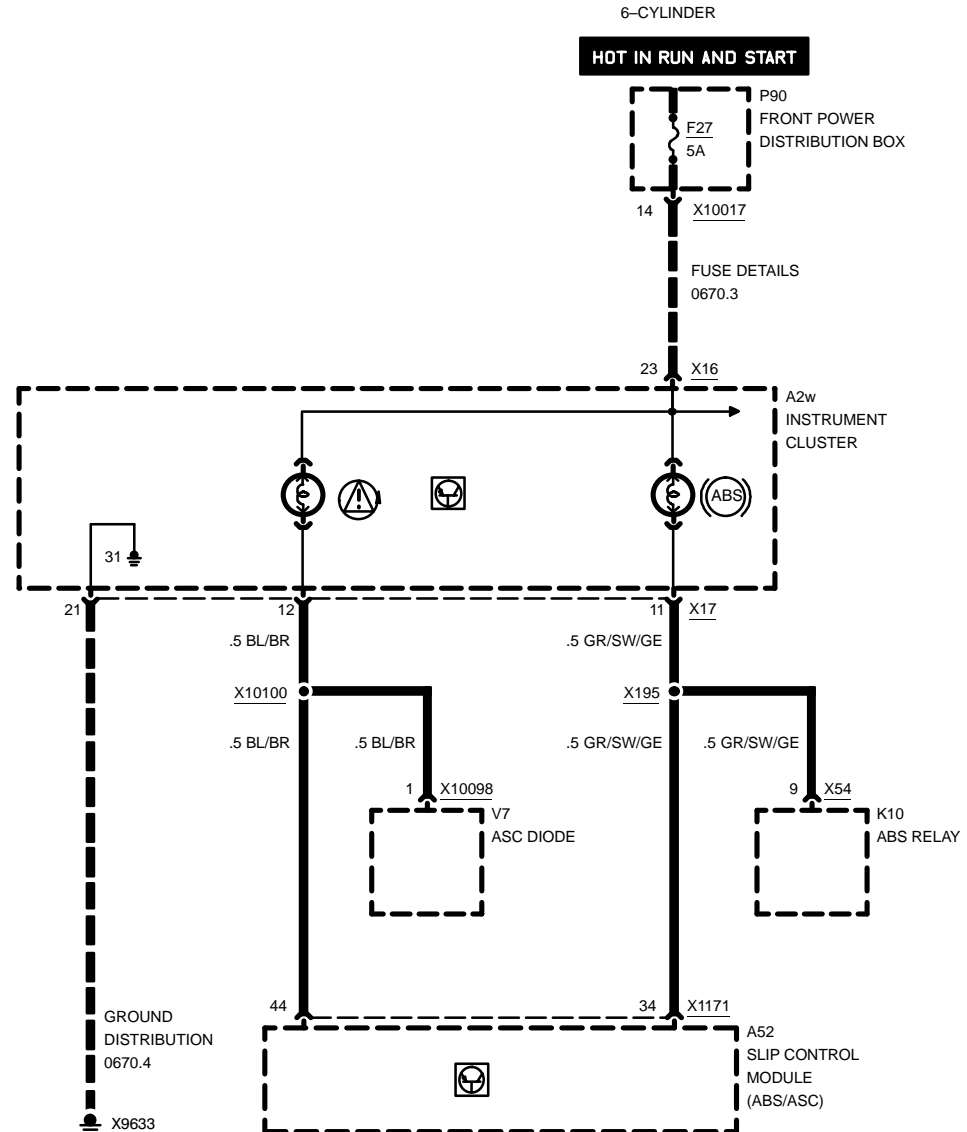
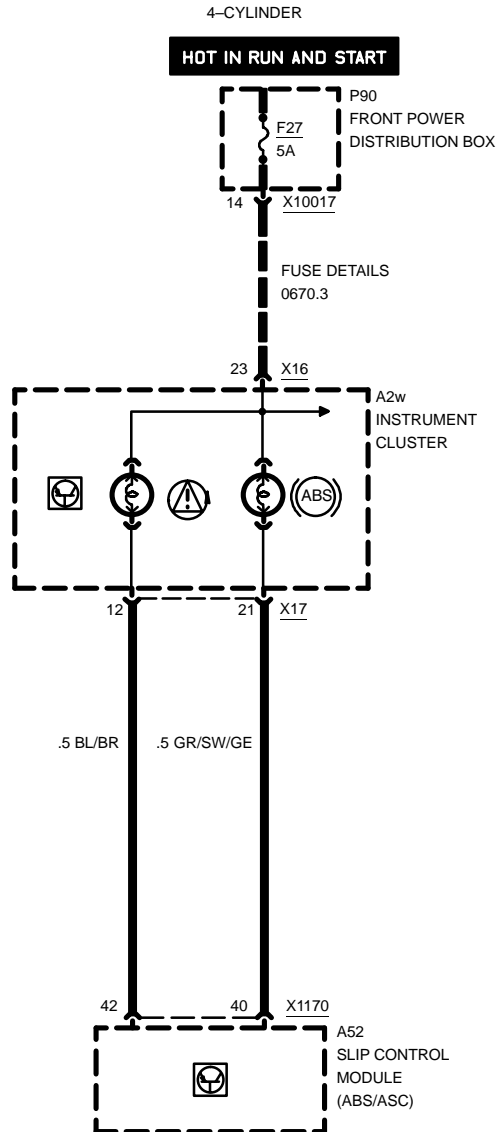

INSTRUMENT CLUSTER

INSTRUMENT CLUSTER – ABS AND ASC INDICATORS

M ROADSTER

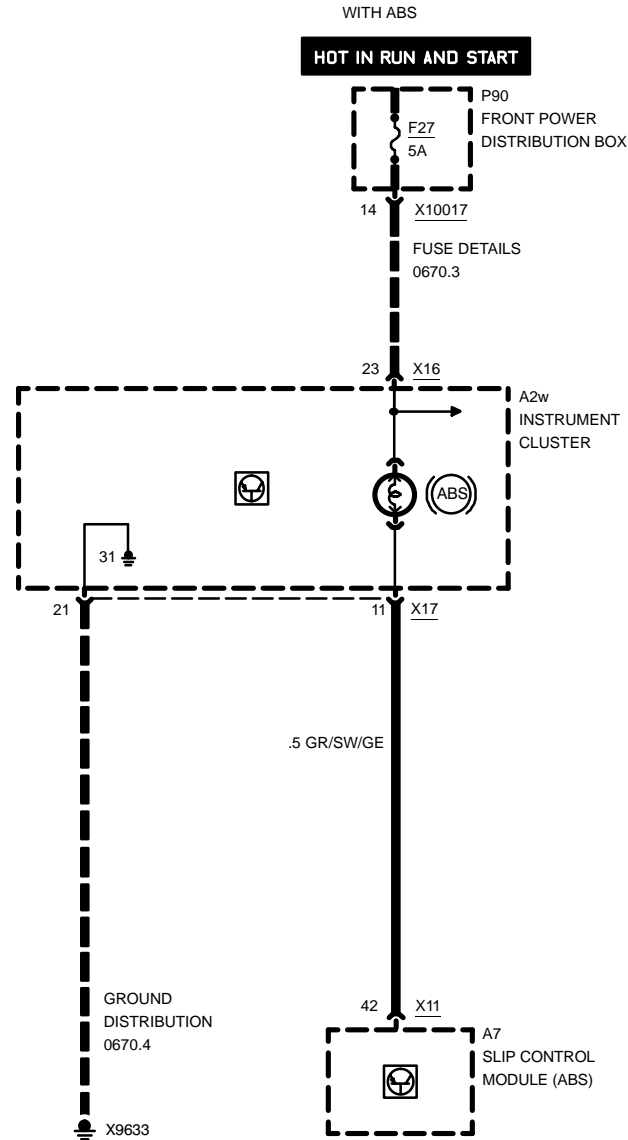
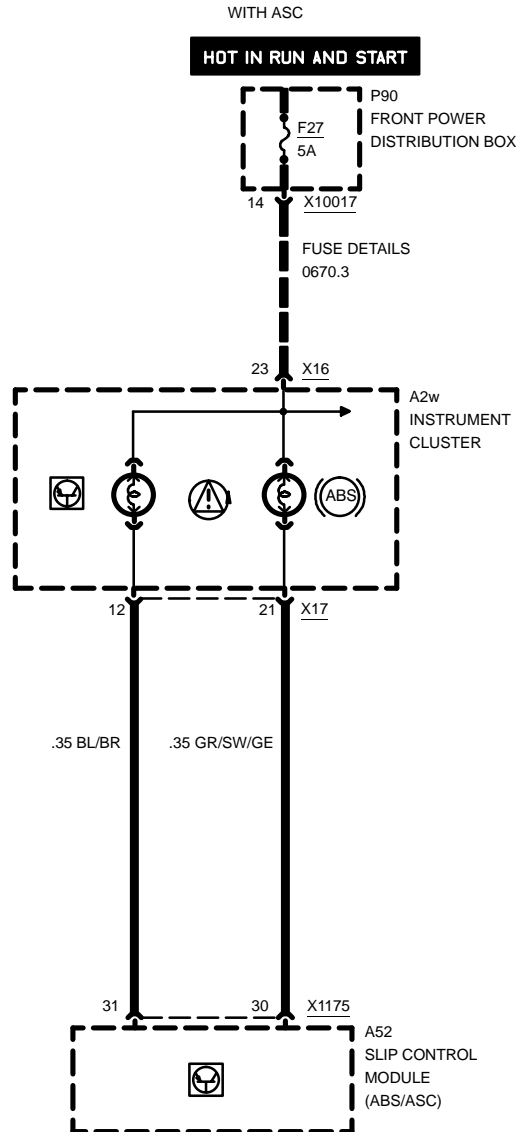



INSTRUMENT CLUSTER

INDICATORS

Z3

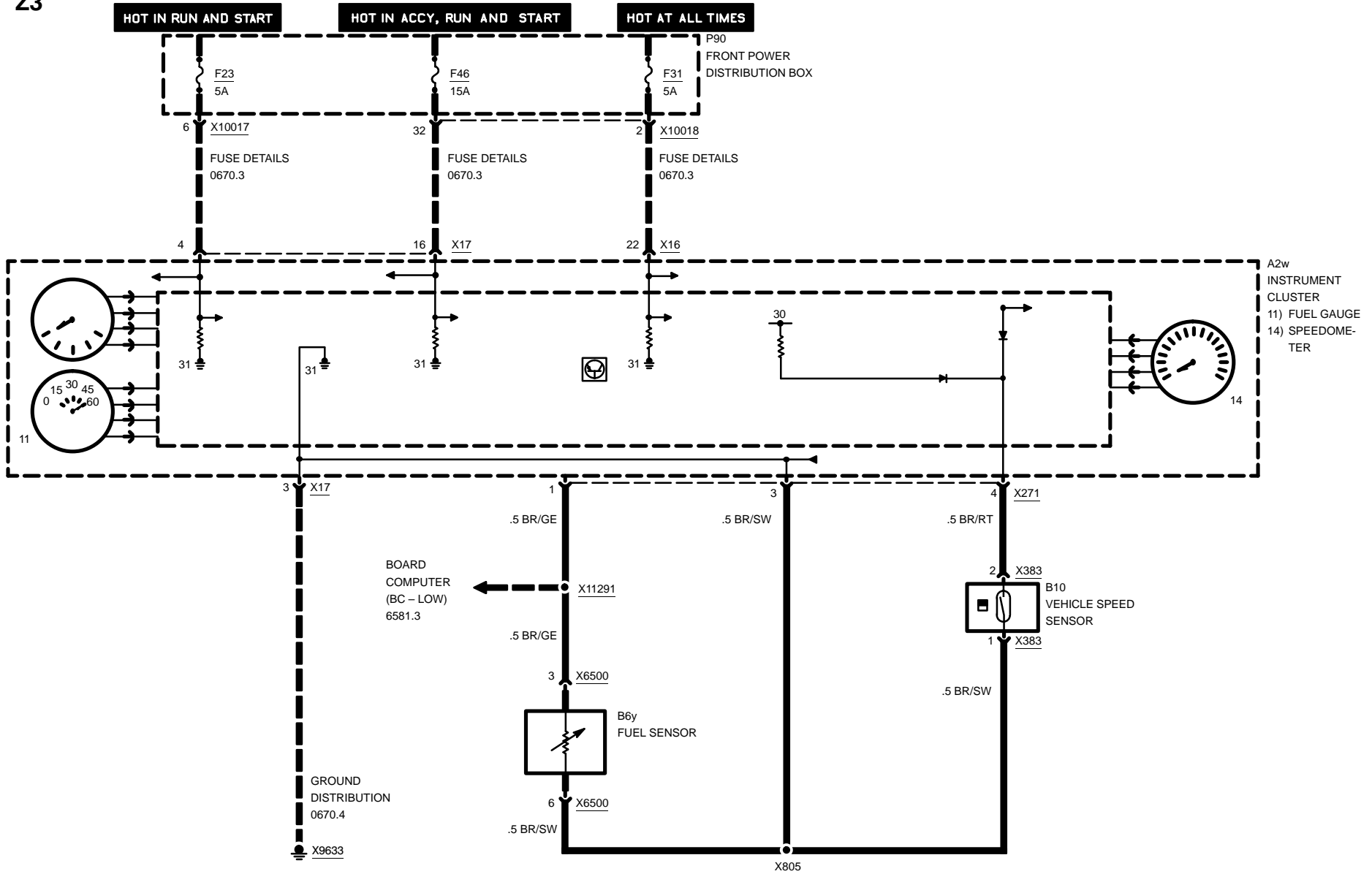



Z3

INSTRUMENT CLUSTER

04/99

6211.0-06

1998

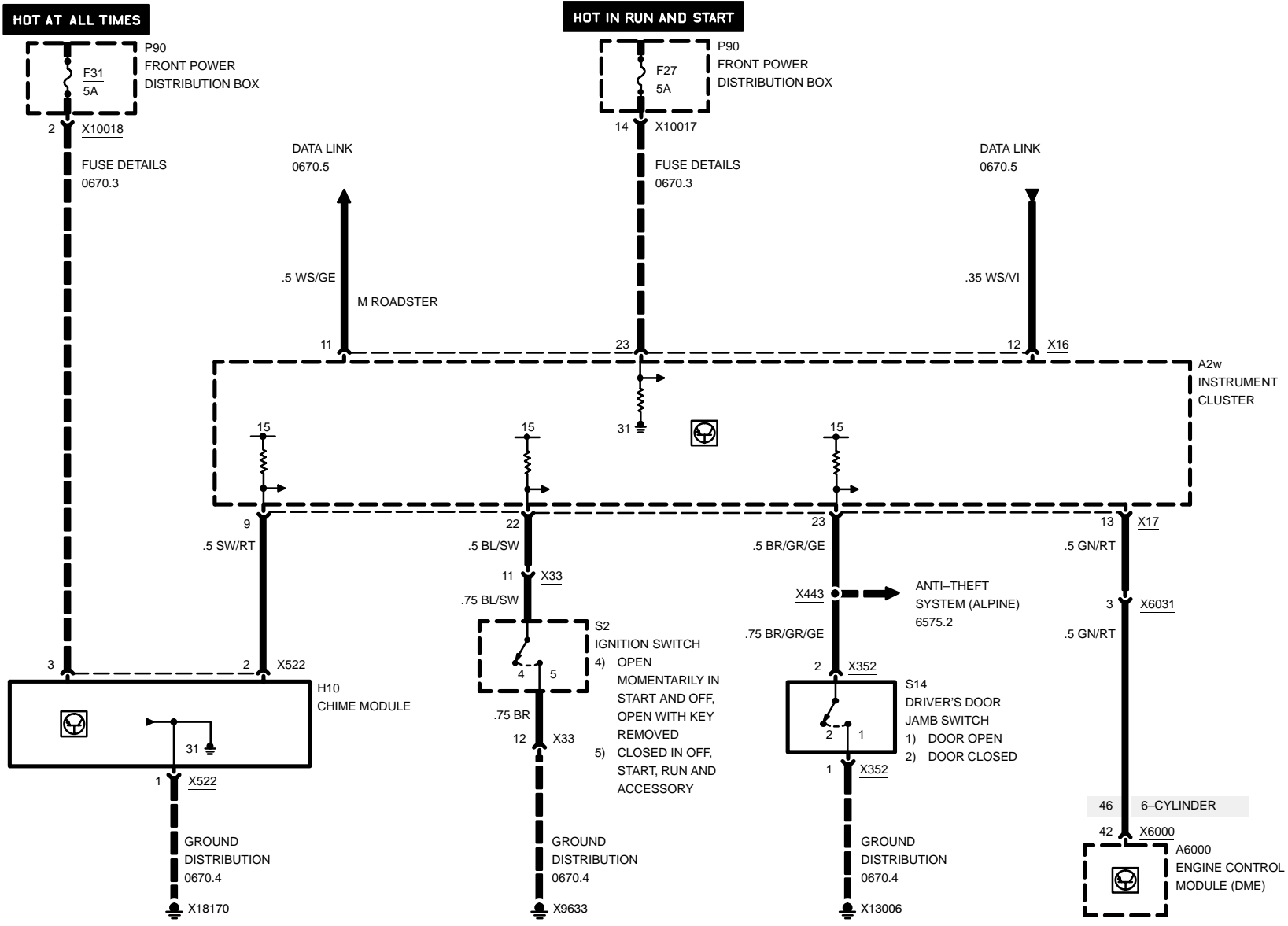



INSTRUMENT CLUSTER CONSOLE INSTRUMENTS

M ROADSTER

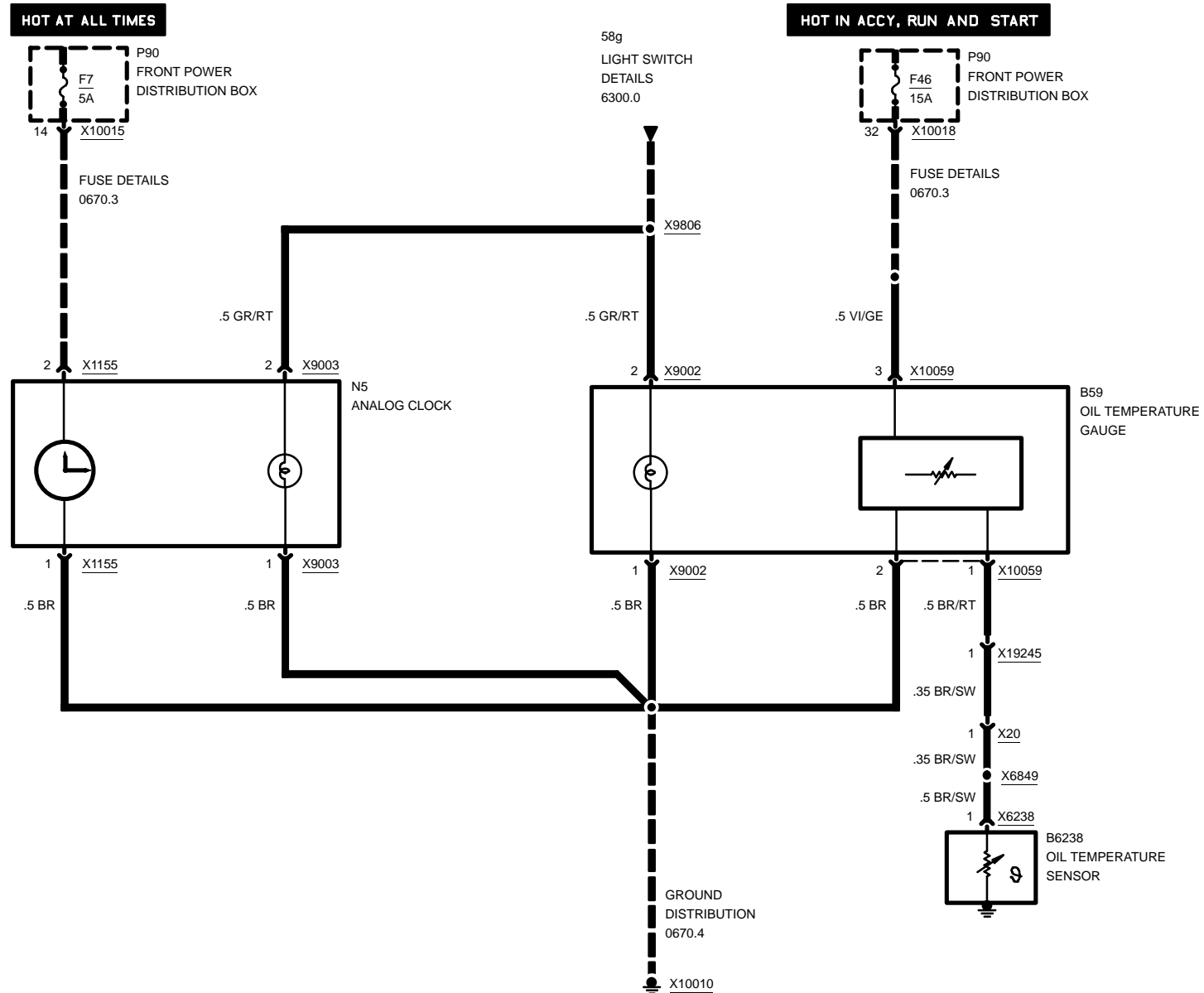

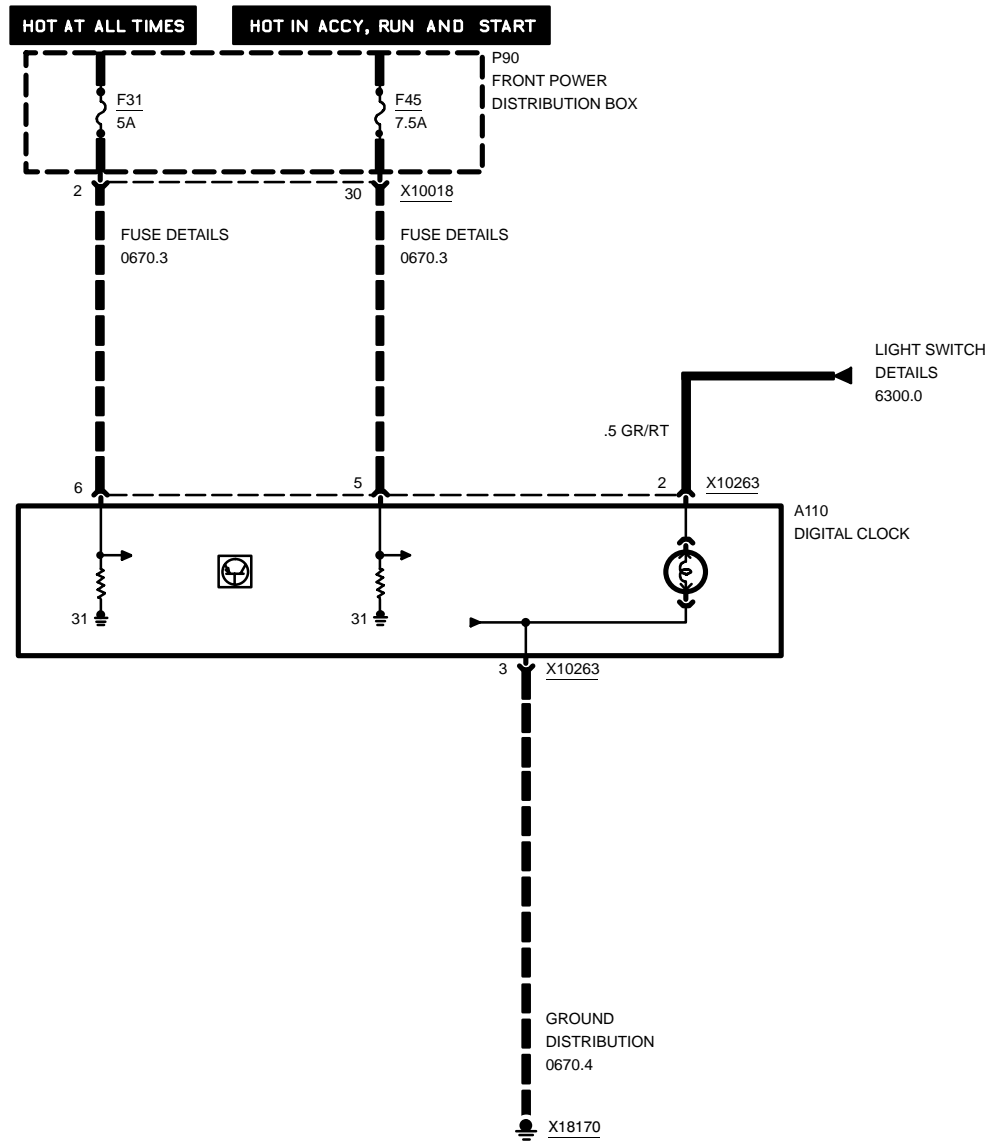

6300.0 LIGHT SWITCH DETAILS

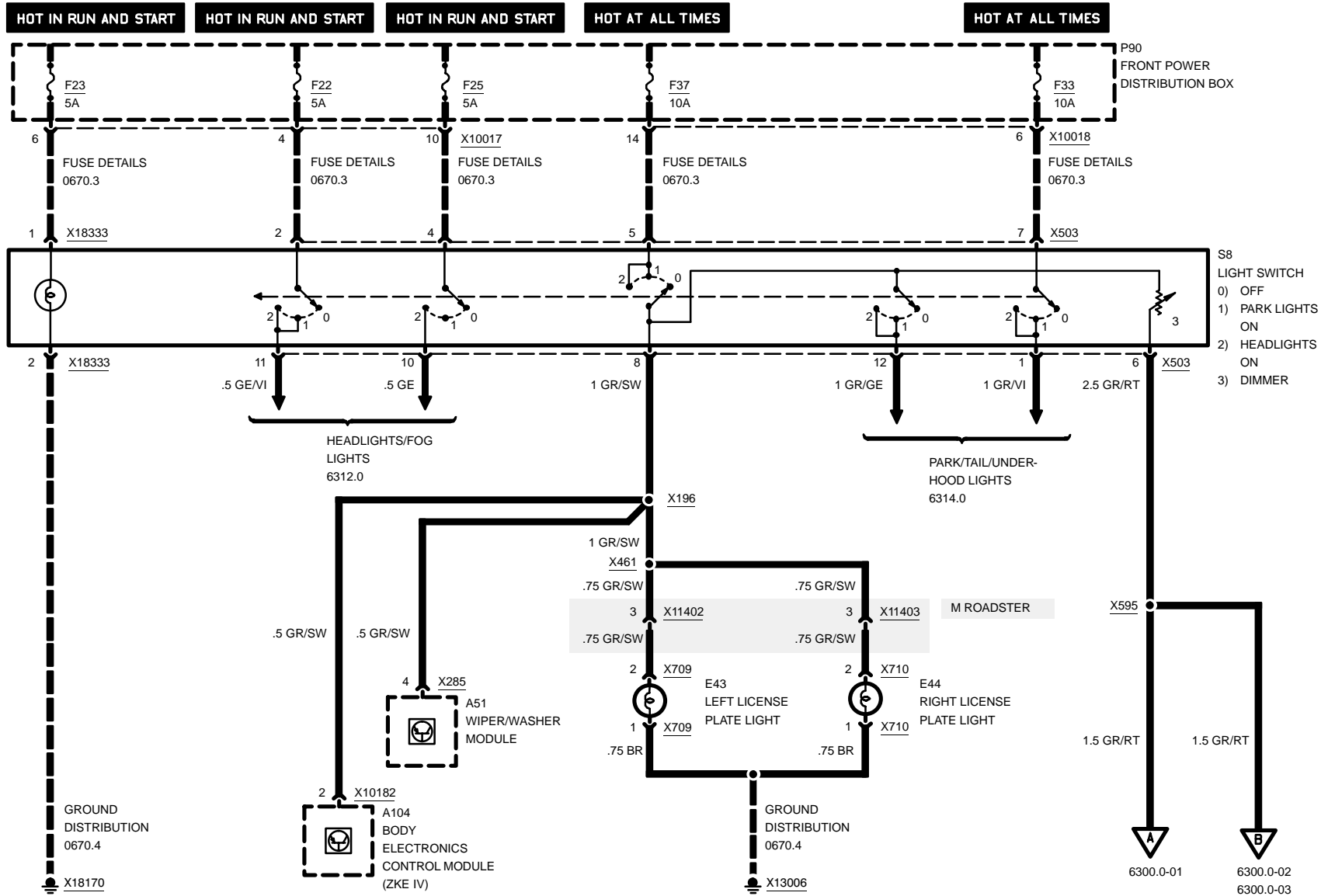



LIGHT SWITCH DETAILS

M ROADSTER

Z3

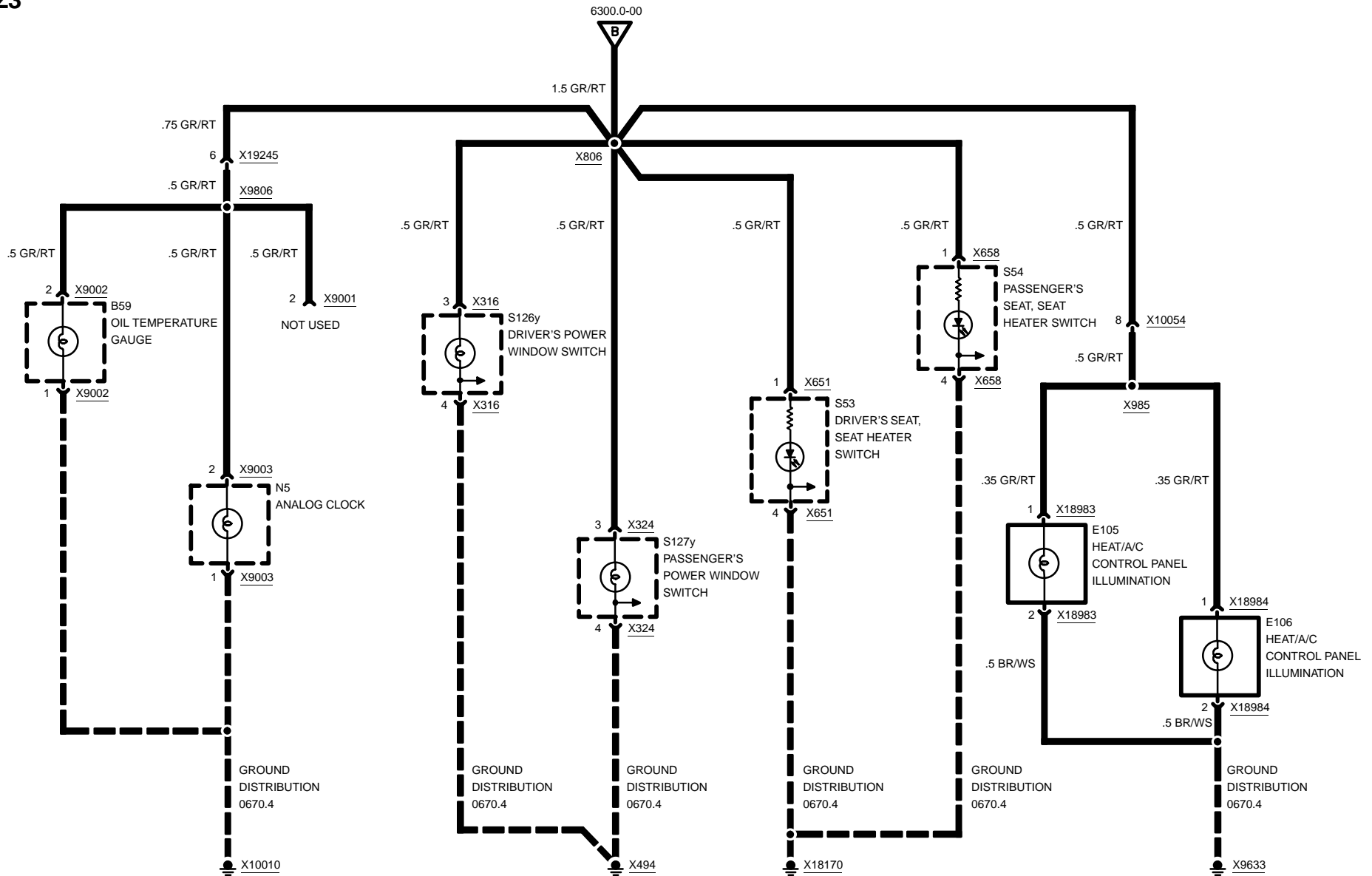

04/99

6300.0-03

1998



6312.0 HEADLIGHTS/FOG LIGHTS

Z3

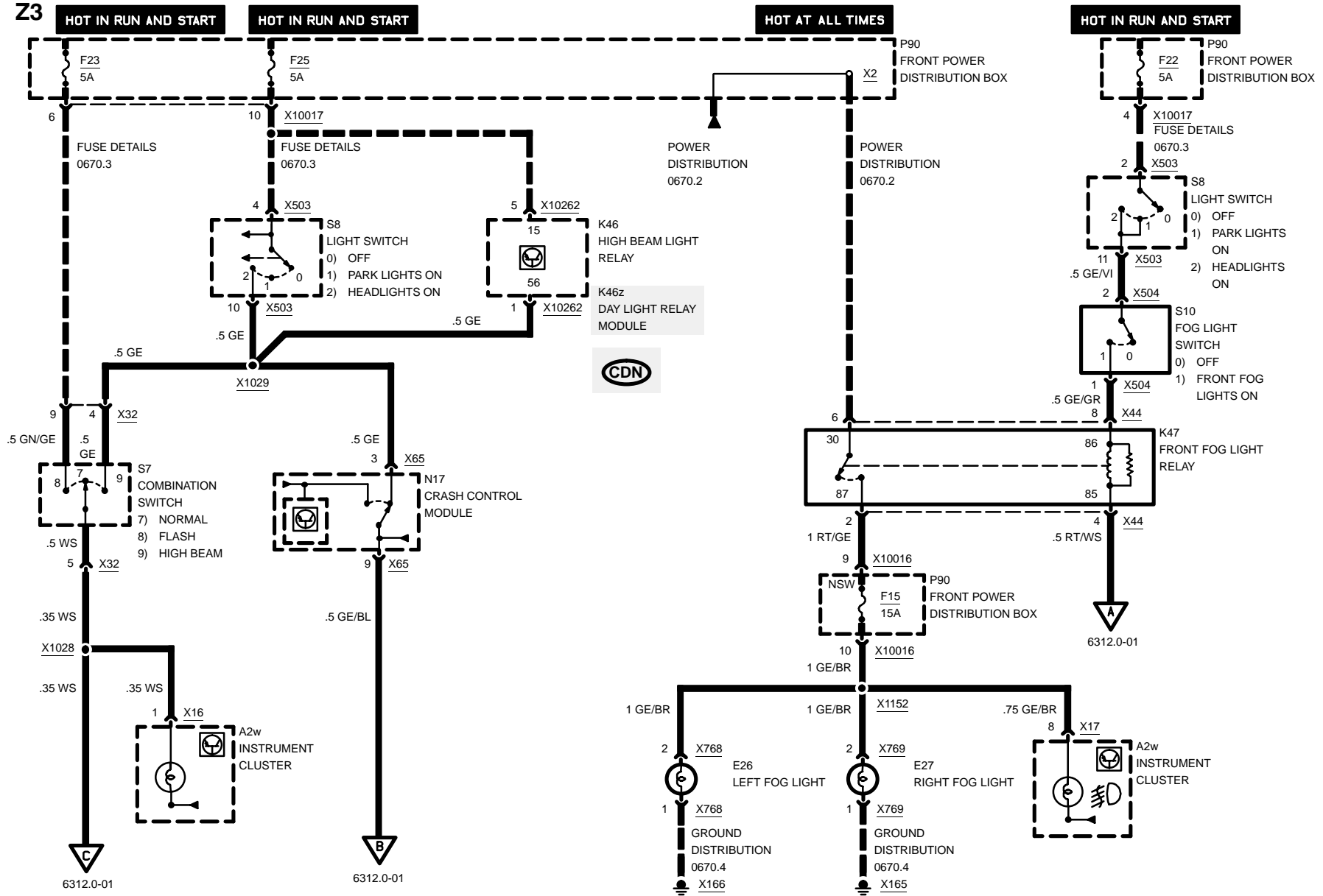

04/99

6312.0-00

1998

HEADLIGHTS/FOG LIGHTS

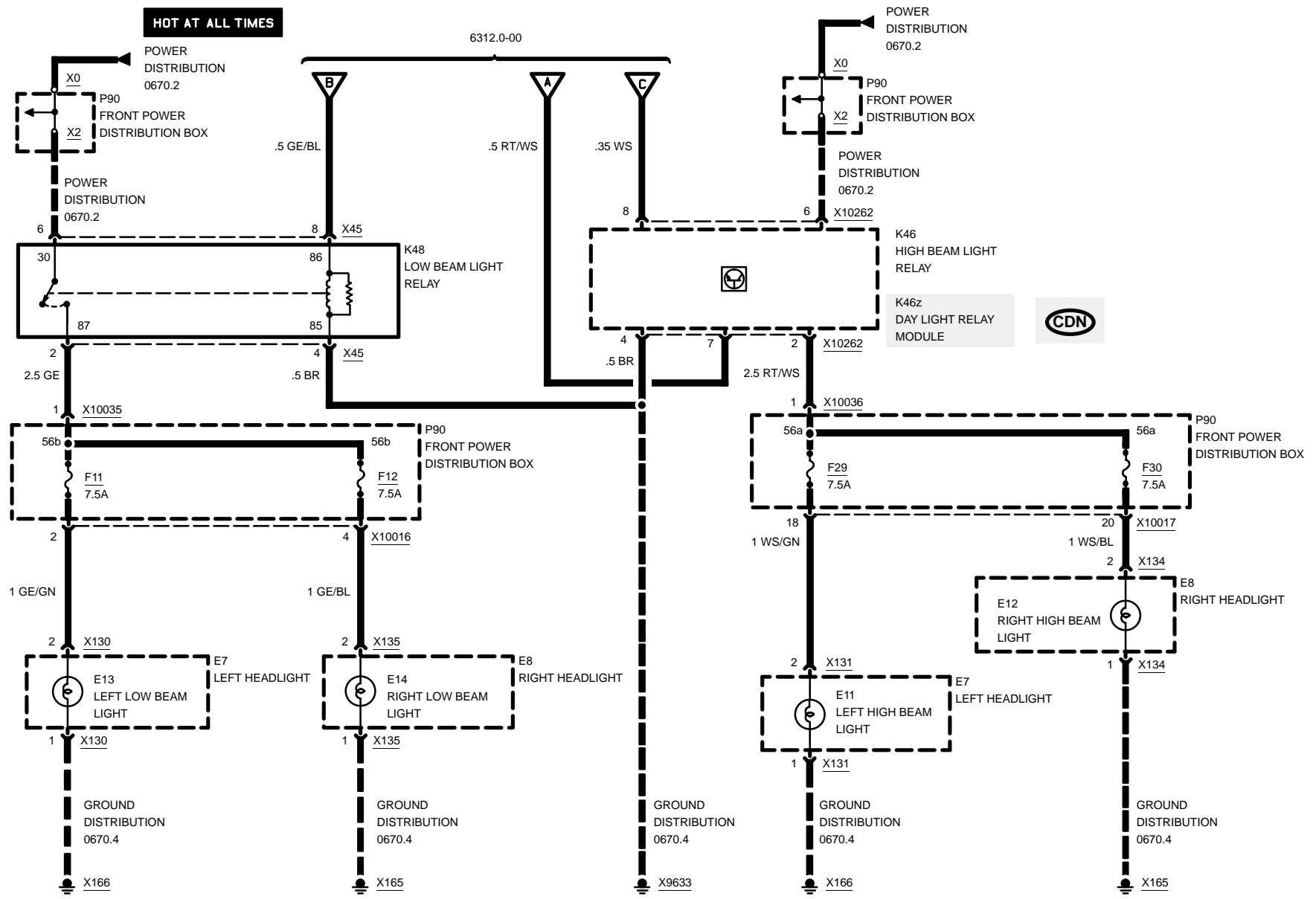

6313.0 TURN/HAZARD LIGHTS

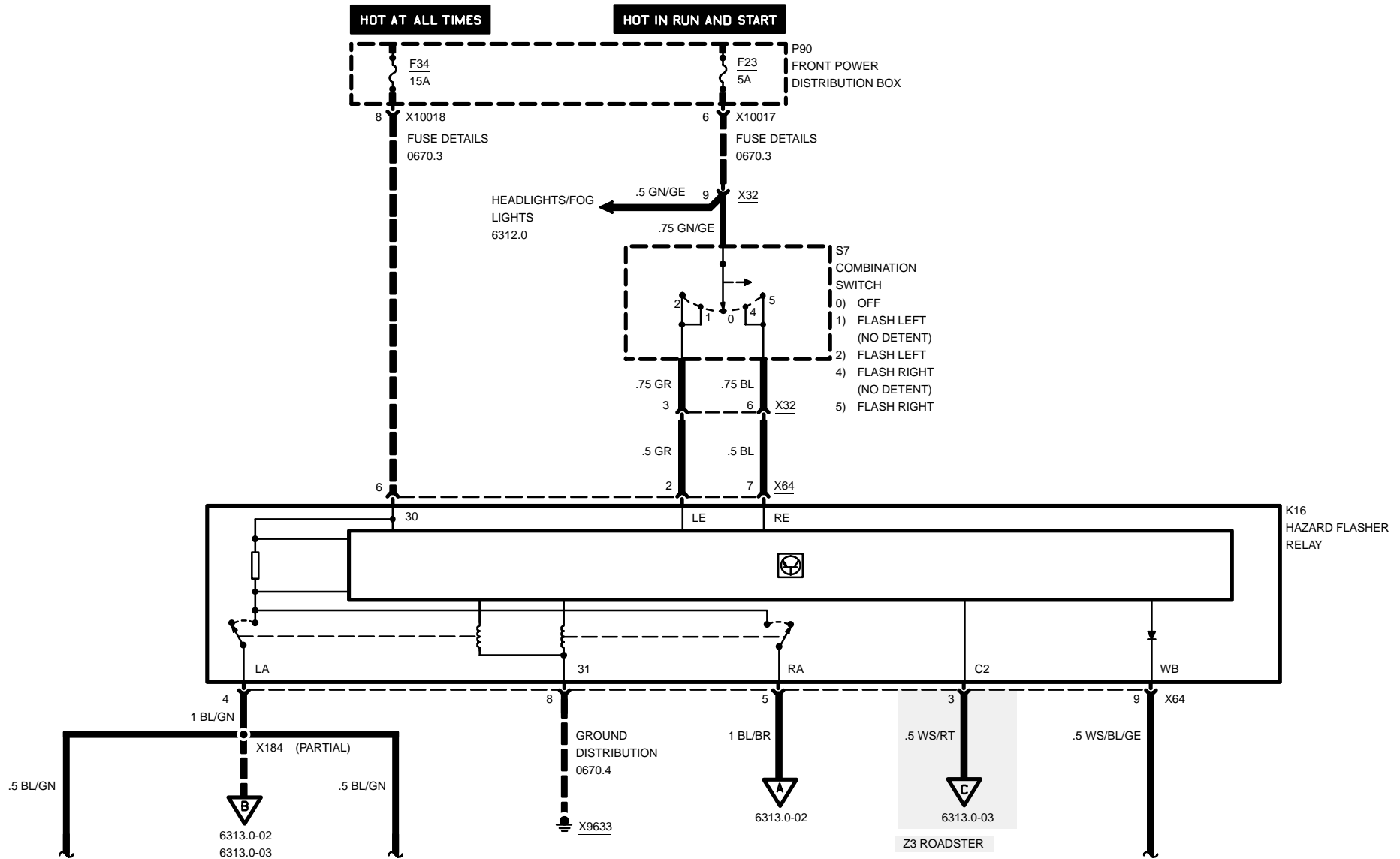

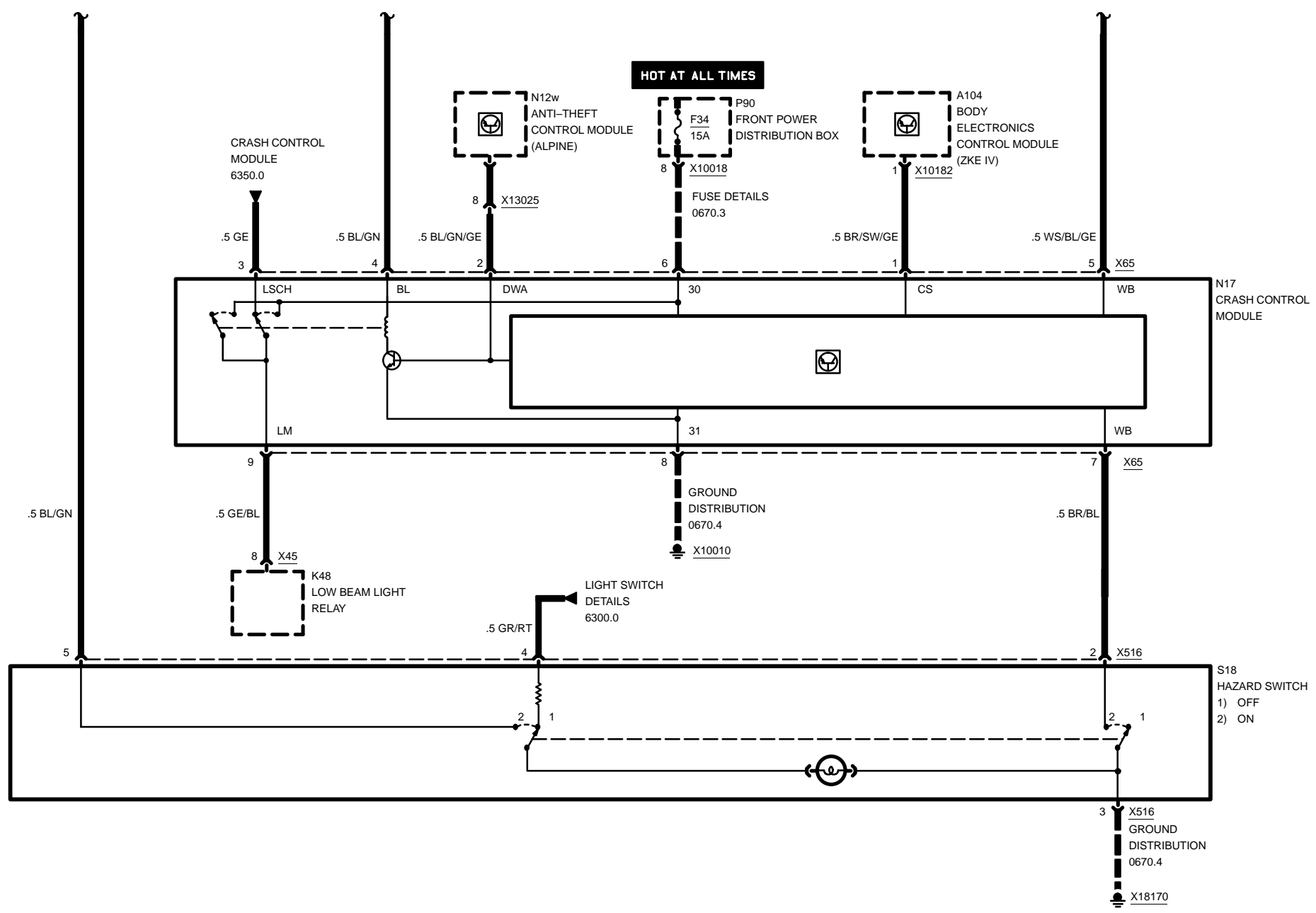

TURN/HAZARD LIGHTS

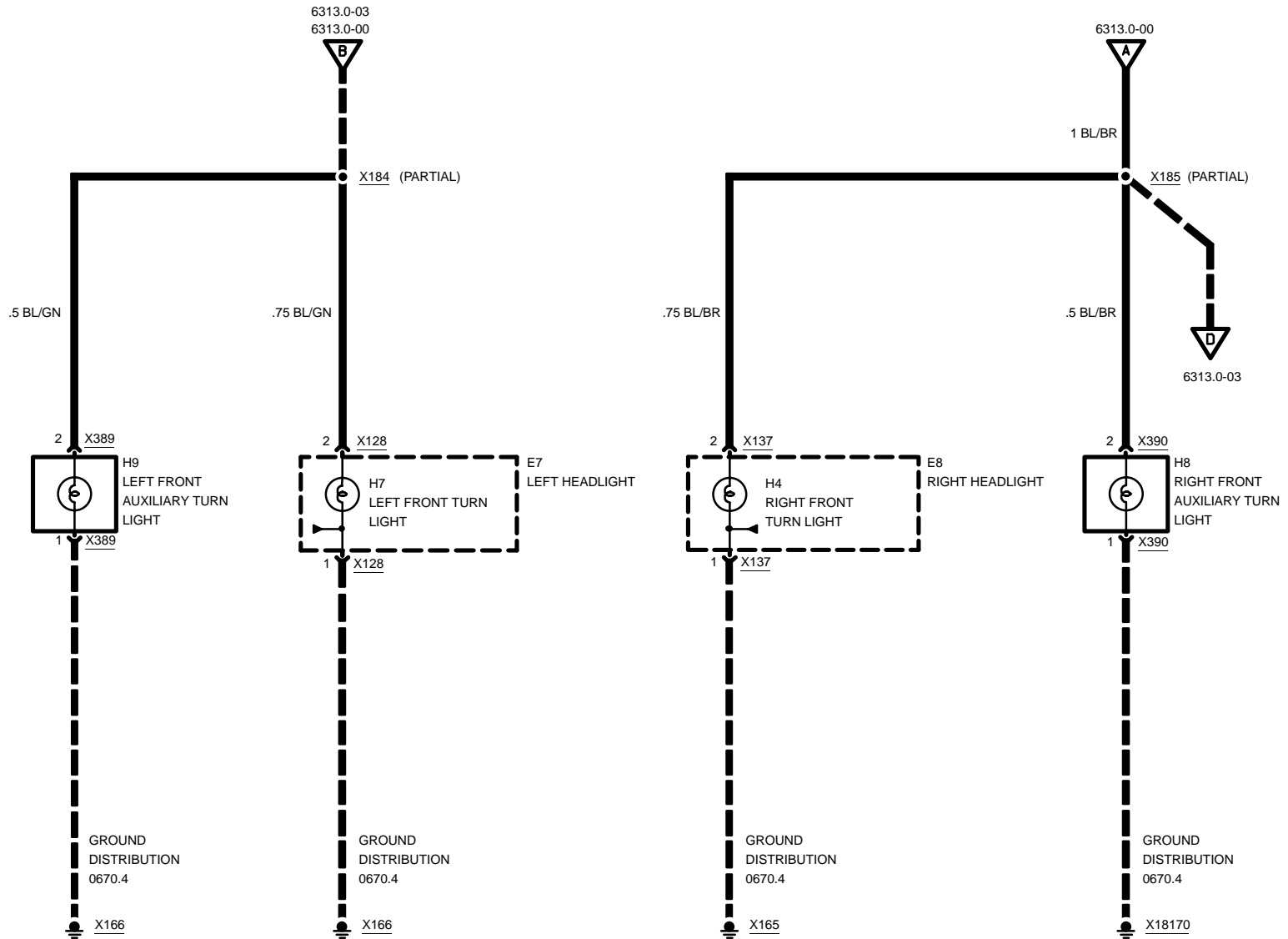



TURN/HAZARD LIGHTS

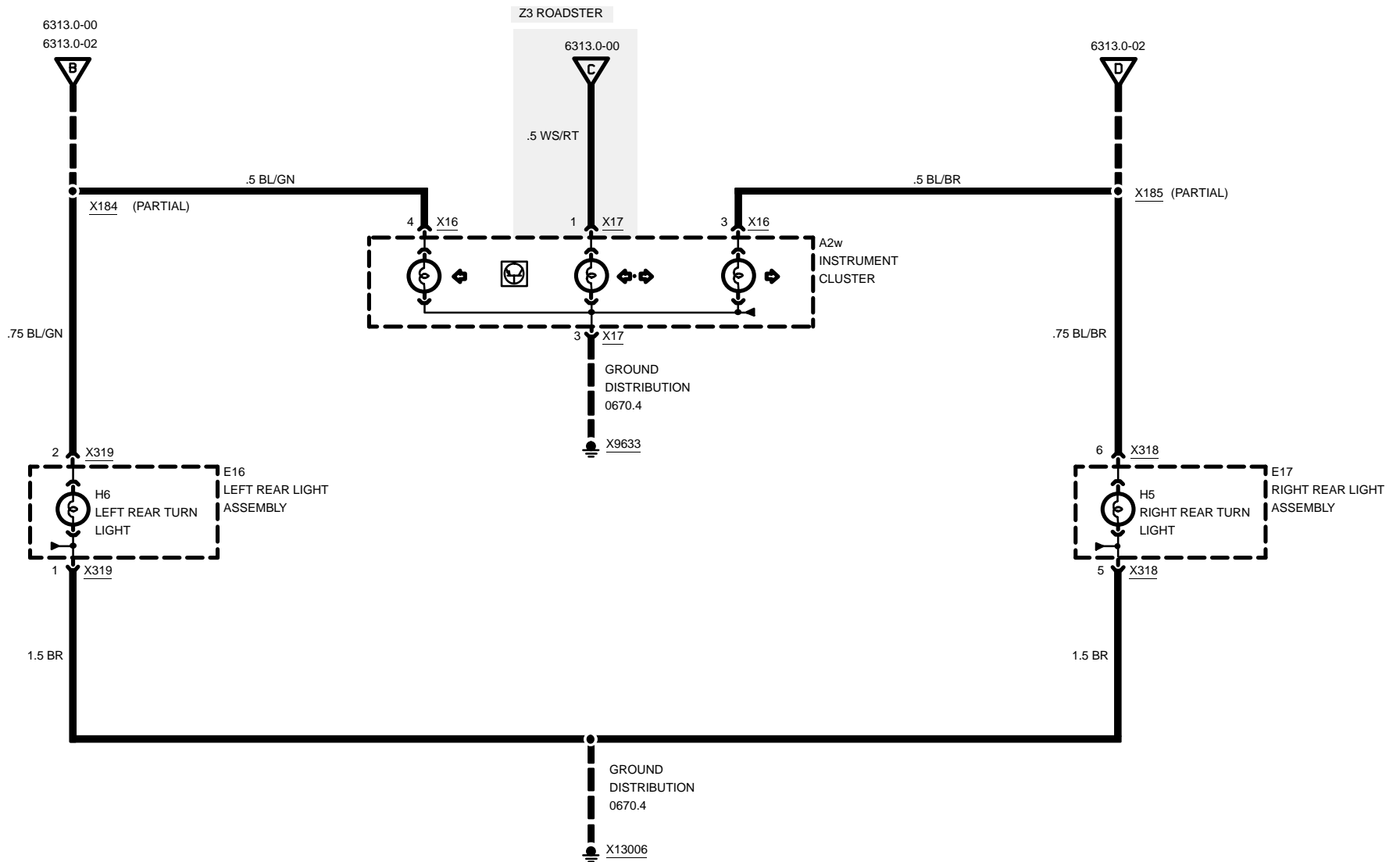



6314.0 PARK/TAIL/UNDERHOOD LIGHTS

Z3

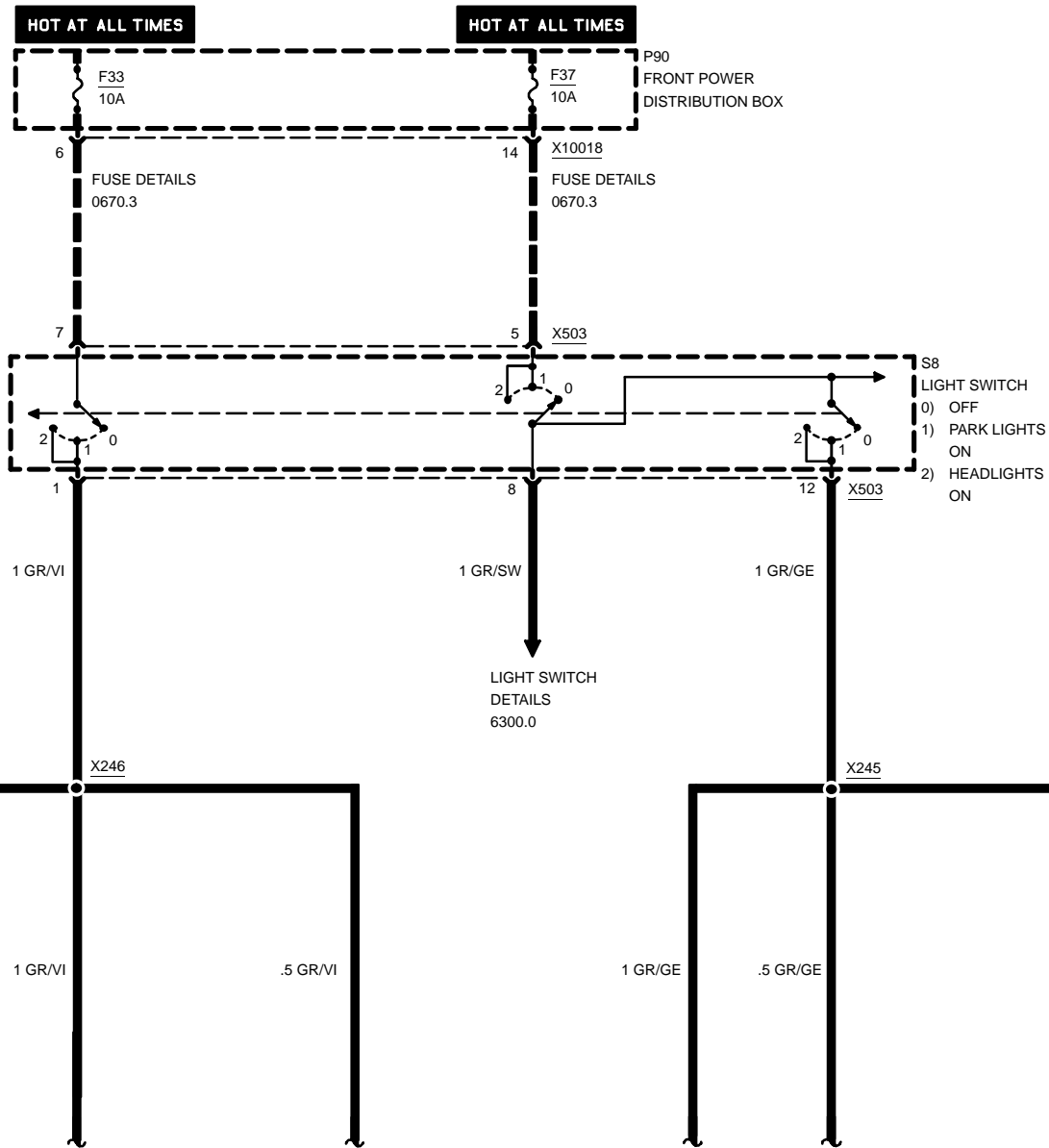

04/99

6314.0-00

1998

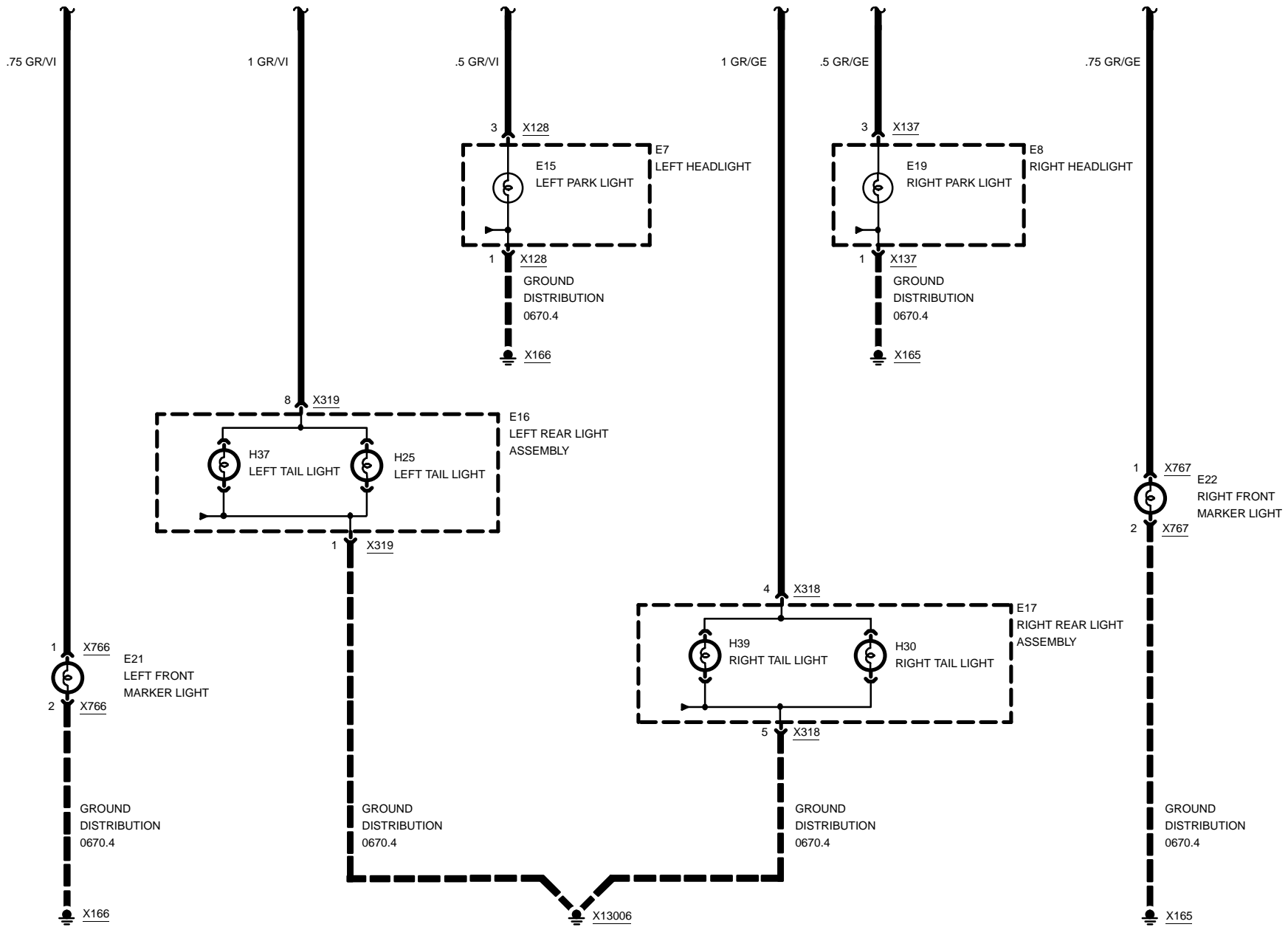



6320.0 LICENSE PLATE/LUGGAGE COMPARTMENT LIGHTS

Z3

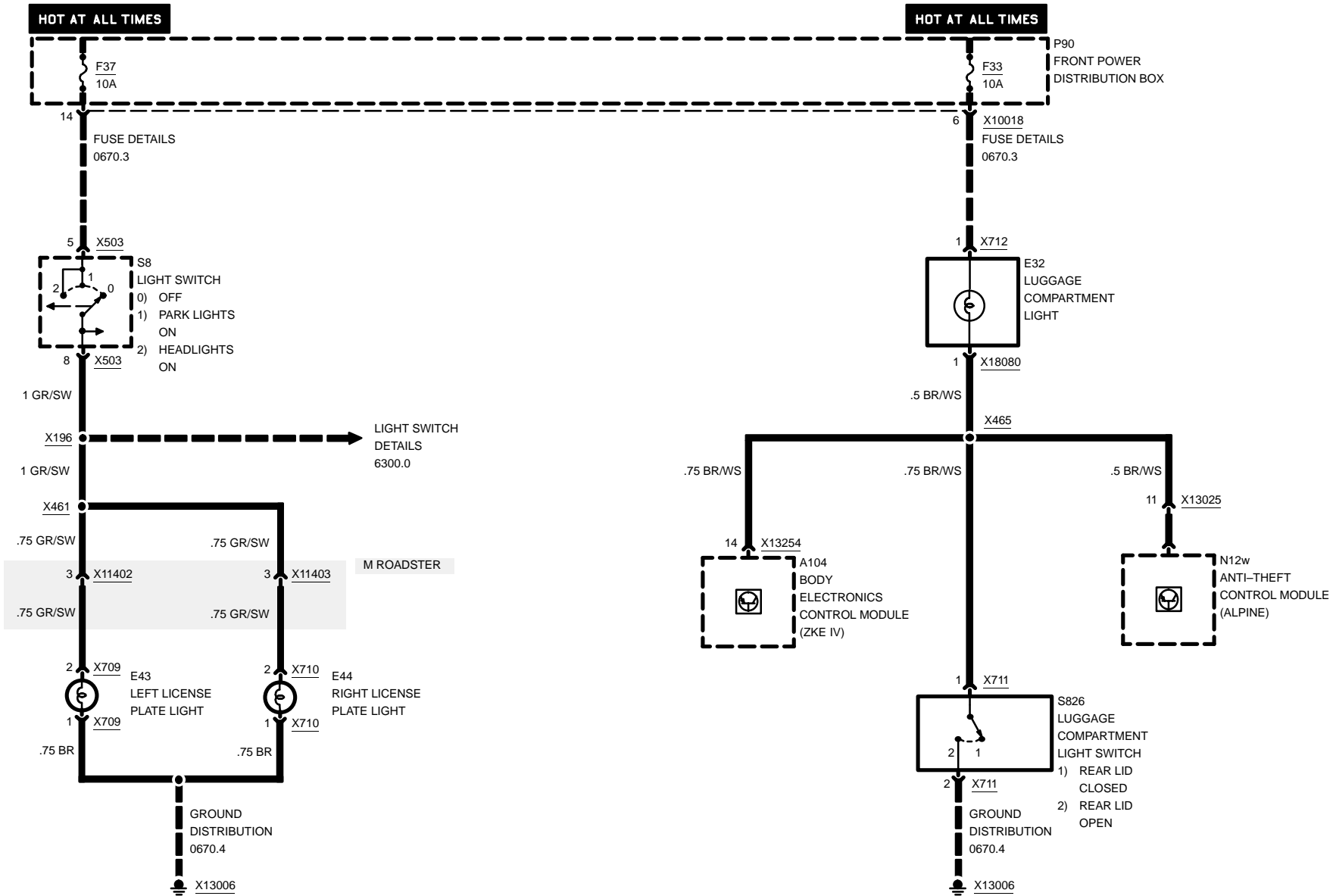

04/99

6320.0-00

1998



6322.0 BACK UP LIGHTS

Z3

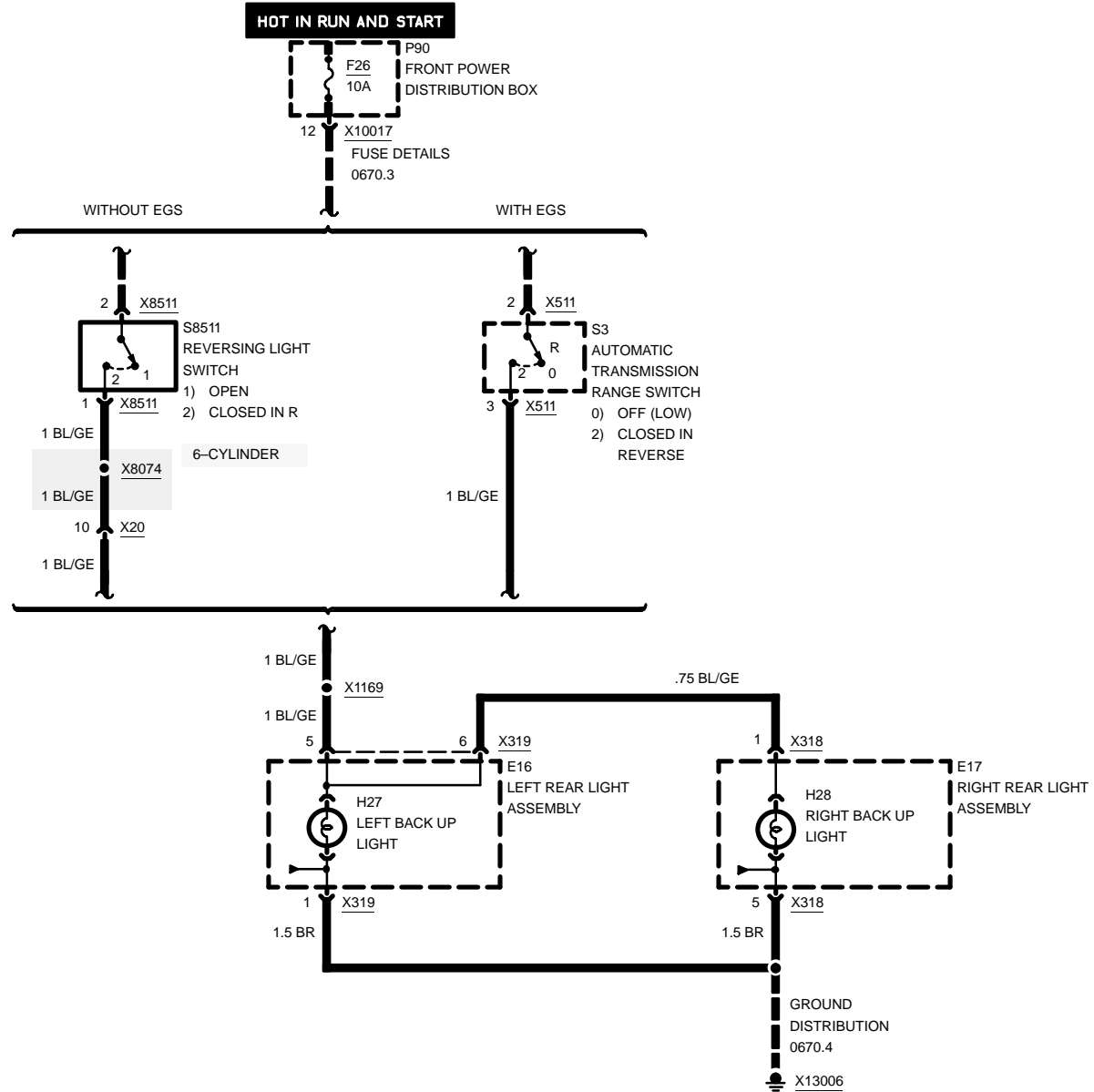

04/99

6322.0-00

1998

6325.0 BRAKE LIGHTS

Z3 ROADSTER

Z3

04/99

6325.0-00

1998

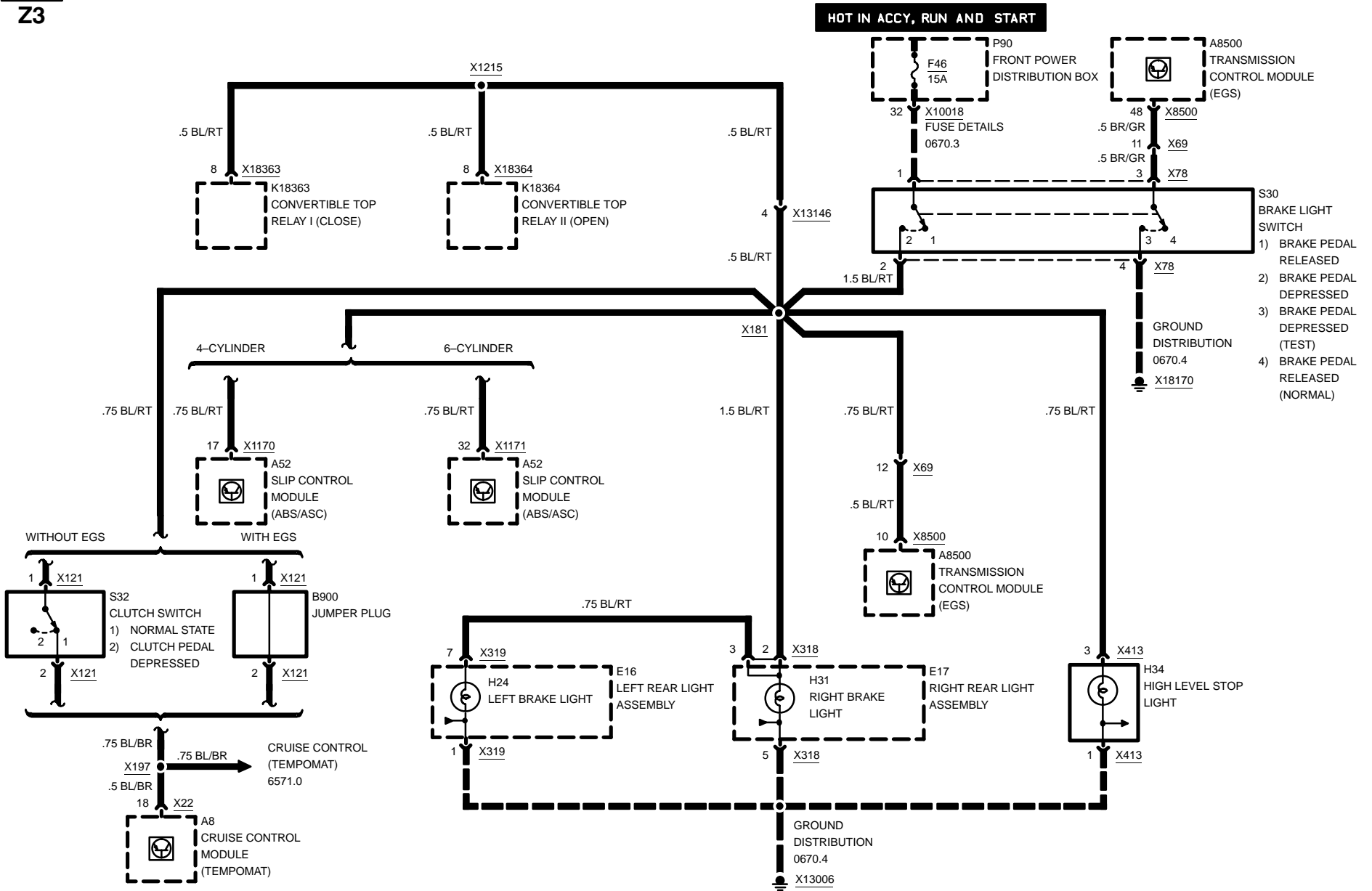

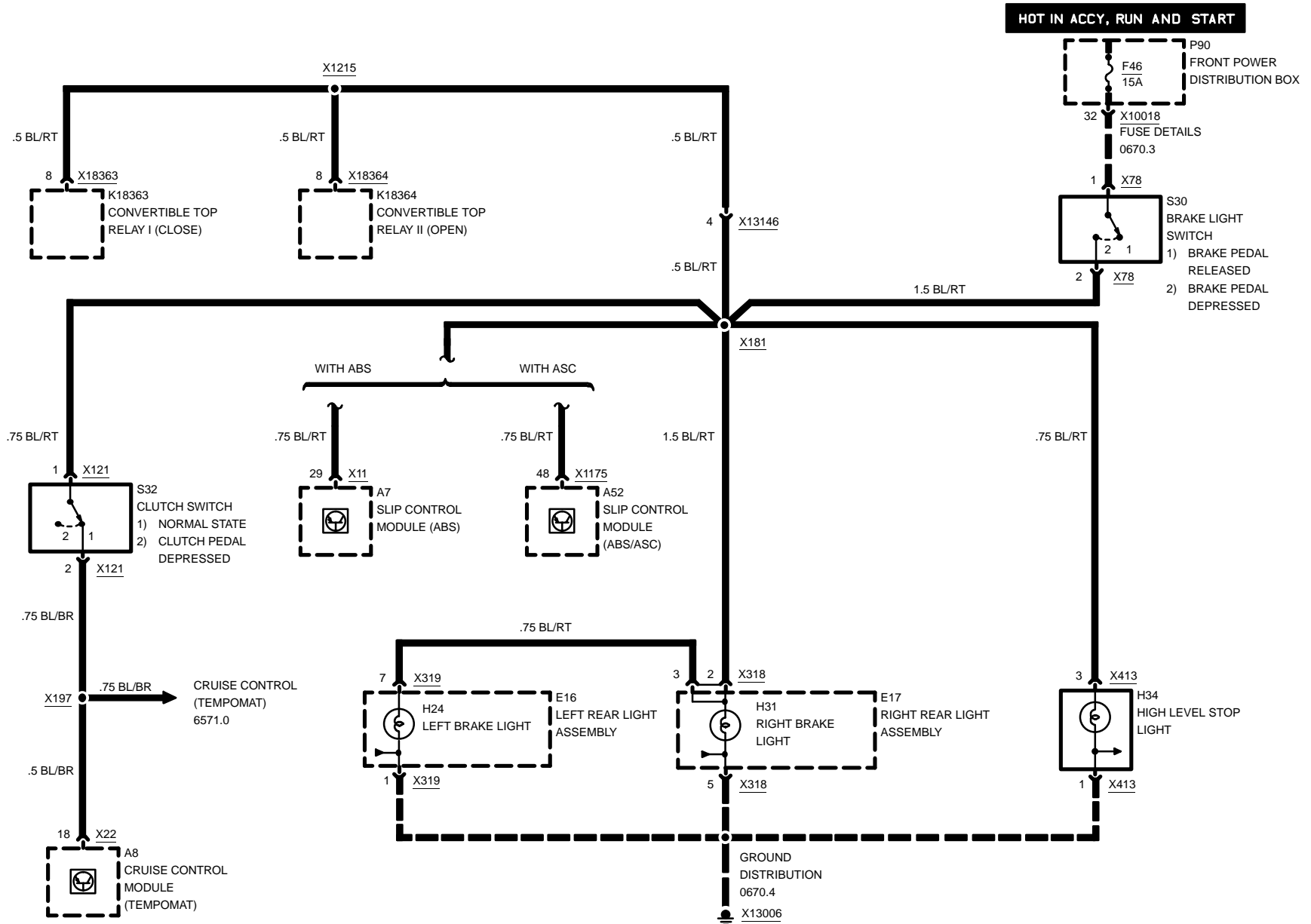

6330.3 INTERIOR LIGHTS

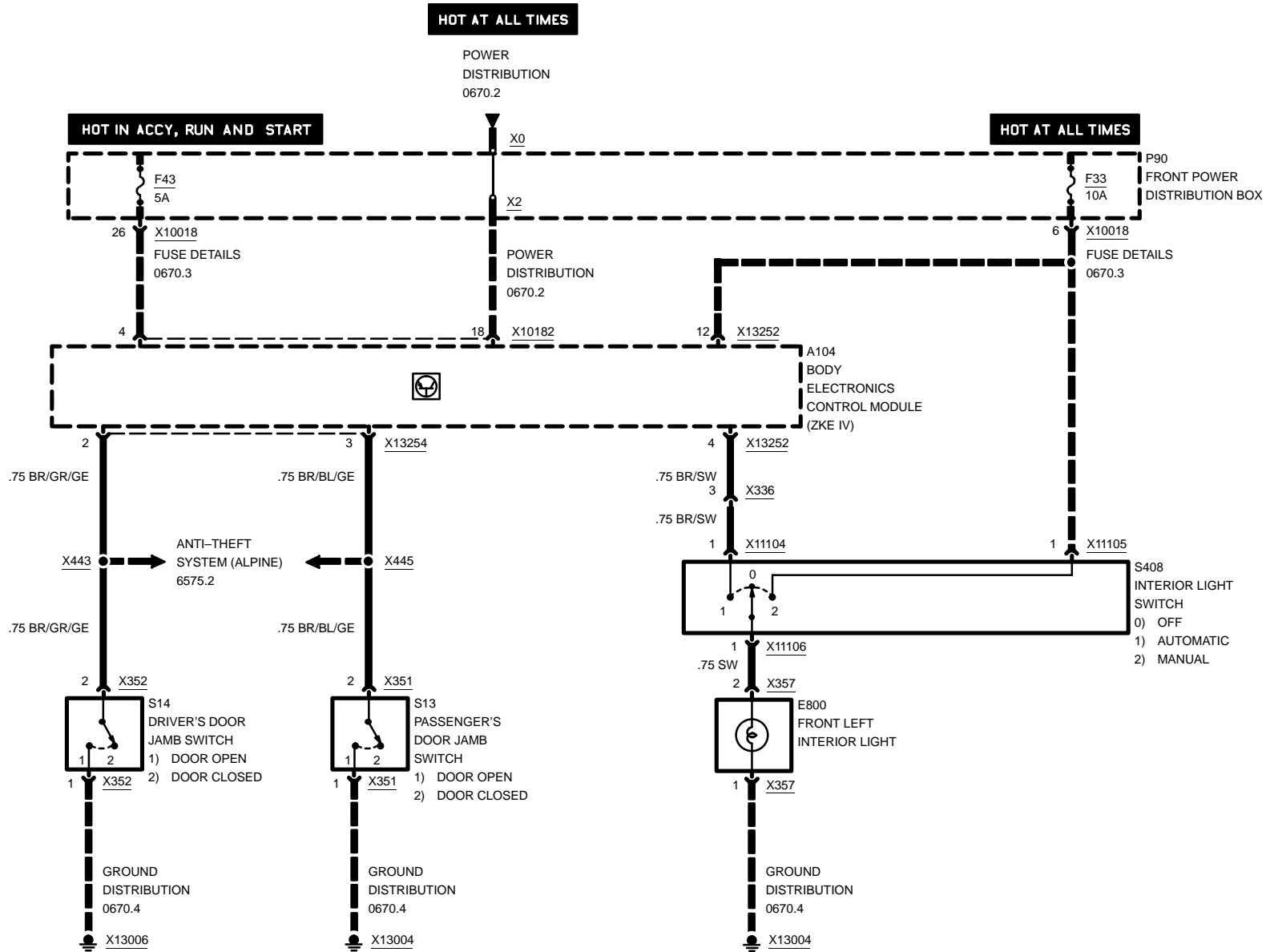

6332.0 INTERIOR ACCESSORIES

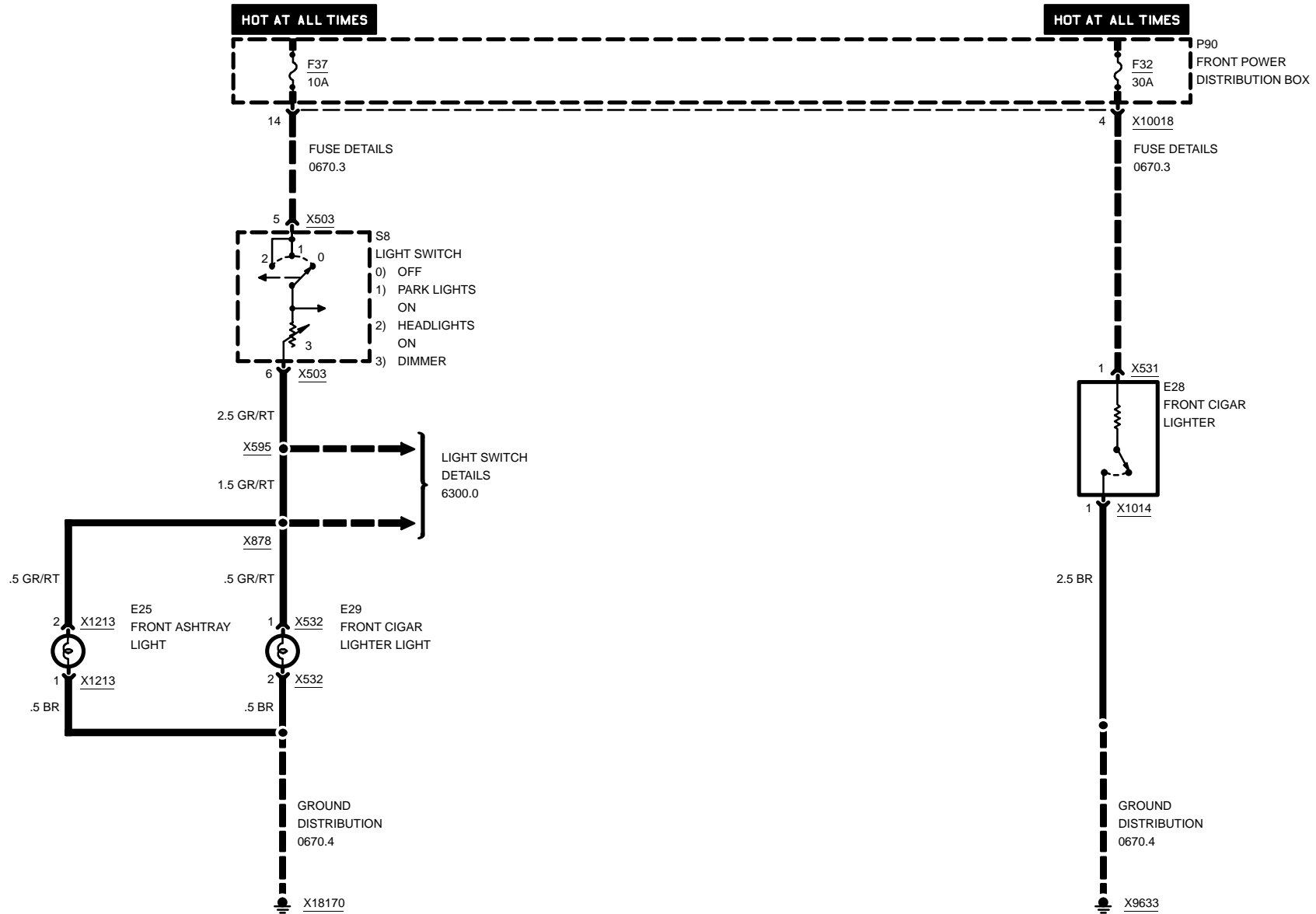



Z3

6350.0 CRASH CONTROL MODULE

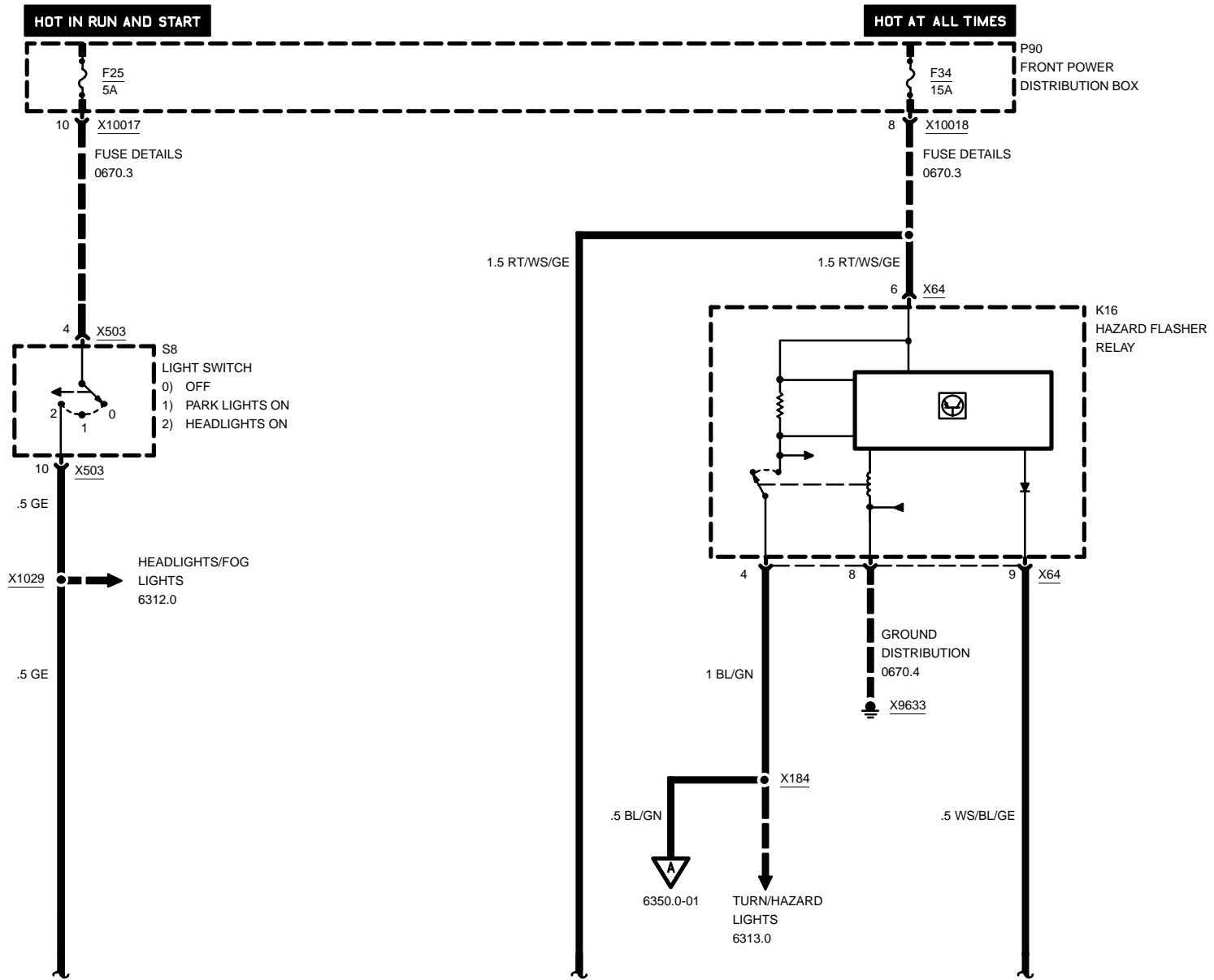

04/99

6350.0-00

1998

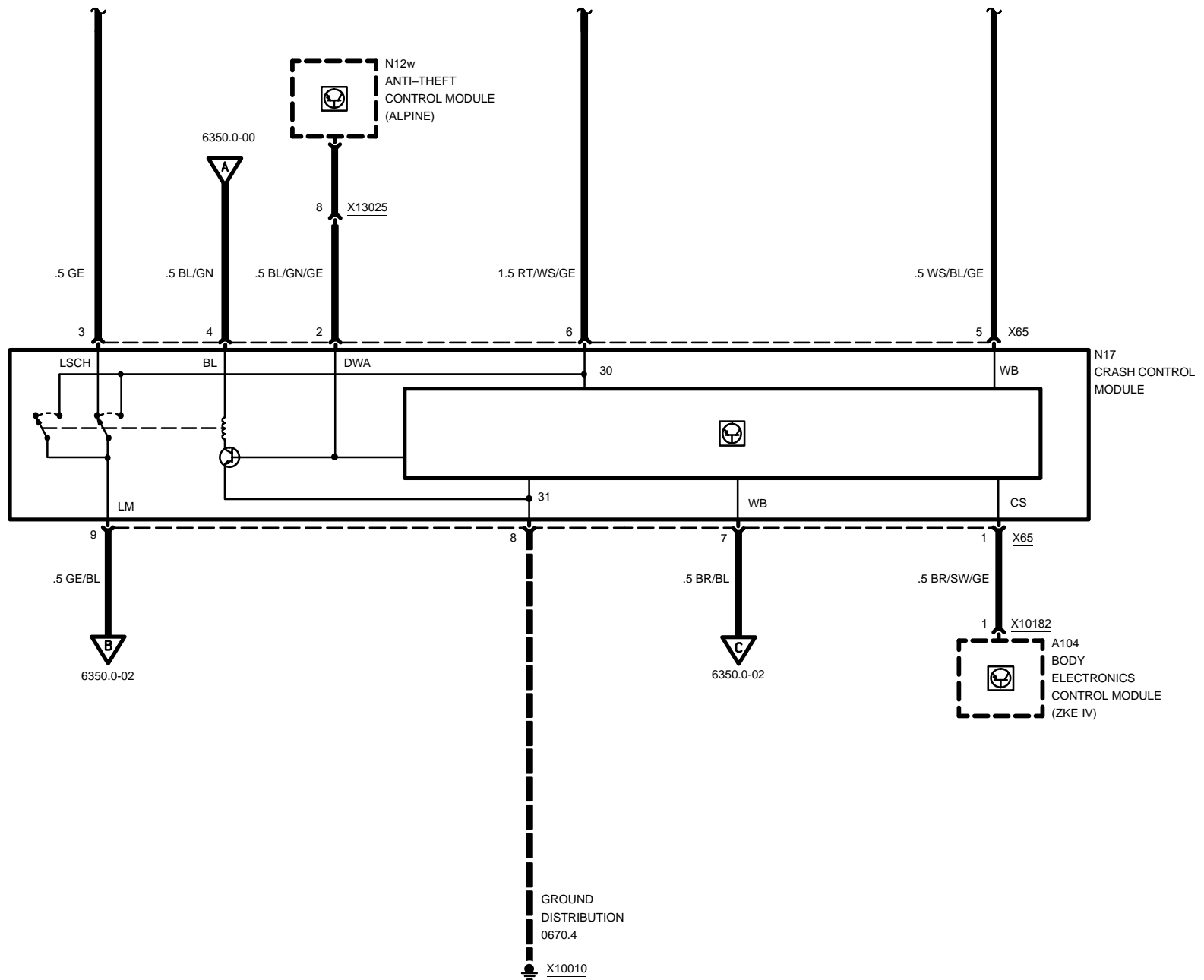



Z3

CRASH CONTROL MODULE

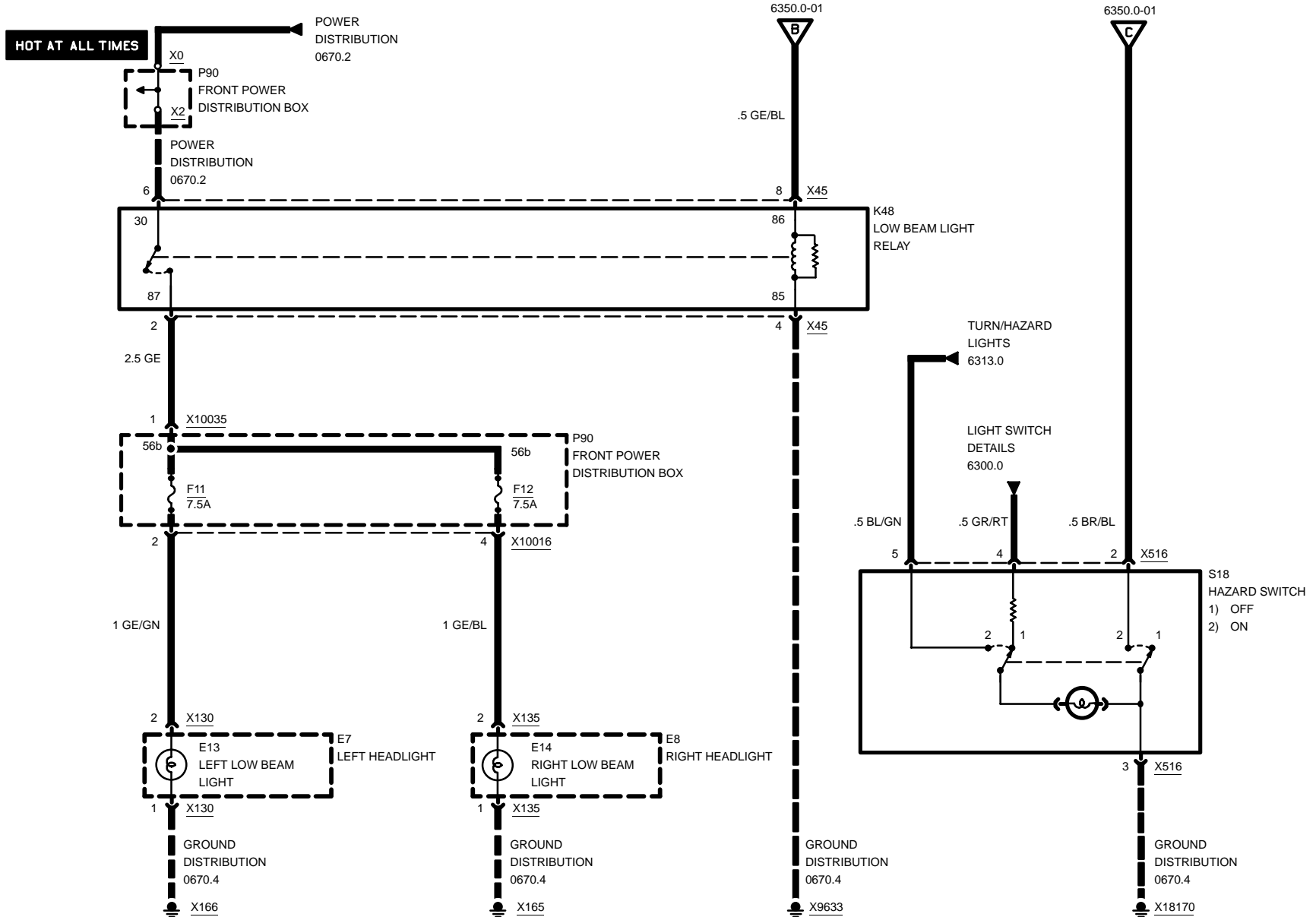

04/99

6350.0-02

1998



Z3

6424.0 REAR WINDOW DEFOGGER

EARLY PRODUCTION

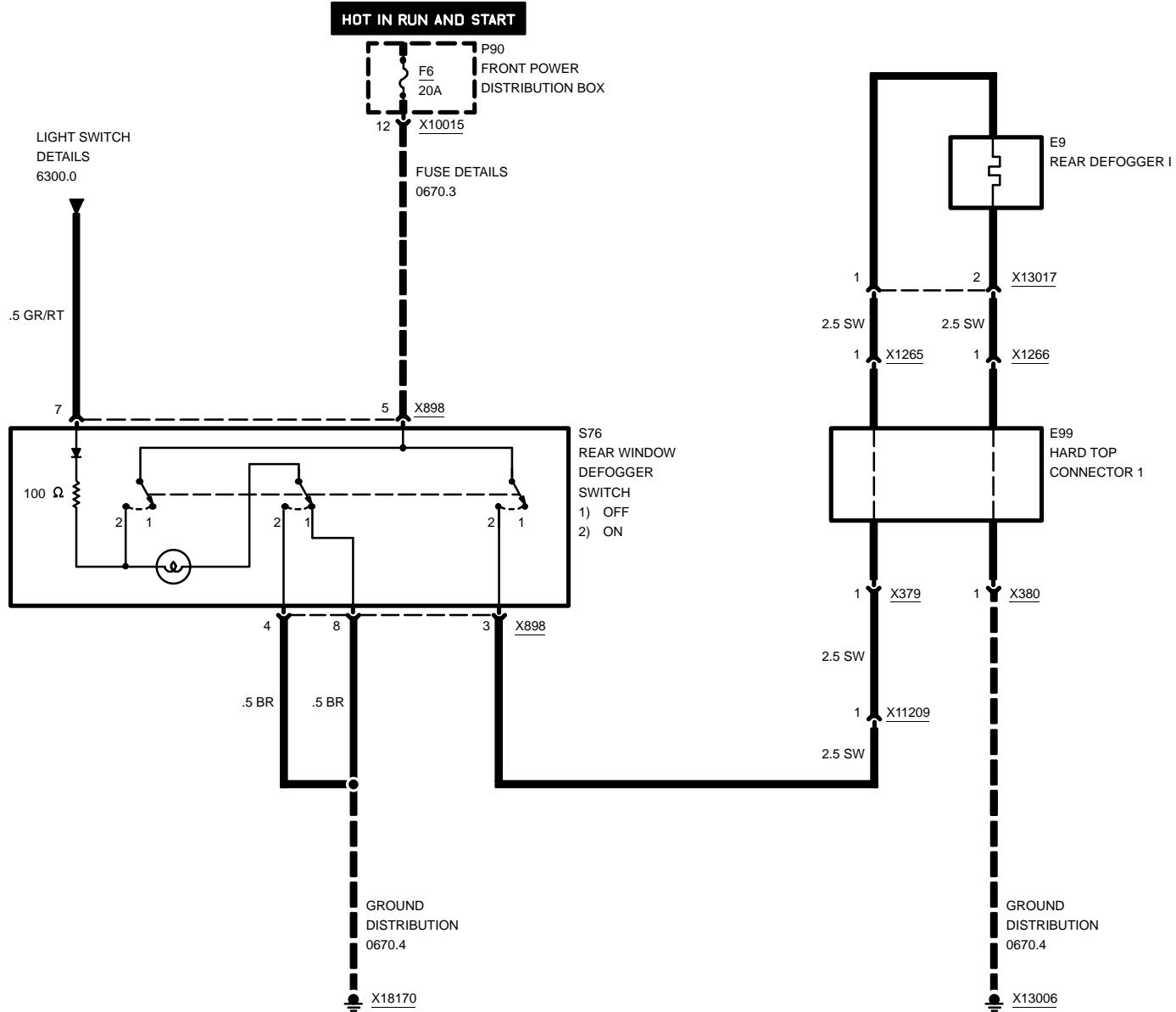

04/99

6424.0-00

1998



Z3

REAR WINDOW DEFOGGER

LATE PRODUCTION

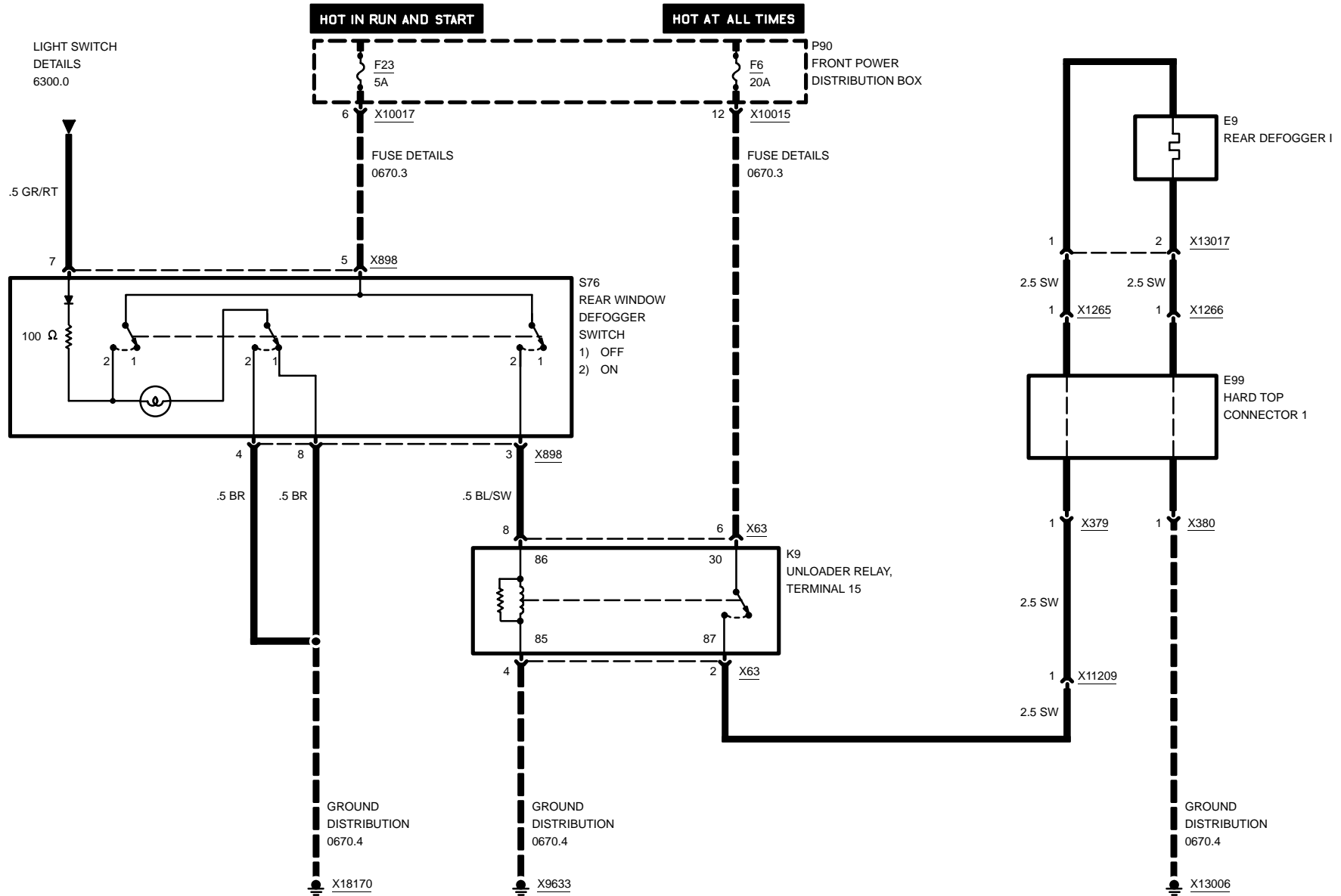

04/99

6424.0-01

1998

Z3 ROADSTER

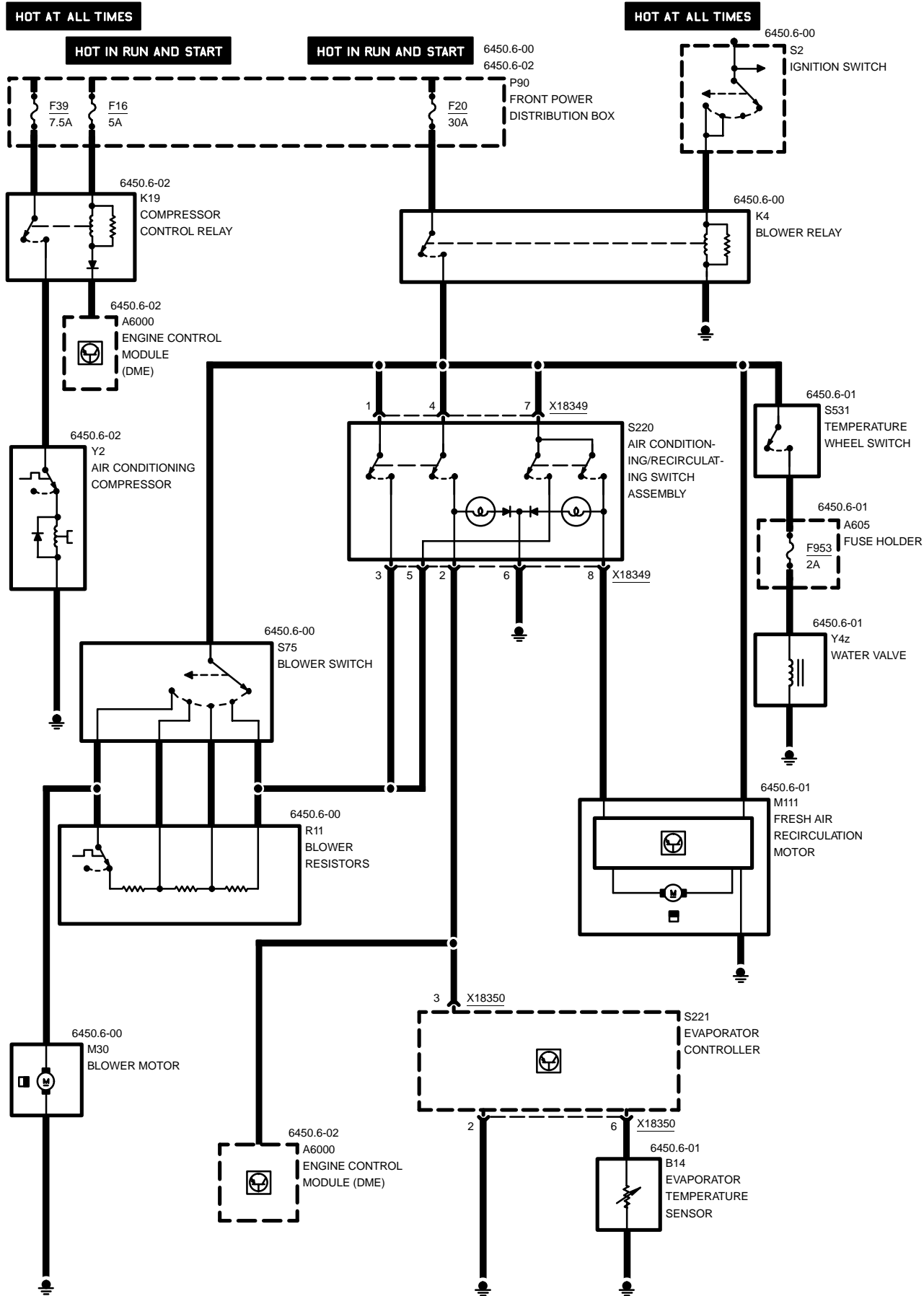

AUXILIARY FAN - 4-CYLINDER

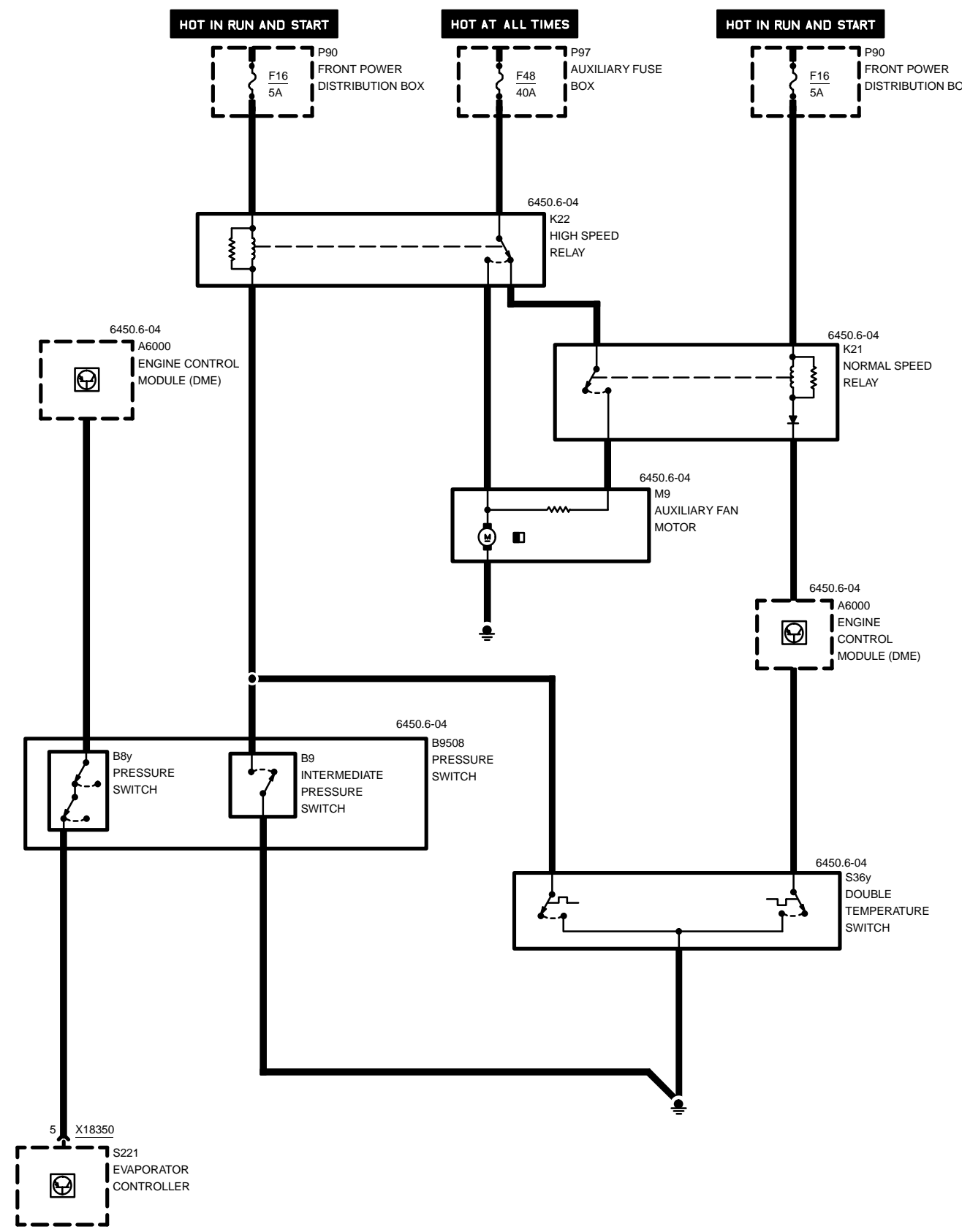

AUXILIARY FAN - 6-CYLINDER

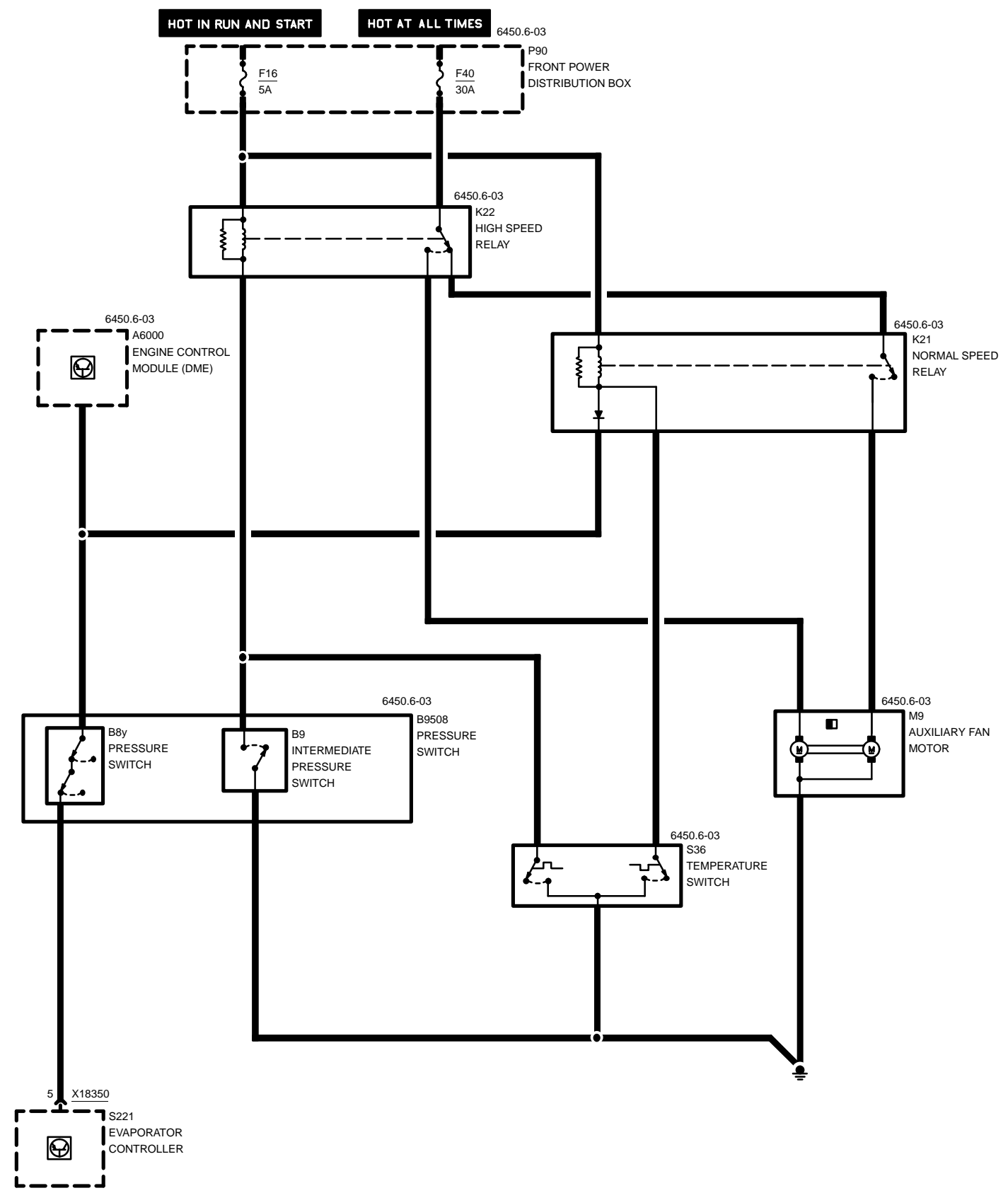

M ROADSTER

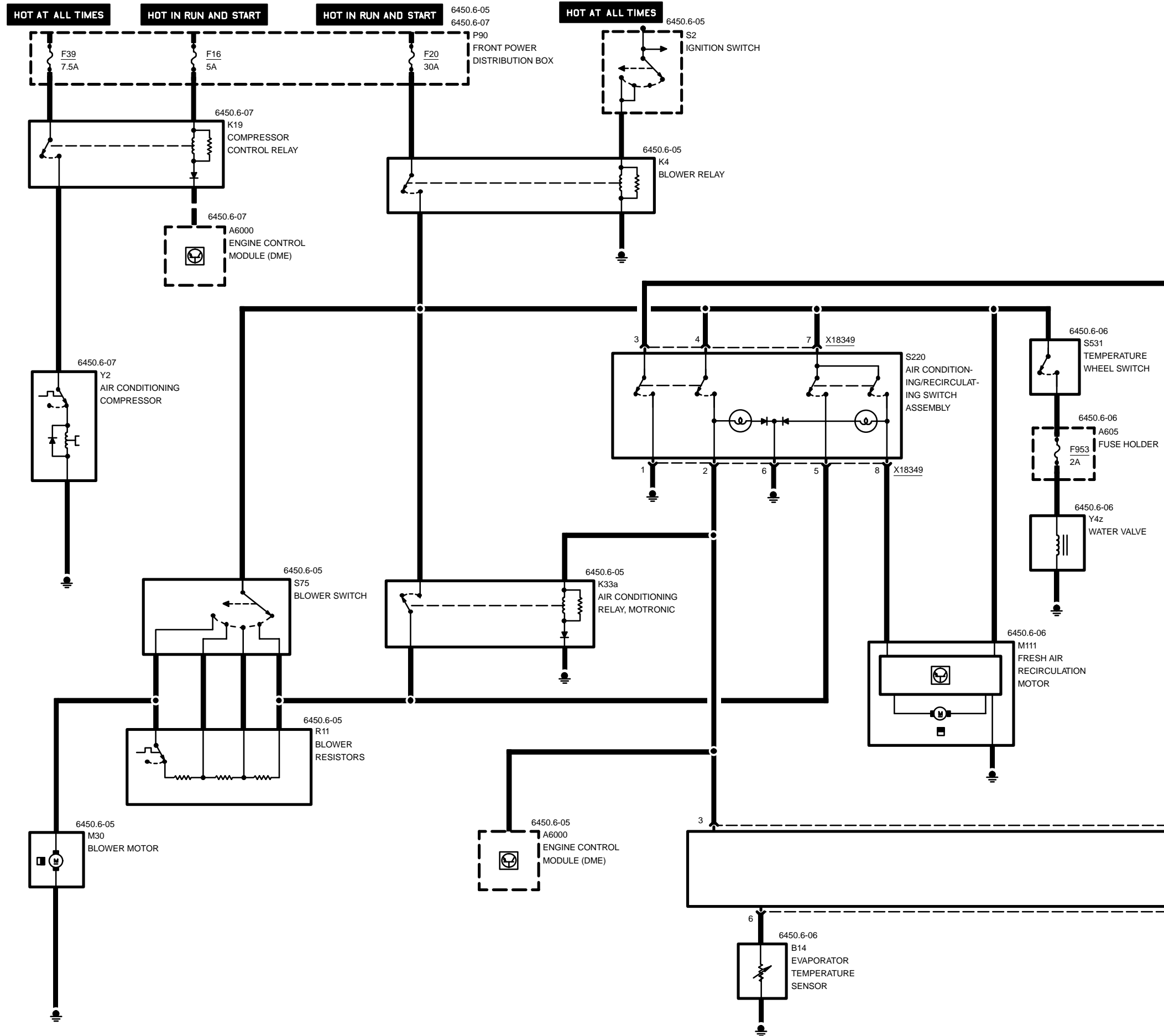

AUXILIARY FAN

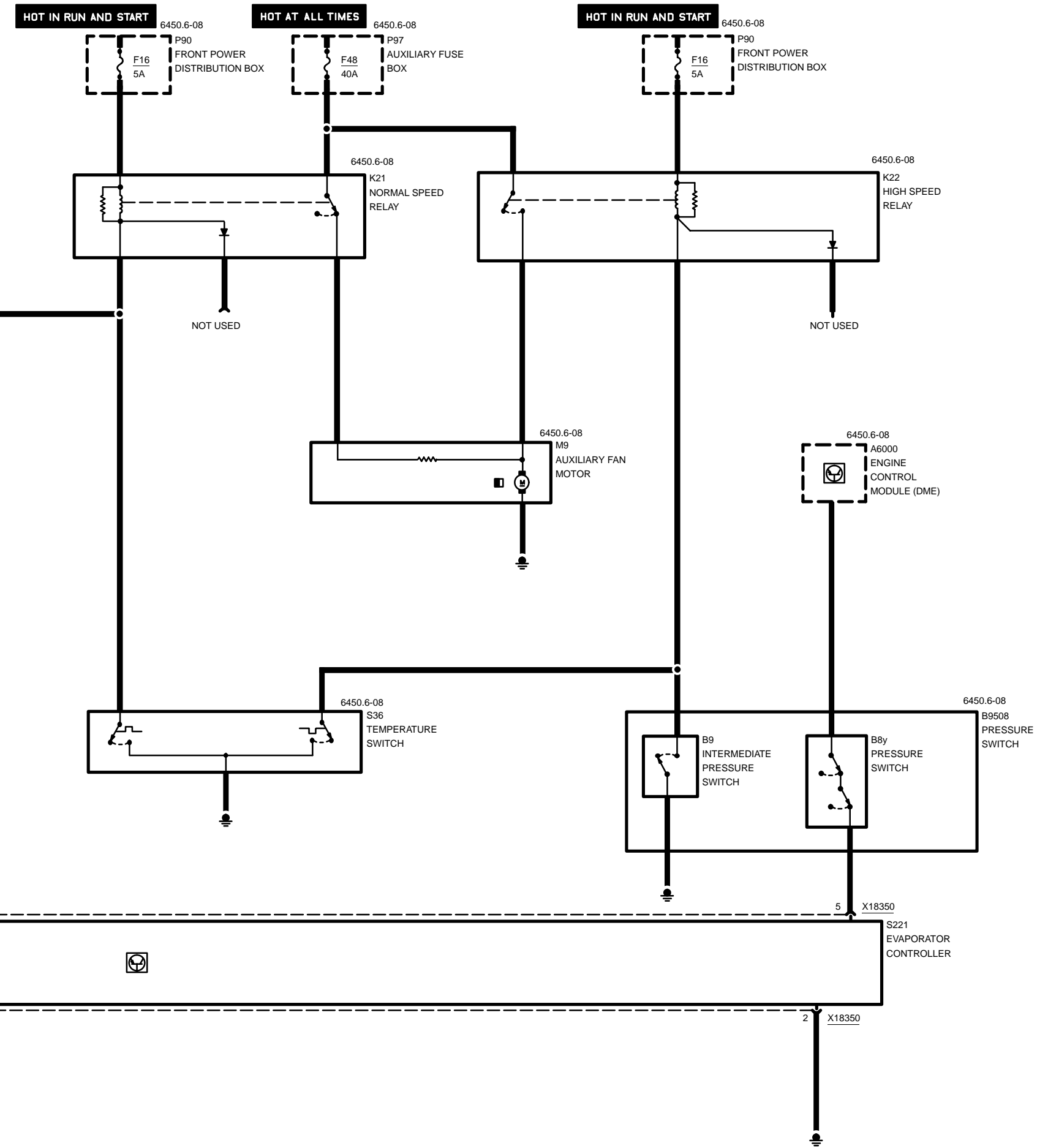

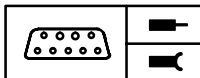

Z3

**Pin Assignments (Z3 Roadster)**

X18349	8 Pins, black
X18350	6 Pins, black

X18349

Pin	Type	Description/Function	Connection
1	E	Terminal 15	Heating blower relay
2	A	Activate compressor clutch	Engine control module (DME)
3	A	Blower level 1 (air conditioning)	Blower resistor
4	E	Terminal 15	Heating blower relay
5	A	Blower level 1 (air-recirculation)	Blower resistor
6	M	Ground for function lights	Ground point
7	E	Terminal 15	Heating blower relay
8	A	Activate fresh air-recirculation	Fresh air-recirculation motor

X18350

Pin	Type	Description/Function	Connection
1		Not used	
2	M	Ground	Ground point
3	E	Climate-ON-signal	Air conditioning/recirculated air operating unit
4		Not used	
5	A	Activate A/C compressor	Pressure switch
6	E	Evaporator temperature	Evaporator temperature sensor

E = Input, A = Output, M = Ground

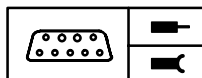

Z3

**Pin Assignments (M Roadster)**

X18349	8 Pins, black
X18350	6 Pins, black

X18349

Pin	Type	Description/Function	Connection
1	M	Ground	Ground point
2	A	A/C-ON-signal	Evaporator controller
3	A	A/C-ON-signal	Normal speed relay
4	E	Terminal 15	Heating blower relay
5	A	Blower level 1 (air-recirculation)	Blower resistor
6	M	Ground for function lights	Ground point
7	E	Terminal 15	Heating blower relay
8	A	Activate fresh air-recirculation	Fresh air-recirculation motor

X18350

Pin	Type	Description/Function	Connection
1		Not used	
2	M	Ground	Ground point
3	E	Climate-ON-signal	Air conditioning/recirculated air operating unit
4		Not used	
5	A	Activate A/C compressor	Pressure switch
6	E	Evaporator temperature	Evaporator temperature sensor

E = Input, A = Output, M = Ground

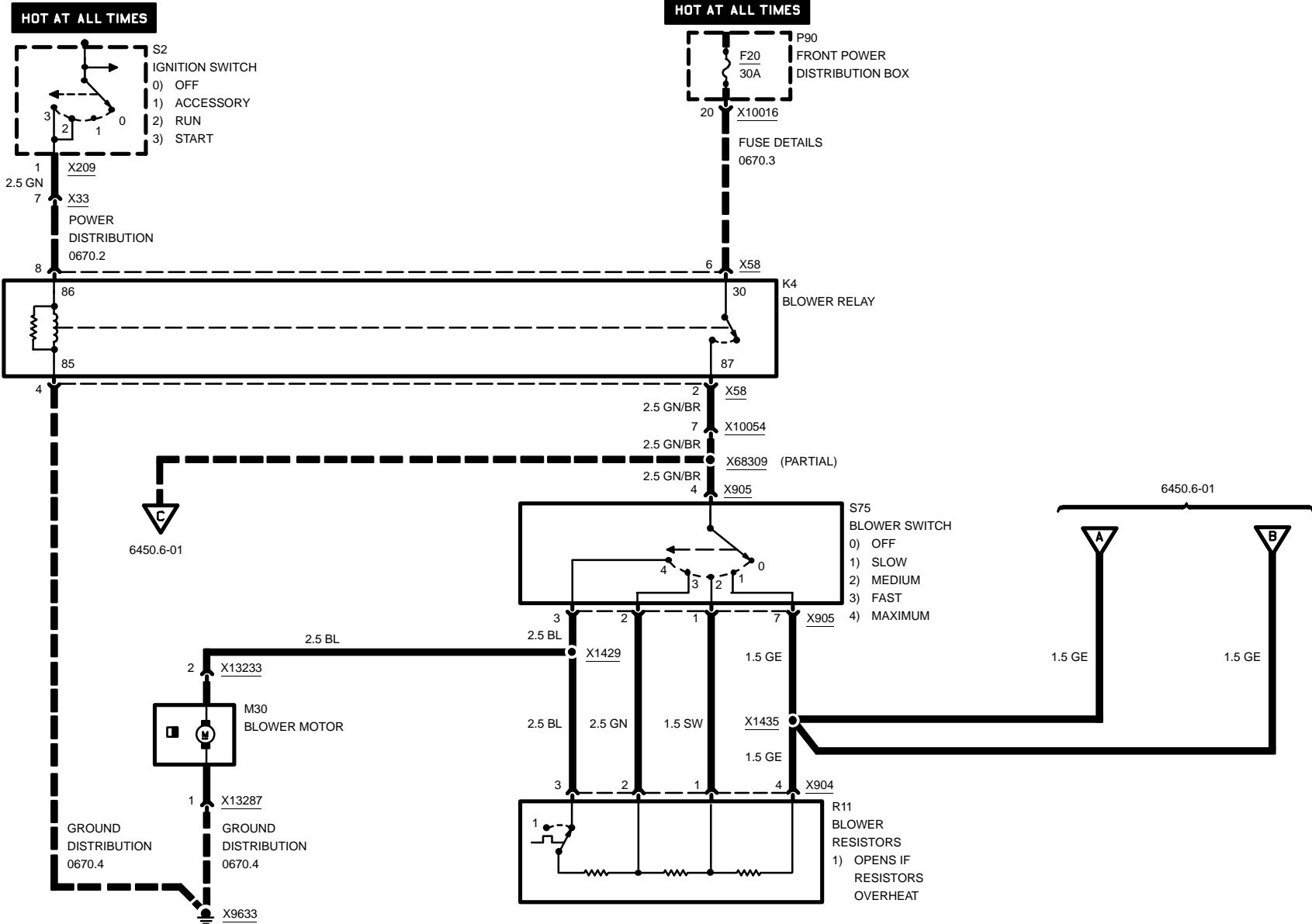

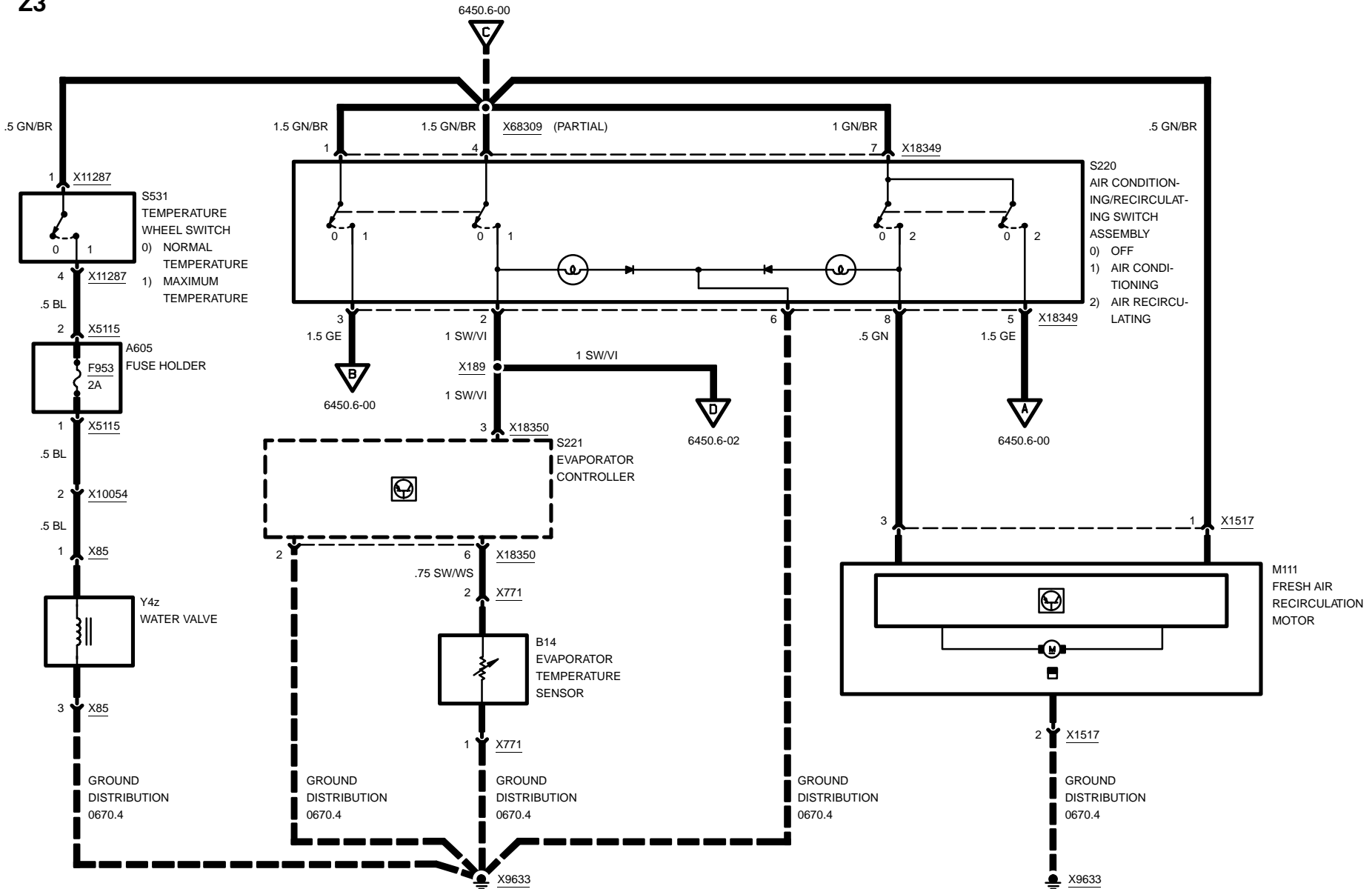

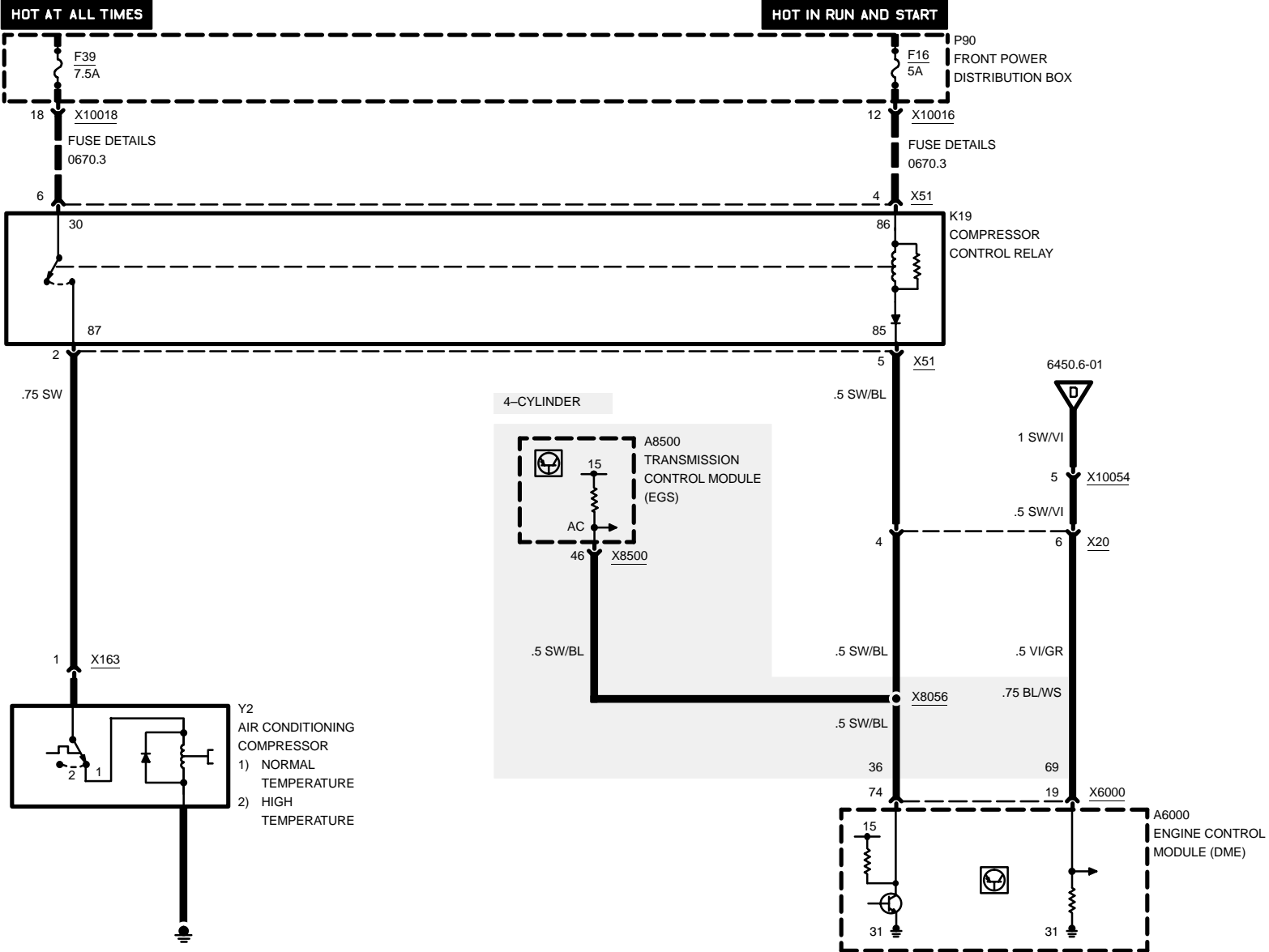

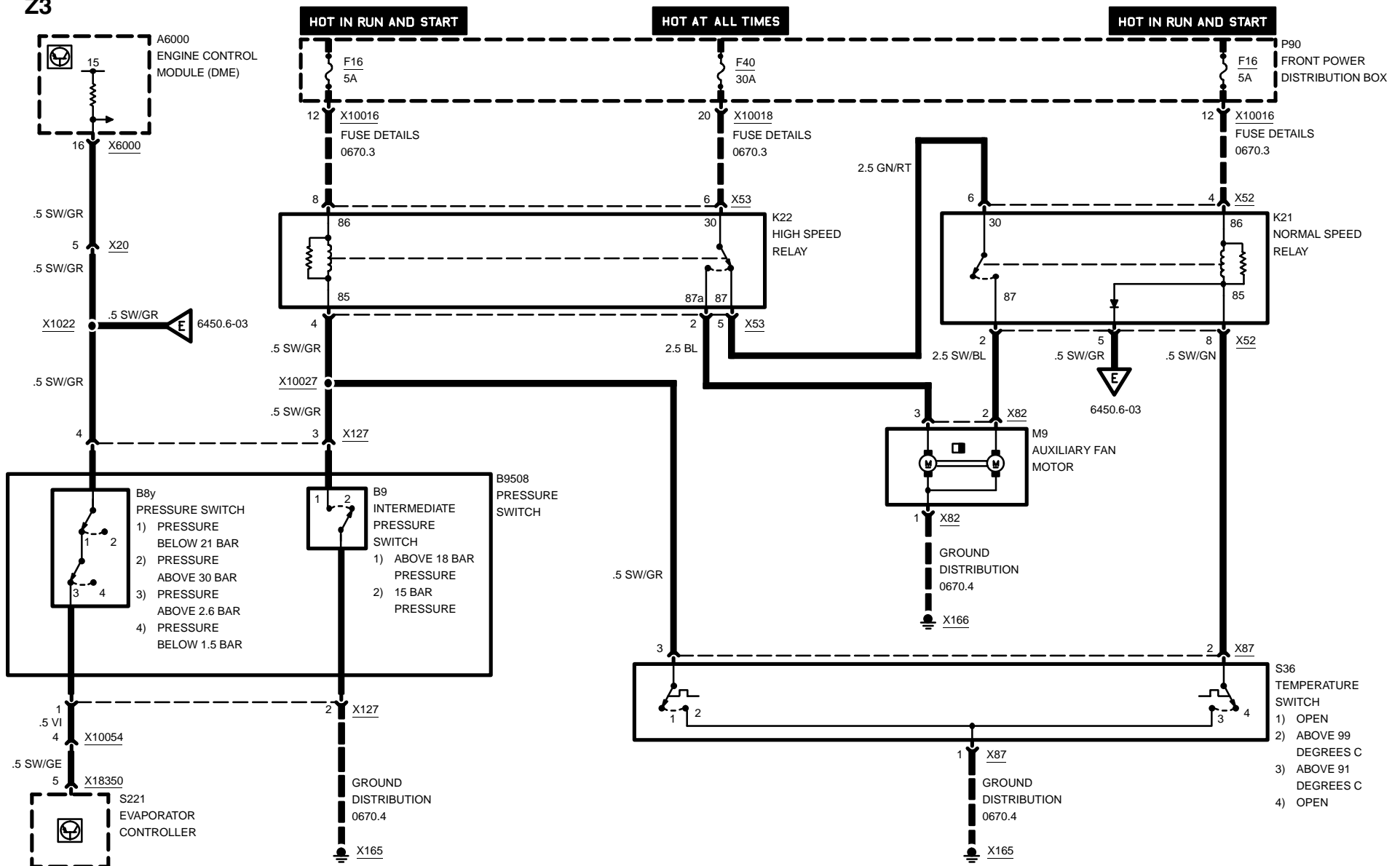

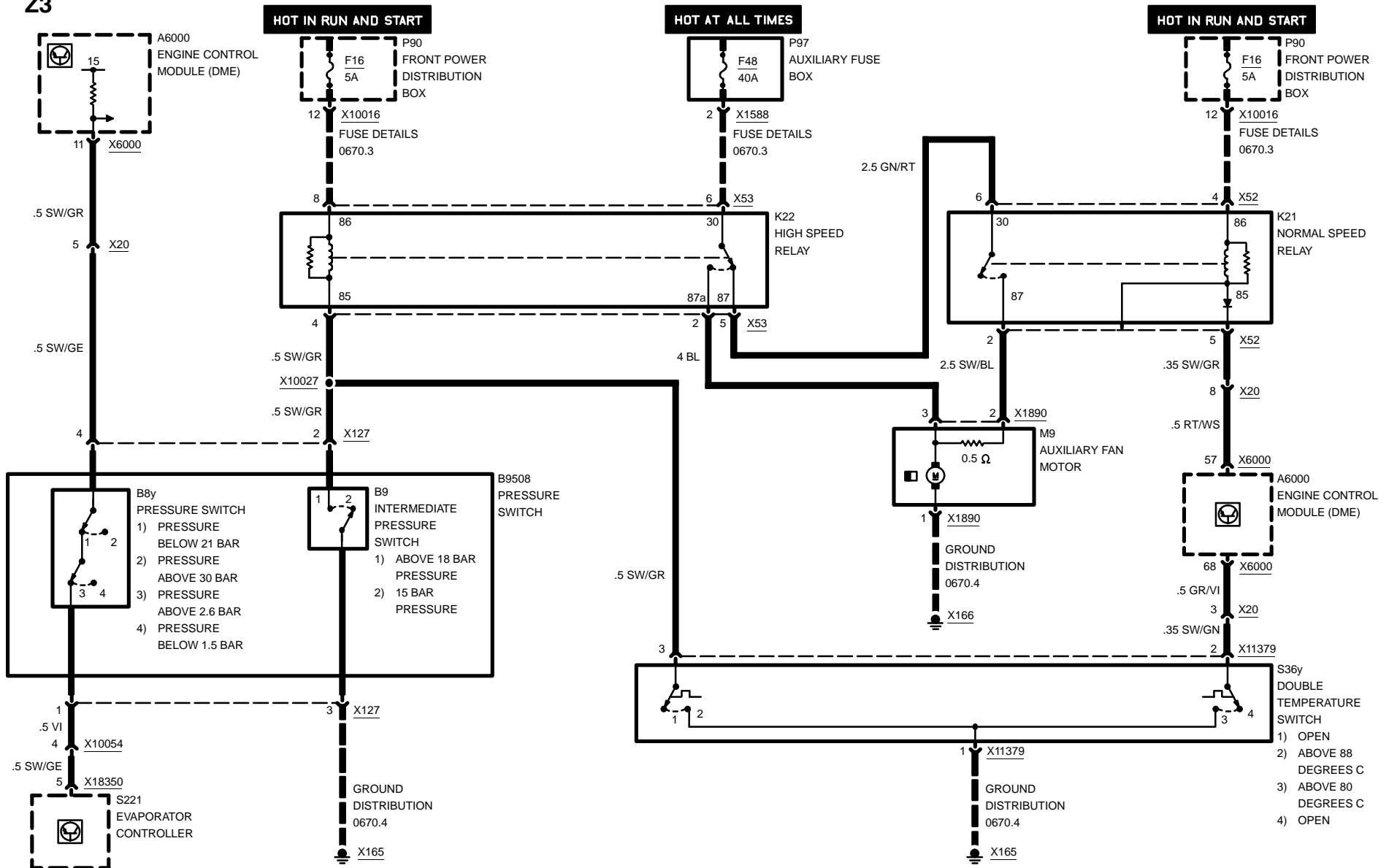



Z3

INTEGRATED HEATING- AND CLIMATE CONTROL POWER, AIR FLOW CONTROL

M ROADSTER

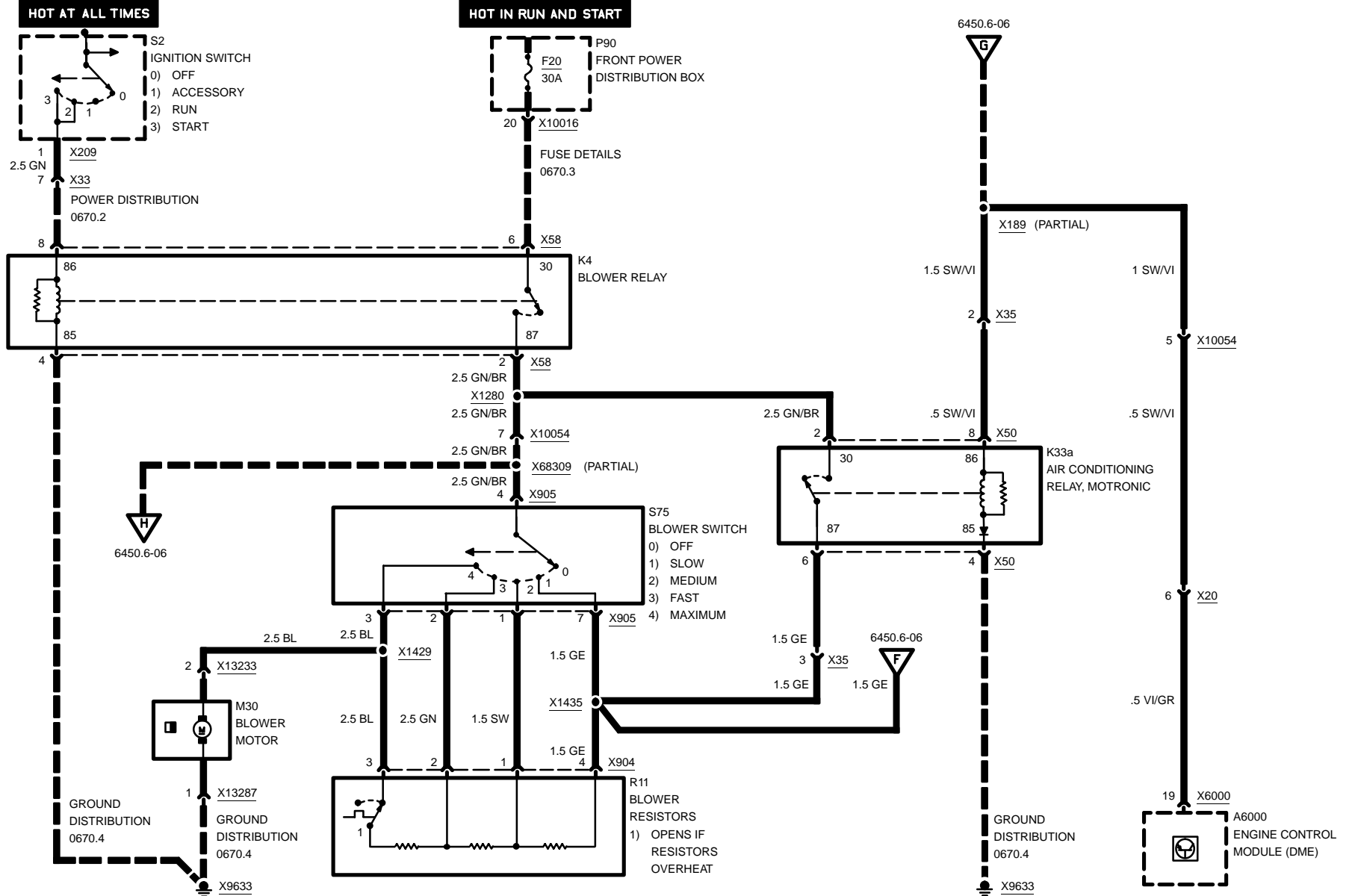

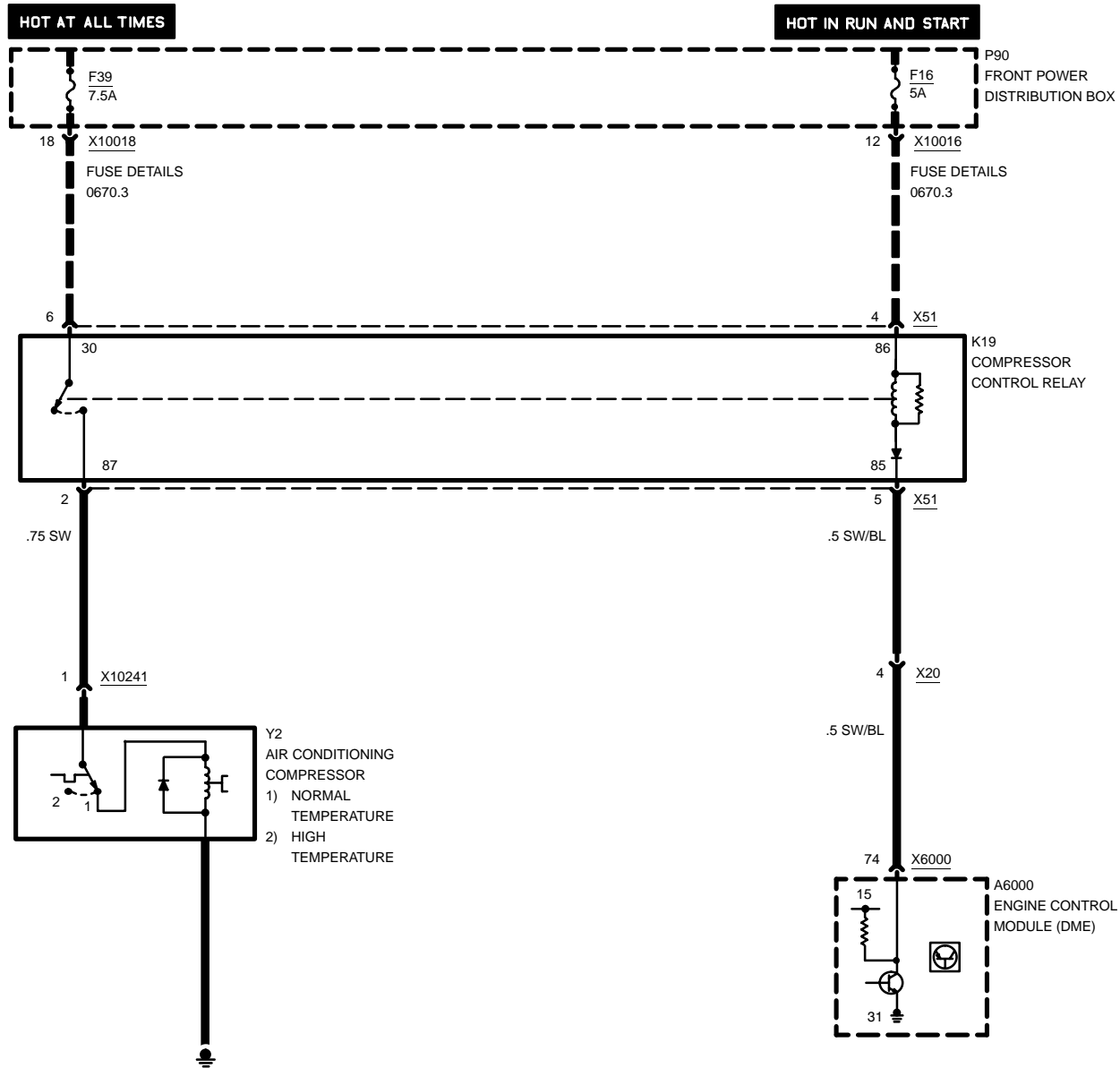

INTEGRATED HEATING- AND CLIMATE CONTROL

AUXILIARY FAN

M ROADSTER

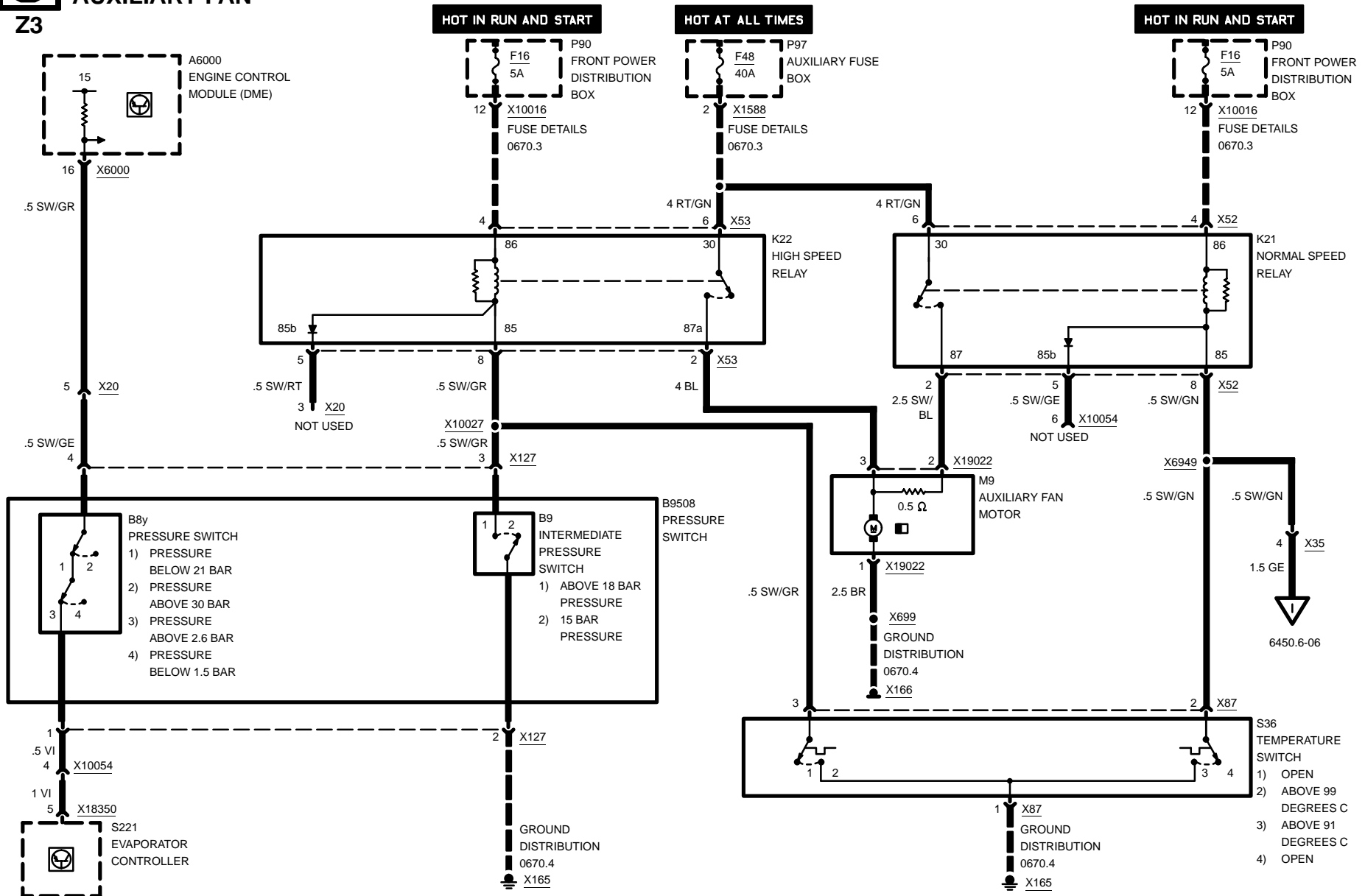



6510.1 RADIO/HIFI

Z3

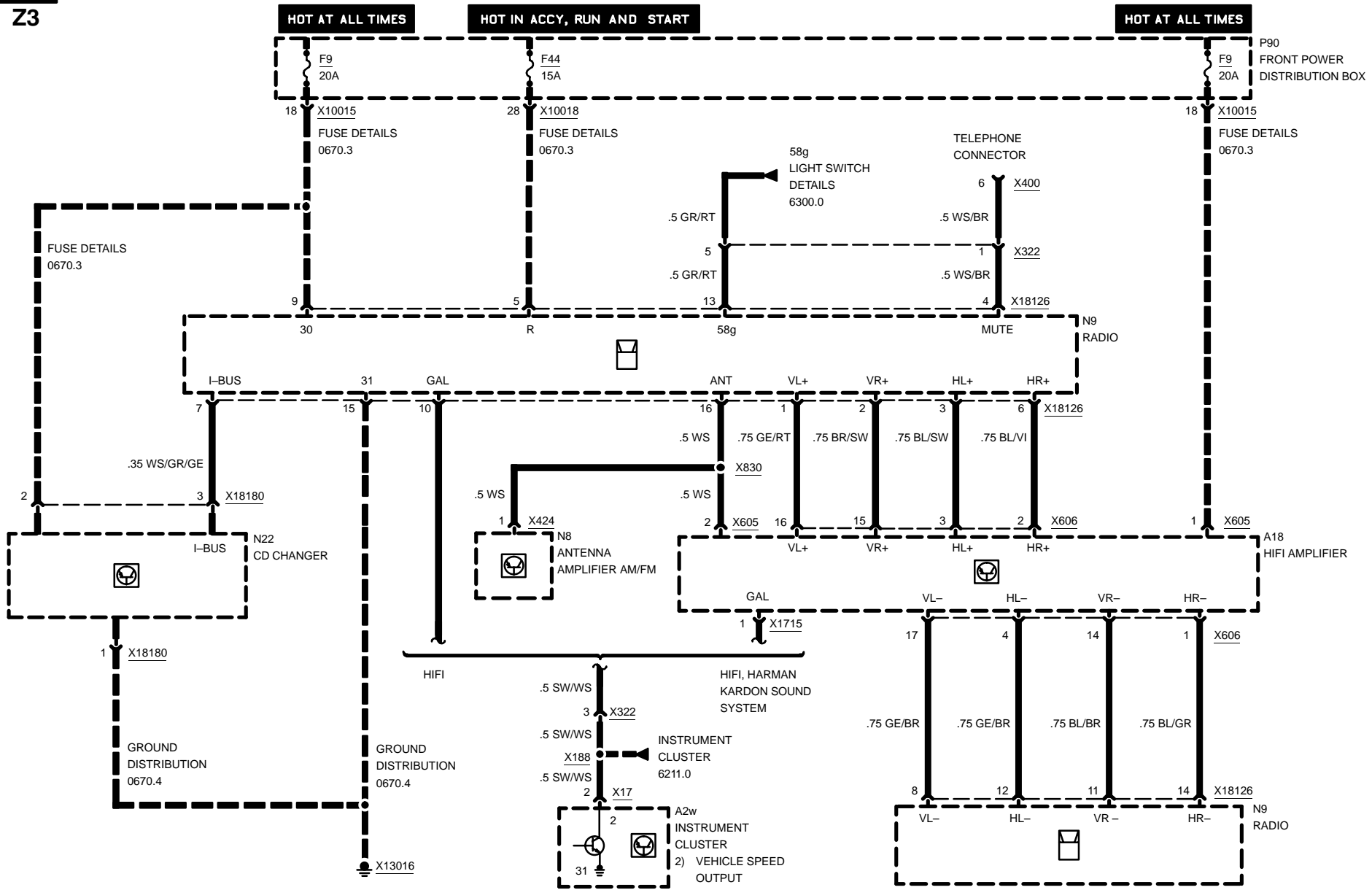

04/99

6510.1-00

1998



RADIO/HIFI

Z3

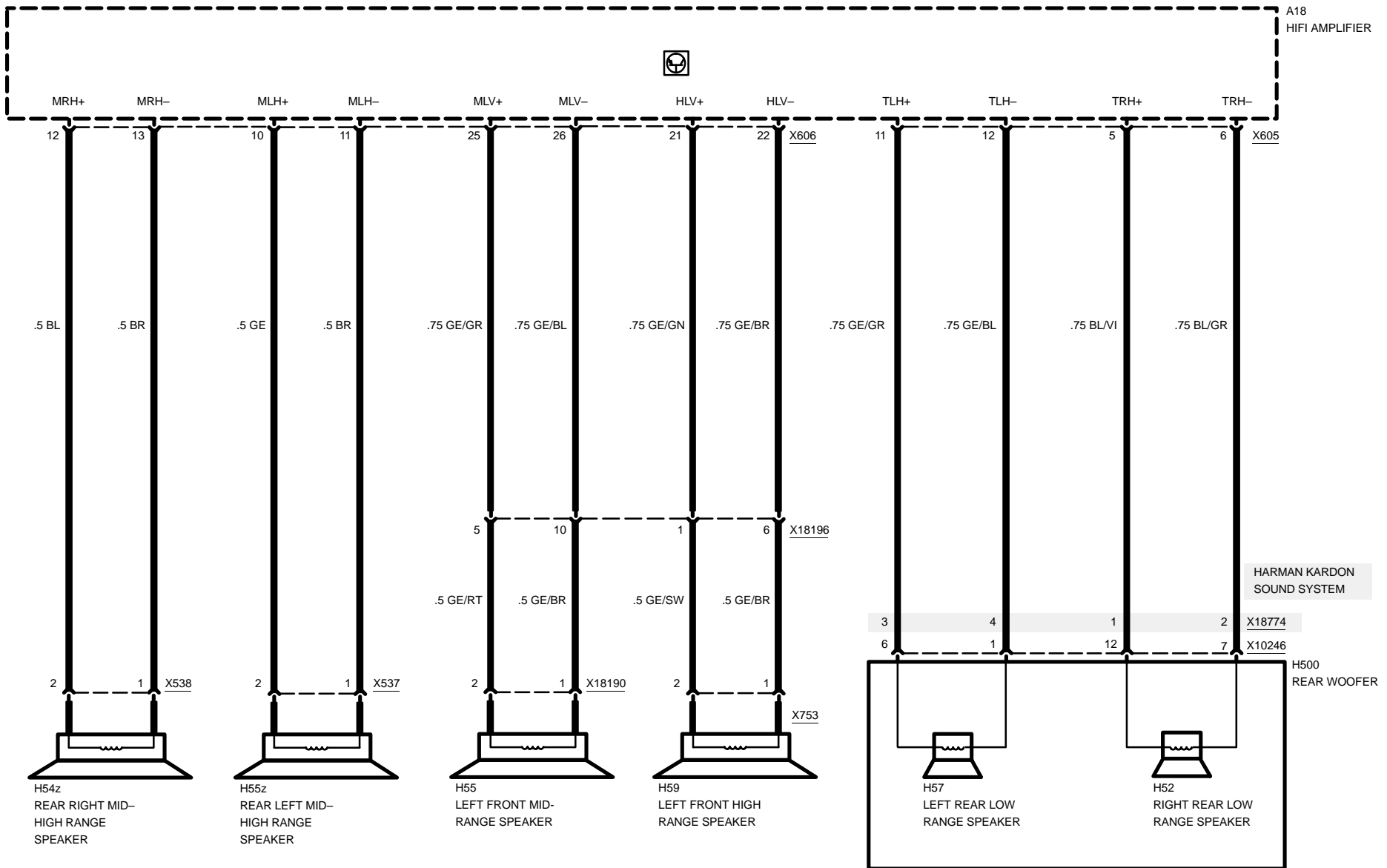

04/99

6510.1-01

1998



RADIO/HIFI

Z3

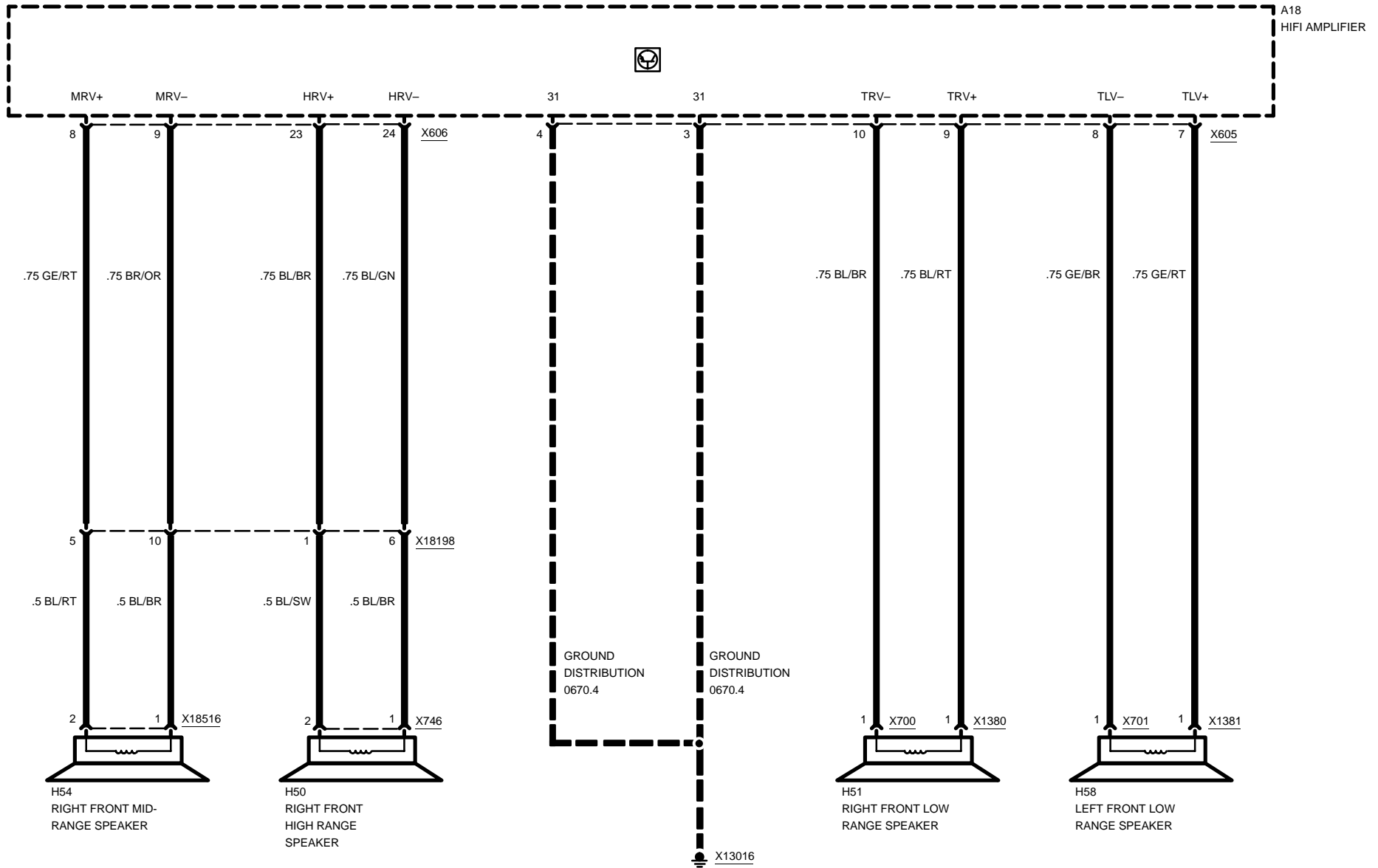



RADIO/HIFI

Z3

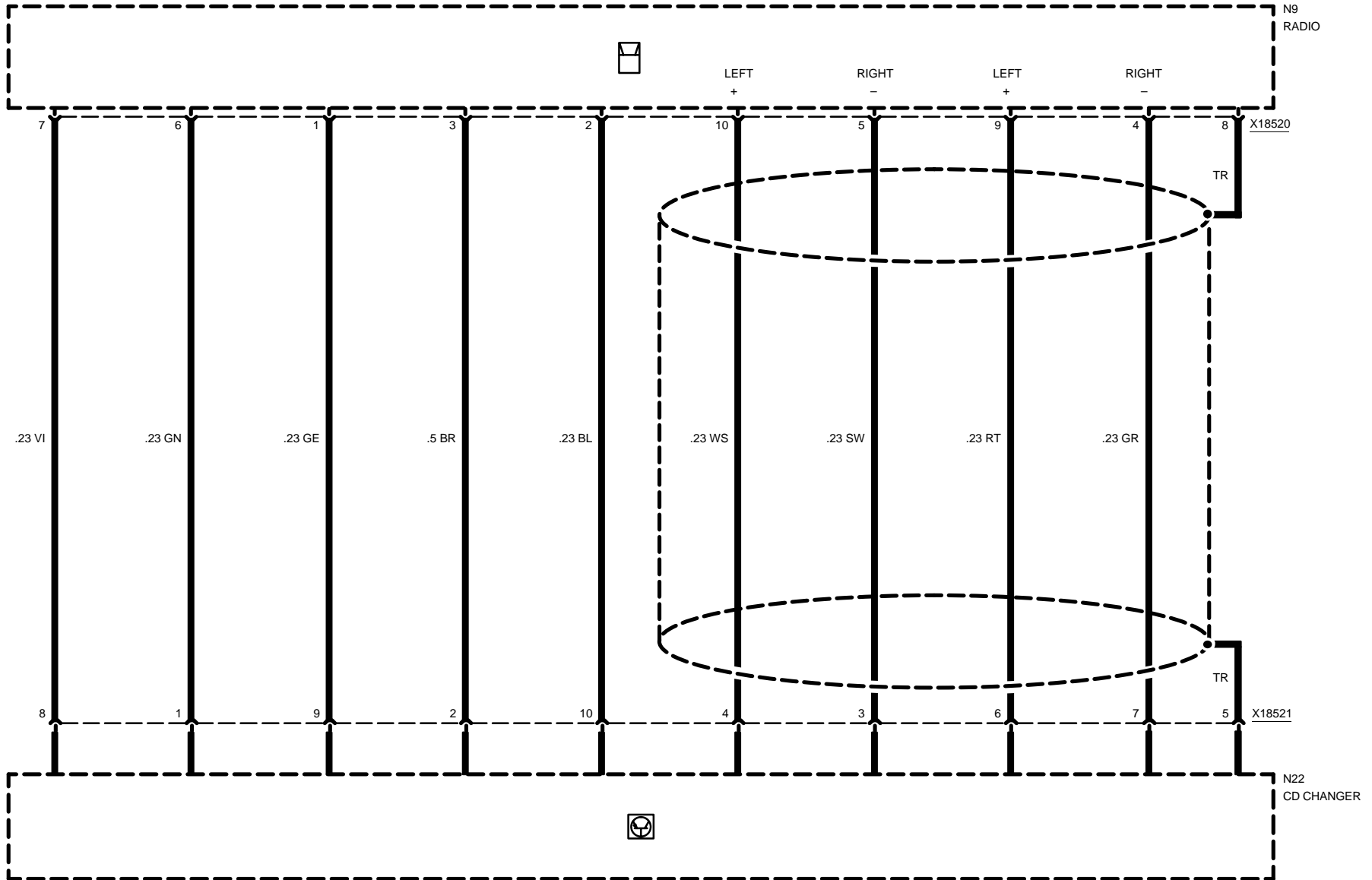



6561.0 CELLULAR TELEPHONE (PROVISIONS) PROVISIONS

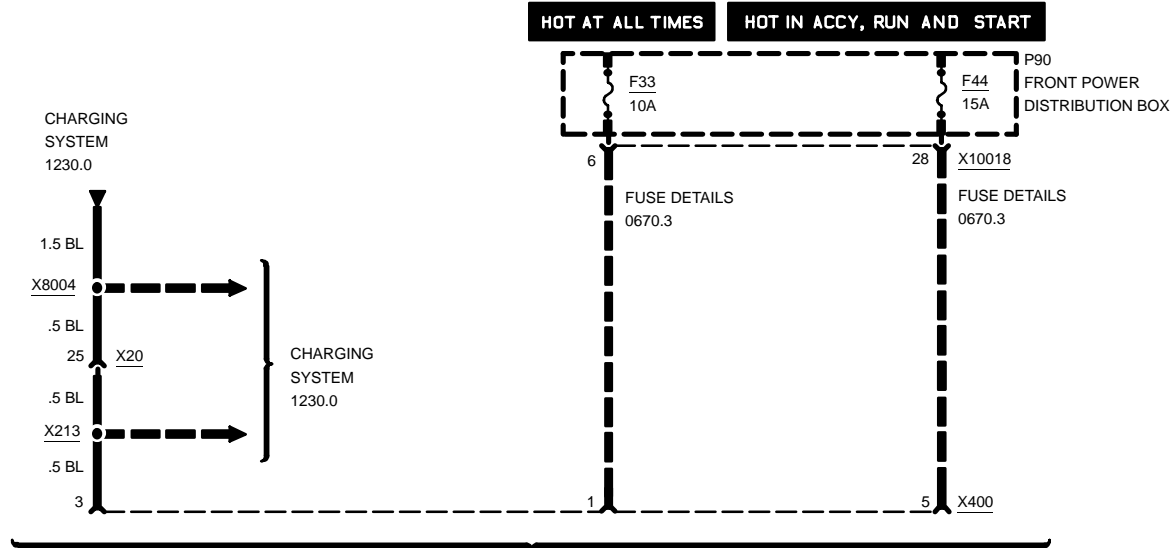

TELEPHONE CONNECTOR

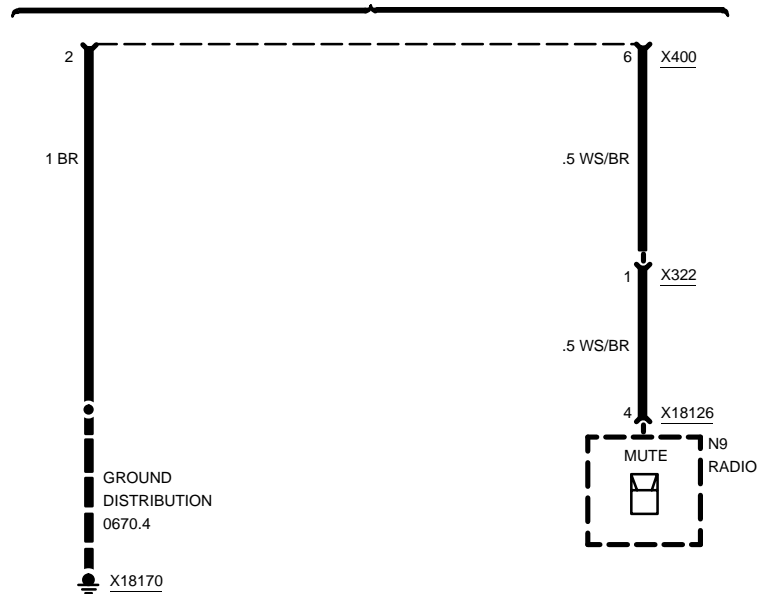

6571.0 CRUISE CONTROL (TEMPOMAT)

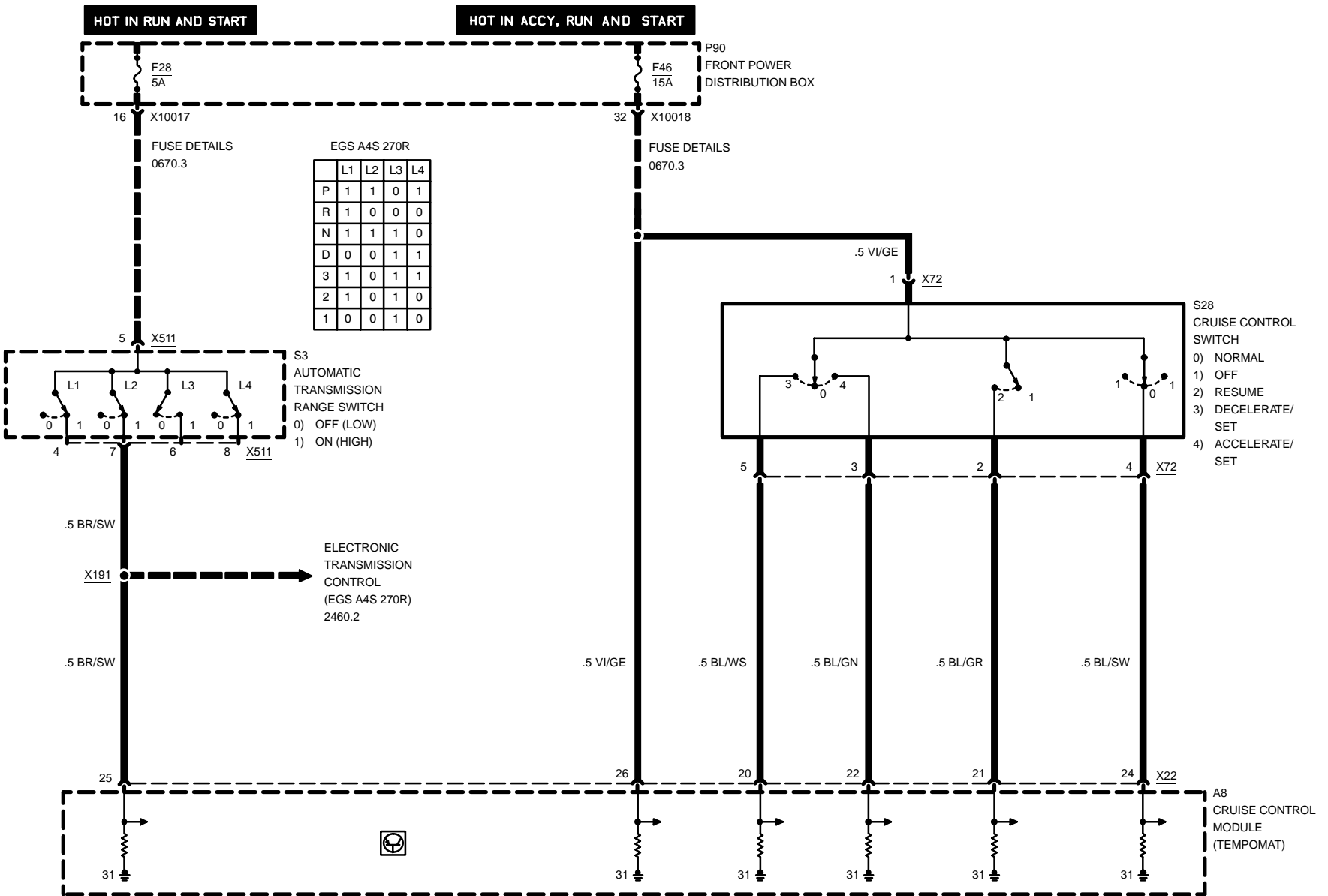



CRUISE CONTROL (TEMPOMAT)

Z3

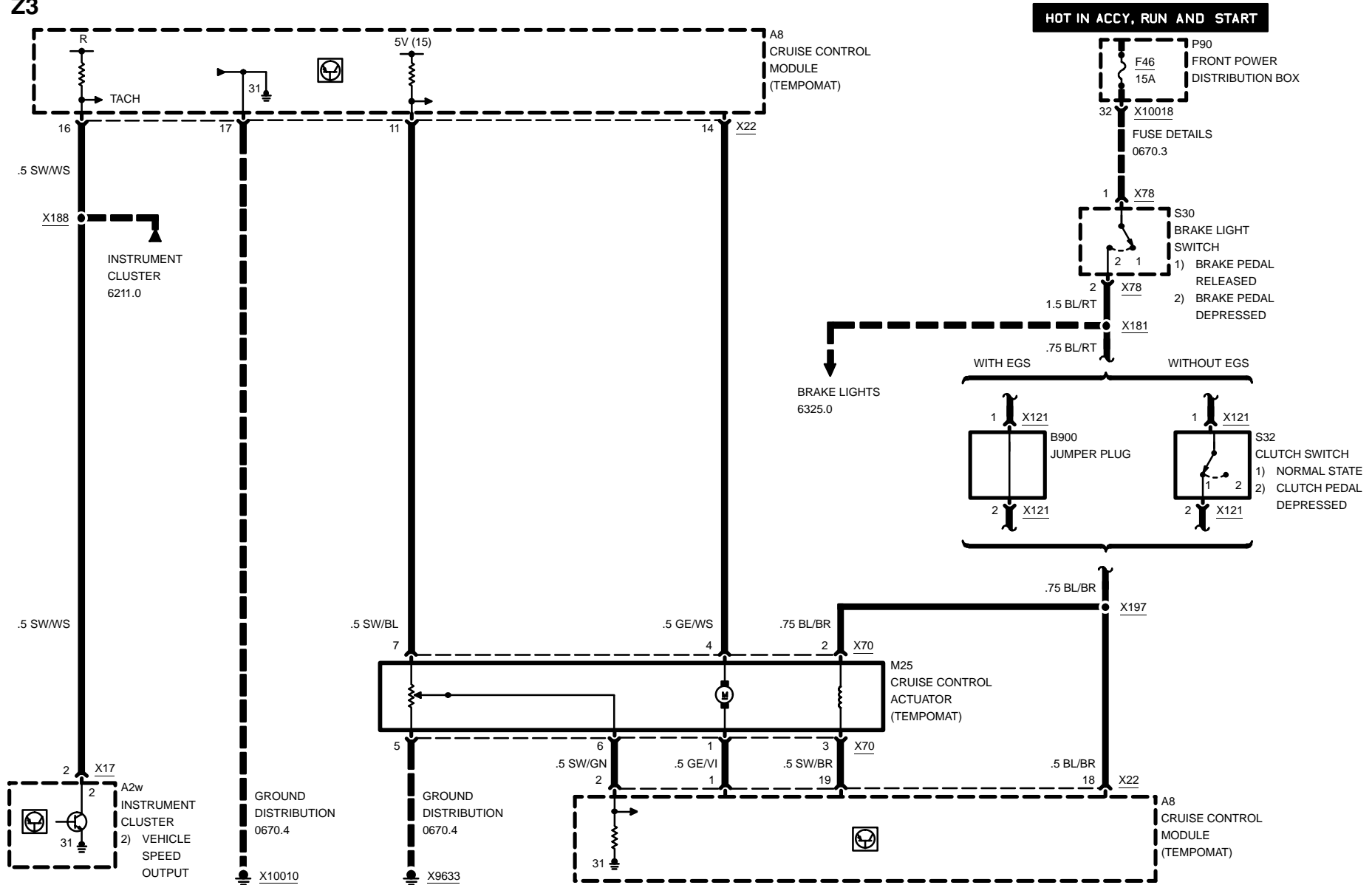

04/99

6571.0-01

1998

6575.2 ANTI-THEFT SYSTEM (ALPINE)

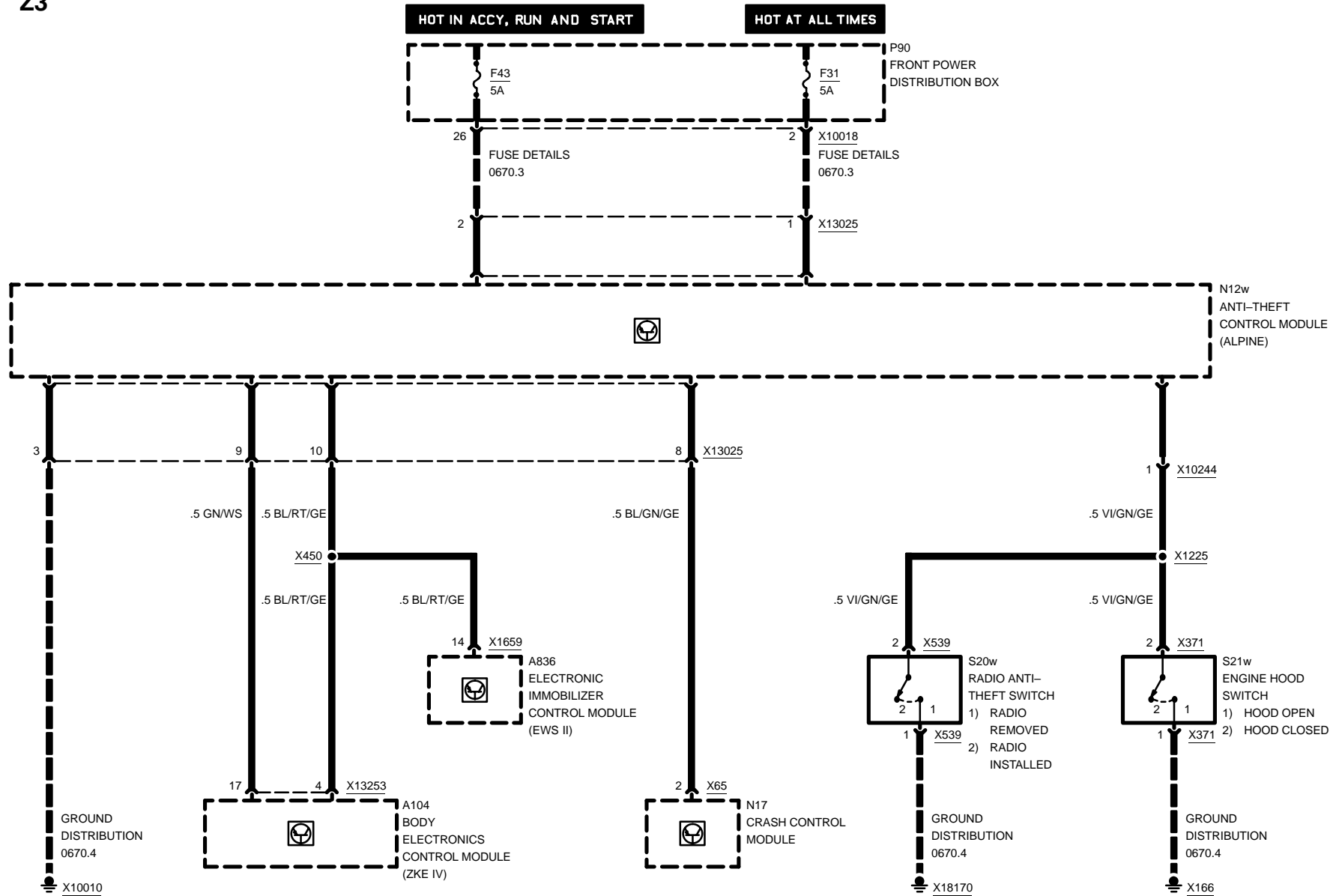

ANTI-THEFT SYSTEM (ALPINE)

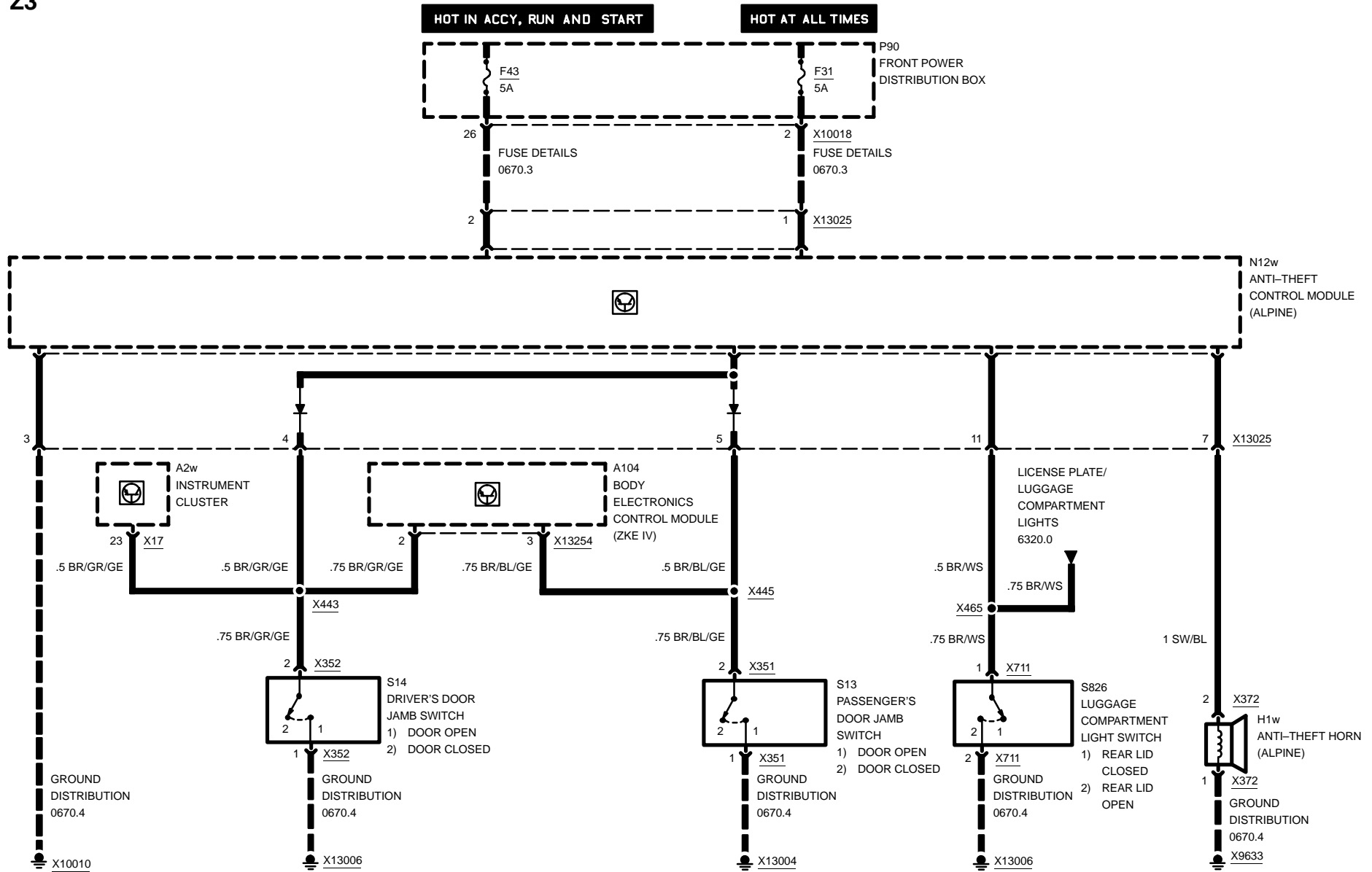



Z3

6581.3 BOARD COMPUTER (BC - LOW)

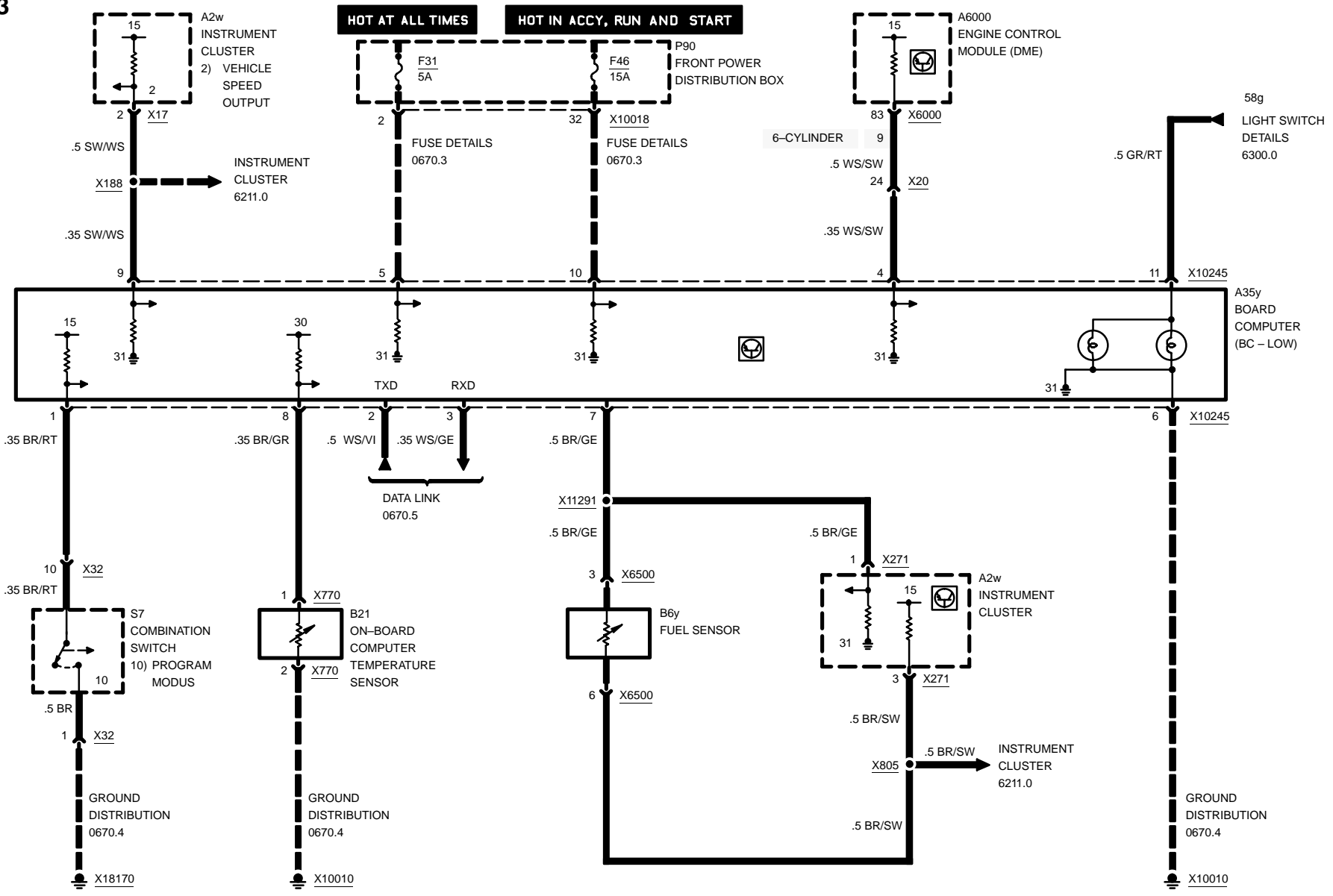

04/99

6581.3-00

1998



Z3

7000.0 COMPONENT LOCATION CHART

COMP.	DESCRIPTION	LOCATION	7100.0	8500.0
A2w ..	INSTRUMENT CLUSTER	LH side of dash	20-2	
A7	SLIP CONTROL MODULE (ABS)	behind glove box	00-1	
A8	CRUISE CONTROL MODULE (TEMPOMAT)	behind glove box	00-2	
A12 ..	SUPPLEMENTAL RESTRAINT SYSTEM CONTROL MODULE	below center console	22-2	
A18 ..	HIFI AMPLIFIER	in RH side of luggage compartment	27-3	
A35y .	BOARD COMPUTER (BC – LOW)	center console	01-3	
A51 ..	WIPER/WASHER MODULE	behind glove box	00-2	
A52 ..	SLIP CONTROL MODULE (ABS/ASC)	behind glove box (4–cylinder)	00-1	
A52 ..	SLIP CONTROL MODULE (ABS/ASC)	behind glove box (6–cylinder)	00-3	
A64 ..	WIPER/WASHER MODULE (LOW II)	behind glove box	00-2	
A104 .	BODY ELECTRONICS CONTROL MODULE (ZKE IV)	behind glove box	00-2	
A110 ..	DIGITAL CLOCK	center console		
A113 ..	SEAT OCCUPANCY DETECTOR	under RH front seat	24-1	
A113 ..	SEAT OCCUPANCY DETECTOR	under RH front seat (WITH SPORT SEAT)	41-2	
A605 .	FUSE HOLDER	center console (radio and console removed)	38-1	
A835 .	TRANSMITTER MODULE (EWS II)	near steering column	01-2	
A836 .	ELECTRONIC IMMOBILIZER CONTROL MODULE (EWS II)	behind glove box	00-1	
A6000	ENGINE CONTROL MODULE (DME)	rear RH side of engine compartment in E–Box	01-1	
A8500	TRANSMISSION CONTROL MODULE (EGS)	rear RH side of engine compartment in E–Box	01-1	

04/99

7000.0-0

1998



COMPONENT LOCATION CHART

Z3

COMP.	DESCRIPTION	LOCATION	7100.0	8500.0
B1	RIGHT FRONT SPEED SENSOR – ABS	on RH front wheel, above brake caliper		
B2	LEFT FRONT SPEED SENSOR – ABS	on LH front wheel, above brake caliper	12-3	
B3	RIGHT REAR SPEED SENSOR – ABS	on RH rear wheel, above brake caliper		
B4	LEFT REAR SPEED SENSOR – ABS	on LH rear wheel, above brake caliper		
B6y	FUEL SENSOR	in fuel tank		
B8y	PRESSURE SWITCH	front RH side of engine compartment		
B9	INTERMEDIATE PRESSURE SWITCH	front RH side of engine compartment		
B10	VEHICLE SPEED SENSOR	on differential	15-2	
B14	EVAPORATOR TEMPERATURE SENSOR	RH side of LH footwell	21-2	
B16	LEFT FRONT BRAKE PAD SENSOR	on LH front wheel, above brake caliper	12-3	
B17	RIGHT REAR BRAKE PAD SENSOR	behind RH rear wheel		
B18	BRAKE FLUID LEVEL SWITCH	rear LH side of engine compartment	09-1	
B21	ON-BOARD COMPUTER TEMPERATURE SENSOR	on front LH wheel well (4-cylinder)	12-1	
B21	ON-BOARD COMPUTER TEMPERATURE SENSOR	in RH front bumper (6-cylinder)	35-2	
B59	OIL TEMPERATURE GAUGE	center console		
B65	FUEL TANK PRESSURE SENSOR	top of fuel tank	40-2	
B78	DRIVER'S SIDE IMPACT SENSOR	under LH front seat	39-3	
B79	PASSENGER'S SIDE IMPACT SENSOR	under RH front seat	39-1	
B900	JUMPER PLUG	LH footwell		
B6203	CRANKSHAFT POSITION/RPM SENSOR	rear LH side of engine compartment	32-3	

04/99

7000.0-1

1998



COMPONENT LOCATION CHART

Z3

COMP.	DESCRIPTION	LOCATION	7100.0	8500.0
B6204	CAMSHAFT POSITION SENSOR (CYLINDER IDENTIFICATION)	front of engine	31-3	
B6205	INTAKE AIR TEMPERATURE SENSOR ..	front LH side of engine compartment (4-cylinder)	11-2	
B6205	INTAKE AIR TEMPERATURE SENSOR ..	front LH side of engine compartment (6-cylinder)	34-1	
B6207	HOT FILM AIR MASS METER	LH side of engine compartment	33-3	
B6209	HALL EFFECT CAMSHAFT SENSOR	front of engine		
B6210y	OXYGEN SENSOR (IN FRONT OF CATALYTIC CONVERTER)	under center of car	35-1	
B6217	HOT FILM AIR MASS METER	front LH side of engine compartment	11-3	
B6220y	OXYGEN SENSOR (BEHIND CATALYTIC CONVERTER)	under center of car	35-1	
B6231	OIL PRESSURE SWITCH	lower LH side of engine	32-2	
B6232	ENGINE COOLANT TEMPERATURE SENSOR	front of engine	10-2	
B6238	OIL TEMPERATURE SENSOR	RH side of oil filter	32-2	
B6240	KNOCK SENSOR	top front of engine (4-cylinder)	10-2	
B6240	KNOCK SENSOR	top front of engine (6-cylinder)	33-2	
B6247	CHARCOAL FILTER SHUT-OFF VALVE ..	under LH rear of car	36-1	
B6256	DUAL TEMPERATURE SENSOR (COOLANT TEMPERATURE)	rear of engine compartment	32-1	
B9508	PRESSURE SWITCH	front RH side of engine compartment	30-2	
B62001	OXYGEN SENSOR (IN FRONT OF CATALYTIC CONVERTER)	under center of car	14-3	



COMPONENT LOCATION CHART

Z3

COMP.	DESCRIPTION	LOCATION	7100.0	8500.0
B62002	OXYGEN SENSOR (BEHIND CATALYTIC CONVERTER)	under center of car		
B62101	OXYGEN SENSOR I (IN FRONT OF CATALYTIC CONVERTER)	on catalytic converter		
B62102	OXYGEN SENSOR I (BEHIND CATALYTIC CONVERTER)	on catalytic converter		
B62201	OXYGEN SENSOR II (IN FRONT OF CATALYTIC CONVERTER)	on catalytic converter		
B62202	OXYGEN SENSOR II (BEHIND CATALYTIC CONVERTER)	on catalytic converter		
C101	CONTACT RING	top of steering column	38-3	
D100	DATA LINK CONNECTOR	rear RH side of engine compartment	31-1	
D110	OBD II CONNECTOR	center console right	28-3	
E7	LEFT HEADLIGHT	front LH side of engine compartment		
E8	RIGHT HEADLIGHT	front RH side of engine compartment		
E9	REAR DEFOGGER I	hard top		
E11	LEFT HIGH BEAM LIGHT	near front LH headlight	29-1	
E12	RIGHT HIGH BEAM LIGHT	near front RH headlight		
E13	LEFT LOW BEAM LIGHT	near front LH headlight	29-1	
E14	RIGHT LOW BEAM LIGHT	near front RH headlight	29-3	
E15	LEFT PARK LIGHT	near front LH headlight		
E16	LEFT REAR LIGHT ASSEMBLY	LH side of body rear end		
E17	RIGHT REAR LIGHT ASSEMBLY	RH side of body rear end	03-1	
E19	RIGHT PARK LIGHT	near front RH headlight		

04/99

7000.0-3

1998



COMPONENT LOCATION CHART

Z3

COMP.	DESCRIPTION	LOCATION	7100.0	8500.0
E21	LEFT FRONT MARKER LIGHT	front of vehicle		
E22	RIGHT FRONT MARKER LIGHT	front of vehicle		
E25	FRONT ASHTRAY LIGHT	center console		
E26	LEFT FOG LIGHT	under LH front bumper		
E27	RIGHT FOG LIGHT	under RH front bumper	13-2	
E28	FRONT CIGAR LIGHTER	center console		
E28a	CIGAR LIGHTER CONNECTION	TIRE INFLATION SYSTEM		
E29	FRONT CIGAR LIGHTER LIGHT	center console	22-3	
E32	LUGGAGE COMPARTMENT LIGHT	in luggage compartment		
E43	LEFT LICENSE PLATE LIGHT	underside of luggage compartment lid, near license plate		
E44	RIGHT LICENSE PLATE LIGHT	underside of luggage compartment lid, near license plate		
E51	LEFT WASHER JET HEATER	on underside of engine hood	16-2	
E52	RIGHT WASHER JET HEATER	on underside of engine hood	16-2	
E56	DRIVER'S SEATBACK HEATER	in top of LH backrest		
E57	DRIVER'S SEAT HEATER	under LH front seat		
E58	PASSENGER'S SEAT HEATER	underside of RH front seat		
E59	PASSENGER'S SEATBACK HEATER	in top of RH backrest		
E82	TRANSMISSION POSITION INDICATOR LIGHT	center console	22-1	
E96	GEAR SHIFT LEVER INDICATOR	center console		
E99	HARD TOP CONNECTOR 1	near LH rear wheel well		

04/99

7000.0-4

1998



COMPONENT LOCATION CHART

Z3

COMP.	DESCRIPTION	LOCATION	7100.0	8500.0
E105	HEAT/A/C CONTROL PANEL ILLUMINATION	center of dash	21-3	
E106	HEAT/A/C CONTROL PANEL ILLUMINATION	center of dash	21-3	
E800	FRONT LEFT INTERIOR LIGHT	near interior rear view mirror		
F97	FUSIBLE LINK	in RH side of luggage compartment	03-1	
G1	BATTERY	in RH side of luggage compartment	03-1	
G5	DRIVER'S AIR BAG GAS GENERATOR	behind steering wheel		
G6	PASSENGER'S AIR BAG GAS GENERATOR	behind glove box above		
G12	DRIVER'S SIDE PYROTECHNICAL BELT TENSIONER	in LH front seat belt buckle	38-2	
G13	PASSENGER'S SIDE PYROTECHNICAL BELT TENSIONER	in RH front seat belt buckle	38-2	
G14	LEFT SIDE AIR BAG GAS GENERATOR	LH front door	41-3	
G15	RIGHT SIDE AIR BAG GAS GENERATOR	RH front door	39-2	
G6430	B+ JUMP START JUNCTION POINT	rear RH side of engine compartment	03-2	
G6509	GENERATOR	front LH side of engine compartment	02-3	
H1w	ANTI-THEFT HORN (ALPINE)	rear LH side of engine compartment	09-1	
H2	LEFT HORN	under LH front bumper		
H3	RIGHT HORN	RH front of wheel well	13-2	
H4	RIGHT FRONT TURN LIGHT	front of vehicle		
H7	LEFT FRONT TURN LIGHT	front of vehicle		
H8	RIGHT FRONT AUXILIARY TURN LIGHT	front of vehicle		

04/99

7000.0-5

1998



COMPONENT LOCATION CHART

Z3

COMP.	DESCRIPTION	LOCATION	7100.0	8500.0
H9	LEFT FRONT AUXILIARY TURN LIGHT	front of vehicle		
H10	CHIME MODULE	below LH side of dash		
H34	HIGH LEVEL STOP LIGHT	on lift gate		
H50	RIGHT FRONT HIGH RANGE SPEAKER	in upper RH front door		
H51	RIGHT FRONT LOW RANGE SPEAKER	in lower RH A-pillar		
H52	RIGHT REAR LOW RANGE SPEAKER	in rear speaker box		
H54	RIGHT FRONT MIDRANGE SPEAKER	in upper RH front door		
H54z	REAR RIGHT MID-HIGH RANGE SPEAKER	in rear speaker box	40-3	
H55	LEFT FRONT MIDRANGE SPEAKER	in upper LH front door		
H55z	REAR LEFT MID-HIGH RANGE SPEAKER	in rear speaker box	42-1	
H57	LEFT REAR LOW RANGE SPEAKER	in rear speaker box		
H58	LEFT FRONT LOW RANGE SPEAKER	in lower LH A-pillar		
H59	LEFT FRONT HIGH RANGE SPEAKER	in upper LH front door		
H500	REAR WOOFER	in rear speaker box		
I1008	SEAT MAT	in passenger's seat area		
K2	HORN RELAY	rear LH side of engine compartment in Power Distribution Box	09-2	
K4	BLOWER RELAY	rear LH side of engine compartment in Power Distribution Box	09-2	
K9	UNLOADER RELAY, TERMINAL 15	rear LH side of engine compartment in Power Distribution Box	09-3	
K10	ABS RELAY	rear LH side of engine compartment in Power Distribution Box	09-3	
K16	HAZARD FLASHER RELAY	rear LH side of engine compartment in Power Distribution Box	09-2	
K19	COMPRESSOR CONTROL RELAY	rear LH side of engine compartment in Power Distribution Box	09-3	

04/99

7000.0-6

1998



COMPONENT LOCATION CHART

Z3

COMP.	DESCRIPTION	LOCATION	7100.0	8500.0
K21	NORMAL SPEED RELAY	rear LH side of engine compartment in Power Distribution Box	09-3	
K22	HIGH SPEED RELAY	rear LH side of engine compartment in Power Distribution Box	09-3	
K33a	AIR CONDITIONING RELAY, MOTRONIC	Power Distribution Box, rear LH side of engine compartment	08-3	
K46	HIGH BEAM LIGHT RELAY	footwell, driver's side (USA)	19-1	
K46z	DAY LIGHT RELAY MODULE	footwell, driver's side (CDN)		
K47	FRONT FOG LIGHT RELAY	rear LH side of engine compartment in Power Distribution Box	09-2	
K48	LOW BEAM LIGHT RELAY	rear LH side of engine compartment in Power Distribution Box	09-2	
K75	ABS PUMP MOTOR RELAY	rear LH side of engine compartment in Power Distribution Box	09-3	
K94	ENGINE CONTROL RELAY (ABS/ASC)	Power Distribution Box, rear LH side of engine compartment	08-3	
K95	VALVE RELAY (ABS/ASC)	Power Distribution Box, rear LH side of engine compartment	08-3	
K910	PASSENGER'S SEAT TILT ADJUST CUT-OFF RELAY	underside of RH front seat	41-1	
K911	PASSENGER'S SEAT LENGTH ADJUST CUT-OFF RELAY	underside of RH front seat	41-1	
K920	DRIVER'S SEAT TILT ADJUST CUT-OFF RELAY	underside of LH front seat	42-2	
K921	DRIVER'S SEAT LENGTH ADJUST CUT-OFF RELAY	underside of LH front seat	42-2	
K6300	ENGINE CONTROL MODULE RELAY	rear RH side of engine compartment in E-Box (6-cylinder)	01-1	
K6300	ENGINE CONTROL MODULE RELAY	rear RH side of engine compartment in E-Box (4-cylinder)	36-3	
K6301w	FUEL PUMP RELAY	below LH side of dash	19-1	
K6304	SECONDARY AIR PUMP RELAY	rear RH side of engine compartment in E-Box (6-cylinder)	01-1	
K6304	SECONDARY AIR PUMP RELAY	rear LH side of engine compartment (4-cylinder)	37-1	

04/99

7000.0-7

1998



COMPONENT LOCATION CHART

Z3

COMP.	DESCRIPTION	LOCATION	7100.0	8500.0
K6326	UNLOADER RELAY, TERMINAL 15	rear RH side of engine compartment in E-Box (6-cylinder)	01-1	
K6326	UNLOADER RELAY, TERMINAL 15	rear RH side of engine compartment in E-Box (4-cylinder)	36-3	
K6394	COMPRESSOR RELAY	TIRE INFLATION SYSTEM		
K18363	CONVERTIBLE TOP RELAY I (CLOSE) . . .	in LH side of luggage compartment	25-3	
K18364	CONVERTIBLE TOP RELAY II (OPEN) . . .	in LH side of luggage compartment	25-3	
M2 . . .	FUEL PUMP	in fuel tank		
M3 . . .	WIPER MOTOR	rear of engine compartment		
M4 . . .	WASHER PUMP	front RH side of engine compartment on washer fluid reservoir		
M7 . . .	HEADLIGHT/FOG LIGHT WASHER PUMP	front RH side of engine compartment on washer fluid reservoir		
M9 . . .	AUXILIARY FAN MOTOR	behind front grille		
M12 . .	DRIVER'S DOOR LOCK MOTOR	driver's door		
M13 . .	PASSENGER'S DOOR LOCK MOTOR . . .	passenger's door		
M17 . .	LUGGAGE COMPARTMENT LOCK MOTOR	rear side of luggage compartment behind trim panel		
M21 . .	DRIVER'S WINDOW MOTOR	in driver's door	17-2	
M23 . .	PASSENGER'S WINDOW MOTOR	in passenger's door	18-3	
M25 . .	CRUISE CONTROL ACTUATOR (TEMPOMAT)	rear LH side of engine compartment	08-1	
M30 . .	BLOWER MOTOR	rear of engine compartment		
M51 . .	DRIVER'S SEAT MOVEMENT MOTOR . . .	under LH front seat	25-1	
M51 . .	DRIVER'S SEAT MOVEMENT MOTOR . . .	under LH front seat (WITH SPORT SEAT)	42-3	
M52 . .	DRIVER'S SEAT HEIGHT MOTOR	under LH front seat	25-1	

04/99

7000.0-8

1998



COMPONENT LOCATION CHART

Z3

COMP.	DESCRIPTION	LOCATION	7100.0	8500.0
M52 ..	DRIVER'S SEAT HEIGHT MOTOR	under LH front seat (WITH SPORT SEAT)	42-3	
M59 ..	PASSENGER'S SEAT HEIGHT MOTOR ..	under RH front seat	24-1	
M60 ..	PASSENGER'S SEAT MOVEMENT MOTOR	under RH front seat	24-1	
M93 ..	AUXILIARY THROTTLE POSITION MOTOR (ADS)	front of engine	35-3	
M101 .	CONVERTIBLE TOP MOTOR	in LH side of luggage compartment	25-3	
M111 .	FRESH AIR RECIRCULATION MOTOR ...	RH side of LH footwell	21-2	
M805 .	ELECTRICAL COMPRESSOR	TIRE INFLATION SYSTEM		
M6506	E-BOX FAN	in E-Box		
M6510	STARTER	rear LH side of engine compartment	02-2	
N5 ...	ANALOG CLOCK	center console		
N8 ...	ANTENNA AMPLIFIER AM/FM	in LH side of luggage compartment behind trim panel		
N9 ...	RADIO	center console		
N12w .	ANTI-THEFT CONTROL MODULE (ALPINE)	behind glove box		
N17 ..	CRASH CONTROL MODULE	footwell, driver's side	19-1	
N22 ..	CD CHANGER	in LH forward side of luggage compartment		
P90 ..	FRONT POWER DISTRIBUTION BOX ...	rear LH side of engine compartment		
P95 ..	AUXILIARY FUSE BOX	below LH side of dash		
P97 ..	AUXILIARY FUSE BOX	below LH side of dash	19-1	
R11 ...	BLOWER RESISTORS	rear of engine compartment behind firewall		

04/99

7000.0-9

1998



COMPONENT LOCATION CHART

Z3

COMP.	DESCRIPTION	LOCATION	7100.0	8500.0
R31 ..	AUXILIARY THROTTLE POSITION SENSOR	front of engine (6-cylinder)	33-3	
R31 ..	AUXILIARY THROTTLE POSITION SENSOR	front of engine (4-cylinder)	37-3	
R6252	THROTTLE POSITION SENSOR	front of engine (4-cylinder)	10-3	
R6252	THROTTLE POSITION SENSOR	front of engine (6-cylinder)	33-3	
S2	IGNITION SWITCH	LH side of dash		
S3	AUTOMATIC TRANSMISSION RANGE SWITCH	center console	22-1	
S4	HORN SWITCH	on steering wheel		
S5	WIPER/WASHER SWITCH	LH side of dash RH side of steering column above		
S6	ASC SWITCH	center console		
S7	COMBINATION SWITCH	LH side of dash LH side of steering column above		
S8	LIGHT SWITCH	LH side of dash		
S10 ..	FOG LIGHT SWITCH	LH side of dash		
S13 ..	PASSENGER'S DOOR JAMB SWITCH ...	RH B-pillar	26-1	
S14 ..	DRIVER'S DOOR JAMB SWITCH	LH B-pillar	27-1	
S17 ..	MIRROR CONTROL SWITCH	in upper LH front door		
S18 ..	HAZARD SWITCH	center console bottom		
S20w .	RADIO ANTI-THEFT SWITCH	center console (radio and console removed)	38-1	
S21w .	ENGINE HOOD SWITCH	near LH headlight assembly	29-1	
S28 ..	CRUISE CONTROL SWITCH	LH side of dash RH side of steering column above		
S30 ..	BRAKE LIGHT SWITCH	LH footwell	20-1	

04/99

7000.0-10

1998



COMPONENT LOCATION CHART

Z3

COMP.	DESCRIPTION	LOCATION	7100.0	8500.0
S31	PARK BRAKE SWITCH	center console on rear of park brake lever		
S32	CLUTCH SWITCH	LH footwell	20-1	
S36	TEMPERATURE SWITCH	front RH side of engine compartment	30-1	
S36y	DOUBLE TEMPERATURE SWITCH	front RH side of engine compartment	30-1	
S47	DRIVER'S DOOR LOCK SWITCH	in driver's door	17-1	
S49	PASSENGER'S DOOR LOCK SWITCH	in passenger's door		
S51	DRIVER'S SEAT, SEAT CONTROL SWITCH	LH front seat		
S53	DRIVER'S SEAT, SEAT HEATER SWITCH	center console (LATE PRODUCTION)	23-1	
S53	DRIVER'S SEAT, SEAT HEATER SWITCH	center console (behind seat) (EARLY PRODUCTION)		
S54	PASSENGER'S SEAT, SEAT HEATER SWITCH	center console (LATE PRODUCTION)	23-1	
S54	PASSENGER'S SEAT, SEAT HEATER SWITCH	center console (behind seat) (EARLY PRODUCTION)		
S56	PASSENGER'S SEAT, SEAT CONTROL SWITCH	RH front seat		
S58	DRIVER'S SEAT BELT SWITCH	in LH front seat belt buckle		
S59	PASSENGER'S SEAT BELT SWITCH	in RH front seat belt buckle		
S75	BLOWER SWITCH	center of dash	21-3	
S76	REAR WINDOW DEFOGGER SWITCH	center console		
S126y	DRIVER'S POWER WINDOW SWITCH	center console near gearshift lever		
S127y	PASSENGER'S POWER WINDOW SWITCH	center console near gearshift lever		
S143	CONVERTIBLE TOP ACTUATING SWITCH	center console		

04/99

7000.0-1-1

1998



COMPONENT LOCATION CHART

Z3

COMP.	DESCRIPTION	LOCATION	7100.0	8500.0
S164	CONVERTIBLE TOP END-POSITION MICRO SWITCH	at convertible top linkage	17-3	
S198	JET HEATER THERMOSWITCH	on front LH wheel well	12-1	
S220	AIR CONDITIONING/RECIRCULATING SWITCH ASSEMBLY	center console	01-3	
S221	EVAPORATOR CONTROLLER	RH side of LH footwell	21-2	
S232	COMPRESSOR MAIN SWITCH	TIRE INFLATION SYSTEM		
S235	STARTER IMMOBILIZATION SWITCH	LH footwell		
S408	INTERIOR LIGHT SWITCH	near interior rear view mirror	28-2	
S531	TEMPERATURE WHEEL SWITCH	center of dash	21-3	
S559	PASSENGER'S AIR BAG CUT-OFF SWITCH	center console		
S826	LUGGAGE COMPARTMENT LIGHT SWITCH	underside of luggage compartment lid		
S910	DRIVER'S SEAT LIMIT SWITCH	in driver's seatback		
S911	PASSENGER'S SEAT LIMIT SWITCH	in passenger's seatback		
S8503	PROGRAM SWITCH	center console	22-1	
S8507	KICK-DOWN SWITCH	behind gas pedal	19-3	
S8511	REVERSING LIGHT SWITCH	LH side of transmission	14-2	
T6151	CYL. 1 IGNITION COIL	RH side of engine compartment		
T6152	CYL. 2 IGNITION COIL	RH side of engine compartment		
T6153	CYL. 3 IGNITION COIL	RH side of engine compartment		
T6154	CYL. 4 IGNITION COIL	RH side of engine compartment		

04/99

7000.0-12

1998



COMPONENT LOCATION CHART

Z3

COMP.	DESCRIPTION	LOCATION	7100.0	8500.0
T6155	CYL. 5 IGNITION COIL	RH side of engine compartment		
T6156	CYL. 6 IGNITION COIL	RH side of engine compartment		
V7	ASC DIODE	Power Distribution Box rear LH side of engine compartment		
X0	B+ JUNCTION POINT	rear LH side of engine compartment in Power Distribution Box	02-1	
X2	BATTERY B+ START POINT	rear LH side of engine compartment in Power Distribution Box		
X4	GROUND	LH side of engine compartment		
X11 ...	(42 PINS, BLACK)	behind glove box		09-3
X16 ..	(26 PINS, NATURAL)	LH side of dash rear side of instrument cluster, A2w	20-2	00-2
X17 ..	(26 PINS, BLUE)	LH side of dash rear side of instrument cluster, A2w	20-2	00-2
X20 ..	(25 PINS, BLACK)	rear LH side of engine compartment	08-1	04-4
X22 ..	(26 PINS, BLUE)	behind glove box	00-2	00-2
X29 ..	(1 PIN, —)	LH side of steering column		
X31 ..	(12 PINS, BLACK)	LH side of engine compartment		01-6
X32 ..	(12 PINS, NATURAL)	on steering column	19-2	02-4
X33 ..	(12 PINS, BLACK)	on steering column	19-2	02-4
X35 ..	(4 PINS, BLACK)	RH side of LH footwell	21-1	01-5
X44 ..	(9 PINS, BLACK)	Power Distribution Box rear LH side of engine compartment		03-4
X45 ..	(9 PINS, BLACK)	Power Distribution Box rear LH side of engine compartment		03-4
X50 ..	(9 PINS, BLACK)	Power Distribution Box, rear LH side of engine compartment		03-4
X51 ..	(9 PINS, BLACK)	Power Distribution Box rear LH side of engine compartment		03-4
X52 ..	(9 PINS, BLACK)	Power Distribution Box rear LH side of engine compartment		03-4
X53 ..	(9 PINS, BLACK)	Power Distribution Box rear LH side of engine compartment		03-4

04/99

7000.0-13

1998



COMPONENT LOCATION CHART

Z3

COMP.	DESCRIPTION	LOCATION	7100.0	8500.0
X54 ..	(9 PINS, BLACK)	Power Distribution Box rear LH side of engine compartment		03-4
X56 ..	(9 PINS, BLACK)	Power Distribution Box rear LH side of engine compartment		03-4
X58 ..	(9 PINS, BLACK)	Power Distribution Box rear LH side of engine compartment		03-4
X63 ..	(9 PINS, BLACK)	Power Distribution Box rear LH side of engine compartment		03-4
X64 ..	(9 PINS, BLACK)	Power Distribution Box rear LH side of engine compartment		03-4
X65 ..	(9 PINS, BLACK)	below LH side of dash		03-4
X69 ..	(25 PINS, GRAY)	rear LH side of engine compartment	08-1	04-4
X70 ..	(8 PINS, BLACK)	rear LH side of engine compartment	08-1	06-2
X72 ..	(6 PINS, NATURAL)	on steering column	19-2	05-3
X74 ..	(50 PINS, YELLOW)	below center console	22-2	11-2
X78 ..	(4 PINS, BLACK)	on steering column	20-1	03-1
X82 ..	(3 PINS, BLACK)	under radiator	13-1	05-5
X85 ..	(3 PINS, BLACK)	rear LH side of engine compartment	11-1	05-5
X87 ..	(3 PINS, BLACK)	RH top of radiator	30-1	02-5
X105 .	(2 PINS, GRAY)	on underside of engine hood	16-2	
X106 .	(2 PINS, GRAY)	on underside of engine hood	16-2	
X107 .	(2 PINS, GRAY)	front RH side of engine compartment on washer fluid reservoir		
X111 ..	(2 PINS, BLACK)	rear LH side of engine compartment	09-1	
X113 ..	(3 PINS, GRAY)	behind RH front wheel	13-3	06-3
X114 ..	(3 PINS, GRAY)	behind LH front wheel	12-2	06-3
X118 ..	(2 PINS, BLACK)	behind LH front wheel	12-2	
X121 .	(2 PINS, WHITE)	LH footwell	20-1	

04/99

7000.0-14

1998



COMPONENT LOCATION CHART

Z3

COMP.	DESCRIPTION	LOCATION	7100.0	8500.0
X123	(2 PINS, GRAY)	front RH side of engine compartment on washer fluid reservoir		
X127	(4 PINS, BLACK)	front RH side of engine compartment	30-2	05-4
X128	(3 PINS, BLACK)	front LH side of engine compartment	11-2	02-5
X130	(2 PINS, GRAY)	near front LH headlight	29-2	
X131	(2 PINS, BLACK)	near front LH headlight	29-2	
X132	(2 PINS, BLACK)	on front LH wheel well	12-1	
X133	(2 PINS, BLACK)	on front LH wheel well	13-2	
X134	(2 PINS, BLACK)	near front RH headlight	29-3	
X135	(2 PINS, GRAY)	near front RH headlight	29-3	
X137	(3 PINS, BLACK)	front RH side of engine compartment	30-3	02-5
X142	(3 PINS, GRAY)	under LH rear of car, ASC		06-3
X142	(2 PINS, GRAY)	under LH rear of car, ABS	16-1	
X143	(3 PINS, GRAY)	under RH rear of car, ASC		06-3
X143	(2 PINS, GRAY)	under RH rear of car, ABS	15-3	
X163	(3 PINS, BLACK)	front RH side of engine compartment on washer fluid reservoir near RH headlight assembly	30-2	05-5
X165	GROUND	front RH side of engine compartment	04-2	
X166	GROUND	front LH side of engine compartment	05-1	
X170	GROUND	behind LH footwell speaker grille	07-2	
X256	(26 PINS, BLACK)	RH A-pillar	18-1	03-5
X257	(26 PINS, BLACK)	LH A-pillar	16-3	03-5
X271	(12 PINS, BLACK)	LH side of dash rear side of instrument cluster, A2w	20-2	01-3

04/99

7000.0-15

1998



COMPONENT LOCATION CHART

Z3

COMP.	DESCRIPTION	LOCATION	7100.0	8500.0
X275	(4 PINS, NATURAL)	under LH front seat	25-2	03-1
X275	(4 PINS, NATURAL)	under LH front seat (WITH SPORT SEAT)	42-3	03-1
X279	(4 PINS, NATURAL)	under RH front seat	24-2	03-1
X279	(4 PINS, NATURAL)	under RH front seat (WITH SPORT SEAT)	41-2	03-1
X285	(15 PINS, BLUE)	behind glove box	00-2	05-1
X295	(8 PINS, BLACK)	on steering column	19-2	03-4
X311	(3 PINS, BLACK)	in luggage compartment lid	28-1	01-1
X315	(2 PINS, BLACK)	in luggage compartment lid	28-1	
X316	(4 PINS, YELLOW)	center console near gearshift lever		07-1
X318	(8 PINS, BLACK)	in RH rear side of luggage compartment behind RH rear light assembly	03-1	02-1
X319	(8 PINS, BLACK)	in LH side of luggage compartment behind trim panel		02-1
X322	(6 PINS, BLACK)	footwell, driver's side	19-1	03-6
X324	(4 PINS, YELLOW)	center console near gearshift lever		07-1
X333	(4 PINS, NATURAL)	rear of engine compartment below center of cowl		03-1
X336	(3 PINS, BLACK)	in upper RH A-pillar		01-1
X351	(3 PINS, BLACK)	RH B-pillar	26-1	01-1
X352	(3 PINS, BLACK)	LH B-pillar	27-1	01-1
X357	(2 PINS, WHITE)	near interior rear view mirror	28-2	
X371	(3 PINS, BLACK)	near front LH headlight	29-1	02-5
X372	(2 PINS, GRAY)	rear LH side of engine compartment	09-1	
X379	(1 PIN, NATURAL)	HARD TOP CONNECTOR 1		
X380	(1 PIN, NATURAL)	HARD TOP CONNECTOR 1		

04/99

7000.0-16

1998



COMPONENT LOCATION CHART

Z3

COMP.	DESCRIPTION	LOCATION	7100.0	8500.0
X383	(2 PINS, BLACK)	on differential	15-2	
X389	(2 PINS, BLACK)	LEFT FRONT AUXILIARY TURN LIGHT		
X390	(2 PINS, BLACK)	RIGHT FRONT AUXILIARY TURN LIGHT		
X400	(8 PINS, BLACK)	center console (behind seat)		02-1
X413	(3 PINS, BLACK)	HIGH LEVEL STOP LIGHT		01-1
X423	(1 PIN, —)	below center console on rear of park brake lever		
X424	(1 PIN, —)	in LH side of luggage compartment behind trim panel		
X494	GROUND	below center console	07-1	
X503	(12 PINS, BLACK)	LH side of dash	20-3	07-2
X504	(4 PINS, NATURAL)	LH side of dash	20-3	03-1
X511	(8 PINS, BLACK)	center console	22-1	02-1
X516	(5 PINS, BLACK)	center console		02-6
X521	(6 PINS, BLUE)	center console		04-5
X522	(3 PINS, NATURAL)	RH side of LH footwell		04-3
X531	(1 PIN, NATURAL)	center console	22-3	
X532	(2 PINS, BLACK)	center console	22-3	
X537	(3 PINS, BLACK)	REAR LEFT MID-HIGH RANGE SPEAKER	42-1	01-1
X538	(3 PINS, BLACK)	REAR RIGHT MID-HIGH RANGE SPEAKER	40-3	01-1
X539	(2 PINS, BLACK)	center console (radio and console removed)	38-1	
X605	(12 PINS, BLACK)	in RH side of luggage compartment behind trim panel	27-3	08-4
X606	(26 PINS, BLACK)	in RH side of luggage compartment behind trim panel	27-3	00-2
X623	(4 PINS, BLACK)	in driver's door	17-2	07-1

04/99

7000.0-17

1998



COMPONENT LOCATION CHART

Z3

COMP.	DESCRIPTION	LOCATION	7100.0	8500.0
X624	(4 PINS, BLACK)	in passenger's door	18-3	07-1
X625	(6 PINS, BLACK)	in driver's door	17-2	08-2
X641	(6 PINS, BLACK)	in passenger's door	18-2	07-4
X651	(6 PINS, YELLOW)	center console (LATE PRODUCTION)	23-1	04-5
X651	(6 PINS, YELLOW)	center console (behind seat) (EARLY PRODUCTION)		04-5
X658	(6 PINS, YELLOW)	center console (LATE PRODUCTION)	23-1	04-5
X658	(6 PINS, YELLOW)	center console (behind seat) (EARLY PRODUCTION)		04-5
X660	(6 PINS, BLACK)	LH front door behind door panel		07-4
X693	(1 PIN, NATURAL)	TIRE INFLATION SYSTEM		
X700	(1 PIN, —)	behind RH footwell speaker grille	23-3	
X701	(1 PIN, —)	behind LH footwell speaker grille		
X709	(2 PINS, BLACK)	underside of luggage compartment lid, near license plate		
X710	(2 PINS, BLACK)	underside of luggage compartment lid, near license plate		
X711	(2 PINS, BLACK)	in luggage compartment lid	28-1	
X712	(1 PIN, BLACK)	in luggage compartment		
X713	(2 PINS, BLACK)	under RH rear of car	15-3	
X726	(2 PINS, NATURAL)	under LH front seat	25-1	
X726	(2 PINS, NATURAL)	under LH front seat (WITH SPORT SEAT)	42-3	
X728	(2 PINS, BLACK)	under LH front seat	25-1	
X728	(2 PINS, BLACK)	under LH front seat (WITH SPORT SEAT)	42-3	
X733	(4 PINS, BLACK)	under LH front seat	25-2	03-1
X733	(4 PINS, BLACK)	under LH front seat (WITH SPORT SEAT)	42-3	03-1

04/99

7000.0-18

1998



COMPONENT LOCATION CHART

Z3

COMP.	DESCRIPTION	LOCATION	7100.0	8500.0
X734	(2 PINS, NATURAL)	under RH front seat	24-1	
X734	(2 PINS, NATURAL)	under RH front seat (WITH SPORT SEAT)	41-1	
X737	(2 PINS, BLACK)	under RH front seat	24-1	
X737	(2 PINS, BLACK)	under RH front seat (WITH SPORT SEAT)	41-2	
X740	(4 PINS, BLACK)	under RH front seat	24-2	03-1
X740	(4 PINS, BLACK)	under RH front seat (WITH SPORT SEAT)	41-2	03-1
X742	(2 PINS, YELLOW)	in passenger's door		
X744	(4 PINS, GRAY)	in passenger's door	18-3	05-4
X746	(3 PINS, YELLOW)	in passenger's door	18-3	10-5
X747	(2 PINS, YELLOW)	in driver's door	17-1	
X749	(2 PINS, GRAY)	in driver's door	17-2	
X753	(3 PINS, YELLOW)	in driver's door	17-2	10-5
X766	(2 PINS, BLACK)	LH front of vehicle		
X767	(2 PINS, BLACK)	RH front of vehicle		
X768	(2 PINS, BLACK)	on front LH wheel well	12-1	
X769	(2 PINS, BLACK)	RH front of wheel well	13-2	
X770	(2 PINS, YELLOW)	on front LH wheel well (4-cylinder)	12-1	
X770	(2 PINS, YELLOW)	in RH front bumper (6-cylinder)	35-2	
X771	(2 PINS, NATURAL)	RH side of LH footwell	21-2	
X778	(4 PINS, BLACK)	under LH front seat	42-2	07-1
X782	(3 PINS, ORANGE)	behind glove box above	00-3	07-5
X783	(3 PINS, ORANGE)	underside of steering column	38-3	07-5

04/99

7000.0-19

1998



COMPONENT LOCATION CHART

Z3

COMP.	DESCRIPTION	LOCATION	7100.0	8500.0
X861	GROUND	LH side of engine compartment	05-1	
X898	(8 PINS, BLACK)	under rear storage compartment	26-2	08-3
X904	(4 PINS, BLACK)	RH side of LH footwell		03-1
X905	(7 PINS, BLACK)	center of dash	21-3	09-2
X1014	(1 PIN, BLACK)	center console	22-3	
X1098	(3 PINS, BLACK)	LH side of dash	20-3	01-1
X1116	GROUND	in LH side of luggage compartment	06-3	
X1148	(2 PINS, BLACK)	on front LH wheel well	12-1	
X1155	(2 PINS, BLACK)	center console		
X1161	(9 PINS, BLACK)	Power Distribution Box rear LH side of engine compartment		03-4
X1166	GROUND	behind glove box	04-3	
X1170	(42 PINS, BLACK)	behind glove box	00-1	09-3
X1171	(55 PINS, NATURAL)	behind glove box	00-3	11-3
X1175	(83 PINS, NATURAL)	behind glove box	00-3	12-4
X1176	(25 PINS, BLACK)	rear LH side of engine compartment	35-3	04-4
X1178	(2 PINS, WHITE)	center console	27-2	
X1193	(3 PINS, BLACK)	center console	22-1	01-1
X1213	(2 PINS, BLACK)	center console		
X1255	(4 PINS, BLACK)	TIRE INFLATION SYSTEM		01-5
X1265	(1 PIN, NATURAL)	HARD TOP CONNECTOR 1		
X1266	(1 PIN, NATURAL)	HARD TOP CONNECTOR 1		
X1380	(1 PIN, —)	behind RH footwell speaker grille	23-3	

04/99

7000.0-20

1998



COMPONENT LOCATION CHART

Z3

COMP.	DESCRIPTION	LOCATION	7100.0	8500.0
X1381	(1 PIN, —)	behind LH footwell speaker grille		
X1439	(2 PINS, BLACK)	center console		
X1441	GROUND	below center console	07-3	
X1517	(6 PINS, BLACK)	RH side of LH footwell	21-2	09-1
X1588	(2 PINS, BLACK)	below LH side of dash	19-1	
X1652	(5 PINS, BLACK)	behind glove box	00-1	12-1
X1659	(15 PINS, YELLOW)	behind glove box	00-1	05-1
X1715	(6 PINS, BLACK)	in RH side of luggage compartment	27-3	04-5
X1883	(2 PINS, YELLOW)	LH front door	41-3	
X1884	(2 PINS, YELLOW)	RH front door	39-2	
X1885	(3 PINS, BLACK)	under LH front seat	39-3	01-4
X1886	(3 PINS, BLACK)	under RH front seat	39-1	01-4
X1890	(3 PINS, BLACK)	under radiator		05-5
X2213	(15 PINS, NATURAL)	LH side of engine compartment		05-1
X2227	(4 PINS, BLUE)	center console		07-1
X3040	(2 PINS, BLACK)	TIRE INFLATION SYSTEM		
X3158	(1 PIN, NATURAL)	TIRE INFLATION SYSTEM		
X5115	(2 PINS, BLACK)	center console (radio and console removed)	38-1	
X6000	(88 PINS, NATURAL)	rear RH side of engine compartment in E-Box		00-1
X6002	(20 PINS, BLACK)	rear RH side of engine compartment		04-1
X6031	(12 PINS, BLACK)	rear LH side of engine compartment	08-1	01-6
X6091	(30 PINS, BLACK)	rear of engine compartment on firewall	10-1	01-2

04/99

7000.0-21

1998



Z3

COMPONENT LOCATION CHART

COMP.	DESCRIPTION	LOCATION	7100.0	8500.0
X6101	(2 PINS, BLACK)	top center of engine		
X6102	(2 PINS, BLACK)	top center of engine		
X6103	(2 PINS, BLACK)	top center of engine		
X6104	(2 PINS, BLACK)	top center of engine		
X6105	(2 PINS, BLACK)	top center of engine		
X6106	(2 PINS, BLACK)	top center of engine		
X6120	(2 PINS, BLACK)	LH side of engine compartment (4-cylinder)	08-2	
X6120	(2 PINS, BLACK)	LH side of engine compartment (6-cylinder)	34-2	
X6130	(3 PINS, BLACK)	front of engine (4-cylinder)	10-3	10-2
X6130	(3 PINS, BLACK)	front of engine (6-cylinder)		10-2
X6131	(2 PINS, BLACK)	front LH side of engine compartment	11-3	
X6133	(2 PINS, BLACK)	rear RH side of engine compartment (6-cylinder)	31-2	
X6133	(2 PINS, BLACK)	LH side of engine compartment (4-cylinder)	37-2	
X6150	(10 PINS, BLACK)	rear RH side of engine compartment		10-1
X6150	(7 PINS, BLACK)	rear RH side of engine compartment	31-1	04-2
X6151	(3 PINS, GRAY)	top RH side of engine (4-cylinder)		09-4
X6151	(3 PINS, BLACK)	top RH side of engine (6-cylinder)		09-4
X6152	(3 PINS, GRAY)	top RH side of engine (4-cylinder)		09-4
X6152	(3 PINS, BLACK)	top RH side of engine (6-cylinder)		09-4
X6153	(3 PINS, BLACK)	top RH side of engine (4-cylinder)		09-4
X6153	(3 PINS, GRAY)	top RH side of engine (6-cylinder)		09-4
X6154	(3 PINS, GRAY)	top RH side of engine (4-cylinder)		09-4

04/99

7000.0-22

1998



COMPONENT LOCATION CHART

Z3

COMP.	DESCRIPTION	LOCATION	7100.0	8500.0
X6154	(3 PINS, BLACK)	top RH side of engine (6-cylinder)		09-4
X6155	(3 PINS, BLACK)	top RH side of engine		09-4
X6156	(3 PINS, BLACK)	top RH side of engine		09-4
X6163	(2 PINS, BLACK)	LH side of engine compartment (6-cylinder)	31-3	
X6163	(2 PINS, BLACK)	LH side of engine compartment (4-cylinder)	37-3	
X6203	(3 PINS, BLACK)	front of engine below intake manifold	33-1	10-2
X6204	(3 PINS, BLACK)	front of engine below intake manifold	33-1	10-2
X6205	(2 PINS, BLACK)	front LH side of engine compartment (4-cylinder)	11-2	
X6205	(2 PINS, BLACK)	front LH side of engine compartment (6-cylinder)	34-1	
X6207	(4 PINS, BLACK)	LH side of engine compartment	33-3	10-4
X6209	(3 PINS, BLACK)	front of engine HALL EFFECT CAMSHAFT SENSOR		06-4
X6210	(4 PINS, BLACK)	under center of car	35-1	06-1
X6217	(4 PINS, GRAY)	front LH side of engine compartment	11-3	03-2
X6220	(4 PINS, BLACK)	under center of car	35-1	06-1
X6231	(2 PINS, BLACK)	RH front of engine (4-cylinder)	10-2	
X6231	(2 PINS, BLACK)	front of engine (6-cylinder)	32-2	
X6232	(4 PINS, BLACK)	RH front of engine	10-2	06-1
X6238	(2 PINS, BLACK)	RH side of oil filter	32-2	
X6240	(4 PINS, BLACK)	LH side of engine near starter (4-cylinder)	02-2	06-1
X6240	(4 PINS, BLACK)	LH side of engine (6-cylinder)	33-1	06-1
X6247	(2 PINS, BLACK)	under LH rear of car	36-1	
X6252	(3 PINS, BLACK)	front of engine (4-cylinder)	10-3	06-4

04/99

7000.0-23

1998



COMPONENT LOCATION CHART

Z3

COMP.	DESCRIPTION	LOCATION	7100.0	8500.0
X6252	(3 PINS, BLACK)	front of engine (6-cylinder)	33-3	10-2
X6256	(4 PINS, BLACK)	rear of engine compartment		10-3
X6263	(2 PINS, BLACK)	under LH center of car	36-2	
X6275	(2 PINS, BLACK)	top center of engine	31-3	
X6300	(9 PINS, BLACK)	rear RH side of engine compartment in E-Box		03-4
X6301	(9 PINS, BLACK)	below LH side of dash		03-4
X6304	(9 PINS, BLACK)	rear RH side of engine compartment in E-Box (6-cylinder)		03-4
X6304	(9 PINS, BLACK)	rear LH side of engine compartment (4-cylinder)		03-4
X6326	(9 PINS, BLACK)	rear RH side of engine compartment in E-Box		03-4
X6394	(9 PINS, BLACK)	TIRE INFLATION SYSTEM		03-4
X6430	CABLE SOCKET B+ JUMP START JUNCTION POINT	rear RH side of engine compartment		
X6431	CABLE SOCKET B+ JUMP START JUNCTION POINT	rear RH side of engine compartment		
X6432	CABLE SOCKET B+ JUMP START JUNCTION POINT	rear RH side of engine compartment		
X6454	GROUND	rear RH side of engine compartment (4-cylinder)	04-1	
X6454	GROUND	rear RH side of engine compartment (6-cylinder)	04-2	
X6455	GROUND	rear RH side of engine compartment	04-2	
X6456	GROUND	rear RH side of engine compartment (4-cylinder)	04-1	
X6456	GROUND	rear RH side of engine compartment (6-cylinder)	06-1	
X6500	(6 PINS, BLACK)	under rear storage compartment	40-1	06-5
X6501	(3 PINS, BLACK)	under rear storage compartment	40-1	02-5

04/99

7000.0-24

1998



COMPONENT LOCATION CHART

Z3

COMP.	DESCRIPTION	LOCATION	7100.0	8500.0
X6506	(2 PINS, BLACK)	in E-Box		
X6509	CABLE SOCKET ALTERNATOR B+	front LH side of engine compartment	02-3	
X6510	CABLE SOCKET STARTER, TERMINAL 50	rear LH side of engine compartment at starter	02-2	
X6511	CABLE SOCKET STARTER, TERMINAL 30h	rear LH side of engine compartment at starter		
X6512	CABLE SOCKET STARTER, TERMINAL 30	rear LH side of engine compartment at starter	02-2	
X6524	(3 PINS, BLACK)	front LH side of engine compartment		10-2
X6550	(2 PINS, BLACK)	under LH center of car	34-3	
X7509	CABLE SOCKET ALTERNATOR, TERMINAL D+	front LH side of engine compartment	02-3	
X8500	(88 PINS, NATURAL)	rear RH side of engine compartment in E-Box		00-1
X8503	(6 PINS, YELLOW)	center console	22-1	04-5
X8505	(16 PINS, BLACK)	on RH side of transmission	15-1	11-4
X8507	(1 PIN, BLACK)	behind gas pedal	19-3	
X8511	(2 PINS, BLACK)	LH side of transmission	14-2	
X8516	(2 PINS, BLACK)	LH side of transmission		
X9001	(2 PINS, BLACK)	center console		
X9002	(2 PINS, BLACK)	center console		
X9003	(2 PINS, BLACK)	center console		
X9170	CABLE SOCKET GROUND	LH side of engine compartment		
X9633	GROUND	behind LH footwell speaker grille	07-2	
X9770	(4 PINS, NATURAL)	center console		10-4

04/99

7000.0-25

1998



COMPONENT LOCATION CHART

Z3

COMP.	DESCRIPTION	LOCATION	7100.0	8500.0
X9990	(3 PINS, BLACK)	in driver's seatback		11-1
X9991	(10 PINS, BLACK)	underside of LH front seat	42-2	12-2
X9994	(3 PINS, BLACK)	in passenger's seatback		11-1
X9995	(10 PINS, BLACK)	underside of RH front seat	41-1	12-2
X9997	(2 PINS, ORANGE)	behind steering wheel		
X10010	GROUND	behind glove box	04-3	
X10013	(2 PINS, NATURAL)	behind steering wheel		
X10054	(8 PINS, BLACK)	RH side of LH footwell	21-1	02-1
X10059	(3 PINS, BLACK)	center console		05-2
X10065	(2 PINS, WHITE)	LH footwell	14-1	
X10088	(2 PINS, BLACK)	front RH side of engine compartment	30-3	
X10094	(2 PINS, BLACK)	front of engine	35-3	
X10098	(1 PIN, NATURAL)	Power Distribution Box rear LH side of engine compartment		
X10099	(1 PIN, —)	Power Distribution Box rear LH side of engine compartment		
X10182	(18 PINS, BLACK)	behind glove box		07-3
X10214	(3 PINS, BLACK)	under LH front seat	42-2	10-5
X10215	(3 PINS, BLACK)	under RH front seat	41-1	10-5
X10216	(3 PINS, BLACK)	in LH front seat belt buckle	38-2	07-5
X10217	(3 PINS, BLACK)	in RH front seat belt buckle	38-2	07-5
X10218	(3 PINS, NATURAL)	under RH front seat	24-2	01-1
X10218	(3 PINS, NATURAL)	under RH front seat (WITH SPORT SEAT)	41-2	01-1
X10239	(3 PINS, BLACK)	front of engine (6-cylinder)	33-3	10-2

04/99

7000.0-26

1998



COMPONENT LOCATION CHART

Z3

COMP.	DESCRIPTION	LOCATION	7100.0	8500.0
X10239	(3 PINS, BLACK)	front of engine (4-cylinder)	37-3	10-2
X10241	(3 PINS, BLACK)	front RH side of engine compartment		05-5
X10244	(1 PIN, BLACK)	behind glove box	24-3	
X10245	(12 PINS, BLACK)	center console	01-3	01-3
X10246	(12 PINS, BLACK)	in rear left speaker box	26-3	01-3
X10260	(3 PINS, NATURAL)	near steering column	01-2	01-1
X10262	(9 PINS, BLACK)	below LH side of dash		03-4
X10263	(6 PIN, BLACK)	center console		04-5
X10299	(4 PINS, BLACK)	RH rear wheel well	17-3	03-1
X11104	(1 PIN, —)	near interior rear view mirror	28-2	
X11105	(1 PIN, —)	near interior rear view mirror	28-2	
X11106	(1 PIN, —)	near interior rear view mirror	28-2	
X11209	(4 PINS, BLACK)	near RH rear wheel well	17-3	03-1
X11287	CONNECTORS SOLDERED UP	center of dash		
X11379	(3 PINS, BLACK)	RH top of radiator	30-1	05-5
X11402	(3 PINS, YELLOW)	in luggage compartment lid		01-1
X11403	(3 PINS, YELLOW)	in luggage compartment lid		01-1
X13004	GROUND	behind glove box	04-3	
X13006	GROUND	in LH side of luggage compartment	05-3	
X13016	GROUND	in LH side of luggage compartment	05-2	
X13017	(2 PINS, BLUE)	hard top		
X13025	(12 PINS, BLACK)	behind glove box	24-3	02-4

04/99

7000.0-27

1998



COMPONENT LOCATION CHART

Z3

COMP.	DESCRIPTION	LOCATION	7100.0	8500.0
X13032	GROUND	under rear storage compartment	06-2	
X13045	(6 PINS, NATURAL)	center console		04-5
X13146	(8 PINS, BLACK)	in LH side of luggage compartment	25-3	02-1
X13233	(1 PIN, BLACK)	center of dash behind center console		
X13252	(15 PINS, BLACK)	behind glove box	23-2	05-1
X13253	(26 PINS, YELLOW)	behind glove box	23-2	00-2
X13254	(26 PINS, GREEN)	behind glove box	23-2	00-2
X13287	(1 PIN, WHITE)	center of dash behind center console		
X18080	(1 PIN, BLACK)	in LH side of luggage compartment		
X18126	(17 PINS, BLACK)	center console behind radio		02-2
X18170	GROUND	below center console	07-1	
X18180	(3 PINS, BLACK)	in RH rear side of luggage compartment		01-1
X18190	(3 PINS, BLACK)	in driver's door	17-2	10-5
X18196	(10 PINS, BLACK)	LH A-pillar	16-3	02-3
X18198	(10 PINS, BLACK)	RH A-pillar	18-1	02-3
X18279	(2 PINS, GRAY)	in driver's door		
X18280	(2 PINS, GRAY)	in passenger's door		
X18333	(2 PINS, BLACK)	on instrument cluster		
X18349	(8 PINS, BLACK)	center console	01-3	08-3
X18350	(6 PINS, BLACK)	RH side of LH footwell	21-2	03-6
X18363	(9 PINS, BLACK)	in LH side of luggage compartment		03-4
X18364	(9 PINS, BLACK)	in LH side of luggage compartment		03-4

04/99

7000.0-28

1998



COMPONENT LOCATION CHART

Z3

COMP.	DESCRIPTION	LOCATION	7100.0	8500.0
X18516	(3 PINS, BLACK)	in passenger's door	18-3	10-5
X18518	(4 PINS, BLACK)	under RH front seat	41-1	07-1
X18520	(10 PINS, BLACK)	center console RADIO		
X18521	(10 PINS, BLACK)	RH side of luggage compartment CD CHANGER		
X18766	(9 PINS, BLACK)	Power Distribution Box, rear LH side of engine compartment		03-4
X18767	(9 PINS, BLACK)	Power Distribution Box, rear LH side of engine compartment		03-4
X18774	(4 PINS, NATURAL)	in rear speaker box	26-3	03-1
X18983	(2 PINS, BLACK)	center of dash		
X18984	(2 PINS, BLACK)	center of dash	21-3	
X18994	(3 PINS, YELLOW)	LH footwell		01-1
X19022	(3 PINS, BLACK)	behind front grille		05-5
X19023	(2 PINS, BLACK)	below LH side of dash		
X19245	(8 PINS, BLACK)	center console		02-1
X19527	(16 PINS, BLACK)	center console right	28-3	08-1
X19528	(3 PINS, NATURAL)	under rear storage compartment	40-2	02-5
X19565	(6 PINS, BLACK)	center console		12-3
X23146	(2 PINS, BLACK)	in LH side of luggage compartment	25-3	
X62001	(4 PINS, BLACK)	under center of car	14-3	06-1
X62002	(4 PINS, BLACK)	under center of car		06-1
X62101	(4 PINS, BLACK)	on catalytic converter		03-3
X62102	(4 PINS, BLACK)	on catalytic converter		03-3
X62201	(4 PINS, BLACK)	on catalytic converter		03-3

04/99

7000.0-29

1998



COMPONENT LOCATION CHART

Z3

COMP.	DESCRIPTION	LOCATION	7100.0	8500.0
X62202	(4 PINS, BLACK)	on catalytic converter		03-3
X90260	(3 PINS, BLACK)	near steering column	01-2	01-1
X91009	(2 PINS, BLACK)	under RH front seat	41-2	
Y1	ABS HYDRAULIC UNIT	LH side of engine compartment		
Y1w	ABS HYDRAULIC UNIT	rear LH side of engine compartment (4-cylinder)	08-2	
Y1w	ABS HYDRAULIC UNIT	rear LH side of engine compartment (6-cylinder)	35-3	
Y2	AIR CONDITIONING COMPRESSOR	front RH side of engine compartment		
Y4z	WATER VALVE	rear LH side of engine compartment	11-1	
Y5	DRIVER'S SIDE MIRROR	in upper LH front door		
Y6	PASSENGER'S SIDE MIRROR	in upper RH front door		
Y19	SHIFT-LOCK	center console	27-2	
Y6101	CYL. 1 FUEL INJECTION VALVE	on cylinder head		
Y6102	CYL. 2 FUEL INJECTION VALVE	on cylinder head		
Y6103	CYL. 3 FUEL INJECTION VALVE	on cylinder head		
Y6104	CYL. 4 FUEL INJECTION VALVE	on cylinder head		
Y6105	CYL. 5 FUEL INJECTION VALVE	on cylinder head		
Y6106	CYL. 6 FUEL INJECTION VALVE	on cylinder head		
Y6120	EVAPORATIVE EMISSION VALVE	LH side of engine compartment (4-cylinder)	08-2	
Y6120	EVAPORATIVE EMISSION VALVE	LH side of engine compartment (6-cylinder)	34-2	
Y6130	IDLE SPEED CONTROL VALVE	front of engine (4-cylinder)	10-3	
Y6130	IDLE SPEED CONTROL VALVE	front of engine (6-cylinder)		

04/99

7000.0-30

1998



COMPONENT LOCATION CHART

Z3

COMP.	DESCRIPTION	LOCATION	7100.0	8500.0
Y6131	INTAKE AIR RESONANCE CHANGE OVER VALVE	front of engine	11-3	
Y6133	AIR PUMP	LH side of engine compartment (4-cylinder)	37-2	
Y6133	AIR PUMP	rear RH side of engine compartment (6-cylinder)	31-2	
Y6163	SECONDARY AIR PUMP VALVE	LH side of engine compartment (6-cylinder)	33-2	
Y6163	SECONDARY AIR PUMP VALVE	LH side of engine compartment (4-cylinder)	37-3	
Y6263	FUEL CHANGE OVER VALVE	under LH center of car	36-2	
Y6275	VARIABLE CAMSHAFT CONTROL VALVE 1	on cylinder head	31-3	
Y6550	SOLENOID VALVE ("RUNNING LOSSES")	under LH center of car	34-3	
Y8505y	TRANSMISSION VALVE UNIT	on RH side of transmission	15-1	
Y8521	TRANSMISSION VALVE UNIT	on RH side of transmission	15-1	

04/99

7000.0-31

1998

7100.0 COMPONENT LOCATION VIEWS

ELECTRICAL CONTROL MODULE LOCATIONS

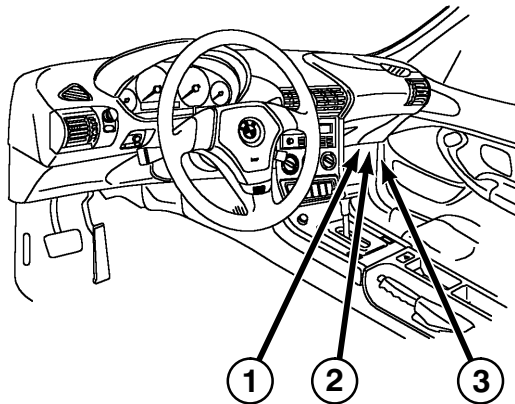

1

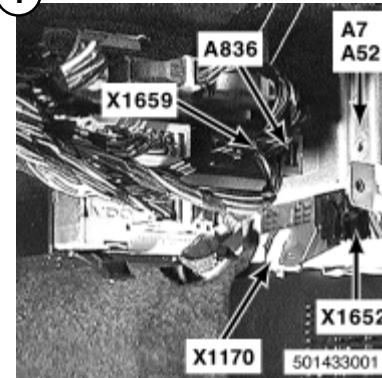

A7
SLIP CONTROL
MODULE (ABS) X1170
 X1652
 X1659

A52
SLIP CONTROL
MODULE
(ABS/ASC)

A836
ELECTRONIC
IMMOBILIZER
CONTROL MODULE
(EWS II)

2

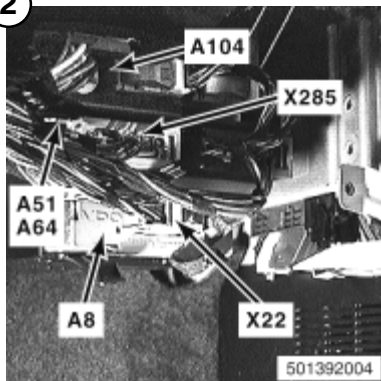

A8
CRUISE CONTROL
MODULE
(TEMPOMAT)

A51
WIPER/WASHER
MODULE

A64
WIPER/WASHER
MODULE (LOW II)

A104
BODY
ELECTRONICS
CONTROL MODULE
(ZKE IV)

X22
X285

3

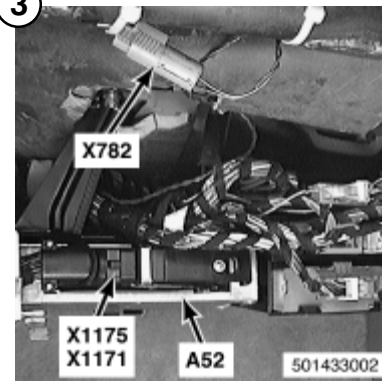

A52
SLIP CONTROL
MODULE
(ABS/ASC)

X782
X1171
X1175



COMPONENT LOCATION VIEWS

ELECTRICAL CONTROL MODULE LOCATIONS

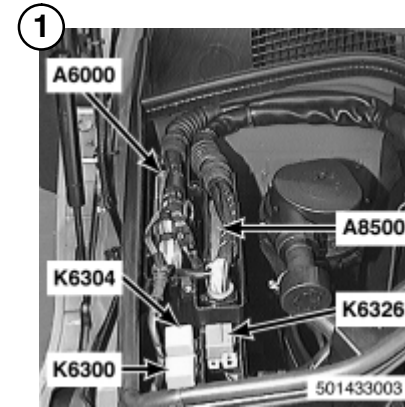
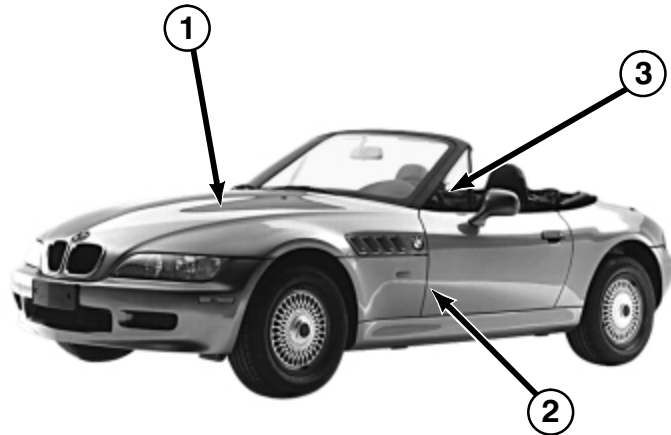

- A6000 ENGINE CONTROL MODULE (DME)
- K6304 SECONDARY AIR PUMP RELAY
- A8500 TRANSMISSION CONTROL MODULE (EGS)
- K6326 UNLOADER RELAY, TERMINAL 15
- K6300 ENGINE CONTROL MODULE RELAY

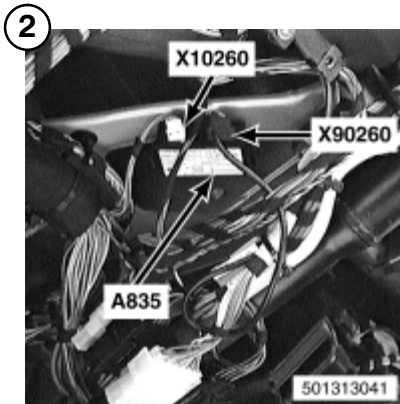

A835 TRANSMITTER MODULE (EWS II)

X10260
X90260

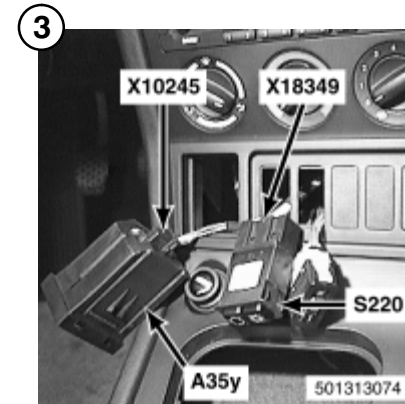

A35y BOARD COMPUTER (BC - LOW)

S220 AIR CONDITIONING/ RECIRCULATING SWITCH ASSEMBLY

X10245
X18349



COMPONENT LOCATION VIEWS

Z3

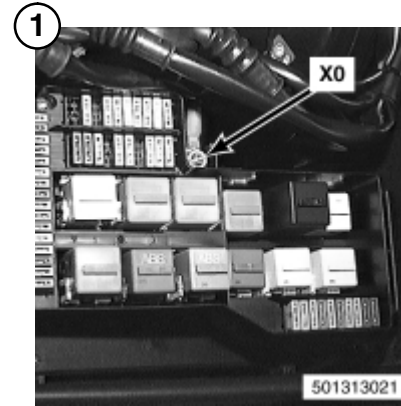
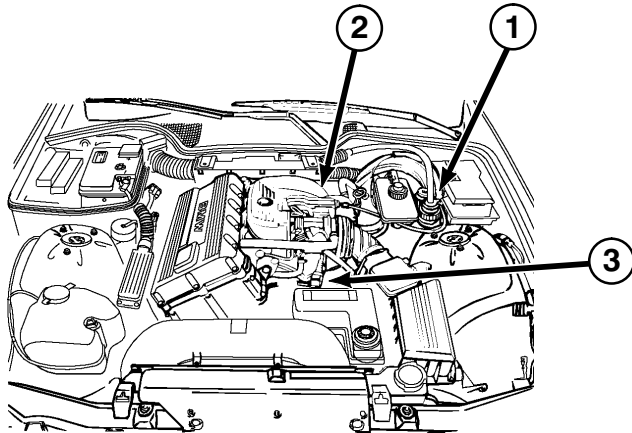
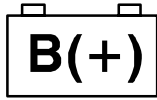

X0
B+ JUNCTION
POINT

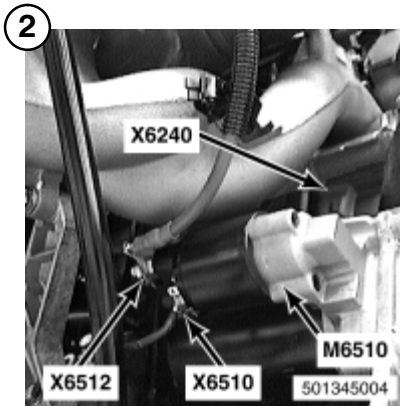

M6510
STARTER

- X6240
- X6510
- X6512

X6512 X6510 501345004

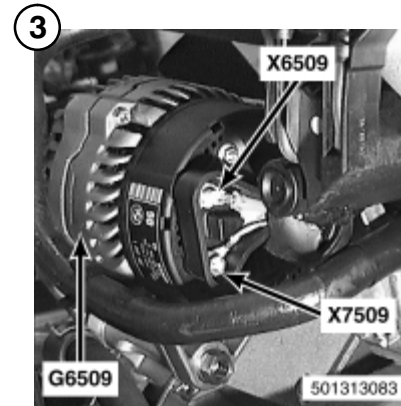

G6509
GENERATOR

- X6509
- X7509

G6509 X6509 X7509 501313083



Z3

COMPONENT LOCATION VIEWS

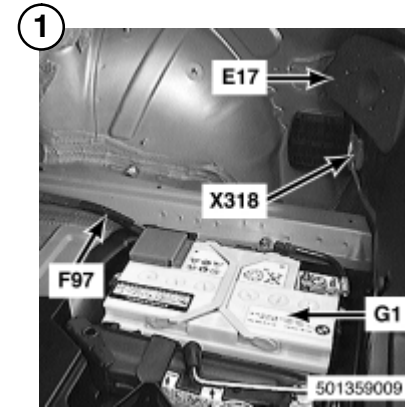
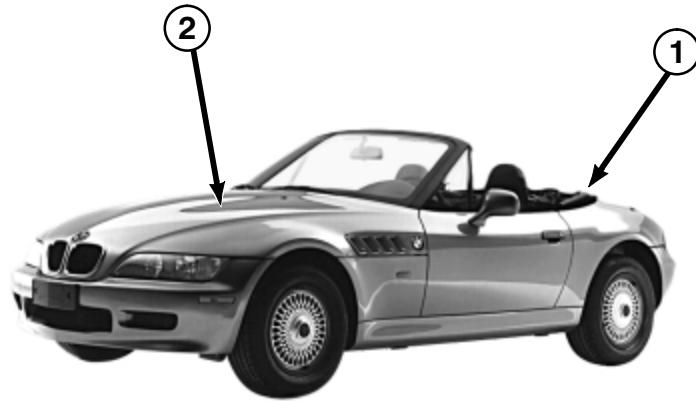
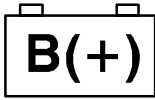

E17
RIGHT REAR LIGHT
ASSEMBLY

X318

F97
FUSIBLE LINK

G1
BATTERY



G6430
B+ JUMP START
JUNCTION POINT



COMPONENT LOCATION VIEWS

Z3

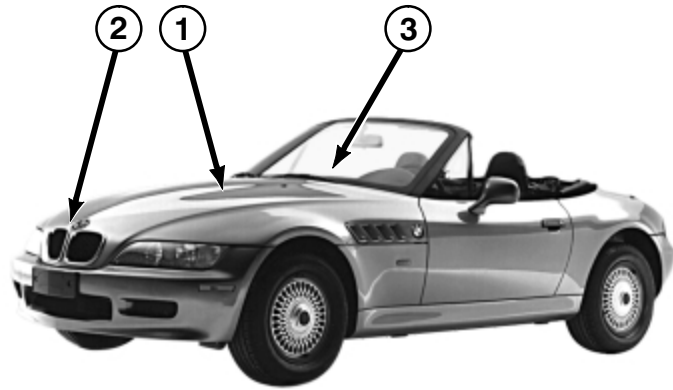
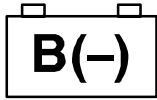

X6454
GROUND

X6456
GROUND

501313025

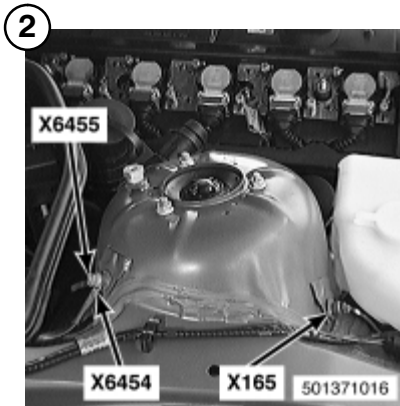

X165
GROUND

X6454
GROUND

X6455
GROUND

X6454

X165

501371016

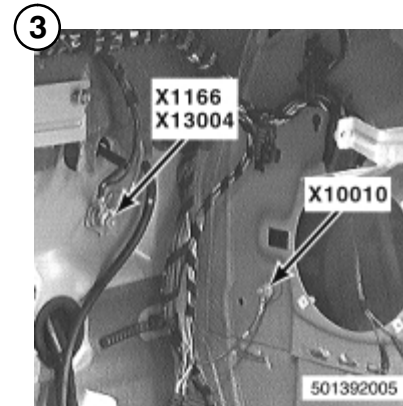

X1166
GROUND

X10010
GROUND

X13004
GROUND

X1166
X13004

X10010

501392005



COMPONENT LOCATION VIEWS

Z3

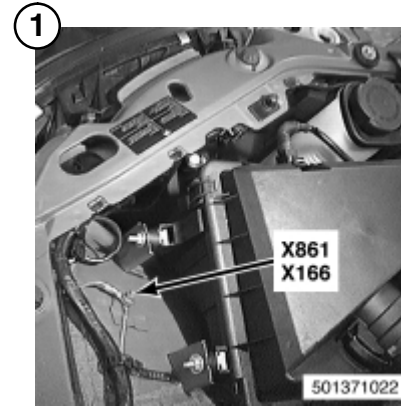
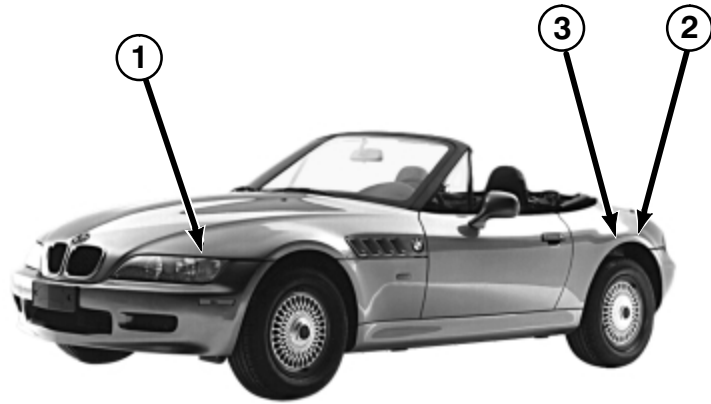
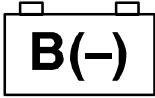

X166
GROUND

X861
GROUND

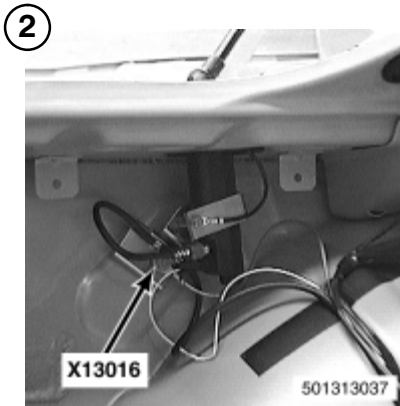

X13016
GROUND

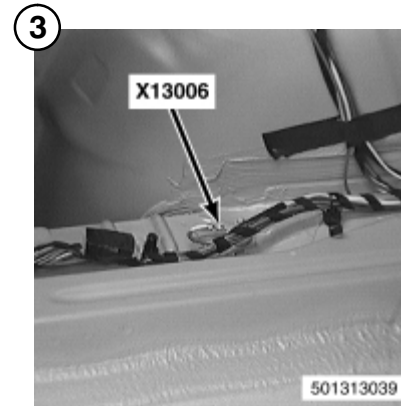

X13006
GROUND



3

Z3

COMPONENT LOCATION VIEWS

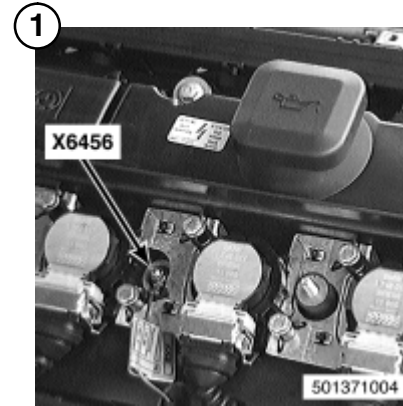
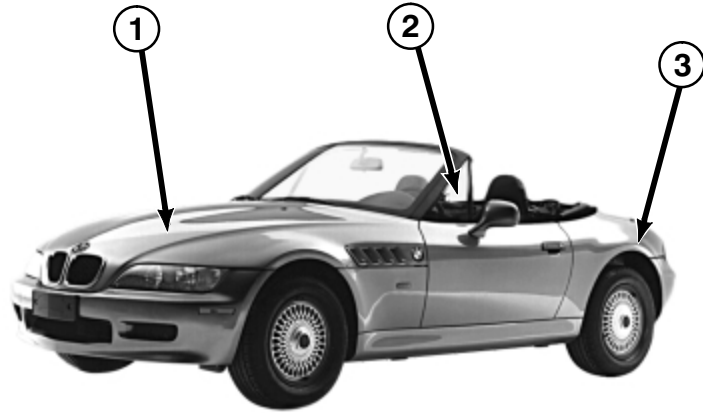
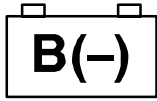

X13032
GROUND

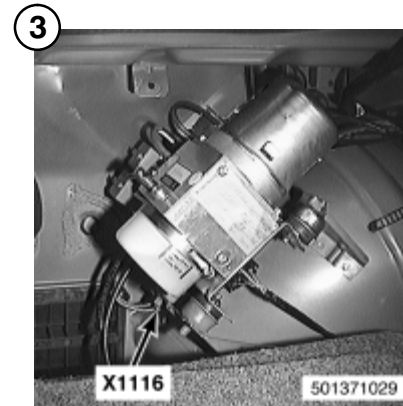

X1116
GROUND



COMPONENT LOCATION VIEWS

Z3

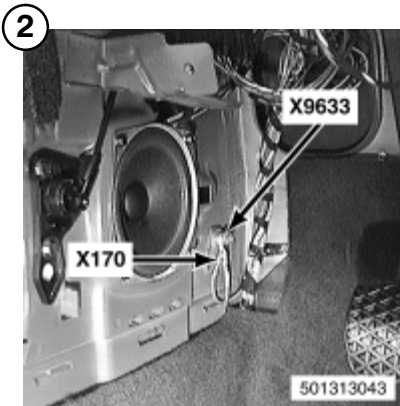
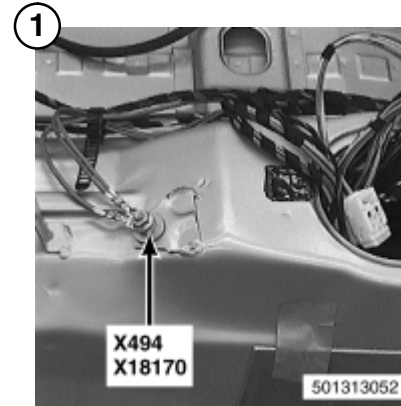
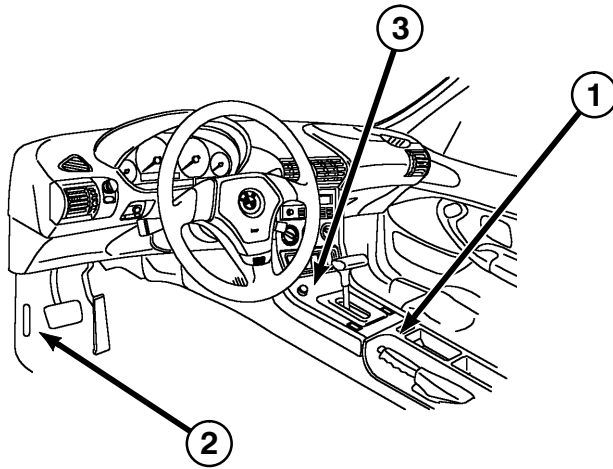
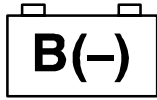

COMPONENT LOCATION VIEWS

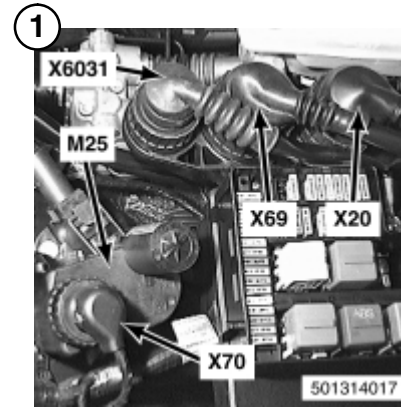
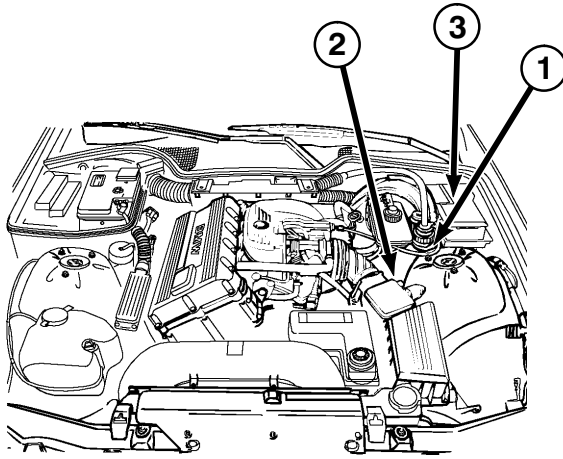

M25
CRUISE CONTROL
ACTUATOR
(TEMPOMAT)

X20
X69
X70
X6031



Y1w
ABS HYDRAULIC
UNIT

Y6120
EVAPORATIVE
EMISSION VALVE

X6120

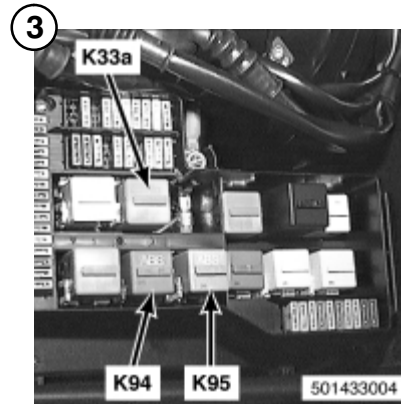

K33a
AIR CONDITIONING
RELAY, MOTRONIC

K94
ENGINE CONTROL
RELAY (ABS/ASC)

K95
VALVE RELAY
(ABS/ASC)

COMPONENT LOCATION VIEWS

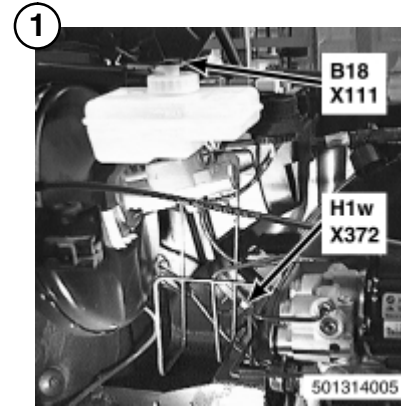
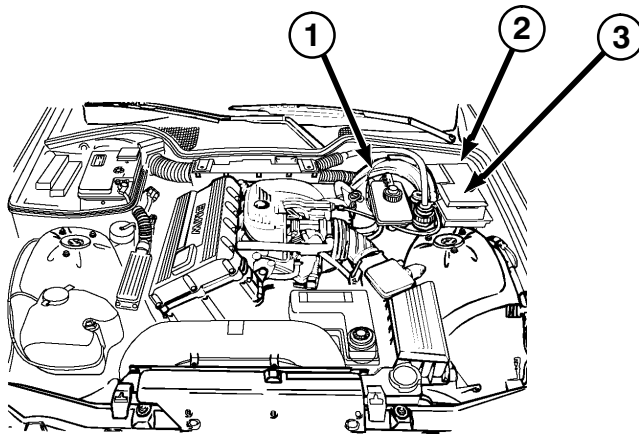

B18
BRAKE FLUID
LEVEL SWITCH

H1w
ANTI-THEFT HORN
(ALPINE)

X111
X372

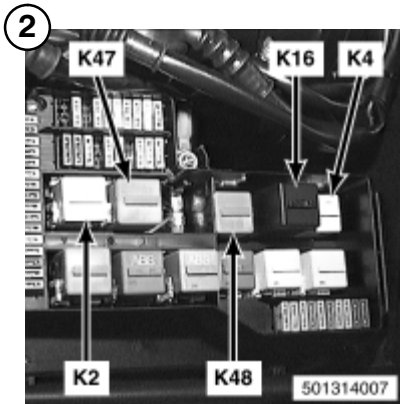

K2
HORN RELAY

K47
FRONT FOG LIGHT
RELAY

K4
BLOWER RELAY

K48
LOW BEAM LIGHT
RELAY

K16
HAZARD FLASHER
RELAY

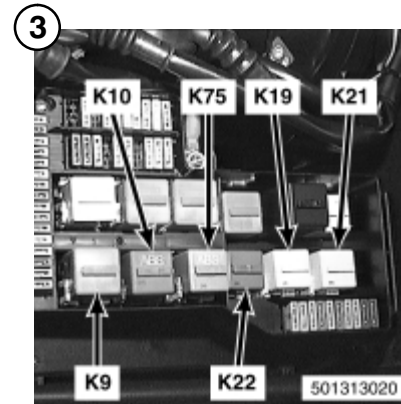

K9
UNLOADER RELAY,
TERMINAL 15

K21
NORMAL SPEED
RELAY

K10
ABS RELAY

K22
HIGH SPEED
RELAY

K19
COMPRESSOR
CONTROL RELAY

K75
ABS PUMP MOTOR
RELAY

COMPONENT LOCATION VIEWS

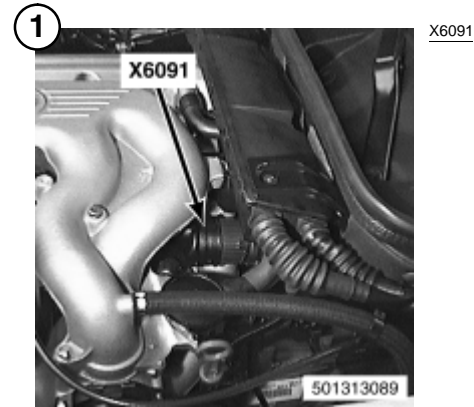
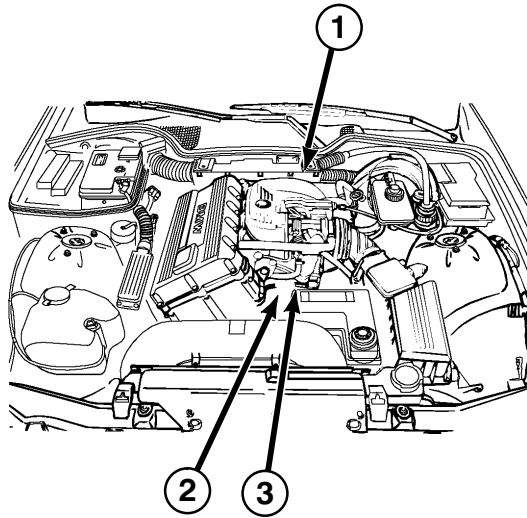

X6091

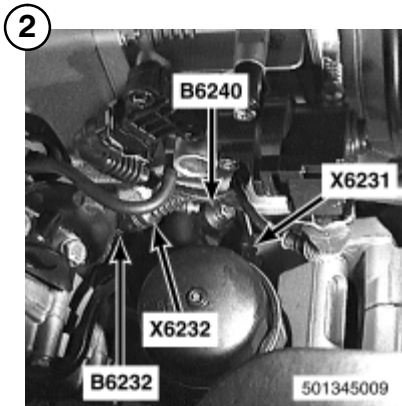

B6232
ENGINE COOLANT
TEMPERATURE
SENSOR

B6240
KNOCK SENSOR

X6231
X6232

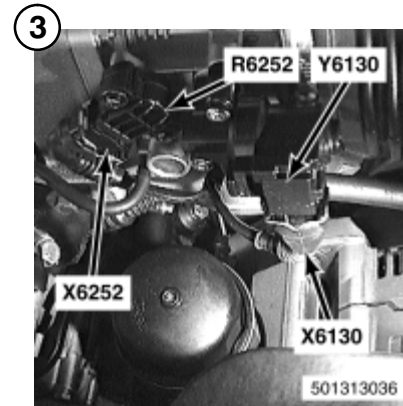

R6252
THROTTLE
POSITION SENSOR

Y6130
IDLE SPEED
CONTROL VALVE

X6130
X6252

COMPONENT LOCATION VIEWS

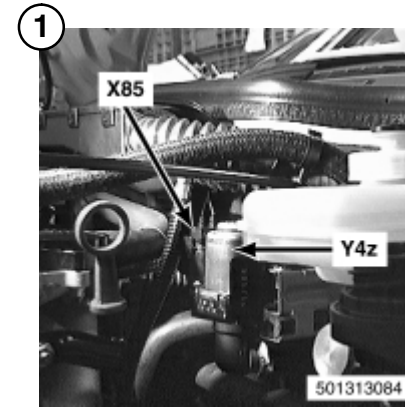
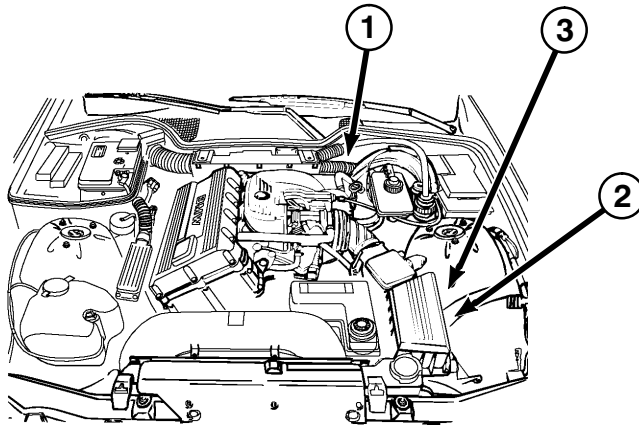

Y4z
WATER VALVE

X85

501313084

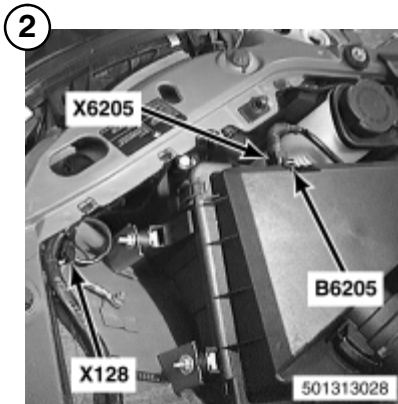

B6205
INTAKE AIR
TEMPERATURE
SENSOR

X128
X6205

B6205

X128

501313028

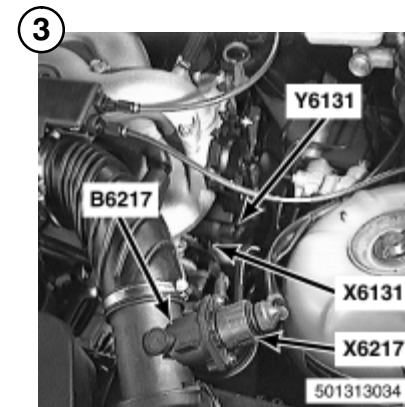

B6217
HOT FILM AIR
MASS METER

Y6131
INTAKE AIR RES-
ONANCE CHANGE-
OVER VALVE

X6131
X6217

501313034

COMPONENT LOCATION VIEWS

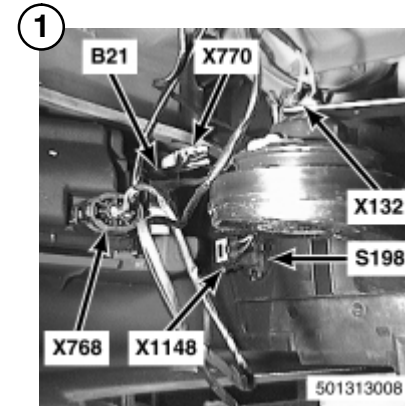
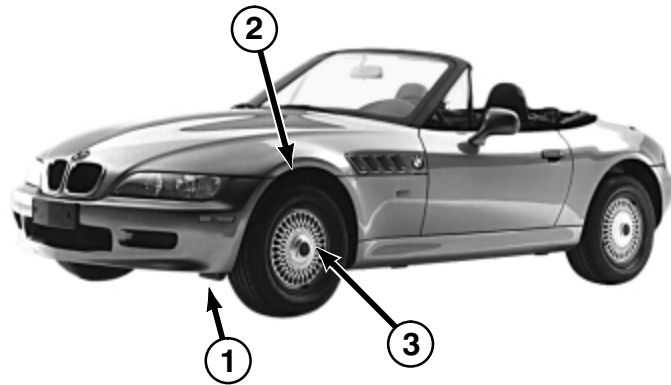

- B21
ON-BOARD
COMPUTER
TEMPERATURE
SENSOR
- S198
JET HEATER
THERMOSWITCH
- X132
- X768
- X770
- X1148

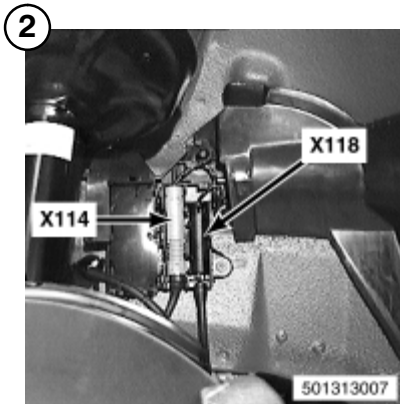

- X114
- X118

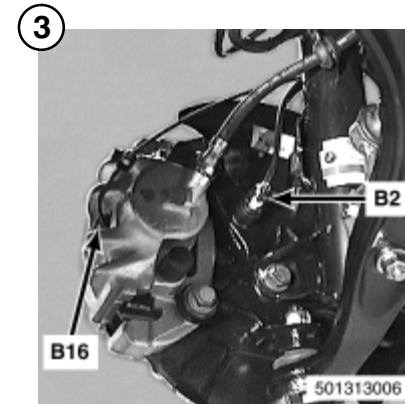

- B2
LEFT FRONT
SPEED SENSOR –
ABS
- B16
LEFT FRONT
BRAKE PAD
SENSOR

COMPONENT LOCATION VIEWS

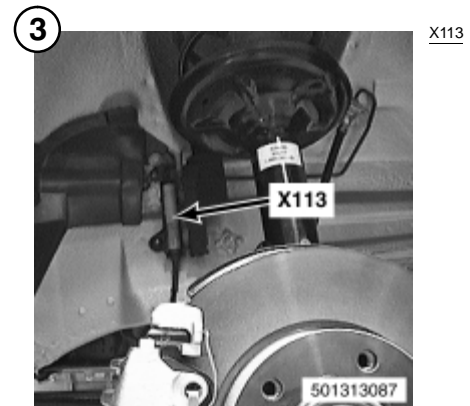
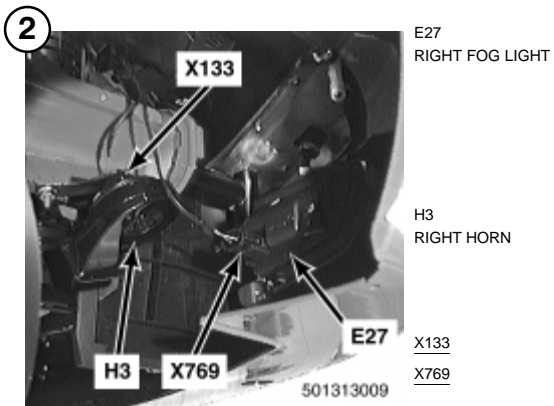
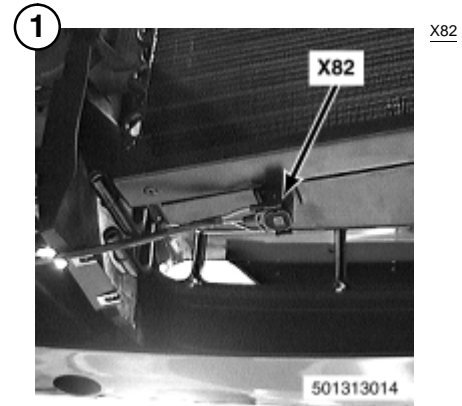
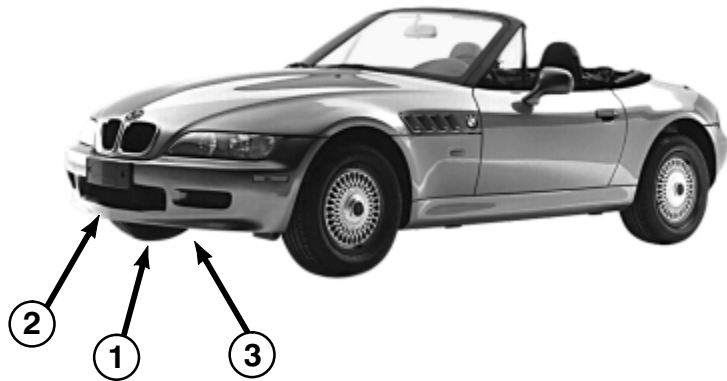

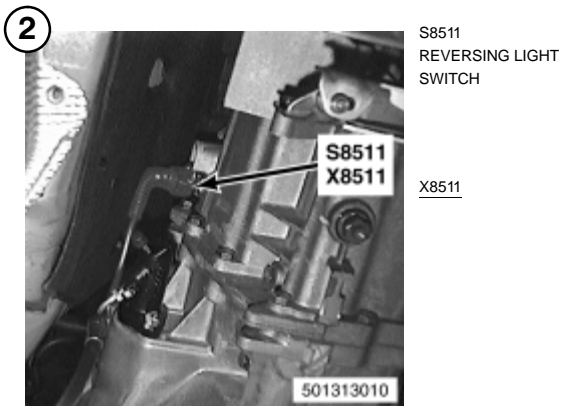
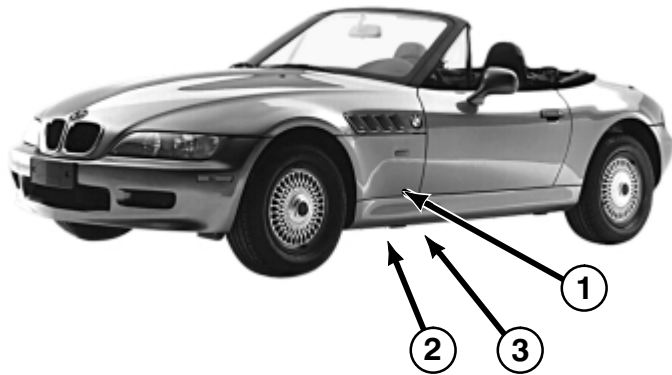

COMPONENT LOCATION VIEWS

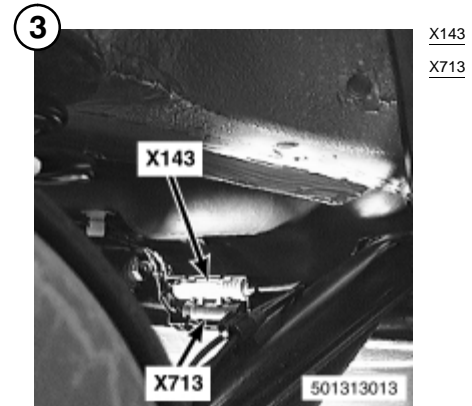
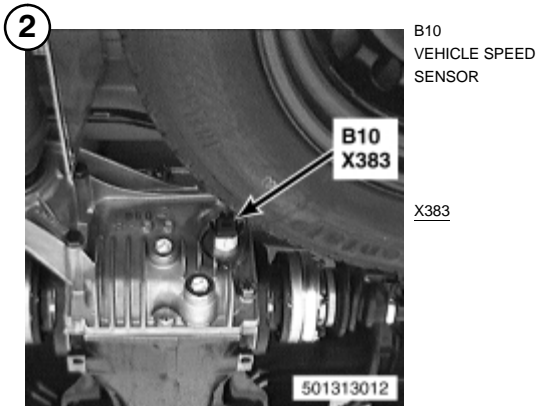
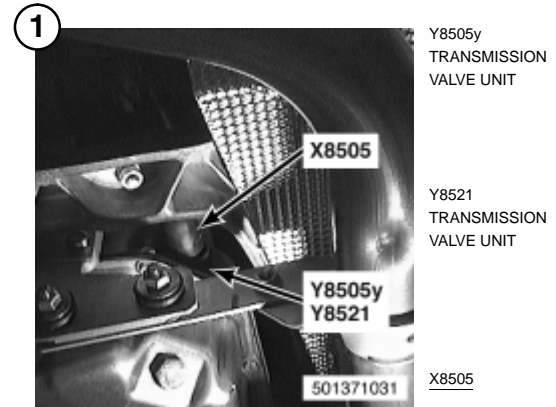
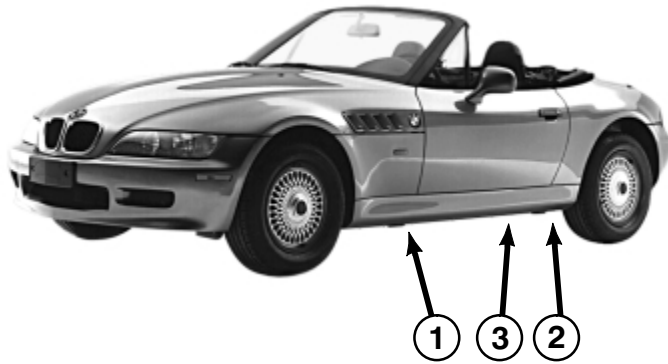

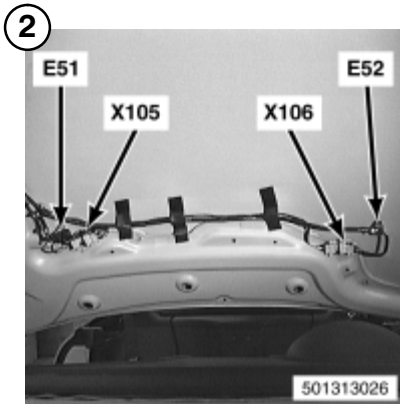
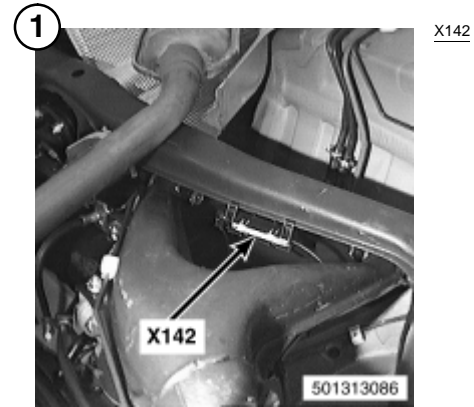
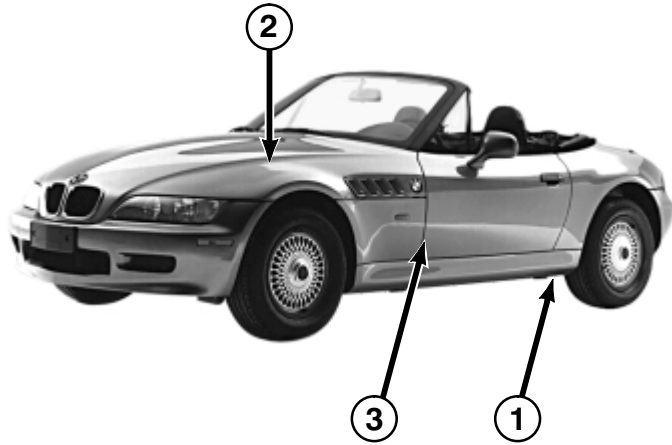

E51
LEFT WASHER JET
HEATER

E52
RIGHT WASHER
JET HEATER

X105
X106

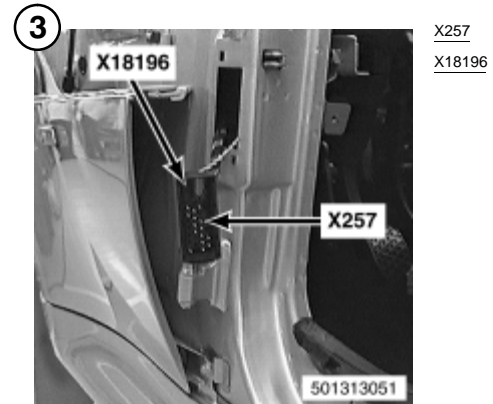

X257
X18196

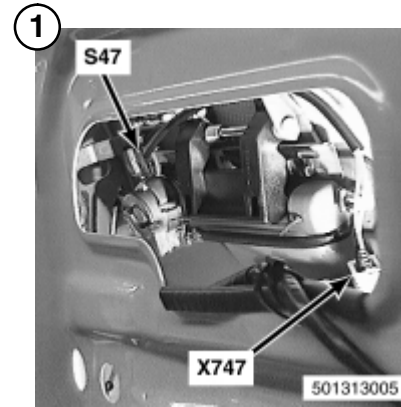
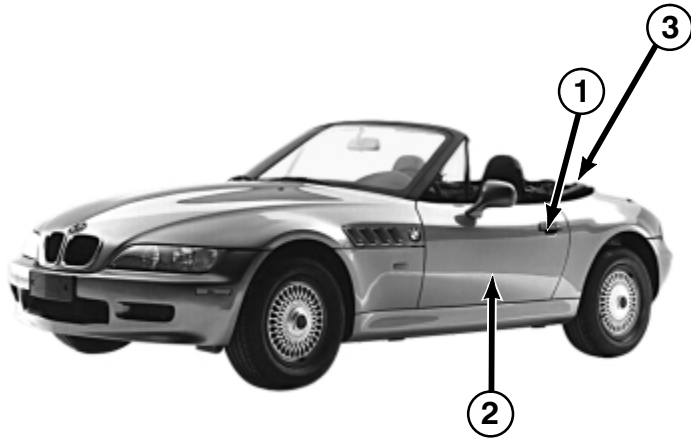

S47
DRIVER'S DOOR
LOCK SWITCH

X747

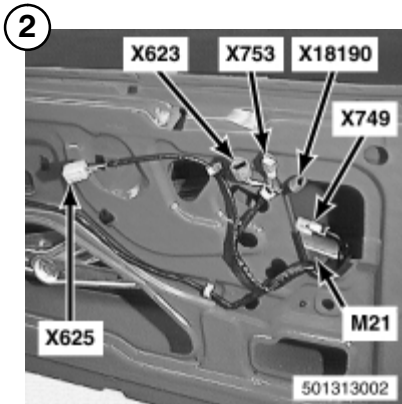

M21
DRIVER'S WINDOW
MOTOR

X623
X625
X749
X753
X18190

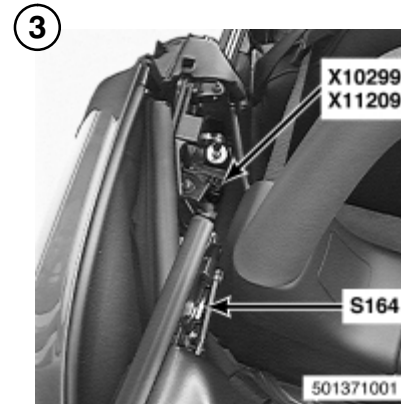

S164
CONVERTIBLE TOP
END-POSITION
MICRO SWITCH

X10299
X11209

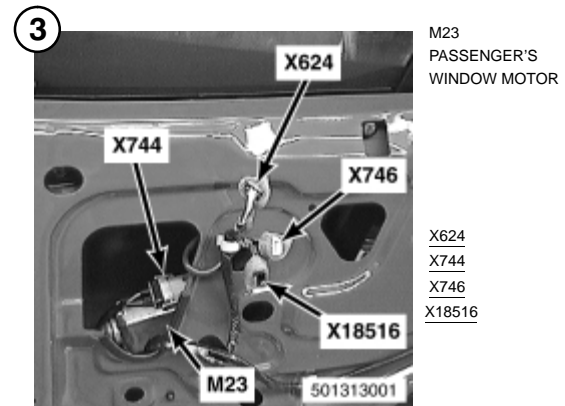
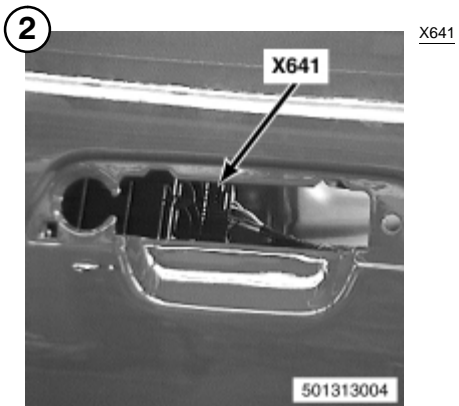
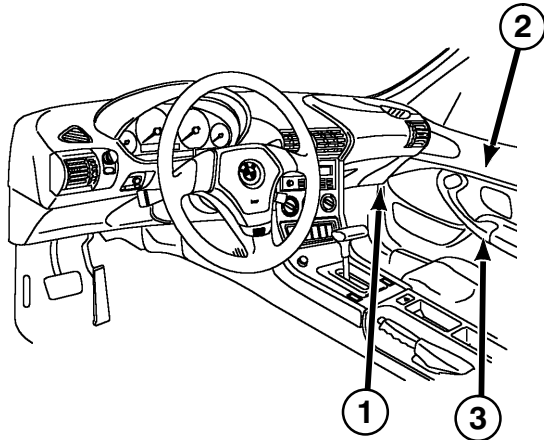

COMPONENT LOCATION VIEWS

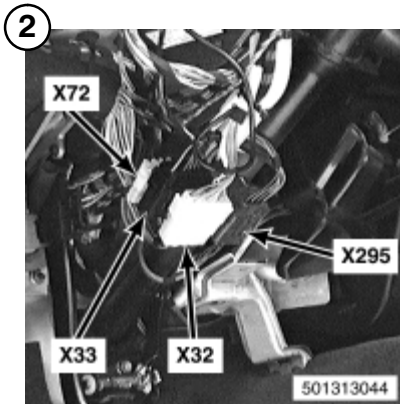
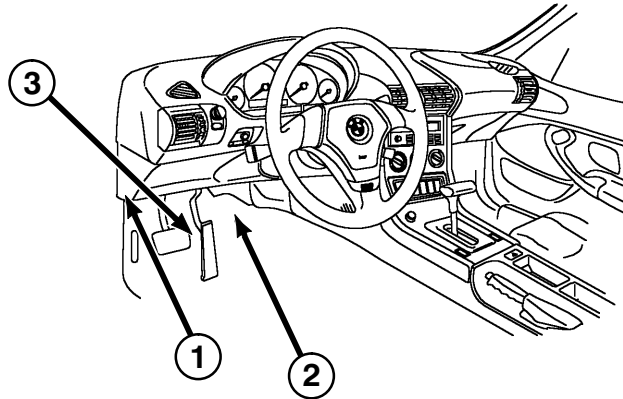

X32
X33
X72
X295

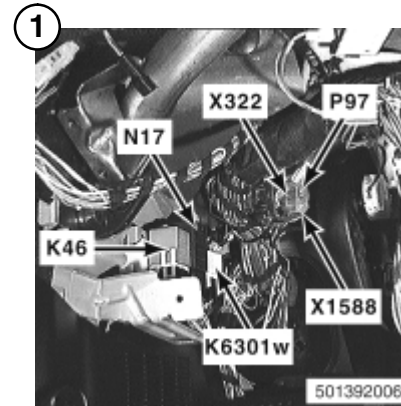

K46 HIGH BEAM LIGHT RELAY	P97 AUXILIARY FUSE BOX
K6301w FUEL PUMP RELAY	X322 X1588
N17 CRASH CONTROL MODULE	

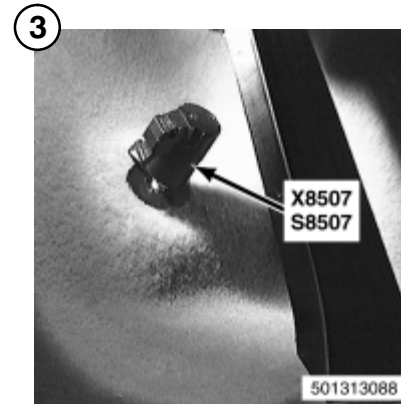

S8507
KICK-DOWN
SWITCH

X8507

COMPONENT LOCATION VIEWS

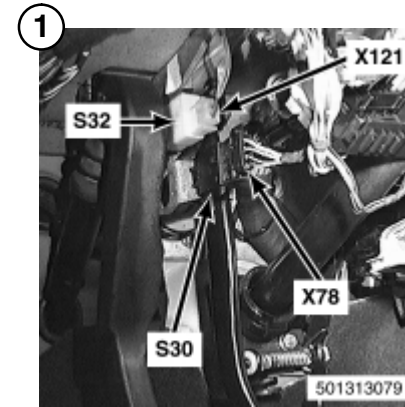
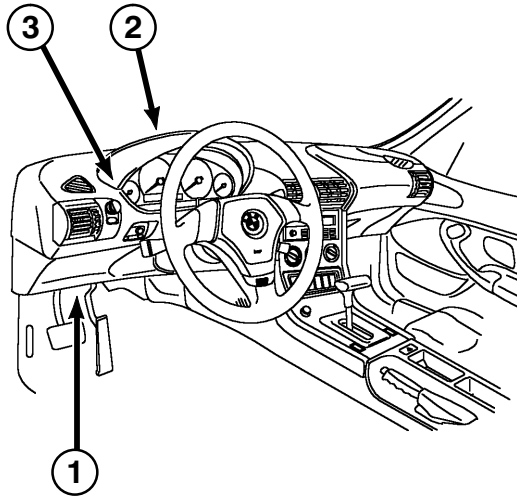

S30
BRAKE LIGHT
SWITCH

S32
CLUTCH SWITCH

X78
X121

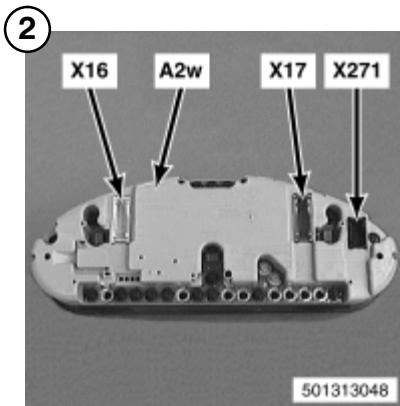

A2w
INSTRUMENT
CLUSTER

X16
X17
X271

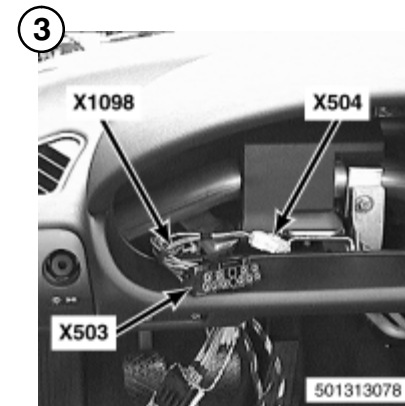

X503
X504
X1098

COMPONENT LOCATION VIEWS

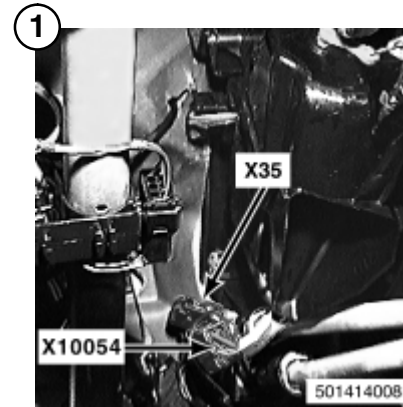
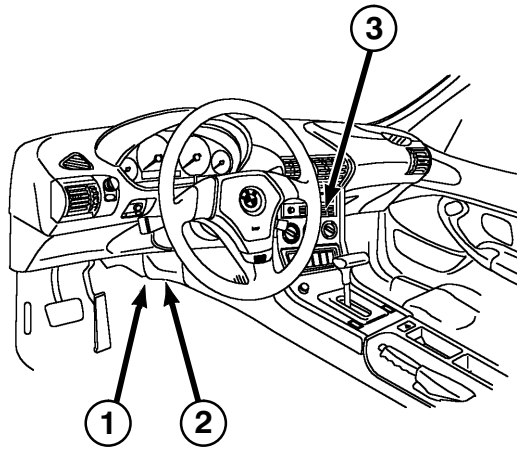

X35
X10054

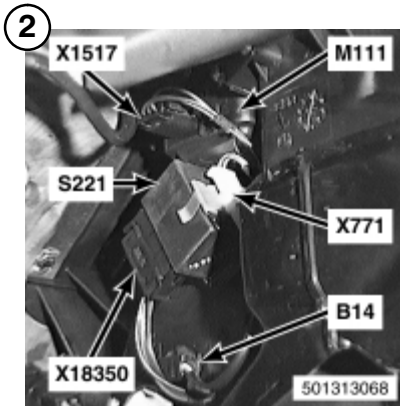

B14
EVAPORATOR
TEMPERATURE
SENSOR

X771
X1517
X18350

M111
FRESH AIR
RECIRCULATION
MOTOR

S221
EVAPORATOR
CONTROLLER

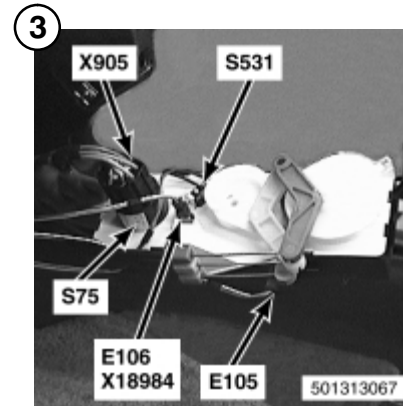

E105
HEAT/A/C
CONTROL PANEL
ILLUMINATION

S531
TEMPERATURE
WHEEL SWITCH

E106
HEAT/A/C
CONTROL PANEL
ILLUMINATION

X905
X18984

S75
BLOWER SWITCH

COMPONENT LOCATION VIEWS

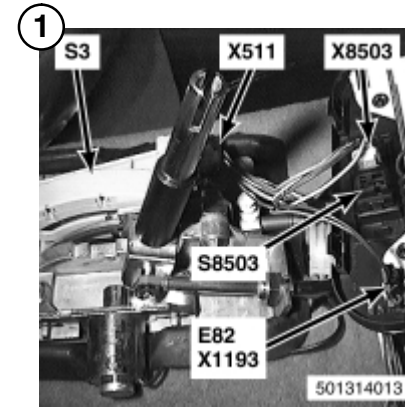
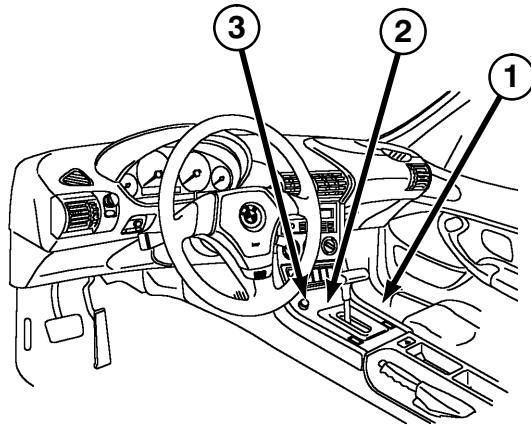

E82
TRANSMISSION
POSITION INDICA-
TOR LIGHT

X511
X1193
X8503

S3
AUTOMATIC
TRANSMISSION
RANGE SWITCH

S8503
PROGRAM SWITCH

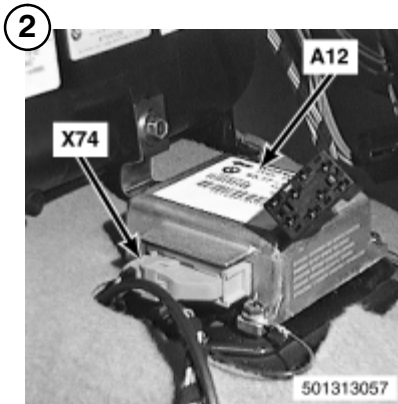

A12
SUPPLEMENTAL
RESTRAINT
SYSTEM CONTROL
MODULE

X74

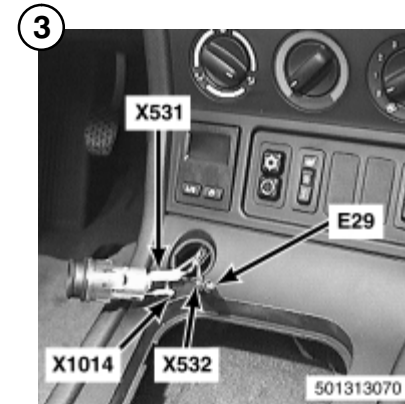

E29
FRONT CIGAR
LIGHTER LIGHT

X531
X532
X1014

COMPONENT LOCATION VIEWS

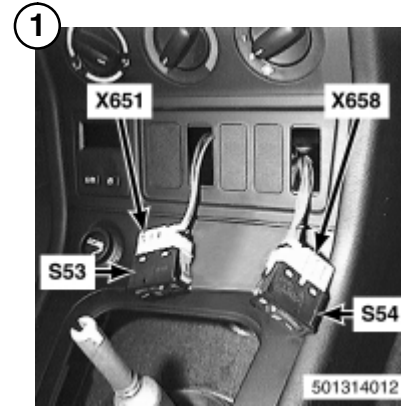
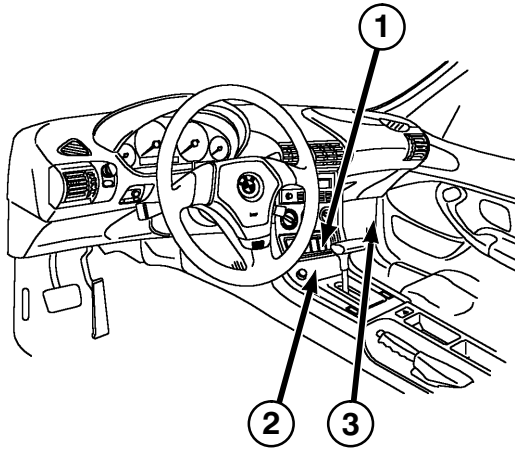

S53
DRIVER'S SEAT,
SEAT HEATER
SWITCH

S54
PASSENGER'S
SEAT, SEAT
HEATER SWITCH

X651
X658

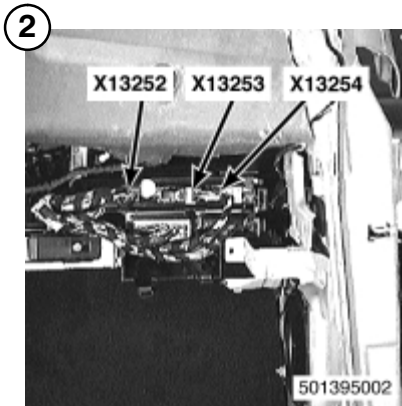

X13252
X13253
X13254

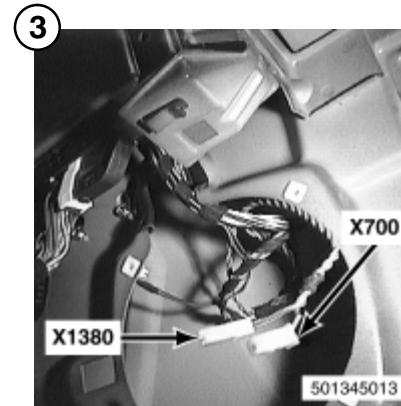

X700
X1380

COMPONENT LOCATION VIEWS

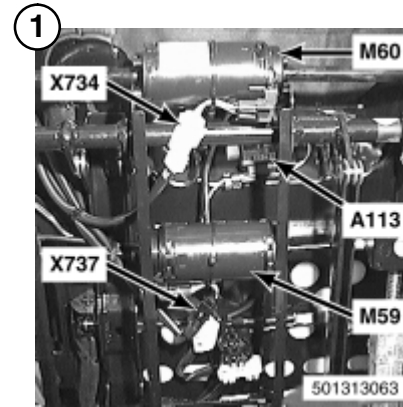
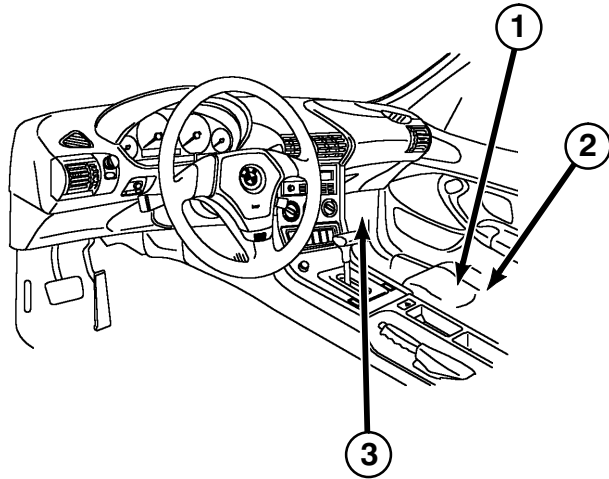

A113 SEAT OCCUPANCY DETECTOR X734
X737

M59 PASSENGER'S SEAT HEIGHT MOTOR

M60 PASSENGER'S SEAT MOVEMENT MOTOR

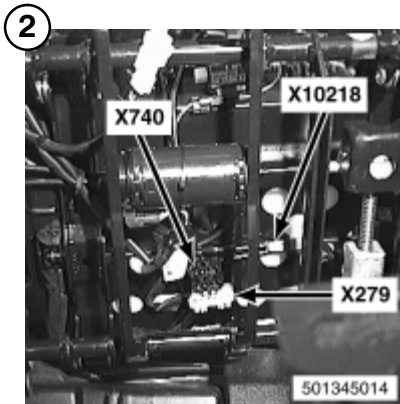

X279
X740
X10218

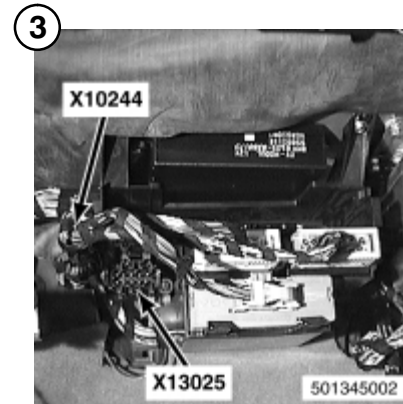

X10244
X13025

COMPONENT LOCATION VIEWS

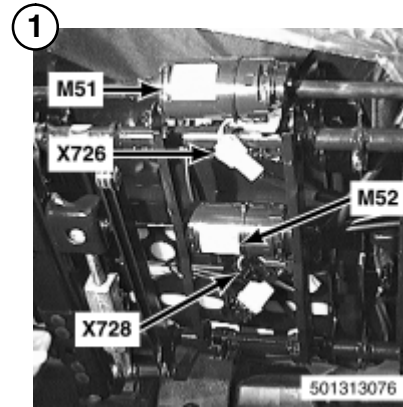
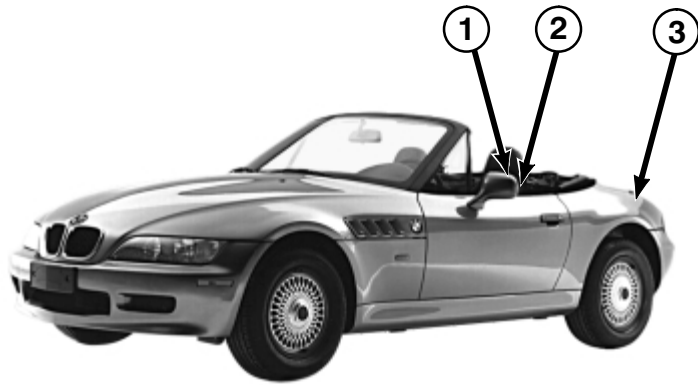

M51
DRIVER'S SEAT
MOVEMENT
MOTOR

M52
DRIVER'S SEAT
HEIGHT MOTOR

X726
X728

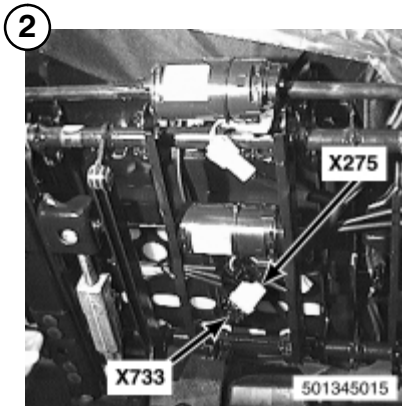

X275
X733

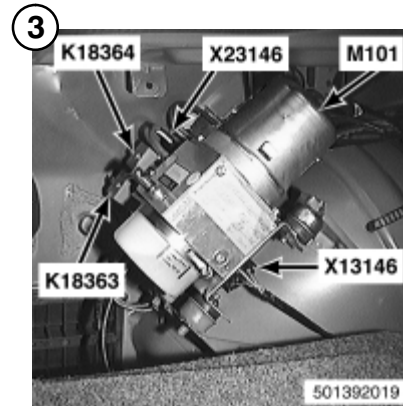

K18363
CONVERTIBLE TOP
RELAY I (CLOSE)

X13146
X23146

K18364
CONVERTIBLE TOP
RELAY II (OPEN)

M101
CONVERTIBLE TOP
MOTOR

COMPONENT LOCATION VIEWS

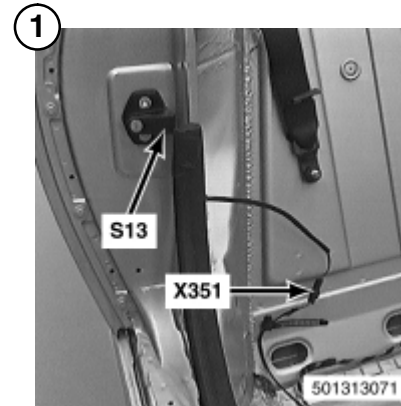
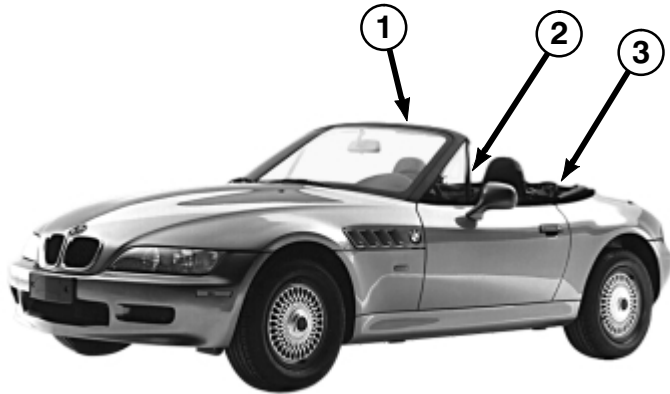

S13
PASSENGER'S
DOOR JAMB
SWITCH

X351

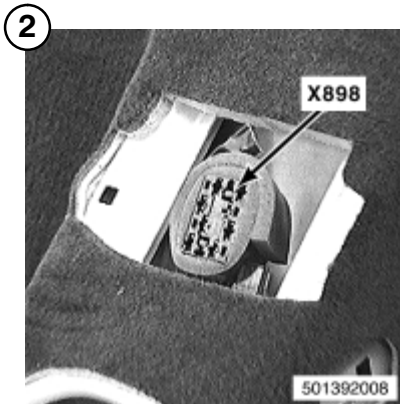

X898



X10246
X18774

COMPONENT LOCATION VIEWS

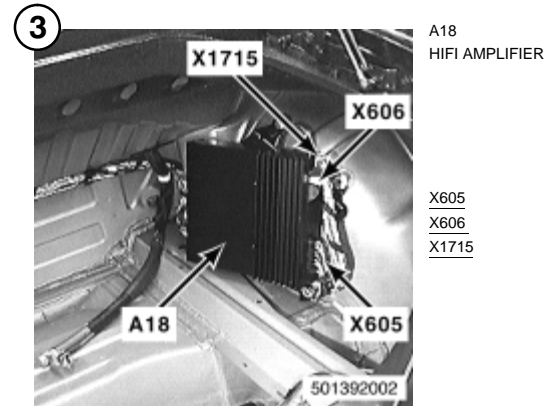
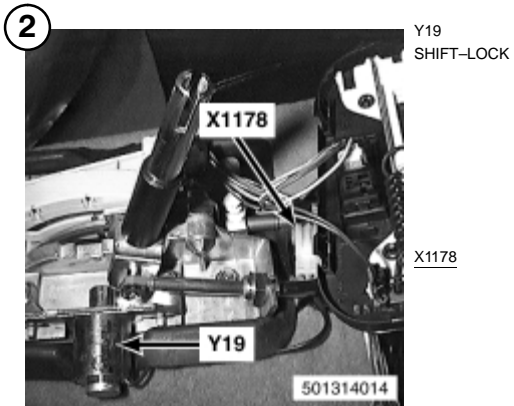
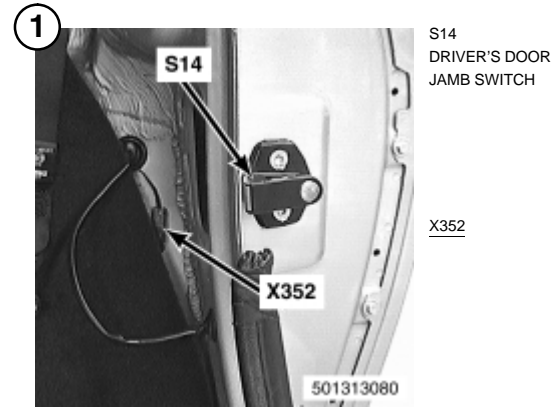
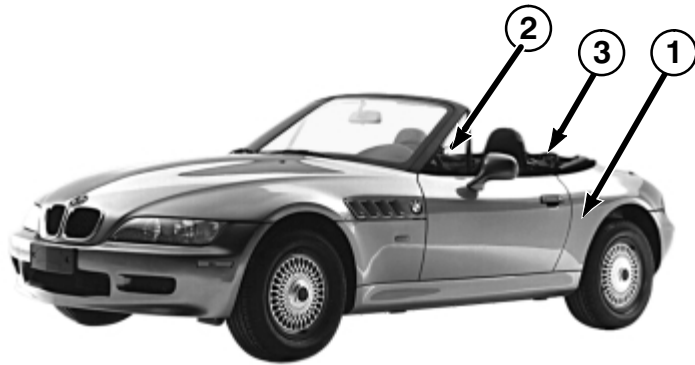

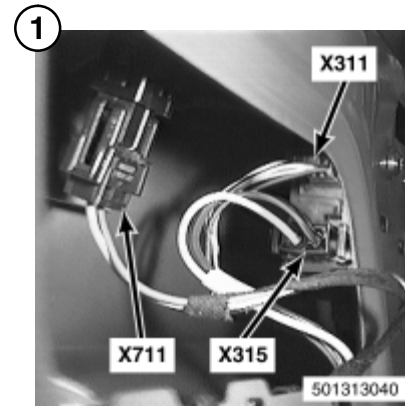
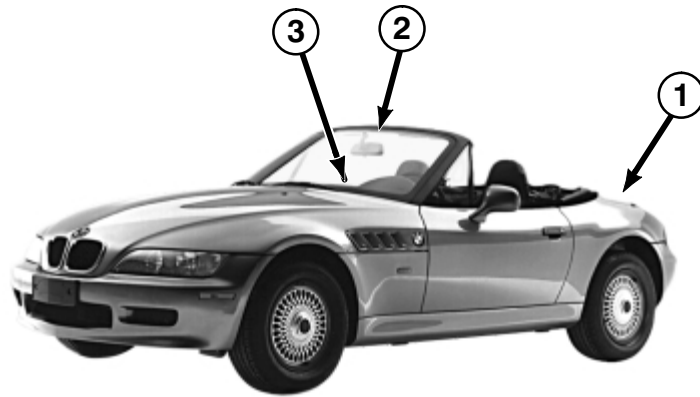

X311
X315
X711

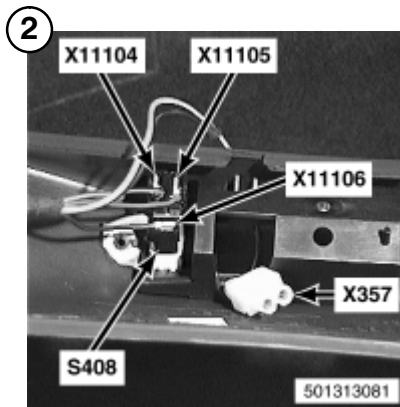

S408
INTERIOR LIGHT
SWITCH

X357
X11104
X11105
X11106



D110
OBD II
CONNECTOR

X19527

COMPONENT LOCATION VIEWS

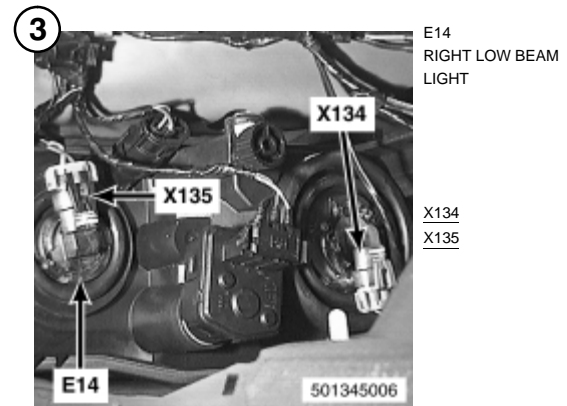
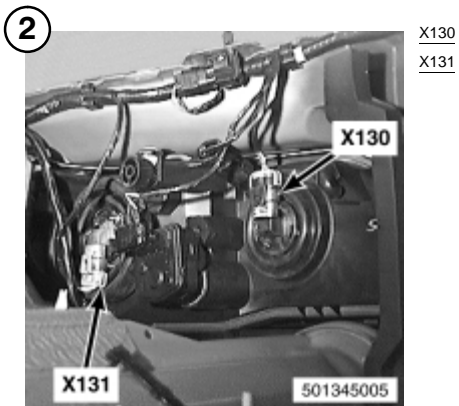
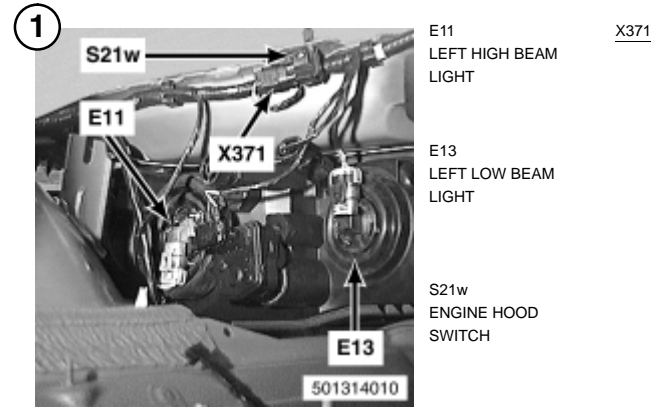
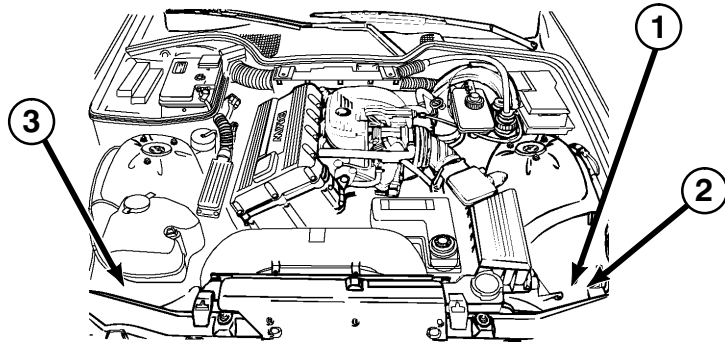

COMPONENT LOCATION VIEWS

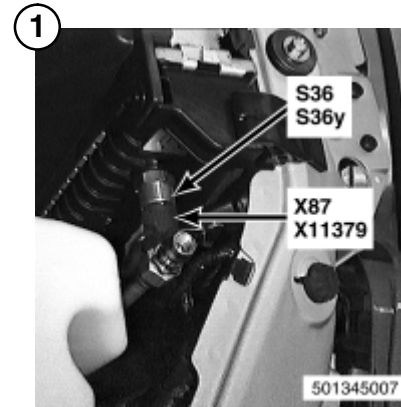
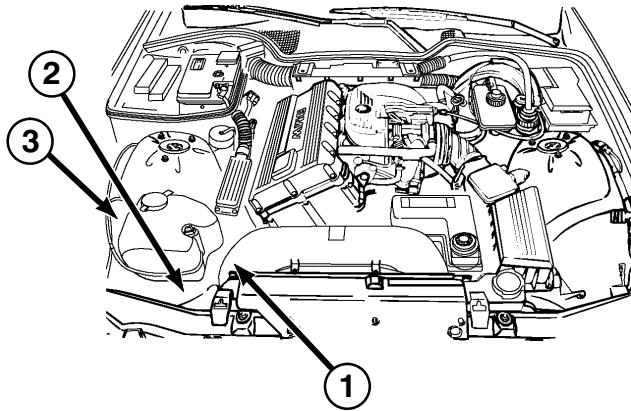

S36
TEMPERATURE
SWITCH

S36y
DOUBLE
TEMPERATURE
SWITCH

X87
X11379

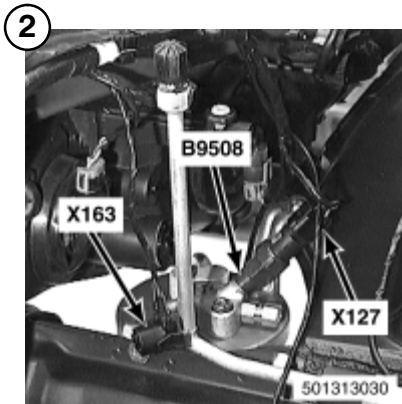

B9508
PRESSURE
SWITCH

X127
X163

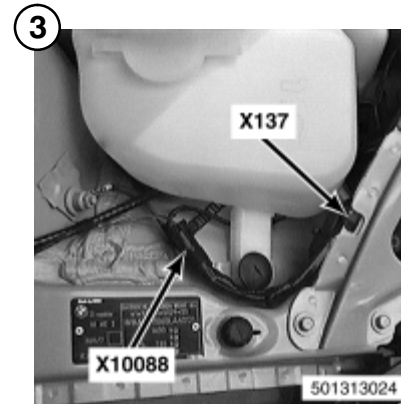

X137
X10088

COMPONENT LOCATION VIEWS

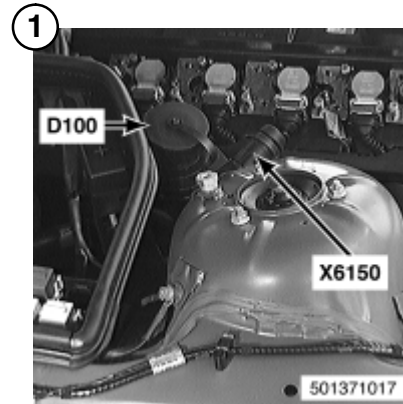
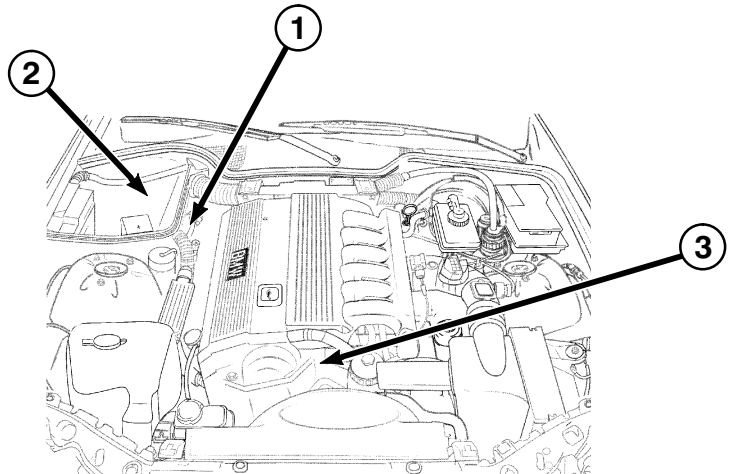

D100
DATA LINK
CONNECTOR

X6150

X6150

501371017



Y6133
AIR PUMP

X6133

X6133

501371003

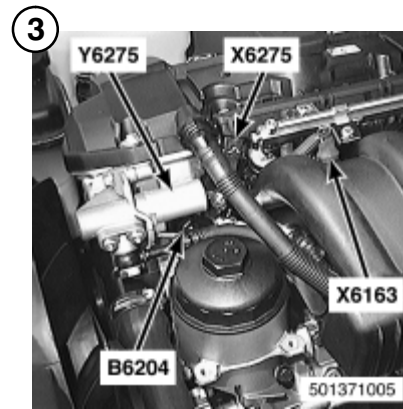

B6204
CAMSHAFT
POSITION SENSOR
(CYLINDER
IDENTIFICATION)

Y6275
VARIABLE CAM-
SHAFT CONTROL
VALVE 1

X6163
X6275

B6204

501371005

COMPONENT LOCATION VIEWS

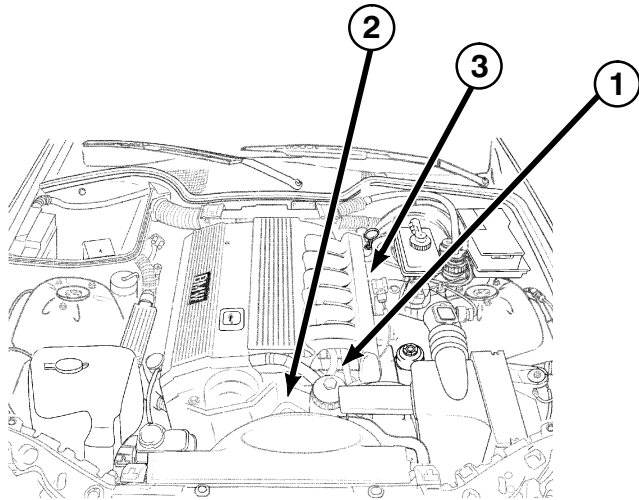

B6256
DUAL
TEMPERATURE
SENSOR
(COOLANT
TEMPERATURE)

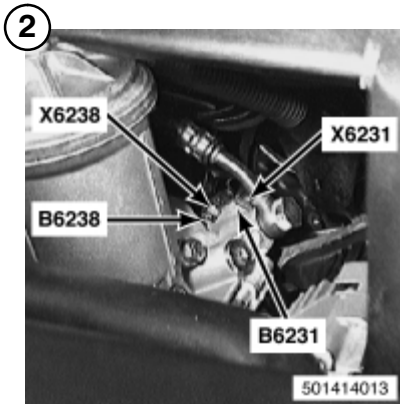

B6231
OIL PRESSURE
SWITCH

B6238
OIL TEMPERATURE
SENSOR

X6231
X6238

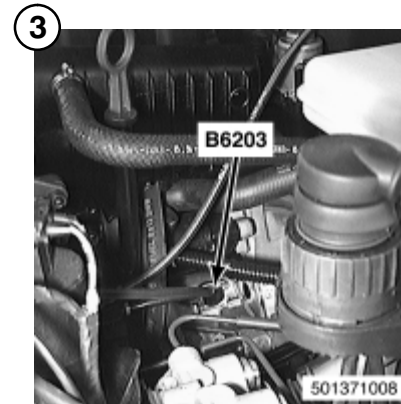

B6203
CRANKSHAFT
POSITION/RPM
SENSOR

COMPONENT LOCATION VIEWS

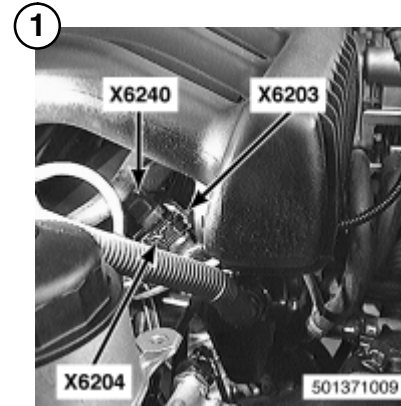
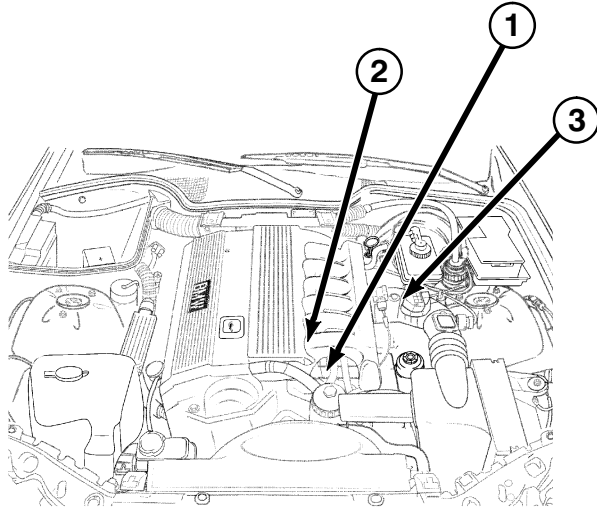

X6203
X6204
X6240



B6240
KNOCK SENSOR

Y6163
SECONDARY AIR
PUMP VALVE

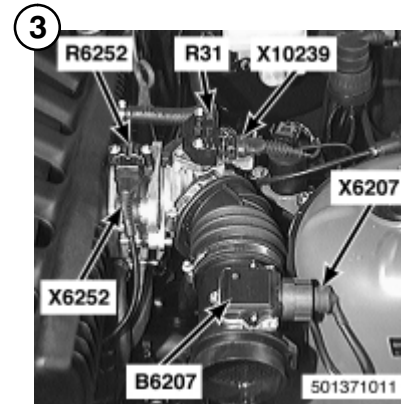

B6207
HOT FILM AIR
MASS METER

X6207
X6252
X10239

R31
AUXILIARY
THROTTLE
POSITION SENSOR

R6252
THROTTLE
POSITION SENSOR

COMPONENT LOCATION VIEWS

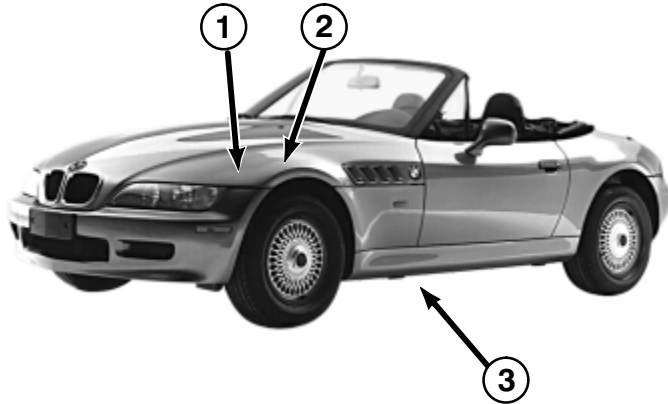

B6205
INTAKE AIR
TEMPERATURE
SENSOR

X6205



Y6120
EVAPORATIVE
EMISSION VALVE

X6120

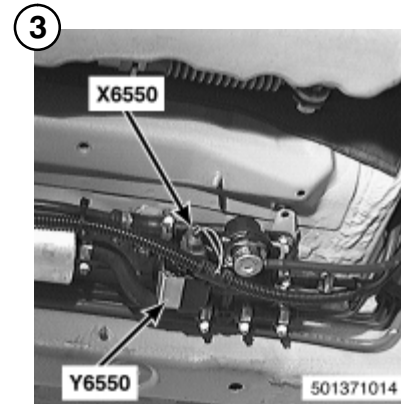

Y6550
SOLENOID VALVE
("RUNNING
LOSSES")

X6550

COMPONENT LOCATION VIEWS

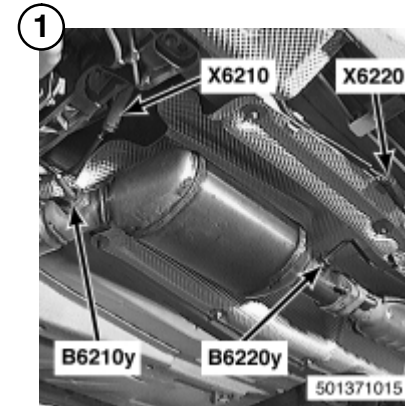
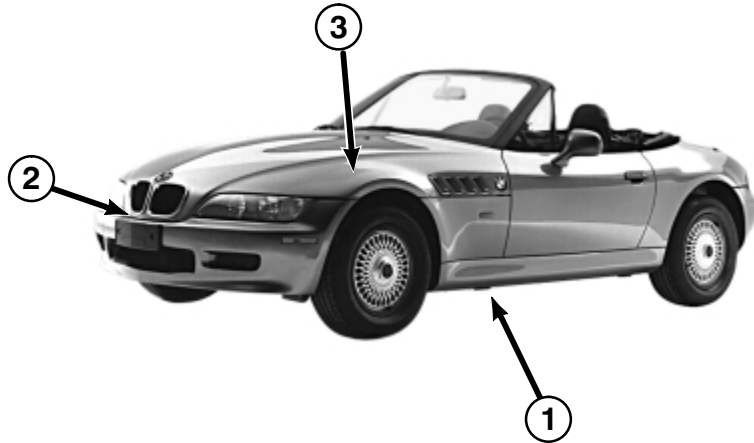

B6210y
OXYGEN SENSOR
(IN FRONT OF
CATALYTIC
CONVERTER)

B6220y
OXYGEN SENSOR
(BEHIND
CATALYTIC
CONVERTER)

X6210
X6220

501371015

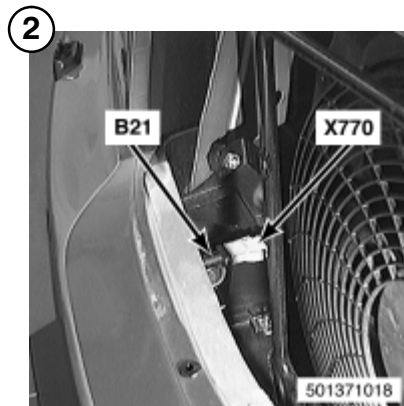

B21
ON-BOARD
COMPUTER
TEMPERATURE
SENSOR

X770

501371018

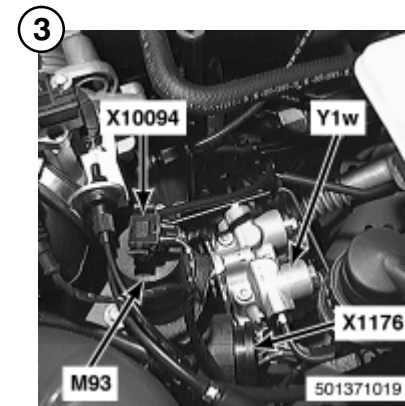

M93
AUXILIARY
THROTTLE
POSITION MOTOR
(ADS)

Y1w
ABS HYDRAULIC
UNIT

X1176
X10094

501371019

COMPONENT LOCATION VIEWS

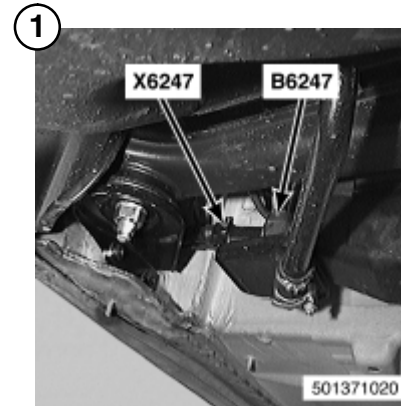
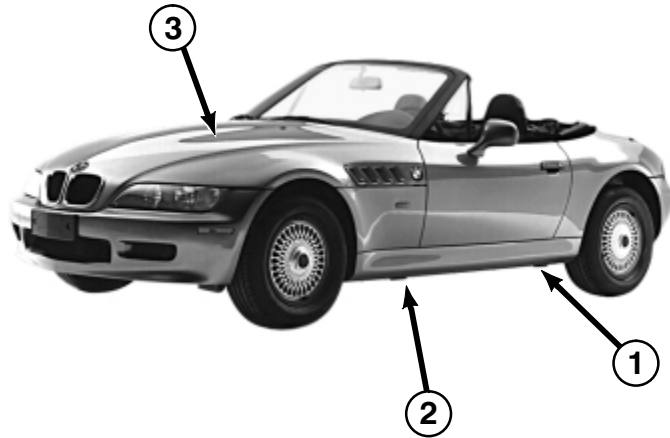

B6247
CHARCOAL FILTER
SHUT-OFF VALVE

X6247

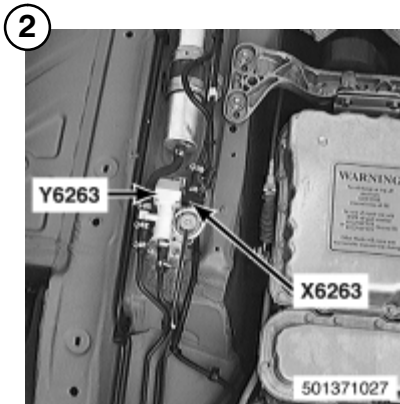

Y6263
FUEL CHANGE-
OVER VALVE

X6263

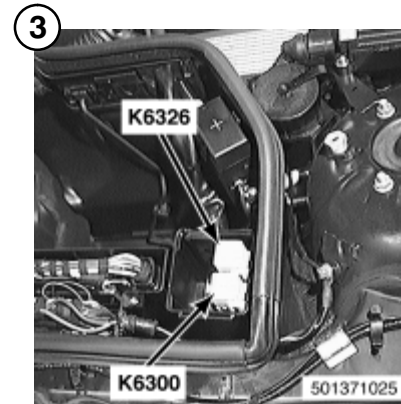

K6300
ENGINE CONTROL
MODULE RELAY

K6326
UNLOADER RELAY,
TERMINAL 15

COMPONENT LOCATION VIEWS

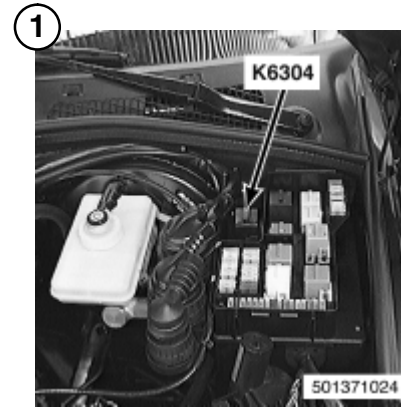
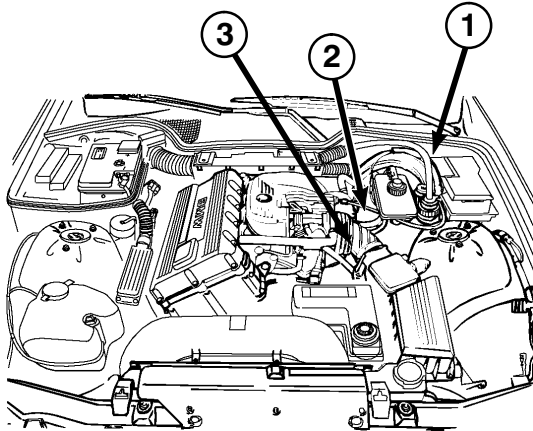

1
K6304
SECONDARY AIR
PUMP RELAY



2
Y6133
AIR PUMP

X6133

X6133

501371023

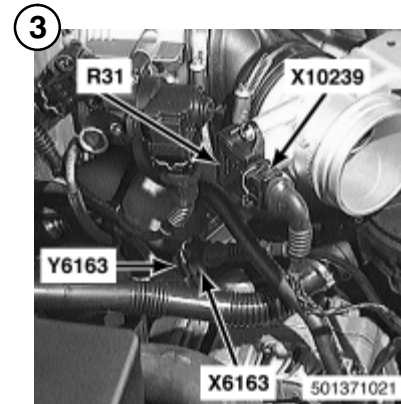

3
R31
AUXILIARY
THROTTLE
POSITION SENSOR

Y6163
SECONDARY AIR
PUMP VALVE

X6163
X10239

X6163 501371021

COMPONENT LOCATION VIEWS

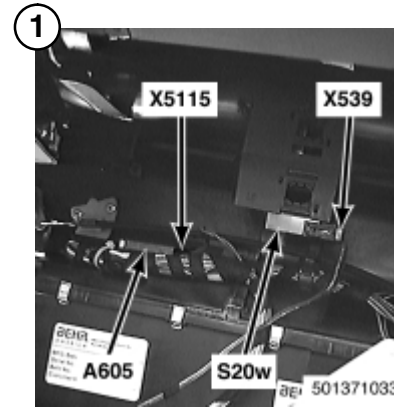
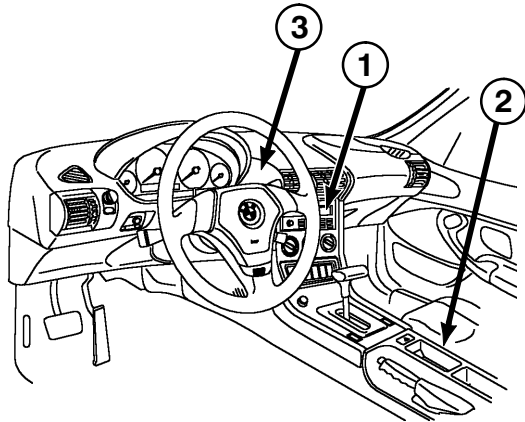

A605
FUSE HOLDER

S20w
RADIO ANTI-
THEFT SWITCH

X539
X5115

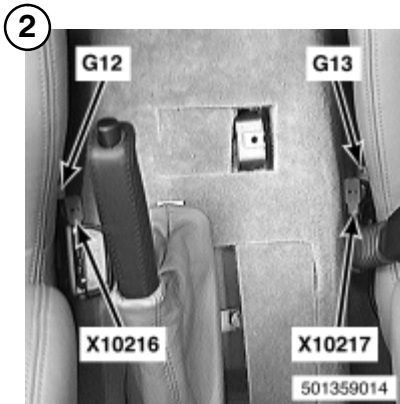

G12
DRIVER'S SIDE
PYROTECHNICAL
BELT TENSIONER

G13
PASSENGER'S
SIDE
PYROTECHNICAL
BELT TENSIONER

X10216
X10217

501359014

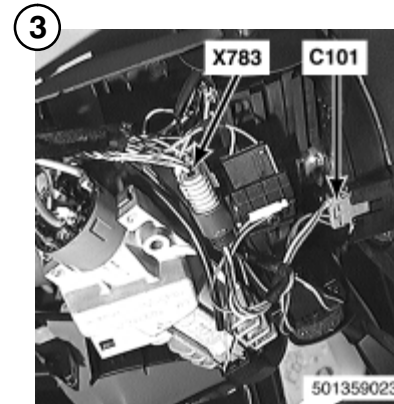

C101
CONTACT RING

X783

501359023

COMPONENT LOCATION VIEWS

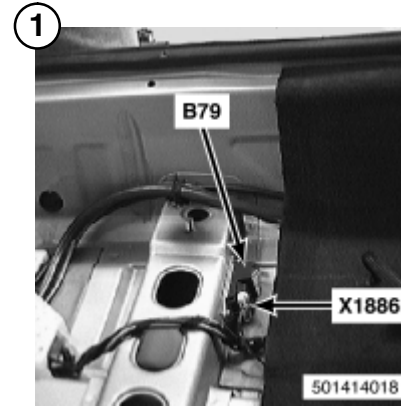
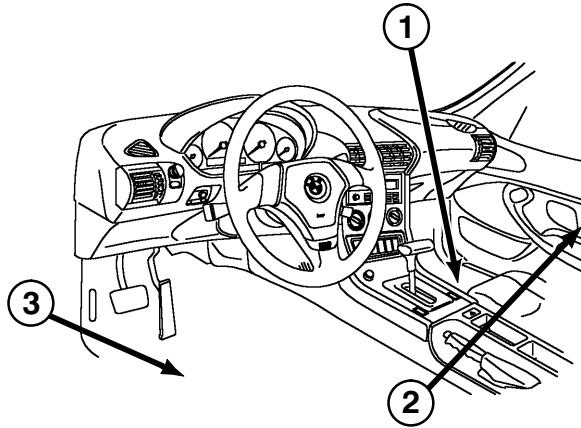

B79
PASSENGER'S
SIDE IMPACT
SENSOR

X1886

501414018

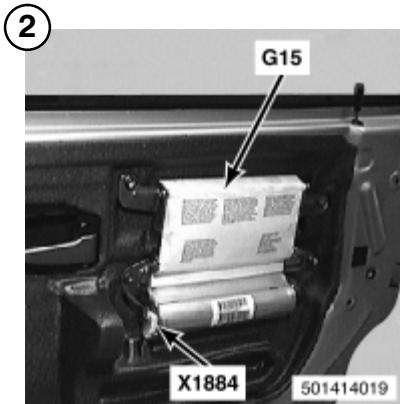

G15
RIGHT SIDE AIR
BAG GAS
GENERATOR

X1884

501414019

X1884

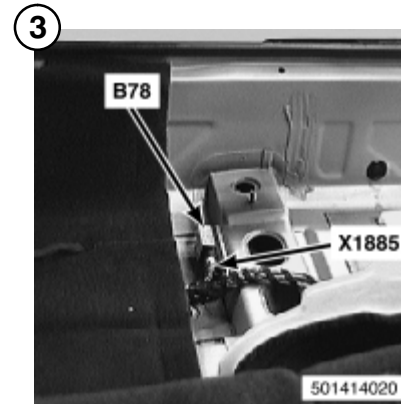

B78
DRIVER'S SIDE
IMPACT SENSOR

X1885

501414020

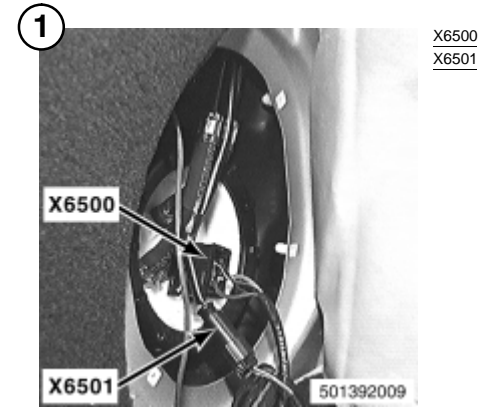
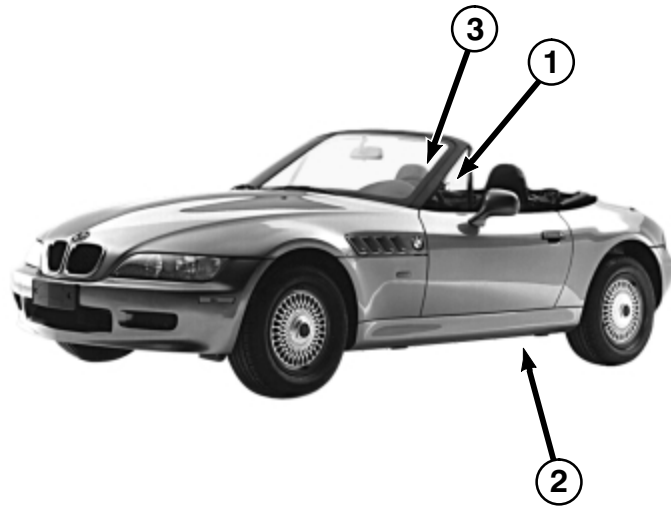

X6500
X6501

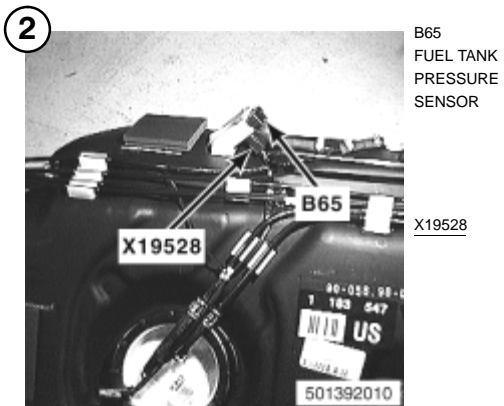

B65
FUEL TANK
PRESSURE
SENSOR

X19528

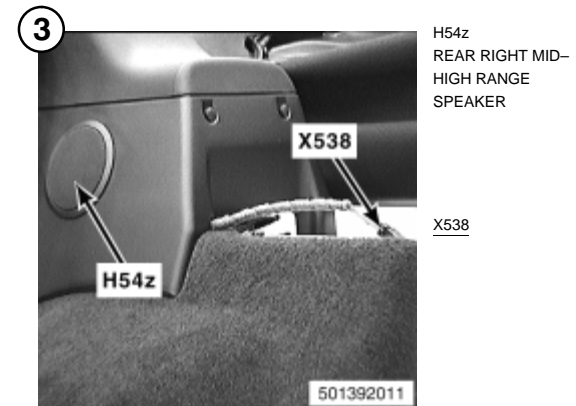

H54z
REAR RIGHT MID-
HIGH RANGE
SPEAKER

X538

COMPONENT LOCATION VIEWS

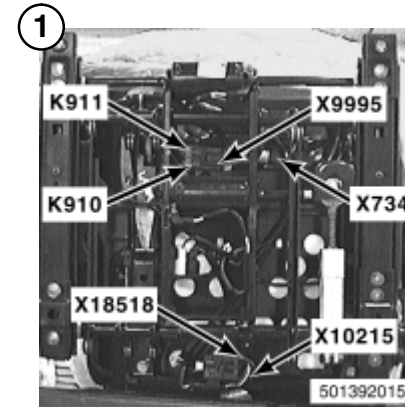
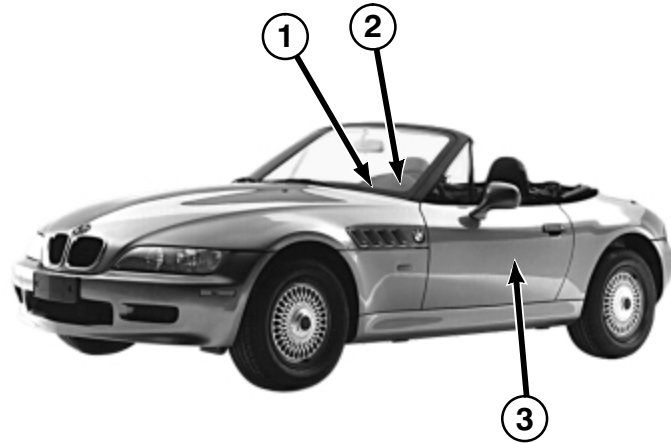

K910
PASSENGER'S
SEAT TILT ADJUST
CUT-OFF RELAY

K911
PASSENGER'S
SEAT LENGTH
ADJUST CUT-OFF
RELAY

X734
X9995
X10215
X18518

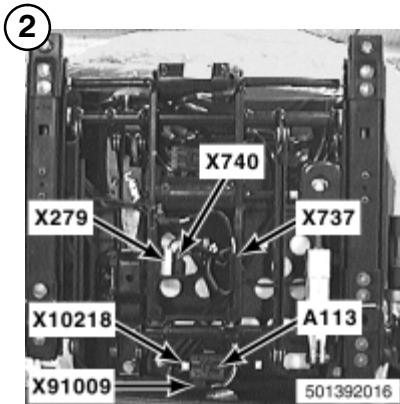

A113
SEAT OCCUPANCY
DETECTOR

X279
X737
X740
X10218
X91009

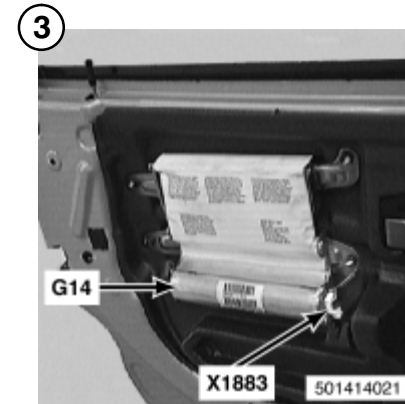

G14
LEFT SIDE AIR BAG
GAS GENERATOR

X1883

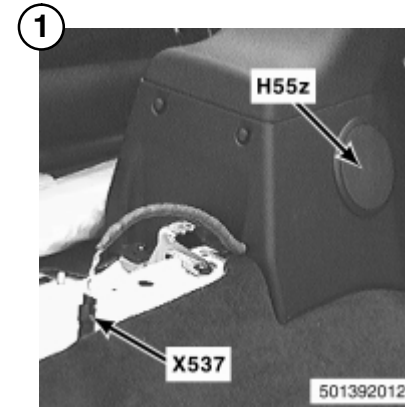
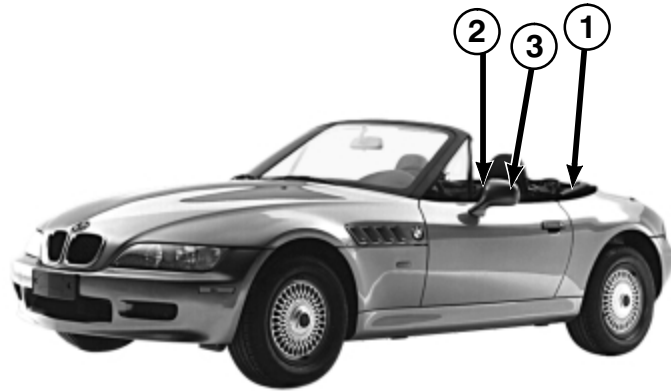

H55z
REAR LEFT MID-
HIGH RANGE
SPEAKER

X537

501392012

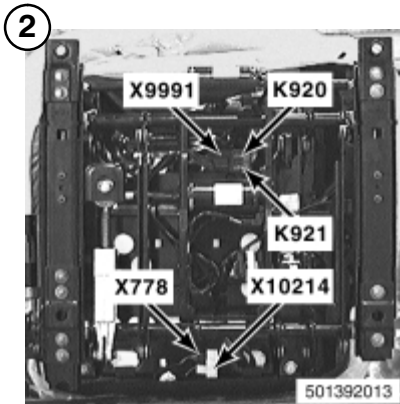

K920
DRIVER'S SEAT
TILT ADJUST CUT-
OFF RELAY

K921
DRIVER'S SEAT
LENGTH ADJUST
CUT-OFF RELAY

X778
X9991
X10214

501392013

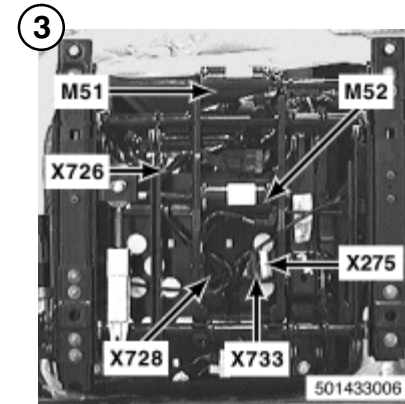

M51
DRIVER'S SEAT
MOVEMENT
MOTOR

M52
DRIVER'S SEAT
HEIGHT MOTOR

X726
X728
X733
X275

501433006



8000.0 SPLICE LOCATION VIEWS

SPLICE	HARNESS	PAGE NUMBER	SPLICE	HARNESS	PAGE NUMBER
X181–X185	BODY	8000.0-03	X849–X851	DRIVER'S DOOR	8000.0-04
X188	BODY	8000.0-04	X876–X877	RADIO/HIFI/CD	NOT SHOWN
X189	IHKS	NOT SHOWN	X878–X888	BODY	8000.0-03
X191	BODY	8000.0-04	X942	PASSENGER'S DOOR	8000.0-04
X195	BODY	8000.0-03	X985	IHKS	NOT SHOWN
X196–X197	BODY	8000.0-04	X1015–X1027	BODY	8000.0-03
X203	BODY	8000.0-03	X1028–X1029	BODY	8000.0-04
X213	BODY	8000.0-04	X1036–X1047	BODY	8000.0-03
X216–X223	BODY	8000.0-03	X1055	BODY	8000.0-04
X245–X246	BODY	8000.0-03	X1066–X1076	BODY	8000.0-03
X443–X444	BODY	8000.0-04	X1079	BODY	8000.0-04
X445	BODY	8000.0-03	X1100–X1115	BODY	8000.0-03
X449	BODY	8000.0-04	X1149	BODY	8000.0-03
X450	BODY	8000.0-03	X1152–X1164	BODY	8000.0-03
X453–X465	BODY	8000.0-04	X1168–X1186	BODY	8000.0-03
X470	BODY	8000.0-03	X1214	BODY	8000.0-03
X530	BODY	8000.0-03	X1225–X1226	BODY	8000.0-04
X576–X595	BODY	8000.0-03	X1234–X1236	BODY	8000.0-04
X697–X699	BODY	8000.0-03	X1258	BODY	8000.0-03
X805	BODY	8000.0-04	X1263	BODY	8000.0-04
X806	BODY	8000.0-03	X1264	BODY	8000.0-03
X814–X818	IHKS	NOT SHOWN	X1280	BODY	8000.0-03
X824–X830	RADIO/HIFI/CD	NOT SHOWN	X1403	BODY	8000.0-03



SPLICE LOCATION VIEWS

SPLICE	HARNESS	PAGE NUMBER	SPLICE	HARNESS	PAGE NUMBER
X1429–X1435	IHKS	NOT SHOWN	X7845–X7846	M44 ENGINE	8000.0-05
X1541–X1542	BODY	8000.0-03	X8000–X8015	M52/S52 ENGINE	8000.0-06
X1608	BODY	8000.0-04	X8004–X8005	M44 ENGINE	8000.0-05
X1610–X1616	BODY	8000.0-03	X8008	M44 ENGINE	8000.0-05
X1617–X1618	BODY	8000.0-04	X8015	M44 ENGINE	8000.0-05
X1620–X1625	BODY	8000.0-03	X8038	M52/S52 ENGINE	8000.0-06
X1682	BODY	8000.0-03	X8051	M52/S52 ENGINE	8000.0-06
X2233	BODY	8000.0-03	X8056	M44 ENGINE	8000.0-05
X6410	M44 ENGINE	8000.0-05	X8071–X8074	M52/S52 ENGINE	8000.0-06
X6411–X6415	M52/S52 ENGINE	8000.0-06	X8073	M44 ENGINE	8000.0-05
X6420	M52/S52 ENGINE	8000.0-06	X8090–X8091	M52/S52 ENGINE	8000.0-06
X6458–X6460	M52/S52 ENGINE	8000.0-06	X8103	M52/S52 ENGINE	8000.0-06
X6460–X6492	M44 ENGINE	8000.0-05	X8564–X8565	M52/S52 ENGINE	8000.0-06
X6475	M52/S52 ENGINE	8000.0-06	X8564–X8576	M44 ENGINE	8000.0-05
X6492	M52/S52 ENGINE	8000.0-06	X9430	BODY	8000.0-03
X6810	M52/S52 ENGINE	8000.0-06	X9454	BODY	8000.0-03
X6820–X6822	M52/S52 ENGINE	8000.0-06	X9992–X9993	DRIVER'S SEAT	NOT SHOWN
X6820–X6823	M44 ENGINE	8000.0-05	X9996–X9997	PASSENGER'S SEAT	NOT SHOWN
X6830–X6835	M52/S52 ENGINE	8000.0-06	X10008	BODY	8000.0-03
X6832–X6891	M44 ENGINE	8000.0-05	X10009	BODY	8000.0-04
X6860–X6869	M52/S52 ENGINE	8000.0-06	X10014–X10055	BODY	8000.0-03
X6900	M44 ENGINE	8000.0-05	X10064	BODY	8000.0-04
X6949	BODY	8000.0-03	X10100–X10126	BODY	8000.0-03



SPLICE LOCATION VIEWS

Z3

SPLICE	HARNESS	PAGE NUMBER	SPLICE	HARNESS	PAGE NUMBER
X10169	M44 ENGINE	8000.0-05	X80253	M52/S52 ENGINE	8000.0-06
X10189	BODY	8000.0-03			
X10251–X10252	BODY	8000.0-03			
X11264–X11284	BODY	8000.0-03			
X11291	BODY	8000.0-04			
X11337–X11353	BODY	8000.0-03			
X11355	BODY	8000.0-04			
X11357	BODY	8000.0-03			
X13007	BODY	8000.0-03			
X13011–X13047	BODY	8000.0-04			
X13134	BODY	8000.0-03			
X13289	BODY	8000.0-03			
X18061	BODY	8000.0-03			
X18328	BODY	8000.0-03			
X18510	BODY	8000.0-03			
X19513	RADIO/HIFI/CD	NOT SHOWN			
X19002–X19004	BODY	8000.0-04			
X19525–X19526	BODY	8000.0-03			
X64109	BODY	8000.0-03			
X64119	BODY	8000.0-03			
X64129	BODY	8000.0-03			
X64591	BODY	8000.0-04			
X68309	IHKS	NOT SHOWN			

04/99

8000.0-02

1998

SPLICE LOCATION VIEWS
BODY HARNESS

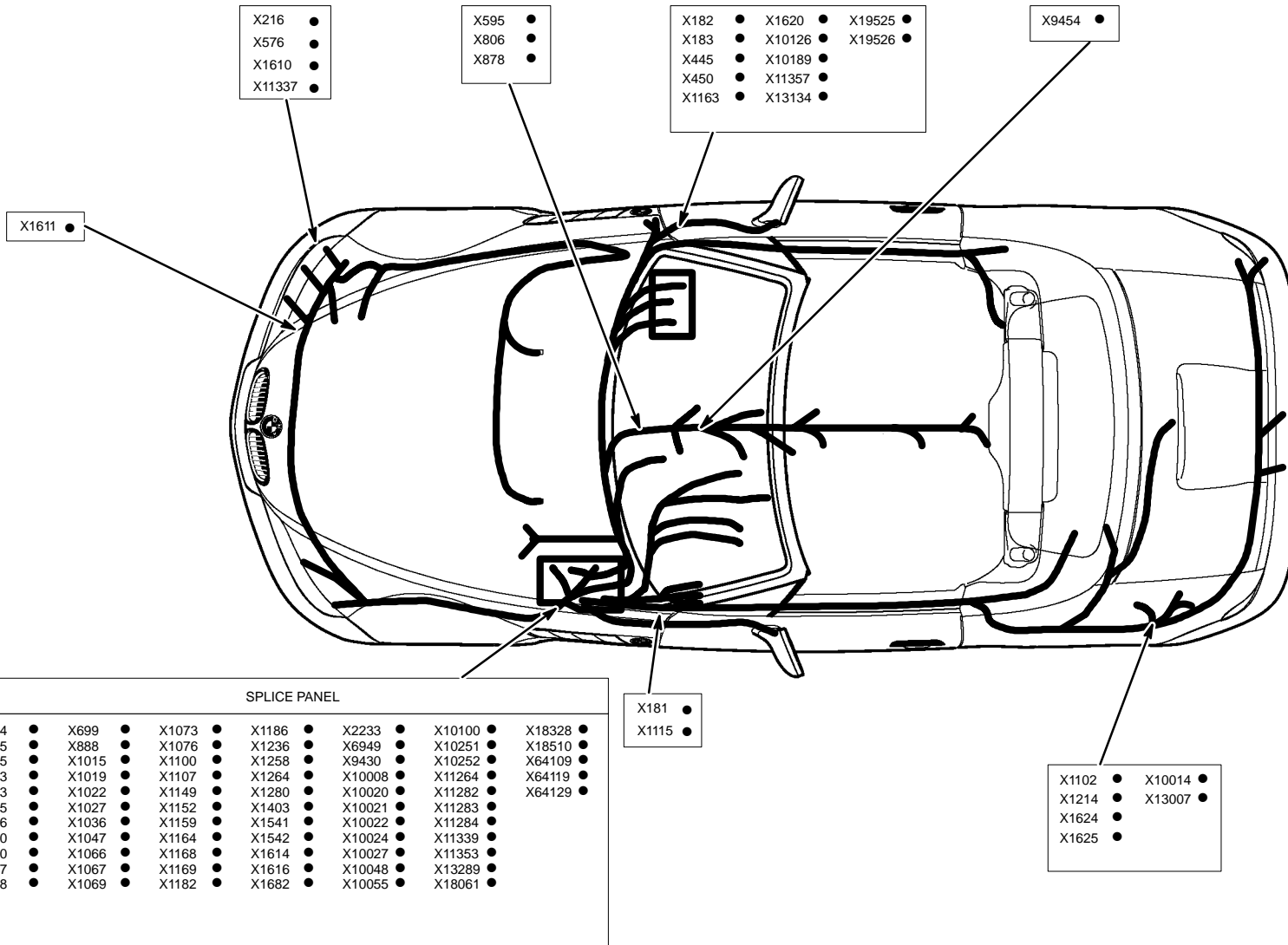



SPLICE LOCATION VIEWS

BODY HARNESS

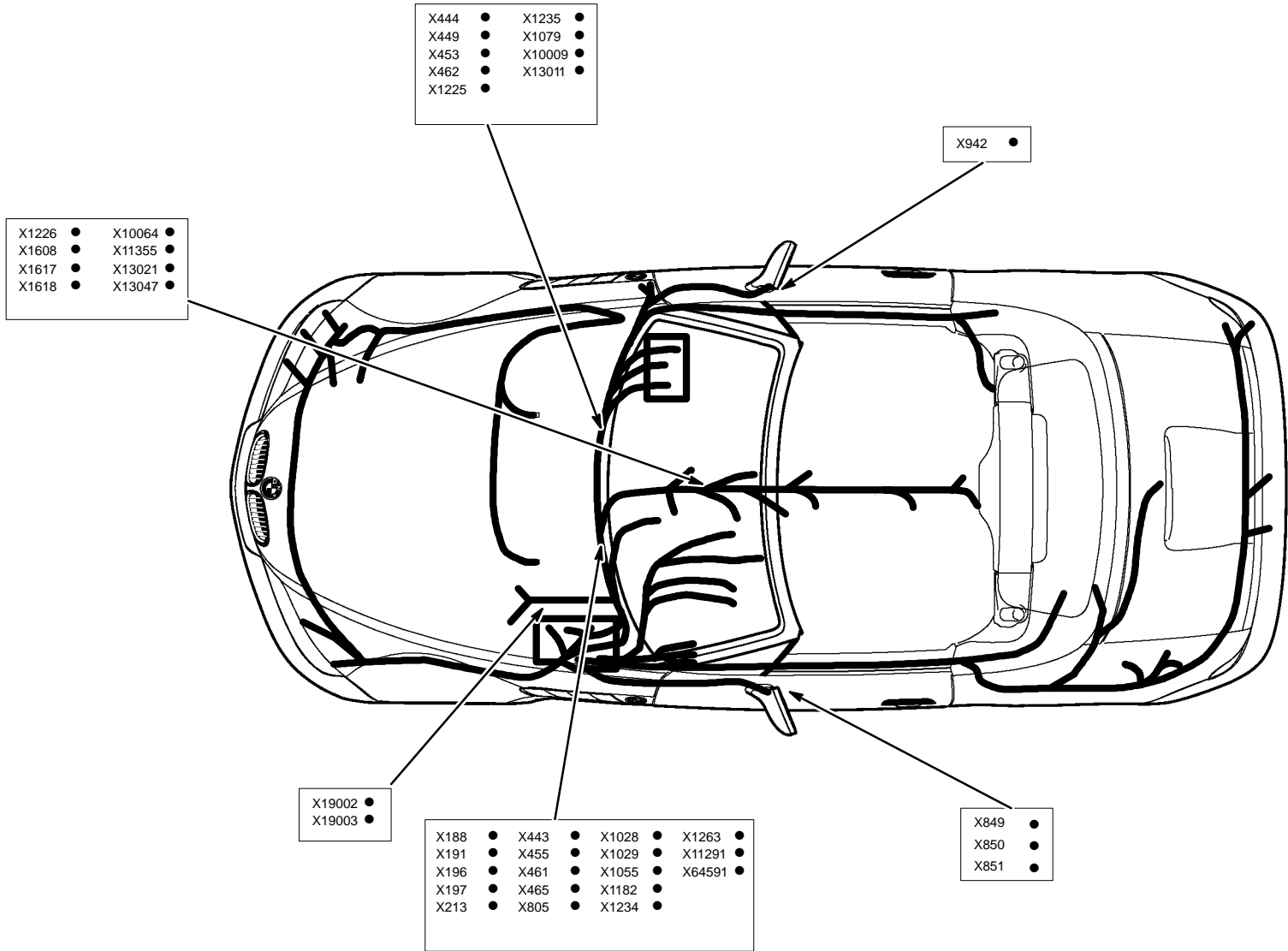



SPLICE LOCATION VIEWS

ENGINE HARNESS M44

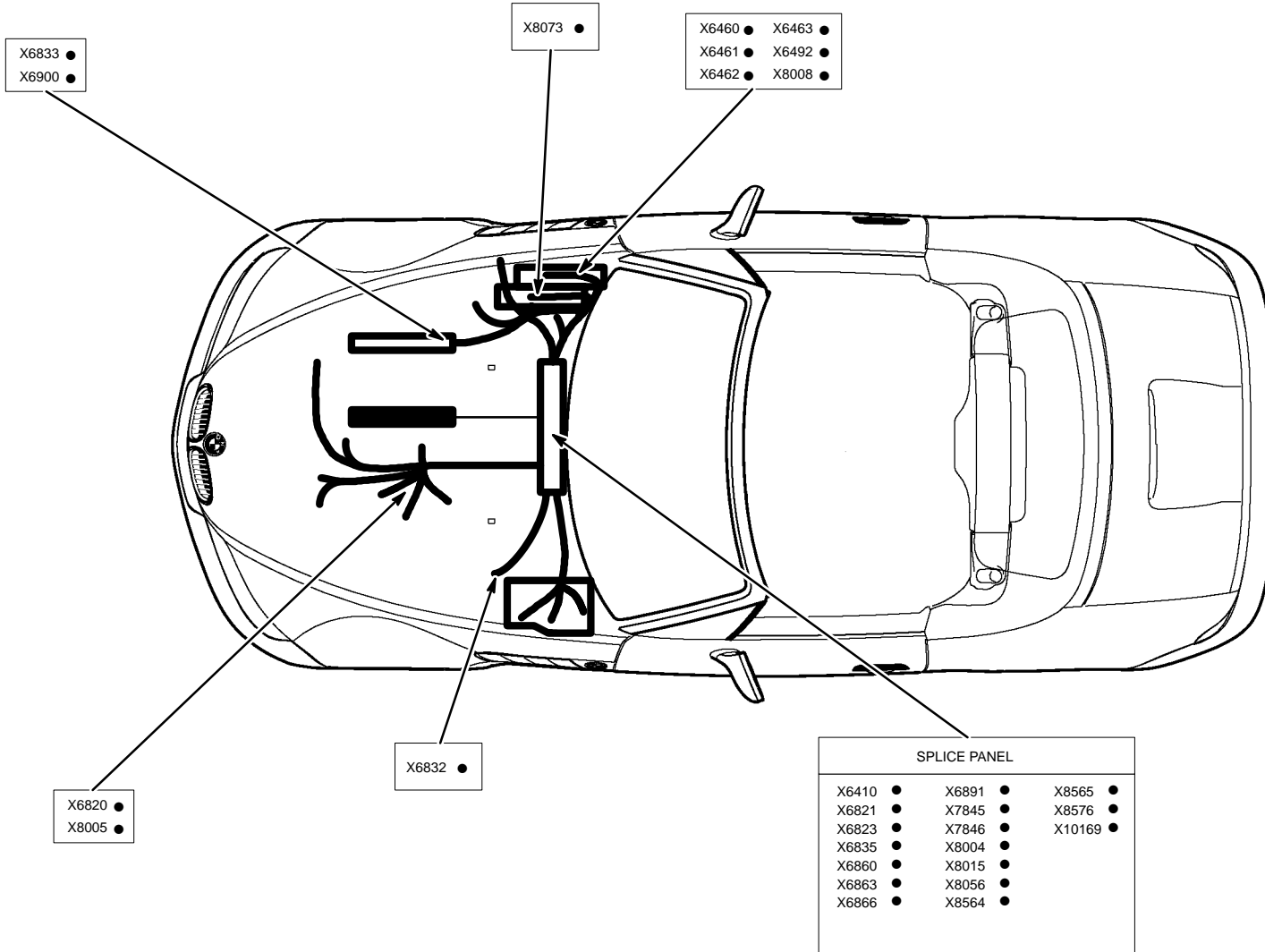

SPLICE LOCATION VIEWS

ENGINE HARNESS M52/S52

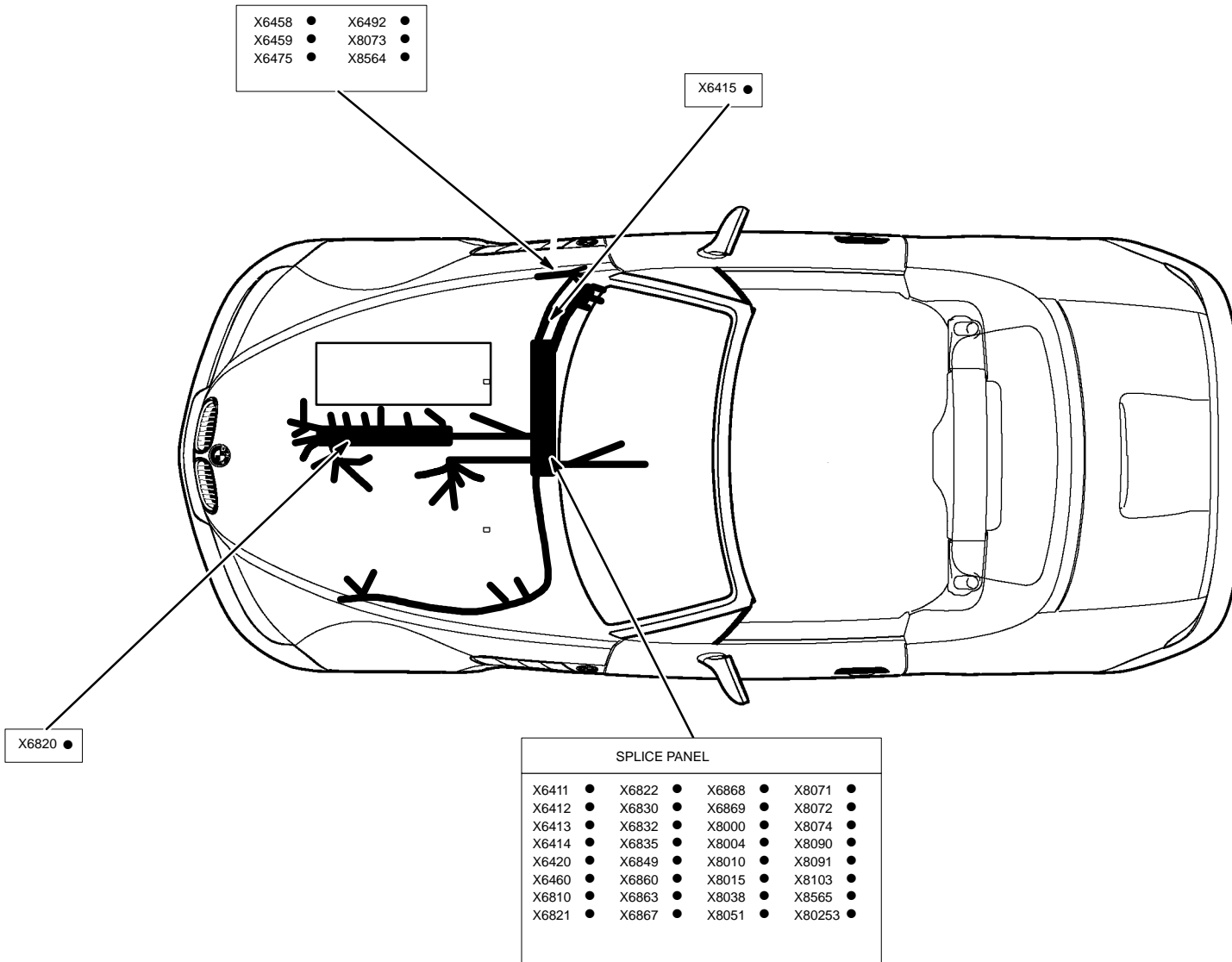

FIG. 1

B880001.00

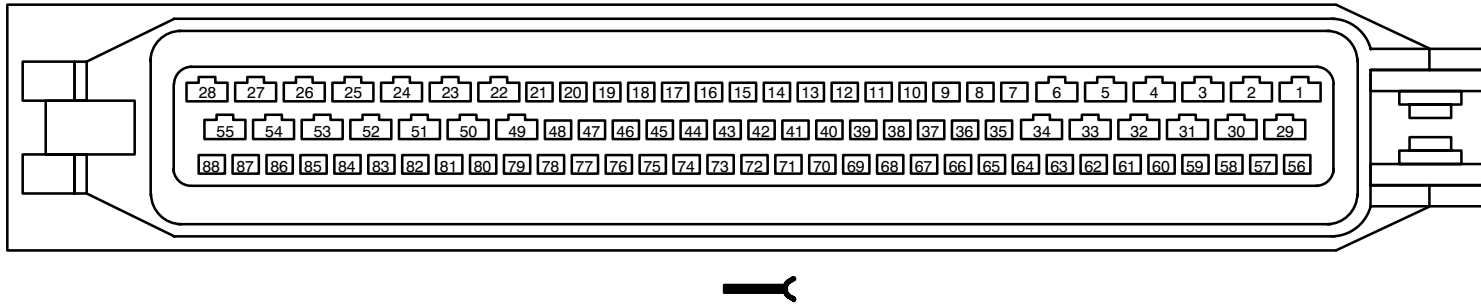
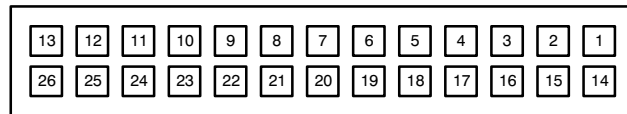

FIG. 2

B260005.00



CONNECTOR VIEWS

FIG. 1

B030024

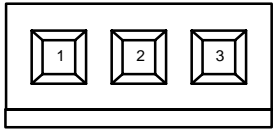

FIG. 2

B300005.00

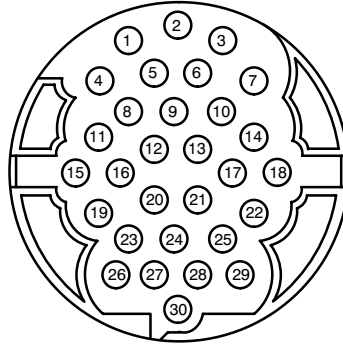

FIG. 3

B120001.01

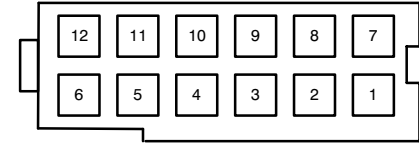

FIG. 4

B030048a

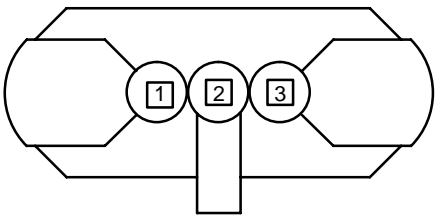

FIG. 5

B040031.00

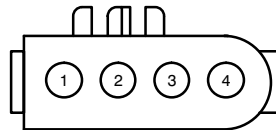

FIG. 6

B120015

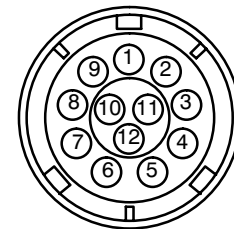

FIG. 1

B080002.00

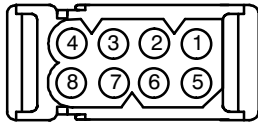

FIG. 2

B170001.00

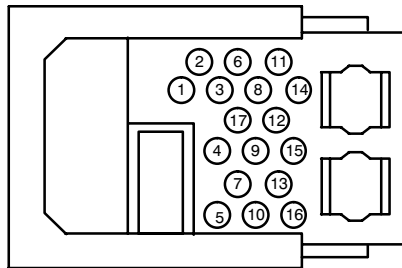

FIG. 3

B100008.00

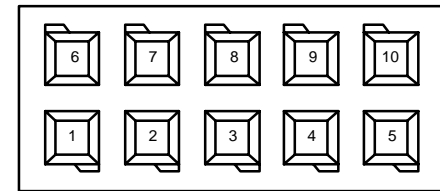

FIG. 4

B120004.01

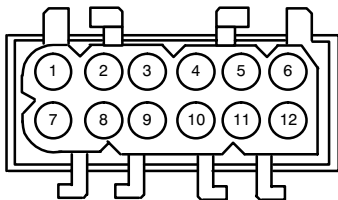

FIG. 5

B030004.01

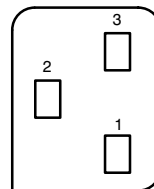

FIG. 6

B050003.00

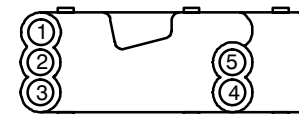

FIG. 1

B040004.00

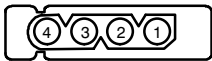

FIG. 2

B040018.05

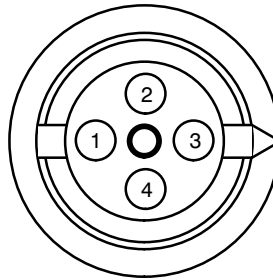

FIG. 3

B040023.00

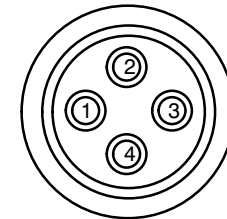

FIG. 4

B090002.00

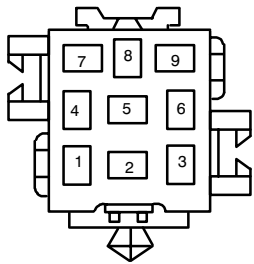

FIG. 5

B260002.01

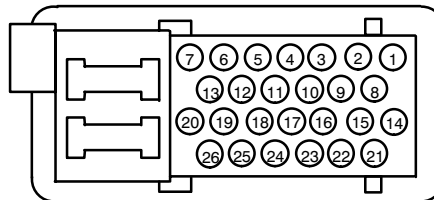
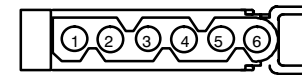

FIG. 6

B060001.02



CONNECTOR VIEWS

FIG. 1

B200003.00

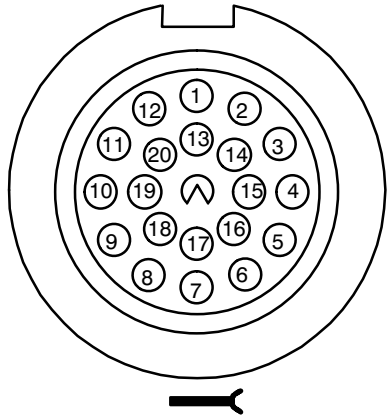

FIG. 2

B070005.00

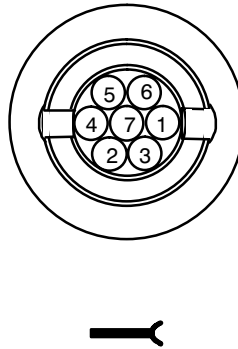

FIG. 3

B030003.00

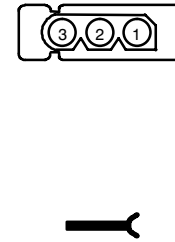

FIG. 4

B250001.02

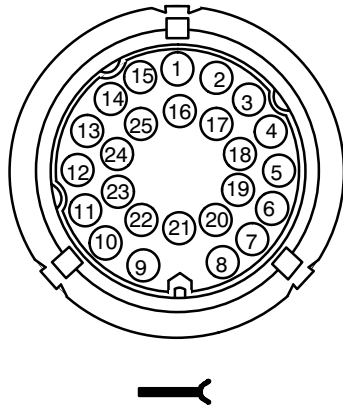
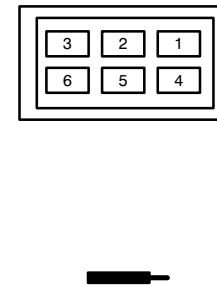

FIG. 5

B060019.03



CONNECTOR VIEWS

FIG. 1

B150002.00

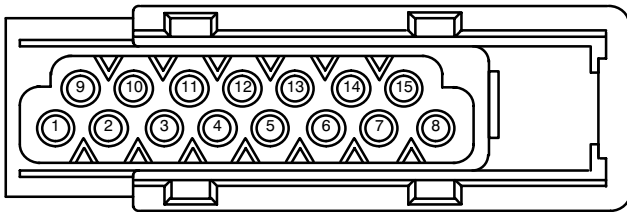

FIG. 2

B030046.00

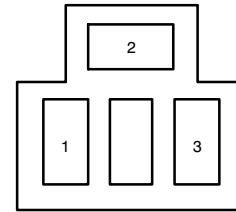

FIG. 3

B060038.00

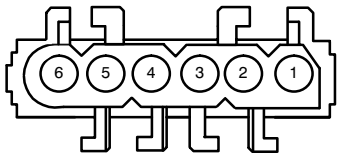

FIG. 4

B040027.00

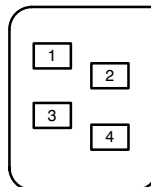

FIG. 5

B030006.00

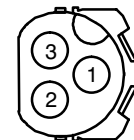

FIG. 1

B0400028.00

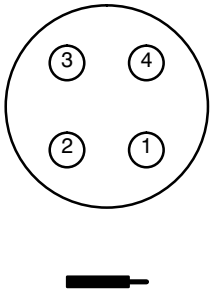

FIG. 2

B080020.00

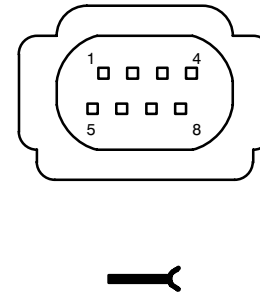

FIG. 3

B0300044.00

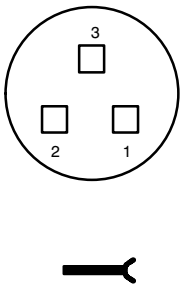

FIG. 4

B0300011.00

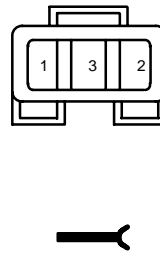

FIG. 5

B060041.00

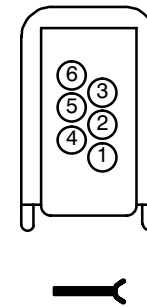

FIG. 1

B040026

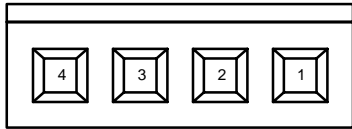

FIG. 2

B120006.00

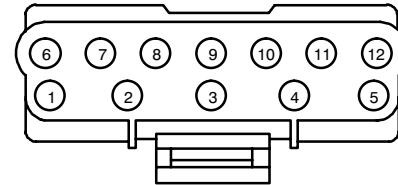

FIG. 3

B180000.00

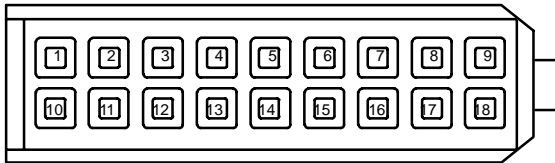

FIG. 4

B060037.00

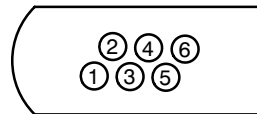

FIG. 5

B030042.00

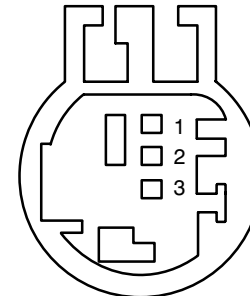

FIG. 1

B160002.00

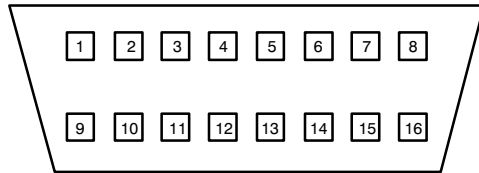

FIG. 2

B060013.00

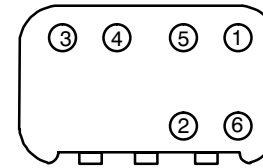

FIG. 3

B080013.00

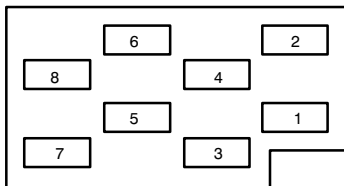
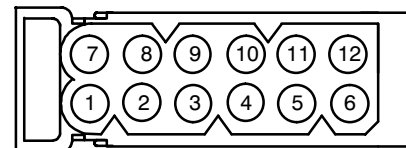

FIG. 4

B120002.02





Z3

CONNECTOR VIEWS

FIG. 1

B060043.00

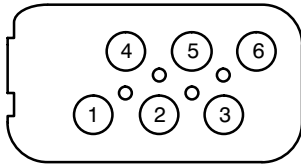

FIG. 2

B070012.00

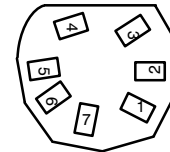

FIG. 3

B420000.00

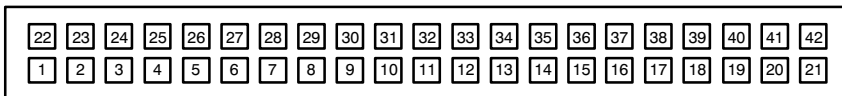
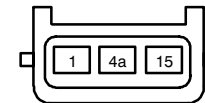

FIG. 4

B030015.08





Z3

CONNECTOR VIEWS

FIG. 1

B100001.00

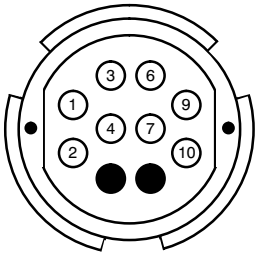

FIG. 2

B030018.02

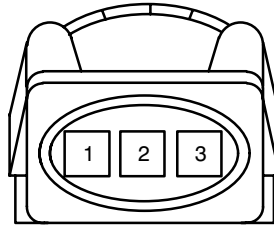

FIG. 3

B040023.02

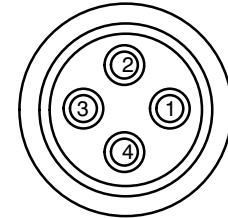

FIG. 4

B040030.00

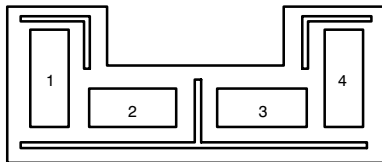
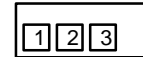

FIG. 5

B030036.01



CONNECTOR VIEWS

FIG. 1

B030022.00

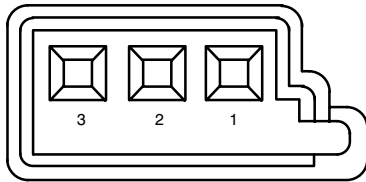

FIG. 2

B500000.00

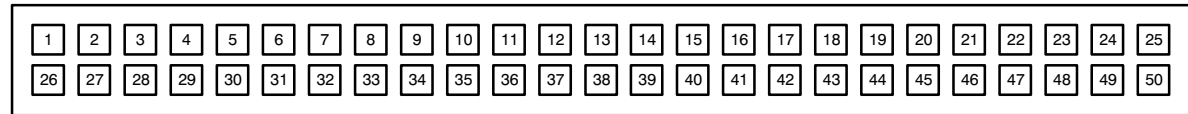

FIG. 3

B550002.00

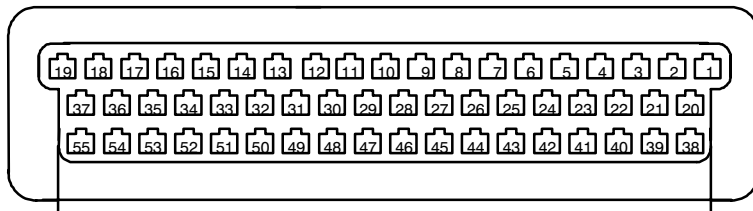

FIG. 4

B160001.00

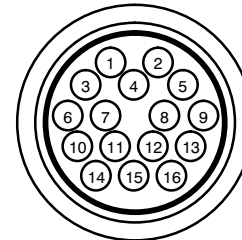

FIG. 1

B050001.00

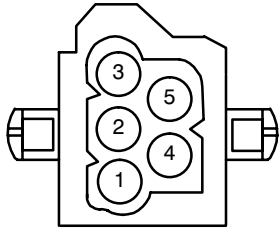

FIG. 2

B100004.02

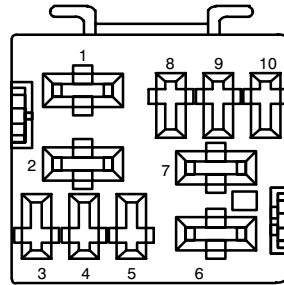

FIG. 3

B060042

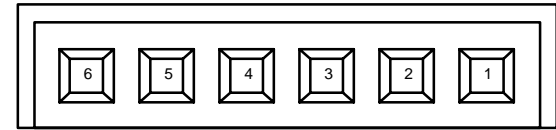
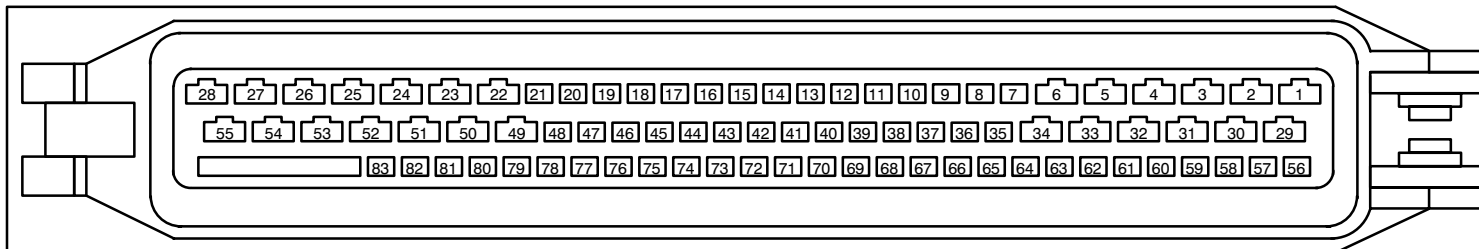

FIG. 4

B830001.00



Free Manuals Download Website

<http://myh66.com>

<http://usermanuals.us>

<http://www.somanuals.com>

<http://www.4manuals.cc>

<http://www.manual-lib.com>

<http://www.404manual.com>

<http://www.luxmanual.com>

<http://aubethermostatmanual.com>

Golf course search by state

<http://golfingnear.com>

Email search by domain

<http://emailbydomain.com>

Auto manuals search

<http://auto.somanuals.com>

TV manuals search

<http://tv.somanuals.com>