



MODELS BE2136 Electric Conveyor Oven



OPTIONS AND ACCESSORIES

(AT ADDITIONAL CHARGE)

- High speed conveyor (1-10 minute bake time)
- 76" (1930mm) long conveyor in lieu of standard 60" (1524mm) long conveyor
- 9" (228mm) Twin stainless steel wire mesh conveyor belt with individually adjustable bake time settings
- Stacking kit to properly stack a BE2136 on top of an existing SG2136E
- One year additional extended warranty*

STANDARD FEATURES

- Impingement deluxe dual air return that improves cooking results and saves energy
- Solid state controls
- Temperature controller's built in auto tune feature improves overall conveyor oven performance
- Microprocessor-controlled conveyor speed with motor feedback
- Large front loading door with window and stainless steel handle
- Portable stand (single, double, triple stack ovens)
- Stackable to three high
- Stainless steel under shelf on single and double stack ovens
- Removable folding conveyor frame and belt assembly
- Removable 8" (203mm) shelf extension (entrance end)
- Adjustable conveyor belt tension
- Field reversible conveyor belt direction
- Product stop (exit end)
- One year parts and labor warranty*
- Start Up by our Authorized Service Provider to activate the warranty (USA and Canada only)*

* For all international markets, contact your local distributor.

Project _____

Item No. _____

Quantity _____

BE2136

Blodgett gas fired conveyor oven with 18" (457mm) wide conveyor belt and 36" (915mm) long baking zone length. Single, double or triple stack models.

All data is shown per oven section, unless otherwise indicated.

EXTERIOR CONSTRUCTION

- Stainless steel front, top, sides, and interior
- Fully insulated on bottom, top, front and rear
- Easy serviceable access to all components
- Front and top surfaces are cool to the touch
- Full drop down front window
- Finished aluminized steel back

INTERIOR CONSTRUCTION

- Stainless steel outer (finger) plates
- 18" (457mm) wide stainless steel wire mesh conveyor belt
- 36" (915mm) long bake chamber
- Two blower inlets in the plenum for forced air circulation supplying top and bottom air flow
- Standard or Customer specific finger set that allows control of 8 heat zones inside the bake chamber. Finger set consists of manifolds, inner plates, outer plates and blank plate(s).

OPERATION

- Solid state digital controls to display set point and actual bake chamber temperature(s) as well as bake time.
- Maximum Temperature is 550 degrees F (one degree increment)
- 3 – 30 minute bake time (one second increment)
- Product clearance 3-1/2" (889mm)
- Heat transferred through forced directed hot air impingement
- Open vented baking chamber
- Tubular resistance heating elements
- Four blower cooling fans
- Easy to clean – no tools required

* For all international markets, contact your local distributor.



BLODGETT OVEN COMPANY

www.blodgett.com

1400 Toastmaster Drive, Elgin, IL USA 60120
Phone: (847) 741-3300 • Fax: (847) 741-0015



MODEL BE2136

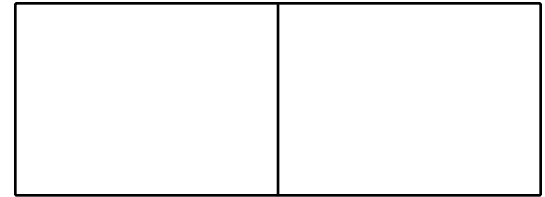

APPROVAL/STAMP

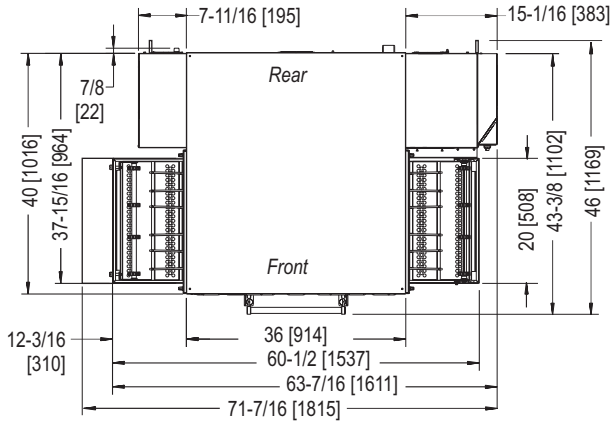

TOP VIEW

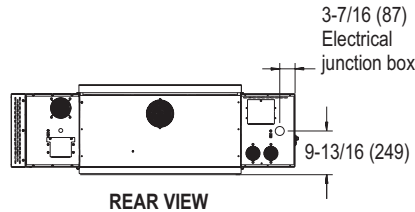

REAR VIEW

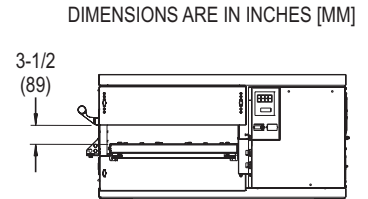

END VIEW

DIMENSIONS ARE IN INCHES [MM]

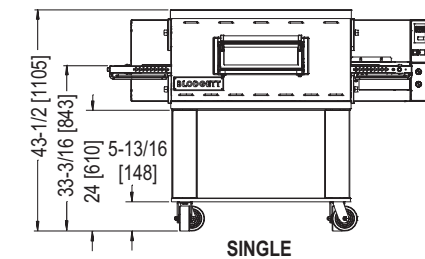

SINGLE

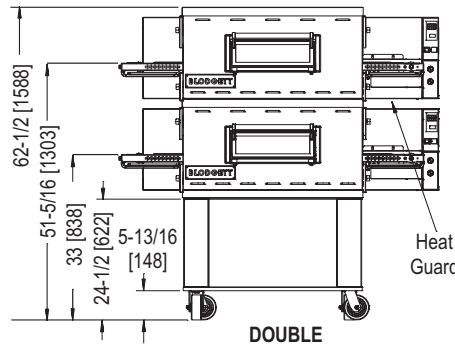

DOUBLE

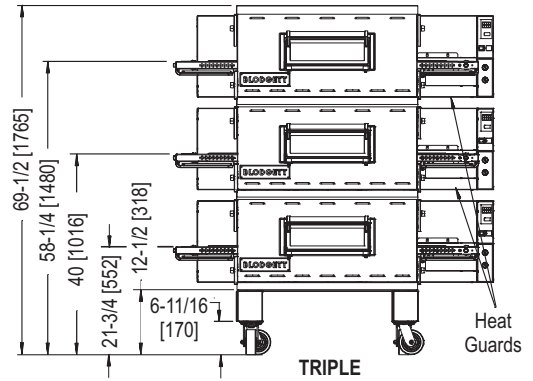

TRIPLE

SHORT FORM SPECIFICATIONS

Provide Blodgett conveyor model BE2136 electric conveyor oven. Unit shall cook by means of forced, heated air. Unit shall be (single/double/triple) deck. Each deck shall be fully independent, of stainless steel construction, and fully insulated on all sides. Provide with electrically heated baking compartment with two blowers to evenly distribute heat across baking zone. Conveyor belt shall be single - 18" (457mm) belt constructed of stainless steel wire mesh; baking zone length shall be 36" (915mm). Unit shall be provided with drop down front window. Control panel shall be solid state with 550°F (288°C) maximum thermostat and LCD display of 3-30 minutes adjustable belt speed. Provide start-up inspection service by a factory authorized service agent. Provide options and accessories as indicated.

DIMENSIONS:

Floor space	60" (1524mm) W x 46" (1169mm) L
Product clearance	3-1/2" (89mm)
Recommended minimum wall clearance	
Left and right side	1" (25mm)
Rear	3" (76mm)

Baking zone

Width	18" (457mm)
Length	36" (914mm)

MAXIMUM INPUT: (per section)

BE2136	17 kW
--------	-------

POWER SUPPLY (must have dedicated ground)

Domestic	208 VAC, 50/60 hz, 3 ph, 54 amp, 17 kW, 3-wire plus gnd 240 VAC, 50/60 hz, 3 ph, 47 amp, 17 kW, 3-wire plus gnd
International	380 VAC, 50/60 hz, 3 ph, 32 amp, 17 kW, 3-wire plus N and gnd 480 VAC, 50/60 hz, 3 ph, 27 amp, 17 kW, 3-wire plus N and gnd
CE	380 VAC, 50/60 hz, 3 ph, 32 amp, 17 kW, 3-wire plus N and gnd

MINIMUM ENTRY CLEARANCE:

Uncrated	19-1/2" (495mm)
----------	-----------------

SHIPPING INFORMATION:

Approx. Weight:

Single	658 lbs. (299 kg)
Double	1255 lbs. (570 kg)
Triple	2449 lbs. (1112 kg)

Crate Size:

BE2136	65" L x 49" W x 42" H (1651 x 1245 x 1067 mm)
--------	---

NOTE: Blodgett Oven, in accord with its policy to continually improve its products, reserves the right to change materials or specifications without notice. Such revisions do not entitle the buyer to corresponding changes, improvements, additions, or replacements for previously purchased equipment.

BLODGETT OVEN COMPANY

www.blodgett.com • 1400 Toastmaster Drive, Elgin, IL USA 60120 • Phone: (847) 741-3300 • Fax: (847) 741-0015

Printed in U.S.A.

NOTE: FOR COMMERCIAL USE ONLY

P/N M10992 Rev B (5/08)

Free Manuals Download Website

<http://myh66.com>

<http://usermanuals.us>

<http://www.somanuals.com>

<http://www.4manuals.cc>

<http://www.manual-lib.com>

<http://www.404manual.com>

<http://www.luxmanual.com>

<http://aubethermostatmanual.com>

Golf course search by state

<http://golfingnear.com>

Email search by domain

<http://emailbydomain.com>

Auto manuals search

<http://auto.somanuals.com>

TV manuals search

<http://tv.somanuals.com>