

BLOOMFIELD INDUSTRIES

2 ERIK CIRCLE, P. O. Box 280
Verdi, NV 89439
telephone: 775-689-5700
fax: 888-492-2783
www.wellsbloomfield.com



Model 9102A Satellite Brewer with 9105SS Satellite

**OWNERS MANUAL
for
SATELLITE
COFFEE BREWER
with
ELECTRO-MECHANICAL
CONTROL
and
EXTERNALLY HEATED
SATELLITE SERVER**

**MODEL:
9102A
9104A**

Includes:

**Installation
Operation
Use & Care
Servicing Instructions**

PRINTED IN UNITED STATES OF AMERICA

WARRANTY STATEMENT

All electrical equipment manufactured by BLOOMFIELD INDUSTRIES is warranted against defects in materials and workmanship for a period of one year from the date of original installation or eighteen (18) months from the date of shipment from our factory, whichever comes first, and is for the benefit of the original purchaser, except that:

- a. airpots carry a 30 day parts warranty only.
- b. dispensers; i.e., tea and coffee carry a 90 days parts warranty only, excludes decanters.

THE FOREGOING OBLIGATION IS EXPRESSLY GIVEN IN LIEU OF ANY OTHER WARRANTIES, EXPRESSED OR IMPLIED, INCLUDING ANY IMPLIED WARRANTY OF MERCHANTABILITY OR FITNESS FOR A PARTICULAR PURPOSE, WHICH ARE HEREBY EXCLUDED.

BLOOMFIELD INDUSTRIES DIVISION / SPECIALTY EQUIPMENT MANUFACTURING CORPORATION SHALL NOT BE LIABLE FOR INDIRECT, INCIDENTAL OR CONSEQUENTIAL DAMAGES OR LOSSES FROM ANY CAUSE WHATSOEVER.

This warranty is void if it is determined that upon inspection by an Authorized Service Agency that the equipment has been modified, misused, misapplied, improperly installed, or damaged in transit or by fire, flood or act of God.

It also does not apply if the serial nameplate has been removed or unauthorized service personnel perform service. The prices charged by Bloomfield Industries for its products are based upon the limitations in this warranty. Seller's obligation under this warranty is limited to the repair of defects without charge by a Bloomfield Industries Authorized Service Agency or one of its sub-agencies. This service will be provided on customer's premises for non-portable models. Portable models (a device with a cord and plug) must be taken or shipped to the closest Authorized Service Agency, transportation charges prepaid, for services.

In addition to restrictions contained in this warranty, specific limitations are shown below (Additional Warranty Exclusions). Bloomfield Industries Authorized Service Agencies are located in principal cities.

This warranty is valid in the United States and void elsewhere. Please consult your classified telephone directory or your food service equipment dealer; or, for information and other details concerning warranty, write to:

**Service Parts Department
Bloomfield Industries
P.O. Box 280
Verdi, NV 89439**

Phone: (888) 492-2782

Fax: (888) 492-2783

SERVICE POLICY AND PROCEDURE GUIDE ADDITIONAL WARRANTY EXCLUSIONS

1. Resetting of safety thermostats, circuit breakers, overload protectors, or fuse replacements unless warranted conditions are the cause.
2. All problems due to operation at voltages other than specified on equipment nameplates; conversion to correct voltage must be the customer's responsibility.
3. All problems due to electrical connections not made in accordance with electrical code requirements and wiring diagrams supplied with the equipment.
4. Replacement of items subject to normal wear, to include such items as knobs and light bulbs. Normal maintenance functions including adjustment of thermostats, microswitches, and replacement of fuses and indicating lights are not covered under warranty.
5. All problems due to inadequate water supply, such as fluctuating, or high or low water pressure.
6. All problems due to mineral/calcium deposits, or contamination from chlorides/chlorines. De-liming is considered a preventative maintenance function and is not covered by warranty.
7. Full use, care and maintenance instructions are supplied with each machine. Those miscellaneous adjustments noted are customer responsibility. Proper attention will prolong the life of the machine.
8. Travel mileage is limited to sixty (60) miles from an authorized Service Agency or one of its sub-agencies.
9. All labor shall be performed during normal working hours. Overtime premium shall be charged to the customer.
10. All genuine Bloomfield replacement parts are warranted for ninety (90) days from date of purchase on non-warranted equipment. **Any use of non-genuine Bloomfield parts completely voids any warranty.**
11. Installation, labor and job check-out are not considered warranty.
12. Charges incurred by delays, waiting time or operating restrictions that hinder the service technicians ability to perform services are not covered by warranty. This includes institutional and correctional facilities.

SHIPPING DAMAGE CLAIMS PROCEDURE

NOTE: For your protection, please note that equipment in this shipment was carefully inspected and packaged by skilled personnel before leaving the factory. Upon acceptance of this shipment, the transportation company assumes full responsibility for its safe delivery.

IF SHIPMENT ARRIVES DAMAGED:

1. **VISIBLE LOSS OR DAMAGE:** Be certain that any visible loss or damage is noted on the freight bill or express receipt, and that the note of loss or damage is signed by the delivery person.
2. **FILE CLAIM FOR DAMAGE IMMEDIATELY:** Regardless of the extent of the damage.

3. **CONCEALED LOSS OR DAMAGE:** if damage is unnoticed until the merchandise is unpacked, notify the transportation company or carrier immediately, and file "CONCEALED DAMAGE" claim with them. This must be done within fifteen (15) days from the date the delivery was made to you. Be sure to retain the container for inspection.

Bloomfield Industries cannot assume liability for damage or loss incurred in transit. We will, however, at your request, supply you with the necessary documents to support your claim.

TABLE OF CONTENTS

WARRANTY STATEMENT	xi
SPECIFICATIONS	1
FEATURES & OPERATING CONTROLS	2
PRECAUTIONS & GENERAL INFORMATION	4
AGENCY APPROVAL INFORMATION	4
INSTALLATION	5
OPERATION	7
CLEANING INSTRUCTIONS	9
TROUBLESHOOTING SUGGESTIONS	11
SERVICING INSTRUCTIONS	12
EXPLODED VIEW, BREWER	18
EXPLODED VIEW, SATELLITE	21
SERVICE KITS	22
WIRING DIAGRAM	23

Thank You for purchasing this Bloomfield Industries appliance.

Proper installation, professional operation and consistent maintenance of this appliance will ensure that it gives you the very best performance and a long, economical service life.

This manual contains the information needed to properly install this appliance, and to use, care for and maintain or repair the appliance in a manner which will ensure its optimum performance.

SPECIFICATIONS

MODEL	VOLTS	WATTS	AMPS	POWER SUPPLY
9102A	120 VAC 1 ϕ	1790	15	4' cord with NEMA 5-15P
9104A	115/230 VAC 1 ϕ	4325	20	Requires 4-wire (L1, L2, Neut + Gnd) not provided

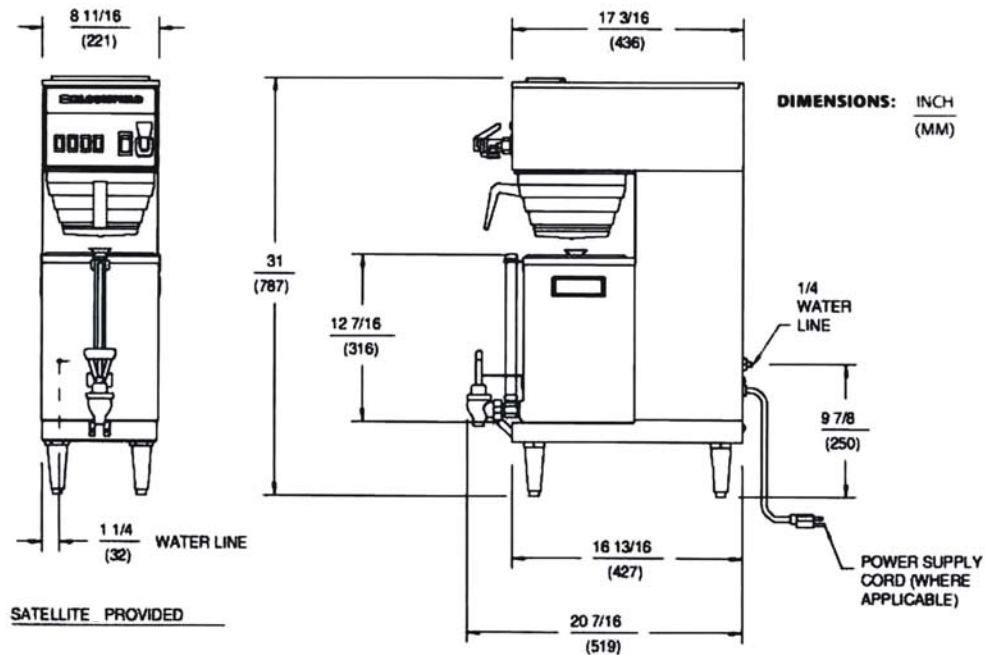

FEATURES AND OPERATING CONTROLS

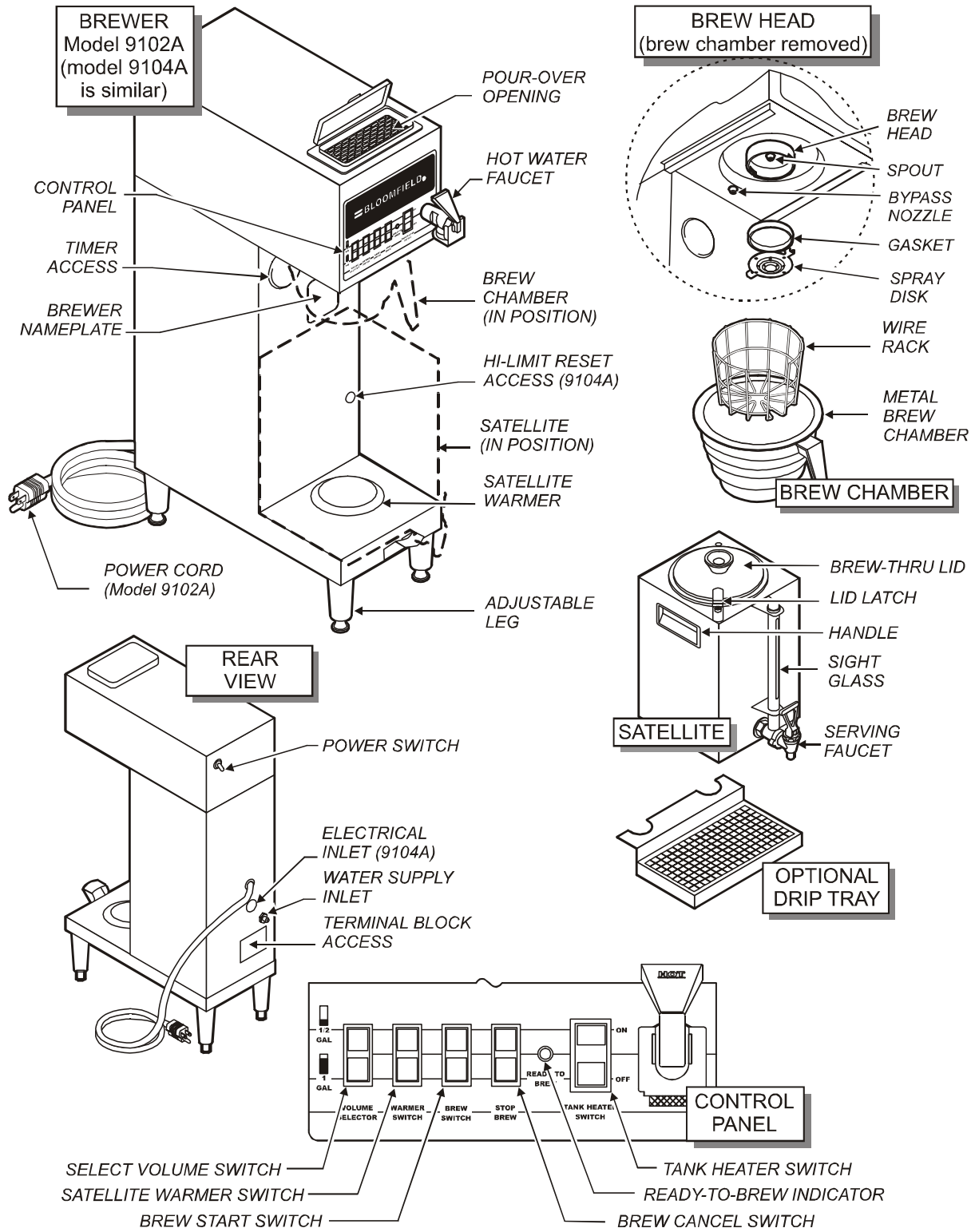

Fig 1. SS-1 Satellite Brewing System Features & Operating Controls

FEATURES AND OPERATING CONTROLS (continued)

Brewer

Adjustable Legs	Allows brewer to be leveled. Also allow clearance for cleaning underneath brewer.
Connector	Connects to satellite. Allows satellite heater to be energized. Allows brewer to sense that a satellite is in place.
Hot Water Faucet	Hot water dispensed here.
Nameplate	Lists manufacturer, model and serial number. Also lists voltage and wattage rating of brewer.

Control Panel

<i>Start Brew</i> Switch	Press to start a brew.
<i>Ready to Brew</i> Indicator	Glow when water in tank is up to temperature.
<i>Stop Brew</i> Switch	Press to cancel a brew in progress.
<i>Warmer</i> Switch	Energizes satellite warmer.
<i>Tank Heat</i> Switch	Applies power to tank heater element. Glows when <i>ON</i> .
<i>Volume Selector</i> Switch	Allows selection of 1/2 gallon or 1 gallon brew (9102A); or, 1 gallon or 1-1/2 gallon brew (9104A).

Brew Chamber

Brew Chamber	Holds coffee grounds during brew cycle.
Wire Rack	Holds paper filter and coffee grounds in proper position in brew chamber.

Satellite

Brew-Thru Lid	Allows entry of brewed coffee and dilution water into satellite. Minimizes splashing in the event satellite is tipped.
Handles	Allow the satellite to be safely carried.
Serving Faucet	Fresh coffee dispensed from satellite here.
Sight Glass	Check the level of coffee remaining here.

Drip Tray (optional)

Optional drip tray catches drips and spills from serving faucet. Easily removed for cleaning.

GENERAL INFORMATION AND PRECAUTIONS



WARNING: **Electric** **Shock hazard**

All servicing requiring access to non-insulated electrical components must be performed by a factory authorized technician.
DO NOT open any access panel which requires the use of tools. Failure to follow this warning can result in severe electrical shock.



CAUTION: **Burn Hazard**

Surfaces of the brewer and brew chamber may be hot to the touch and can cause burns on contact.

This appliance is intended for use in commercial establishments only.

This appliance is intended to brew hot beverage, specifically coffee, for human consumption. No other use is recommended or authorized by the manufacturer or its agents.

Operators of this appliance must be familiar with the appliance use, limitations and associated restrictions. Operating instructions must be read and understood by all persons using or installing this appliance.

Cleanliness of this appliance is essential to good sanitation. Read and follow all included cleaning instructions and schedules to ensure the safety of the food product.

Surfaces of the brewer, brew chamber and satellite can be hot to the touch, and may cause burns on contact.

Disconnect the brewer from electrical power before performing any maintenance or servicing.

DO NOT submerge satellites in water.

DO NOT splash or pour water over, onto or into any controls, control panel or wiring.

Any procedure which requires the use of tools must be performed by a qualified technician.

This manual is considered to be a permanent part of the appliance. This manual and all supplied instructions, diagrams, schematics, parts breakdown illustrations, notices and labels must remain with the appliance if it is sold or moved to another location.

This appliance is made in the USA. Unless otherwise noted, this appliance has American sizes on all hardware.

AGENCY APPROVAL INFORMATION



This dual satellite brewing system is  listed under E9253.



This dual satellite brewing system meets NSF Standard 4 only when installed and maintained per the instructions in this manual.

INSTALLATION INSTRUCTIONS

INSTALL LEGS

The brewer is provided with adjustable legs. Be sure all four legs are securely screwed into the base of the brewer.

LEVEL THE UNIT

The adjustable legs allow the brewer to be leveled. Set the brewer in its ultimate operating location and check for level with a spirit level. Adjust the brewer for level from front-to-rear, and from side-to-side. Be sure all four feet rest firmly on the counter.

PLUMBER'S INSTALLATION INSTRUCTIONS

IMPORTANT:

This equipment must be installed in accordance with the Basic Plumbing Code of the Building Officials and Code Administrators International (BOCA), and the Food Service Sanitation Manual of the Food and Drug Administration (FDA). Also, this equipment installation must comply with all local plumbing codes and ordinances.

IMPORTANT:

Brewer must be installed on a water line with a full-flow pressure between 20 psi and 90 psi.

NOTE: If water pressure varies greatly, or exceeds 90 psi at any time, a water pressure regulator must be installed. Plumbing installer must supply the regulator.

Brewer must be connected to a potable water supply. Bloomfield recommends not less than 1/4" copper tubing for installations of 12' or less, and not less than 3/8" copper tubing for installations exceeding 12'. Brewer must be connected to a COLD water line.

NOTE: DO NOT use a saddle tap for this water line connection.

A shut-off valve must be installed between the main water supply and the brewer. Plumbing installer must supply the shut-off valve. A 1/4-turn ball valve is recommended.

Brewer INLET FITTING is 1/4" Male Flare.

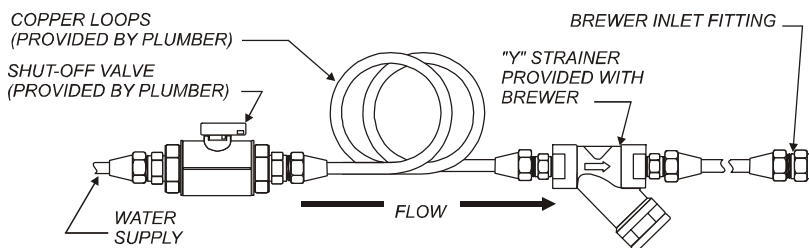

Fig. 3 Water Line Installation

Flush the water line before connecting to the brewer.



CAUTION:
Hazard from
Unstable Equipment

Rubber feet must be installed on each leg of the brewer. Legs must be adjusted so that all four feet rest firmly on the counter. Failure to properly install the feet can result in movement of the brewer, which can cause personal injury and/or damage to the brewer.

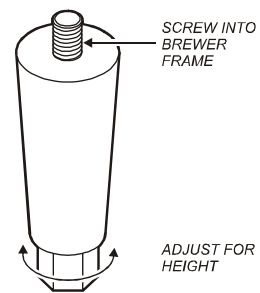

Fig. 2 Adjustable Legs

IMPORTANT:

In some areas, local codes require a backflow preventer (check valve) to be installed on the inlet water line. If a backflow preventer is used, you must install a **water hammer arrester** in the incoming line, between the backflow preventer and the brewer inlet, as far away from the brewer as space will allow. This will relieve the excessive back pressures that can cause faucet leaks and solenoid malfunctions.

NOTE:

While new-style brewers incorporate an internal strainer in the inlet solenoid, the provided "Y" strainer should be installed in the incoming water line for ease of servicing.

INSTALLATION INSTRUCTIONS (continued)



CAUTION: Electric Shock Hazard

Brewer must be properly grounded to a reliable earth ground to prevent possible shock hazard. Do not assume a plumbing line will provide such a ground. Electrical shock may cause serious injury.

IMPORTANT:

Initial set-up must be performed by a qualified installer or qualified service technician. Improper set-up will damage the brewer and void the warranty.

IMPORTANT:

Complete water line installation before connecting brewer to electrical power.

MAKE SURE THE FRONT PANEL "TANK HEATER" SWITCH IS IN THE OFF POSITION BEFORE CONNECTING BREWER TO ELECTRICAL POWER.

DO NOT turn the TANK HEATER switch ON until the water tank is filled. Heating element must be completely submerged in water at all times. Damage to the brewer caused by operating the heating elements dry is NOT covered by warranty.

ELECTRICIAN'S INSTALLATION INSTRUCTIONS

Refer to Electrical Specifications, page 1.

Brewer requires a dedicated single-phase circuit:

Model 9102A 120 Volt AC, 50/60 Hz 1Ø 20 Amps
NEMA 5-15R receptacle

Model 9104A 120/240 Volt AC, 50/60 Hz 1Ø 30 Amps
3-Wire (L1, L2, Neutral) + Ground

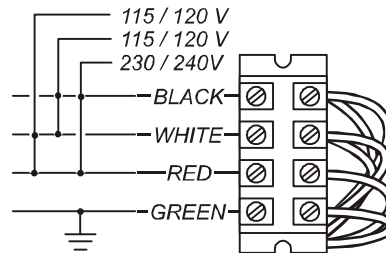

Fig. 4 Model 9104A Terminal Block

INITIAL SET-UP INSTRUCTIONS

Plumber's and Electrician's installation procedures must be completed before proceeding with the set-up.

Be sure all electrical connections are secure, and that all plumbing connections are secure and leak-proof.

1. CHECK BREWER FOR PROPER CONFIGURATION

Make sure spray disk gasket is in place INSIDE of spray head.

Make sure spray disk is properly installed.

Check hot water faucet for proper operation.

2. FILL WATER TANK

Be sure POWER SWITCH and TANK HEATER switch are OFF, then connect brewer to electric power.

Insert an empty brew chamber under the brew head. Place an empty satellite in position. Pour fresh cold water into the POUR-OVER OPENING until water flows from the brew basket.

3. CHECK HEATING

Turn POWER SWITCH ON, then press TANK HEATER switch ON. Water in tank will heat to brewing temperature in approximately 30 minutes. When the water temperature reaches the brew temperature setpoint, the READY-TO-BREW light will glow.

Hold a suitable container under the HOT WATER FAUCET, then open the faucet. Continue drawing water until all trapped air is expelled.

OPERATING INSTRUCTIONS

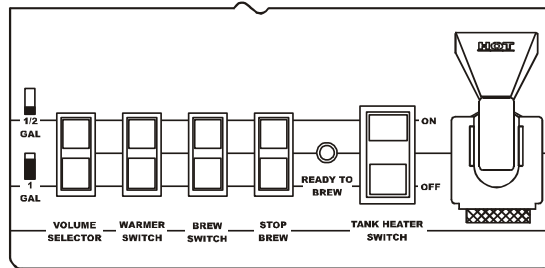

Fig. 5 Control Panel

BREWING COFFEE

Prepare the Brew Basket:

Make sure the wire rack is properly installed in the brew chamber.

Insert one (1) Bloomfield paper filter into the brew chamber. Make sure the filter is properly supported by the wire rack.

Add a measured amount of grounds to the brew basket. Recommendations (may vary, depending on type of coffee and personal taste preferences):

To brew 1/2 gallon, use 2.25 oz (64 gm) of coffee

To brew 1 gallon, use 4.50 oz (128 gm) of coffee

To brew 1-1/2 gallon, use 8.40 oz (240 gm) of coffee

Gently shake the basket to level the grounds.

Slide the brew chamber under the brew head.

Insert the Satellite:

Slide satellite under the brew chamber until it is fully seated. Press WARMER switch ON.

(9102A) Select Brew Volume:

Press VOLUME SELECT switch to **1/2 GAL** or **1 GAL**

(9104A) Select Brew Volume:

Press VOLUME SELECT switch to **1 GAL** or **1-1/2 GAL**

Start the Brew:

Press the **START BREW** switch.

NOTE: The brew can be cancelled at any time by pressing the **STOP BREW** switch.

At the end of the brew, be sure all water has stopped dripping before removing the brew chamber.

When the READY-TO-BREW light comes on, the brewer is ready to run another brew cycle.

Empty the Brew Basket:

Discard the grounds and the paper filter. Rinse the brew chamber under clear water.

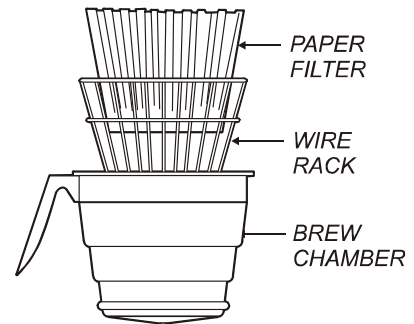

Fig. 6 Brew Basket

IMPORTANT:

To avoid overflows, **DO NOT** start the brew cycle unless an **EMPTY** satellite is in place under the brew chamber.

NOTE: The brew can be cancelled at any time by pressing the **STOP** switch.

NOTE: **DO NOT** change the VOLUME SELECT switch during a brew. This will disrupt the brew cycle.



CAUTION: Burn Hazard

Basket and contents are hot to the touch and may cause burns on contact.



OPERATING INSTRUCTIONS (continued)

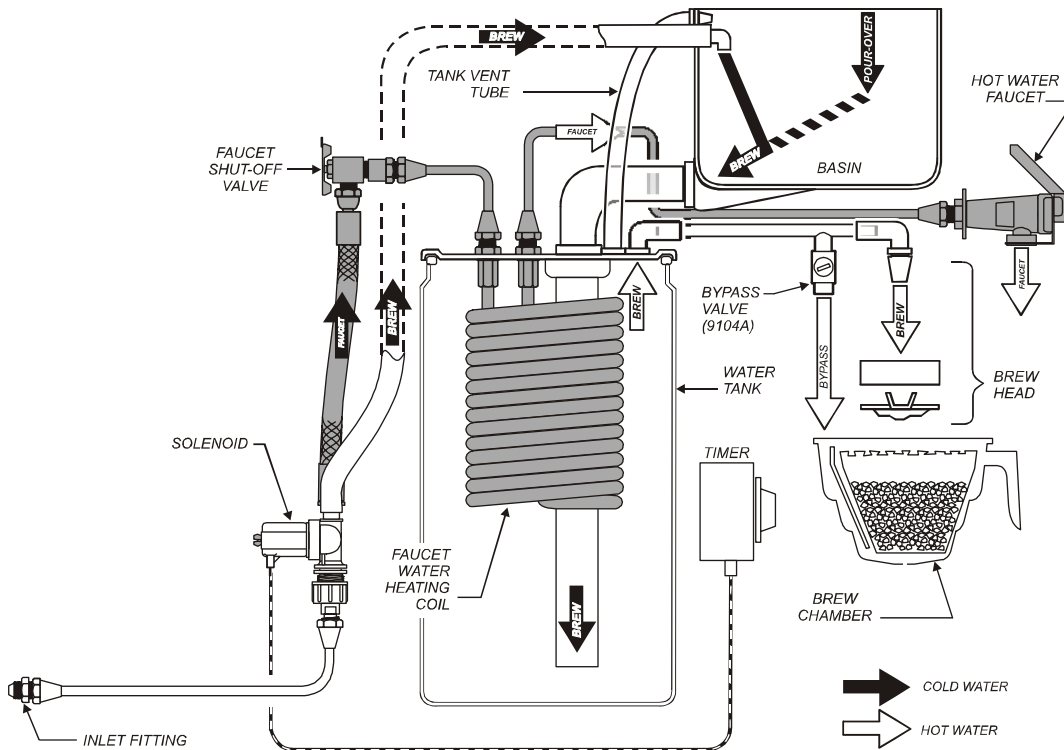

Fig. 7 Water Flow Diagram

The time the BREW SOLENOID is open is controlled by the TIMER in response to the position of the VOLUME SELECTOR switch.

The BYPASS is an adjustable flow control valve. It is adjusted to taste for 1 and 1-1/2 gallon brews in Model 9104A

NOTE: Use of the faucet will not affect the volume of water delivered for a brew. However, overuse of the faucet during a brew may lower the temperature of the brew water.

BREW & BYPASS

This brewer is a standard displacement brewer with pour-over option.

For 9102A there is no bypass. Water admitted into the hot water tank by the BREW SOLENOID will displace a like amount of heated water through the brew head, brew chamber and into the satellite.

For 9104A, operation is identical to 9102A, except that a portion of the heated water is diverted around the grounds in the brew chamber by a BYPASS. Bypass water dilutes the brewed coffee, which, in the larger volumes, would otherwise be too strong.

HOT WATER FAUCET

Water for the hot water faucet is heated in a coil inside of the water tank. The faucet volume may be controlled by adjusting the FAUCET NEEDLE VALVE. Hot water is delivered at inlet line pressure and is approximately the same temperature as the brew water.

CLEANING INSTRUCTIONS

PROCEDURE: Clean Coffee Brewer

PRECAUTIONS: Turn POWER SWITCH OFF.
Allow brewer to cool.

FREQUENCY: Daily

TOOLS: Mild Detergent, Clean Soft Cloth or Sponge
Bristle Brush



CAUTION: Burn Hazard

Brewing and serving temperatures of coffee are extremely hot. Hot coffee will cause serious skin burns.

1. Turn POWER SWITCH OFF.
Allow brewer to cool.
2. Remove satellite.
3. Remove and empty brew chamber.
4. Remove spray disk and gasket from spray head
5. Wipe inside of spray head and area around spray head with a soft clean cloth or sponge moistened with clean water.
6. Wash spray disk in a sink using warm water and a mild detergent. A bristle brush may be used to clear clogged spray holes. Rinse spray disks with clean water and allow to air dry.
7. Wash brew basket in a sink using warm water and a mild detergent. A bristle brush may be used to clean around the wire racks and bypass channels. Rinse with clean water and allow to air dry. Be sure wire rack is properly installed.
8. Remove and drain the drip tray. Rinse in a sink under warm running water. Allow to air dry, then reinstall on brewer.
9. Wipe exterior of brewer and satellites with a soft clean cloth or sponge moistened with clean water.
10. Reinstall gasket INSIDE brew head, then reinstall spray disk.
11. Reinstall brew chamber.
12. Reinstall satellite.

Procedure is complete

IMPORTANT:

DO NOT use steel wool, sharp objects, or caustic, abrasive or chlorinated cleansers to clean the brewer, brew baskets or satellites.

DO NOT immerse or submerge satellites in water.

CLEANING INSTRUCTIONS (continued)



CAUTION: **Burn Hazard**

Brewing and serving temperatures of coffee are extremely hot. Hot coffee will cause serious skin burns.

IMPORTANT:

DO NOT use steel wool, sharp objects, or caustic, abrasive or chlorinated cleansers to clean the satellites.

PROCEDURE: Clean Satellite

PRECAUTIONS: Drain Satellite before Cleaning

FREQUENCY: Twice Weekly

TOOLS: Sight Glass Brush, Sanitizer
Soft Clean Cloth, Bucket

1. Remove and drain satellite.
2. Place 1 packet of Sanitizer into 2-1/2 gallons of warm tap water. Pour approximately 1 gallon of sanitizer solution into each satellite. Allow to stand for 2 minutes.
3. Remove the shield cap (large vent) on top of the sight glass.

NOTE: It is not necessary to remove the sight glass unless it is broken and replacement is required.
4. Run the sight glass brush up and down through the sight glass at least 10 times.
5. Reinstall and tighten the shield cap.
6. Drain sanitizer solution from satellite into the bucket.
7. Disassemble faucet. Brush clean with sanitizer solution. Reassemble faucet.
8. Install satellite on brewer.
9. Rinse satellites: With an empty brew chamber in place, press the BREW key and run 1 full cycle into satellite.
10. Drain water from satellites.

Procedure is complete

TROUBLESHOOTING SUGGESTIONS		
SYMPTOM	POSSIBLE CAUSE	SUGGESTED REMEDY
Will not heat or brew (no lights)	Brewer not plugged in or circuit breaker tripped	Reconnect brewer to electric power Reset circuit breaker
	Main power switch off or damaged	Check. Turn main power switch on. Replace if needed
Will not brew	Brew switch damaged	Check. Replace if needed
	Timer damaged	Check. Replace if needed
	Volume selector switch damaged	Check. Replace if needed
Brewer fails to heat	Tank heat switch off	Turn tank heat switch on
	Hi-limit tripped	Allow to cool, reset hi-limit
	Thermostat out of adjustment or damaged	Check. Adjust or replace as needed
Brewer fails to stop brewing after STOP switch pressed	Switch not pressed long enough or firmly enough	Switch must be pressed firmly for at least 1 second
	Stop Brew switch damaged	Check. Replace if needed
	Brew solenoid damaged or dirty	Check. Clean or replace as needed
Coffee overflows from brew chamber	Too much coffee or too fine a grind	Use proper amount and grind of coffee grounds per brew
	More than 1 filter paper or wrong type of filter paper used	Use 1 genuine Bloomfield filter paper per brew
	Timer out of adjustment or damaged	Check time. Adjust or replace as needed
	Wire rack missing from brew chamber	Check. Replace if needed
Insufficient brew volume (all volumes)	Low inlet water pressure	Other appliances on water line may be robbing pressure. Brewer should be on dedicated water line
	Inlet or valve strainer plugged	Clean strainer
	Timer out of adjustment	Adjust time
	Timer damaged	Check. Replace if needed
Ready light does not glow	Light damaged	Check. Replace if needed
Poor spray pattern from spray disk	Spray disk holes plugged	Check. Clean as needed
	Gasket missing or improperly installed	Reinstall gasket inside brew head
Poor coffee quality	Keep brewer and satellites clean. Install a taste and odor filter in water supply, and replace cartridges regularly. Use a quality coffee with a consistent roast. Use proper grind and amount of coffee per brew.	

SERVICING INSTRUCTIONS



CAUTION: SHOCK HAZARD

Disconnect brewer from electric power before opening any access panel.

Note position of any wires or hoses before removing them from a panel.

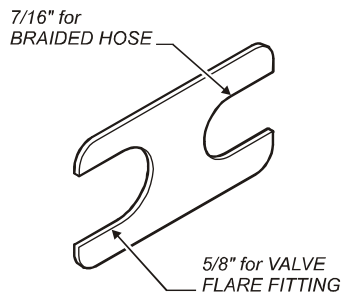

P/N 86660 Braided Hose Wrench

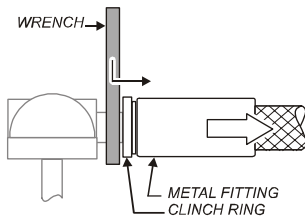
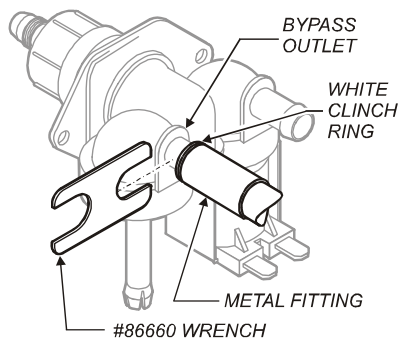

SLIDE WRENCH BETWEEN
VALVE AND HOSE FITTING
PRESS CLINCH RING TOWARD
METAL FITTING TO RELEASE

Wrench for Faucet Tubing

ACCESS PANELS

TOP PANEL is attached with two screws at the rear and a lip at the front.

TOP REAR PANEL is attached with four screws.

BASIN sets in the body. After disconnecting three hoses, it may be lifted out.

TIMER ACCESS and HI-LIMIT ACCESS PLUGS may be pried out with a thin flat blade screwdriver.

FRONT PANEL is attached with four screws.

SATELLITE WARMER PANEL is held by two spring clips. After removing the front panel, slide the warmer panel forward approximately 1/2" to release.

SATELLITE BRACKET is attached with two screws

BOTTOM PANEL is attached with six screws.

LEGS screw into the bottom panel.

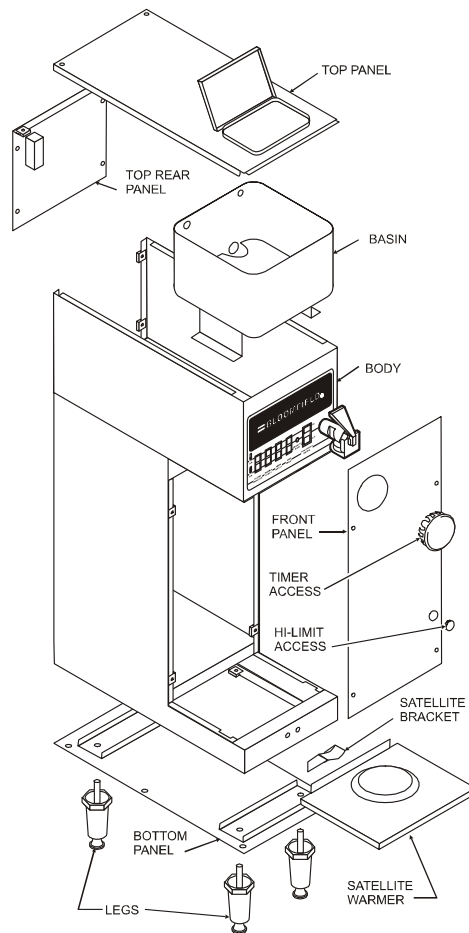

SERVICING INSTRUCTIONS (continued)

TEMPERATURE ADJUSTMENT

PRECAUTIONS: Disconnect brewer from electric power.
Allow brewer to cool.

FREQUENCY: As required to adjust delivered volume

TOOLS: Phillips head screwdriver



CAUTION: SHOCK HAZARD

Live electrical circuits are exposed during this procedure. Use care to avoid uninsulated electrical connectors.

Adjustments to be performed by qualified technician only.

NOTE:
1/8 turn = approx 10°F (5.5°C)

1. Press HEATER ON/OFF switch to *OFF*. Turn POWER switch on back of brewer *OFF*.
2. Remove TOP PANEL. Operating controls are accessible through the top panel only.
3. Remove vent tube from the tank cover and insert a thermometer of known accuracy.
4. Locate the CONTROL THERMOSTAT on the right side of the top housing:
Turn *CLOCKWISE* to increase temperature
Turn *COUNTER-CLOCKWISE* to decrease temperature
1/8 turn is equal to approximately 10°F change.
5. Turn POWER switch *ON*. Press TANK HEATER switch to *ON*.
6. Allow the brewer to come up to brewing temperature. When *READY-TO -BREW* light comes on, check temperature on thermometer. Readjust thermostat as necessary.

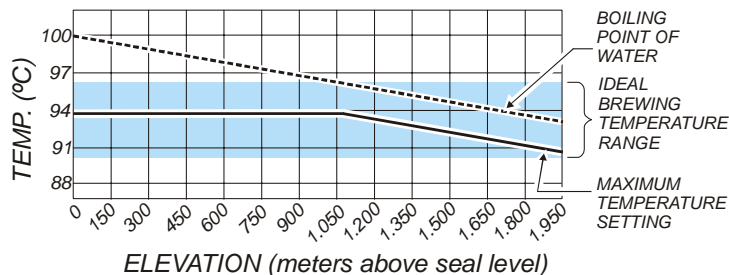
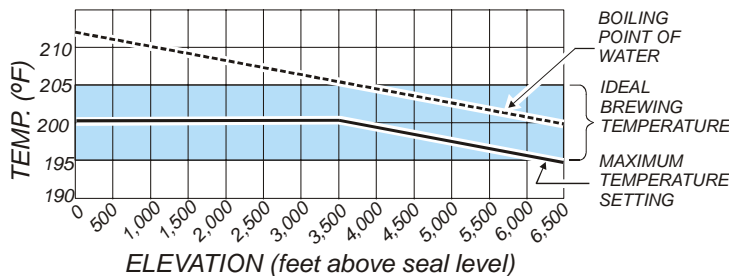
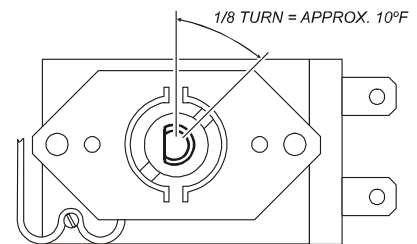

7. When desired temperature is achieved, remove thermometer, replace vent tube and reinstall top panel.

Procedure is complete

SERVICING INSTRUCTIONS (continued)

Adjustments to be performed by qualified technician only.

NOTE:

Brewer is pre-adjusted to deliver 1/2, 1 and/or 1-1/2 gallons of coffee at a water pressure of 50 p.s.i. Use this procedure to adjust the delivered volume to suit local conditions.

Adjust only in small increments to avoid large volume variations. Recommend knob be turned no more than one mark on the dial plate at a time. Moving the dial one mark will change delivered volume by approximately 6 oz.

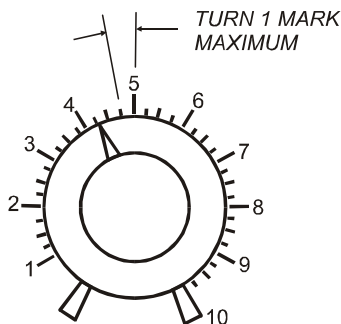

BREW TIMER ADJUSTMENT

PRECAUTIONS: None

FREQUENCY: As required to adjust delivered volume

TOOLS: Small flathead screwdriver
Satellite or other container to calibrate volume

1. Press TANK HEATER switch to *OFF*.
2. Remove TIMER ACCESS COVER on front panel. Press VOLUME SELECTOR to 1 GAL position.
3. Install an empty satellite and empty brew chamber.
4. Press START BREW switch. Brew should deliver 1 gallon (128 fl. oz.). If adjustment is necessary, turn TIMER knob:
Turn *CLOCKWISE* to increase time;
Turn *COUNTER-CLOCKWISE* to decrease time.
Test after each adjustment. Be sure to empty satellite before each test.
5. Turn TANK HEATER switch *ON*.
6. Allow the brewer to come up to brewing temperature, then perform a test brew. Check delivered volume. Readjust as necessary.
7. Reinstall TIMER ACCESS COVER.

When desired volume is achieved, procedure is complete.

SERVICING INSTRUCTIONS (continued)

BYPASS ADJUSTMENT (9104A ONLY)

PRECAUTIONS: Disconnect brewer from electric power.
Allow brewer to cool.

FREQUENCY: As required to adjust for change in delivered volume, or to taste.

TOOLS: Phillips head screwdriver
Stubby flathead screwdriver
Provided wire gauge set

1. Press TANK HEATER switch to *OFF*. Disconnect brewer from electrical power.
2. Remove SATELLITE, BREW CHAMBER, TOP PANEL and BASIN.
3. Turn bypass adjustment screw several turns counter-clockwise. Insert and hold appropriate gauge fully into bypass valve from the outside of the brewer.
4. Turn bypass adjustment screw clockwise until the resistance of the adjuster contacting the gauge is felt.
5. Release the gauge set. Turn bypass adjustment screw counterclockwise slowly until gauge set fall out of the valve.
6. Reassemble brewer and perform a 1 gallon brew and sample for taste. Adjust from this point to achieve desired taste:
 - a. Repeat steps 1 and 2.
 - b. Turn bypass adjustment screw counterclockwise to decrease coffee strength (increase dilution); or , clockwise to increase coffee strength (decrease dilution).
7. Perform BREW TIMER ADJUSTMENT to insure delivery of 128 oz. in 1 gallon mode.

Procedure is complete



CAUTION:
SHOCK HAZARD

Disconnect brewer from electric power before opening the top panel.

The brewer is shipped from the factory pre-set for 25% bypass. This adjustment must never be made unless the brewer is installed on a soft water line, or a change in coffee strength is required.

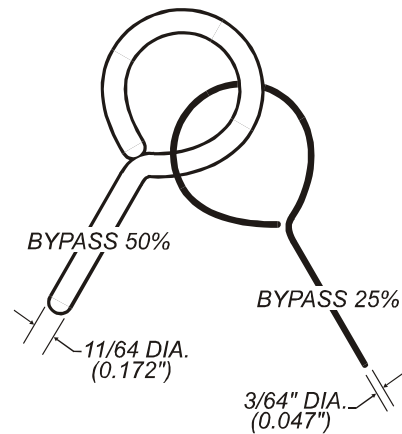

Bypass Gauge Set

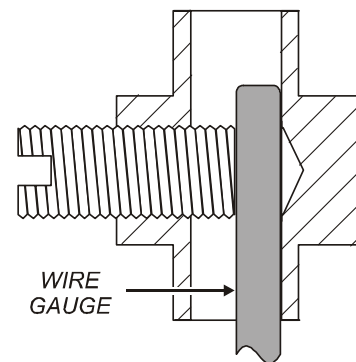

Bypass Adjustment

SERVICING INSTRUCTIONS (continued)



CAUTION: CHEMICAL BURN HAZARD

Deliming chemicals are caustic. Wear appropriate protective gloves and goggles during this procedure.

Never siphon deliming chemicals or solutions by mouth.

This operation should only be performed by qualified and experienced service personnel.

IMPORTANT: DO NOT spill, splash or pour water or deliming solution into or over any internal component other than the inside of the water tank.

IMPORTANT: DO NOT allow any internal components to come into contact with the deliming solution. Take care to keep all internal components dry.

NOTE: Repeat steps 4 and 7 as required to remove all build-up.

PROCEDURE: Delime the Water Tank

PRECAUTIONS: Disconnect brewer from electric power. Allow brewer to cool.

FREQUENCY: As required (Brewer slow to heat)

TOOLS: Deliming Solution
Protective Gloves, Goggles & Apron
Mild Detergent, Clean Soft Cloth or Sponge
Bristle Brush, Bottle Brush
Large Sink (or other appropriate work area)

-
1. Disconnect brewer from the electrical supply.
 2. Remove the brewer top panel, then remove the tank lid assembly. Do not disconnect the tank assembly at this time.
 3. Siphon all water from the hot water tank.
 4. Mix 2 gallons of deliming solution according to the manufacturer's directions. Carefully pour the deliming solution into the water tank. Lower the lid assembly back onto the tank. Allow to sit for 30 minutes, or as directed by the chemical manufacturer.
 5. At end of soaking period, reconnect brewer to electrical power. Install the brew chamber without filter paper or grounds. Place an empty satellite under the brew chamber. Force a 1-1/2 gallon brew:
 - a. Press the 1-1/2 gallon key
 - b. Press the brew key, then press and hold the brew key until a brew is initiated.Empty the satellite and repeat for the other side.
 6. Disconnect brewer from electrical power and allow to cool.
 7. Remove lid assembly from tank.
 - a. Using a stiff bristle brush, scrub internal components to remove lime and calcium build-up.
 - b. Thoroughly rinse internal components of lid assembly with clear water.
 - c. Store lid assembly in a safe location.
 8. Using a stiff bristle brush, scrub exposed portions of the heating element and the inside surfaces of the tank to remove lime and calcium build-up.
 9. Siphon all solution from the tank.

SERVICING INSTRUCTIONS (continued)

10. Reinstall tank lid assembly into hot water tank. Make sure the lid gasket is properly in place, then reinstall the hold-down clamp.
11. Remove spray disks and gaskets. Rinse both brew heads with clean water. Using a stiff brush, scrub spray disk to remove any lime or calcium build-up. Reinstall gaskets and spray disks.
13. Reconnect brewer to electrical supply .
14. Install the brew chamber without filter paper or grounds.
15. Place an empty satellite under the brew chamber. Run at least five 1 gallon brew cycles and discard all water generated at the end of each cycle. Repeat for the other side.
16. Rinse satellite with clean water. Reinstall empty satellite under brew chamber.

NOTE: Normally, silicone hoses do not need to be delimed. Should deliming hoses become necessary, Bloomfield recommends replacing the hoses.

Brewer is ready to use.

EXPLODED VIEW

PLUMBING COMPONENTS

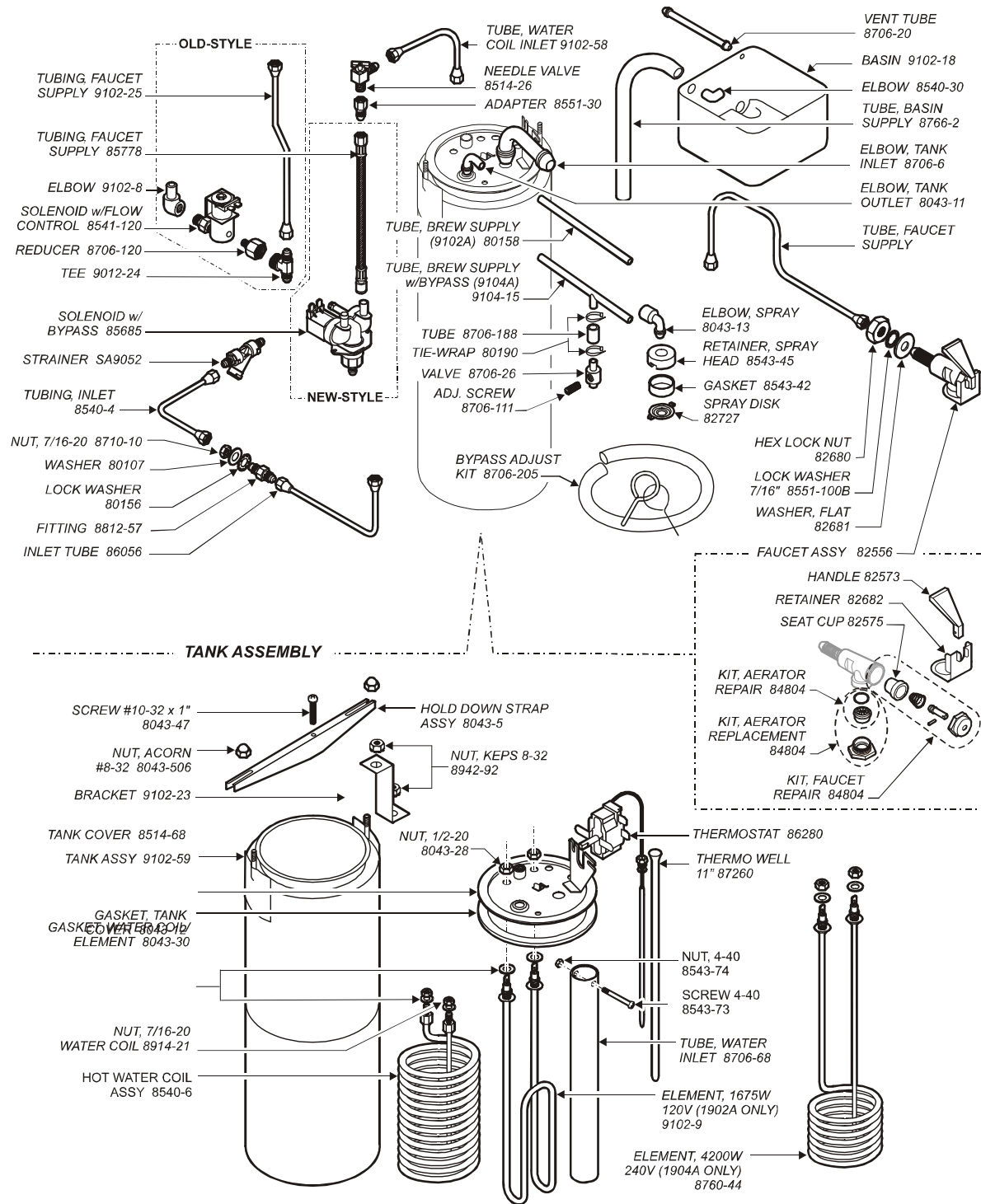

663 76061 Owners Manual for 9102A Single Satellite Brewer

ELECTRICAL COMPONENTS

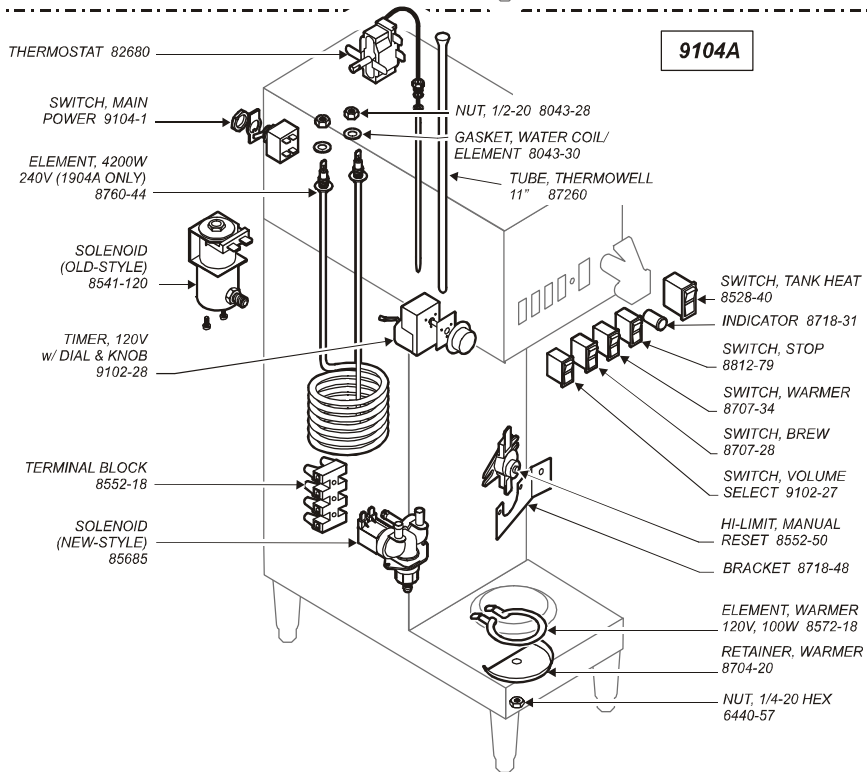
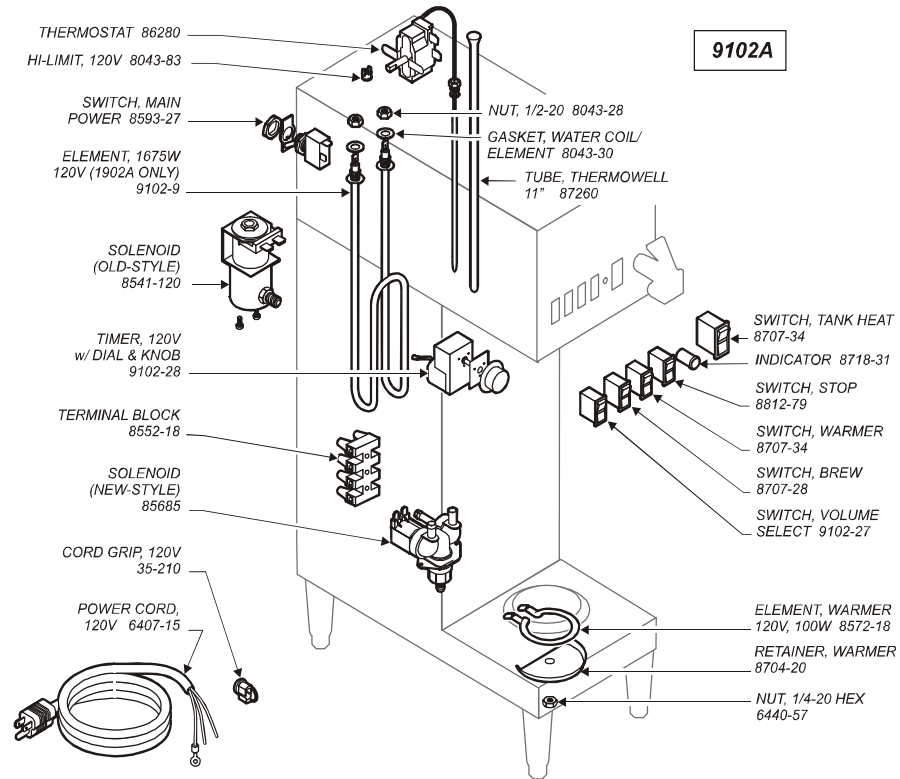

663 76061 Owners Manual for 9102A Single Satellite Brewer

EXPLODED VIEW ((continued))

CABINET & RELATED COMPONENTS

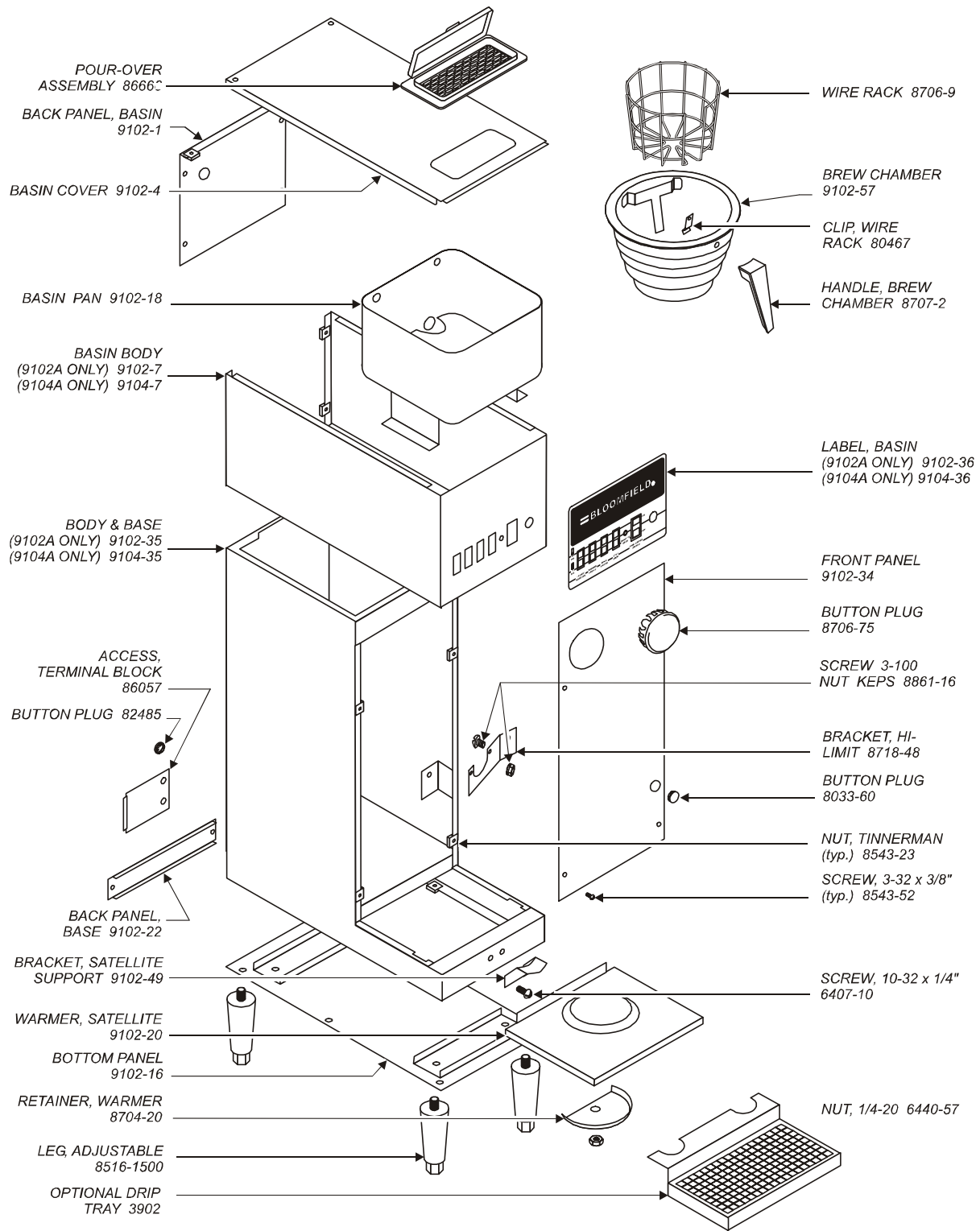

663 76061 Owners Manual for 9102A Single Satellite Brewer

SATELLITE ASSEMBLY 9105SS

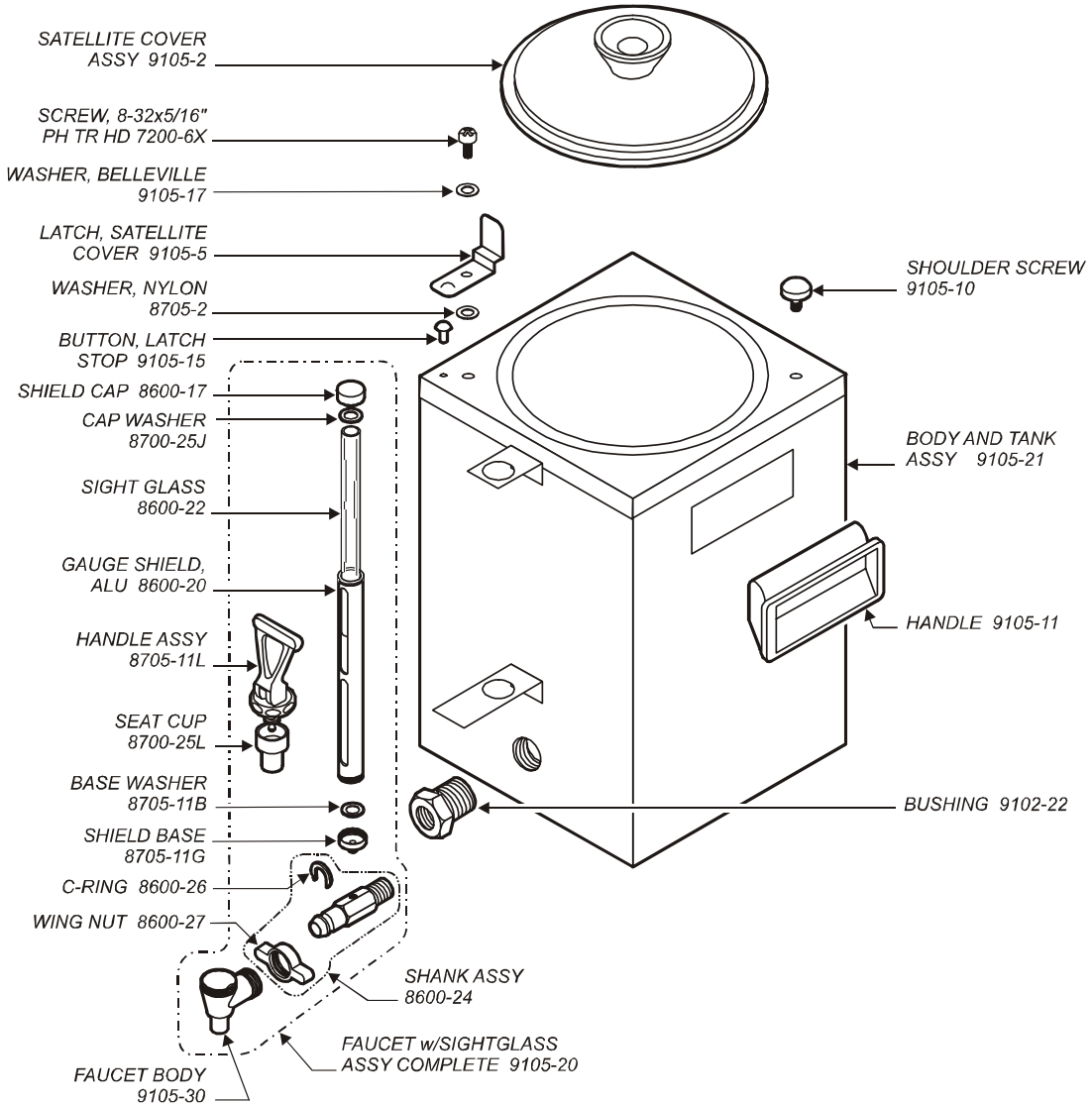

663 76061 Owners Manual for 9102A Single Satellite Brewer

SERVICE KITS

FAUCET REPAIR COMPONENTS

82680	Hex Lock Nut
8551-100B	7/16" Lock Washer
82681	Washer
82556	Faucet Assembly

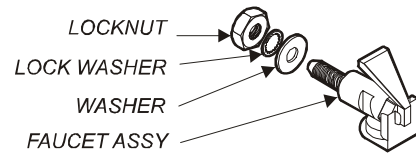

FAUCET REPAIR KITS

82573	Handle
82575	Seat Cup
82576	Faucet Repair Kit (Includes Handle, Seat Cup, Spring, Stem, Pin & Bonnet)
82682	Retainer Clip
84804	Aerator Replacement Kit (Includes O-Ring, Aerator Disk & Aerator Cap)
84870	Aerator Repair Kit (Includes O-Ring & Aerator Disk)

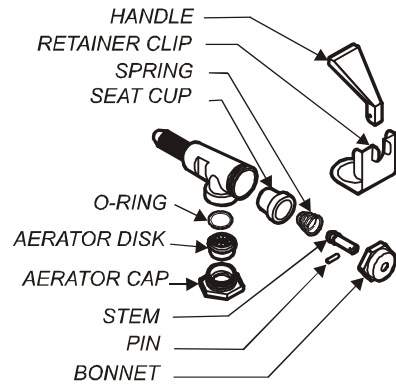

SOLENOID REPAIR KITS

85685	Solenoid, Complete, with Bypass
85218	Inlet Fitting Kit (cap, inlet fitting, washer & strainer)
85219	Inlet Strainer

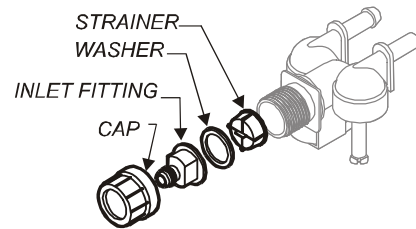

WIRING DIAGRAMS

MODEL 9102A

VOLTS	120 VOLTS 60 Hz
WATTS	1775 WATTS
AMPS	15 AMPS

p/n 72162 Rev. C

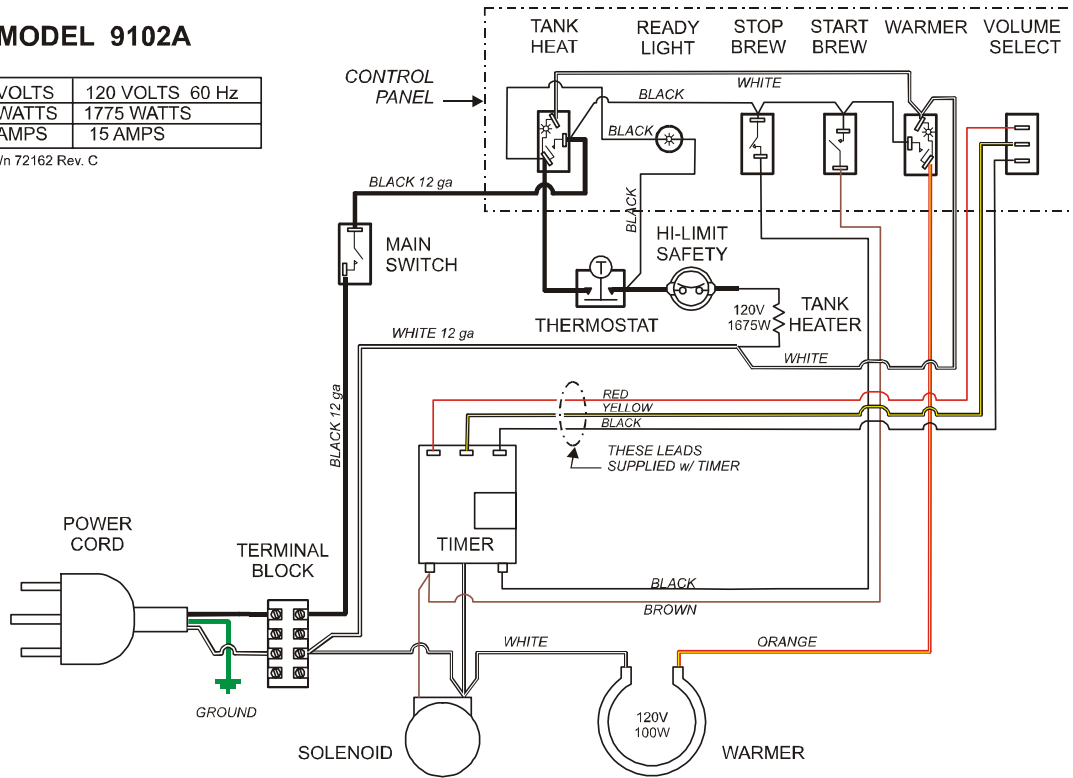

MODEL 9104A

VOLTS	115/230 VOLTS 60 Hz 1 ϕ
WATTS	4325 WATTS
AMPS	20 AMPS

p/n 71392 Rev. A

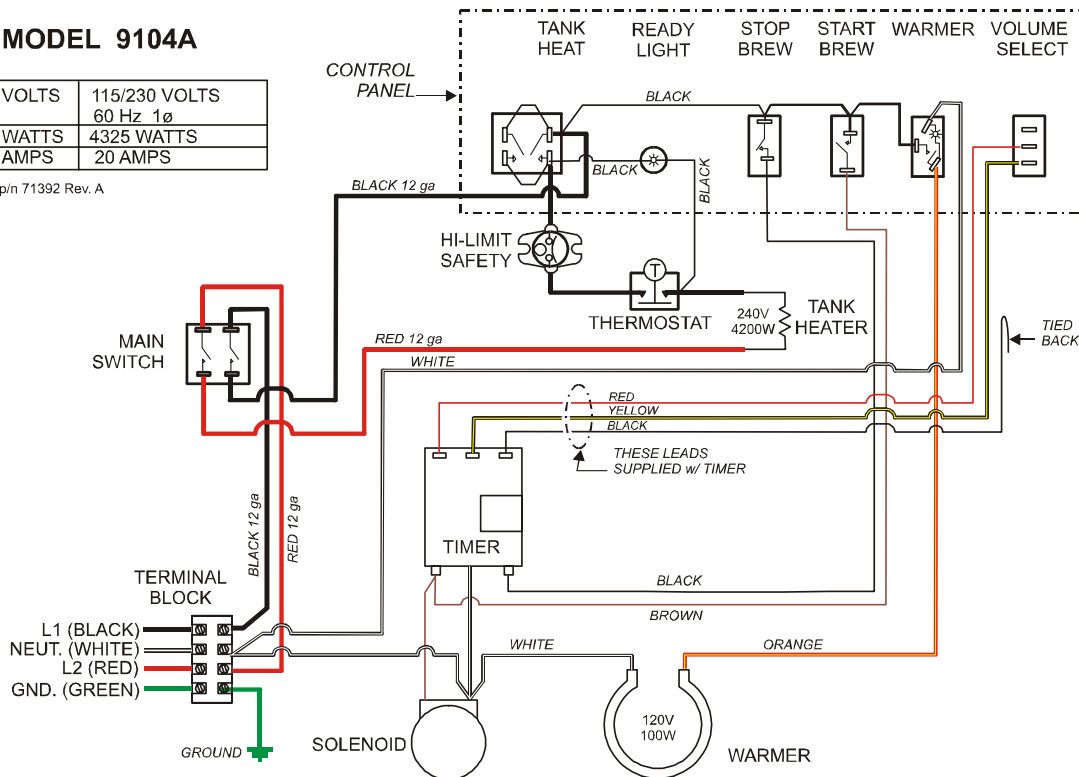

663 76061 Owners Manual for 9102A Single Satellite Brewer

CFESA

Commercial Food Equipment Service Association

Bloomfield Industries proudly supports CFESA
Commercial Food Equipment Service Association

SERVICE TRAINING - QUALITY SERVICE



CUSTOMER SATISFACTION



BLOOMFIELD

Bloomfield Industries, Inc.
Division of Carrier Commercial Refrigeration

In US and Canada

Telephone: 775-698-5700

Fax: 888-492-2783

Fax: 800-356-5142 (*for orders only*)

website: www.wellsbloomfield.com

PRINTED IN UNITED STATES OF AMERICA

Free Manuals Download Website

<http://myh66.com>

<http://usermanuals.us>

<http://www.somanuals.com>

<http://www.4manuals.cc>

<http://www.manual-lib.com>

<http://www.404manual.com>

<http://www.luxmanual.com>

<http://aubethermostatmanual.com>

Golf course search by state

<http://golfingnear.com>

Email search by domain

<http://emailbydomain.com>

Auto manuals search

<http://auto.somanuals.com>

TV manuals search

<http://tv.somanuals.com>