

BatteryLink® ACR

Automatic Charging Relay

with Auxiliary Battery Priority

PN 7611

Features

- Automatically combines batteries during charging and isolates batteries when discharging
- Optional Auxiliary Battery Priority connection shares the alternator charge with the Auxiliary battery longer allowing the use of the auxiliary loads for an extended period of time when the engine is running
- 120A Continuous rating to support high output alternators
- One tenth of the voltage drop of a battery isolator results in more fully charged batteries
- Dual sensing to manage multiple charge sources
- Robust, fully sealed assembly for reliability in environments with vibration and moisture
- Clip-on cover insulates terminal connections
- Easy to install
- Integrated LED indicates ACR status (LED is ON when batteries are combined)
- Optional remote LED output for indication of ACR status

LED Status Chart		
LED	Relay	Status
ON	Closed	Batteries Combined
OFF	Open	Batteries Isolated

Specifications	12V DC	24V DC
Continuous Rating	120A	120A
Intermittent Rating (5 min.)	210A	210A
Maximum Cable Size	1/0 AWG	1/0 AWG
Terminal Stud Size	3/8"-16 (M10)	3/8"-16 (M10)
Maximum Torque	140 in-lbs	140 in-lbs
Male Quick Connect Terminals	1/4" x .032"	1/4" x .032"

Relay Contact Position

Combine	(30 sec.)	13.6V DC	27.2V DC
Combine	(2 min.)	13.0 V DC	26.0V DC
Open Low	(30 sec.)	12.75V DC	25.5V DC
Open-Over Voltage Lockout		16.0V DC	32.0V DC

Auxiliary Battery Priority Optional Feature

Open Low	(30 sec.)	12.25V DC	24.5V DC
----------	-----------	-----------	----------

Regulatory

CE marked for Ignition Protection, Meets ISO 8846, UL 1500 and SAE J1171 external ignition protection requirements
Rated IP67—protected against immersion up to 1 meter for 30 minutes

Guarantee

Blue Sea Systems stands behind its products for as long as you own them. Find detailed information at www.blueseasystems.com/about. For customer service, call 800-222-7617.

Installation Instructions

Mounting

- To avoid corrosion to connecting wires and terminals, mount in a dry and protected location if possible. Avoid locations directly above the battery banks.

Electrical Connections

- The wiring diagrams illustrated on the back page represent common installations and are not meant to be a guide for wiring a specific vehicle.
- The 7611 ACR is not intended to carry starting currents. Use a battery switching system with a combine batteries/parallel function if batteries may need to be combined for emergency starting.
Caution: Disconnect battery connections before beginning the installation.

Use the Wire Size and Fuse Ratings chart on page 2 to select the appropriate wire sizes to prevent overheating the ACR.

Voltage Sensing

- The 7611 ACR will sense charging sources available on either battery bank.

Minimum connections for operation:

- Connect one battery bank to stud terminal **A**.
- Connect the other battery bank to stud terminal **B**.
- Connect the quick connect terminal marked **Ground** to the DC system ground through a ten to fifteen amp in-line fuse to prevent fault currents from flowing in this wire.

Optional connections:

1. Auxiliary Battery Priority

The 7611 ACR can be configured to allow batteries to remain “paralleled” down to a decreased “Open Low” voltage of 12.25/24.5V DC if desired. Enable this feature if you need to access some of your engine start battery’s stored energy for accessory loads. The feature can be configured for temporary use while the ignition is on, or permanently. Wiring permanently allows this device to also be used as a Low Voltage Disconnect (LVD) to prevent accidental and potentially damaging over-discharge of accessory batteries by disconnecting loads.

To enable temporary voltage override:

- Connect a wire from the quick connect terminal marked Aux. Battery Priority through an appropriately sized in-line fuse (1A to 10A) to a terminal or wire running from the ignition switch that is +12/24V DC while the ignition is on, and at 0V DC when ignition is off.

To enable permanent voltage override:

- Connect a wire from the quick connect terminal marked Aux. Battery Priority through an appropriately sized in-line fuse (1A to 10A) to a +12/24V DC source

2. Remote indicator lamp – mimics “COMBINED” LED on unit.

Appropriate 12/24V LEDs include Blue Sea Systems PNs 8033 (amber), 8171 (red), or 8172 (green).

To connect a remote LED indicator:

- Connect the red wire of the LED to a 12/24V positive source through a 2A inline fuse.
- Connect the yellow wire of the LED to the quick connect terminal marked **LED**.

Open/Close Cycling

- If your electrical system is configured with a charging source that cannot supply the full load current being drawn from the receiving batteries, an open/close cycling process can occur. If this cycling continues, the second battery bank could eventually discharge even though a charge source is present.

Recommended Installation Diagram

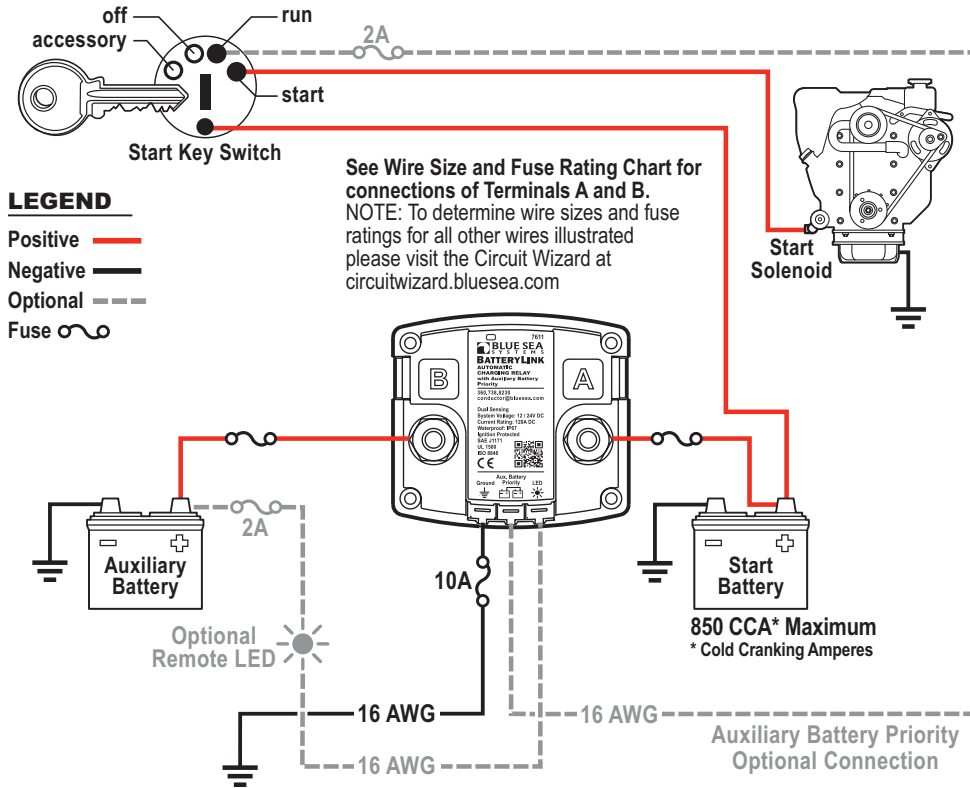

* This installation diagram shows a typical application only. Your application may differ. For further information, please go to www.bluesea.com and navigate to Resources/Application Briefs and Technical Briefs.

* Because the BatteryLink™ ACR is Dual Sensing, terminals A and B are interchangeable. ACR function will not be affected by reversal of the starting and house batteries versus the diagram.

* It is recommended that the ACR be connected directly to your battery positive terminals through appropriately sized fuses. Connecting in a different location such as a battery switch may affect accuracy because of voltage drop along current carrying conductors.

* If you are not knowledgeable about electrical systems, please consult an electrical professional for help with installation.

Wire Size and Fuse Ratings

Wire Size and Fuse Rating Chart (AWG)		
Charging Amps	Minimum Wire Size*	Fuse Rating
≤60	#6	75-90A
≤80	#4	100-125A
≤100	#2	150A
≤120	#1	175A

Wire Size and Fuse Rating Chart (Metric)		
Charging Amps	Minimum Wire Size*	Fuse Rating
≤50	10 mm ²	75-80A
≤70	16 mm ²	80-90A
≤90	25 mm ²	125-130A
≤110	35 mm ²	150A
≤120	50 mm ²	150-175A

* Larger wire sizes may be required to minimize voltage drop in long wire runs. For more information please use the Circuit Wizard at www.circuitwizard.bluesea.com

Dimension Drawings

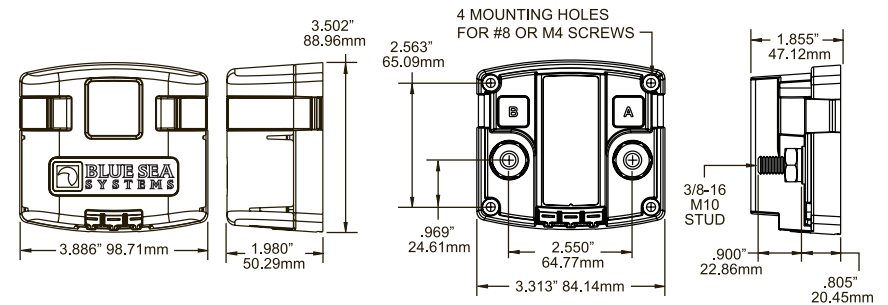

425 Sequoia Drive
Bellingham, WA 98226 USA
p 360.738.8230
p 800.222.7617 USA and Canada
f 360.734.4195
www.bluesea.com

980011740 Rev.002

Free Manuals Download Website

<http://myh66.com>

<http://usermanuals.us>

<http://www.somanuals.com>

<http://www.4manuals.cc>

<http://www.manual-lib.com>

<http://www.404manual.com>

<http://www.luxmanual.com>

<http://aubethermostatmanual.com>

Golf course search by state

<http://golfingnear.com>

Email search by domain

<http://emailbydomain.com>

Auto manuals search

<http://auto.somanuals.com>

TV manuals search

<http://tv.somanuals.com>