



COMMERCIAL ATMOSPHERIC GAS WATER HEATERS

FEATURING... installation-friendly *easy fit* dimensions, connections and controls!

Narrow or short, there's an

EZFIT
model just right for the job.



FIVE-YEAR LIMITED WARRANTY
the industry's finest commercial protection

- ◆ 75, 80, 90 and 100 gallon sizes
- ◆ 135,000 up to 199,000 BTU
- ◆ Natural gas or propane burners
- ◆ 120°F to 180°F adjustable digital thermostat
- ◆ Electronic ignition
- ◆ Automatic damper
- ◆ Water jet sediment reduction side inlet
- ◆ Clean out port
- ◆ NSF kit option
- ◆ 80% Thermal Efficiency



Turboflue[®]

heat exchanger

- ◆ Energy-Saving Turbofins conduct more heat into water.
- ◆ Robust single-flue design yields a stronger, more durable tank

All-American Product



This product is available from:

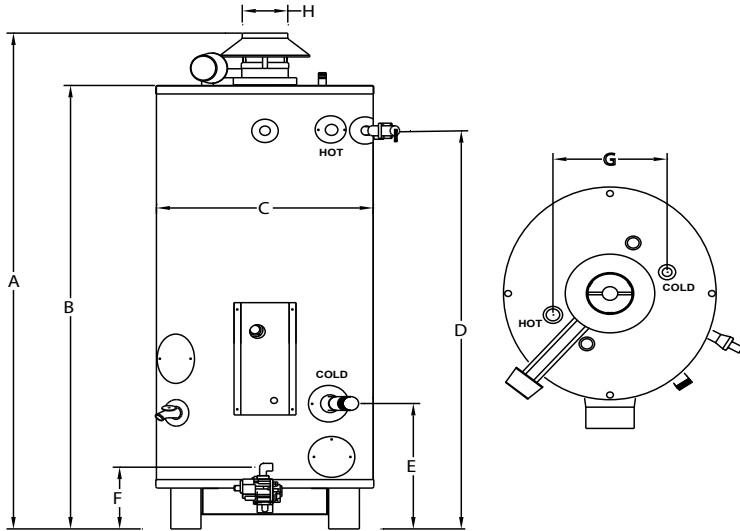

Model	Storage (GAL)	Rated Input (BTU/HR)	Recovery @ 100°F rise (GPH)	1ST HR. DEL. @ 100°F rise (GAL)	DIMENSIONS (INCHES)								SIDE WTR. CONN. DIA.	TOP INLET CONN. DIA.	TOP OUTLET CONN. DIA.	GAS CONN. DIA.	SHIPPING WEIGHT (LBS)
					A	B	C	D	E	F	G	H					
EZ 75-135N	67	135,000	130	183	73.25	65.5	26	58.25	20	9	16	6	1.5	1	1.5	0.5	410
EZ 80-156N	80	156,000	150	214	73.25	65.5	26	58.5	18	9	16	6	1.5	1	1.5	0.5	440
EZ 80-199N	80	199,000	191	255	73	65.25	28	58.5	18	9	16	6	1.5	1	1.5	0.5	500
EZ 90-199N	90	199,000	191	263	78	70.25	26	62.75	18	9	16	6	1.5	1	1.5	0.5	485
EZ 100-199N	100	199,000	191	271	70.75	63	31.5	54.75	18	9	19	6	1.5	1	2	0.5	655

For LP models change suffix "N" to "LP"

Working Pressure: 150 PSI (1034 kPa)

Test Pressure: 300 PSI (2068 kPa)

Standard Voltage required: 120V, 60Hz, 1P

For natural gas: manifold pressure = 3.5" w.c. (0.87 kPa); Inlet pressure range = 5 - 7" w.c. (1.25-1.74 kPa)

For propane gas: manifold pressure = 10" w.c. (2.49 kPa); Inlet pressure range = 12 - 14" w.c. (2.99-3.49 kPa)

T&P valve factory installed

All Bock products meet or exceed current ASHRAE standards

These products are design certified by UL (Underwriters Laboratories) and meet ANSI Z21.10.3 requirements for operation up to 180°F (82°C).

Approved for use as an automatic circulating tank water heater or automatic storage water heater.

Warning: Do not install on combustible flooring. Installation should be in accordance with all national and/or local codes. In the absence of local codes, refer to NFPA 54 or ANSI Z21.10.3

Caution: The recommended maximum hot water temperature setting for normal residential use is 120°F (49°C). Bock recommends a tempering valve or anti-scald valve be installed and used according to the manufacturer's directions to prevent scalding.



www.bockwaterheaters.com
110 South Dickinson Street, Madison, Wisconsin 53703
Toll Free 800.794.2491 • Phone 608.257.2225 • Fax 608.257.5304



80018 Rev 6/08

Free Manuals Download Website

<http://myh66.com>

<http://usermanuals.us>

<http://www.somanuals.com>

<http://www.4manuals.cc>

<http://www.manual-lib.com>

<http://www.404manual.com>

<http://www.luxmanual.com>

<http://aubethermostatmanual.com>

Golf course search by state

<http://golfingnear.com>

Email search by domain

<http://emailbydomain.com>

Auto manuals search

<http://auto.somanuals.com>

TV manuals search

<http://tv.somanuals.com>