

# Applications manual

For tankless and point of use water heaters



**BOSCH**

## **Table of Contents**

<b>1 Introduction</b>	<b>3</b>
<b>2 Bosch Water Heating Models</b>	<b>3</b>
2.1 Sizing tankless water heaters	4
2.2 Bosch GWH 715 ES	6
2.3 Bosch GWH C 800 ES	7
2.4 Outdoor Installation for GWH 715 ES and GWH C 800 ES	8
2.5 Bosch GWH 345 ESR	9
2.6 Bosch GWH 450 ESR	10
2.7 Bosch GWH 425 EF	11
2.8 Bosch GWH 425 HN	12
2.9 Bosch GWH 425 PN	13
2.10 Bosch GWH 260 PN	14
2.11 Powerstream Pro RP17PT, RP27PT	15
2.12 Powerstream Pro RP1P, RP2P, RP3P, RP7P, RP9P, RP12PT	16
2.13 Ariston Pro GL2.5Ti, GL4Ti, GL8Ti	17
<b>3 Domestic Water Heating Applications</b>	<b>18</b>
3.1 Point-of-use applications	18
3.2 Whole house applications	22
<b>4 High Volume Potable Water Heating</b>	<b>26</b>
4.1 Parallel unit applications	26
4.2 Cascade unit applications	28
4.3 External storage tank loading applications	29
<b>5 Open Loop Space Heating</b>	<b>32</b>
5.1 External storage tank	32
5.2 Indirect tank applications	42
<b>6 Maintenance Drawings</b>	<b>44</b>
6.1 Descaling procedure	44
6.1 Descaling procedure diagram	45

## **1 Introduction**

The Bosch Applications Manual is intended to present some of the most common applications of the Bosch line of tankless and point of use water heaters. Application drawings are shown with both piping and corresponding electrical schematics where applicable. Auxiliary equipment depicted does not necessarily represent any one manufacturer or specific model number. There are a wide variety of techniques, practices and piping strategies possible when installing water heating appliances. It is the responsibility of the installing contractor to determine the most suitable arrangement for the application.

Although this manual covers many common applications for our products, system possibilities are virtually endless. Should you encounter an application that is not covered in this manual or have any questions regarding any of its content, we encourage you to contact your local sales representative or us directly at Bosch Water Heating.

This is not a substitute for any of the product's installation manuals. All specifications subject to change.

**Installation must conform with local codes or, in the absence of local codes, the National Fuel Gas Code ANSI Z 223.1/NFPA 54. In Canada: Installation must conform with CGA B149.(1,2) INSTALLATION CODES and/or local installation codes.**

## **2 Bosch Water Heating Models**

This section describes the water heaters available from Bosch Water Heating. The information given in each section provides a general overview to the specifications of that particular model. More detailed information is contained in the installation manuals. Download these manuals at [www.BoschPro.com](http://www.BoschPro.com).

## 2.1 Sizing tankless water heaters

### Definitions

- ▶ Major applications (2 GPM or more): Washing machine, bath tub, shower nozzle
- ▶ Minor applications(1.5 GPM or less): Low flow shower head, bathroom sink, kitchen sink

### Rule of thumb sizing

The tables below provide a general rule of thumb when sizing for most residential applications. For commercial applications or for a more detailed sizing method, use the instructions below in conjunction with the charts on the next page.

### Sizing by Chart

- ▶ Measure the flow rates at each fixture that will be used simultaneously and add them together. If only one application will be used at a time measure each fixture and use the maximum flow rate observed.

Rule of Thumb Sizing		
Model Number	Number of Major Applications	Number of Minor Applications
GWH 715 ES	2	0
GWH C 800 ES	2	1
GWH 425 HN/PN/EF	1	1
GWH 425 HN/PN/EF	0	2
GWH 260 PN	1	0
RP17PT	1	0
RP27PT	1	1

- ▶ Using a known volume container, record several fill times. Perform the calculation below to determine the flow rate (a one gallon fill time of 30 seconds is 2.0 gallons per minute (GPM)):

$$\text{Flow rate (GPM)} = \frac{\text{Volume (gallons)}}{\text{Fill time (sec)}} \times 60 \frac{\text{sec}}{\text{min}}$$

- ▶ Using a thermometer, measure the incoming water temperature. Subtract this temperature from the desired hot water temperature to get the degree rise. So, if the desired hot water temperature is 120F and incoming temperature is 55F, the desired degree rise is 65F.
- ▶ This example requires a flow rate of 2.0 GPM at a 65°F rise. The data point is shown on each graph. Since the demand is above the GWH 260 PN capacity, this application would require a GWH 425 HN/PN/EF gas tankless water heater. The electrical model used for this application would be the RP27PT electric tankless water heater.

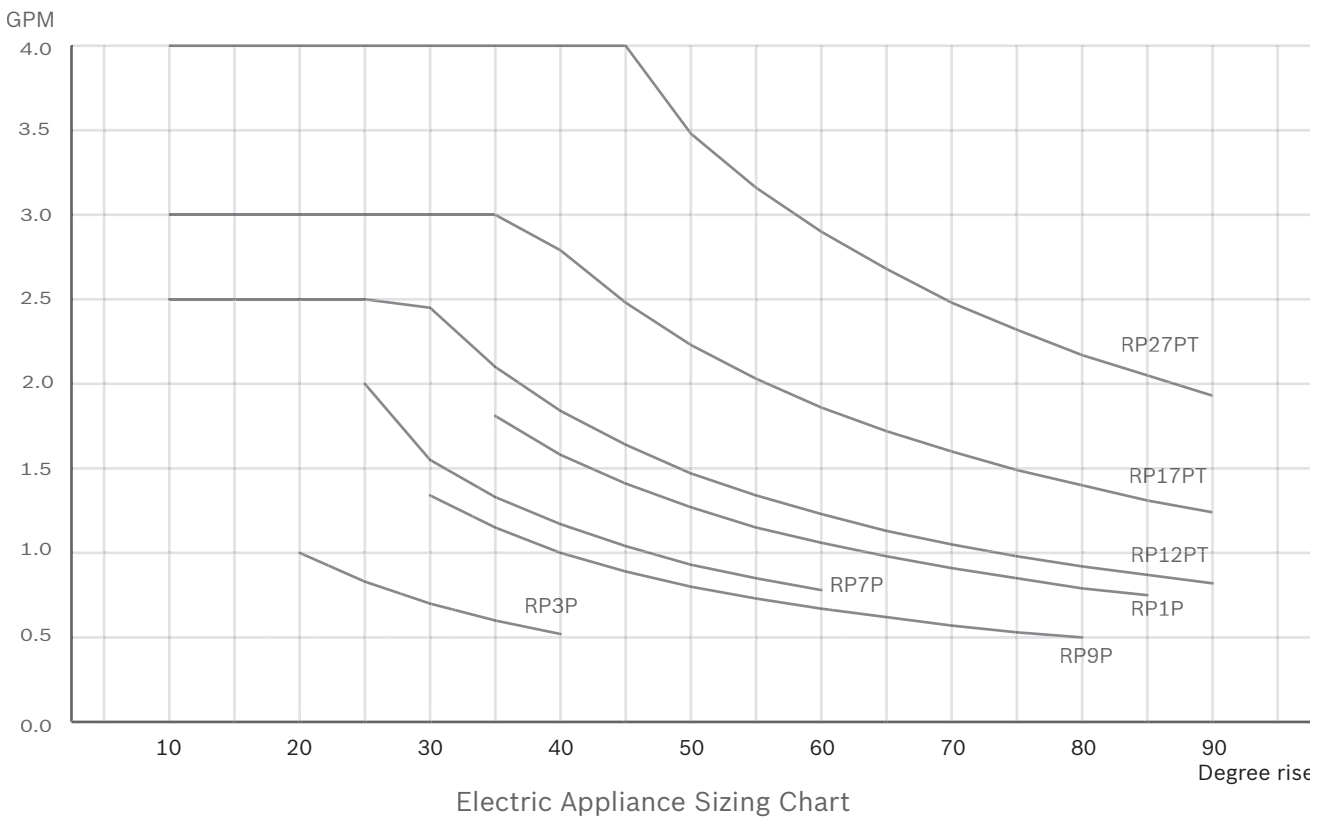
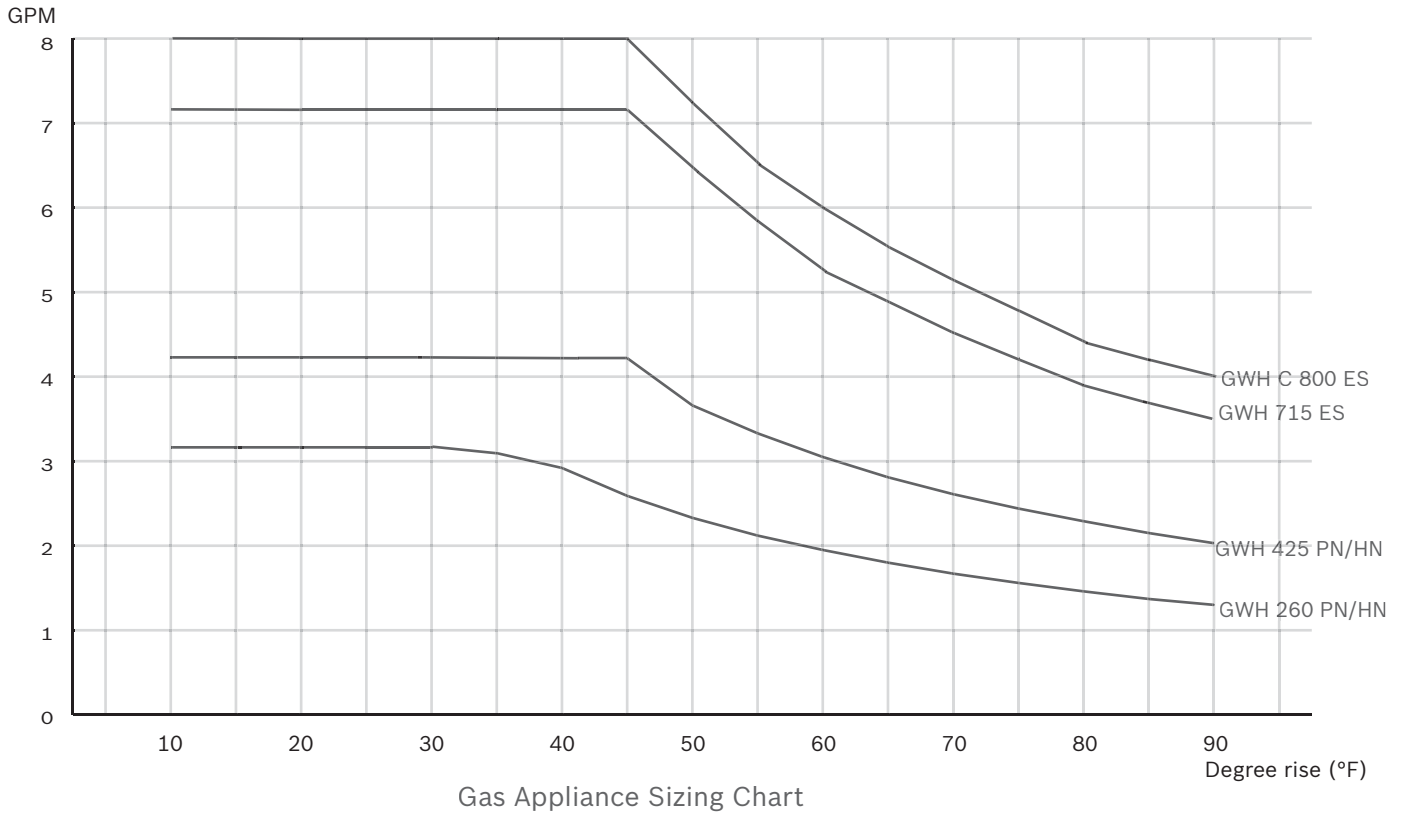

**Note:** Maximum flow rates dependant on site conditions

## 2.2 Bosch GWH 715 ES

### Features:

- ▶ Electronic ignition and built in power vent
- ▶ 82% thermal efficiency
- ▶ Vents vertically or horizontally with 3" or 4" stainless steel (AL29-4C)
- ▶ Direct vent room-sealed combustion
- ▶ Computerized temperature control – ensures temperature stability
- ▶ Model GWH 715 ES N for natural gas (NG) supply
- ▶ Model GWH 715 ES L for liquid propane (LP) supply
- ▶ 15-year warranty
- ▶ Qualifies for \$300 tax credit

### GWH 715 ES Technical Specifications

Gas input	Natural Gas: 19,900 - 199,000 BTU
	LP Gas: 19,900 - 199,000 BTU
Minimum flow to activate	0.65 gallons per minute (gpm)
Flow rates	45°F rise @ 7.2 gpm
	55°F rise @ 5.9 gpm
	65°F rise @ 5.0 gpm
	77°F rise @ 4.2 gpm
	90°F rise @ 3.6 gpm
Thermal Efficiency	NG: 82% LP: 82%
Dimensions	30½" h x 17⅞" w x 11¼" d
Weight	67 lbs.
Modulating gas valve	yes
Ignition	Electronic
Accessories	Outdoor kit (PTOK)
	Wireless Remote (TSTAT2)
	Tankless Link Cascading Kit (TLINK)
	Freeze Prevention Kit (8700400022) Water Filter Kit (8703305356)

### GWH 715 ES Installation Specifications

Gas connection	¾" Male NPT
Water connections	¾" Male NPT
NG gas pressure	Minimum: 4" W.C.
	Maximum: 14" W.C.
LP gas pressure	Minimum: 9" W.C.
	Maximum: 14" W.C.
Water pressure (Static)	Minimum: 30 PSI
	Minimum well pressure: 40 PSI
	Maximum: 150 PSI
Electrical supply	120VAC - plugs in
Venting	3" or 4" stainless steel (AL29-4C) direct vent room-sealed combustion

### GWH 715 ES Installation Clearances

Top (A)	12"
Front (B)	1"
Back	0"
Sides	1"
Floor (C)	12"

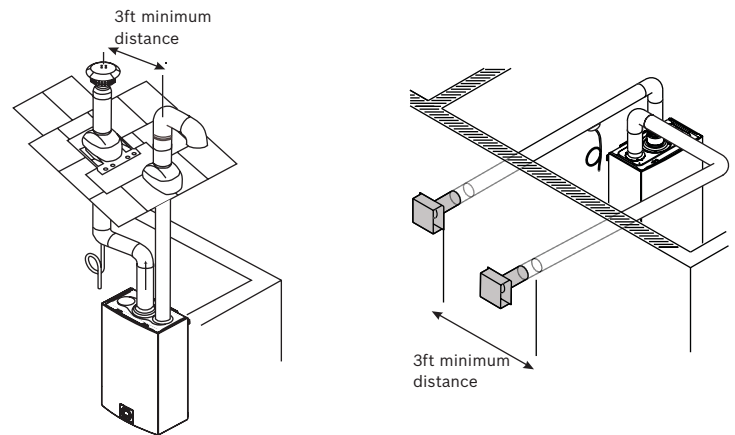
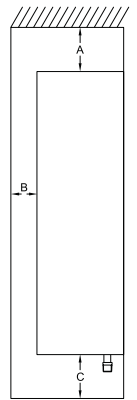

Fig. 1 Venting configurations

### Installation guidelines:

#### Venting:

- ▶ Must be 3" or 4" AL29-4C sealed stainless steel vent pipe.
- ▶ Slope horizontal runs up to termination ¼" per foot. The last horizontal section of exhaust vent pipe between last elbow and termination must slope down to the termination ¼" per foot.
- ▶ Do not combination vent with any other appliance.
- ▶ Install condensate drain where applicable.
- ▶ See manual for vent terminator clearances.

#### Gas piping:

- ▶ Heater will not function properly without adequate supply gas pressure.
- ▶ Any appliance connector should be ¾" minimum diameter

#### Plumbing:

- ▶ Install the included pressure relief valve and pipe to suitable drain.
- ▶ Minimum piping diameter is ¾".
- ▶ Do not solder directly to the bottom of the unit.
- ▶ Use unions to facilitate easy future maintenance.
- ▶ Use full port ball valves for isolation valves.
- ▶ Partially fill condensate drain tube loop (where applicable) with water prior to start up.

## 2.3 Bosch GWH C 800 ES

### Features:

- ▶ Electronic ignition and built in power vent
- ▶ Condensing technology with 92% thermal efficiency
- ▶ Vents vertically or horizontally with 3" or 4" PVC, CPVC or ABS (Schedule 40) vent pipe.
- ▶ Direct vent room-sealed combustion with concentric venting option
- ▶ Computerized temperature control – ensures temperature stability
- ▶ Model GWH C 800 ES N for natural gas (NG) supply
- ▶ Model GWH C 800 ES L for liquid propane (LP) supply
- ▶ 15-year warranty
- ▶ Qualifies for \$300 tax credit

### GWH C 800 ES Technical Specifications

Gas input	Natural Gas: 19,900 - 199,000 BTU LP Gas: 19,900 - 199,000 BTU
Minimum flow to activate	0.65 gallons per minute (gpm)
Flow rates	45°F rise @ 8.0 gpm 55°F rise @ 6.4 gpm 65°F rise @ 5.5 gpm 77°F rise @ 4.6 gpm 90°F rise @ 3.9 gpm
Thermal Efficiency	NG: 92% LP: 92%
Dimensions	30½" h x 17¾" w x 11¼" d
Weight	74 lbs.
Modulating gas valve	yes
Ignition	Electronic
Accessories	Outdoor kit (PTOK) Wireless Remote (TSTAT2) Tankless Link Cascading Kit (TLINK) Freeze Prevention Kit (8700400022) Water Filter Kit (8703305356) Concentric Termination Kit (BWH60L46)

### GWH C 800 ES Installation Specifications

Gas connection	¾" Male NPT
Water connections	¾" Male NPT
NG gas pressure	Minimum: 4" W.C. Maximum: 14" W.C.
LP gas pressure	Minimum: 9" W.C. Maximum: 14" W.C.
Water pressure (Static)	Minimum: 30 PSI Minimum well pressure: 40 PSI Maximum: 150 PSI
Electrical supply	120VAC - plugs in
Venting	3" or 4" PVC, CPVC, or ABS (Schedule 40) direct vent sealed combustion

GWH C 800 ES Installation Clearances	
Top (A)	12"
Front (B)	1"
Back	0"
Sides	1"
Floor (C)	12"

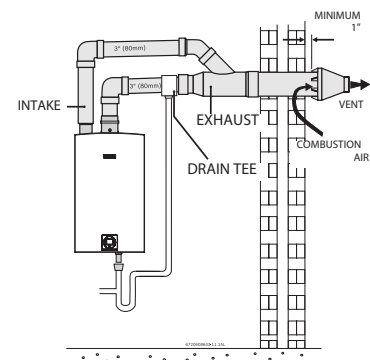
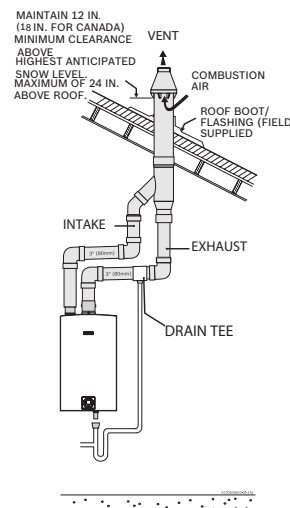
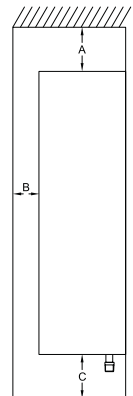

Fig. 1 Venting configurations

### Installation guidelines:

#### Venting:

- ▶ Must be 3" or 4" PVC, CPVC or ABS (Schedule 40) vent pipe.
- ▶ Attach drain for internal condensate siphon and dispose of according to local codes.
- ▶ Do not combination vent with any other appliance.
- ▶ Install an external condensate drain where applicable.
- ▶ See manual for vent terminator clearances.

#### Gas piping:

- ▶ Heater will not function properly without adequate supply gas pressure.
- ▶ Any appliance connector should be ¾" minimum diameter

#### Plumbing:

- ▶ Install the included pressure relief valve and pipe to suitable drain.
- ▶ Minimum piping diameter is ¾".
- ▶ Do not solder directly to the bottom of the unit.
- ▶ Use unions to facilitate easy future maintenance.
- ▶ Use full port ball valves for isolation valves.
- ▶ Partially fill condensate drain tube loop (where applicable)

## 2.4 Outdoor Installation for GWH 715 ES, and GWH C 800 ES

### Outdoor Kit (PTOK) installation:

- ▶ The installation of this outdoor kit (PTOK) is required when installing either of the above appliances outdoors
- ▶ Outdoor cap easily retrofits to these indoor models
- ▶ Outdoor kit comes with Freeze Prevention which must be installed
- ▶ Exterior water piping should be protected if freezing conditions could exist

### Minimum clearances:

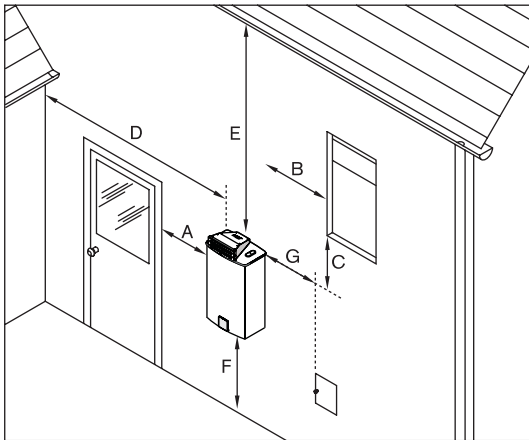

Ref.	Description	Min. distances
A	Directly below or adjacent to an opening; operable windows, doors and any fresh air openings	≥ 4 ft
B		
C		
D	From any adjacent wall	≥ 4 ft
E	Below a gutter, sanitary pipework, eaves or overhang	≥ 3 ft
F	Above ground	≥ 1 ft
G	From a gas meter or gas regulator	≥ 5 ft

### Outdoor Installation Clearances

Source: NFPA 54 National Fuel Gas Code  
ANSI Z223.1

### Installation on wood siding

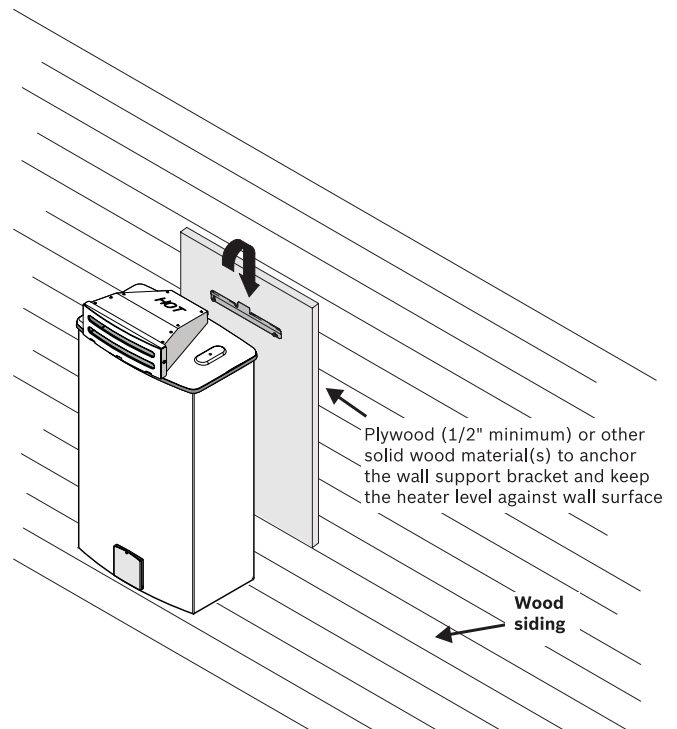

### Installation on vinyl siding:

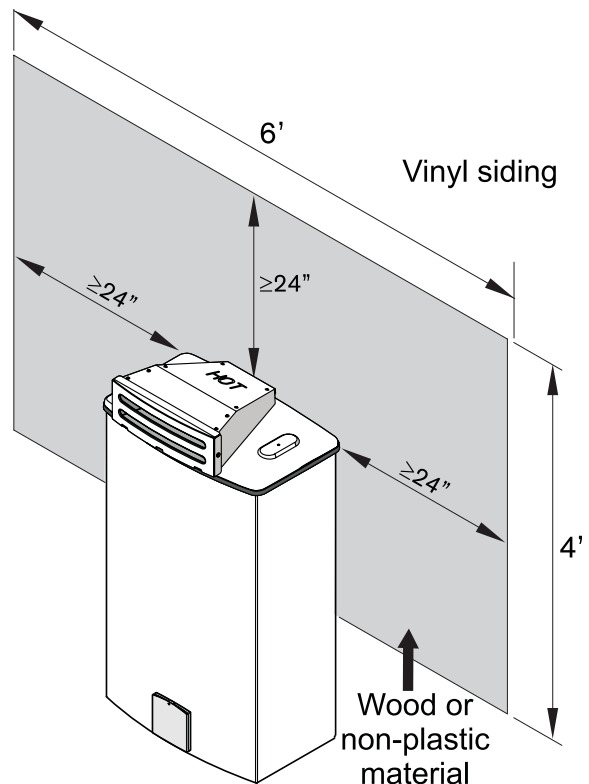



## 2.6 Bosch GWH 345 ESR

### Features:

- ▶ Specifically designed for recirculating applications
- ▶ Electronic ignition and built in power vent
- ▶ GWH 345 ESR thermal efficiency of 82%
- ▶ Vents vertically or horizontally with 3" stainless steel (AL29-4C)
- ▶ Direct vent room-sealed combustion
- ▶ Computerized temperature control – ensures temperature stability
- ▶ Model GWH 345 ESR N for natural gas (NG) supply
- ▶ Model GWH 345 ESR L for liquid propane (LP) supply
- ▶ 10-year warranty

### GWH 345 ESR Technical Specifications

Gas input	GWH 345 ESR: 32,000 - 95,000 Btu/h
Maximum flow rates	GWH 345 ESR: 3.5gpm @ 45°F rise
Thermal Efficiency	82%
Dimensions	27.5" h x 15.75" w x 11.75" d
Weight	47 lbs.
Modulating gas valve	yes
Ignition	Electronic

### GWH 345 ESR Installation Specifications

Gas connection	¾" Male NPT
Water connections	¾" Male NPT
NG gas pressure	Minimum: 5.5" W.C. Maximum: 14" W.C.
LP gas pressure	Minimum: 11" W.C. Maximum: 14" W.C.
Electrical supply	120VAC - plugs in
Venting	3" stainless steel (AL29-4C) direct vent room-sealed combustion

### GWH 450 ESR Installation Clearances

Top (A)	12"
Front (B)	1"
Back	0"
Sides	1"
Floor (C)	12"

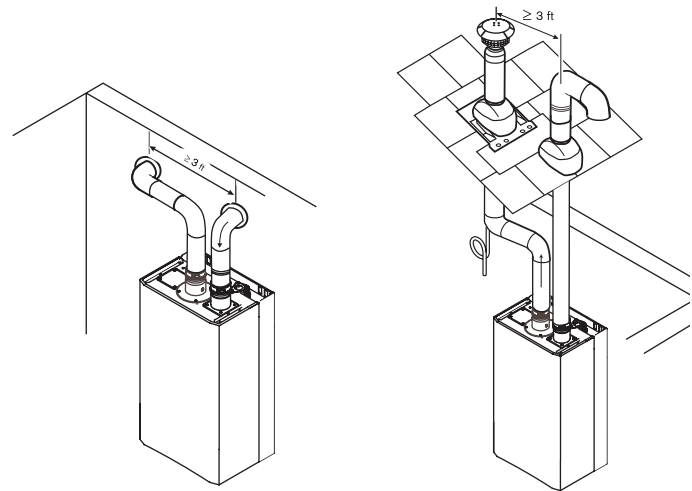
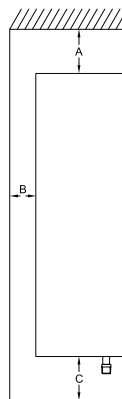

Fig. 1 Venting configurations

### Installation guidelines:

#### Venting:

- ▶ Must be 3" or 4" AL29-4C sealed stainless steel vent pipe.
- ▶ Slope horizontal runs up to termination ¼" per foot. The horizontal section between last elbow and termination must slope down to the termination ¼" per foot.
- ▶ Do not combination vent with any other appliance.
- ▶ **Always install an external condensate drain except when terminating horizontally with less than 3 feet of pipe.**
- ▶ See manual for vent terminator clearances.

#### Gas piping:

- ▶ Heater will not function properly without adequate supply gas pressure.
- ▶ Any appliance connector should be ¾" minimum diameter

#### Plumbing:

- ▶ Install the included pressure relief valve and pipe to suitable drain.
- ▶ Minimum piping diameter is ¾".
- ▶ Do not solder directly to the bottom of the unit.
- ▶ Use unions to facilitate easy future maintenance.
- ▶ Use full port ball valves for isolation valves.
- ▶ Partially fill condensate drain tube loop with water prior to start up.

## 2.6 Bosch GWH 450 ESR

### Features:

- ▶ Specifically designed for recirculating applications
- ▶ Electronic ignition and built in power vent
- ▶ GWH 450 ESR thermal efficiency of 81%
- ▶ Vents vertically or horizontally with 3" stainless steel (AL29-4C)
- ▶ Direct vent room-sealed combustion
- ▶ Computerized temperature control – ensures temperature stability
- ▶ Model GWH 450 ESR N for natural gas (NG) supply
- ▶ Model GWH 450 ESR L for liquid propane (LP) supply
- ▶ 10-year warranty

### GWH 450 ESR Technical Specifications

Gas input	GWH 450 ESR: 45,000 - 120,000 Btu/h
Maximum flow rates	GWH 450 ESR: 4.5gpm @ 45°F rise
Thermal Efficiency	81%
Dimensions	27.5" h x 15.75" w x 11.75" d
Weight	47 lbs.
Modulating gas valve	yes
Ignition	Electronic

### GWH 450 ESR Installation Specifications

Gas connection	¾" Male NPT
Water connections	¾" Male NPT
NG gas pressure	Minimum: 5.5" W.C. Maximum: 14" W.C.
LP gas pressure	Minimum: 11" W.C. Maximum: 14" W.C.
Electrical supply	120VAC - plugs in
Venting	3" stainless steel (AL29-4C) direct vent room-sealed combustion

### GWH 450 ESR Installation Clearances

Top (A)	12"
Front (B)	1"
Back	0"
Sides	1"
Floor (C)	12"

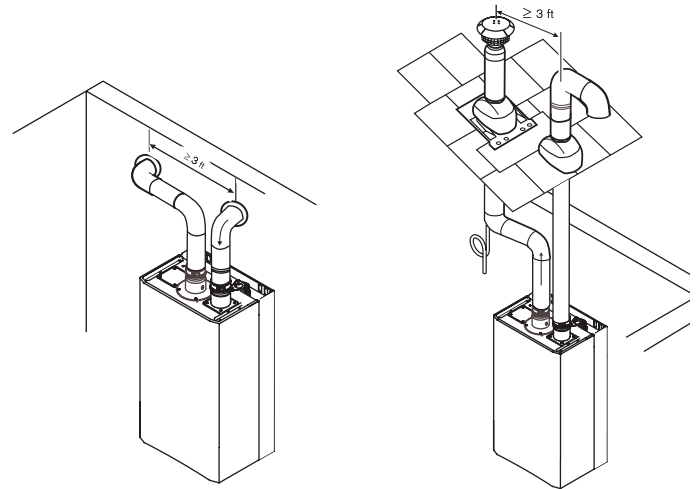
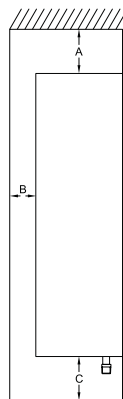

Fig. 1 Venting configurations

### Installation guidelines:

#### Venting:

- ▶ Must be 3" or 4" AL29-4C sealed stainless steel vent pipe.
- ▶ Slope horizontal runs up to termination ¼" per foot. The horizontal section between last elbow and termination must slope down to the termination ¼" per foot.
- ▶ Do not combination vent with any other appliance.
- ▶ **Always install an external condensate drain except when terminating horizontally with less than 3 feet of pipe.**
- ▶ See manual for vent terminator clearances.

#### Gas piping:

- ▶ Heater will not function properly without adequate supply gas pressure.
- ▶ Any appliance connector should be ¾" minimum diameter

#### Plumbing:

- ▶ Install the included pressure relief valve and pipe to suitable drain.
- ▶ Minimum piping diameter is ¾".
- ▶ Do not solder directly to the bottom of the unit.
- ▶ Use unions to facilitate easy future maintenance.
- ▶ Use full port ball valves for isolation valves.
- ▶ Partially fill condensate drain tube loop with water prior to start up.

## 2.7 Bosch GWH 425 EF

### Features:

- ▶ Electronic ignition and built in power vent
- ▶ Thermal efficiency of 82%
- ▶ Vents with 4" stainless steel or galvanized vent pipe
- ▶ Specifically designed for horizontal vent terminations
- ▶ Modulating gas valve – ensures temperature stability
- ▶ Model GWH 425 EF N for natural gas (NG) supply
- ▶ Model GWH 425 EF L for liquid propane (LP) supply
- ▶ 15-year warranty
- ▶ Qualifies for \$300 tax credit (LP only)

### GWH 425 EF Technical Specifications

Gas input	Natural Gas: 28,000 - 130,000 Btu/h LP Gas: 28,000- 125,000 Btu/h
Minimum flow to activate	0.5 gallons per minute (GPM)
Maximum flow rates	4.6 gpm @ 45°F rise
Thermal Efficiency	NG: 80% LP: 82%
Dimensions	29.75" h x 18.25" w x 8.75" d
Weight	44 lbs.
Modulating gas valve	yes
Ignition	Electronic

### GWH 425 EF Installation Specifications

Gas connection	½" Male NPT
Water connections	½" Male NPT
NG gas pressure	Minimum: 7" W.C. Maximum: 14" W.C.
LP gas pressure	Minimum: 11" W.C. Maximum: 14" W.C.
Electrical supply	120VAC - plugs in
Venting	4" stainless steel (AL29-4C) or 26 gauge galvanized

### GWH 425 EF Installation Clearances

Top (A)	12"
Front (B)	4"
Back	0"
Sides	4"
Floor (C)	12"

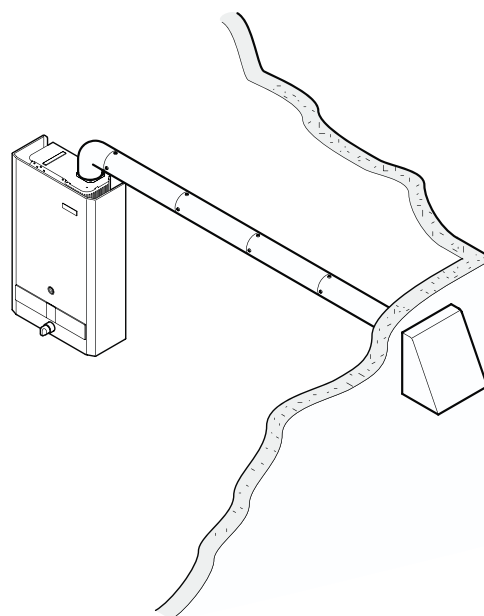
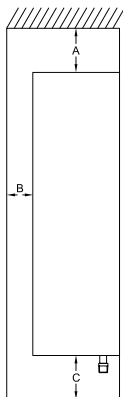

Fig. 1 Venting configurations

### Installation guidelines:

#### Venting:

- ▶ 4" AL29-4C sealed stainless steel or 26 gauge galvanized vent pipe.
- ▶ Slope horizontal runs up to termination ¼" per foot.
- ▶ Do not combination vent with any other appliance.
- ▶ See manual for vent terminator clearances.

#### Gas piping:

- ▶ Heater will not function properly without adequate supply gas pressure.
- ▶ Any appliance connector should be ¾" minimum diameter

#### Plumbing:

- ▶ Install the included pressure relief valve and pipe to suitable drain.
- ▶ Minimum piping diameter is ½".
- ▶ Do not solder directly to connections on the bottom of the unit.
- ▶ Use full port ball valves for isolation valves.

## 2.8 Bosch GWH 425 HN

### Features:

- ▶ Hydro-generated ignition
- ▶ 80% thermal efficiency
- ▶ Endless hot water for one major application at a time
- ▶ Venting: 5" double wall B-vent – natural draft
- ▶ Modulating gas valve – constant temperature at varying flow rates
- ▶ Model GWH 425 HN N for natural gas (NG) supply
- ▶ Model GWH 425 HN L for liquid propane (LP) supply
- ▶ 15-year warranty
- ▶ Qualifies for \$300 tax credit

### GWH 425 HN Technical Specifications

Gas input	Natural Gas: 30,735 - 117,000 BTU
	LP Gas: 30,735 - 117,000 BTU
Minimum flow to activate	0.6 gallons per minute (gpm)
Flow rates	45°F rise @ 4.2 gpm
	55°F rise @ 3.4 gpm
	65°F rise @ 2.9 gpm
	77°F rise @ 2.4 gpm
	90°F rise @ 2.1 gpm
Thermal Efficiency	NG: 80% LP: 80%
Dimensions	25.75" h x 16.75" w x 8.5" d
Weight	33 lbs.
Modulating gas valve	yes
Ignition	Hydro-generated
Accessories	Horizontal vent kit (AQ4) - power vent kit for horizontal venting

### GWH 425 HN Installation Specifications

Gas connection	¾" Male NPT
Water connections	¾" Male NPT
NG gas pressure	Minimum: 7" W.C.
	Maximum: 14" W.C.
LP gas pressure	Minimum: 11" W.C.
	Maximum: 14" W.C.
Water pressure (Static)	Minimum: 30 PSI
	Minimum well pressure: 40 PSI
	Maximum: 150 PSI
Electrical supply	120VAC - plugs in
Vertical venting	5" minimum diameter - natural draft
Horizontal venting	AQ4 horizontal vent kit required for horizontal terminations

### GWH 425 HN Installation Clearances

Top (A)	12"
Front (B)	4"
Back	0"
Sides	4"
Floor (C)	12"

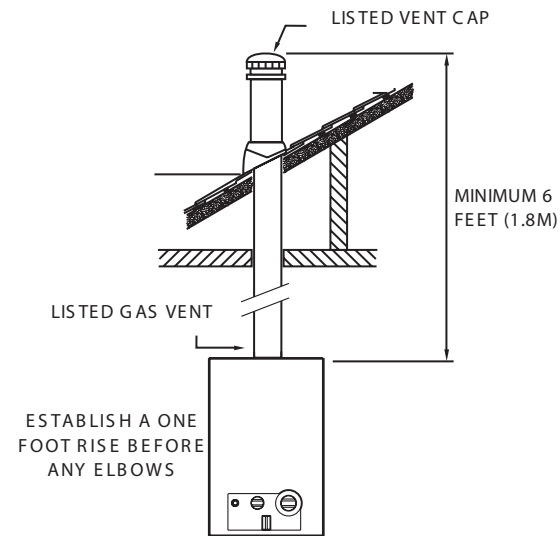
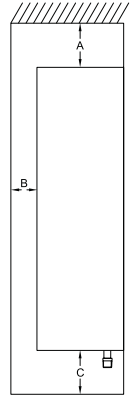

Fig. 2 Venting configuration

### Installation guidelines:

#### Venting:

- ▶ 5" minimum diameter – do not reduce vent size
- ▶ Refer to installation manual for vent material options
- ▶ Do not combination vent with any power vented appliances
- ▶ **Establish a one-foot rise before any elbows**
- ▶ Minimum vent height - 6 feet
- ▶ Horizontal sections must slope upwards at least ¼" for every foot of the horizontal length and be properly supported

#### Gas piping:

- ▶ Heater will not function properly without adequate supply gas pressure
- ▶ Any appliance connector should be ¾" minimum diameter

#### Plumbing:

- ▶ Install the included pressure relief valve and pipe to suitable drain
- ▶ Minimum piping diameter is ¾"
- ▶ Do not solder directly to connections on the bottom of the unit
- ▶ Use full port ball valves for isolation valves

## 2.9 Bosch GWH 425 PN

### Features:

- ▶ Standing pilot ignition
- ▶ 78% thermal efficiency
- ▶ Endless hot water for one major application at a time
- ▶ Modulating gas valve – constant temperature at varying flow rates
- ▶ Model GWH 425 PN N for natural gas (NG) supply
- ▶ Model GWH 425 PN L for liquid propane (LP) supply
- ▶ 15-year warranty

### GWH 425 PN Technical Specifications

Power input	Natural Gas: 31,000 - 117,000 BTU LP Gas: 31,000 - 117,000 BTU
Minimum flow to activate	0.6 gallons per minute (gpm)
Flow rates	45°F rise @ 4.2 gpm 55°F rise @ 3.4 gpm 65°F rise @ 2.9 gpm 77°F rise @ 2.4 gpm 90°F rise @ 2.1 gpm
Thermal Efficiency	NG: 78% LP: 78%
Dimensions	25.75" h x 16.75" w x 8.5" d
Weight	33 lbs.
Modulating gas valve	yes
Ignition	Standing pilot
Accessories	Horizontal vent kit (AQ4) - power vent kit for horizontal venting

### GWH 425 PN Installation Specifications

Gas connection	¾" Male NPT
Water connections	¾" Male NPT
NG gas pressure	Minimum: 7" W.C. Maximum: 14" W.C.
LP gas pressure	Minimum: 11" W.C. Maximum: 14" W.C.
Water pressure	Minimum: 30 PSI Maximum: 150 PSI
Electrical supply	120VAC - plugs in
Vertical venting	5" minimum diameter - natural draft
Horizontal venting	AQ4 horizontal vent kit required for horizontal terminations

### GWH 425 PN Installation Clearances

Top (A)	12"
Front (B)	4"
Back	0"
Sides	4"
Floor (C)	12"

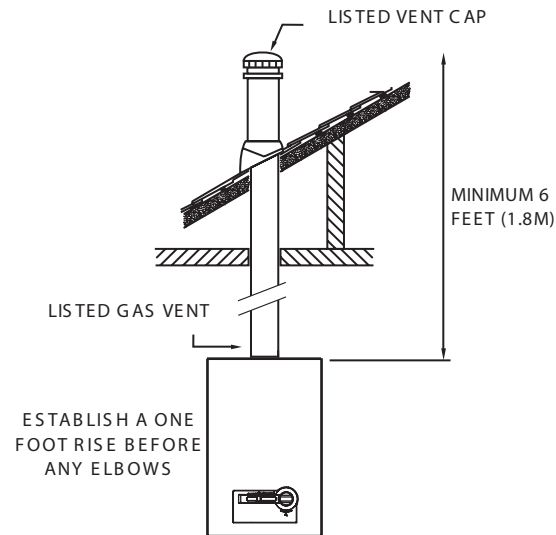
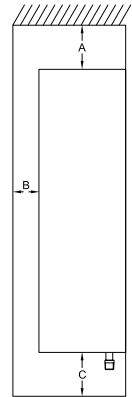

Fig. 4 Venting configuration

### Installation guidelines:

#### Venting:

- ▶ 5" minimum diameter – do not reduce vent size.
- ▶ Refer to installation manual for vent material options
- ▶ Do not combination vent with any power vented appliances.
- ▶ **Establish a one-foot rise before any elbows**
- ▶ Minimum vent height - 6 feet.
- ▶ Horizontal sections must slope upwards at least ¼" for every foot of the horizontal length and be properly supported.

#### Gas piping:

- ▶ Heater will not function properly without adequate supply gas pressure.
- ▶ Any appliance connector should be ¾" minimum diameter

#### Plumbing:

- ▶ Install the included pressure relief valve and pipe to suitable drain.
- ▶ Minimum piping diameter is ¾".
- ▶ Do not solder directly to the bottom of the unit.
- ▶ Use full port ball valves for isolation valves.

## 2.10 Bosch GWH 260 PN

### Features:

- ▶ Standing pilot ignition
- ▶ 78% thermal efficiency
- ▶ Mounts on wall for easy installation
- ▶ Venting: 4" double wall B-vent – natural draft
- ▶ Modulating gas valve – constant temperature at varying flow rates
- ▶ Model GWH 260 PN N for natural gas (NG) supply
- ▶ Model GWH 260 PN L for liquid propane (LP) supply
- ▶ 15-year warranty

### GWH 260 PN Technical Specifications

Gas input	Natural Gas: 30,735 - 74,900 BTU
	LP Gas: 30,735 - 74,900 BTU
Minimum flow to activate	0.6 gallons per minute (gpm)
Flow rates	45°F rise @ 2.6 gpm
	55°F rise @ 2.1 gpm
	65°F rise @ 1.7 gpm
	77°F rise @ 1.5 gpm
	90°F rise @ 1.3 gpm
Thermal Efficiency	NG: 78% LP: 78%
Dimensions	28.8" h x 12.2" w x 8.5" d
Weight	25 lbs.
Modulating gas valve	yes
Ignition	Standing pilot

### GWH 260 PN Installation Specifications

Gas connection	¾" Male NPT
Water connections	¾" Male NPT
NG gas pressure	Minimum: 7" W.C.
	Maximum: 14" W.C.
LP gas pressure	Minimum: 11" W.C.
	Maximum: 14" W.C.
Water pressure (Static)	Minimum: 30 PSI
	Minimum well pressure: 40PSI
	Maximum: 150 PSI
Electrical supply	120VAC - plugs in
Venting	4" double wall B-vent - natural draft

### GWH 260 PN Installation Clearances

Top (A)	12"
Front (B)	4"
Back	0"
Sides	4"
Floor (C)	12"

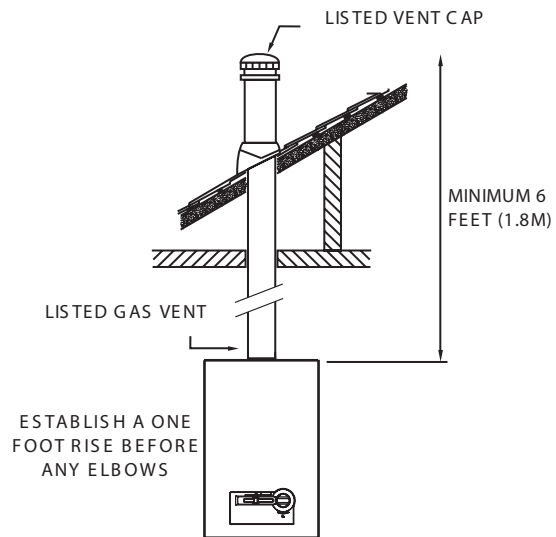

Fig. 4 Venting configuration

### Installation guidelines:

#### Venting:

- ▶ 4" minimum diameter – do not reduce vent size.
- ▶ Refer to installation manual for vent material options
- ▶ Do not combination vent with any power vented appliances.
- ▶ **Establish a one-foot rise before any elbows**
- ▶ Minimum vent height - 6 feet.
- ▶ Horizontal sections must slope upwards at least ¼" for every foot of the horizontal length and be properly supported.

#### Gas piping:

- ▶ Heater will not function properly without adequate supply gas pressure.
- ▶ Any appliance connector should be ¾" minimum diameter

#### Plumbing:

- ▶ Install the included pressure relief valve and pipe to suitable drain.
- ▶ Minimum piping diameter is ¾".
- ▶ Do not solder directly to the bottom of the unit.
- ▶ Use full port ball valves for isolation valves.

## 2.11 Powerstream Pro RP17PT, RP27PT

### Features:

- ▶ Over 90% efficiency rating
- ▶ 10-year warranty on heat exchanger
- ▶ Durable polymer construction
- ▶ External temperature control knob
- ▶ Thermal cut-out for safety
- ▶ Flow sensor to provide a constant output temperature
- ▶ Provides an ENDLESS supply of hot water
- ▶ Weighs less than 25 pounds and fits virtually anywhere
- ▶ No temperature/pressure relief valve necessary (unless required by local codes)

Technical Specifications			
Model	RP17PT	RP27PT	
Efficiency	90%	94%	
Dimensions	15 ½" x 15 ¼" x 4 ½"	15 ½" x 15 ¼" x 4 ½"	
Weight	20 lbs.	22 lbs.	
Water fittings	¾" Male NPT	¾" Male NPT	
Activation rate	0.6 gpm	0.8 gpm	
Electrical requirements			
Volts	240	240	
Kilowatts	17.25kW	26.85kW	
Amps	<i>U.S.A</i> 80 (2x40 amps) <i>Canada</i> 80 (1x80 amps)	120 (3x40 amps) 120 (1x120amps)	
Wire size	<i>U.S.A</i> 8 AWG (4 conductors & ground)	<i>U.S.A</i> 8 AWG (4 conductors & ground)	
	<i>Canada</i> Check Canadian Electrical Code (C22.1-02)	<i>Canada</i> Check Canadian Electrical Code (C22.1-02)	
Phase	Single	Single	
Maximum flow rate at given temperature rise			
45°F Rise	2.6 gpm	4.0 gpm	
50°F Rise	2.3 gpm	3.7 gpm	
60°F Rise	2.0 gpm	3.0 gpm	
70°F Rise	1.7 gpm	2.6 gpm	
80°F Rise	1.5 gpm	2.2 gpm	

### Installation guidelines:

#### Electrical:

- ▶ Minimum electrical service for RP17PT is 150 amps.
- ▶ Minimum electrical service for RP27PT is 200 amps.
- ▶ Minimum wire size for both models is 8 AWG.

#### Plumbing:

- ▶ Do not solder directly to connections on the bottom of the unit.
- ▶ Use unions to facilitate easy future maintenance.
- ▶ Use full port ball valves for isolation valves.

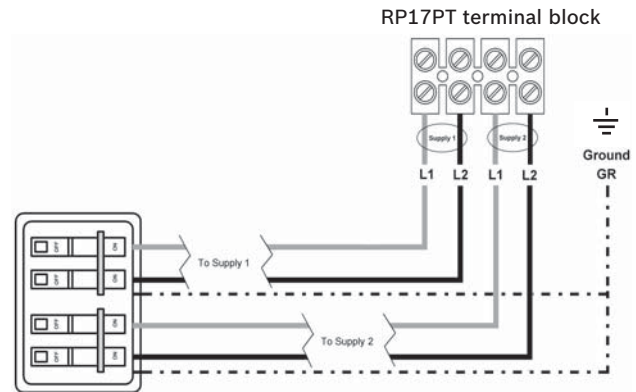

2 independent  
40 amp double-pole  
circuit breakers

Fig. 5 RP17PT Electrical Connections

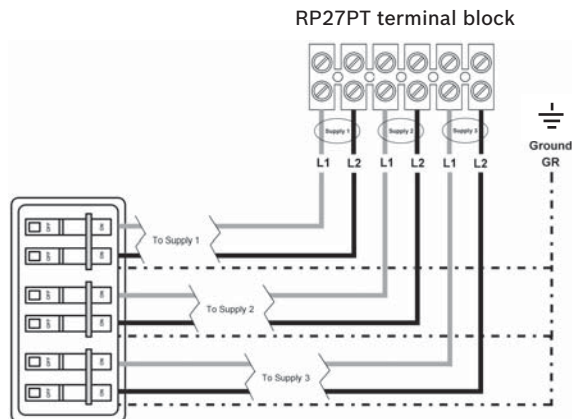

3 independent  
40 amp double-pole  
circuit breakers

Fig. 6 RP27PT Electrical Connections

## 2.12 Powerstream Pro RP1P, RP2P, RP3P, RP7P, RP9P,RP12PT

### Features:

- ▶ 5-year warranty on heat exchanger
- ▶ Saves space
- ▶ Installs vertically or horizontally (Model RP12PT only installs horizontally)
- ▶ All models must be hardwired
- ▶ Solid copper heat exchanger, copper sheathed elements and tough plastic housing
- ▶ High/low kW settings possible within most models
- ▶ Model RP12PT has thermostatic adjustable control

### Installation guidelines:

#### Electrical:

- ▶ Refer to the chart below as specification varies by model

#### Plumbing:

- ▶ Do not solder directly to connections on the bottom of the unit.
- ▶ Use unions to facilitate easy future maintenance.
- ▶ Use full port ball valves for isolation valves.

Technical Specifications											
Model Part #	Wire Size	Voltage	Amps	High kW	Low kW	Degree rise at flow rates (GPM)*					Activation rate (GPM)
						0.5	0.75	1.0	1.5	2.0	
RP1P	8AWG	240	40	9.50	—	—	84°	64°	42°	32°	0.75
			20	—	4.75	—	42°	32°	21°	16°	
RP2P	10AWG	277	22	6.00	—	81°	55°	42°	27°	—	0.50
			11	—	3.00	41°	28°	21°	14°	—	
RP3P	10AWG	120	29	3.40	—	41°	28°	20°	—	—	0.50
RP7P	10AWG	240	30	7.20	—	—	63°	48°	32°	24°	0.75
			15	—	3.60	—	32°	24°	16°	12°	
RP9P	8AWG	277	35	9.50	—	—	84°	64°	42°	32°	0.75
			18	—	4.75	—	42°	32°	21°	16°	
RP12PT	6AWG	240	50	12.00	—	—	90°	72°	52°	42°	0.75



### 2.13 Ariston Pro GL2.5Ti, GL4Ti, GL8Ti

#### Features:

- ▶ Point of use mini tank
- ▶ 3 models
- ▶ Adjustable thermostat with thermal cut-out
- ▶ Dielectric isolation on inlet/outlet connections
- ▶ Units can be wall hung (bracket included) or floor mounted
- ▶ Durable poly-composite housing will not dent and resists corrosion
- ▶ Temperature/pressure relief valve included (plumb correctly for discharge)
- ▶ Simple 120V AC plug-in connection
- ▶ 8-year warranty

#### Installation guidelines:

##### Electrical:

- ▶ Follow local codes for electrical outlets for water heaters
- ▶ All models plugin to standard wall outlet.

##### Plumbing:

- ▶ Use full port valves for isolation valves.
- ▶ Do not solder directly to the plumbing connections.

Technical Specifications			
	GL2.5Ti	GL4Ti	GL8Ti
Tank Volume	2.75 gallons	3.85 gallons	7.0 gallons
Nominal Dimensions	14" x 14" x 11"	14" x 14" x 14"	17 ½" x 17 ½" x 14 ½"
Voltage	120V	120V	120V
Amperage	12.5 amps	12.5 amps	12.5 amps
Wire Type	Plug-in	Plug-in	Plug-in
Heating Capacity	1500 watts	1500 watts	1500 watts
Recovery at 90° rise	7 gph	7 gph	7gph
Temperature range	65-145°F	65-145°F	65-145°F
Water connections	½" NPT	½" NPT	¾" NPT
Maximum water pressure	150 PSI	150 PSI	150 PSI
Relief valve	Installed	Installed	Included

## **3 Domestic Water Heating Applications**

### **Potable water**

Potable water is water that is suitable for drinking. Bosch Water Heating appliances are approved to heat potable water only. Heating any other liquid other than potable water will void the manufacturer's warranty covering the appliance.

### **Introduction**

This chapter covers the various application techniques Bosch Water Heating recommends. The schematics are to be used by professional contractors in designing a domestic water heating system. The applications covered range from single sink point-of-use applications to multi-appliance central domestic recirculation applications.

### **3.1 Point-of-use applications**

Point-of-use applications cover the small applications that a large water heater would be inefficient for. Installing a smaller heater at a point-of-use puts the heater near the hot water demand and reduces the wait for hot water. Common applications for these appliances include homes, offices, warehouses, service stations, stores, concession stands, and summer camps.

### 3.1.1 Ariston mini tank

Simply tap into the cold water line and install the water heater directly at the sink. All models plug into a standard 120 volt outlet. Heater can be wall mounted, or sit on the floor.

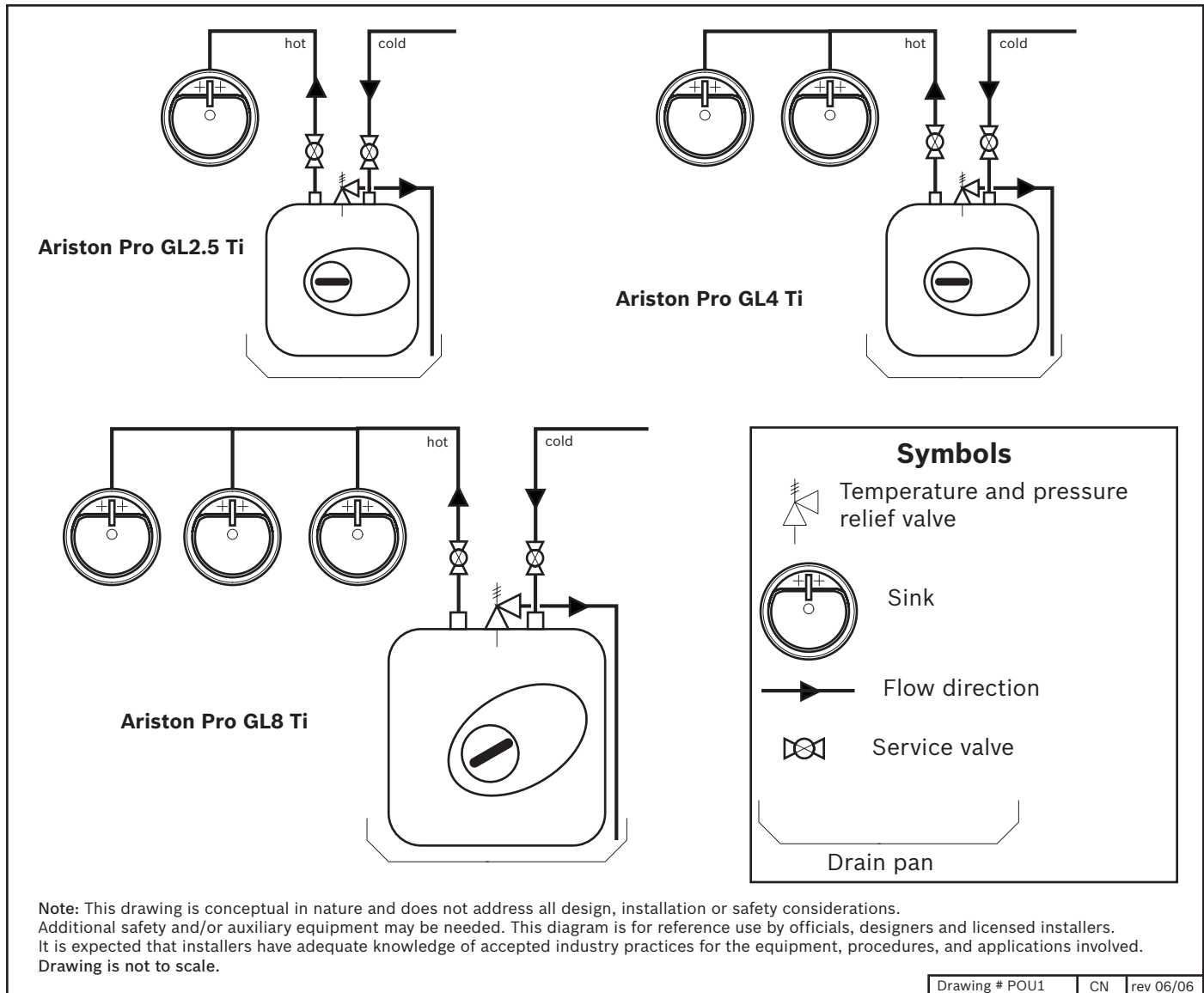

### 3.1.2 Powerstream Pro electric point-of-use tankless water heater

PowerstreamPro point-of-use water heaters come in four models to serve a wide range of applications. Finding the right model depends upon your desired temperature and flow rate. Use the table below to find the model best suited to your customer's needs. Flow controls and faucet aerators can greatly enhance performance.

Note: Water heater must be filled with water and purged of air prior to supplying power.

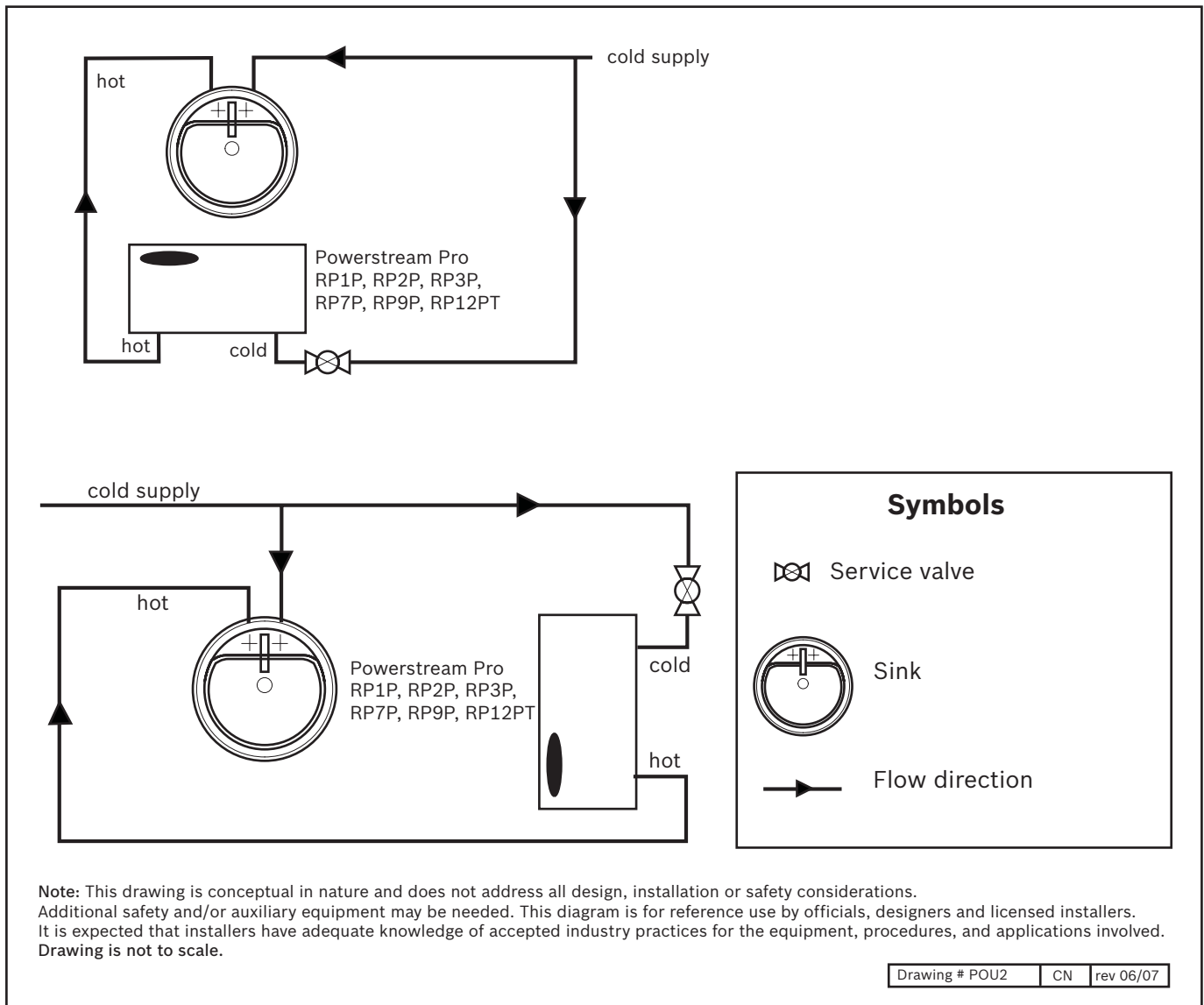

### 3.1.3 Bosch GWH-260PN gas tankless water heater

The Bosch GWH-260PN gas tankless water heater offers a compact and lightweight design for easy installation. This unit is equipped with standing pilot ignition and is intended for low volume applications.

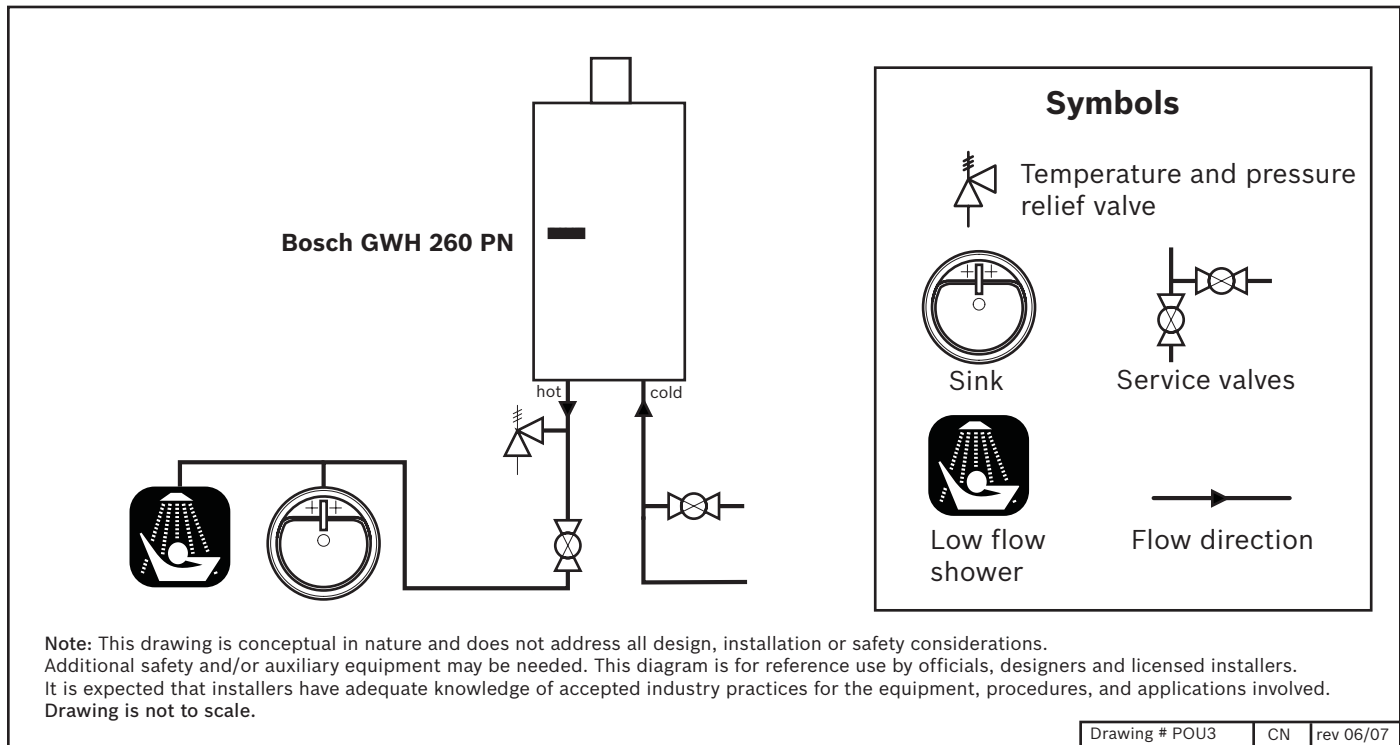

### 3.2 Whole house applications

Whole house applications cover the typical home applications up to a 2 or 3 bedroom house. See the sizing guide (Section 2.1) to determine the best Bosch water heater model for your application. An enhanced design including an Ariston mini tank in line to the hot water source will reduce the wait time for hot water and improve temperature stability.

#### 3.2.1 Powerstream Pro whole house applications

The RP17PT and RP27PT must be hard wired directly to the breaker box.

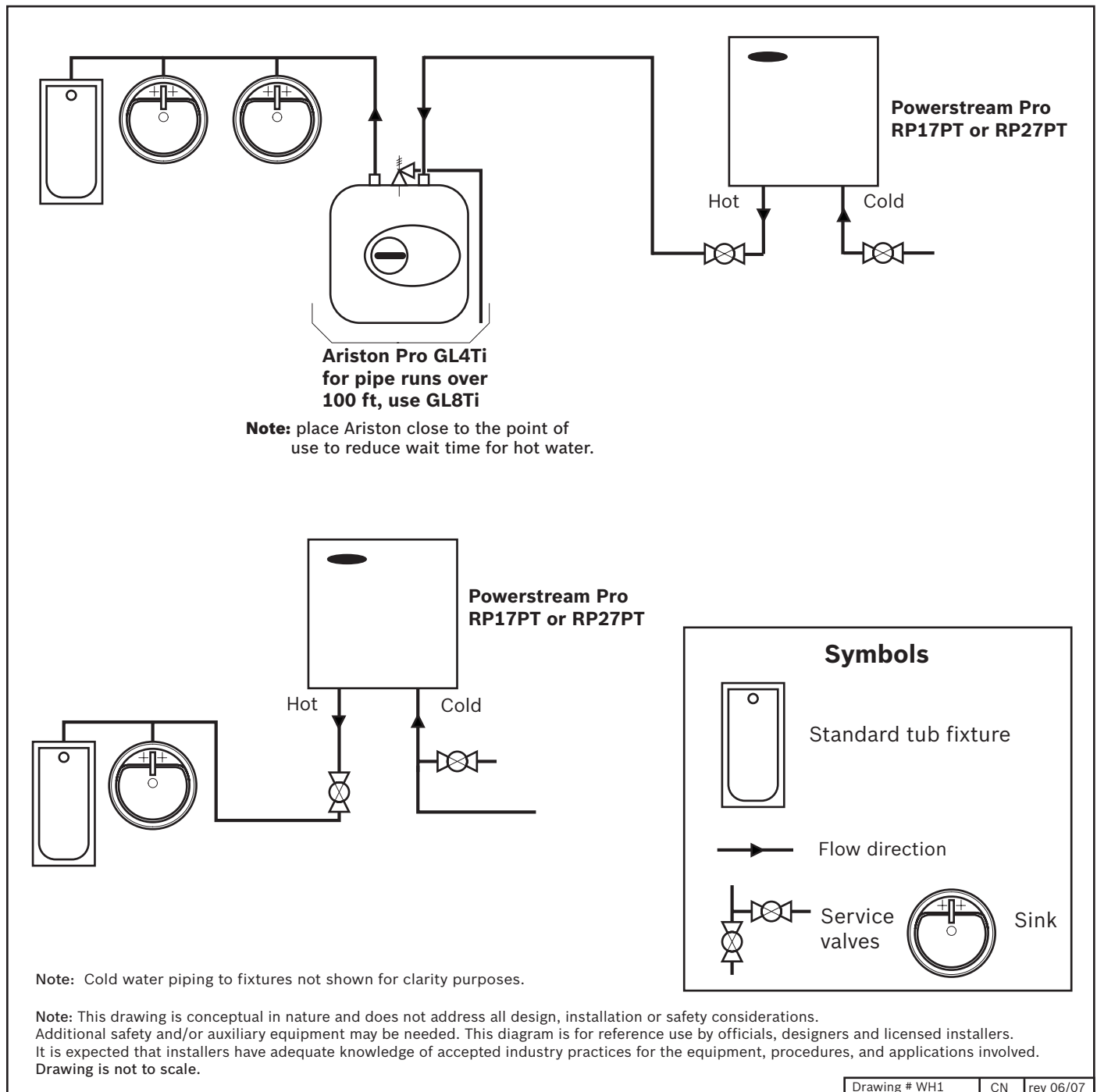





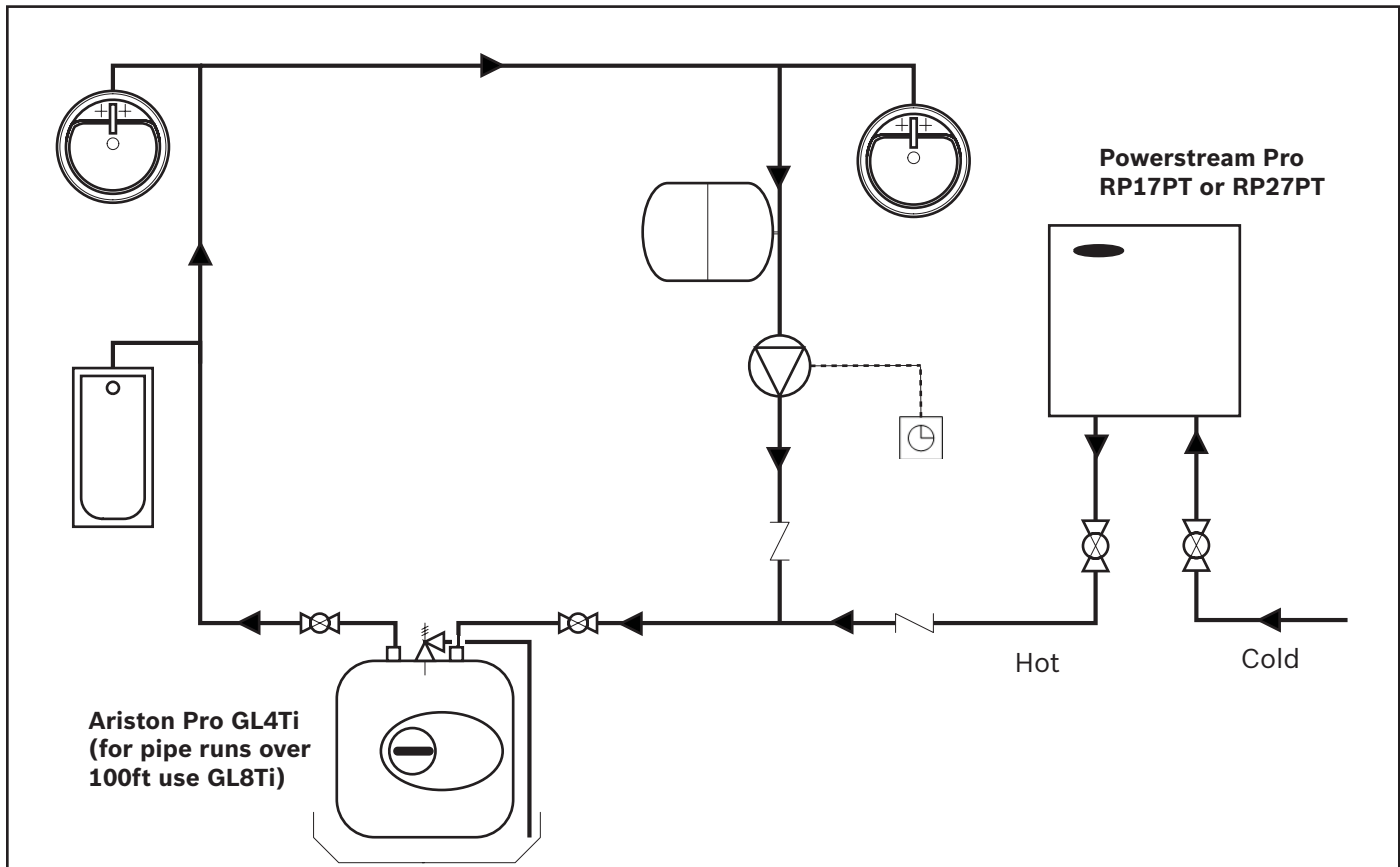

**3.2.2 Powerstream Pro whole house application with domestic recirculation loop**

The circulator should be controlled by an external aquastat, or with a timer to run only during times of expected hot water usage.

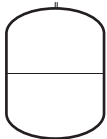
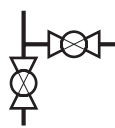

**Symbols**

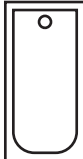
	Bronze circulator pump sized according to UPC standards (Taco Bronze 007 or Grundfos 15-42B will cover most homes up to 3 bathrooms)		Flow check valve		Timer or Aquastat		Flow direction
	Potable water expansion tank		Service valves		Sink		Standard tub fixture

Note: Cold water piping to fixtures not shown for clarity purposes.

Note: This drawing is conceptual in nature and does not address all design, installation or safety considerations. Additional safety and/or auxiliary equipment may be needed. This diagram is for reference use by officials, designers and licensed installers. It is expected that installers have adequate knowledge of accepted industry practices for the equipment, procedures, and applications involved. Drawing is not to scale.

Drawing # WH1R | CN | rev 06/07

**3.2.3 Bosch ProTankless gas water heater**

Below are two examples of Bosch ProTankless gas water heater installations for the whole house. One example shows an Ariston mini tank in line for reduced hot water wait time and increased temperature stability.

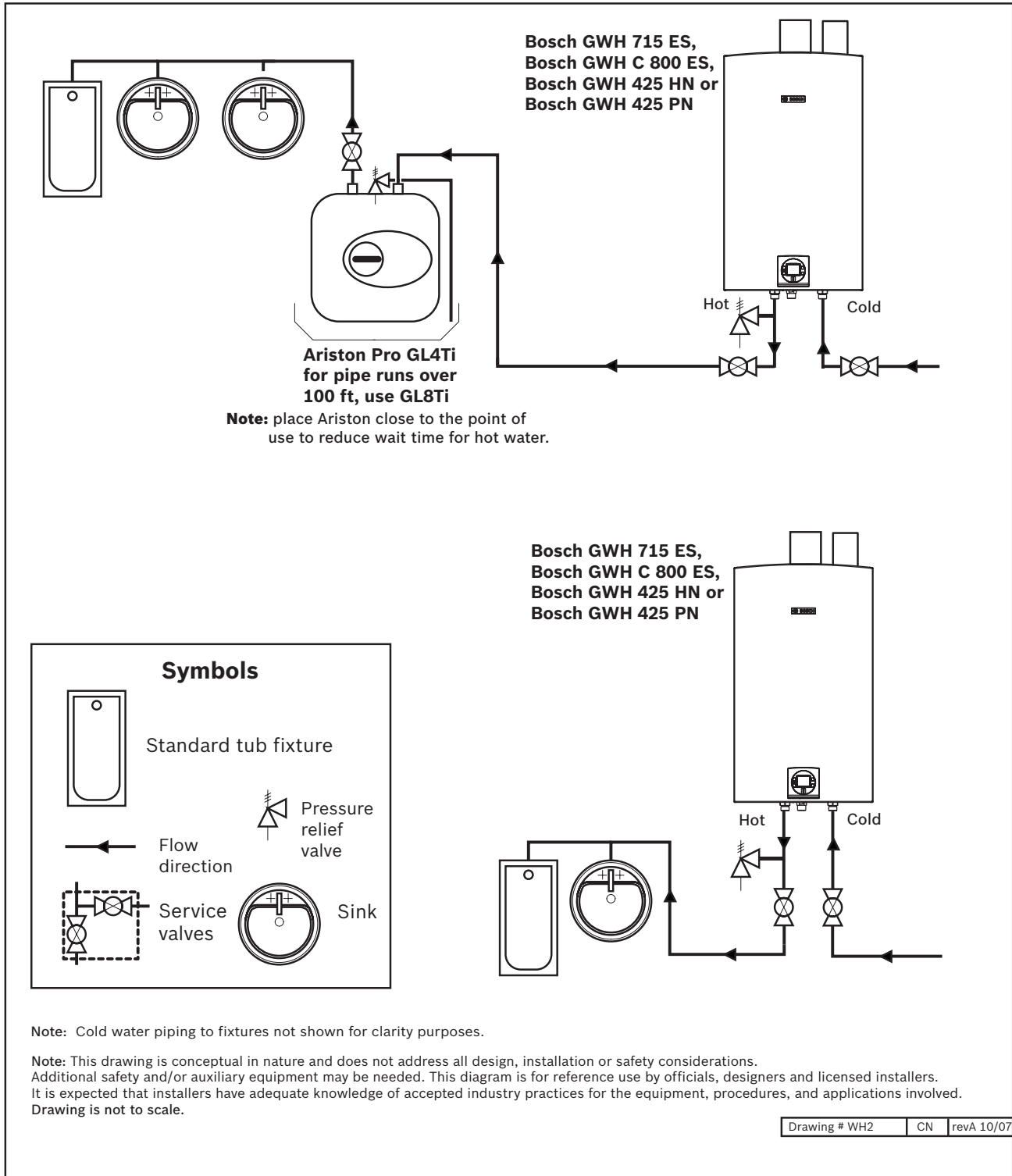



**3.2.4 Bosch ProTankless gas water heater with domestic recirculation loop**

The circulator should be controlled by an external aquastat, or with a timer to run only during times of expected hot water usage.

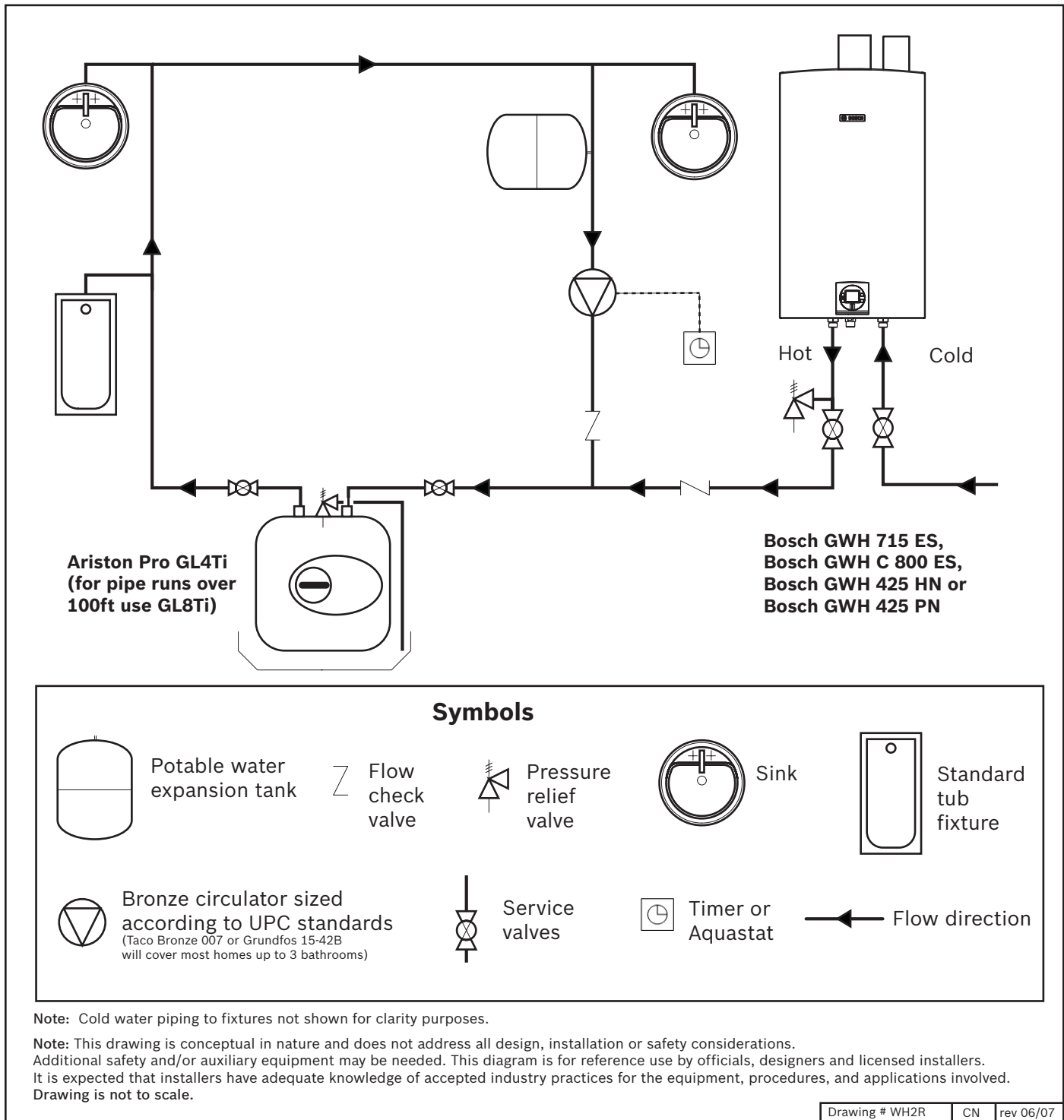

## **4 High Volume Potable Water Heating**

### **Potable water**

Potable water is water that is suitable for drinking. Bosch Water Heating appliances are approved to heat potable water only. Heating any other liquid other than potable water will void the manufacturer's warranty covering the appliance.

### **Introduction**

This section lays out the options for high volume water heating for large residential and light commercial applications including continuous flows and high volume demands of large home and commercial applications.

### **4.1 Parallel unit applications**

Parallel unit applications have twice the activation rate of single unit applications. The following designs are for continuous flow, high volume hot water needs. Not intended for residential use. To balance flows use reverse return piping. (shown below)

#### 4.1.1 Bosch ProTankless gas water heater in parallel for commercial applications

Two Bosch ProTankless units will have double the activation rate of a single unit. When sizing gas line, ensure the gas line is sized to carry the BTU load of two units plus any additional gas appliances. See the installation manuals for a gas line sizing chart.

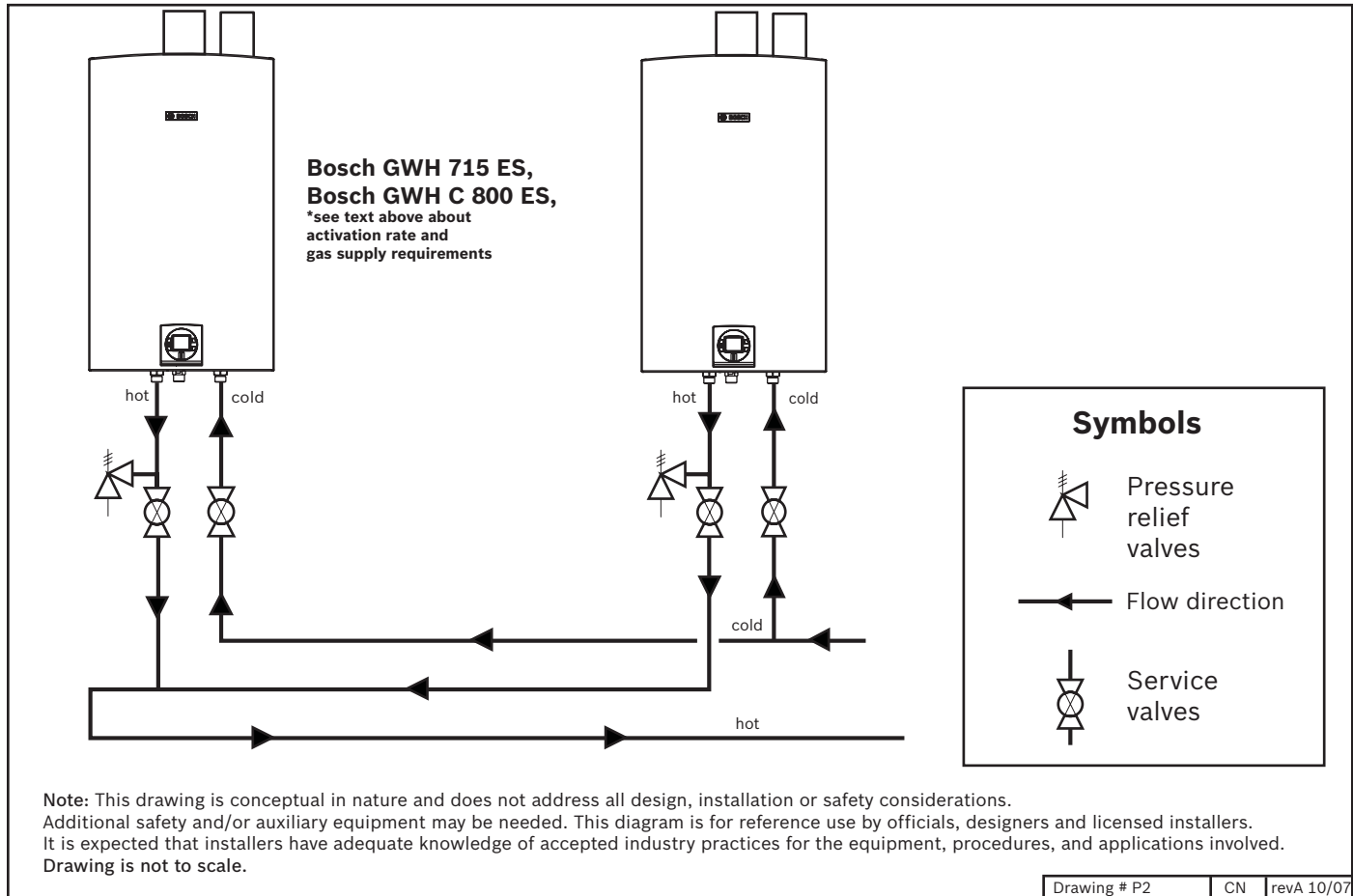

## 4.2 Cascading unit applications

A cascading application should be considered if the potential hot water demand exceeds the capacity of one GWH 715 ES or GWH C 800 ES. The cascading set up supports variable flow inputs and is designed for large homes and commercial applications.

### 4.2.1 GWH 715 ES and GWH C 800 ES cascading

Cascading allows up to two appliances to be connected in parallel. One of the appliances will serve as the controlling Master appliance and will attempt to meet the hot water demand. If the hot water demand is beyond the capacity of the Master appliance, a signal is sent to the Slave appliance to begin operation.

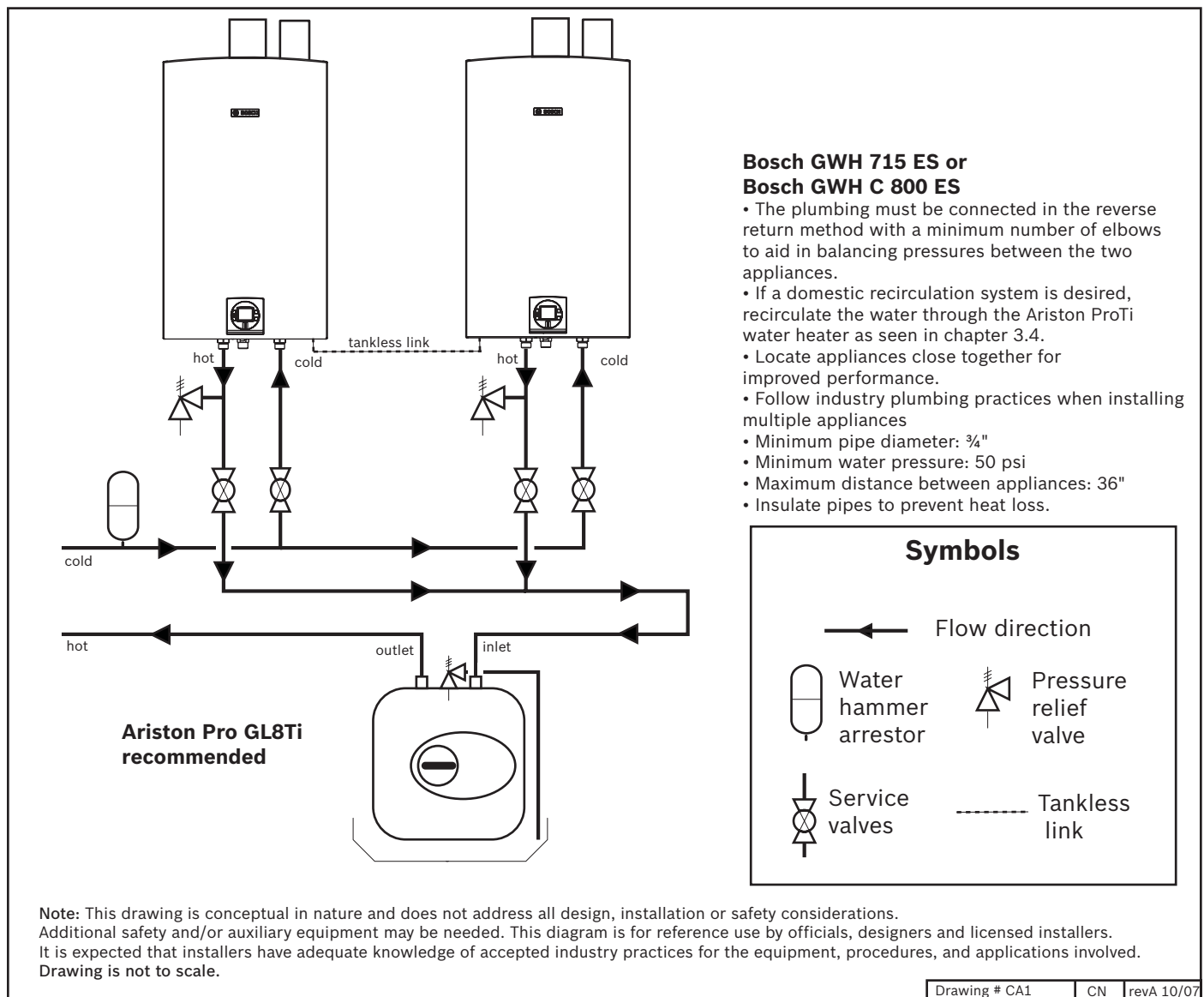

### 4.3 External storage tank loading applications.

#### Introduction

This section lays out tank loading options for high volume water heating for large residential and light commercial applications including continuous flows and high volume demands of large home and commercial applications.

#### 4.3.1 GWH 345/450 ESR pressure drops and circulator guidelines

- ▶ The maximum amp draw for any circulator connected directly to the appliance must not exceed 1.5 amps
- ▶ Circulator should be sized by the professional plumbing contractor
- ▶ Bronze or stainless steel circulators required for all open loop applications

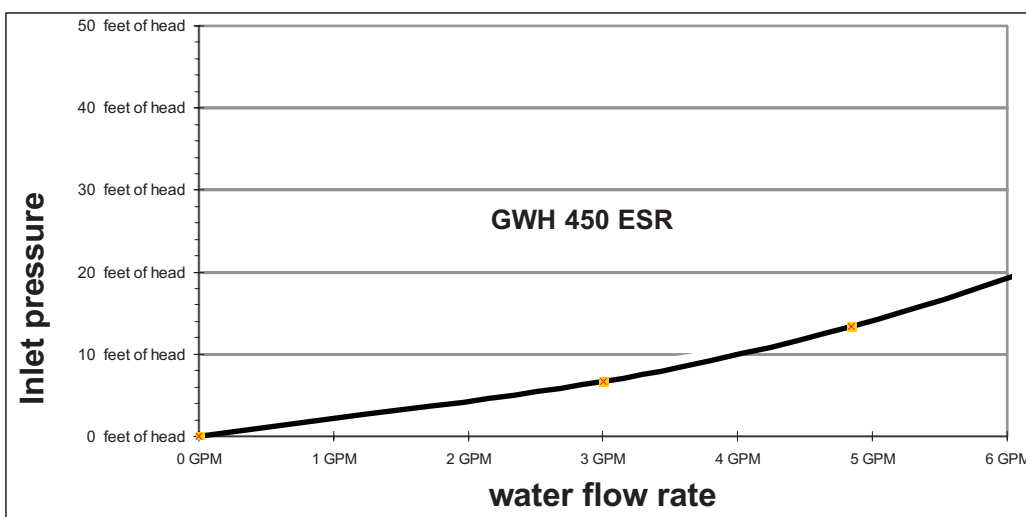
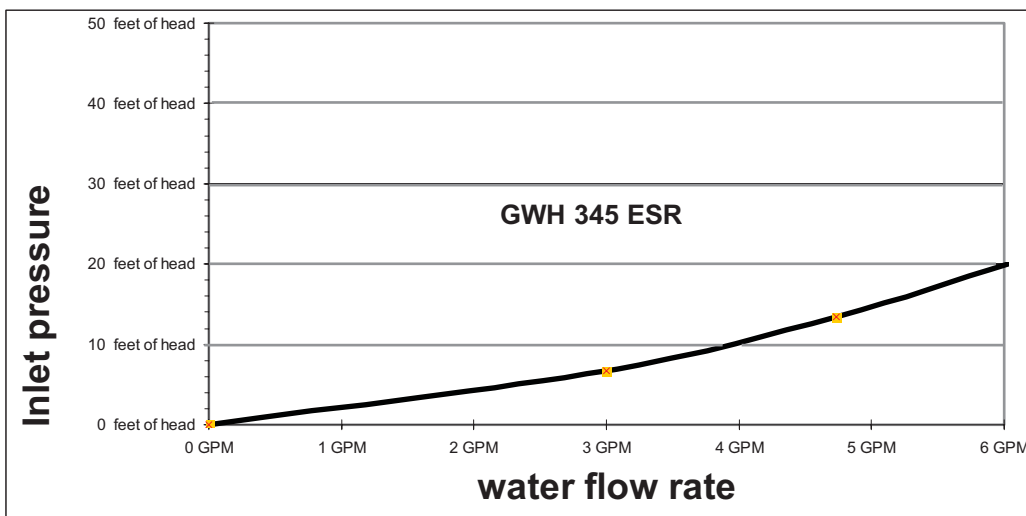

Pressure drop curves

Note : Flow above 6 GPM is not permitted.

**4.3.2 Single unit tank loading application plumbing diagram**

The GWH 345/450 ESR is specifically designed for this application.

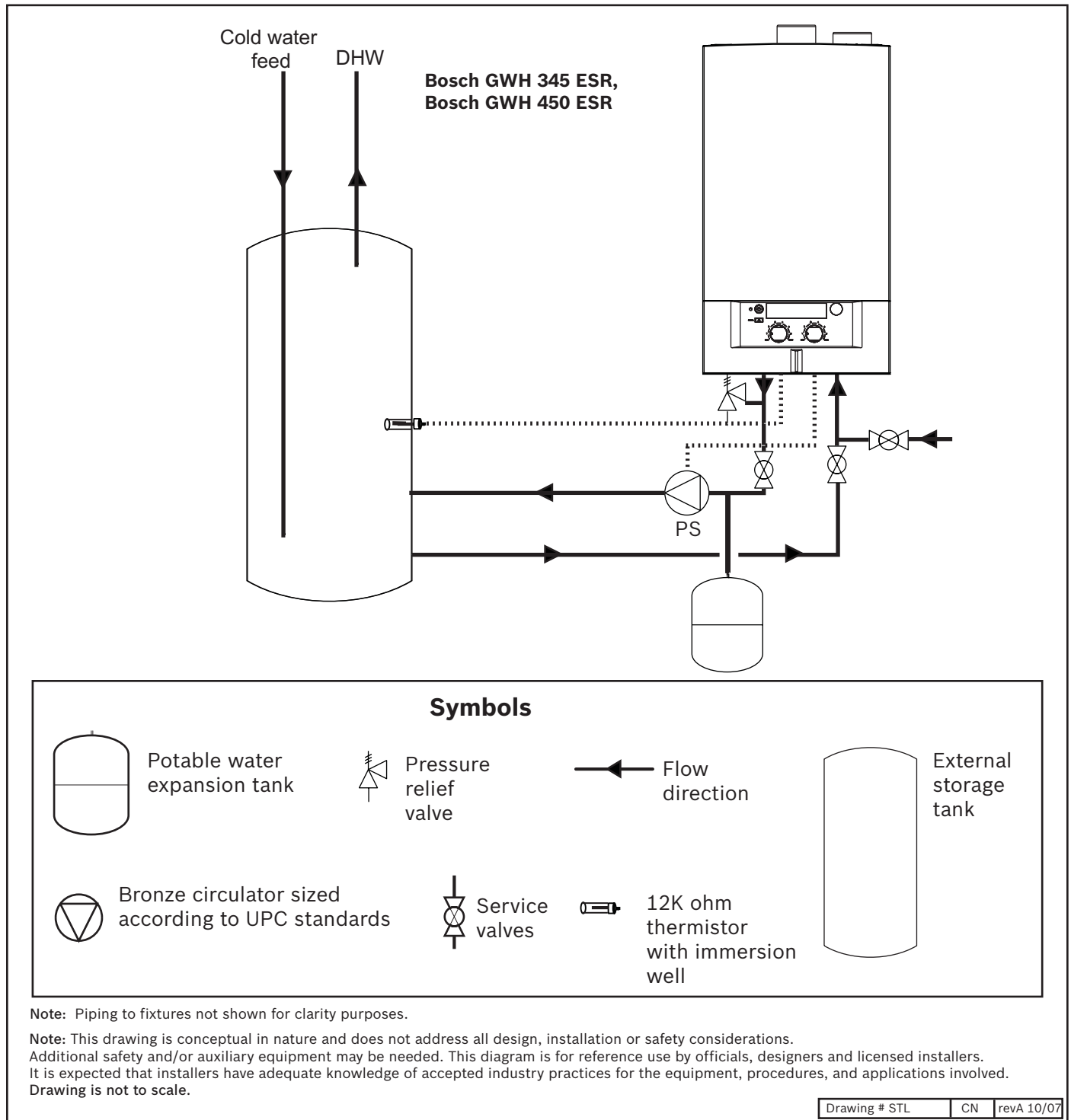

**4.3.2 Single unit tank loading application electrical diagram**

The following shows the appropriate electrical connections for plumbing diagram 4.3.2

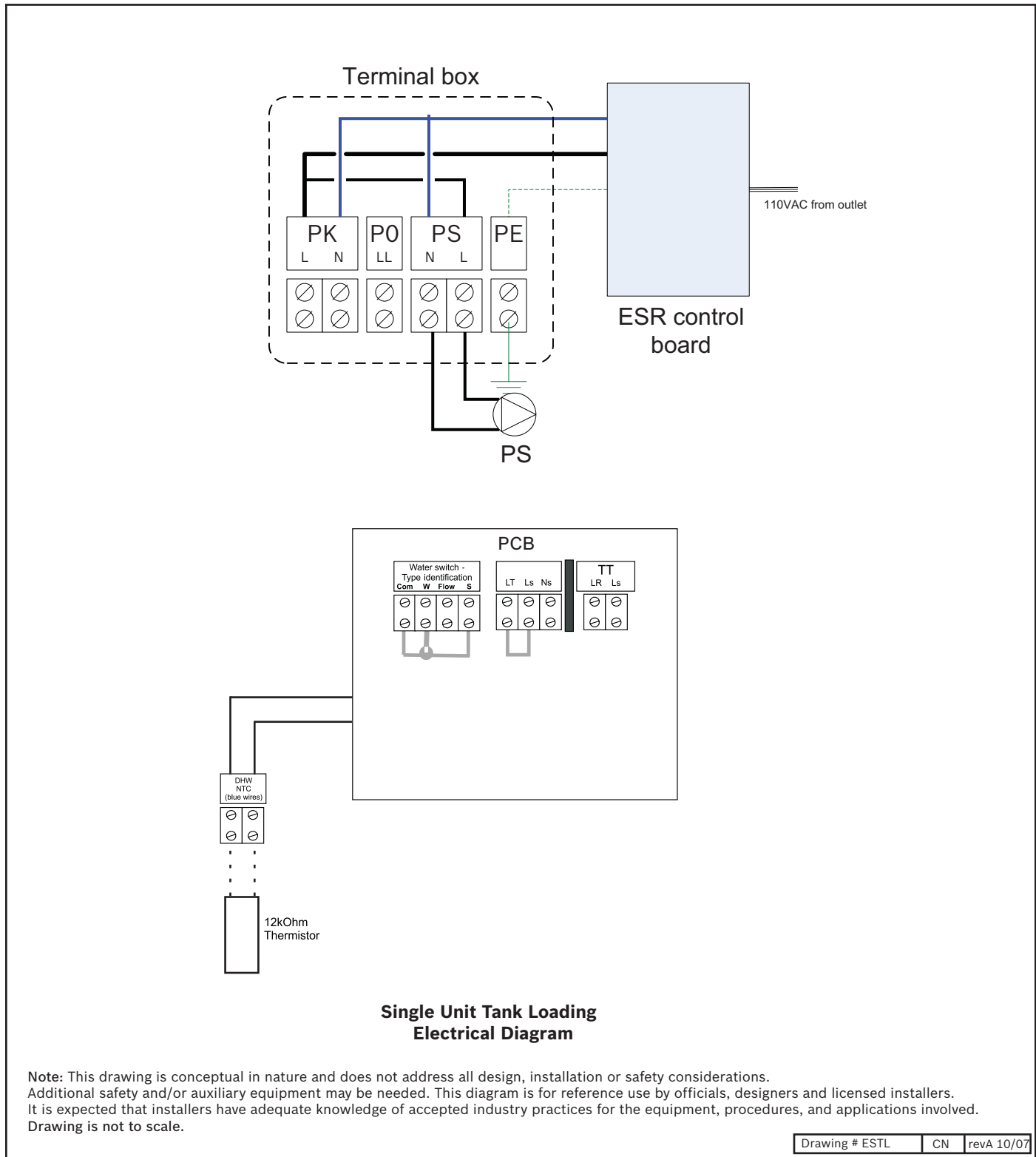

## 5 Open Loop Space Heating

### Introduction

This section is designed to provide a road map of techniques for using a tankless water heater to heat domestic water and at the same time provide space heating in residential applications. As with all installations, check with the local authority having jurisdiction. Some jurisdictions may not allow these types of applications.

### 5.1 External storage tank

The appliances shown in this section are approved under ANSI Z21.10.3 and CSA 4.3 as circulating gas water heaters. Only open loop applications are approved under this standard.

#### 5.1.1 Radiant space heating and DHW plumbing diagram

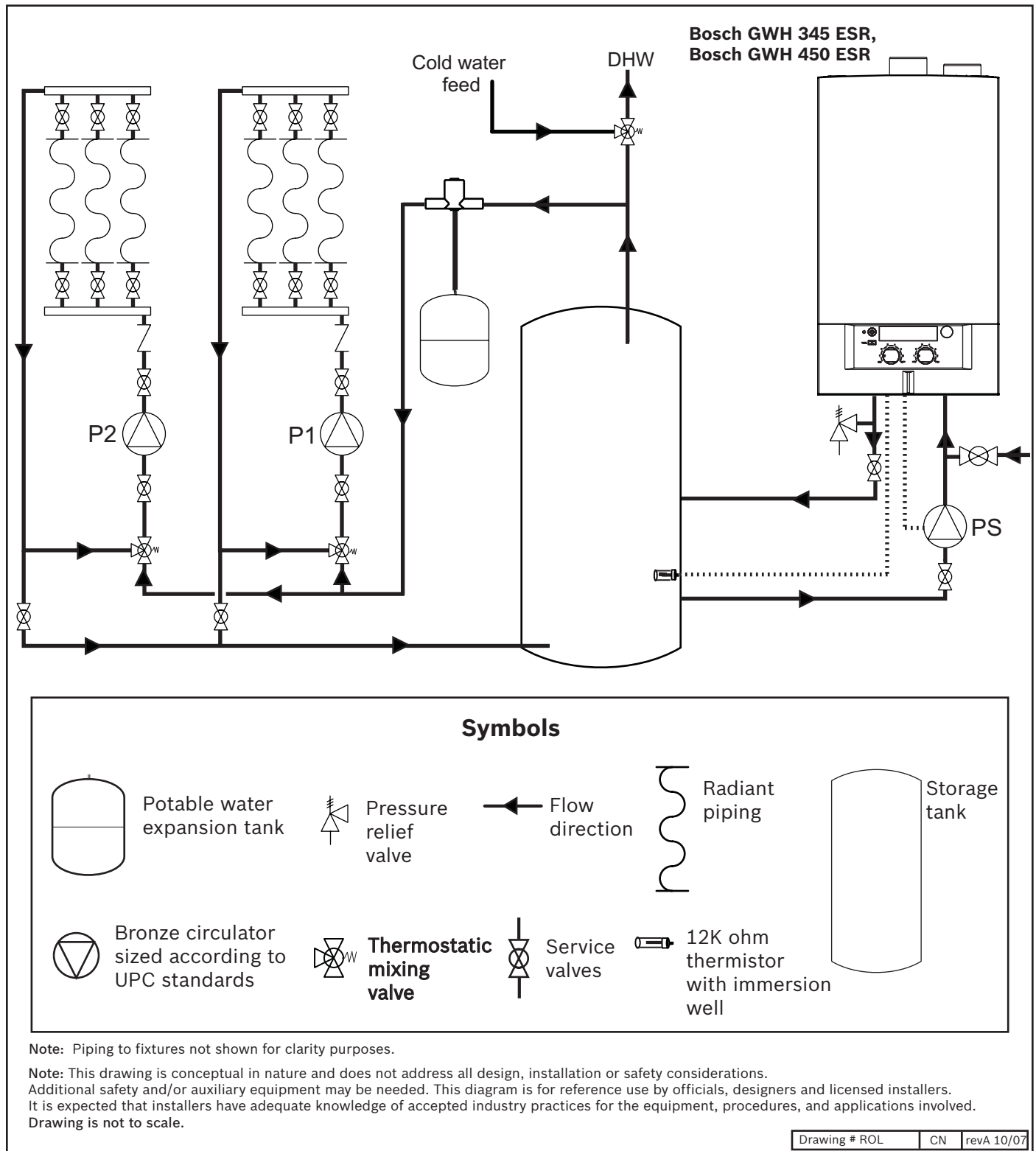



5.1.1 Radiant space heating and DHW electrical diagram

The following shows the appropriate electrical connections for plumbing diagram 5.1.1

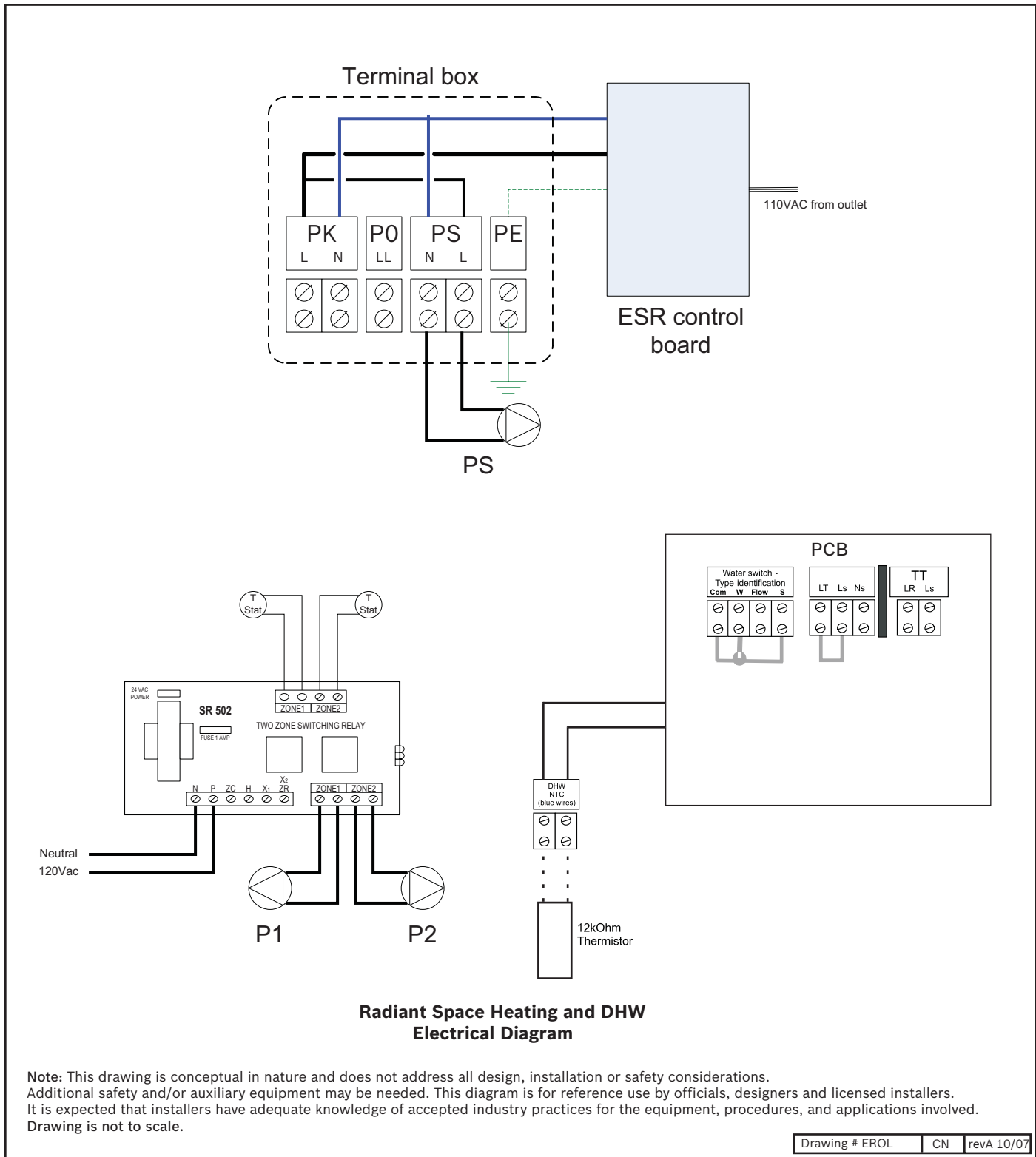

5.1.2 Fan coil space heating and DHW plumbing diagram

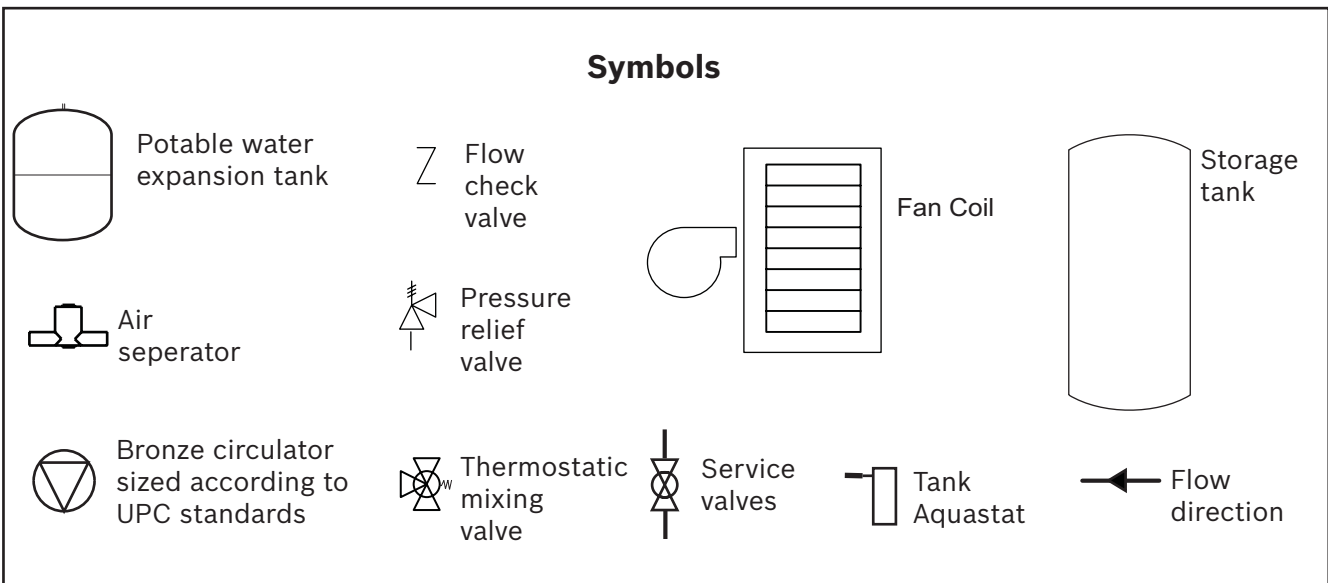
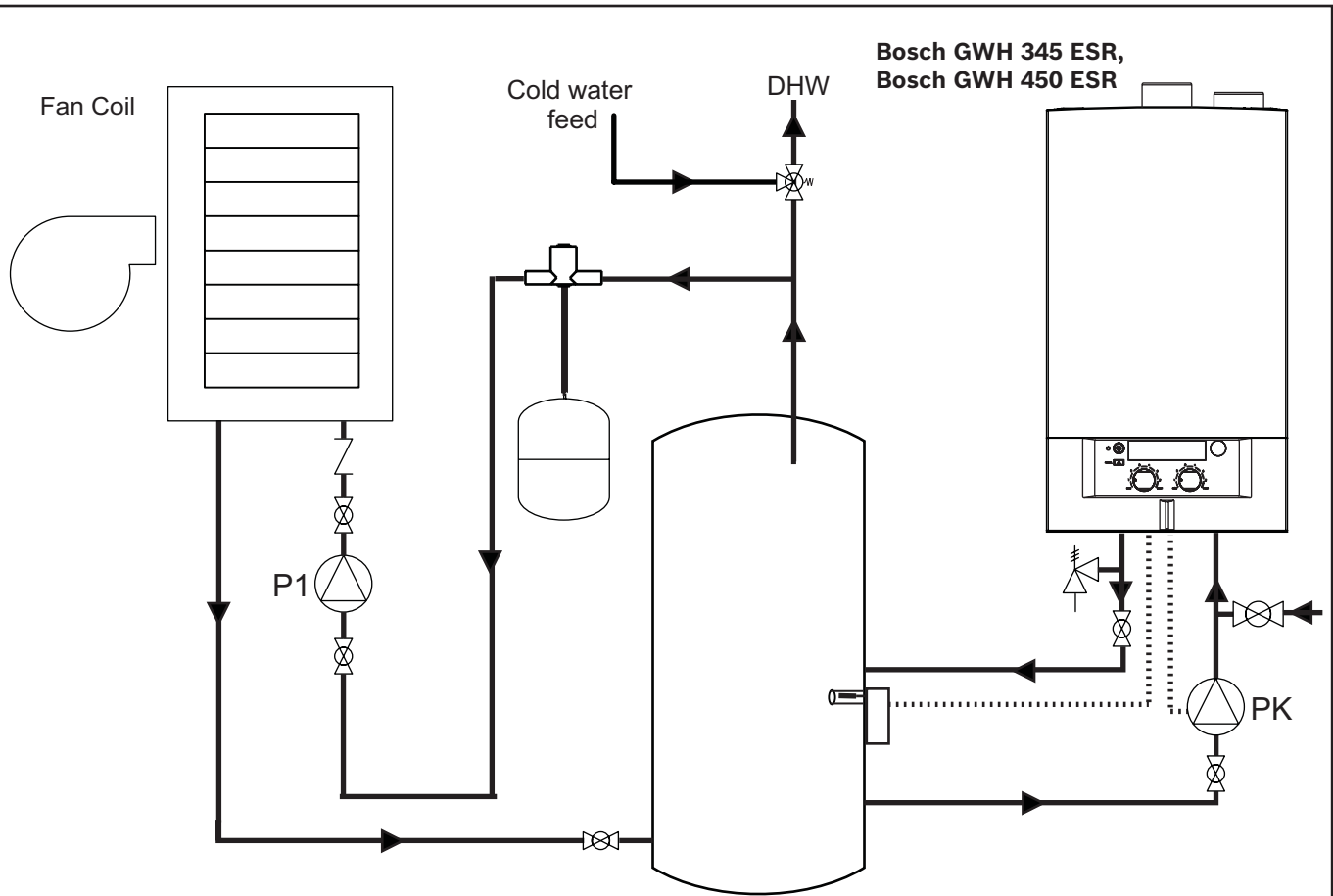

Note: Piping to fixtures not shown for clarity purposes.

Note: This drawing is conceptual in nature and does not address all design, installation or safety considerations. Additional safety and/or auxiliary equipment may be needed. This diagram is for reference use by officials, designers and licensed installers. It is expected that installers have adequate knowledge of accepted industry practices for the equipment, procedures, and applications involved. Drawing is not to scale.

Drawing # FCOL    CN    revA 10/07

5.1.2 Fan Coil space heating and DHW electrical diagram

The following shows the appropriate electrical connections for plumbing diagram 5.1.2

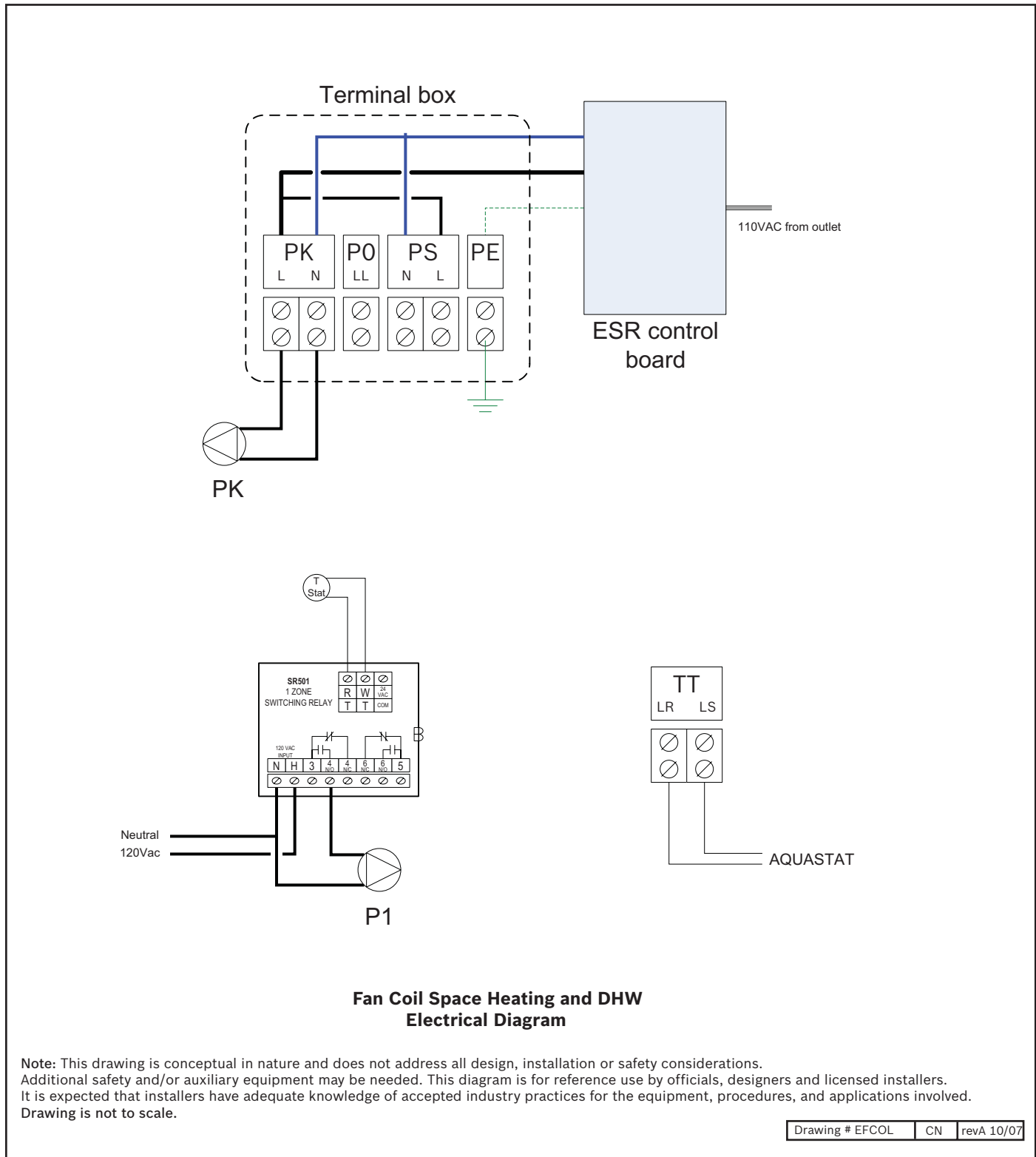

5.1.3 Baseboard/ Radiant Panel space heating and DHW plumbing diagram

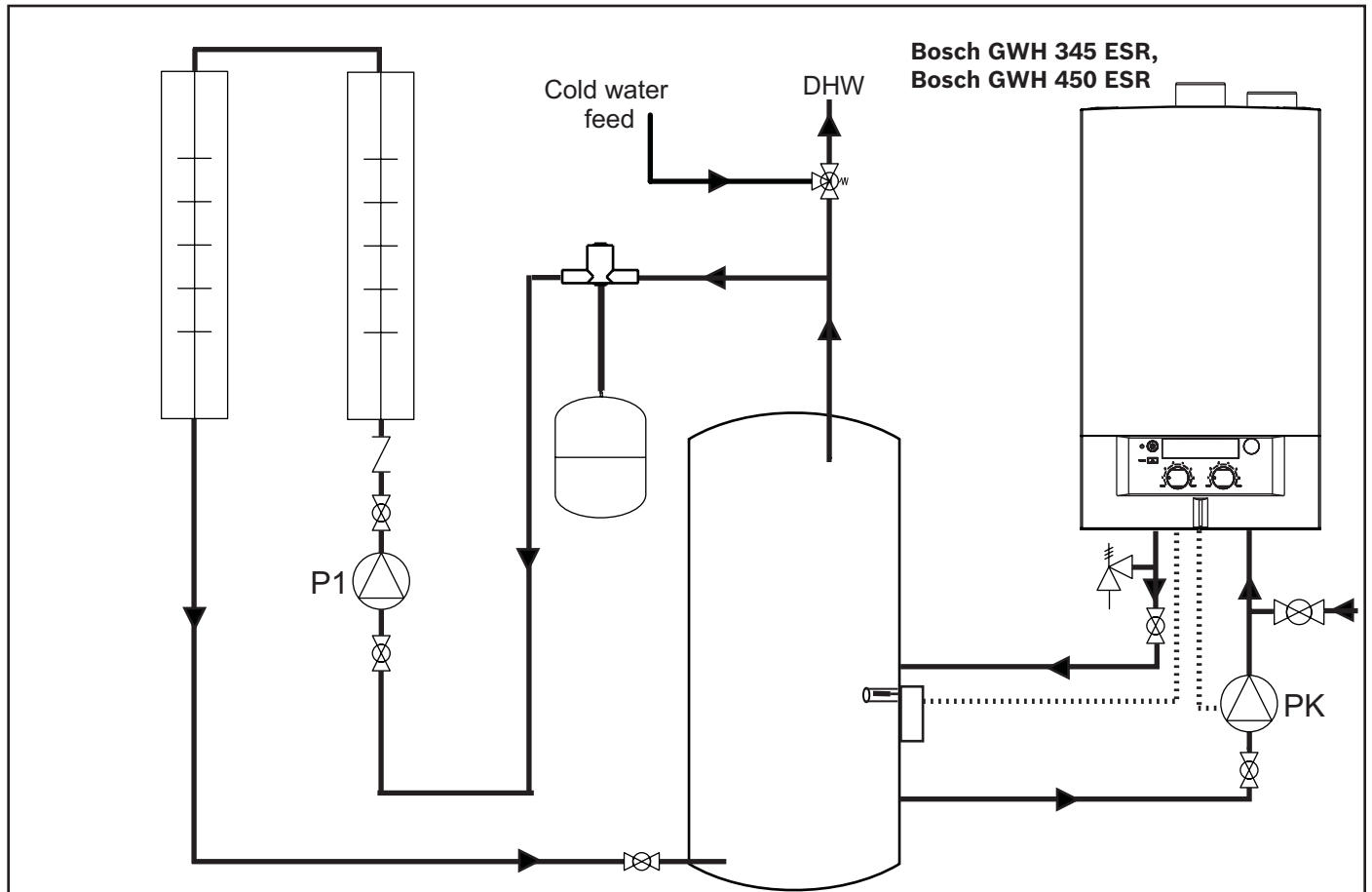

**Symbols**

	Potable water expansion tank		Flow check valve		Flow direction		Baseboard/Radiant Panel		Storage tank
	Air separator		Pressure relief valve		Tank Aquastat				
	Bronze circulator sized according to UPC standards		Thermostatic Mixing valve		Service valves				

Note: Piping to fixtures not shown for clarity purposes.

Note: This drawing is conceptual in nature and does not address all design, installation or safety considerations. Additional safety and/or auxiliary equipment may be needed. This diagram is for reference use by officials, designers and licensed installers. It is expected that installers have adequate knowledge of accepted industry practices for the equipment, procedures, and applications involved. Drawing is not to scale.

Drawing # BB OL CN revA 10/07

**5.1.3 Baseboard/Radiant Panel space heating and DHW electrical diagram**

The following shows the appropriate electrical connections for plumbing diagram 5.1.3

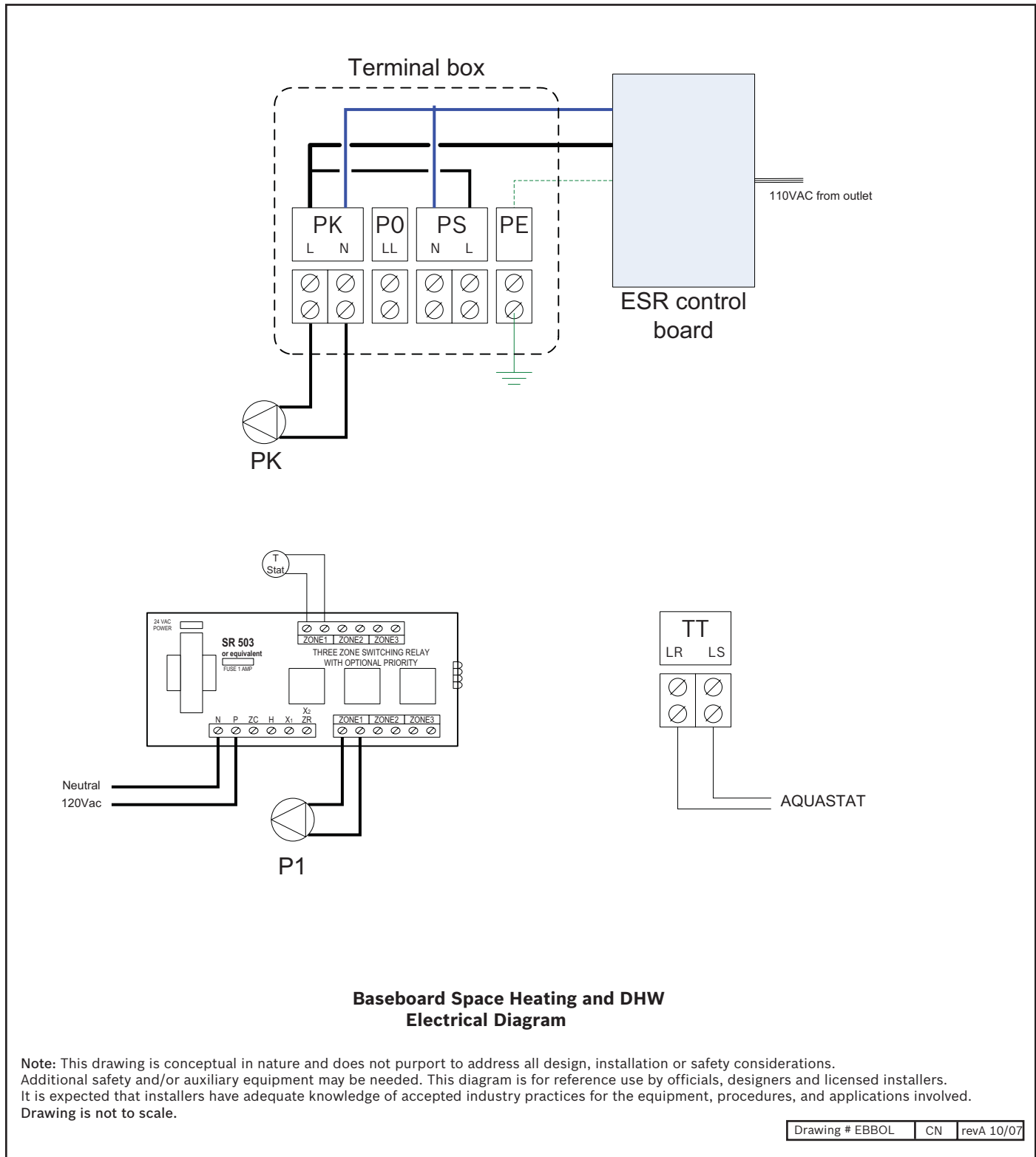

5.1.4 Baseboard/ Radiant Panel space heating and DHW (with Ariston mini tank) plumbing diagram

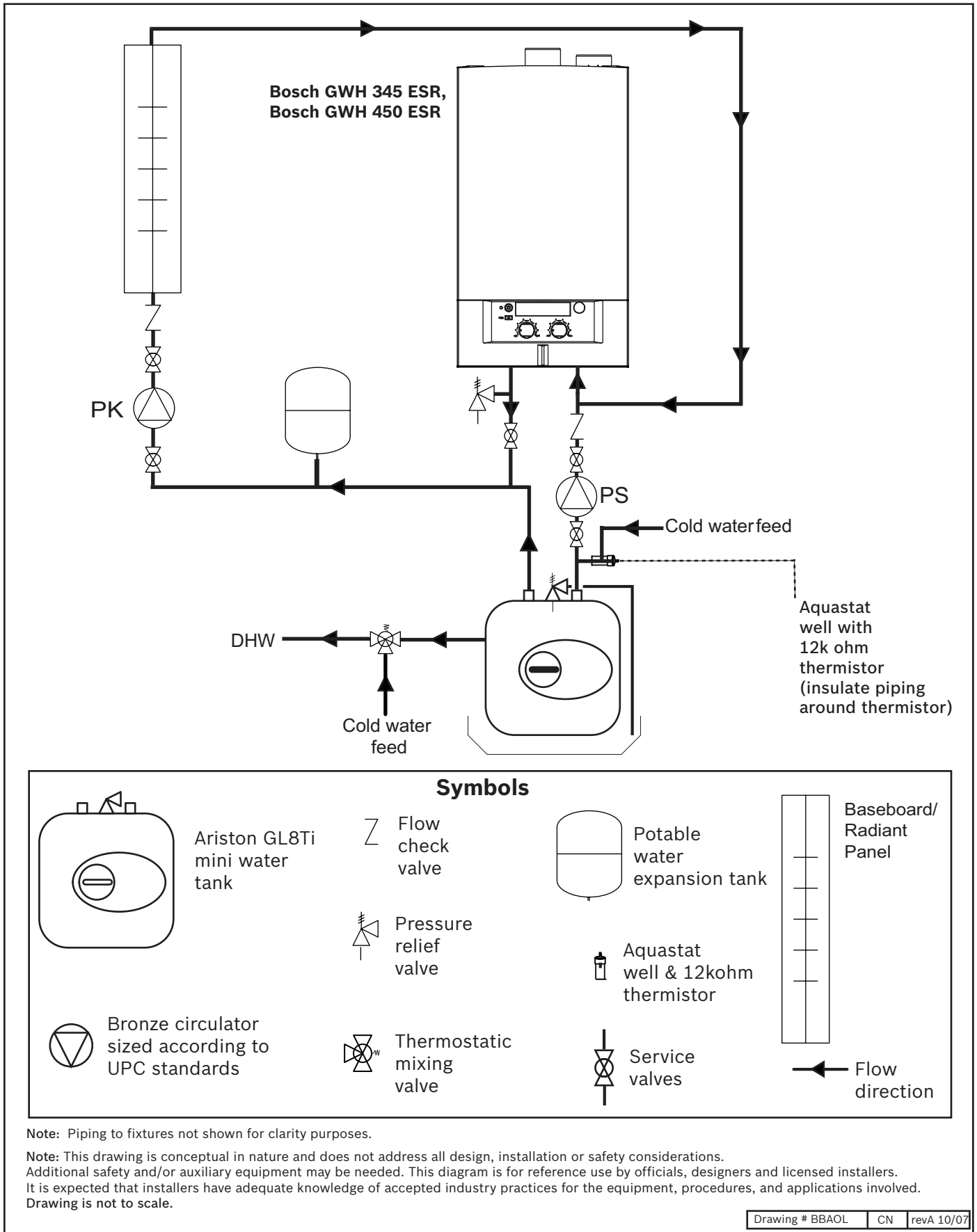

5.1.4 Baseboard/Radiant Panel space heating and DHW (with Ariston mini tank) electrical diagram

The following shows the appropriate electrical connections for plumbing diagram 5.1.4

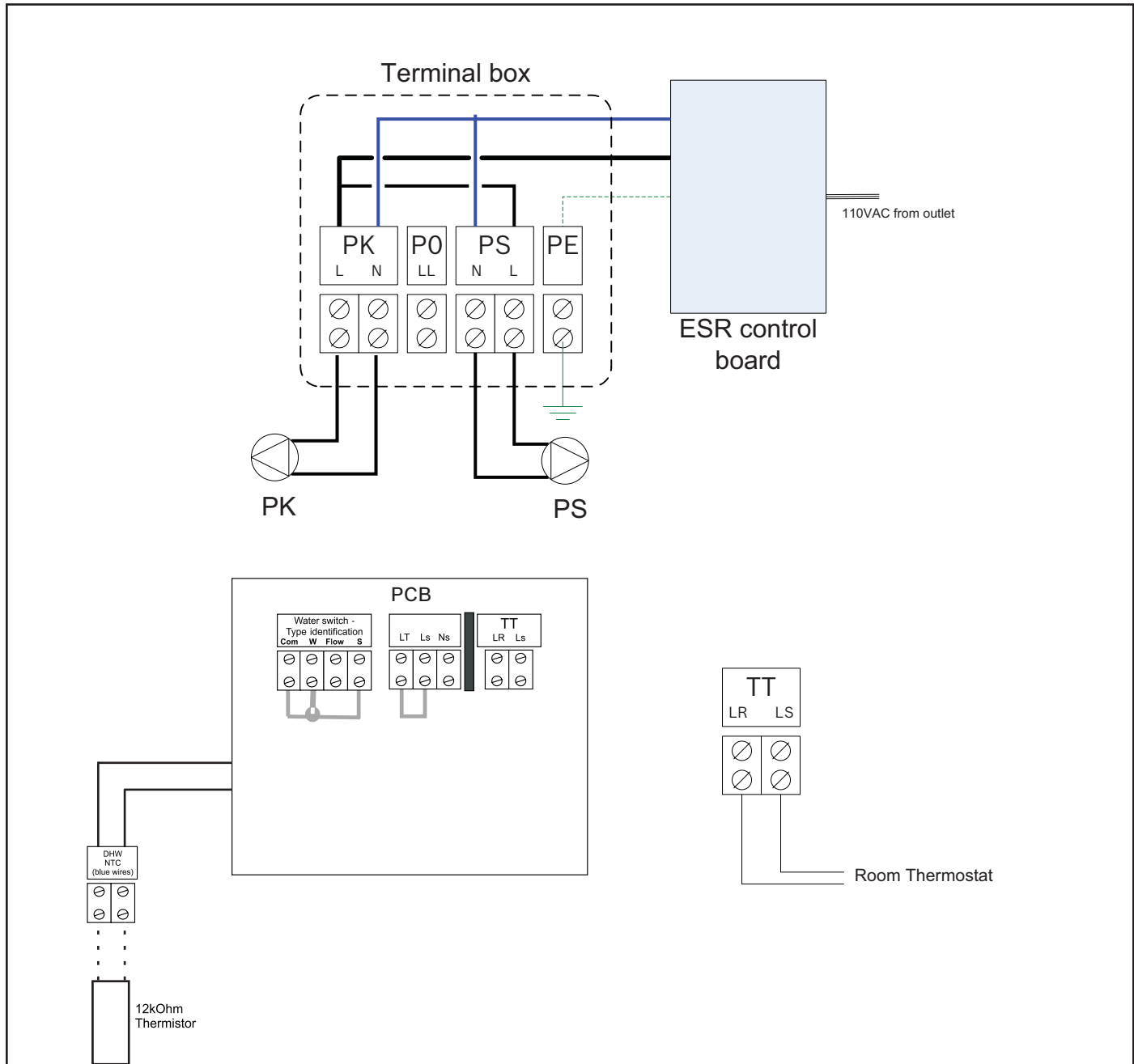

**Baseboard/Radiant Panel Space Heating and DHW (with Ariston mini tank) Electrical Diagram**

**Note:** This drawing is conceptual in nature and does not address all design, installation or safety considerations. Additional safety and/or auxiliary equipment may be needed. This diagram is for reference use by officials, designers and licensed installers. It is expected that installers have adequate knowledge of accepted industry practices for the equipment, procedures, and applications involved. Drawing is not to scale.

Drawing # EBBAOL CN revA 10/07

5.1.5 Baseboard/ Radiant Panel space heating and DHW (without storage tank) plumbing diagram

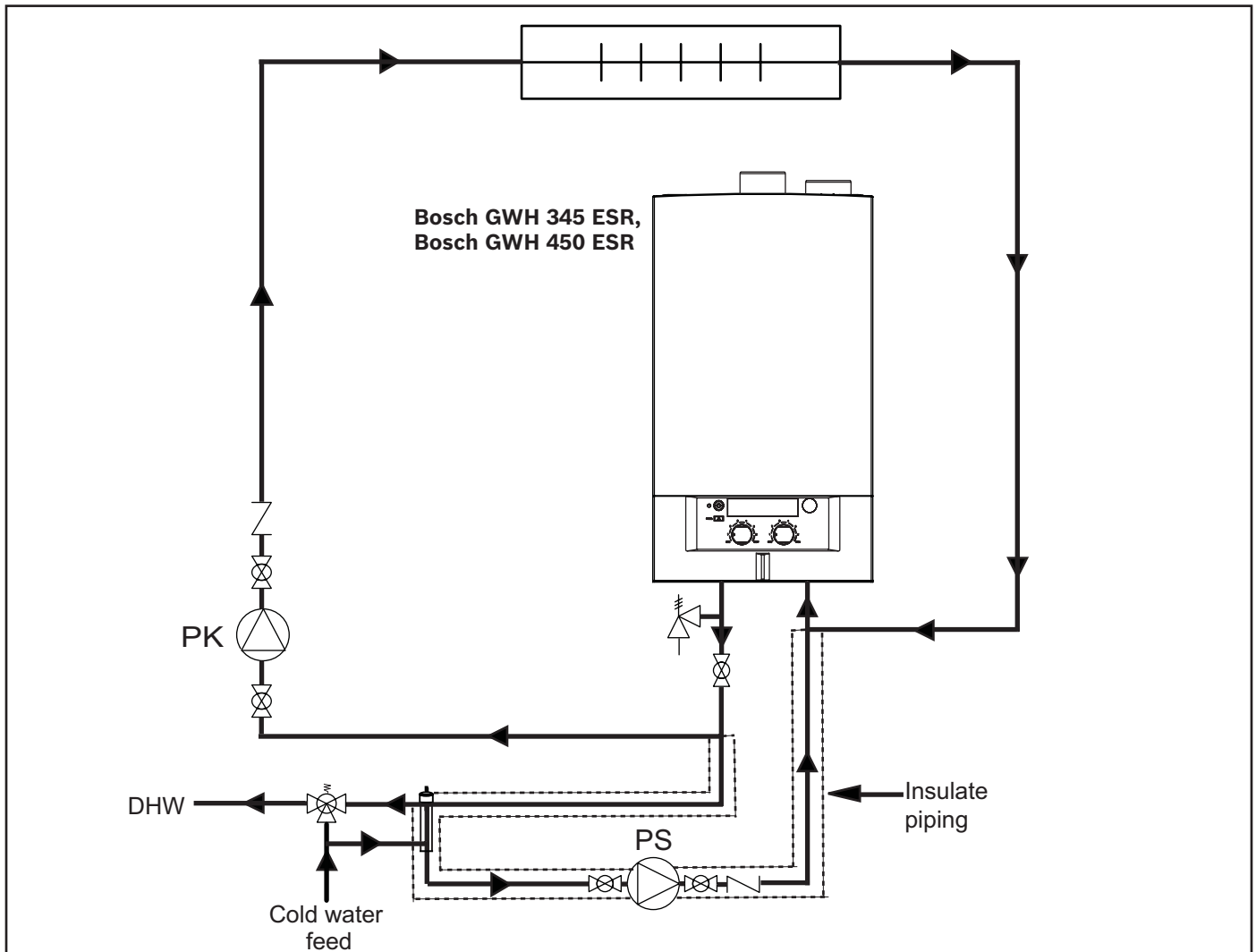

### Symbols

 Piping Insulation	 Flow check valve	 Flow direction	 Baseboard/ Radiant Panel
 Bronze circulator sized according to UPC standards	 Pressure relief valve	 Aquastat well & 12kohm thermistor	
	 Thermostatic mixing valve	 Service valves	

Note: Piping to fixtures not shown for clarity purposes.

Note: This drawing is conceptual in nature and does not address all design, installation or safety considerations. Additional safety and/or auxiliary equipment may be needed. This diagram is for reference use by officials, designers and licensed installers. It is expected that installers have adequate knowledge of accepted industry practices for the equipment, procedures, and applications involved. Drawing is not to scale.



**5.1.5 Baseboard/Radiant Panel space heating and DHW (without storage tank) electrical diagram**

The following shows the appropriate electrical connections for plumbing diagram 5.1.5

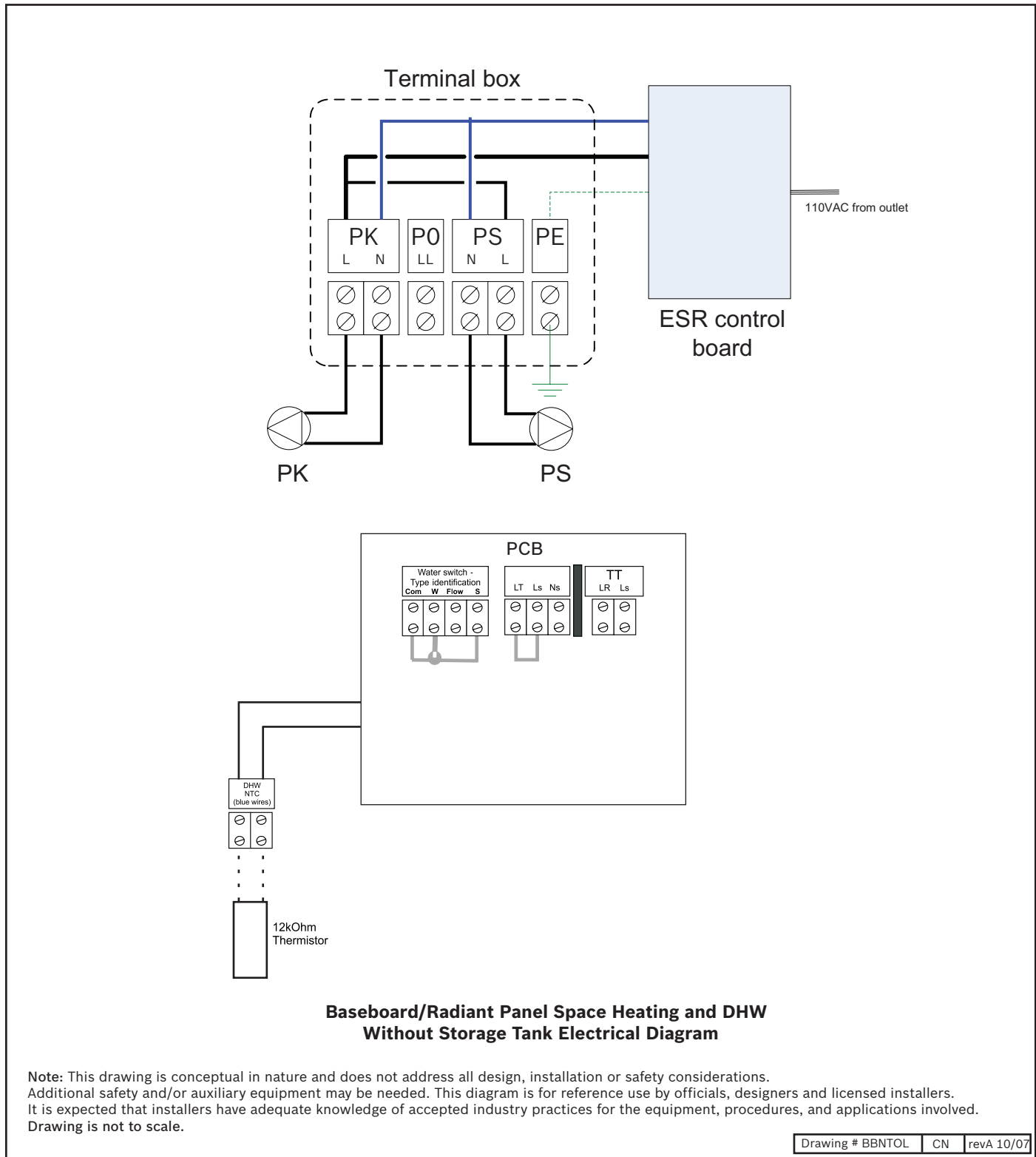

### 5.2 Indirect Tank Applications

#### 5.2.1 Indirect Baseboard/ Radiant Panel space heating and DHW plumbing diagram

Note: Not suitable for space heating applications requiring high water temperature.

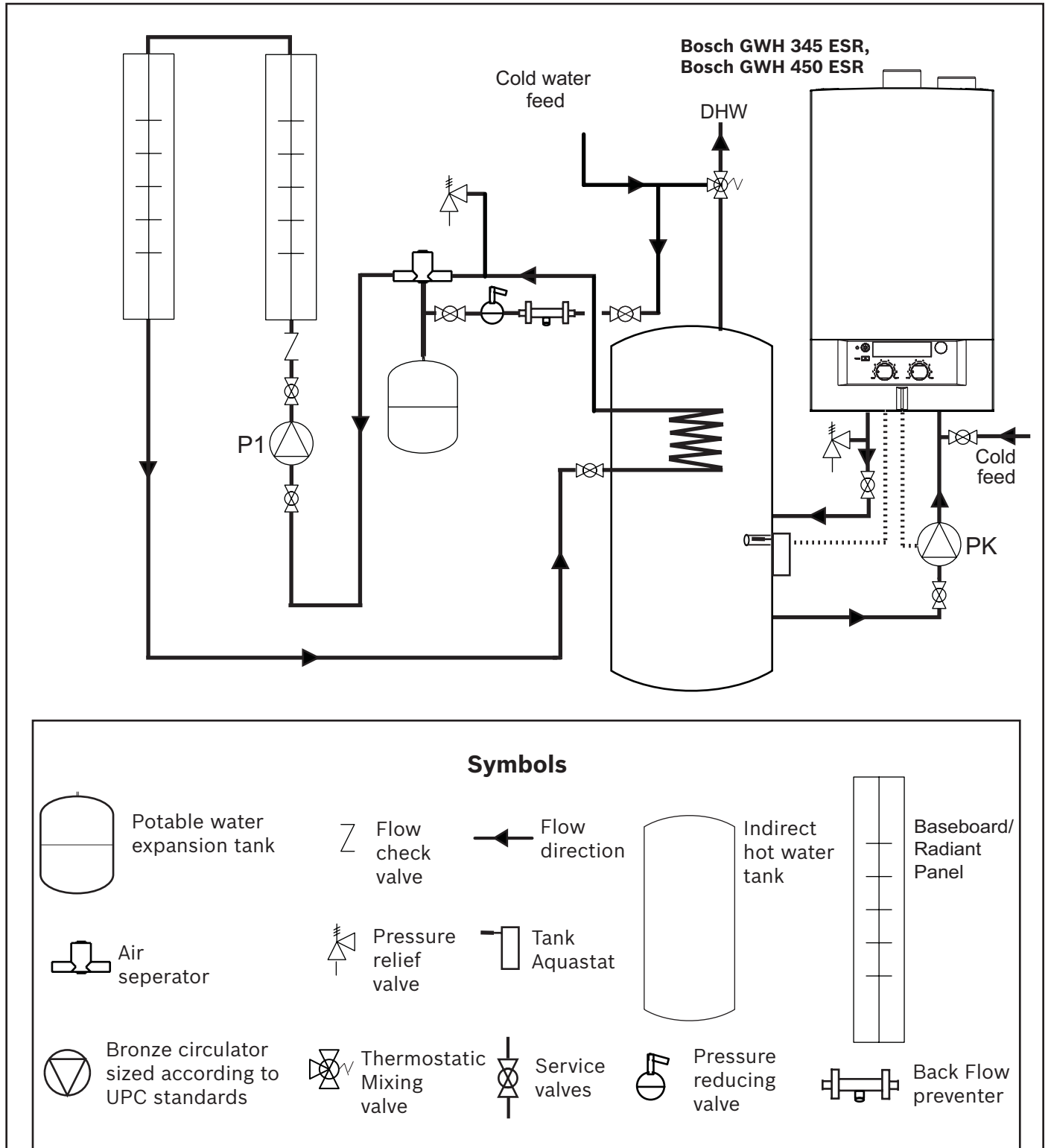

Note: Piping to fixtures not shown for clarity purposes.

Note: This drawing is conceptual in nature and does not address all design, installation or safety considerations. Additional safety and/or auxiliary equipment may be needed. This diagram is for reference use by officials, designers and licensed installers. It is expected that installers have adequate knowledge of accepted industry practices for the equipment, procedures, and applications involved. Drawing is not to scale.

**5.2.1 Baseboard/Radiant Panel space heating and DHW electrical diagram**

The following shows the appropriate electrical connections for plumbing diagram 5.2.1

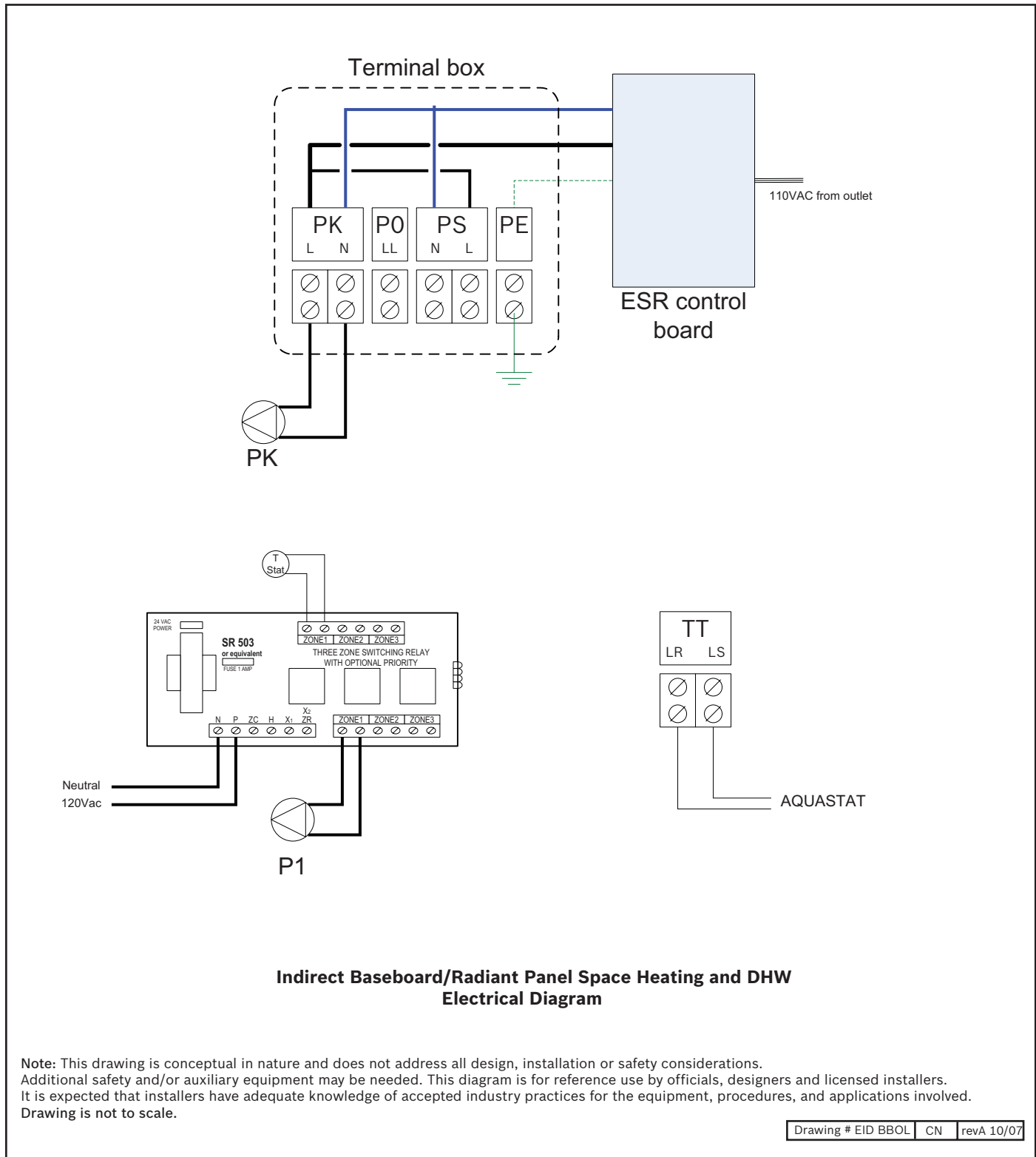

## **6 Maintenance Drawings**

Bosch appliances are designed to last for many years. In order to keep the heater operating properly, periodic maintenance is required. Please consult the installation manual for maintenance intervals. A descaling procedure drawing is included to assist in clearing the water heater of mineral deposits that may build up over time.

### **6.1 Descaling procedure**

This procedure should only be done if there is evidence of scale build-up such as a reduced hot water flow rate or if the water is known to have high levels of minerals such as calcium.

1. Disconnect electrical supply from the water heater.
2. Shut off the water supply to the water heater using (installer supplied) isolation valve.
3. Open hot water taps to drain and relieve pressure from the plumbing system.
4. Drain water from the unit's heat exchanger by disconnecting inlet and outlet water connections.
5. Connect the line (A) from the outlet of the circulating pump (installer supplied) to the inlet water fitting on the water heater.
6. Using another line (B), connect to the water outlet fitting on the water heater. Route the other end of this line into a descaling reservoir.
7. Using a 3rd line (C) from the descaling reservoir, connect to the inlet side of circulating pump. Verify there is a filter on the end of the line in the descaling reservoir.
8. Make sure all connections are "hand tight."
9. Fill tank with descaling solution so lines inside are submersed. We recommend a straight white vinegar. If using a commercial descalant, refer to manufacturer's instructions for proper dilution ratio.
11. Operate the circulating pump.
12. Make sure there are no leaks and the solution is flowing from the descaling reservoir through the heat exchanger and returning to the reservoir.
13. Run solution through the heat exchanger until the solution returning to the descaling reservoir comes out clear. (Changing to a fresh solution may be necessary during this process)
14. Disconnect all lines and drain all solution from heat exchanger. Properly discard of solution.
15. Position a container below the hot water outlet and connect cold water supply. Open cold water supply isolation valve and flush heat exchanger with clean water.
16. Shut cold water isolation valve and reconnect hot water supply to the water heater.
17. Reconnect electrical supply to unit, open water isolation valves, and return the unit to service.

## 6.1 Descaling procedure diagram

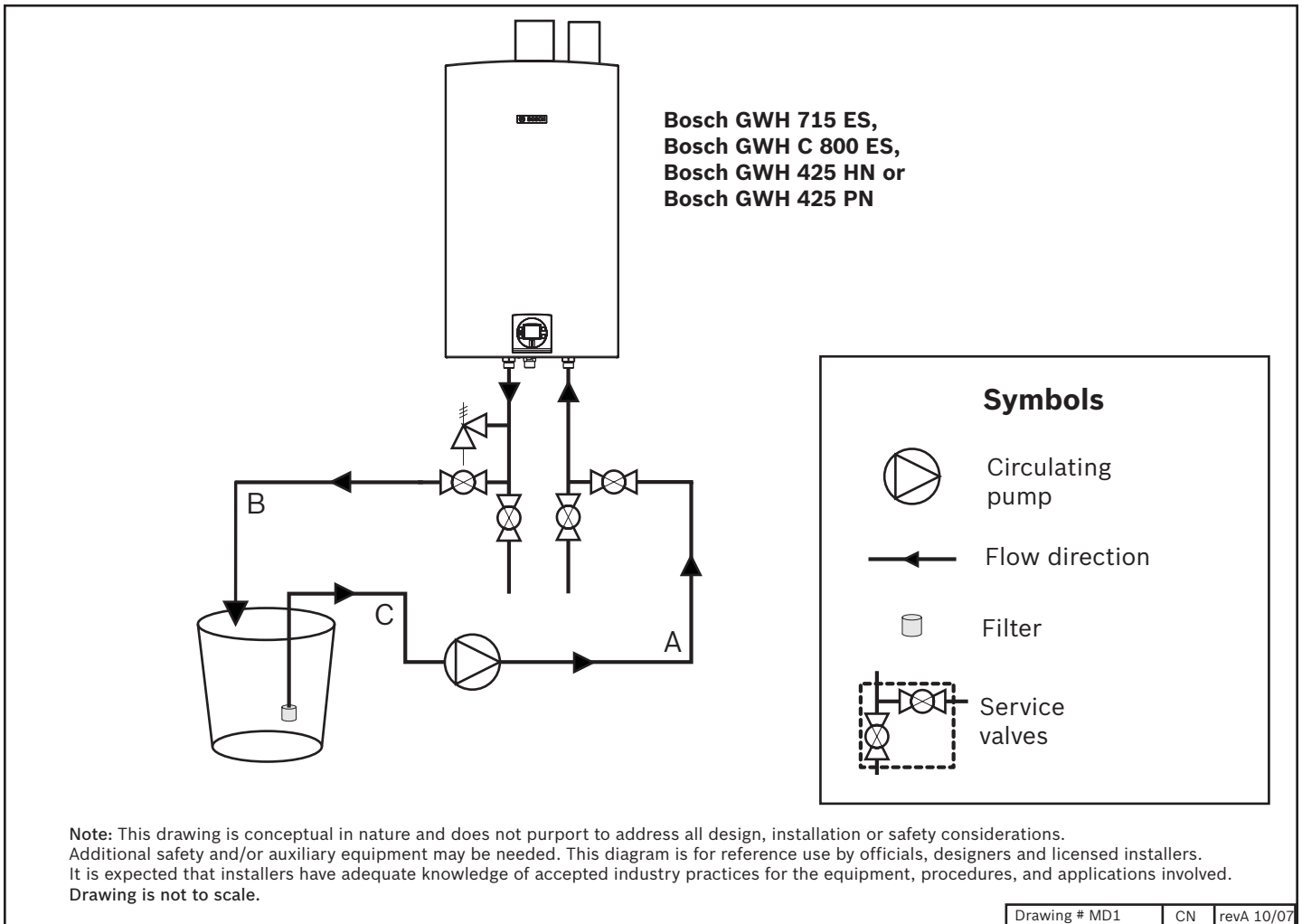











**BBT North America Corporation**

Bosch Group

Bosch Water Heating  
50 Wentworth Ave  
Londonderry, NH 03053  
Telephone (603) 882-1100  
Fax (603) 584-1681

**[www.protankless.com](http://www.protankless.com)**

**[techsupport@protankless.com](mailto:techsupport@protankless.com)**

## Free Manuals Download Website

<http://myh66.com>

<http://usermanuals.us>

<http://www.somanuals.com>

<http://www.4manuals.cc>

<http://www.manual-lib.com>

<http://www.404manual.com>

<http://www.luxmanual.com>

<http://aubethermostatmanual.com>

Golf course search by state

<http://golfingnear.com>

Email search by domain

<http://emailbydomain.com>

Auto manuals search

<http://auto.somanuals.com>

TV manuals search

<http://tv.somanuals.com>