

CARBON MONOXIDE ALARM

CAT. **CO250LBT**



TAMPER PROOF BRACKET

Locks alarm to wall to prevent removal of alarm and battery. Includes tamper proof screw and screwdriver bit.

ELECTROCHEMICAL CO SENSOR

Most accurate technology available for detecting carbon monoxide as compared to other sensing technologies

TWO SILENCE FEATURES

Silences low battery chirp for up to eight hours or silence nuisance alarm for several minutes.

END OF LIFE SIGNAL

Provides audible notice when alarm needs to be replaced.

TAMPER RESISTANT LOCKING PIN

Locks alarm cover to prevent removal of battery. Perfect for apartment, dormitory or hotel applications.

5 YEAR 9V LITHIUM BATTERY INCLUDED



BRK[®]

THE PROFESSIONAL STANDARD

9V Lithium Battery Powered

Description:

BRK Model CO250LBT is a single station carbon monoxide alarm specifically designed for residential and institutional applications including sleeping rooms of hospitals, hotels, motels, dormitories, and other multifamily dwellings as defined in standard NFPA 101. Model CO250LBT has been fully tested and complies with, UL2034, NFPA 720, and NFPA 101 and other agencies that model their codes after the above agencies. It meets building codes where battery operated carbon monoxide alarms with silence and a 5-Year tamper proof mounting bracket is required.

BRK Model CO250LBT is a state of the art carbon monoxide alarm designed to provide early warning of the presence of carbon monoxide. It features an electrochemical carbon monoxide sensor, an 85dB horn, a full function test switch and a red LED light that indicates DC power or alarm. The CO250LBT features a 9V Lithium battery that will power the alarm for at least 5 years. It also features a tamper proof mounting bracket that prevents removal of the alarm from the wall or ceiling using a tamper proof spanner screw. A tamper proof spanner screwdriver bit is also included. It also features a tamper resistant locking pin that locks alarm cover to prevent removal of battery when tamper proof bracket is removed. This alarm has two silence features. Low Battery Silence: Temporarily silence the low battery chirp for up to eight hours. Alarm Silence: Silence alarm for several minutes. Perfect for apartment, dormitory or hotel applications. The compact, low profile design complements any décor. When voltage drops to a pre-set warning level, the horn will "chirp" approximately once per minute to indicate a fresh battery is needed. To insure the battery is always replaced properly, the cover is designed to resist closing when the battery is missing. Designed for wall or ceiling mounting.

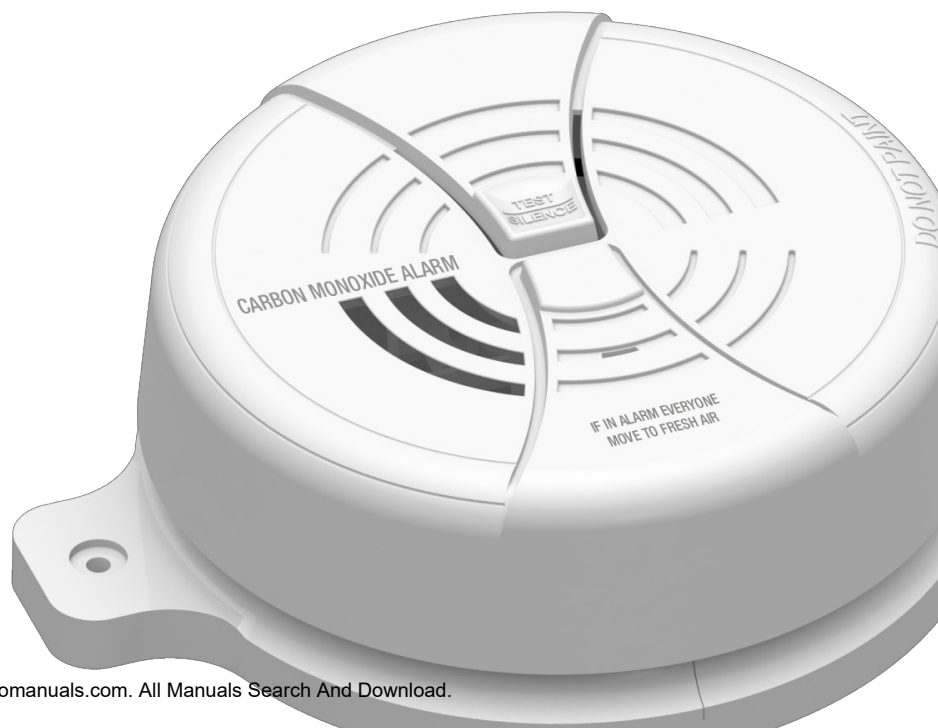

CAT. C0250LBT

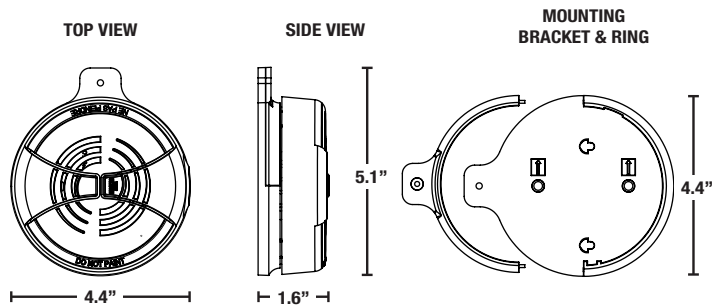

ARCHITECTURAL AND ENGINEERING SPEC

The carbon monoxide alarm shall be a BRK Model C0250LBT and shall provide at a minimum the following features and functions:

1. An electrochemical CO sensor.
2. The unit shall be capable of self restoring.
3. The unit shall have an "End of Life" signal. This signal should be capable of temporarily being silenced for up to 2 days. After about 2 days, the signal will resume. After about 2-3 weeks the signal cannot be silenced.
4. Powered by a supervised 9V Lithium battery that will power the alarm for at least 5 years and a solid state piezo horn rated at 85dB at 10 ft.
5. A visual LED power-on indicator to confirm unit is receiving power or is in alarm.
6. A test/silence button to check all alarm functions and to silence any nuisance alarms. In addition, the unit shall have a low battery silence feature to quiet the low battery chirp for up to eight hours.
7. A tamper proof mounting bracket that prevents removal of the alarm from the wall or ceiling using a tamper proof spanner screw. A tamper proof spanner screwdriver bit is to be provided. In addition a tamper resistant locking pin should be provided that locks alarm cover to prevent removal battery.
8. The CO sensor is adjusted not to detect CO levels below 30 PPM and will not alarm when exposed to constant levels of 30 PPM for 30 days. It will alarm at the following levels: 400 PPM CO between 4 and 15 minutes, 150 PPM CO between 10 and 50 minutes and 70 PPM CO between 60 and 240 minutes.
9. The unit shall be capable of operating between 40°F (4°C) and 100°F (38°C) and relative humidity between 10% and 95%.
10. The unit shall contain mounting hardware and shall be listed for wall or ceiling mounting.
11. The unit shall at a minimum meet the requirements of UL2034, NFPA 720, NFPA 101, ICC.

INSTALLATION OF ALARM

Installation of this CO alarm must conform to NFPA 720. Always check your local building codes. Follow all instructions for placement as outlined in the user's manual in sections titled "Recommended Locations for CO Alarms" and "Locations to Avoid for CO Alarms".

THE PARTS OF THIS CO ALARM

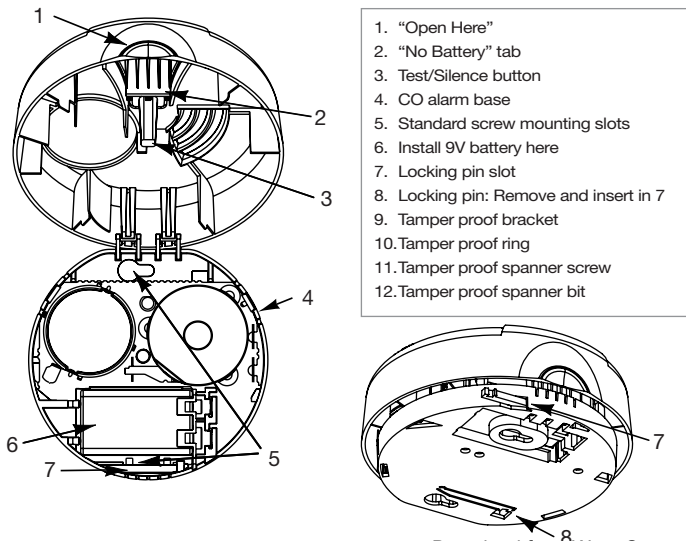

TECHNICAL SPECS

Alarm Dimensions:	5.1"W x 4.38"H x 1.64"D
Weight:	6.3 oz
Operating Voltage:	9V Lithium Battery Powered
Temperature Range:	40°F (4°C) to 100°F (38°C)
Humidity Range:	10% to 90% relative humidity (RH)
Audio Alarm:	85dB at 10 feet
Test/Silence:	Electronically simulates carbon monoxide condition, causing the unit to alarm. Press and hold test/silence button
Alarm Reset:	Automatic when CO clears
CO Sensor:	Electrochemical
Indicator Lights/Sounds:	
DC Power:	Intermittent Red LED
Local Alarm:	Audio alarm and rapidly flashing Red LED
Listing:	Listed to UL2034 Standard

SHIPPING SPECS

Individual Carton Dimensions	4.38"L x 1.88"W x 4.57"H
Weight	0.50 lbs.
Cube	0.02 ft ³
UPC	0 29054 00952 4
Master Carton Dimensions	12.63"L x 6.13"W x 5.19"H
Master Pack	6
Weight	3.24 lbs.
Cube:	0.23 ft ³
I2of5:	600 29054 00952 6
Pallet Information	
Cases per Layer	30
Number of Layers:	8
Cases per Pallet:	240
Units per Pallet:	1440
Cube:	45.1 ft ³
Weight:	843 lbs.

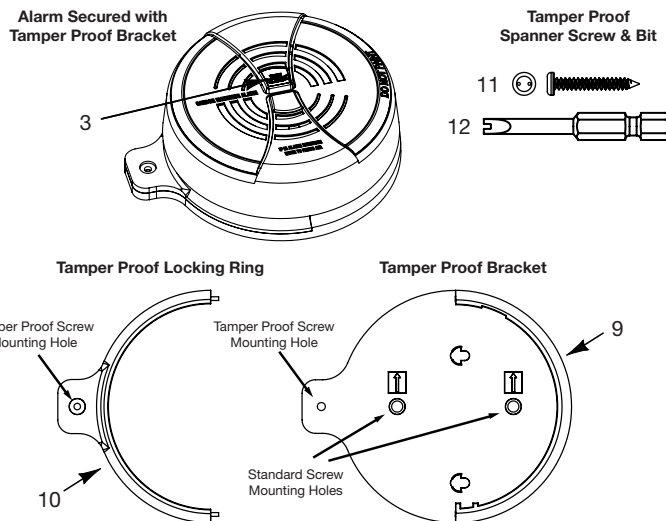

©2011 BRK Brands, Inc. a Jarden Corporation Company (NYSE: JAH)
3901 Liberty Street Road
Aurora, IL 60504-8122
All rights reserved

First Alert is a registered trademark of the First Alert Trust
BRK is a registered trademark of BRK Brands, Inc.
CM3117

Free Manuals Download Website

<http://myh66.com>

<http://usermanuals.us>

<http://www.somanuals.com>

<http://www.4manuals.cc>

<http://www.manual-lib.com>

<http://www.404manual.com>

<http://www.luxmanual.com>

<http://aubethermostatmanual.com>

Golf course search by state

<http://golfingnear.com>

Email search by domain

<http://emailbydomain.com>

Auto manuals search

<http://auto.somanuals.com>

TV manuals search

<http://tv.somanuals.com>