

**BRK** ELECTRONICS®

**MODEL CO5120PDB—USER'S MANUAL**  
**AC POWERED CARBON MONOXIDE ALARM**  
**WITH BATTERY BACK-UP AND**  
**DIGITAL DISPLAY**

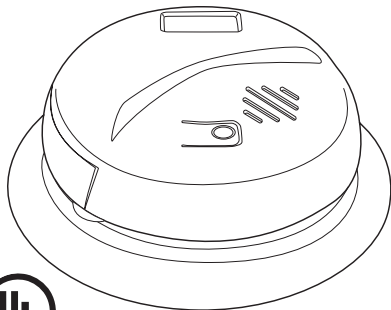

120VAC 60 Hz 0.09A

Model  
CO5120PDB

**PLEASE READ CAREFULLY AND SAVE:**

**This unit was shipped with a user's manual that contains important information about its operation. If you are installing this unit for use by others, you must leave this manual—or a copy of it—with the user.**

**FEATURES**

This CO Alarm is designed to be hard-wired and mounted on any standard size junction box, up to 4" size. 120V AC power to the junction box must not be controlled by a dimmer or switch (other than a circuit breaker).

This CO Alarm samples the air and takes a new reading about every second. A microchip inside the unit stores each reading, and remembers the levels of CO it has been exposed to over time. The unit goes into alarm mode when it has been exposed to a "critical" level of CO (measured in parts per million or "ppm") within a specified time (measured in minutes).

**General features:** This Alarm features a permanently installed sensor, a red indicator light (LED), and an 85 dB alarm horn.

**9V Battery Back-Up.** If AC power is interrupted, the CO Alarm will continue to operate for a short time, provided the 9V battery is fresh and correctly installed.

**Silence Feature.** The Silence feature temporarily quiets the alarm.

**Low Battery Silence Feature.** Temporarily silences the Low Battery Warning "chirp" for up to 8 hours if AC power is present.

**Digital Display.** Shows levels of CO, measured in parts per million present and any stored peak levels.

**Malfunction Warning.** This unit performs self-diagnostic tests approximately every second. If the alarm malfunctions, it should be replaced immediately.

# TABLE OF CONTENTS

<b>Chapter 1: Introduction</b> . . . . .	<b>Inside Cover</b>
Basic Safety Information . . . . .	Inside Cover
How Your CO Alarm Works . . . . .	1
Understanding Your CO Alarm . . . . .	2
Using the CO Memory . . . . .	4
CO Alarm Specifications . . . . .	5
<b>Chapter 2: Installation</b> . . . . .	<b>6</b>
Where to Install CO Alarms . . . . .	6
Where NOT To Install CO Alarms . . . . .	7
Using the Locking Features . . . . .	8
How to Install Your CO Alarm . . . . .	11
<b>Chapter 3: If Your CO Alarm Sounds</b> . . . . .	<b>17</b>
If the Alarm Sounds . . . . .	17
Using the Silence Feature . . . . .	18
Finding the Source of CO After an Alarm . . . . .	19
The Latching Alarm Indicator . . . . .	19
<b>Chapter 4: Testing and Maintenance</b> . . . . .	<b>20</b>
<b>Chapter 5: What You Need To Know About CO</b> .21	
What is CO? . . . . .	21
Symptoms of CO Poisoning . . . . .	21
Finding the Source of CO After an Alarm . . . . .	21
Potential Sources Of CO In The Home . . . . .	22
How Can I Protect My Family? . . . . .	23
<b>Chapter 6: Underwriters Laboratories, Inc.</b>	
<b>UL2034</b> . . . . .	<b>24</b>
<b>Chapter 7: Troubleshooting Guide</b> . . . . .	<b>25</b>
<b>Chapter 8: General Limitations</b>	
<b>Of CO/Smoke Alarms</b> . . . . .	<b>26</b>
<b>Limited Warranty</b> . . . . .	<b>27</b>

# CHAPTER 1: INTRODUCTION

## **BASIC SAFETY INFORMATION**

### **IMPORTANT!**

Dangers, Warnings, and Cautions alert you to important operating instructions or to potentially hazardous situations. Pay special attention to these items.

### **IMPORTANT!**

**THIS IS NOT A SMOKE ALARM! This CO Alarm is designed to detect carbon monoxide from ANY source of combustion. It is NOT designed to detect smoke, fire, or any other gas.**

### **IMPORTANT!**

This CO Alarm is approved for use in single-family residences. It is NOT designed for marine or RV use.

### **CAUTION!**

This CO Alarm will only indicate the presence of carbon monoxide gas at the sensor. Carbon monoxide gas may be present in other areas.

### **WARNING!**

The Silence Feature is for your convenience only and will not correct a CO problem. Always check your home for a potential problem after any alarm. Failure to do so can result in injury or death.

### **WARNING!**

This unit does not work without power. If the AC power fails, the battery back-up will power the alarm for at least 20 hours provided the 9V battery is fresh and correctly installed.

Basic safety information (continued)...

### **⚠WARNING!**

NEVER ignore any alarm. Refer to Chapter 3 for more information on how to respond to an alarm. Failure to respond can result in injury or death.

### **⚠WARNING!**

Test this Carbon Monoxide Alarm once a week. If it ever fails to test correctly, have it replaced immediately! If the alarm is not working properly, it cannot alert you to a problem.

### **⚠CAUTION!**

Do not paint over the CO Alarm. Paint may clog the openings to the sensing chamber and prevent the sensors from operating properly.

### **⚠CAUTION!**

This product is intended for use in ordinary indoor locations of family living units. It is not designed to measure CO levels in compliance with Occupational Safety and Health Administration (OSHA) commercial or industrial standards. Individuals with medical conditions may consider using warning devices which provide audible and visual signals for carbon monoxide concentrations under 30 ppm.

### **⚠WARNING!**

Disconnect AC power before changing battery. Shock hazard exists if AC power is miswired.

## **HOW YOUR CO ALARM WORKS**

### **THE COVER OF YOUR CO ALARM**

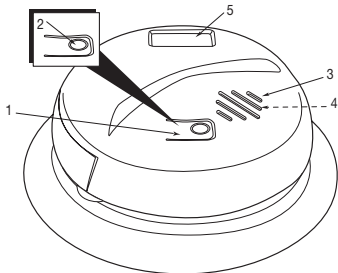

1. Test/Silence/Scroll Button: Press and release to select mode (Test, Memory, Clear Memory); Press and hold to activate mode, or to silence the alarm.
2. POWER/ALARM Light (RED)
3. Air Vents
4. (Behind the Cover) Alarm Horn: 85db audible alarm for test, alarm, and unit malfunction warning.
5. Digital Display



# UNDERSTANDING YOUR CO ALARM

## BASIC POWER CONDITIONS



 <p>READY</p> <p>TEST MEMORY CLEAR MEMORY</p>	 <p>READY</p> <p>TEST MEMORY CLEAR MEMORY</p>	 <p>READY</p> <p>TEST MEMORY CLEAR MEMORY</p>
<p><b>Alarm operating on AC power</b></p>	<p><b>Alarm operating on emergency battery back-up</b></p>	<p><b>Low / missing battery warning</b></p>

## WHAT YOU SEE AND HEAR DURING INSTALLATION

Under normal conditions (AC power)



	<p><b>Horn</b></p>	<p>Silent</p>
 <p>READY</p> <p>TEST MEMORY CLEAR MEMORY</p>	<p><b>Display</b></p>	<p>Dash remains lit at "READY"</p>
	<p><b>POWER/ALARM Light</b></p>	<p>Shines continuously</p>

When you test the CO Alarm



	<p><b>Horn</b></p>	<p>Sounds loudly - 4 beeps, pause, 4 beeps, pause</p>
 <p>READY</p> <p>TEST MEMORY CLEAR MEMORY</p>	<p><b>Display</b></p>	<p>Flashes "888" briefly</p>
	<p><b>POWER/ALARM Light</b></p>	<p>Flashes once per second</p>

## WHAT YOU SEE AND HEAR UNDER DIFFERENT CONDITIONS

During a power failure (in battery back-up)

	<p><b>Horn</b></p>	<p>Chirps briefly</p>
 <p>READY</p> <p>TEST MEMORY CLEAR MEMORY</p>	<p><b>Display</b></p>	<p>The word "bat" is displayed</p>
	<p><b>POWER/ALARM Light</b></p>	<p>Flashes once a minute</p>



When the electricity comes back on

	<p><b>Horn</b></p>	<p>Chirps briefly</p>
 <p>READY</p> <p>TEST MEMORY CLEAR MEMORY</p>	<p><b>Display</b></p>	<p>Dash appears by "READY" within a minute</p>
	<p><b>POWER/ALARM Light</b></p>	<p>Shines Continuously</p>

*Continued...*

## What You See and Hear Under Different Conditions (continued)...

### If battery becomes low or is missing



	<b>Horn</b>	Chirps once a minute*
	<b>Display</b>	The word "bat" flashes on and off
	<b>POWER/ALARM Light</b>	Flashes once a minute

\*Note: If the battery becomes very weak, you will hear extra "chirps." Replace the battery immediately!

### **⚠WARNING!**



Disconnect AC power before changing battery. Shock hazard exists if AC power is miswired.

### If the CO alarm is not operating properly



	<b>Horn</b>	Three rapid chirps every minute
	<b>Display</b>	Displays "Err"
	<b>POWER/ALARM Light</b>	Flashes three times in sync with the horn

## WHAT YOU SEE AND HEAR IF CO IS DETECTED

### Pre-Alarm Levels

	<b>Horn</b>	Silent
	<b>Display</b>	Shows CO levels detected in ppm
	<b>POWER/ALARM Light</b>	Shines continuously

### Alarm levels of CO are detected (Over 70 ppm)



	<b>Horn</b>	Sounds loudly - 4 beeps, pause, 4 beeps, pause. This sequence repeats for as long as the unit is in alarm*
	<b>Display</b>	Shows CO levels detected in ppm
	<b>POWER/ALARM Light</b>	Flashes once per second

\*Note: If unit goes into alarm under battery back-up power, the regular 4 beeps-brief pause cycle will repeat for four minutes. After four minutes, the pause will increase to 1 minute.

*Continued)...*



## What You See and Hear If CO Is Detected (continued)...

### If you silence the alarm

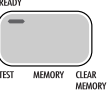

	<b>Horn</b>	Silent for about 4 minutes*
	<b>Display</b>	Shows CO levels detected in ppm
	<b>POWER/ALARM Light</b>	Flashes once per second

**\*Note:** After 4 minutes, if CO levels drop below alarm levels, the unit will remain silent and return to normal operation. If CO present still indicates a potentially dangerous situation, the horn will sound again. If CO levels increase during the silence period, the horn will resume sounding.

### If alarm levels of CO are detected by an interconnected (remote) alarm

	<b>Horn</b>	Sounds loudly - 4 beeps, pause, 4 beeps, pause. This sequence repeats for as long as the remote unit is in alarm*
	<b>Display</b>	Dash remains lit at "READY"
	<b>POWER/ALARM Light</b>	Shines continuously

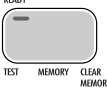
## The "Latching Alarm" Indicator

	<b>Horn</b>	Silent
	<b>Display</b>	Dash remains lit at "READY"
	<b>POWER/ALARM Light</b>	Flashes once every 5 sec., on initiating unit in an interconnected series

## USING THE CO MEMORY

The CO Memory Feature lets you check the highest level of CO recorded.

### To check CO Memory:

1. Press and release the Test/Silence/Scroll button until dash scrolls to "MEMORY."
2. Press and hold Test/Silence/Scroll button to display Memory CO level.



### To clear CO Memory:

1. Press and release the Test/Silence/Scroll button until the dash scrolls to "CLEAR MEMORY."
2. Press and hold the Test/Silence/Scroll button until the display shows "CLr."



**NOTE:** The highest CO level will be saved, even after a power interruption, until you clear it. DO NOT clear the CO Memory reading if you plan to call someone to investigate a CO problem! Clear the CO Memory reading only after the investigator has checked your home.

## CO ALARM SPECIFICATIONS

---

### Gas Detection at Typical Temperature and Humidity Ranges:

The CO Alarm is not formulated to detect CO levels below 30 ppm typically. UL tested for false alarm resistance to Methane (500 ppm), Butane (300 ppm), Heptane (500 ppm), Ethyl Acetate (200 ppm), Isopropyl Alcohol (200 ppm) and Carbon Dioxide (5000 ppm). Values measure gas and vapor concentrations in parts per million.

**Required Alarm Levels:** Before 10% COHb exposure at levels of 30% to 70% Relative Humidity (RH):

- 400 ppm CO between 4 and 15 minutes
- 150 ppm CO between 10 and 50 minutes
- 70 ppm CO between 60 and 240 minutes

When exposed to a constant level of 30 ppm of CO, this CO Alarm was tested not to go into alarm for at least 30 days.

**Audible Alarm:** 85dB minimum at 10 feet.

**Power:** Powered by 120VAC. The 9V battery back-up provides 8 hours of standby and sounds alarm for 12 hours with fresh battery. When AC power is on, red light (LED) shines continuously. Under battery power, red light flashes once a minute.

**Malfunction:** Horn chirps and light blinks 3 times (in rapid succession) every minute and digital display shows "Err".

**Dimensions:** 5.4" diameter (approx.)

**Supply Voltage:** 120VAC 60Hz, 0.09A.

**During Alarm:** Repeating alarm horn pattern:  
4 beeps, pause, 4 beeps, pause.

- Stand-alone unit: red light (LED) flashes once per second.
- Interconnected series: red light (LED) flashes once per second on the Initiating alarm. The red light (LED) on all other alarms will shine continuously.

**Warranty:** 5-year limited warranty.

**Standards:** Underwriters Laboratories Inc. Single and Multiple Station carbon monoxide alarms UL2034.

According to Underwriters Laboratories Inc. UL2034, Section 1-1.2: "Carbon monoxide alarms covered by these requirements are intended to respond to the presence of carbon monoxide from sources such as, but not limited to, exhaust from internal-combustion engines, abnormal operation of fuel-fired appliances, and fireplaces. CO alarms are intended to alarm at carbon monoxide levels below those that could cause a loss of ability to react to the dangers of Carbon Monoxide exposure." This CO Alarm monitors the air, and is designed to alarm before CO levels become life threatening. This allows you precious time to leave the house and correct the problem. This is only possible if alarms are located, installed, and maintained as described in this manual.

# CHAPTER 2: INSTALLATION

## WHERE TO INSTALL CO ALARMS

The National Fire Protection Association (NFPA) recommends that a CO Alarm should be centrally located outside of each separate sleeping area in the immediate vicinity of the bedrooms. For added protection, install additional CO Alarms in each separate bedroom, and on every level of your home.

If your bedroom hallway is longer than 40 feet, install a CO Alarm at BOTH ends of the hallway.

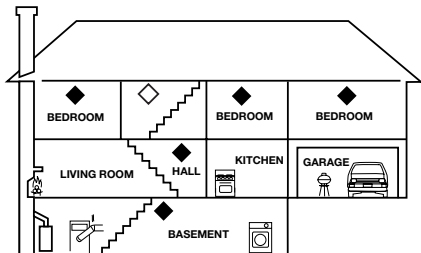

◇ REQUIRED TO MEET NFPA RECOMMENDATIONS

◆ SUGGESTED AREAS FOR INSTALLING ADDITIONAL CO ALARMS

## IN A SINGLE-LEVEL HOME:

- Install at least one CO Alarm near or within each separate sleeping area.
- For added protection, install an additional CO Alarm at least 20 feet (6 meters), where possible\*, away from the furnace or fuel burning heat source.

## IN A MULTI-LEVEL HOME:

- Install at least one CO Alarm near or within each separate sleeping area.
- For added protection, install at least one CO Alarm on each level of the home. If you have a basement, install that CO Alarm at the top of the basement stairs.
- For added protection, install an additional CO Alarm at least 20 feet (6 meters), where possible\*, away from the furnace or fuel burning heat source.

(\*)In smaller homes or in manufactured homes and RV's where this distance cannot be maintained, install the Alarm as far away from the furnace or other fuel burning source. Installing the Alarm closer than 20 feet (6 meters) will not harm the Alarm, but may increase the frequency of nuisance alarms.

## ⚠WARNING!

This Alarm must have AC or battery power to operate. If the AC power fails, the battery backup will power the Alarm for a short time if the 9V battery is fresh and correctly installed. If AC power fails, and the battery is dead or missing, the Alarm cannot operate.



## **WHERE NOT TO INSTALL THIS ALARM**

### ***DO NOT locate this CO Alarm:***

- In garages, kitchens, furnace rooms, crawl spaces and unfinished attics. Avoid extremely dusty, dirty or greasy areas.
- The CO Alarm should be at least 5 feet (2 meters), preferably 20 feet (6 meters) from sources of combustion particles such as stoves, furnaces, and vehicles.
- Avoid poorly ventilated kitchens, garages, and furnace rooms.
- In extremely humid areas. This alarm should be at least 10 feet (3 meters) from a shower, sauna, humidifier, vaporizer, dishwasher, laundry room, utility room, or other source of high humidity.
- Where the temperatures are regularly below 40° F (4°C) or above 100° F (38° C) including unheated buildings, outdoor rooms, porches, or unfinished attics or basements. Extreme temperatures may shorten component or battery life.
- In turbulent air, like near ceiling fans or open windows. Blowing air may prevent CO from reaching the sensors.
- In direct sunlight.

### **⚠WARNING!**

This CO Alarm is designed for use inside a single-family home or apartment. It is not meant to be used in common lobbies, hallways, or basements of multi-family buildings unless working CO Alarms are also installed in each family living unit. CO Alarms in common areas may not be heard from inside individual family living units.

### **⚠WARNING!**

This CO Alarm alone is not a suitable substitute for complete detection systems in places which house many people, like hotels or dormitories, unless a CO Alarm is also placed in each unit.

### **⚠WARNING!**

**DO NOT use this CO Alarm in warehouses, industrial or commercial buildings, special-purpose non-residential buildings, RVs, boats, or airplanes. This CO Alarm is specifically designed for residential use, and may not provide adequate protection in non-residential applications.**

## USING THE OPTIONAL LOCKING FEATURES

The optional locking features are designed to prevent unauthorized removal of the battery or alarm. It is not necessary to activate the locks in single-family households where unauthorized battery or alarm removal is not a concern.

These CO Alarms have two separate locking features: one locks the battery compartment, and the other locks the CO Alarm to the mounting bracket. You can choose to use either feature independently, or use them both.

**Tools you will need:**

- Needle-nose pliers
- Standard/Flathead screwdriver.

Both locking features use locking pins, molded into the mounting bracket. Using needle nose pliers or a utility knife, remove one or both pins, depending on which locking features you use.

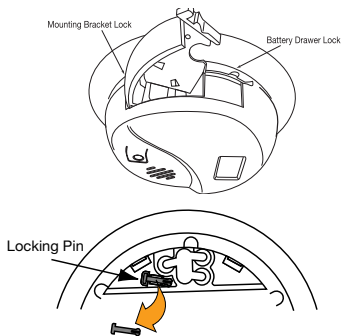

## THE BATTERY COMPARTMENT LOCK: TO LOCK THE BATTERY COMPARTMENT

### IMPORTANT!

Do not lock the battery compartment until you have activated the battery and tested the battery back-up.

1. Activate the battery back-up by removing the "Pull to Activate Battery Back-Up" tab. Push and hold the test button on the CO Alarm's cover until the alarm sounds: 4 beeps, pause, 4 beeps, pause.



**If the unit does not alarm during testing, DO NOT lock the battery compartment! Install a new battery and test again. If it still does not alarm, replace the CO Alarm immediately.**

2. Using needle-nose pliers or a utility knife, detach one locking pin from the mounting bracket.

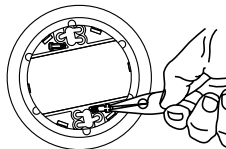

*Continued on next page...*

### To Lock the Battery Compartment (continued)...

3. Push the locking pin through the black dot on the label on the back of the CO Alarm.

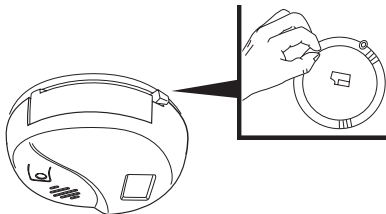

1. Remove the CO Alarm from the mounting bracket. If the unit is locked to the bracket, see the section "To Deactivate the Locking Feature."
2. Disconnect the power connector by gently prying it away from the back of the CO Alarm.
3. Insert a flathead screwdriver under the head of the locking pin, and gently pry it out of the battery compartment lock. (If you plan to re-lock the battery compartment, save the locking pin.)

### TO UNLOCK THE BATTERY COMPARTMENT:

#### **IMPORTANT!**

Once the CO Alarm is installed, you must disconnect it from the AC power before unlocking the battery compartment.

#### **⚠ DANGER!**

**ELECTRICAL SHOCK HAZARD.** Turn off the power to the area where the CO Alarm is installed before removing it from the mounting bracket. Failure to turn off the power first may result in serious electrical shock, injury or death.

#### **⚠ WARNING!**

Always discharge the branch circuit before servicing an AC or AC/DC CO Alarm. First, turn off the AC power at the circuit breaker or fuse box. Next, remove the battery from CO Alarms with battery back-up. Finally, press and hold the test button for 5-10 seconds to discharge the branch circuit.

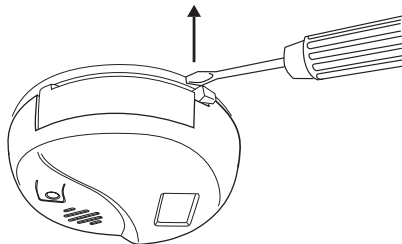

4. To re-lock the battery compartment, close the battery door and reinsert the locking pin in the lock.
5. Reconnect the power connector to the back of the CO Alarm, reattach the CO Alarm to the mounting bracket, and restore the power

#### **IMPORTANT!**

When replacing the battery, always test the CO Alarm before re-locking the battery compartment.

## THE MOUNTING BRACKET LOCK

### Tools you will need:

- Needle-nose pliers
- Standard/Flathead screwdriver

### TO ACTIVATE THE BRACKET LOCK:

1. Using needle-nose pliers, detach one locking pin from the mounting bracket.

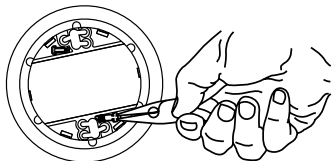

2. Insert the locking pin into the lock located on the pivoting hinge of the battery door.

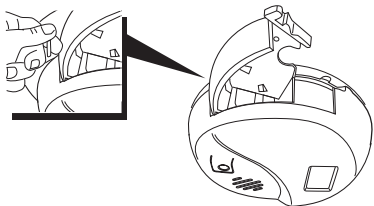

3. When you attach the CO Alarm to the mounting bracket, the locking pin's head will fit into a notch on the bracket.

### TO DEACTIVATE THE BRACKET LOCK:

#### **⚠WARNING!**

**ELECTRICAL SHOCK HAZARD.** Turn off the power to the area where the CO Alarm is installed before removing it from the mounting bracket. Failure to turn off the power first may result in serious electrical shock, injury or death.

#### **⚠WARNING!**

Always discharge the branch circuit before servicing an AC or AC/DC CO Alarm. First, turn off the AC power at the circuit breaker or fuse box. Next, remove the battery from CO Alarms with battery back-up. Finally, press and hold the test button for 5-10 seconds to discharge the branch circuit.

1. Insert a flathead screwdriver between the mounting bracket pin and the mounting bracket.

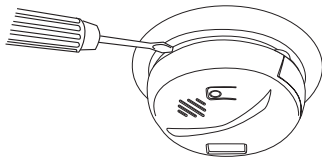

*Continued on next page...*

### To Deactivate the Bracket Lock (continued)...

2. Pry the CO Alarm away from the bracket by turning both the screwdriver and the CO Alarm counterclockwise (left) at the same time.

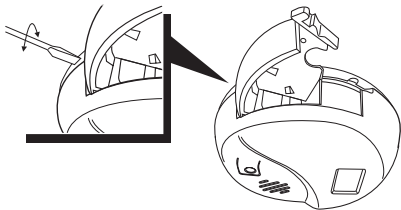

### TO PERMANENTLY REMOVE THE BRACKET LOCK:

Insert the flathead screwdriver between the locking pin and the lock, and pry the pin out of the lock.

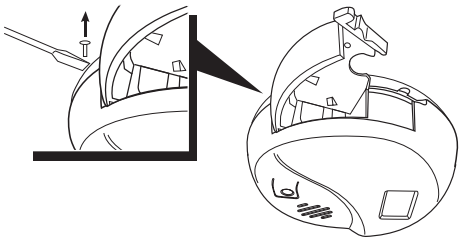

## HOW TO INSTALL YOUR CO ALARM

This unit is designed to be mounted on any standard wiring junction box up to a 4-inch diagonal size, on either the ceiling or wall. Read "Where to Install CO Alarms" and "Where Not To Install CO Alarms" before you begin installation. If a junction box is not already in place, install one using standard #12 or #14 gauge copper wire.

### ⚠WARNING!

**This Alarm must have AC or battery power to operate. If the AC power fails, the battery back-up will power the Alarm for a short time if the 9V battery is fresh and correctly installed. If AC power fails, and the battery is dead or missing, the Alarm cannot operate.**

### BEFORE YOU BEGIN INSTALLATION

Find the pair of self-adhesive labels included with this CO Alarm.

- On each label write in the phone number of your emergency responder (like 911) and a qualified appliance technician.
- Place one label near the CO Alarm, and the other label in the "fresh air" location you plan to go if the alarm sounds.

**NOTE:** A qualified appliance technician is defined as "a person, firm, corporation, or company that either in person or through a representative, is engaged in and responsible for the installation, testing, servicing, or replacement of heating, ventilation, air conditioning (HVAC) equipment, combustion appliances and equipment, and/or gas fireplaces or other decorative combustion equipment."

## THE PARTS OF THIS CO ALARM

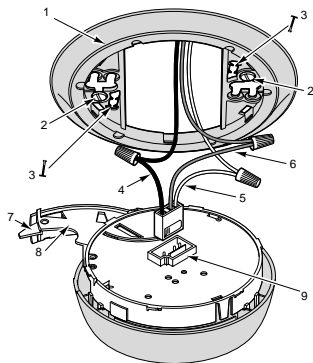

1	Mounting Bracket
2	Mounting Slot and Screw
3	Locking Pins (break out of bracket)
4	Hot (Black) AC Wire
5	Neutral (White) AC Wire
6	Interconnect Wire (Violet)
7	Lever to Open Battery Compartment
8	Swing-Out Battery Compartment
9	Quick-Connect Power

## SINGLE-STATION INSTALLATION

Tools needed: Standard/Flathead screwdriver.

### ⚠ DANGER!

**ELECTRICAL SHOCK HAZARD.** Turn off power to the area where you will install this unit at the circuit breaker or fuse box before beginning installation. Failure to turn off the power before installation may result in serious electrical shock, injury or death.

### CEILING MOUNTING:

1. Remove the mounting bracket from the base. Position the screw slots on the mounting bracket over the screws in the junction box. Tighten the screws.
2. Using wire nuts, connect the power connector to the AC power.
  - Connect the white wire on the power connector to the neutral wire in the junction box.
  - Connect the black wire on the power connector to the hot wire in the junction box.
  - Tuck the violet wire inside the junction box. **It is used for interconnect only.**
3. Plug the power connector into back of the unit.
4. Position the base of the Alarm over the mounting bracket and turn. The Alarm can be positioned over the bracket every 60°. Turn the unit clockwise (right) until the unit is in place.
5. Make sure CO Alarm is secured to mounting bracket.
6. If you are only installing one unit, restore power to the junction box.



## **⚠ DANGER!**

**ELECTRICAL SHOCK HAZARD. Do not restore power until the CO Alarm is completely installed. Restoring power before installation is complete may result in serious electrical shock, injury or death.**

7. Make sure the unit is receiving AC power. Under normal operation, the red indicator light will shine continuously. Display shows a dash under "READY".
8. If the red power indicator light does not light, **TURN OFF POWER TO THE JUNCTION BOX** and recheck all connections. If all connections are correct and the red power indicator still does not light when you restore the power, the unit should be replaced immediately.

### **WALL MOUNTING:**

1. Position the junction box face plate so screw holes are positioned as shown at right.
2. Remove mounting bracket from the base. Position the screw slots on the mounting bracket over the screws in the junction box. Tighten the screws.
3. Using wire nuts, connect the power connector to the AC power.
  - Connect the white wire on the power connector to the neutral wire in the junction box.
  - Connect the black wire on the power connector to the hot wire in the junction box.
  - Tuck the violet wire inside the junction box. **It is used for interconnect only.**
4. Plug the power connector into back of the unit.

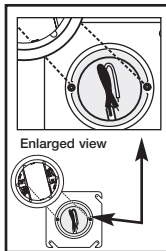

5. Position the base of the Alarm over the mounting bracket so display is rotated approximately 30° left of center. Turn the unit clockwise (right) until display is horizontal and the unit is in place.
6. Make sure CO Alarm is secured to mounting bracket.
7. If you are only installing one unit, restore power to the junction box.

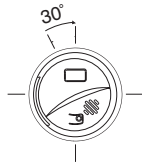

## **⚠ DANGER!**

**ELECTRICAL SHOCK HAZARD. Do not restore power until the CO Alarm is completely installed. Restoring power before installation is complete may result in serious electrical shock, injury or death.**

8. Make sure the unit is receiving AC power. Under normal operation, the red indicator light will shine continuously. Display shows a dash under "READY".
9. If the red power indicator light does not light, **TURN OFF POWER TO THE JUNCTION BOX** and recheck all connections. If all connections are correct and the red power indicator still does not light when you restore the power, the unit should be replaced immediately.

### **ACTIVATING THE BATTERY BACK-UP**

#### **IMPORTANT!**

Activate the battery back-up by removing the "Pull to Activate Battery Back-Up" tab. You do not need to open the battery compartment and reposition the battery during installation. **DO NOT remove the battery activation tab until AC power is turned on to conserve battery power. Test the alarm.** Press and hold the test button on the cover until the alarm sounds: 4 beeps, pause, 4 beeps, pause.

## INTERCONNECTING MULTIPLE CO ALARMS

### Interconnecting Multiple CO Alarms

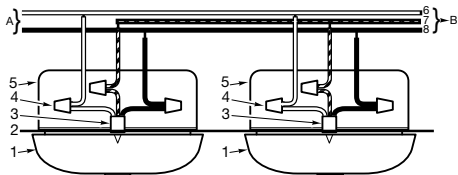

A	Unswitched 120VAC 60 Hz source
B	To Additional Model CO5120B or CO5120PDB CO Alarms, Maximum = 18 alarms
1	Carbon Monoxide Alarm
2	Ceiling or wall
3	Power connector
4	Wire nut
5	Junction box
6	Neutral (White) AC wire
7	Interconnect wire (Violet)
8	Hot (Black) AC wire

Interconnected units can provide earlier warning of a CO problem than stand-alone units, especially if the problem starts in a remote area of the dwelling. If any unit in the series senses CO, all units will alarm. To determine which CO Alarm initiated an alarm, refer to the table.

On Initiating Alarm	Red LED Flashes Once per Second
On All Other Alarms	Red LED Shines Continuously

All wiring must conform to all local electrical codes and Article 760 of the National Electrical Code. Refer to NFPA, Chapter 2 and/or your local building code for further connection requirements.

### ⚠WARNING!

**AC and AC/DC CO Alarms can be interconnected. Under AC power, all units will alarm when one senses CO. When power is interrupted, only the AC/DC units in the series will continue to send and receive signals. AC powered CO Alarms will not operate.**

### IMPORTANT!

Interconnect units within a single family residence only. Otherwise all households will experience unwanted alarms when you test any unit in the series. Interconnected units will only work if they are wired to compatible units and all requirements are met. It is recommended only **BRK Electronics®** carbon monoxide alarms CO5120B, and CO5120PDB be interconnected.



**Interconnected units must meet ALL of the following requirements:**

- A maximum of 18 units total may be interconnected. (See page 14 for details.)
- The same fuse or circuit breaker must power all interconnected units.
- The total length of wire interconnecting the units should be less than 1000 feet. The interconnect wire should be Type 18 gauge AWM or larger, rated at least 300V.
- If an interconnect wire is not already part of your household wiring, you will need to install one.

**Failure to meet any of the above requirements could damage the units and cause them to malfunction, removing your protection.**

## **MULTIPLE-STATION INSTALLATION**

### **⚠ DANGER!**

**ELECTRICAL SHOCK HAZARD.** Turn off power to the area where you will install this unit at the circuit breaker or fuse box before beginning installation. Failure to turn off the power before installation may result in serious electrical shock, injury or death.

### **CEILING MOUNTING:**

1. Remove the mounting bracket from the base. Position the screw slots on the mounting bracket over the screws in the junction box. Tighten the screws.
2. Strip off about 1/2" of the plastic coating on the violet interconnect wire on the power connector.

3. Using wire nuts, connect the power connector to the AC power.

- Connect the white wire on the power connector to the neutral wire (usually white) in the junction box.



- Connect the black wire on the power connector to the hot wire (usually black) in the junction box.



- Connect the violet wire on the power connector to the interconnect wire in the junction box. Repeat for each unit you are interconnecting. Never connect the hot or neutral wires in the junction box to the violet interconnect wire.



4. Plug the power connector into the back of the CO Alarm.
5. Position the base of the alarm over the mounting bracket and turn. The Alarm can be positioned over the bracket every 60°. Turn the unit clockwise (right) until the unit is in place.
6. Make sure CO Alarm is secured to the mounting bracket.

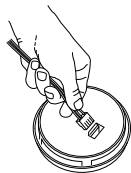

### **⚠ DANGER!**

**ELECTRICAL SHOCK HAZARD.** Do not restore power until all CO Alarms are completely installed. Restoring power before installation is complete may result in serious electrical shock, injury or death.

7. Make sure each unit is receiving AC power. Under normal operation, the red light (LED) will shine continuously. Display shows a dash under "READY".

- If the red power indicator light does not light, TURN OFF POWER TO THE JUNCTION BOX and recheck all connections. If all connections are correct and the red power indicator still does not light when you restore the power, the unit should be replaced immediately.
- Test each CO Alarm. Press and hold the test button until the unit alarms: 4 beeps, pause, 4 beeps, pause.

#### WALL MOUNTING:

- Position the junction box face plate so screw holes are positioned as shown at right.
- Remove mounting bracket from the base. Position the screw slots on the mounting bracket over the screws in the junction box. Tighten the screws.
- Strip off about 1/2" of the plastic coating on the violet interconnect wire on the power connector.
- Using wire nuts, connect the power connector to the AC power.
  - Connect the white wire on the power connector to the neutral wire (usually white) in the junction box.
  - Connect the black wire on the power connector to the hot wire (usually black) in the junction box.
  - Connect the violet wire on the power connector to the interconnect wire in the junction box. Repeat for each unit you are interconnecting. Never connect the hot or neutral wires in the junction box to the violet interconnect wire.

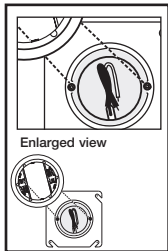

- Plug the power connector into the back of the CO Alarm.
- Position the base of the Alarm over the mounting bracket so display is rotated approximately 30° left of center. Turn the unit clockwise (right) until display is horizontal and the unit is in place.
- Make sure CO Alarm is secured to the mounting bracket.

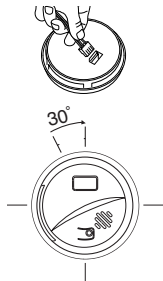

#### **⚠ DANGER!**

**ELECTRICAL SHOCK HAZARD. Do not restore power until the CO Alarm is completely installed. Restoring power before installation is complete may result in serious electrical shock, injury or death.**

- Make sure each unit is receiving AC power. Under normal operation, the red light (LED) will shine continuously. Display shows a dash under "READY".
- If the red power indicator light does not light, TURN OFF POWER TO THE JUNCTION BOX and recheck all connections. If all connections are correct and the red power indicator still does not light when you restore the power, the unit should be replaced immediately.
- Test each CO Alarm. Press and hold the test button until the unit alarms: 4 beeps, pause, 4 beeps, pause.

## IMPORTANT!

In a series of interconnected Alarms, you must test each Alarm separately by pressing and holding the test button. Make sure all units alarm when each one is tested.

## IMPORTANT!

If any unit in the series does not alarm during testing, TURN OFF POWER and recheck connections. If it does not alarm when you restore power, replace it immediately.

# CHAPTER 3: IF YOUR CO ALARM SOUNDS

## ⚠WARNING!

Actuation of your CO Alarm indicates the presence of carbon monoxide (CO) which can kill you. When your CO Alarm sounds, you must not ignore it!

## IF THE ALARM SOUNDS:

1. Operate the Test/Silence button to silence the alarm.
2. Call your emergency services, fire department or 911. Write down the number of your local emergency service here:  

---
3. Immediately move (everyone) to fresh air—outdoors or by an open door or window. Do a head count to check that all persons are accounted for. Do not re-enter the premises, or move away from the open door or window until the emergency services responder has arrived, the premises have been aired out, and your CO Alarm remains in its normal condition.

## ACTIVATING THE BATTERY BACK-UP

## IMPORTANT!

Activate the battery back-up by removing the “Pull to Activate Battery Back-Up” tab. You do not need to open the battery compartment and reposition the battery during installation.



**DO NOT remove the battery activation tab until AC power is turned on to conserve battery power.**

**Test the alarm.** Press and hold the test button on the cover until the alarm sounds:  
4 beeps, pause, 4 beeps, pause.

**(Do not remove or disconnect the alarm!)**

4. After following steps 1-3, if your CO Alarm reactivates within a 24-hour period, repeat steps 1-3 and call a qualified appliance technician to investigate for sources of CO from fuel-burning equipment and appliances, and inspect for proper operation of this equipment. If problems are identified during this inspection have the equipment serviced immediately. Note any combustion equipment not inspected by the technician, and consult the manufacturers' instructions, or contact the manufacturers directly, for more information about CO safety and this equipment. Make sure that motor vehicles are not, and have not, been operating in an attached garage or adjacent to the residence. Write down the number of a qualified appliance technician here:  

---

Display Shows...	It Means...
30 (or higher)	Developing CO problem. Display will only show levels of carbon monoxide 30 ppm or higher.
70 (or higher)	The unit is calibrated to sound an alarm before 240 minutes have passed when exposed to this level.
150 (or higher)	The unit is calibrated to sound an alarm before 50 minutes have passed when exposed to this level. At this level, an average healthy adult may feel a headache within 90 minutes.
400 (or higher)	The unit is calibrated to sound an alarm before 15 minutes have passed when exposed to this level. This level may be life threatening to a normal healthy adult within three hours.
A number higher than 450	Over 450 ppm has been detected. Evacuate immediately!

## USING THE SILENCE FEATURE

### ⚠ WARNING!

**NEVER disconnect the power to your CO Alarm to silence the horn—use the silence feature. Disconnecting the CO Alarm removes your protection! See previous page for details on responding to an alarm.**

The Silence feature is intended to temporarily silence your CO Alarm's alarm horn while you correct the problem—it will not correct a CO problem. While the alarm is silenced, it will continue to monitor the air for CO. When CO reaches the "Alarm" level, it will sound—repeating horn pattern: 4 beeps, a pause, 4 beeps, etc. Press and hold the Test/Silence button until the horn is silent. The Silence cycle will last approximately 4 minutes.

**To silence an interconnected series of Alarms, you must press the Test/Silence button on the initiating alarm (the unit with the flashing red light). If you press the Test/Silence on any other Alarm, it will only silence that unit, not the whole interconnected series.**

**NOTE:** After the 4-minute silence cycle, the CO Alarm re-evaluates present CO levels and responds accordingly. If CO levels remain potentially dangerous—or start rising higher—the horn will start sounding again.

### While the CO Alarm is silenced:

**If the CO Alarm...is silent for only 4 minutes, then starts sounding loudly—4 beeps, then a pause, 4 beeps, then a pause. Red light (LED) continues flashing...**

**This means...CO levels are still potentially dangerous.**

**If the CO Alarm...remains silent...**

**This means...unit has returned to normal operation.**

## FINDING THE SOURCE OF CO AFTER AN ALARM

Because CO may dissipate by the time an investigator arrives, it may be difficult to locate the source of CO. See Chapter 5 "What You Need to Know About CO." **BRK Brands, Inc. shall not be obligated to pay for any carbon monoxide investigation or service call.**

### THE "LATCHING ALARM" INDICATOR:

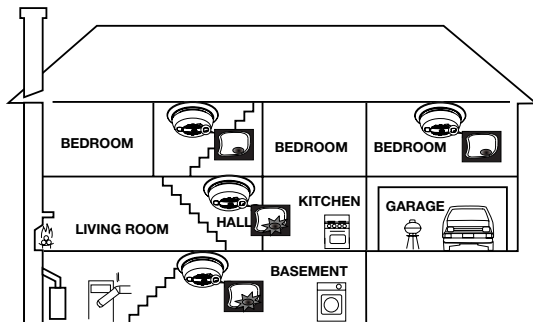

#### KEY:

 **LATCHING ALARM:**  
Unit was exposed  
to alarm levels of CO

 **LATCHING NOT ACTIVATED:**  
Unit was not exposed  
to alarm levels of CO

The **Latching Alarm Indicator** is activated after a CO Alarm is exposed to alarm levels of carbon monoxide. After CO levels drop below alarm levels, the red LED will begin to flash once every 5 seconds. It will continue to flash or "latch" until you clear it by pressing the test button.

This feature helps emergency responders, investigators, or service technicians identify which unit(s) in your home were exposed to alarm levels of carbon monoxide. This can help investigators pinpoint the source of CO.

#### Interconnected Alarms

Latching Alarm Indicator shows which Alarm(s) in the series were exposed to alarm levels of carbon monoxide.

The Latching Alarm Indicator stays ON until you clear it, so it can alert you to a CO Alarm that occurred while you were away from home, even though CO present in the air has dropped below alarm levels.

## CHAPTER 4: TESTING AND MAINTENANCE

### WEEKLY TESTING

---

Push and hold the Test/Silence button until a loud alarm sounds— 4 beeps, pause, 4 beeps. This sequence should last for 10 seconds. If the Alarm ever fails to test properly, replace it immediately. If the Alarm is not working properly, refer to “Limited Warranty”.

#### ▲WARNING!

- **Test/Silence button is the only proper way to test the CO Alarm. NEVER use vehicle exhaust! Exhaust may cause permanent damage and voids your warranty.**
- **DO NOT stand close to the Alarm when the horn is sounding. Exposure at close range may be harmful to your hearing. When testing, step away when horn starts sounding.**

### REGULAR MAINTENANCE

---

To keep the CO Alarm in good working order:

- Test it every week using the Test/Silence button.
- Vacuum the CO Alarm cover at least twice a year, using the soft brush attachment. Test the alarm again after vacuuming.

#### IMPORTANT!

Household cleaners, aerosol chemicals and other contaminants can affect sensor. When using any of these materials near Alarm, make sure room is well ventilated.

#### ▲CAUTION!

**DO NOT spray cleaning chemicals or insect sprays directly on or near the Alarm. DO NOT paint over the Alarm, this may permanently damage the Alarm. DO NOT expose the Alarm to strong fumes such as painting or fumigating.**

### THE LOW (OR MISSING) BATTERY WARNING:



The horn will “chirp” once a minute and the word “bat” will flash on and off on the display.

**NOTE:** You should replace the battery immediately to continue your protection.

**LOW BATTERY SILENCE FEATURE.** If AC power is on, press the Test/Silence button to silence the low battery “chirp” for up to 8 hours. The alarm will continue to operate as long as AC power is supplied. However, **replace the battery as soon as possible**, to maintain protection in event of a power outage.

**Choosing a replacement battery:** This unit requires one standard 9V alkaline battery. The following alkaline batteries are acceptable as replacements. This list supplements the list on the carbon monoxide alarm battery door: Eveready #522 (Energizer); Duracell #MN1604, MX1604 (Ultra). You may also use a Lithium battery like an Ultralife U9VL-J for longer service between battery changes. These batteries are available at many local retail stores. Replacement batteries are commonly available at local retail stores.

#### IMPORTANT!

Use only the alkaline or lithium replacement batteries listed. The unit may not operate properly with other batteries. Never use rechargeable batteries since they may not provide a constant charge.

#### ▲WARNING!

**Disconnect AC power before changing battery. Shock hazard exists if AC power is miswired.**

## CHAPTER 5: WHAT YOU NEED TO KNOW ABOUT CO

### WHAT IS CO?

CO is an invisible, odorless, tasteless gas produced when fossil fuels do not burn completely, or are exposed to heat (usually fire). Electrical appliances typically do not produce CO.

#### **These fuels include:**

Wood, coal, charcoal, oil, natural gas, gasoline, kerosene, and propane.

Common appliances are often sources of CO. If they are not properly maintained, are improperly ventilated, or malfunction, CO levels can rise quickly. CO is a real danger now that homes are more energy efficient. "Air-tight" homes with added insulation, sealed windows, and other weatherproofing can "trap" CO inside.

### SYMPTOMS OF CO POISONING

These symptoms are related to CO POISONING and should be discussed with ALL household members.

#### **Mild Exposure:**

Slight headache, nausea, vomiting, fatigue ("flu-like" symptoms).

#### **Medium Exposure:**

Throbbing headache, drowsiness, confusion, fast heart rate.

#### **Extreme Exposure:**

Convulsions, unconsciousness, heart and lung failure. Exposure to Carbon Monoxide can cause brain damage, death.

### **▲CAUTION!**

Some individuals are more sensitive to CO than others, including people with cardiac or respiratory problems, infants, unborn babies, pregnant mothers, or elderly people can be more quickly and severely affected by CO. Members of sensitive populations should consult their doctors for advice on taking additional precautions.

### FINDING THE SOURCE OF CO AFTER AN ALARM

---

Carbon monoxide is an odorless, invisible gas, which often makes it difficult to locate the source of CO after an alarm. These are a few of the factors that can make it difficult to locate sources of CO:

- House well ventilated before the investigator arrives.
- Problem caused by "backdrafting."
- Transient CO problem caused by special circumstances.

**BRK Brands, Inc. shall not be obligated to pay for any carbon monoxide investigation or service call.**

## POTENTIAL SOURCES OF CO IN THE HOME

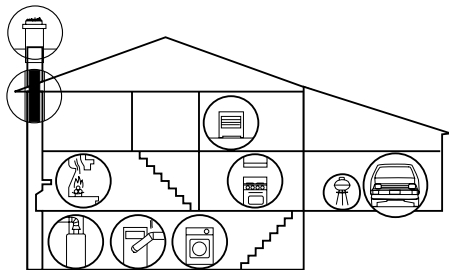

**Fuel-burning appliances like:** portable heater, gas or wood burning fireplace, gas kitchen range or cooktop, gas clothes dryer.

**Damaged or insufficient venting:** corroded or disconnected water heater vent pipe, leaking chimney pipe or flue, or cracked heat exchanger, blocked or clogged chimney opening.

**Improper use of appliance/device:** operating a barbecue grill or vehicle in an enclosed area (like a garage or screened porch).

**Transient CO Problems:** “transient” or on-again-off-again CO problems can be caused by outdoor conditions and other special circumstances.

**The following conditions can result in transient CO situations:**

1. Excessive spillage or reverse venting of fuel appliances caused by outdoor conditions such as:
  - Wind direction and/or velocity, including high, gusty winds. Heavy air in the vent pipes (cold/humid air with extended periods between cycles).
  - Negative pressure differential resulting from the use of exhaust fans.
  - Several appliances running at the same time competing for limited fresh air.
  - Vent pipe connections vibrating loose from clothes dryers, furnaces, or water heaters.
  - Obstructions in or unconventional vent pipe designs which can amplify the above situations.
2. Extended operation of unvented fuel burning devices (range, oven, fireplace).
3. Temperature inversions, which can trap exhaust close to the ground.
4. Car idling in an open or closed attached garage, or near a home.

These conditions are dangerous because they can trap exhaust in your home. Since these conditions can come and go, they are also hard to recreate during a CO investigation.



## **HOW CAN I PROTECT MY FAMILY?**

A CO Alarm is an excellent means of protection. It monitors the air and sounds a loud alarm before carbon monoxide levels become threatening for average, healthy adults.

### **A CO Alarm is not a substitute for proper maintenance of home appliances.**

To help prevent CO problems and reduce the risk of CO poisoning:

- Clean chimneys and flues yearly. Keep them free of debris, leaves, and nests for proper air flow. Also, have a professional check for rust and corrosion, cracks, or separations. These conditions can prevent proper air movement and cause backdrafting. Never “cap” or cover a chimney in any way that would block air flow.
- Test and maintain all fuel-burning equipment annually. Many local gas or oil companies and HVAC companies offer appliance inspections for a nominal fee.
- Make regular visual inspections of all fuel-burning appliances. Check appliances for excessive rust and scaling. Also check the flame on the burner and pilot lights. The flame should be blue. A yellow flame means fuel is not being burned completely and CO may be present. Keep the blower door on the furnace closed. Use vents or fans when they are available on all fuel-burning appliances. Make sure appliances are vented to the outside. Do not use portable/outdoor grills or barbecue indoors, or in garages or on screen porches.

- Check for exhaust backflow from CO sources. Check the draft hood on an operating furnace for a backdraft. Look for cracks on furnace heat exchangers.
- Check the house or garage on the other side of shared wall.
- Keep windows and doors open slightly. If you suspect that CO is escaping into your home, open a window or a door. Opening windows and doors can significantly decrease CO levels.

**In addition, familiarize yourself with the enclosed checklist, read this manual in its entirety, and make sure you understand what to do if your CO Alarm sounds.**

## CHAPTER 6: UNDERWRITERS LABORATORIES INC. UL2034

### WHAT LEVELS OF CO CAUSE AN ALARM?

Underwriters Laboratories Inc. UL2034 defines 3 specific alarm points by which all residential CO Alarms must alarm. They are measured in parts per million (ppm) of CO over time (in minutes).

#### **UL2034 Required Alarm Points:**

- If the Alarm is exposed to 400 ppm of CO, IT MUST ALARM BETWEEN 4 and 15 MINUTES
- If the Alarm is exposed to 150 ppm of CO, IT MUST ALARM BETWEEN 10 and 50 MINUTES.
- If the Alarm is exposed to 70 ppm of CO, IT MUST ALARM BETWEEN 60 and 240 MINUTES.

### **IMPORTANT!**

CO Alarms are designed to alarm before there is an immediate life threat. Since you cannot see or smell CO, never assume it's not present.

- An exposure to 100 ppm of CO for 20 minutes may not affect average, healthy adults, but after 4 hours the same level may cause headaches.
- An exposure to 400 ppm of CO may cause headaches in average, healthy adults after 35 minutes, but can cause death after 2 hours.

### **IMPORTANT!**

This CO Alarm measures exposure to CO over time. It alarms if CO levels are extremely high in a short period of time, or if CO levels reach a certain minimum over a long period of time. The CO Alarm generally sounds an alarm before the onset of symptoms in average, healthy adults.

Why is this important? Because you need to be warned of a potential CO problem while you can still react in time. In many reported cases of CO exposure, victims may be aware that they are not feeling well, but become disoriented and can no longer react well enough to exit the building or get help. Also, young children and pets may be the first affected. The average healthy adult might not feel any symptoms when the CO Alarm sounds. However, people with cardiac or respiratory problems, infants, unborn babies, pregnant mothers, or elderly people can be more quickly and severely affected by CO. If you experience even mild symptoms of CO poisoning, consult your doctor immediately!

### **⚠WARNING!**

**This product is intended for use in ordinary indoor locations of family living units. It is not designed to measure CO levels in compliance with Occupational Safety and Health Administration (OSHA) commercial or industrial standards.**

## CHAPTER 7: TROUBLESHOOTING GUIDE

### **⚠DANGER!**

**ELECTRICAL SHOCK HAZARD.** Turn off the power to the area where the CO Alarm is installed **BEFORE** removing it from the mounting bracket or checking any electrical connections! Failure to turn off the power first may result in serious electrical shock, injury or death.

The following guide can help you identify a potential problem with the installation or operation of your CO Alarm. It is not meant to be an all-inclusive list of all CO Alarm conditions. If you are experiencing a condition not covered in the next several pages, please contact Consumer Affairs.

<b>If your CO Alarm does this...</b>	<b>This means...</b>	<b>You should...</b>
Red light is OFF. Unit will not alarm when you press the Test/Silence button.	Unit may not be receiving any power.	Check the AC power supply. Make sure the power connector is securely attached to the Alarm. Make sure a fresh 9V battery is installed to power the battery back-up.
Red light flashes once a minute (horn is silent). Display shows "bat".	Alarm is not receiving AC power.	Unit is operating on DC battery back-up. Check the AC power supply.
Once a minute, the red light flashes and the horn "chirps" and flashing "bat" displays continuously.	Low battery warning.	Replace the 9V battery in the battery back-up. Disconnect AC power before changing the battery.
Once a minute, the alarm sounds 3 quick "chirps", and the red light flashes quickly three times and display reads "Err".	Based on its Self Test diagnostics, the unit has detected a malfunction. The unit needs to be replaced.	Units under warranty should be returned to manufacturer for replacement. See "Limited Warranty" for details.
CO Alarm goes back into alarm 4 minutes after you press the Test/Silence button.	CO levels are still potentially dangerous.	Refer to Chapter 3 "If Your CO Alarm Sounds" for details on how to respond to an alarm. If anyone is feeling ill, EVACU-ATE your home immediately and call 911.
CO Alarm sounds frequently even though no high levels of CO are revealed in an investigation.	The CO Alarm may be improperly located. Refer to "Where to Install Your CO Alarm."	Relocate your Alarm. If frequent alarms continue, have home rechecked for potential CO problems. You may be experiencing an intermittent CO problem.

If you have any questions that cannot be answered by reading this manual, call Consumer Affairs:1-800-323-9005.

Download from [www.Somanuals.com](http://www.Somanuals.com), All Manuals Search And Download.

## CHAPTER 8: GENERAL LIMITATIONS OF CO ALARMS

This CO Alarm is intended for residential use. It is not intended for use in industrial applications where Occupational Safety and Health Administration (OSHA) requirements for carbon monoxide detectors must be met.

**CO Alarms will not work without power.** This CO Alarm requires a continuous supply of AC power, and a fresh, correctly installed 9V battery to power the battery back-up.

**This CO Alarm will not sense carbon monoxide that does not reach the sensor.** This CO Alarm will only sense CO at the sensor. CO may be present in other areas. Doors or other obstructions may affect the rate at which CO reaches the CO Alarm. For this reason, if bedroom doors are usually closed at night, we recommend you install a CO Alarm in each bedroom and in the hallway between them.

**CO Alarms may not sense CO on another level of the home.** For example, a CO Alarm on the second level, near the bedrooms, may not sense CO in the basement. For this reason, one CO Alarm may not give adequate warning. Complete coverage is recommended. Place CO Alarms on each level of the home.

**CO Alarms may not be heard.** The Alarm horn loudness meets or exceeds current UL standards of 85 dB at 10 feet. However, if the CO Alarm is installed outside the bedroom, it may not wake up a sound sleeper or one who has recently used drugs or has been drinking alcoholic beverages. This is especially true if the door is closed or only partly open. Even persons who are awake may not hear the alarm horn if the sound is blocked by distance or closed doors. Noise from traffic, stereo, radio, television, air conditioner, or other appliances may also prevent alert persons from hearing the alarm horn. This CO Alarm is not intended for people who are hearing impaired.

**CO Alarms are not a substitute for a smoke alarm.** Although fire is a source of carbon monoxide, this CO Alarm does not sense smoke or fire. This CO Alarm senses CO that may be escaping unnoticed from malfunctioning furnaces, appliances, or other sources. Early warning of fire requires the installation of smoke alarms.

**CO Alarms are not a substitute for life insurance.** Though these CO Alarms warn against increasing CO levels, BRK Brands, Inc. does not warrant or imply in any way that they will protect lives from CO poisoning. Homeowners and renters must still insure their lives.

**CO Alarms have a limited life.** Although the CO Alarm and all of its parts have passed many stringent tests and are designed to be as reliable as possible, any of these parts could fail at any time. Therefore, you must test your CO Alarm weekly.

**CO Alarms are not foolproof.** Like all other electronic devices, CO Alarms have limitations. They can only detect CO that reaches their sensors. They may not give early warning to rising CO levels if the CO is coming from a remote part of the home, away from the CO Alarm.



## LIMITED WARRANTY

**Coverage:** BRK Brands, Inc. ("BRK") the maker of BRK Electronics® brand products, warrants that for a period of 5 years from the date of purchase, this product will be free from defects in material and workmanship. BRK, at its option, will repair or replace this product or any component of the product found to be defective during the warranty period. Replacement will be made with a new or remanufactured product or component. If the product is no longer available, replacement may be made with a similar product of equal or greater value. This is your exclusive warranty.



This warranty is valid for the original retail purchaser from the date of initial retail purchase and is not transferable. Keep the original sales receipt. Proof of purchase is required to obtain warranty performance. BRK dealers, service centers, or retail stores selling BRK products do not have the right to alter, modify or any way change the terms and conditions of this warranty.

This warranty does not cover normal wear of parts or damage resulting from any of the following: negligent use or misuse of the product, use on improper voltage or current, use contrary to the operating instructions, disassembly, repair or alteration by anyone other than BRK or an authorized service center. Further, the warranty does not cover acts of God, such as fire, flood, hurricanes and tornadoes or any batteries that are included with this unit.

BRK shall not be liable for any incidental or consequential damages caused by the breach of any express or implied warranty. Except to the extent pro-

hibited by applicable law, any implied warranty of merchantability or fitness for a particular purpose is limited in duration for to the duration of the above warranty. Some states, provinces, or jurisdictions do not allow the exclusion or limitation of incidental or consequential damages or limitations on how long an implied warranty lasts, so the above limitations or exclusion may not apply to you. This warranty gives you specific legal rights, and you may also have other rights that vary from state to state, or province to province.

### How to Obtain Warranty Service:

**Service:** If service is required, do not return the product to your retailer. In order to obtain warranty service, contact the Consumer Affairs Division at 1-800-323-9005, 7:30 AM to 5:00 PM, Central Standard Time, Monday through Friday. To assist in serving you, please have the model number and date of purchase available when calling.  
3920 Enterprise Court, Aurora, IL 60504-8132.

**Battery:** BRK Brands, Inc. make no warranty, express or implied, written or oral, including that of merchantability or fitness for any particular purpose with respect to battery.

Please record Date and Where Purchased:

\_\_\_\_\_

BRK Electronics® is a registered trademark  
of BRK Brands, Inc.

M06-1060-000 08/01

## Free Manuals Download Website

<http://myh66.com>

<http://usermanuals.us>

<http://www.somanuals.com>

<http://www.4manuals.cc>

<http://www.manual-lib.com>

<http://www.404manual.com>

<http://www.luxmanual.com>

<http://aubethermostatmanual.com>

Golf course search by state

<http://golfingnear.com>

Email search by domain

<http://emailbydomain.com>

Auto manuals search

<http://auto.somanuals.com>

TV manuals search

<http://tv.somanuals.com>