

Mx-1000 Series

1 List Of Contents

1	List Of Contents.....	2
2	List Of Figures.....	3
3	List of Tables.....	3
4	Introduction.....	4
5	Overview of Installation and Commissioning.....	4
6	Internal Panel Views.....	5
7	Mx-1016 16 -Zone – Typical Wiring Schematic.....	8
8	Circuit Connection Details.....	9
8.1	2-16 Zone Motherboard Termination Details.....	9
8.2	16 Zone Expansion Board Termination Details.....	9
9	Mx-1000 Series C1627 Motherboard Features.....	10
10	Mx-1000 Series C1632 16-Zone Expansion Board Features.....	11
11	Power Supplies.....	11
11.1	Visual indications.....	11
11.2	Battery Disconnect.....	12
11.3	32-Zone Power Supply Features And Connections.....	12
12	Installation.....	13
12.1	Electrical Safety.....	13
12.1.1	IMPORTANT NOTES ON BATTERIES:.....	13
12.1.2	ELECTRICAL SAFETY:.....	14
12.2	Installation Instructions.....	15
12.2.1	Mx-1000 Series Panel Installation Instructions.....	15
12.2.2	Installation And Connection Of The C1631 Repeater Interface.....	17
13	Commissioning.....	19
13.1	Introduction.....	19
13.2	Commissioning Checklist.....	19
13.3	An Overview Of The Commissioning Procedure.....	19
13.4	Pre-Commissioning Wiring Check.....	20
13.5	Powering up.....	21
13.6	Configuration.....	21
13.6.1	Basic Default Configuration.....	21
13.6.2	Site-Specific Configuration.....	21
13.7	Commissioning Procedure.....	21
13.7.1	Alarm Circuits.....	21
13.7.2	Commissioning zones.....	22
13.7.3	Commissioning the Class Change Input.....	23
13.7.4	Commissioning the Fire and Fault Routing Outputs.....	23
13.7.5	Commissioning the Fire Protection control signal.....	23
13.7.6	Commissioning ancillary inputs.....	24
13.7.7	Commissioning ancillary outputs.....	24
13.7.8	Commissioning repeaters.....	24
14	User Controls and Indications.....	25
14.1	User Indications [showing optional clock module].....	25
14.2	User Controls [showing optional clock module].....	26
15	Operating the Engineer's functions.....	27
15.1	Engineer's Zone/Output Configuration Process:.....	27
15.2	Zone or Output Configuration.....	27
15.3	To Restore the Factory Default Configuration for Zones & Outputs:.....	28
15.4	Engineer's Zone/Output Configuration Time-out Warning:.....	29
15.5	Invalid Configuration conditions:.....	29
15.6	List of configuration DIL switches and their functions.....	29
15.7	Configurable Options via DIL switch selection on Repeater Interface Board:.....	32
15.8	Configuring the Fire Routing, Fire Protection and Fault routing O/Ps.....	33
15.9	Enable/disable earth fault monitoring.....	33

34 Moorland Way : Nelson Park : Cramlington
Northumberland : NE23 1WE
Tel: +44 (0)1670 707 111
Fax: +44 (0)1670 707 222
www.Advel.co.uk Email: Sales@Advel.co.uk



ISO9001



British Fire Protection Systems Association



ISO9001

16	Optional Clock Module – Configuration and Setting.....	33
16.1	Standard Module Engineer Mode:.....	33
16.1.1	To Zero the Alarm Counter:.....	33
16.1.2	To Access the Engineers Clock Module Edit Functions:.....	33
16.2	Configuring the Clock Module.....	36
16.3	C1651 Clock Module PCB Features.....	37
16.4	Clock Module Error Messages.....	37
16.4.1	WP DIL Switch Error Message:.....	37
16.4.2	EEPROM Error Message:.....	37
16.4.3	ROM Checksum Error message:.....	38
17	Mechanical, Electrical & Environmental Specification.....	39

2 List Of Figures

Figure 1	– Mx-1002 / Mx-1004 Internal View.....	5
Figure 2	– Mx-1008 / Mx-1016 Internal View.....	5
Figure 3	– Mx-1032 Internal View.....	6
Figure 4	– 2/4 Zone Panel – General Assembly [with optional clock/time module].....	6
Figure 5	– 8/16 Zone Panel – General Assembly [with optional clock/time module].....	7
Figure 6	– 32 Zone Panel – General Assembly [with optional clock/time module].....	7
Figure 7	– Typical Wiring Diagram.....	8
Figure 8	– C1627 Field Termination.....	9
Figure 9	– C1632 16-Zone Expansion Board Field Termination.....	9
Figure 10	– C1627 Motherboard Layout.....	10
Figure 11	– C1632 16-Zone Expansion Board.....	11
Figure 12	– 32-Zone Power Supply Layout.....	12
Figure 13	– Repeater Connection Diagram.....	18
Figure 14	– C1651 Clock Module PCB.....	37

3 List of Tables

Table 1	- Delay Switch Settings.....	31
Table 2	- C1631 setting for quantity of repeaters.....	32
Table 3	- C1631 setting for repeater addresses.....	32
Table 4	– C1651 Clock Module DIL switch 1 and Link 1 Settings.....	36

4 Introduction

Thank you for purchasing the *Mx-1000* conventional control panel. The *Mx-1000* range of panels have been designed, manufactured and tested to meet the requirements of BSEN 54 Parts 2 & 4 and will provide the user with many years of reliable service.

This document contains all the information necessary for the installation, commissioning and maintenance of the *Mx-1000* range of panels and repeaters.

NOTE: It is important to read this manual fully before commencing installation.

The following supporting documentation is also available:

- *Mx-1000* Sales Literature
- *Mx-1000* Panel Application Guide (Doc. No. 680-077)
- *Mx-1000* User Manual (Doc. No. 680-072)
- Wiring Recommendations

5 Overview of Installation and Commissioning

This section lists the steps that are taken in designing, installing and commissioning a *Mx-1000* system.

1. **Install all field wiring and equipment**
 - Refer to the Installation Guidelines in section 12.2 below.
 - Refer to the field device installation manuals
2. Install the panel
 - Refer to the installation instructions in section 12.2 below.
 - Do not connect the field equipment at this stage.
3. Connect any repeaters (if applicable)
 - Refer to the installation instructions in section 12.2 below.
4. Commission the panel
 - Refer to Commissioning in section 13 below.

6 Internal Panel Views

Figure 1 – Mx-1002 / Mx-1004 Internal View

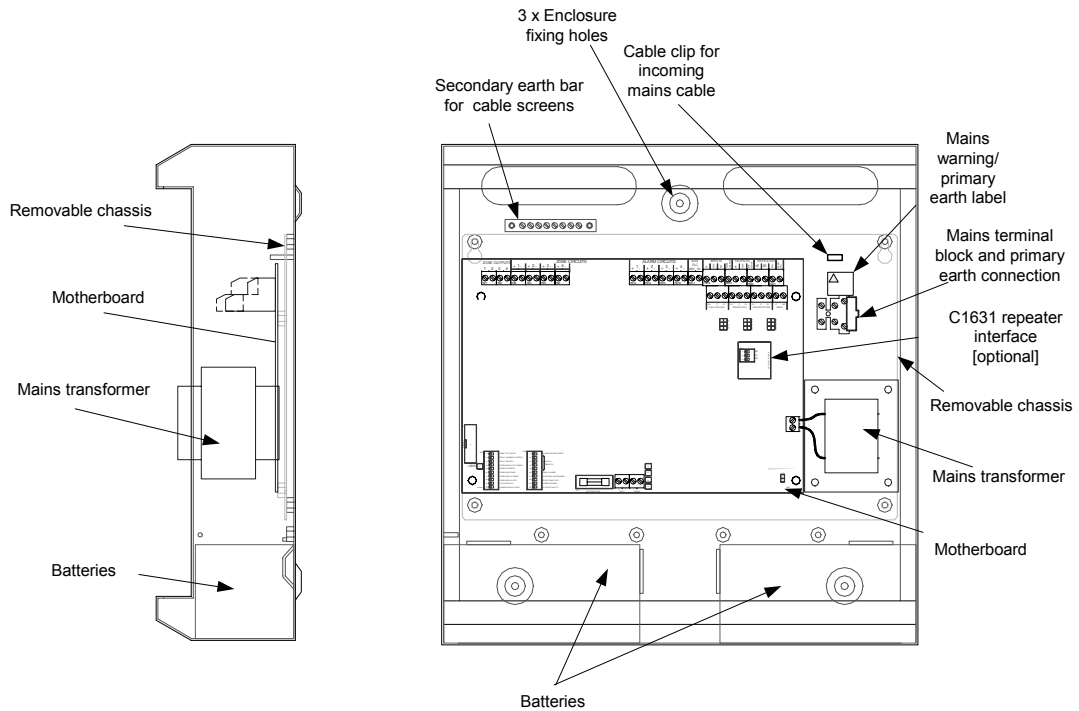

Figure 2 – Mx-1008 / Mx-1016 Internal View

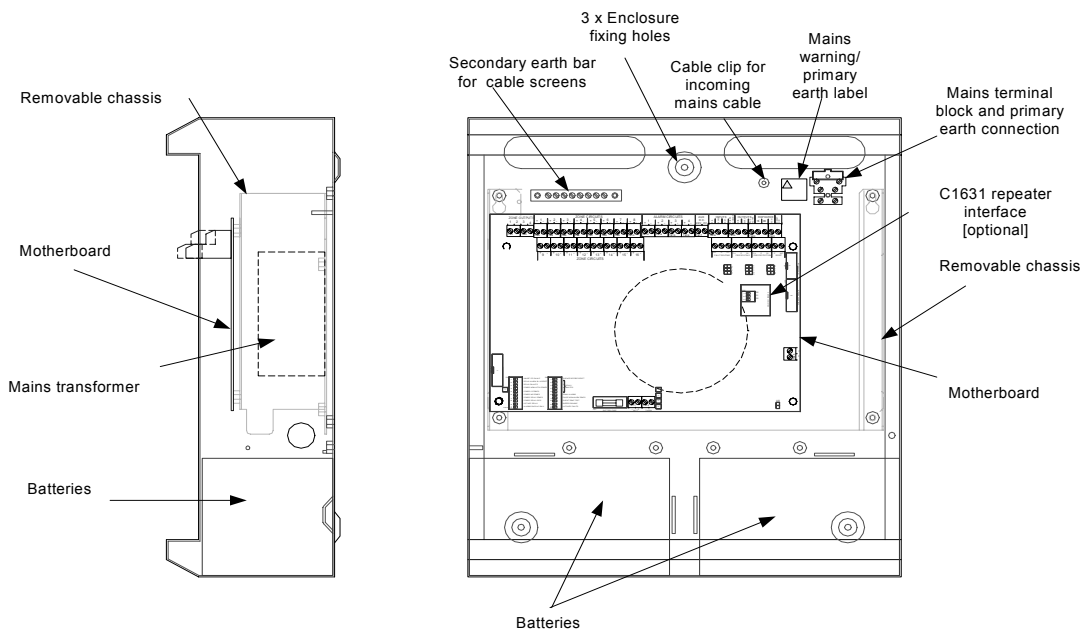

Figure 5 – 8/16 Zone Panel – General Assembly [with optional clock/time module]

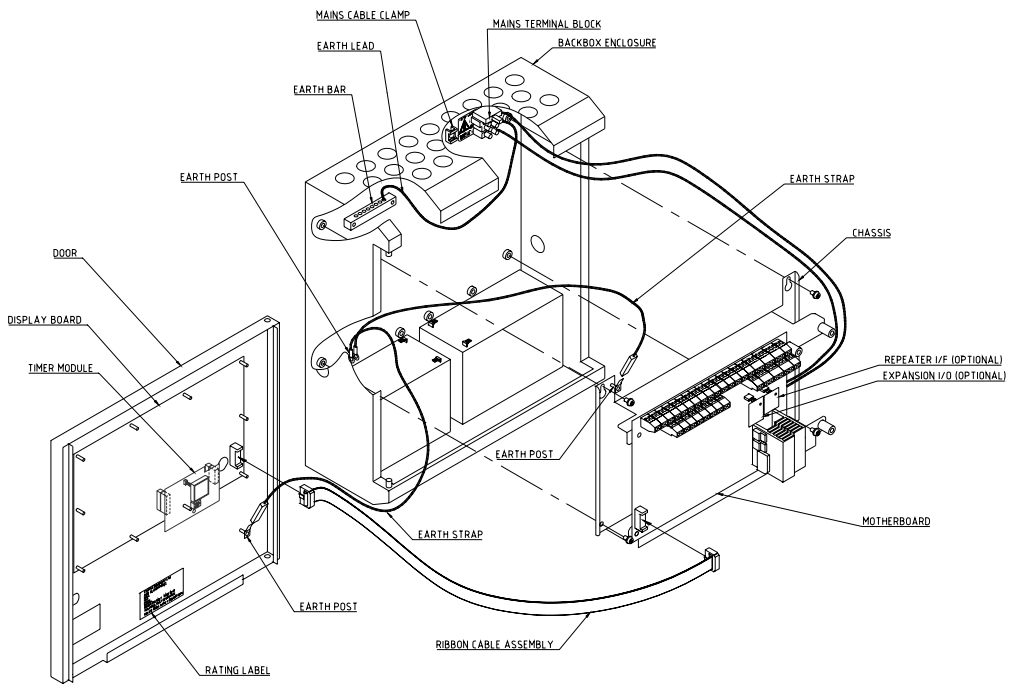
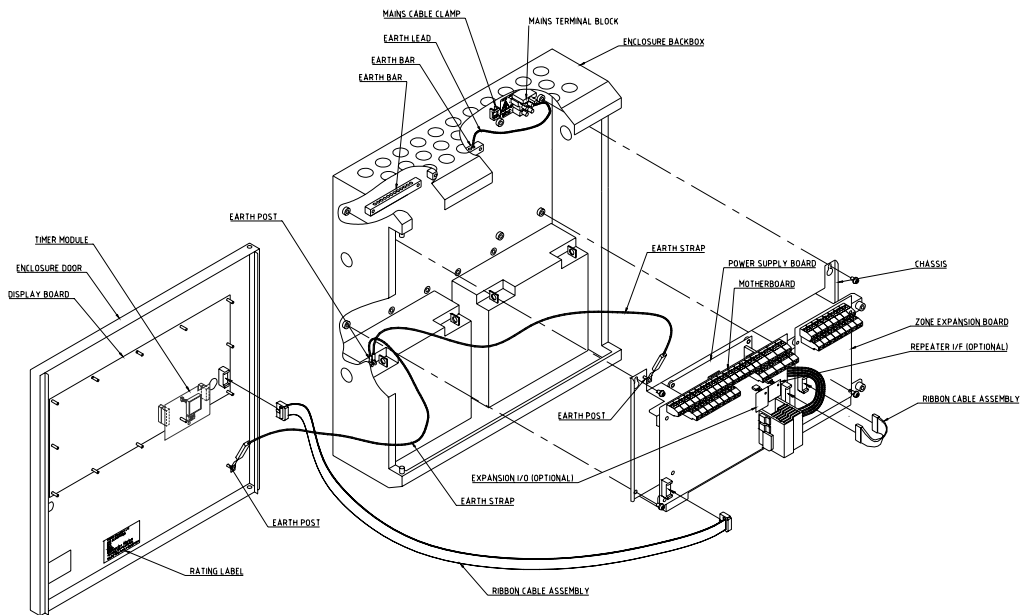
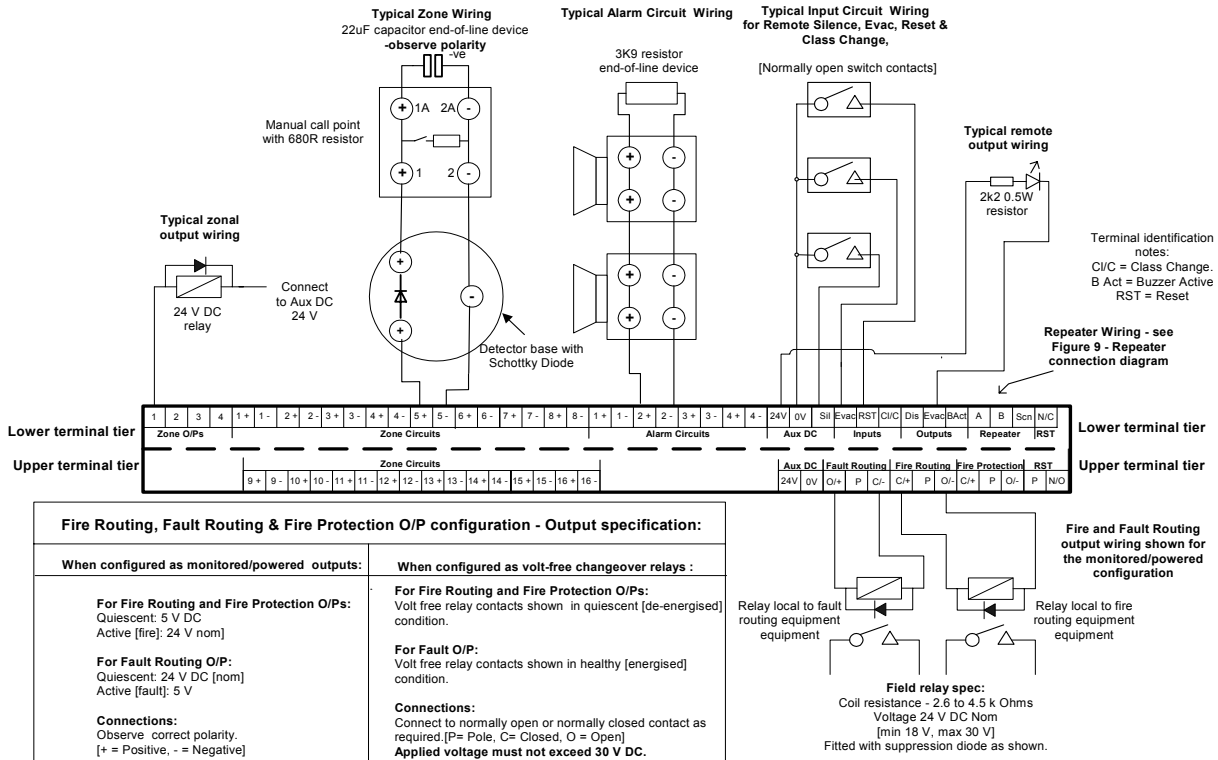

Figure 6 - 32 Zone Panel – General Assembly [with optional clock/time module]



7 Mx-1016 16 -Zone – Typical Wiring Schematic

Figure 7 – Typical Wiring Diagram



9 Mx-1000 Series C1627 Motherboard Features

Figure 10 illustrates the motherboard features referred to elsewhere in the documentation.

Figure 10 – C1627 Motherboard Layout

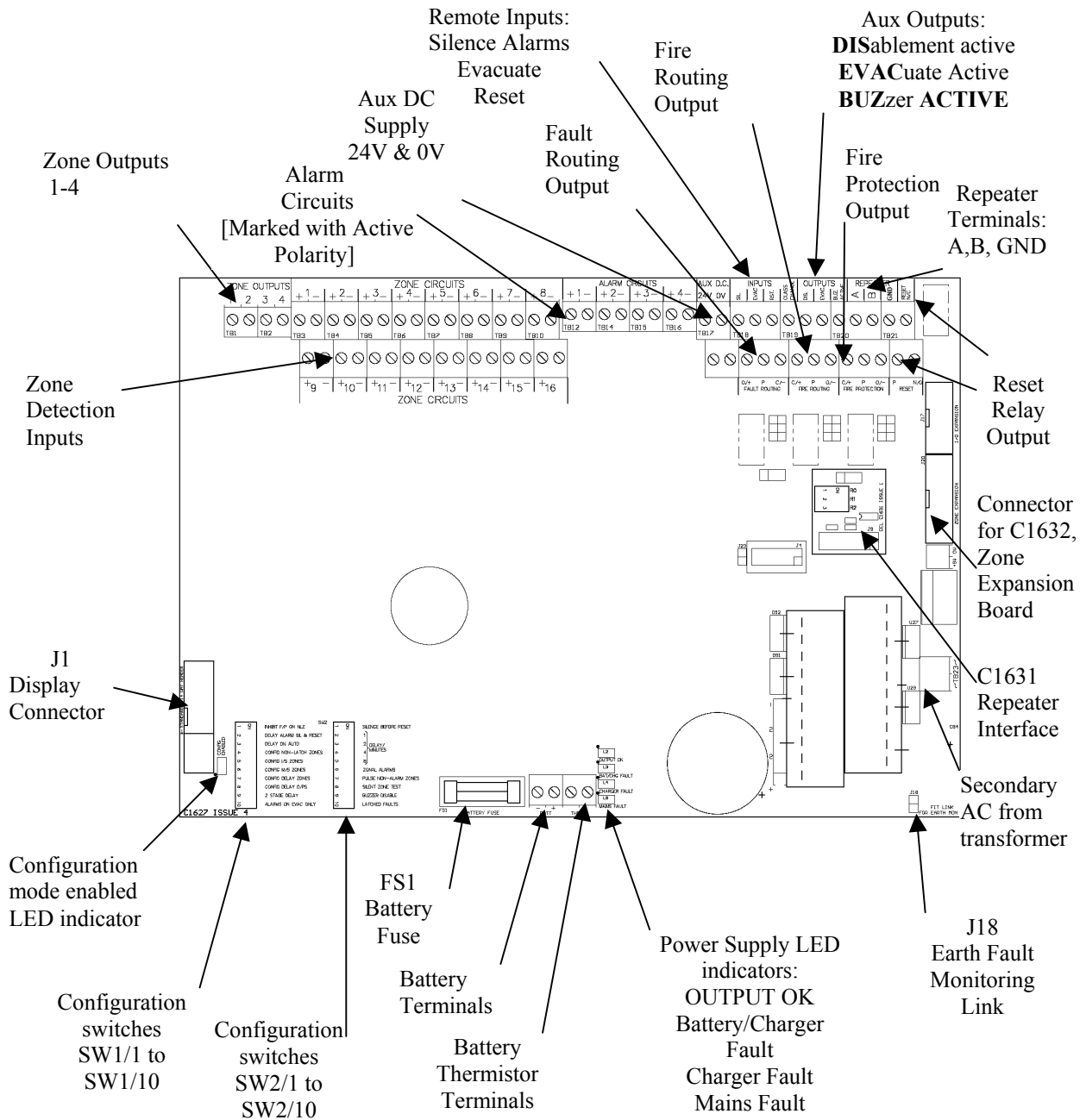

10 Mx-1000 Series C1632 16-Zone Expansion Board Features

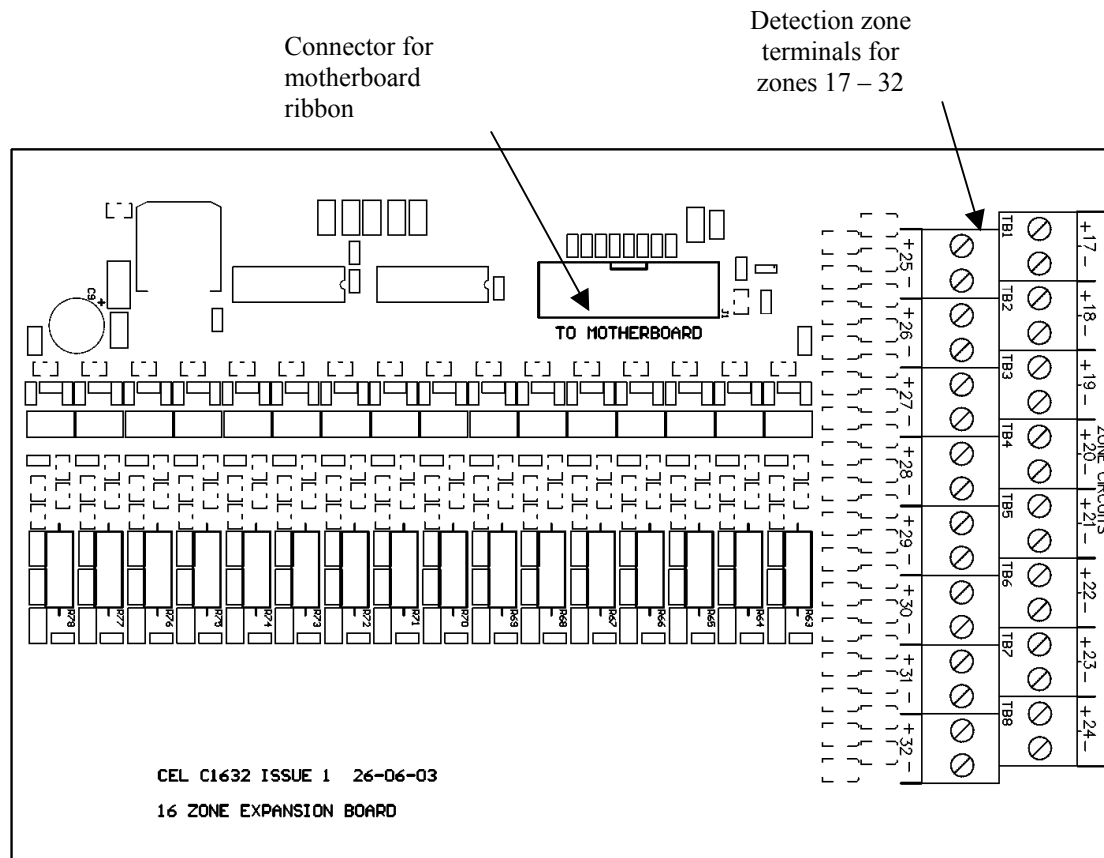

Figure 11 – C1632 16-Zone Expansion Board

11 Power Supplies

The Mx-1002, Mx-1004, Mx-1008 and Mx-1016 panels produce d.c. power regulation directly on the C1627 motherboard. The Mx-1032 zone panel has an off-board power supply via a dedicated PCB (C1652) contained within the enclosure of the fire alarm panel.

For all panels, the output voltage is adjustable from 25V to 28.2V via a small trimmer potentiometer on the PCB. As the output voltage is factory set however, this should not be necessary.

11.1 Visual indications

The following visual indications are provided:

- 1) A green '**Output – OK**' LED. This simply denotes that power is being supplied to the panel
- 2) A yellow '**Batt/Charge Fault**' LED denoting any one of the following conditions:
 - a) Battery disconnected
 - b) Battery fuse blown
 - c) Low Battery voltage
- 3) A yellow '**Charger Fault**' LED. This denotes that the switching regulator has stopped working and could be due to the following reasons:

- a) Switching regulator is malfunctioning
 - b) The power supply output voltage has been incorrectly set to a value less than the terminal voltage of the batteries
- 4) A yellow '**Mains Fault**' LED. This denotes that the mains voltage has failed or is less than the required minimum for correct operation of the power supply.

Note: Fault indications do not become active for a minimum of 10 seconds after the fault has occurred.

11.2 Battery Disconnect

The supply provides a battery disconnect facility which disconnects the batteries when the battery terminal voltage falls below 19.5V.

11.3 32-Zone Power Supply Features And Connections

Figure 12 shows the layout of the 32 zone panel power supply.

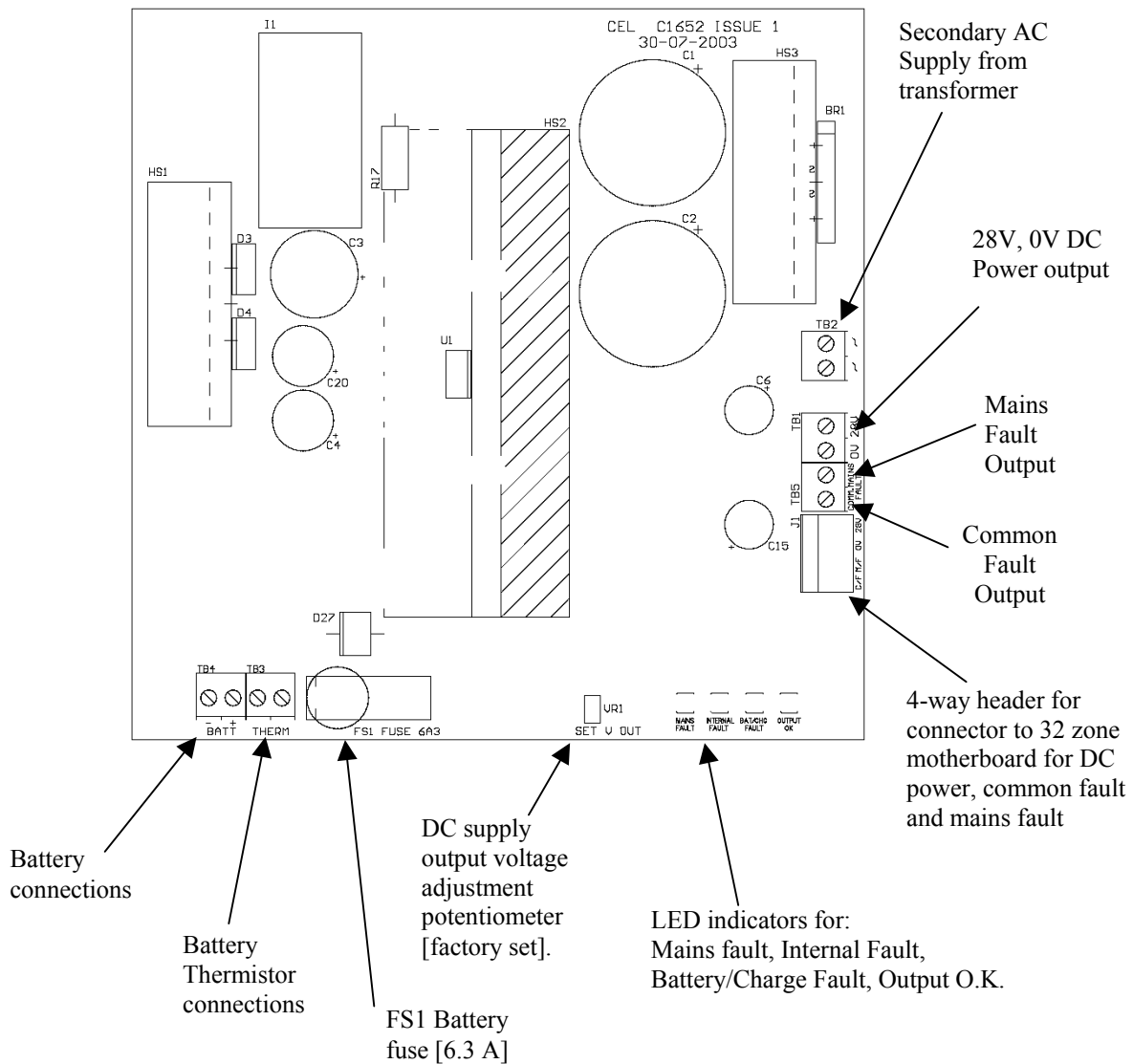

12 Installation

The control panel must be installed by suitably qualified engineers familiar with the installation of fire detection systems. In addition, it is recommended to refer to the following information:

- Current edition of the IEE wiring regulations.
- Current edition of BS5839-1 or the installation standards for the relevant country.
- Any specific site requirements.
- Any field device installation instructions.
- Any data sheet provided for the installation of Intrinsically Safe devices.

Notes:

The rating plate, containing essential electrical information is located inside the panel on the inside face of the door.

The mains supply cable should be a minimum of 1mm² copper protected by a 5A fuse. An appropriate lockable double pole disconnect device shall be provided as part of the building installation. This device must have a minimum contact gap of 3mm.

12.1 Electrical Safety

WARNING: Read this section completely before commencing installation.



Prior to commencing installation of the control panel, ensure that adequate precautions are taken to prevent damage to the sensitive electronic components on the display board and the control board due to electrostatic discharge. You should discharge any static electricity you may have accumulated by touching a convenient earthed object such as an unpainted copper radiator pipe. You should repeat the process at regular intervals during the installation process, especially if you are required to walk over carpets.

The panel must be located in a clean, dry position, which is not subject to shock or vibration and at least 2 metres away from pager systems or any other radio transmitting equipment. The operating temperature range is 0°C to 40°C; maximum humidity is 95%.

12.1.1 IMPORTANT NOTES ON BATTERIES:



DANGER: Batteries are electrically live at all times, take great care never to short circuit the battery terminals.



WARNING: Batteries are often heavy; take great care when lifting and transporting batteries. For weights above 24 kilos, lifting aids should be used.



DANGER: Do NOT attempt to remove the battery lid or tamper with the internal workings of the battery. Electrolyte is a highly corrosive substance, and presents significant danger to yourself and to anything else it touches. In case of accidental skin or eye contact, flush the affected area with plenty of clean, fresh water and seek immediate medical attention.

Valve Regulated Lead Acid (VRLA) batteries are "low maintenance", requiring no electrolyte top-up or measurement of specific gravity.



WARNING: Only clean the battery case with a cloth that has been soaked or dampened with distilled water. Do not use organic solvents (such as petrol, paint thinner, benzene or mineral spirits) or other materials that can substantially weaken the case. Do not use a dry cloth as this will generate static electricity, which in turn may lead to an explosion.



WARNING: Avoid operating temperatures outside the range of -15°C/5°F to +50°C/122°F for float/standby applications.

The recommended normal operating temperature is 20°C.

HIGH TEMPERATURE will reduce battery service life. In extreme cases this

can cause Thermal Runaway, resulting in high oxygen/hydrogen gas production and battery swelling. Batteries are irrecoverable from this condition and should be replaced.

LOW TEMPERATURE will prolong battery life but reduce output capacity.



DANGER:



DANGER
Harmful fumes

Do not incinerate batteries. If placed in a fire, the batteries may rupture, with the potential to release hazardous gases and electrolyte. VRLA batteries contain substances harmful to the environment.

Exhausted batteries must be recycled. Return them to the battery manufacturer or take them to your Council waste disposal site for appropriate disposal.

12.1.2 ELECTRICAL SAFETY:

The volt-free relay contacts provided within the panel must not be used to directly switch any voltage that exceeds 50VAC or 75VDC. (Please also refer to relay rating data).

This equipment requires a 230V AC supply. All installation work should be carried out in accordance with the recommendations of BS5839 Part 1 and the current edition of the IEE regulations by suitably qualified and trained personnel.



Must be
earthed

THIS PANEL MUST BE EARTHED

12.2 Installation Instructions

1. Carefully remove the control panel from the packing and lie the panel on a flat surface.
2. Open the door of the panel.
3. Locate the spares bag and check that the following items are present:

Quantity	Description	Type	
		Mx-1002 / 04	Mx-1008 /16 / 32
1	Mains Fuse	T1AH250V 20mm	T3.15AH250V 20mm
1	Battery Fuse	F2AL250V 20mm	F5AL250V 20mm [8/16] F6.3AL250V 20mm [32]
*	End-Of-Line capacitors for normal zone monitoring	22 μ F, 35 V axial. *[2/4 off]	22 μ F, 35 V axial. *[8/16/32 off]
*	End-Of-Line resistors for alarm circuits and zones configured as Intrinsically Safe.	3k9 0.25W *[4/8 off]	3k9 0.25W *[12/20/36 off]
1	Engineer's door keys	Key Ref.: 801 [Flat key type]	Key Ref.: 801 [Flat key type]
1	Access Control keys	Key Ref.: 801 [Tubular key type]	Key Ref.: 801 [Tubular key type]
1	Positive battery lead	Red	Red
1	Negative battery lead	Black	Black
1	Battery coupling lead	Blue	Blue
4	Battery terminal insulation boot [32 zone panel only]	N/A	Mx-1032 only

12.2.1 Mx-1000 Series Panel Installation Instructions

1. Disconnect the display ribbon cable from the motherboard header.
2. Disconnect the earth strap connecting the door and back-box via the spade terminal on the door.
3. Unscrew the hinge pin at the bottom of the door whilst supporting the door. Swing the bottom of the door clear of the back-box and pull the door away from the top hinge pin.
4. Place the door carefully to one side and replace the bottom hinge pin in the back-box.
5. Unscrew and remove the two lower chassis screws and **only slacken** the top two mounting screws.
6. Carefully lift the chassis upward to align the screw heads with the large holes in the chassis keyholes. Lift the chassis clear of the upper screws and rest the chassis in the bottom of the enclosure. Take care not to strain the wires that remain connected to the back-box.
7. Disconnect the earth strap connecting the backbox and chassis at the earth bar.

8. Disconnect the flying leads from the transformer to the mains terminal block and earth bar.
9. Remove the chassis from the enclosure and place carefully to one side.

NOTE: The door and chassis both contain PCBs with sensitive and fragile electronic components on them. You must place these items in a location where they will not be damaged. Choose an area that is clean, dry and dust-free. You can place the items inside the original packing carton but you must ensure that sufficient soft packing is used to keep the door and chassis separated.

10. Identify the three indented holes in the backbox that are used to mount the enclosure.
11. Place the enclosure in the desired location and mark the position of the top indented hole. Remove the enclosure and fit a suitable fixing to the wall. Hang the enclosure from the top fixing point and ensure that it is level. Mark the locations of the other two mounting holes.
12. Remove the enclosure from the wall and fit suitable fixings to the two remaining mounting points. Fix the enclosure to the wall using all three mounting points.
13. Carefully remove the required knock-outs in the panel enclosure and gland all field wiring in place ensuring that the cable conductors are of sufficient length inside the enclosure. Ensure that all conductors are clearly labelled. **DO NOT remove knock-outs from any unused cable entries. Any unused cable entries which are open must be sealed with a suitable plug (available separately).**
14. Connect the earth drain wires of the field cabling to the brass earth bar positioned at the top of the backbox. Up to two drain wires may be connected to each terminal.
15. Ensure that continuity of any cable shield is maintained through to the last device on the circuit. The shield must only be connected to enclosure earth in the panel by using the earth bars provided. [Different requirements apply for the screen of data cable used for connecting repeaters – see 12.2.2 below].
16. Connect the incoming protective earth conductor to the Earth terminal in the mains terminal block. This is the primary earth point and is labelled  [also labelled E]. See Internal Panel Views
17. Clear any dust and debris from inside the enclosure.
18. Connect the mains-in LIVE cable to the mains terminal block [L terminal] as indicated in Internal Panel Views.
20. Connect the mains-in Neutral cable to the mains terminal block [N terminal] as indicated in Internal Panel Views.
21. Secure the mains-in cable to the cable clamp adjacent the mains terminal using the cable tie supplied. NOTE: The clamp should be over the outer cable insulation.
22. Reinstallation of the chassis is the reverse of removal. Reconnect all wires and ensure none are trapped between the chassis and back-box. Do not connect the field wiring at this stage.
23. Refit the door. The refitting procedure is the reverse of removal. Ensure that the earth strap and ribbon cable are reconnected correctly.
24. Place the left-hand battery into the bottom of the enclosure. The terminals should be positioned towards the centre of the enclosure and the battery should be adjacent to the left side of the back-box, fixed by the raised indents in the back-box, one above the battery and one to the right.

25. Place the right-hand battery into the bottom of the panel. The terminals should be positioned towards the centre of the enclosure and the battery should be adjacent to the right side of the backbox located by the raised indents in the back box above the battery and to the left.
26. Connect the black battery lead to the power supply "Batt -" [battery negative] terminal and connect the red battery lead to the power supply "Batt +" [battery positive] positive terminal [situated on the motherboard for the Mx-1002, Mx-1004, Mx-1008 and Mx-1016 panels and repeater panel or on the separate power supply board in the Mx-1032 panel]. The location of the motherboard battery terminals are shown in Figure 10 – C1627 Motherboard Layout and Figure 12 – 32-Zone Power Supply Layout. Fit the connector on the end of the black lead onto the negative (black) terminal of the left-hand battery. Fit the connector on the end of the red lead onto the positive (red) terminal of the right-hand battery.
28. Connect the blue battery lead between the positive (red) terminal of the left-hand battery and the negative (black) terminal of the right-hand battery. Note that the batteries will not power the panel until the mains supply is energised.

12.2.2 Installation And Connection Of The C1631 Repeater Interface

Warning: Observe anti-static precautions

1. Ensure that the panel and repeaters are powered down and the main and standby supplies are disconnected.
2. On the fire alarm panel and each repeater, remove the jumper link at J22 (adjacent to J9) and fit a C1631 repeater interface to connectors J13 and J9 located immediately to the left of the Zone Expansion ribbon connector on the right-hand side of the C1627 motherboard. The board should be held in place by the 12mm high plastic spacer provided. See Figure 10 – C1627 Motherboard Layout.
3. Connect the RS485 data cable as shown in Figure 13– Repeater Connection Diagram.
4. If the repeater is powered from the panel then connect the Aux 24V d.c. supply from the panel to the repeater.

Notes:

1. Use only RS485 screened data cable.
2. Connect the cable screen to earth only at the fire alarm panel.

Figure 13– Repeater Connection Diagram

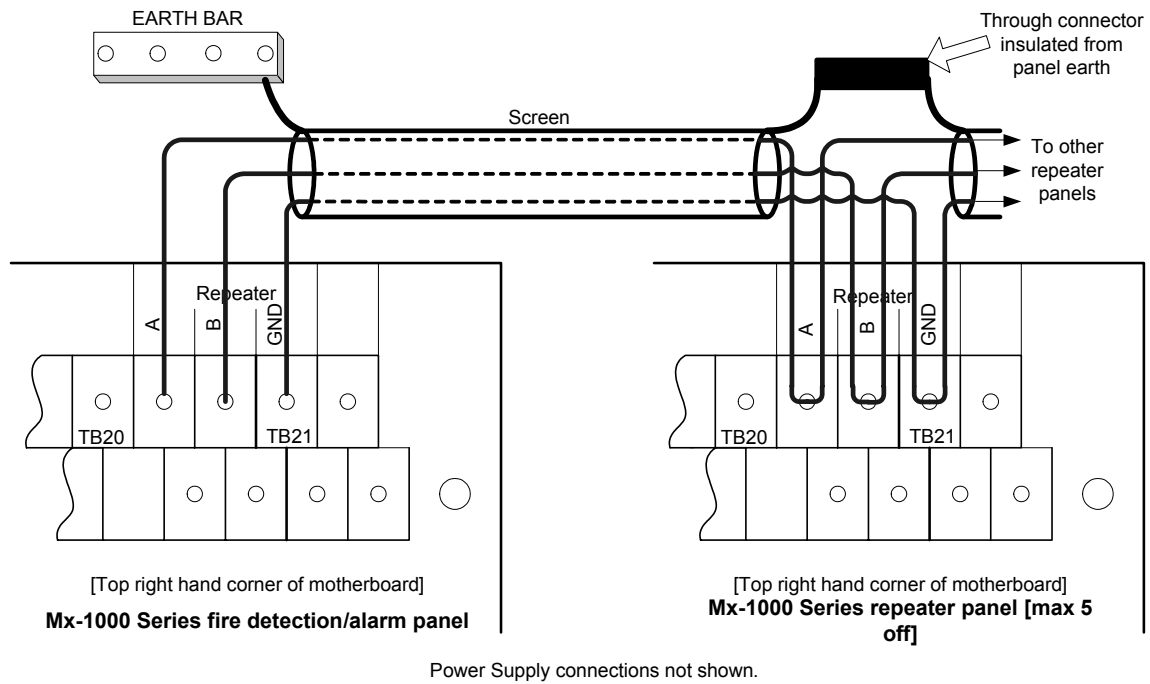

Connect the repeater mains power supply (if required) to the L, N and E terminals as described above for the panel.

13 Commissioning

13.1 Introduction

The following equipment should be available where possible to minimise commissioning time:

- i) VHF/UHF Portable Radio (for two engineers)
- ii) Multi-meter or equivalent

13.2 Commissioning Checklist

1. Before commissioning, the engineer should check the following:
 - i) All field wiring has been inspected and tested in accordance with CEL wiring recommendations, current issues of BS5839:1 and BS7671 IEE wiring regulations.
 - ii) All field cables are glanded into the control panel cabinet.
 - iii) Detector bases are terminated but detector heads are not fitted. Any devices with electronic components are not fitted. Terminations to devices with electronic components should be linked through to maintain cable continuity.
 - iv) Manual Call Points are not connected but cable is linked through to maintain continuity.
 - v) No end-of-line devices (e.g. alarm circuit EOL resistor) are fitted in the field.
2. The following information should be available to the commissioning team:
 - i) Detection layout drawings.
 - ii) Wiring schematic diagram.
 - v) Control Panel installation manuals.
 - vi) Installation manuals for all equipment connected to the system.
 - vii) Site specific configuration details.

Experience has shown that tracing wiring faults on long circuits that are routed through risers etc. can be difficult without knowledge of the wiring route.

It is recommended that the electrical installer be made available until basic wiring continuity is proven. A minimum of two persons (e.g. engineer and mate) is recommended for efficient commissioning.

13.3 An Overview Of The Commissioning Procedure

Commissioning is broken in to 3 sections:

- i) Pre-commissioning wiring check.
- ii) Powering the panel up with no field wiring connected, configuring the panel in accordance with the site-specific requirements and carrying out a functional check.
- iii) Functional testing of all circuits and field devices to check each circuit and function in turn to ensure correct operation of the entire system.

In this way any faults may be located quickly and accurately. The general procedures are as follows:

- Alarm circuits should be checked first. The correct operation of each sounder should be checked for correct audibility as specified in BS5839:1, using the Evacuate function.
- Detection zones should be commissioned next. The purpose is to establish the correct functioning of each device and checking for correct indication at the control panel. The panel responses as configured should be checked at this time.
- All ancillary inputs and outputs should be commissioned and the functionality confirmed.
- Fire protection signals should be tested.

- Fire and fault routing signalling should be tested.

WARNING: Before testing, the engineer must be aware both of the operation of all devices fitted to the auxiliary circuits and of the consequences of their operation.

13.4 Pre-Commissioning Wiring Check

NOTE: This pre-commissioning wiring check procedure should be followed to test all wiring prior to specific commissioning of any detection, alarm and auxiliary circuits.

1. Ensure that no devices are connected to the detection zones and alarm circuits, but that the cables are linked through at the device locations to achieve a continuous circuit.
2. Ensure that the resistance of all cables to earth and between cores is at least $2M\Omega$.

Check the following:

- i) Positive to earth resistance is $2M\Omega$ or greater.
 - ii) Negative to earth resistance is $2M\Omega$ or greater.
 - iii) Positive to negative resistance is $2M\Omega$ or greater.
3. Connect a wire link as the end-of-line device on each of the zones and alarm circuits. At the panel end, measure the resistance across the positive & negative ends of the cables for each of the circuits; ensuring the value does not exceed 20Ω . Remember to remove the wire links after the tests.

Correct polarity throughout all circuits must be maintained. Rectify any faults.

All bells, detector heads and call points should now be connected and the correct end-of-line devices fitted. Use the spare end-of-line devices supplied and leave the EOL devices in the panel terminals at this stage. Remember to remove any links fitted to detector bases. Be very careful to maintain correct polarity at each device.

Warning: Intrinsically safe zone arrangement.

- End-of-line capacitors cannot be connected to zones monitoring Intrinsically Safe detection devices in hazardous areas. To do so will risk causing an explosion in the hazardous area. End-of-line resistors with a value of $3K9\Omega$ must be used, which comply with the requirements laid down in the installation data sheets provided with the I.S. barrier and the I.S. fire detection devices.
- In order for detector head removal monitoring to function correctly when resistors are used as the end-of-line devices, any diodes in the detector bases that are in circuit when the detector head is removed must be disconnected.
- The panel must be configured to monitor Intrinsically Safe zones.
- The first device on an Intrinsically Safe zone must be an I.S. Zener Barrier or Galvanic Isolator. Detectors and Manual Call Points on the Safe side of the barrier are not permitted.
- To comply with the requirements of BS5839, all manual call points should be located in the zone cabling between the I.S. Barrier/Isolator and the first detector. Any manual call point or detector located on the "end-of-line" side of a detector will be rendered inoperative if the detector head is removed.

13.5 Powering up

1. Prior to powering up, the panel will have been installed in accordance with the installation instructions, all cabling will have been fully installed and tested, glanded into the panel enclosure but not connected to the panel terminals. The mains supply should be isolated externally to the panel.
2. Check the battery connections are correct.
3. Remove the mains supply fuse from the panel mains terminal block. Once the permit to energise the mains supply is in place, energise the mains and check the voltage and polarity are correct before replacing the panel fuse.
4. The panel will power up and if all the end of line devices are correctly terminated in the panel and the battery is OK, the panel should be silent, displaying only the Power Supply On indication.
5. Turn the Access keyswitch to "1" and press the Test Display button. The panel should respond by lighting all indications and sounding the buzzer. This will continue for a few seconds after the button is released.

13.6 Configuration.

13.6.1 Basic Default Configuration

When first powered up, the Mx-1000 Series Fire Alarm Panel can be operated in the standard default mode without any additional configuration.

The basic default mode is:

- All zones latching fire, non-delay, standard [non-intrinsically safe]
- Fire Routing, Fire Protection and Sounder outputs not delayed.

13.6.2 Site-Specific Configuration.

It is possible to tailor the functionality of the Mx-1000 Series Fire Alarm Panel in line with site-specific requirements. Details of the site configurable options and the configuration process are provided in sections 13.6 and 15.1 respectively. Charts are provided in the System Log Book for planning/recording the actual configuration. This configuration is not lost when the panel is powered down.

13.7 Commissioning Procedure

After completion of the pre-commissioning wiring check, power-up and configuration, commission the circuits in line with the following guide.

13.7.1 Alarm Circuits

1. Remove the resistor from the first alarm circuit terminal and connect the first alarm circuit wiring to the terminals, observing correct polarity. Check that any alarm fault indications clear after a few seconds.
2. Use the Alarm Test facility [see Mx-1000 Series User Manual] or press Evacuate to operate the sounders. Check that all sounders connected to the alarm circuit operate.
3. Deselect the Alarms Test condition or if "Evacuate" was used, press silence alarms to stop the sounders operating.
4. Repeat steps 1 to 3 for the second and any subsequent alarm circuits.

13.7.2 Commissioning zones

1. Work logically and systematically through each zone.
2. Zone fault conditions:
 - Remove the end-of-line device from the zone 1 terminals and connect the cables of the zone 1 circuit to the panel terminals, observing the correct polarity. Check that any zone 1 fault indications clear after a few seconds.
 - Check the fault monitoring of the cable is correct by applying an open circuit then a short circuit at the end-of-line device (in the field). Check that the fault condition is indicated on zone 1 on the fire panel.
 - Remove the circuit faults, restoring the circuit to the healthy condition and confirm that the fault indication clears.
3. Zone fire conditions
 - Starting with the device nearest the panel, operate each manual call point and detection device on the zone in turn.
 - After operation of each device confirm:
 - The fire indication is provided on the panel on the correct zone.
 - The fire alarm devices operate correctly in line with the panel configuration.
 - The Fire Routing and Fire protection outputs operate correctly in line with the panel configuration.
 - Press the Silence Alarms and the Reset buttons after each device test and check the alarm clears (Manual Call Points must be manually reset before resting the panel).
4. Detector removal operation.
 - Remove the 1st detector along the zone cable [counting from the panel] on zone 1 and observe the following:
 - The appropriate amber zone fault LED illuminates
 - The internal buzzer sounds
 - The fault relay operates
 - For non I.S. zone applications:
 - Operate a manual call point between the detector that has been removed and the EOL capacitor. Check that the panel reacts as described above for a fire condition.
 - Refit the detector, reset the manual call point, press the "Silence Alarms" button and then the "System Reset" button on the panel's display board and check that the control panel returns to its normal state.
 - Repeat for all detectors on the zone.
 - For I.S. zone applications:
 - Remove the 1st detector in the zone cable [counting from the panel] and operate a manual call point ensuring that the correct fire alarm condition is raised on the panel (assuming the installation complies with BS5839).
 - Continue to check the operation of all other manual call points on the zone, resetting the manual call point and silencing/resetting the panel at each stage.
 - Refit the detector and check that the control panel returns to its normal state.

- Continue to test each of the other detectors in turn, checking on each removal that:
 - The appropriate amber zone fault LED illuminates
 - The internal buzzer sounds.
 - The fault relay operates.
- 5. Repeat steps 1 to 4, one zone at a time, until all the zones are commissioned.
- 6. Any faults that are found must be traced and rectified before proceeding.

13.7.3 Commissioning the Class Change Input

1. Connect the Class Change switch to the class change input on the motherboard.
2. Operate the class change switch and observe:
 - i) The alarms sound for 5 seconds then stop.
 - ii) The internal buzzer on the panel **does not** operate.
 - iii) The internal buzzer on repeaters **does not** operate.
3. De-activate the class change switch

13.7.4 Commissioning the Fire and Fault Routing Outputs

1. Remove the resistor from the Fire Routing output circuit terminals and connect the field wiring to the terminals, observing correct polarity. Check that any fault indications clear after a few seconds.
2. To operate the output, initiate a fire condition on a zone. Check that the fire signal is received at the receiving station. Silence and reset the fire alarm panel to clear the output.
3. Remove the resistor from the Fault Routing output circuit terminals and connect the field wiring to the terminals, observing correct polarity. Check that any fault indications clear after a few seconds.
4. Initiate a fault condition on the fire alarm panel to signal a fault to the remote receiving station.
5. Confirm the receipt of the fault warning at the receiving station.
6. Open-circuit the output wiring of each circuit in turn, confirm the fire alarm panel indicates Fire Routing and Fault Routing faults appropriately.
7. Reconnect the cabling and confirm the faults clear.

13.7.5 Commissioning the Fire Protection control signal

1. Ensure any fire protection equipment to be controlled via the Fire Protection output is locked off/safe before attempting any connection, testing or commissioning.
2. Remove the resistor from the Fire Protection output circuit terminal and connect the field wiring to the terminals, observing correct polarity. Check that any fault indications clear after a few seconds.
3. Initiate a fire condition on a zone to operate the output. Check that the fire signal operates the interface relay adjacent the fire protection equipment.
4. Open-circuit the field wiring and confirm that the fire alarm panel indicates Fire Protection output fault.

5. Reconnect the cabling and confirm the faults clear.
6. Final testing and commissioning of the loop through to the fire protection equipment, including test [simulated] activation of the equipment, should be carried out at the appropriate time in conjunction with the engineer responsible for the fire protection system.

13.7.6 Commissioning ancillary inputs

Remote Silence Alarms, Reset and Evacuate inputs should each be tested by the activation of the remote equipment. The response should be verified for each signal.

13.7.7 Commissioning ancillary outputs

The correct operation of equipment connected to the Zone Outputs, Disablement Active, Evacuate Active and Buzzer Active outputs should be verified in turn by initiating a fire condition on each of the appropriate zones; disabling/enabling a zone; operating the Evacuate button on the panel's display.

13.7.8 Commissioning repeaters

1. Power-up the Panel and then the Repeaters. Only the "Power Supply On" LEDs should be illuminated on the Panel and Repeaters.
2. At Repeater 1, turn the Access control switch to "1", and press the "Evacuate" button. Check that the alarms operate and the internal buzzer operates on all repeaters.
3. Press the "Silence" button on the fire alarm panel. Check that the alarm circuits silence and the internal buzzer silences on all repeaters.
4. Repeat steps 2 and 3 for each repeater.
5. Operate a Manual Call Point on zone 1 and check for correct fire indication at each repeater.
6. Press the "Silence Alarms" button on a repeater and check that the alarms are silenced and the Zone 1 fire LED is constantly illuminated on all repeater panels.
7. Press the "Reset" button on a repeater and check that the panel and repeaters return to the quiescent state.
8. Repeat steps 5 to 7 for each zone and ensure "Silence Alarms" and "Reset" operate correctly from each repeater.
9. Set the DIL switches on the C1631 Repeater Interface card in the fire alarm panel OFF (No Repeaters). Check that all repeaters indicate a "Comms. Fault".
10. Set the C1631 Repeater Interface card DIL switches in the fire alarm panel back to their previous settings and check that the repeaters return to normal.
11. Set the first repeater address to 0. Check that the panel indicates a "Repeater fault" and any additional repeaters display a steady "Comms fault" LED.
12. Set the first repeater address back to normal and check that the panel and repeaters return to normal.
13. Repeat steps 11 and 12 for any other connected repeaters.

14 User Controls and Indications

14.1 User Indications [showing optional clock module]

General Indicator Section		
Indicator Description	Colour	Operating Condition
Power Supply On	Green	Steady indication for Mains or Standby power On.
Fire	Red	Flashes on any new fire alarm condition, changing to a steady indication on operation of Silence Alarms.
Fire Routing Active	Red	Steady indication when the Fire Routing Output is active.
General Fault	Yellow	Flashes for any fault condition.
Power Supply Fault	Yellow	Flashes for mains or standby power supply/charge fault
System Fault	Yellow	Steady indication to indicate Microcontroller or Memory Failure. Flashes to indicate Engineer's Configuration Mode active.
Earth Fault	Yellow	Flashes for any positive or negative power supply earth fault.
Fuse Fault	Yellow	Flashes for any auxiliary supply fuse failure
Repeater Fault	Yellow	Flashes for any Repeater fault or repeater communication fault,
Sounder Fault/Disabled	Yellow	Flashes for any sounder fault. Steady for sounders disabled.
Sounder Test	Yellow	Steady indication while sounder walk test is active.
Fire Protection Fault/Disabled	Yellow	Flashes for a fault on the Fire Protection Output. Steady when Fire Protection Output is disabled.
Fire Routing Fault/Disabled	Yellow	Flashes for a fault on the Fire Routing Output. Steady when Fire Routing Output is disabled.
Fault Routing Fault/Disabled	Yellow	Flashes for a fault on the Fault Routing Output. Steady when Fault Routing Output is disabled.

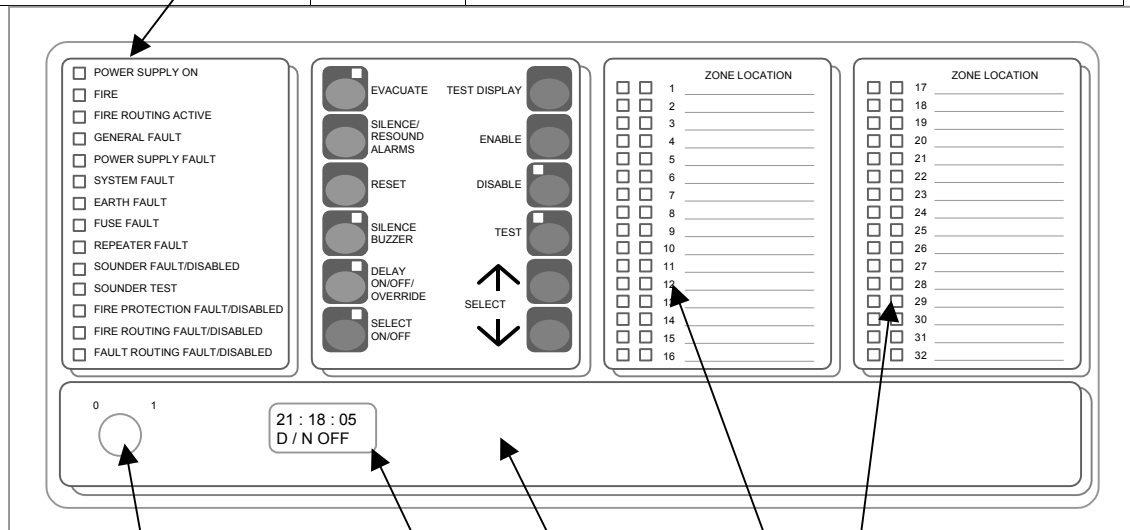

Access Controls Keyswitch:
0 – Controls Locked
1 – Controls Unlocked

User Instructions
Clock Module [Optional]:
Showing time and Day/Night off
Back light flashes for Clock Module fault.

Zone Location Indications		
Indicator Description	Colour	Operating Condition
User Generated Zone Location Text	Red	Flashes when zone is in a fire condition, turning to steady on operation of Silence Alarms.
User Generated Zone Location Text	Yellow	Flashes when zone is in a fault condition. Illuminates steady when zone is disabled or in test.

14.2 User Controls [showing optional clock module]

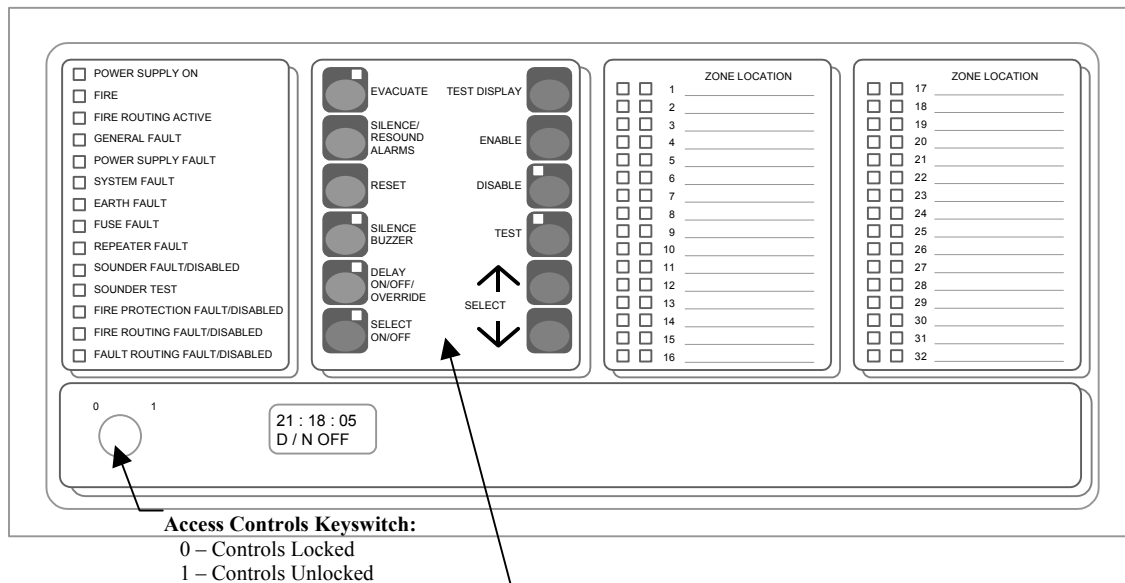

Switch Description	Functionality	Button Availability
Evacuate	Operates all sounders continuously and lights the Evacuated LED adjacent the button until the silence button is operated.	When controls are unlocked
Silence/Resound Alarms	Following a fire alarm condition, 1st operation stops sounders. The General Fire LED and the Zonal fire LED will change from flashing to steady. 2nd operation restarts the previously silenced sounders.	When controls are unlocked
Reset	Clears the panel display, resets the zones, outputs and operates the reset relay.	When controls are unlocked and [if silence before reset is configured] alarms silence switch has been operated.
Silence Buzzer	1] Press to stop the buzzer sounding in fire or fault conditions. 2] In 2 Stage Delay Mode, with stage 1 delay running, press to start stage 2 delay otherwise all delayed outputs operate when Stage 1 timer times out.	When controls are locked or unlocked When the panel is in the fire condition and the delay is running. Controls are locked or unlocked
Delay On/Off/Override	1] Press once to Enable the delay mode, lighting the adjacent delay on LED. Press again to disable the delay mode and turn off the LED 2] Overrides the delay when delay is running, turning the delay mode and the LED off. All delayed outputs will operate immediately.	1] When controls are unlocked and delay period is set to a value > 0. 2] When the panel is in the fire condition and the delay is running.
Select On/Off	Enables the User select feature [Select ↑ Select ↓] for selection of zones or outputs via for disablement/re-enablement and also Day/Night On/Off selection and setting current time on clock module (when fitted).	When controls are unlocked
Test Display	Press to illuminates all LEDs on the display and operate the buzzer. All indications remain active for approx 5 seconds after button release. Also displays alarm counter on clock module (when fitted).	When controls are locked or unlocked
Enable	Press to clear the disablement or test condition on a zone or output selected via the User Select feature.	When controls are unlocked, the Select switch has been operated and a zone or output has been selected.
Disable	Press to disable a zone or output selected via the User Select feature.	As above.
Test	Press to initiate the One Man Test on sounders or zones as selected via the User Select feature.	As above.
Select ↑ Select ↓	Used to scroll the cursor indication through the zone and output fault LEDs on the display to select a zone or output for disablement, or test. [LED illuminated when Select Mode is active]. Also scrolls through clock module menu (when fitted).	When controls are unlocked and the Select switch has been operated.

15 Operating the Engineer's functions

15.1 Engineer's Zone/Output Configuration Process:

- Various programmable configuration options associated with the zonal inputs and outputs can be enabled/disabled by operating the appropriate DIL switch located within the panel enclosure. These are:
 - Configure zones as delayed zones.
 - Configure zones for use with I.S. barriers/isolators.
 - Configure zones as latching/non-latching fire indication.
 - Configure zones to short circuit fire mode.
 - Configure outputs to be delayed.

Note: Configure Machinery Space Zones feature is not used on the standard Mx-1000 Series panels.

15.2 Zone or Output Configuration

- 1. Select a programmable configuration mode:
 - Enable the controls on the display, by turning the Access key-switch on the panel display to the "1" position.
 - If the panel is in the fire alarm condition, silence the alarms and reset.
 - Open the panel door and locate the appropriate DIL switch on the motherboard [**Config Non-latch Zones; Config I.S. Zones; Config Delay Zones; Config Delay O/Ps**] and move the switch actuator to the ON position.
 - The CONFIG ENABLED LED on the motherboard will illuminate.
 - The Panel's System Fault LED will flash and the buzzer will operate.
 - The Select LED on the front of the display will pulse.
 - Any standing fire or fault alarm indications and associated outputs will be inhibited.
 - If active, the indications for evacuation, silence buzzer, delay on or disablement indications will clear.
 - The panel will indicate the current status of the selected programmable configuration mode on the yellow fault/disabled LEDs on the Zones, Sounders, Fire Routing and Fire Protection outputs.

A steady indication denotes that the zone/output is already configured to the selected mode.

No indication denotes that the zone/output has not been configured to the selected mode.

- Close the panel door to allow access to the buttons on the display.
- 2. Select a zone or output to be configured:
 - On the panel display, press the Select On/Off switch to enable the Select Mode.
 - The Select LED will become steady and the panel buzzer will silence.
 - A pulsing indication [cursor] will appear either on the Zone 1 Fault/Disabled LED or the Sounder Fault/Disabled LED/Test depending upon which configuration DIL switch is selected.
 - Use the Select ↑ and Select ↓ buttons to scroll the cursor indication through the selectable options:
 - For zonal configuration, through all zones sequentially in forward [Select ↓] or reverse [Select ↑] sequence starting at zone 1.

- For Output Delay configuration, through Sounders, Fire Protection and Fire Routing outputs in forward [Select ↓] or reverse [Select ↑] sequence starting at Sounders.
- 3. To change the configuration of a selected zone or output:
 - With the cursor flashing on the selected zone or output:
 - Operation of the ENABLE button will apply the configuration functionality to the selected zone/output causing the associated fault/disabled LED to provide a continuous indication.
 - Operation of the DISABLE button will clear the configuration from the selection and restore normal operation. The fault/disabled LED will clear.
 - By repeating steps 2 and 3, any number of zones [or outputs] can be configured.
- 4. To quit the programmable configuration mode:
 - To return the panel to normal operating mode applying the updated configuration:
 - Open the panel door and return the selected Config DIL switch on the motherboard to the OFF position.
 - The CONFIG ENABLED LED on the motherboard will clear, the panel buzzer will silence and the flashing System Fault indication and zone/output configuration status indications on the display will clear as will the cursor and the Select indications. Any current alarms, disablements, will be re-indicated along with any active status indications [Delay on etc.].
 - Close and lock the panel door.
 - Return the ACCESS keyswitch to the “0” position to disable the controls on the display.

IMPORTANT NOTE: WHILE THE PANEL IS IN THE ENGINEER'S ZONAL/OUTPUT CONFIGURATION MODE, ALL ZONAL INPUTS ARE IN PERMANENT RESET AND OUTPUTS ARE INHIBITED – THE PANEL WILL NOT RESPOND TO ANY FIRE ALARM.

15.3 To Restore the Factory Default Configuration for Zones & Outputs:

- Open the panel door and locate the DIL switches SW1-4 to SW1-8 on the motherboard [Config Non-latch Zones; Config I.S. Zones; Config M/S Zones; Config Delay Zones; Config Delay O/Ps] and move the switch actuator on each switch to the On position.
 - The Config Enabled LED on the motherboard will flash.
 - The Panel's System Fault LED will flash and the buzzer will operate.
 - Any standing fault or disablement indications will clear.
 - It will not be possible to enter the Select Mode.
- Press the Disable button on the panel's display.
- Return DIL switches 1-4 to 1-8 to the OFF position.
 - The Config Enabled LED on the motherboard will clear.
 - The Panel's System Fault LED will flash and the buzzer will clear.
 - The factory default configuration [all zones as latching fire, non-delay, standard [non-intrinsically safe] will be restored and the Fire Routing, Fire Protection and Sounder outputs will no longer be delayed

15.4 Engineer's Zone/Output Configuration Time-out Warning:

This feature is provided to prevent the panel being left in the Zone/Output Configuration condition.

- 1 minute after the last button press:
 - The panel buzzer will restart.
 - The Select LED will flash.
 - The System Fault LED will continue flashing.
- Press the Select On/Off button to continue with the configuration process otherwise quit the configuration process as described in 15.2.4 above

15.5 Invalid Configuration conditions:

- Invalid condition: If 2 or more configuration switches on the motherboard are in the ON position at the same time:
 - The Config LED on the motherboard will flash.
 - The System Fault and Select LEDs on the display will flash.
 - The fault relay will operate.
 - The panel buzzer will sound.
 - The Cursor indication will clear.
 - Configuration will be inhibited.
- To clear the invalid condition check the zone and output config switches [1/4, 1/5, 1/6, 1/7, 1/8] on the motherboard and ensure that only one is selected to ON.
- Invalid condition: Selecting any config mode switch [1/4, 1/5, 1/6, 1/7, 1/8] to the ON position whilst the panel is in the fire condition.
 - The Config LED on the motherboard will flash.
 - The System Fault and Select LEDs on the display will flash.
 - The panel buzzer will sound.
 - The Cursor indication will clear.
 - Configuration will be inhibited.
- To clear the invalid condition, select the config switch to OFF. Reset the fire alarm condition before attempting the configuration process again.

15.6 List of configuration DIL switches and their functions

- SW 1/1 - Inhibit F/P on NLZ:

Selects Fire Protection relay to operate **or** not to operate for a fire condition on any zone configured to non-latched mode.

 - OFF Fire Protection relay operates for a fire condition on any zone configured to non-latched mode.
 - ON: Fire Protection relay does not operate for a fire condition on any zone configured to non-latched mode.
 - [Not EN54 compliant function].
- S/W 1/2 - Delay Alarm Sil & Rst:
 - OFF: Silence and reset available as normal.
 - ON: Prevents alarms being silenced or reset for a period of 3 minutes after a fire alarm condition occurs.
 - [Not EN54 compliant function].

- SW 1/3 – Delay On Auto:
 - OFF: Automatically turn off the delay mode once a day at the set time [the delay mode first being turned on manually].
 - ON: Automatically turn the delay mode on once a day and off once a day at the set times.
 - Requires optional clock module.
- SW 1/4 - Config Non-Latch Zones:
 - OFF: Configuration mode disabled.
 - ON: Enables selected zones to be configured to non-latching fire mode via the Engineer's Select feature.
 - [Not EN54 compliant function].
- SW 1/5 - Config I/S Zones:
 - OFF: Configuration mode disabled.
 - ON: Enables selected zones to be configured to Intrinsically Safe alarm thresholds and passive end of line fault monitoring via the Engineer's Select feature. [For use with appropriate I.S. barriers/Isolators, typically 330 Ohm zener barriers or galvanic isolators].
 - [Not EN54 compliant function. Provided to meet existing customer requirements.]
- SW 1/6 - Config M/S Zones:
 - OFF: Configuration mode disabled.
 - ON: Enables selected zones to be configured to short circuit fire mode via the Engineer's Select feature.
- SW 1/7 - Config Delay Zones:
 - OFF: Configuration mode disabled.
 - ON: Enables selected zones to be configured to Delay Mode via the Engineer's Select feature.
- SW 1/8 - Configure Delay O/Ps:
 - OFF: Configuration mode disabled.
 - ON: Enables the selection of outputs, via the Engineer's Select feature, to which the panel delay will apply.
- SW 1/9 - 2 Stage Delay:
 - OFF: Single Stage Delay Mode.
 - ON: Two Stage Delay Mode.
- SW 1/10 - Alarms on Evac Only:
 - OFF: Sounders operate on any fire condition including evacuate.
 - ON: Selects sounders to operate only when the panel is in the evacuate condition
 - [Not EN54 complaint function. Provided to meet existing customer requirements.]
- SW 2/1 - Silence Before Reset:

Select type of reset mode. [Not EN54 compliant function. Provided to meet existing customer requirements]:

- OFF: Reset available when panel is in the [un-silenced] fire or fault condition.
 - ON: Fire Condition Reset available only when panel is in Alarm Silenced condition. Fault reset available when panel is in the fault condition.
- SW 2/2 to 2/5 - Delay/Minutes:

Sets the duration of the variable time delay element [i.e. the single stage delay and stage 2 of the two stage delay] in steps of 1 minute within the range 0-9 minutes. See Table 1 - Delay Switch Settings

Table 1 - Delay Switch Settings

Delay Duration	S/W 2/2	S/W 2/3	S/W 2/4	S/W 2/5
Delay disabled	Off	Off	Off	Off
1 min	On	Off	Off	Off
2 min	Off	On	Off	Off
3 min	On	On	Off	Off
4 min	Off	Off	On	Off
5 min	On	Off	On	Off
6 min	Off	On	On	Off
7 min	On	On	On	Off
8 min	Off	Off	Off	On
9 min	On	Off	Off	On
10 min	Off	On	Off	On
10 min	On	On	Off	On
10 min	Off	Off	On	On
10 min	On	Off	On	On
10 min	Off	On	On	On
10 min	On	On	On	On

- SW 2/6 - Enable Zonal Alarms:

Select the type of sounder alarm response to a fire condition in conjunction with the Pulse Non Alarm Zones switch described below. [Not EN54 compliant function. Provided to meet existing customer requirements] :

- OFF: General Alarm Mode – all sounders operate continuously until silenced.
- ON: Zonal Sounder Mode - Sounder groups for zones not in the alarm condition may be selected, via the Pulse Non Alarm Zones switch [SW 2/7], to pulse or not to operate.

Note: Zonal alarms on the 2/4 zone panel affects the standard sounder circuits on the motherboard. On the 8, 16 and 32 zone panels, it affects only the [future] expansion module sounder circuits.

- SW 2/7- Pulse Non Alarm Zones:

Select the type of zonal sounder alarm response to a fire condition in conjunction with the Zone Alarms switch [SW 2/6] described above. [Not EN54 compliant function. Provided to meet existing customer requirements]:

With the Zone Alarms switch [SW 2/6] in the On position [Zonal Sounder Mode]:

- SW2/7 OFF: Zonal sounders for zone in the fire condition operate continuously until silenced. All others are silent.
- SW2/7 ON: Zonal sounders operate continuously - all other sounders operate in pulsed mode until silenced.

- SW 2/8 - Silent Zone Test:

Select sounder response in One Man [Detector] Test Mode:

- OFF: Sounders operate once on each test.
- ON: Sounders do not respond to a zone test.

- SW 2/9 - Buzzer Disable:

Enable/disable panel fire/fault buzzer.

- OFF: Buzzer is enabled.
- ON: Buzzer is disabled. General Disablement LED illuminated.
- [Not EN54 compliant function. Provided for commissioning purposes.]

- SW 2/10 - Latched Faults:

When enabled, all fault conditions latch until the Reset switch is operated.

- OFF: Non-latched faults.
- ON: Latched faults.

15.7 Configurable Options via DIL switch selection on Repeater Interface Board:

DIL switch SW1 on the C1631 Repeater Interface PCB is used to set the quantity of repeaters and the repeater addresses as follows:

- To set the repeater quantity, set SW1 on the C1631 fitted to the fire alarm panel in line with Table 2 - C1631 setting for quantity of repeaters.

Table 2 - C1631 setting for quantity of repeaters

SW 1	Repeater Quantity					
	0	1	2	3	4	5
1-1	Off	On	Off	On	Off	On
1-2	Off	Off	On	On	Off	Off
1-3	Off	Off	Off	Off	On	On

- To set the addresses of the individual repeater panels, set SW1 on the C1631 fitted to each repeater panel in line with Table 3 - C1631 setting for repeater addresses. Note that each repeater must have a different address.

Table 3 - C1631 setting for repeater addresses

SW 1	Repeater Address					
	0 *	1	2	3	4	5
1-1	Off	On	Off	On	Off	On
1-2	Off	Off	On	On	Off	Off
1-3	Off	Off	Off	Off	On	On

* Note: Address 0 = repeater disabled.

15.8 Configuring the Fire Routing, Fire Protection and Fault routing O/Ps

To configure the Fire Routing Output to volt-free relay contacts, remove links J10, J11 and J12. [These links are combined in a single block].

To configure the Fire Protection Output to volt-free relay contacts, remove links J14, J15 and J16. [These links are combined in a single block].

To configure the Fault Routing Output to volt-free relay contacts, remove links J6, J7 and J8. [These links are combined in a single block].

These links are located below the associated output in the top right hand section of the C1627 motherboard. See Figure 10 – C1627 Motherboard Layout

15.9 Enable/disable earth fault monitoring.

To disable the earth fault monitoring, remove the link J18 located towards the bottom right hand corner of the C1627 motherboard. See Figure 10 – C1627 Motherboard Layout.

16 Optional Clock Module – Configuration and Setting

16.1 Standard Module Engineer Mode:

16.1.1 To Zero the Alarm Counter:

Open panel door and move the DIL switch 1, pole 2 on the clock module PCB to the ON position. Return the DIL switch to the OFF position.

16.1.2 To Access the Engineers Clock Module Edit Functions:

Select the Access Control key switch to position “1”.

Press SELECT ON/OFF button.

Use the ↑↓ buttons to scroll the cursor LED indication through the selectable options on the panel display LED indications until the LCD backlight illuminates. The normal time display is:

HH:MM:SS D/N ON	or	HH:MM:SS D/N OFF
--------------------	----	---------------------

- To select Day/Night Mode On/Off:
 - Press the SELECT ON/OFF button to enter Day/night mode On/Off Set Display:

D/N ON Change?	or	D/N OFF Change?
-------------------	----	--------------------

- On the rear of the Clock Module PCB, move the DIL switch 1, pole 1 to the ON position. Pressing ENABLE (+) or DISABLE (-) toggles the setting between D/N ON and D/N OFF.
- To set the current time:
 - Press SELECT ↓ to enter the current Time Set Display:

HH:MM:SS Time Set	HH flashing
----------------------	----------------

- Press ENABLE (+) or DISABLE (-) to adjust the hours (HH) to the desired value (0-23).
- Press SELECT ↓ to select the minutes:

HH:MM:SS	MM
Time Set	flashing

- Press ENABLE (+) or DISABLE (-) to adjust the minutes (MM) to the desired value (0-59).
- Press SELECT ↓ to select the seconds:

HH:MM:SS	SS
Time Set	flashing

- Press ENABLE (+) or DISABLE (-) to adjust the seconds (SS) to zero.
- To set Day/Night Mode On Time
 - Press SELECT ↓ to access the Day/Night Mode On Time Set Display:

HH:MM:SS	HH
ON Time	flashing

- Press ENABLE (+) or DISABLE (-) to adjust the hours (HH) to the desired value (0-23).
- Press SELECT ↓ to access select the minutes:

HH:MM:SS	MM
ON Time	flashing

- Press ENABLE (+) or DISABLE (-) to adjust the minutes (MM) to the desired value (0-59).
- Press SELECT ↓ to access select the seconds:

HH:MM:SS	SS
ON Time	flashing

- Press ENABLE (+) or DISABLE (-) to adjust the seconds (SS) to the desired value (0-59).

- To set Day/Night Mode Off Time
 - Press SELECT ↓ to access the Day/Night Mode On Time Set Display:

HH:MM:SS	HH
OFF Time	flashing

- Press ENABLE (+) or DISABLE (-) to adjust the hours (HH) to the desired value (0-23).
- Press SELECT ↓ to access select the minutes:

HH:MM:SS	MM
OFF Time	flashing

- Press ENABLE (+) or DISABLE (-) to adjust the minutes (MM) to the desired value (0-59).
- Press SELECT ↓ to access select the seconds:

HH:MM:SS	SS
OFF Time	flashing

- Press ENABLE (+) or DISABLE (-) to adjust the seconds (SS) to the desired value (0-59).
- Press SELECT ↓ to exit to the Delay On/Off Set Display:

D/N ON	D/N OFF
Change?	Change?

Pressing SELECT ↓ repeats the cursor/display changes as above.

Pressing SELECT ↑ repeats the cursor/display changes as above in reverse.

- To exit Clock Module Menu:
 - Return the WP DIL switch on the Clock Module to OFF position.
 - Press SELECT ON/OFF: Module switches off the LCD backlight and exits configuration mode. The normal time display is:

HH:MM:SS	or	HH:MM:SS
D/N ON		D/N OFF

- On completion of editing, return the Access Control key switch to position "0".

16.2 Configuring the Clock Module

The Clock Module is configured by setting Link 1 and DIL switch 1. These are both located on the rear of the C1651 Clock Module PCB [accessed by opening the panel door].

Link 1	
Position Selected	Function
Fitted	1 st Fire Alarm Time Mode selected
Removed	Day/Night Mode selected

Link 1	DIL Switch 1		
	Pole	Position Selected	Function
Removed	1	Left [Off]	Clock Module Menu configuration disabled
	1	Right [On]	Clock Module Menu configuration enabled
Fitted	1	Left [Off]	No effect
	1	Right [On]	No effect
Removed	2	Left [Off]	Day/Night mode and Fire Event Counter mode enabled.
Removed	2	Right [On]	Day/Night mode and Fire Event Counter mode disabled. [To zero the Fire Event Counter, select "On" momentarily then return to "Off"].
Fitted	2	Left [Off]	1 st Alarm Fire Time and Fire Event Counter Mode enabled
Fitted	2	Right [On]	1 st Alarm Fire Time and Fire Event Counter Mode disabled. [To zero the Fire Event Counter, select "On" momentarily then return to "Off"].

Table 4 – C1651 Clock Module DIL switch 1 and Link 1 Settings

16.3 C1651 Clock Module PCB Features

Figure 14 illustrates the PCB features referred to elsewhere in the documentation

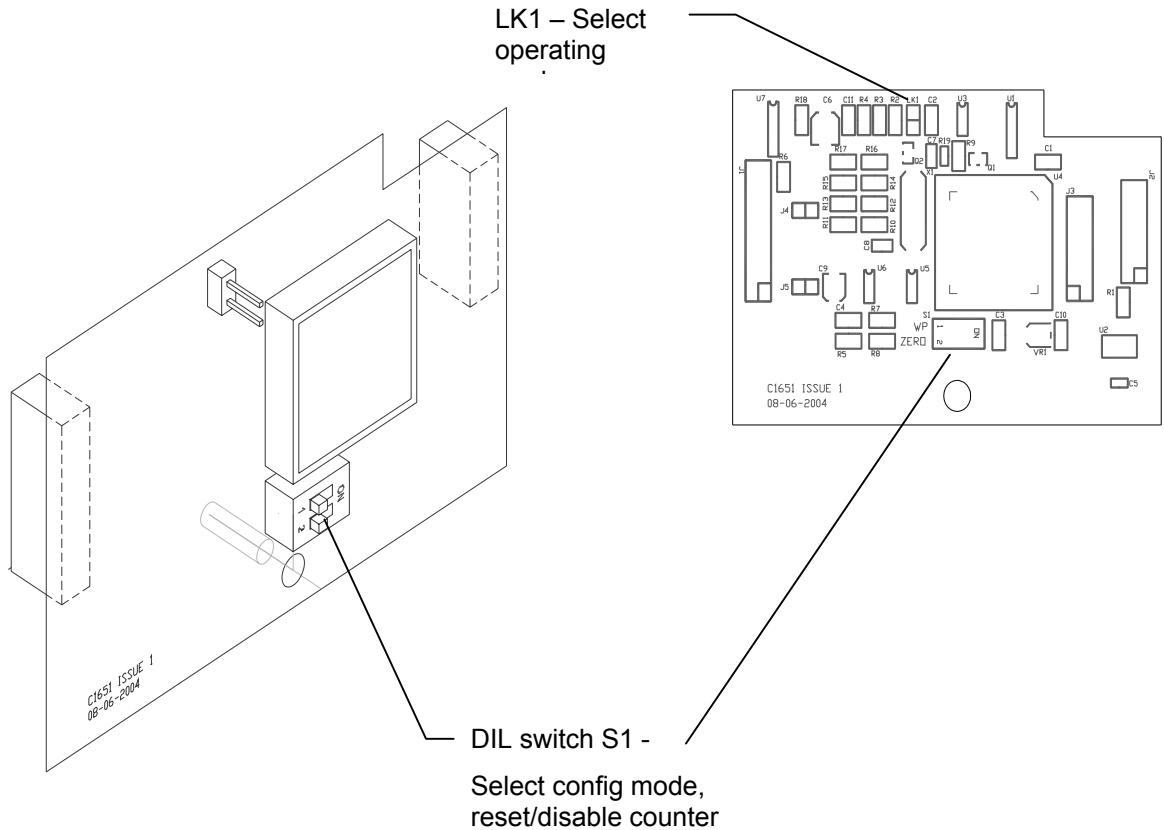

Figure 14 – C1651 Clock Module PCB

16.4 Clock Module Error Messages

16.4.1 WP DIL Switch Error Message:

WP DIL Switch is operated when the timer is not in Timer Set Mode, the normal display flashes with WP DIL switch message:

HH : MM : SS D/N ON	or	HH : MM : SS D/N OFF
------------------------	----	-------------------------

Changes to (pulses every second):

WP DILSW IS ON

The backlight remains OFF. The panel indicates a general fault and prevents the clock module from being accessed by the user/engineer.

16.4.2 EEPROM Error Message:

Data inconsistency has been detected in EEPROM0 or EEPROM1:

EEPROM 0 ERROR	or	EEPROM 1 ERROR
-------------------	----	-------------------

Note: Both EEPROM devices can be erased by the following procedure:

1. Power down the panel.
2. Place the WP DIL switch in th ON position.
3. Powe the panel back up.
4. Return the WP DIL switch to the OFF position when the display is as described in 16.4.1 above.

16.4.3 ROM Checksum Error message:

Internal ROM checksum failed:

ROM FAIL ERROR

17 Mechanical, Electrical & Environmental Specification

Mechanical Specification	Mx-1000 Series Panel				Repeater		
	2/4 zone	8 zone	16 zone	32 zone	2-8 zone	16 zone	32 zone
Size [mm] Height: Width: Depth:	340 325 95	370 325 126	370 325 126	441 400 131	340 325 95	340 325 95	441 400 131
Weight excluding batteries:	5.65Kg	7.05Kg	7.05Kg	9.35Kg	5.65Kg	5.65Kg	7.6Kg

Mains Input Specification	Mx-1000 Series Panel				Repeater		
	2/4 zone	8 zone	16 zone	32 zone	2-8 zone	16 zone	32 zone
Maximum Input Power:	85W	165W	165W	240W	85W	85W	85W
Protection: [Warning: Replace only with identical type & rating of BEAB or VDE approved fuse]	T1A H250V [1A anti-surge]	T3.15A H250V [3.15A anti-surge]	T3.15A H250V [3.15A anti-surge]	T3.15A H250V [3.15A anti-surge]	T1A H250V [1A anti-surge]	T1A H250V [1A anti-surge]	T1A H250V [1A anti-surge]
Voltage:	230V AC +10%/-15%						
Cable requirements:	Minimum of 1mm ² copper protected by a 5A fuse.						

Power Supply Output Specification	Mx-1000 Series Panel				Repeater		
	2/4 zone	8 zone	16 zone	32 zone	2-8 zone	16 zone	32 zone
Maximum Current Output, Mains On	1.5A	3A	3A	5A	1A	1A	1A
Voltage Output, Mains On	26.5 - 28.6V						
Maximum Current Output, Mains Failed	1.5A	3A	3A	5A	1A	1A	1A
Voltage Output, Mains Failed	19.2 - 27V						
Output protection:	Electronic current limiting						
Common fault output:	N/A	N/A	N/A	50mA	N/A	N/A	N/A
Mains failed fault output:	N/A	N/A	N/A	50mA	N/A	N/A	N/A

Battery Specification	Mx-1000 Series Panel				Repeater		
	2/4 zone	8 zone	16 zone	32 zone	2-8 zone	16 zone	32 zone
Battery charger output: [Temperature compensated float charger 28.6V ±0.1V@-5°C 26.5 V±0.1V@ +40 °C.]	1.5A	3A	3A	5A	1.5 A	1.5 A	1.5 A
Battery type: POWERSONIC [Warning: Replace only with identical battery]	2 off PS1230 [12V 3Ah]	2 off PS1270 [12V 7Ah]	2 off PS12120 [12V 12Ah]	2 off PS12180 [12V 18Ah]	2 off PS1230 [12V 3Ah]	2 off PS1230 [12V 3Ah]	2 off PS1230 [12V 3Ah]
Battery size: [For one 12 V pack]	134mm x 67mm x 60mm	151mm x 65mm x 94mm	151mm x 98mm x 94mm	180mm x 76 mm x 167mm	134mm x 67mm x 60mm	134mm x 67mm x 60mm	134mm x 67mm x 60mm
Battery circuit protection: [Warning: Replace only with identical type & rating of fuse]	F2AL250V 20mm fast blow glass fuse	F5AL250V 20mm fast blow glass fuse	F5AL250V 20mm fast blow glass fuse	F6.15AL250V 20mm fast blow glass fuse	F2AL250V 20mm fast blow glass fuse	F2AL250V 20mm fast blow glass fuse	F2AL250V 20mm fast blow glass fuse
Mains failed fault battery current:	45mA	45mA	45mA	55mA	40mA	40mA	40mA
Mains failed alarm battery current:	80mA	80mA	80mA	90mA	75mA	75mA	75mA

Environmental Specification	All Panels
Operating temperature:	-5°C to 40°C
Operating humidity:	5% to 95%

Free Manuals Download Website

<http://myh66.com>

<http://usermanuals.us>

<http://www.somanuals.com>

<http://www.4manuals.cc>

<http://www.manual-lib.com>

<http://www.404manual.com>

<http://www.luxmanual.com>

<http://aubethermostatmanual.com>

Golf course search by state

<http://golfingnear.com>

Email search by domain

<http://emailbydomain.com>

Auto manuals search

<http://auto.somanuals.com>

TV manuals search

<http://tv.somanuals.com>