

# Bradyprinter™ THT

## *200M-e/200M-e 300*

### User's Guide

Customer order # 11342L-12  
Manufacturer part # 11342LB-12 Rev. 1



## **Proprietary Statement**

This manual contains proprietary information of Brady Corporation. It is intended solely for the information and use of parties operating and maintaining the equipment described herein. Such proprietary information may not be used, reproduced, or disclosed to any other parties for any other purpose without the expressed written permission of Brady Corporation.

## **Product Improvements**

Continuous improvement of products is a policy of Brady Corporation. All specifications and signs are subject to change without notice.

## **FCC Compliance Statement**

**NOTE:** This equipment has been tested and found to comply with the limits for a Class B digital device, pursuant to Part 15 of the FCC Rules. These limits are designed to provide reasonable protection against harmful interference in a residential installation. This equipment generates, uses and can radiate radio frequency energy and, if not installed and used in accordance with the instructions, may cause harmful interference to radio communications. However, there is no guarantee that the interference will not occur in a particular installation. If this equipment does cause harmful interference to radio or television reception, which can be determined by turning the equipment off and on, the user is encouraged to try to correct the interference by one or more of the following measures:

- Reorient or relocate the receiving antenna.
- Increase the separation between the equipment and the receiver.
- Connect the equipment into an outlet on a circuit different than that to which the receiver is connected.
- Consult the dealer or an experienced Radio/TV technician for help.

**NOTE:** This unit was tested with shielded cables on the peripheral devices. Shielded cables must be used with the unit to ensure compliance.

“The user is cautioned that any changes or modifications not expressly approved by Brady Corporation could void the user’s authority to operate the equipment.”

## **Canadian DOC Compliance Statement**

This digital apparatus does not exceed the Class A limits for radio noise emissions from digital apparatus as set out in the radio interference regulations of the Canadian Department of Communications.

## **CE Compliance**

If the accompanying printer displays the CE mark, it also meets EMC directive 89/336/EEC, with amendments effective at the time of manufacture.

## **Liability Disclaimer**

Brady Corporation takes steps to assure that its published Engineering Specifications and Manuals are correct; however, errors do occur. Brady Corporation reserves the right to correct any such errors and disclaims liability resulting therefrom.

## **No Liability for Consequential Damage**

In no event shall Brady Corporation or anyone else involved in the creation, production, or delivery of the accompanying product (including hardware and software) be liable for any damages whatsoever (including, without limitation, damages for loss of business profits, business interruption, loss of business information, or other pecuniary loss) arising out of the use of or the results of use of or inability to use such product, even if Brady Corporation has been advised of the possibility of such damages. Because some states do not allow the exclusion or limitation of liability for consequential or incidental damages, the above limitation may not apply to you.

## **Copyrights**

This copyrighted manual and the label printers described herein are owned by Brady Corporation. All rights are reserved. Unauthorized reproduction of this manual or the software in the label printer may result in imprisonment or up to one year and fines of up to \$10,000 (17 U.S.C.506). Copyright violators may be subject to civil liability.

All products and brand names are trademarks of their respective companies. All rights reserved.

© 2002 Brady Corporation. All rights reserved.

# DECLARATION OF CONFORMITY

I have determined that the Zebra printers identified as the

*Bradyprinter™ 200M-e and 200M-e 300*

manufactured by:

**Zebra Technologies Corporation**

333 Corporate Woods Parkway  
Vernon Hills, Illinois 60061-3109 U.S.A.

has been shown to comply with the applicable technical standards of the FCC

for Home, Office, Commercial, and Industrial use

if no unauthorized change is made in the equipment,  
and if the equipment is properly maintained and operated.

  
Clive Kenney



For Technical Support Service, call us directly at **1-800-643-8766** or visit our web site: **<http://www.bradyid.com>**.

## **W.H. BRADY CO. CUSTOMER SERVICE FORM**

This form should be completed in full before requesting technical assistance.

SERIAL # \_\_\_\_\_

MODEL # \_\_\_\_\_

(Be specific, include ALL letters and numbers)

COMPANY \_\_\_\_\_

ADDRESS \_\_\_\_\_

CITY \_\_\_\_\_

STATE, ZIP \_\_\_\_\_

PHONE # (\_\_\_\_\_) \_\_\_\_\_

CONTACT \_\_\_\_\_

Hours available for return call \_\_\_\_\_

Hardware Interface Type \_\_\_\_\_

Unit Interfaced with \_\_\_\_\_

Description of problem including actions taken just prior to problem occurring:

\_\_\_\_\_

\_\_\_\_\_

\_\_\_\_\_

\_\_\_\_\_

\_\_\_\_\_



# Table of Contents

<i>Introduction</i> .....	1
Hello! .....	1
Unpacking and Inspection.....	1
Reporting Damage .....	1
Storage .....	2
Media and Ribbon Requirements.....	2
Power Cord .....	3
Printer Anatomy 101 .....	4
<i>Calibrating the Printer</i> .....	5
Purpose.....	5
Types of Media .....	6
Non-Continuous Web Media.....	6
Continuous Media.....	7
Non-Continuous Black Mark Media .....	7
Choosing the Print Mode .....	8
Loading the Media .....	9
Positioning the Media Sensors.....	10
Transmissive Sensor .....	10
Black Mark Sensor .....	12
Loading the Ribbon.....	13
POWER Switch .....	14
Front Panel.....	14
Configuring the Printer .....	15
Configuring the Software or Printer Driver .....	16
Media and Ribbon Calibration.....	17
Printing a Test Label.....	19

<i>Establishing Communication</i> .....	<b>21</b>
System Considerations .....	21
Interfaces .....	21
Data Specifications .....	21
Cabling Requirements .....	22
<i>Printer Basics</i> .....	<b>23</b>
Operator Controls .....	23
POWER Switch .....	23
Front Panel Display .....	24
Front Panel Keys .....	25
Front Panel Lights .....	26
Roll Media Loading .....	27
Tear-Off Mode .....	27
Peel-Off Mode .....	28
Rewind Mode .....	30
Cutter Mode .....	32
Peel-Only Mode .....	33
Fanfold Media Loading .....	35
Removing the Label Backing Material .....	36
Ribbon Loading .....	37
Ribbon Removal .....	39
<i>Configuration</i> .....	<b>41</b>
Entering the Setup Mode .....	41
Changing Password-Protected Parameters .....	42
Leaving the Setup Mode .....	43
Configuration and Calibration Sequence .....	44
<i>Routine Care and Adjustment</i> .....	<b>63</b>
Cleaning .....	63
Cleaning the Exterior .....	64
Cleaning the Interior .....	64
Cleaning the Printhead and Platen Roller .....	64
Cleaning the Sensors .....	65
Cleaning the Snap Plate .....	66
Cleaning the Cutter Module .....	68



Lubrication .....	68
Fuse Replacement .....	68
Adjustments .....	69
Toggle Positioning .....	69
Printhead Pressure Adjustment.....	70
Media Sensor Position Adjustment .....	70
<b><i>Troubleshooting</i></b> .....	<b>71</b>
LED Error Conditions and Warnings .....	71
Print Quality Problems.....	74
Wrinkled Ribbon.....	75
Communications .....	75
Printer Diagnostics.....	77
Power-On Self Test.....	77
Additional Printer Self Tests .....	77
<b><i>Specifications</i></b> .....	<b>83</b>
Media Handling .....	83
Options .....	83
Zebra Programming Language (ZPL II®).....	84
Bar Codes.....	84
General Specifications .....	85
Printing Specifications .....	86
Ribbon Specifications .....	86
Font Specifications .....	87
Media Specifications.....	88
Power Line Cord Specifications .....	89
<b><i>BradyConnect License Agreement</i></b> .....	<b>93</b>
<b><i>Appendix A: DB9 Connectors</i></b> .....	<b>97</b>
Printer Interface Technical Information.....	97
RS-232 Serial Data Port.....	97
Parallel Data Port.....	102
<b><i>Appendix B: PCMCIA Card</i></b> .....	<b>103</b>
PCMCIA Card Installation .....	103
<b><i>Index</i></b> .....	<b>105</b>



# Introduction

## Hello!

This manual provides all of the information you need to operate your Bradyprinter 200M-e and 200M-e 300. In addition, the maintenance manual contains the information necessary to maintain your printer.

## Unpacking and Inspection

Carefully unpack and inspect the printer for possible damage incurred during shipment.

- Check all exterior surfaces.
- Raise the media access door and inspect the media compartment.

In case shipping is required, save the carton and all packing material. Contact your authorized Brady distributor for instructions.

### ***Reporting Damage***

If you discover shipping damage:

- Immediately notify the shipping company and file a report with them. *Brady Corporation is not responsible for any damage incurred during shipment of the equipment and will not repair this damage under warranty.*
- Keep the carton and all packing material for inspection.
- Notify your authorized Brady distributor.

## **Storage**

If you are not placing the printer into operation immediately, repackage it using the original packing materials. The printer may be stored under the following conditions:

- Temperature:  $-4^{\circ}$  to  $+140^{\circ}$  F ( $-20^{\circ}$  to  $+60^{\circ}$  C)
- Relative humidity: 5% to 85% non-condensing

## **Media and Ribbon Requirements**

Since print quality is affected by media and ribbon, printing speeds, and printer operating modes, it is very important to run tests for your applications.

We **STRONGLY RECOMMEND** the use of Brady-brand supplies for continuous high-quality printing. A wide range of paper, polypropylene, polyester, and vinyl stock has been specifically engineered to enhance the printing capabilities of the printer and to ensure against premature printhead wear.

- Continuous roll media, fanfold media, or card stock with optional perforations and registration holes may be used.
- Printhead life may be reduced by the abrasion of exposed paper fibers when using perforated media.
- The ribbon **MUST** be as wide as or wider than the media being used. If the ribbon is narrower than the media, areas of the printhead are unprotected and subject to premature wear. (When printing in direct thermal mode, ribbon is not used and should not be loaded in the printer.)

## Power Cord



**WARNING:** For personnel and equipment safety, always use a three-prong plug with a ground (earth) connection.

The power cord connector must be plugged into the mating connector on the rear of the printer.

Make sure that the POWER on/off switch (located at the back of the printer) is in the off position before connecting the power cable to an electrical outlet.

# Printer Anatomy 101

Figure 1 outlines the basic components of your printer. However, depending on the options you have selected, your printer may look slightly different.

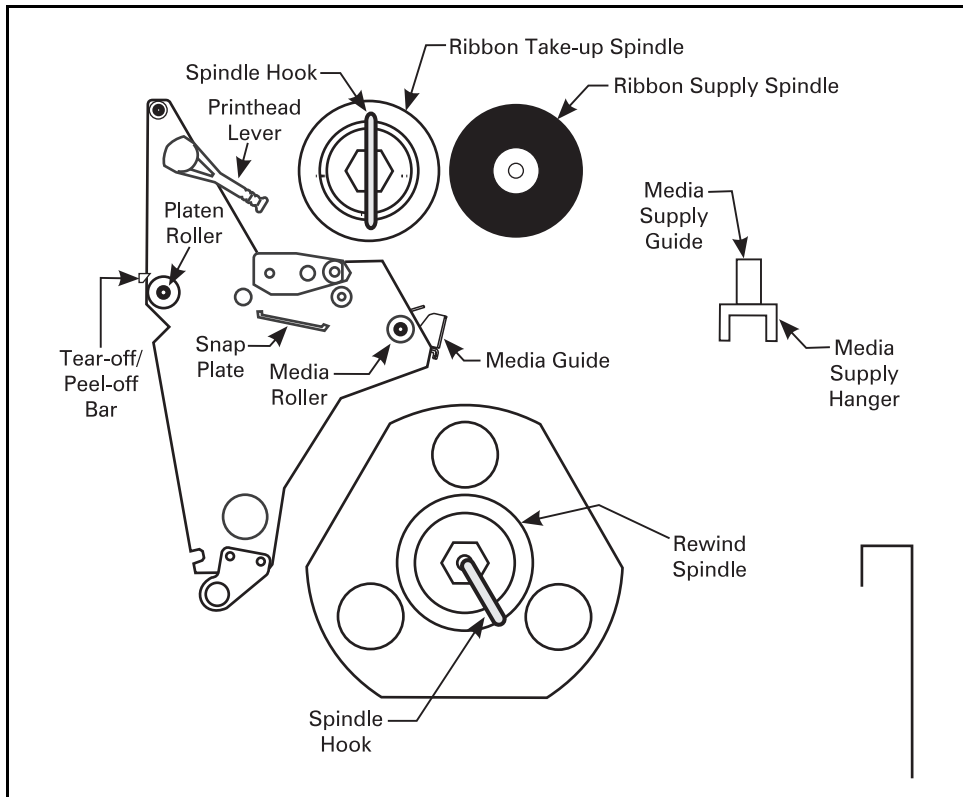

**Figure 1**

# Calibrating the Printer

This chapter of the user's guide is *so* important that we've printed it on a different color paper! That way, it will be easy for you to find when you must calibrate (set up) the printer for your particular application.

## Purpose

- To calibrate the printer.
- To verify that the printer is properly set up by printing a test label.



**NOTE:** This procedure *must* be performed when the printer is first installed or if it cannot properly detect the top of the label.

To calibrate the printer, perform the following procedures:

- Determine the **type of media** (labels) being used.
- Choose the **print method**.
- Position the **media sensors** (if necessary).
- **Configure the printer and software or driver** based on the label being used.
- Perform a **media and ribbon calibration**.
- Print a **test label**.

# Types of Media

## *Non-Continuous Web Media*

Non-continuous web media (refer to Figure 2) refers to individual labels that are separated by a gap, notch, or hole. When you look at the media, you can tell where one label ends and the next one begins.

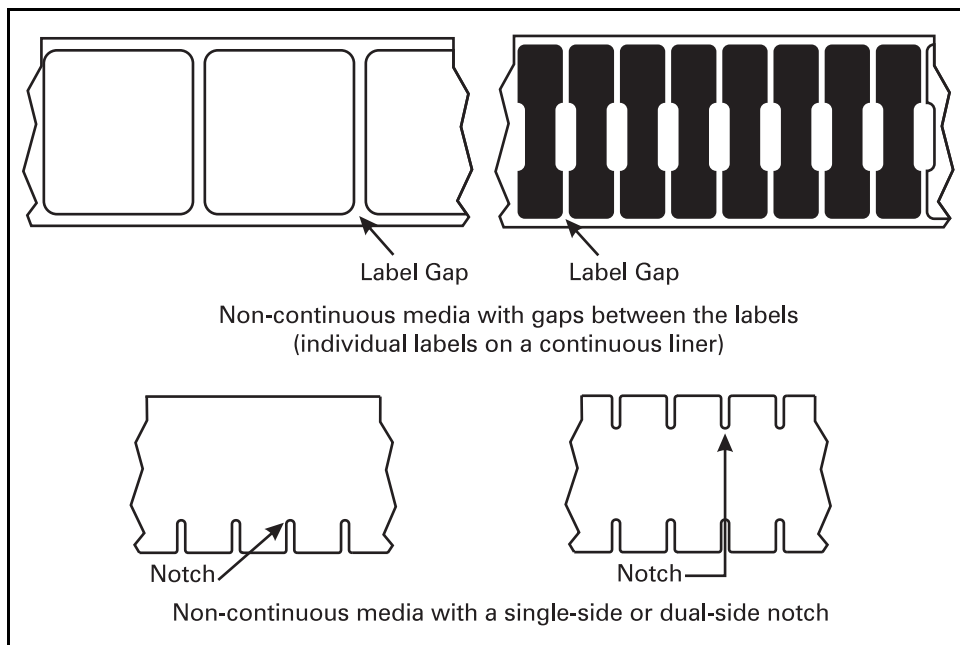
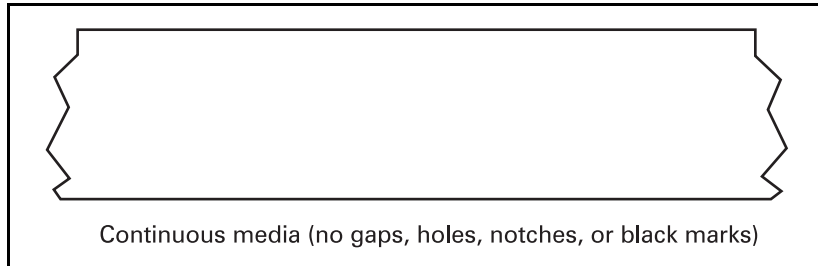

**Figure 2**



## ***Continuous Media***

Continuous media (refer to Figure 3) is one uninterrupted roll of material that allows the image to be printed anywhere on the label.



**Figure 3**

## ***Non-Continuous Black Mark Media***

Non-continuous black mark media has black marks printed on the back that indicate the start and end of each label (refer to Figure 4).

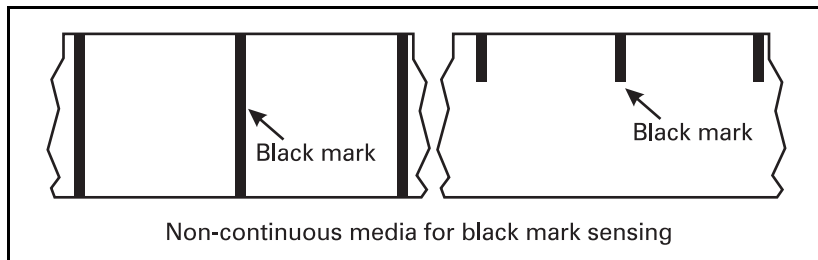

**Figure 4**

## Choosing the Print Mode

- In **Tear-Off** mode, each label (or a strip of labels) can be torn off after it is printed.
- In **Peel-Off** mode, backing material is peeled away from the label as it is printed. After this label is removed from the printer, the next one is printed.
- In **Cutter** mode, the printer automatically cuts the label after a specified number of labels has been printed.
- In **Rewind** mode, the media and backing are rewound onto a core as the labels are printed.

## Loading the Media

Figure 5 illustrates one method of media loading. For more detailed instructions, as well as information about how to load the different types of media and the various printing modes, refer to the instructions that begin on page 27.

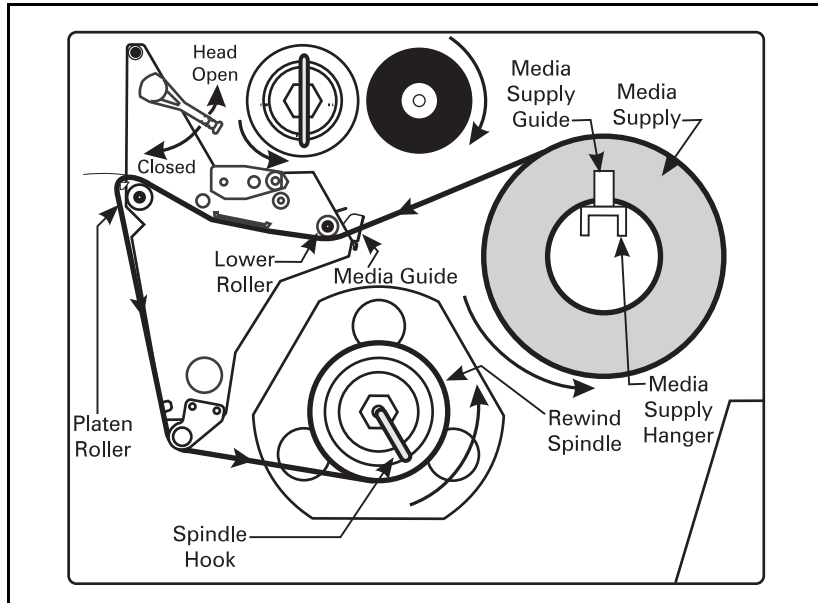

**Figure 5**

# Positioning the Media Sensors

The correct positioning of the media sensors is important — it can make the difference between a perfect label and a call to Technical Support!

## *Transmissive Sensor*

The web or gap sensor (transmissive sensor) detects the gap between labels.

The transmissive sensor actually consists of two sections: a light source (the lower media sensor) and a light sensor (the upper media sensor). The media passes between the two.

The upper media sensor must be positioned:

- Directly over the hole or notch, or
- Anywhere along the width of the media if there is a gap between labels.



**NOTE:** If you are using continuous media, position the upper media sensor over the media so that the printer can detect an out-of-paper condition.

## Adjusting the Upper Media Sensor

Refer to Figure 6. (For clarity, not all printer parts are shown.)

1. Remove the ribbon (if it is installed).
2. Locate the upper media sensor. The upper media sensor “eye” is directly below the adjustment screw head.
3. Slightly loosen the upper media sensor adjustment screw (use a Phillips-head screwdriver).
4. Using the tip of the screwdriver, slide the upper sensor along the slot to the desired position.
5. Secure the upper media sensor adjustment screw.

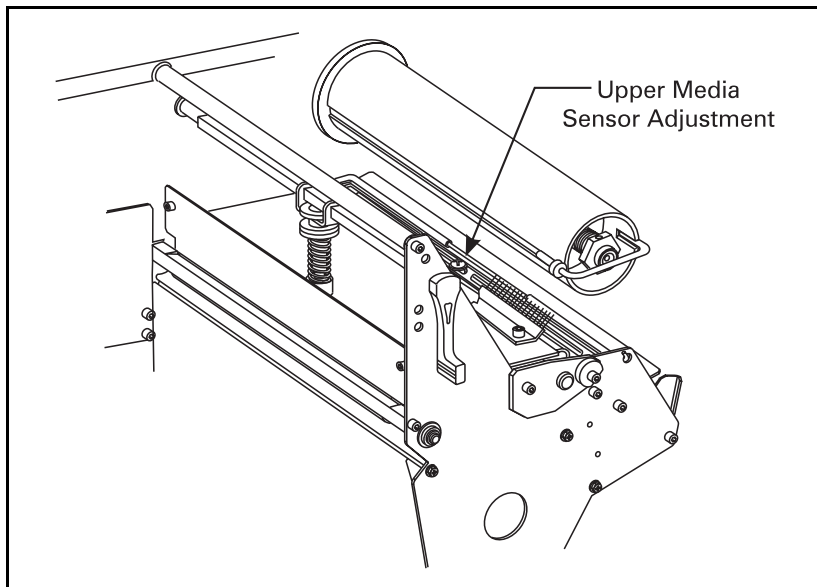

**Figure 6**

## Adjusting the Lower Media Sensor

Position the lower media sensor (refer to Figure 7) by sliding it in its slot until the lower media sensor is positioned under the upper media sensor.

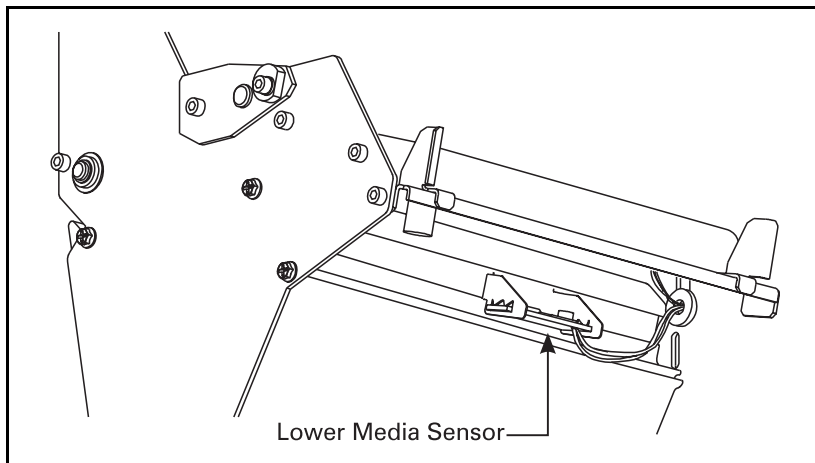

**Figure 7**

## ***Black Mark Sensor***

The black mark sensor is in a fixed position and enabled via the front panel (refer to “Configuring the Printer” on page 15 for details).

# Loading the Ribbon

To load the ribbon, refer to Figure 8. For more detailed information, refer to the instructions that begin on page 37.

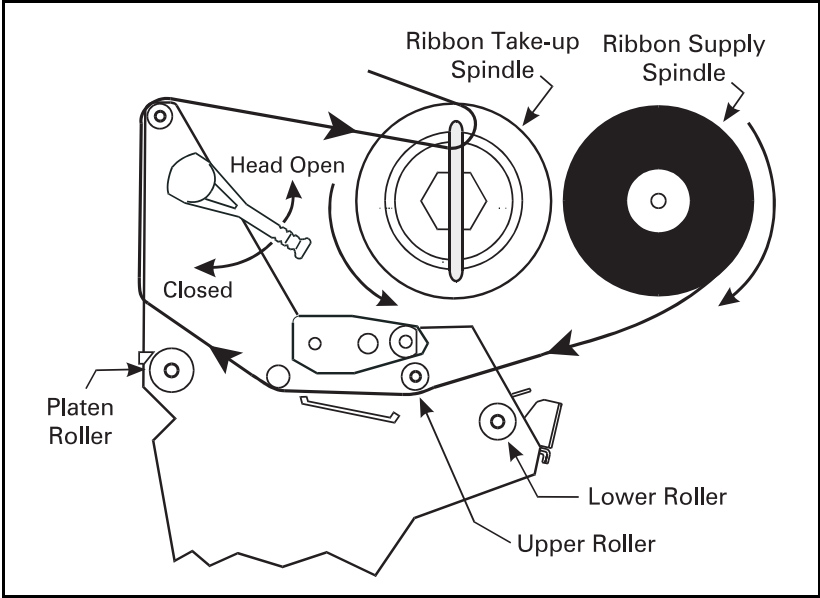

**Figure 8**

# Operator Controls

## POWER Switch

The POWER switch is located at the back of the printer above the power cord. Turn on the printer.

## Front Panel

The step-by-step instructions in this section tell you which keys to press and what appears on the liquid crystal display (LCD) during the calibration procedure.

For a more detailed explanation of the front panel keys and lights (as shown in Figure 9), refer to the instructions that begin on page 24.

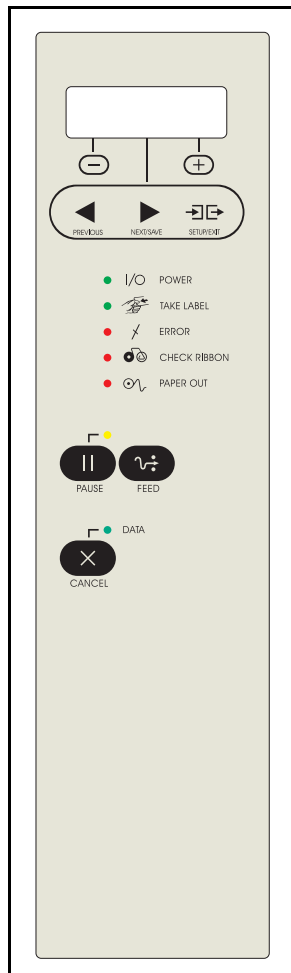

**Figure 9**



# Configuring the Printer

The configuration procedure in Table 1 contains the information you need to get your printer up and running, *but it is not comprehensive*. Refer to page 41 for more information.

- Enter the configuration mode by pressing the SETUP/EXIT key at the “PRINTER READY” display.



SETUP/EXIT



**NOTE:** You need to press the NEXT/SAVE key more than once to advance to some of the displays.









NEXT/SAVE

- To increase the value, answer “yes,” indicate “on,” or move to the next selection, use the (+) key.
- To decrease the value, answer “no,” indicate “off,” or return to the previous selection, use the (–) key.



**NOTE:** When changing parameters, an asterisk (\*) in the upper left-hand corner of the display indicates that you have changed this setting from the setting that is currently stored in memory.

**Table 1**

Press	Display Shows	Action/Explanation
—	PRINTER READY	Normal printer operation.
 SETUP/EXIT	DARKNESS	Press the (+) or (–) keys to increase or decrease the print darkness setting. (You <i>may</i> need to change this setting when you print your label.)
 NEXT/SAVE	PRINT MODE	Press the (+) or (–) keys to select tear-off, peel-off, cutter, or rewind mode.
 NEXT/SAVE	MEDIA TYPE	Press the (+) or (–) keys to select continuous or non-continuous media type. (If you choose continuous media, you must also include a label length instruction in your label format.)
 NEXT/SAVE	SENSOR TYPE	Press the (+) or (–) keys to select transmissive or black mark sensing mode. Unless your media has black marks on the back, leave your printer at the default setting (web).
 NEXT/SAVE	PRINT METHOD	Press the (+) or (–) keys to select thermal transfer (if you are using ribbon) or direct thermal (no ribbon).
 NEXT/SAVE	MAXIMUM LENGTH	Press the (+) or (–) keys to set the value that is closest to, but not less than, the length of the label you are using.
 SETUP/EXIT	SAVE SETTINGS	Press the (+) or (–) keys to select: PERMANENT — saves changes when the power is turned off. Press SETUP/EXIT to accept the selection.
—	PRINTER READY	You have exited the configuration mode and are now ready to calibrate the printer.

## Configuring the Software or Printer Driver

Many printer settings may also be controlled by your printer's driver or label preparation software. Please refer to the driver or software documentation for more information.

# Media and Ribbon Calibration



**NOTE:** All steps *must* be performed in the following procedure, even if only one sensor needs to be adjusted.

1. Press the SETUP/EXIT key.
2. Press the NEXT/SAVE key until “MEDIA AND RIBBON CALIBRATE” displays.
3. To start the calibration procedure, press the (+) key. “LOAD BACKING CANCEL CONTINUE” displays.
4. Open the printhead. Remove approximately 8" (203 mm) of labels from the media roll, enough so that only the backing material is threaded between the media sensors when the media is loaded (refer to Figure 10).

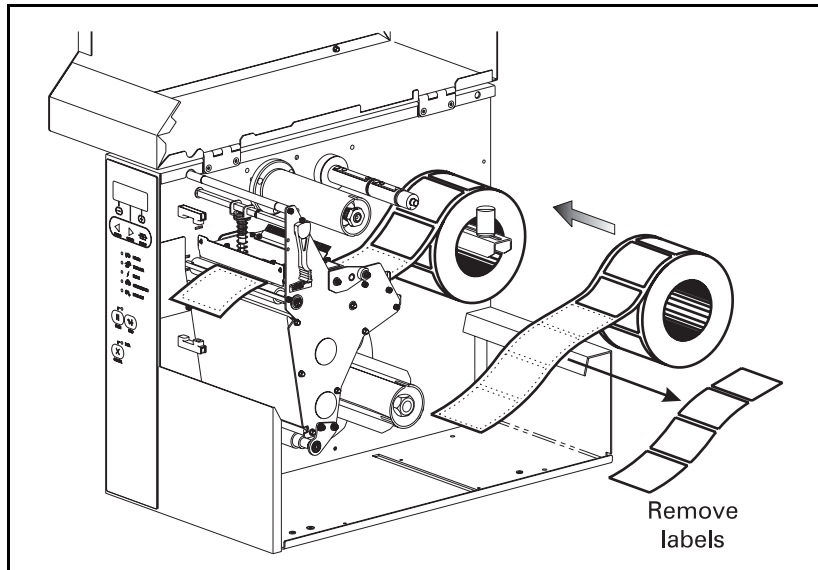

**Figure 10**

5. Press the (+) key. The front panel display shows “REMOVE RIBBON CANCEL CONTINUE.”
6. Either remove the ribbon or slide it as far from the printer frame as possible.
7. Close the printhead, trapping the ribbon in this position.
8. Press the (+) key. The front panel shows “CALIBRATING PLEASE WAIT.”
9. When this part of the calibration process is completed, the display reads “RELOAD ALL CONTINUE.”
10. Open the printhead. Pull the backing material until a label is positioned between the media sensors.
11. Either load the ribbon or return the ribbon to its proper position.
12. Close the printhead. Press the (+) key to perform the next part of the calibration sequence. “MEDIA AND RIBBON CALIBRATE” displays. The printer is calibrated when the media stops feeding.
13. Press the SETUP/EXIT key to leave the programming mode. Choose “permanent” when SAVE CHANGES displays.

# Printing a Test Label

To print a test label:

1. Turn off the printer.
2. Press and hold the CANCEL key while turning on the printer.

A configuration label showing the printer's currently stored parameters prints (similar to the one shown in Figure 11).

If you encounter any problems while you are configuring or calibrating the printer or printing a test label, refer to "Troubleshooting" beginning on page 71. Otherwise, refer to "Establishing Communication" beginning on page 21 to set up the communication parameters.

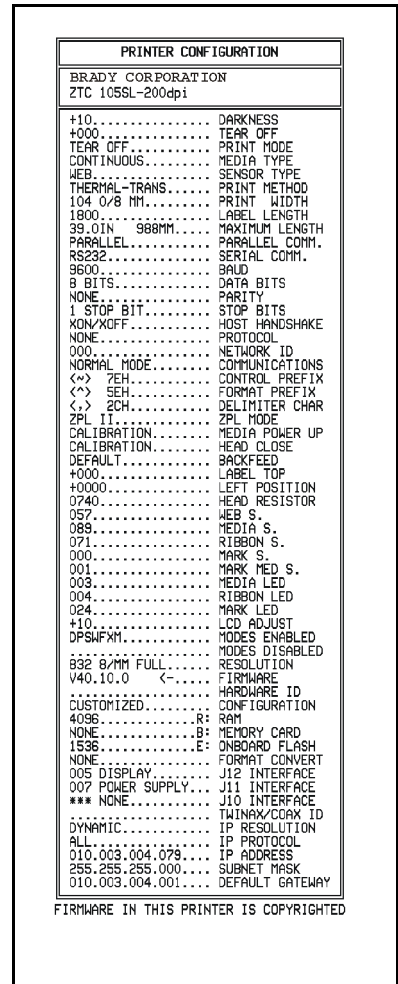



Figure 11



# Establishing Communication

## System Considerations

 **NOTE:** Your Brady 200M-e or 200M-e 300 printer is equipped with a DB9 serial connector.

## Interfaces

The method of interfacing this printer to a data source depends on the communication options installed in the printer. The standard interfaces are an RS-232 serial data port and a bi-directional parallel port. The optional ZebraNet PrintServer II enables printers to be connected to 10Base-T Ethernet networks. In addition, the IBM® Twinax or IBM Coax option is available for those applications that require them.

 **NOTE:** RS-422 and RS-485 serial data ports require an adapter for the DB9 serial interface connector. Contact Brady for details.

## Data Specifications

When communicating via an asynchronous serial data port (refer to Figure 12), the baud rate, number of data and stop bits, parity, and handshaking are user selectable. Parity only applies to data transmitted by the printer since the parity of received data is ignored.

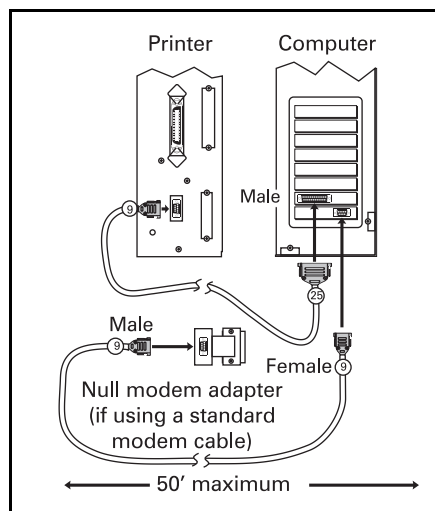

**Figure 12**

When communicating via the parallel port (refer to Figure 13), the previously mentioned parameters are not considered. Refer to page 52 to configure the communication parameters for the printer. The values selected must be the same as those used by the host equipment connected to the printer.

For serial and parallel pinout and technical information, refer to “Appendix A: DB9 Connectors” beginning on page 97.

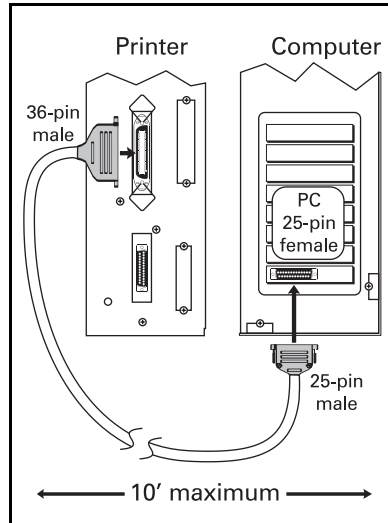

Figure 13

## Cabling Requirements

Data cables must be fully shielded and fitted with metal or metalized connector shells. Shielded cables and connectors are required to prevent radiation and reception of electrical noise.

To minimize electrical noise pickup in the cable:

- Keep data cables as short as possible.
- Do not bundle the data cables tightly with the power cords.
- Do not tie the data cables to power wire conduits.



**NOTE:** Brady printers comply with FCC “Rules and Regulations”, Part 15, Subpart J, for Class A Equipment, using fully shielded 6' data cables. Use of longer cables or unshielded cables may increase radiated emissions above the Class A limits.



**NOTE:** RS-422 and RS-485 applications should use twisted shielded pairs as recommended in the Appendix of the TIA/EIA.-485 Specification.



# *Printer Basics*

## **Operator Controls**

This section discusses the functions of the various controls and indicators on the printer. Become familiar with each of these functions before operating the printer.

### ***POWER Switch***

This switch is located at the back of the printer above the power cord. The POWER switch should be turned off before connecting or disconnecting any cables.

External influences, such as lightning storms or noise on the power or data cables, may cause erratic printer behavior. Turning the printer's power off and back on may re-establish proper printer operation.





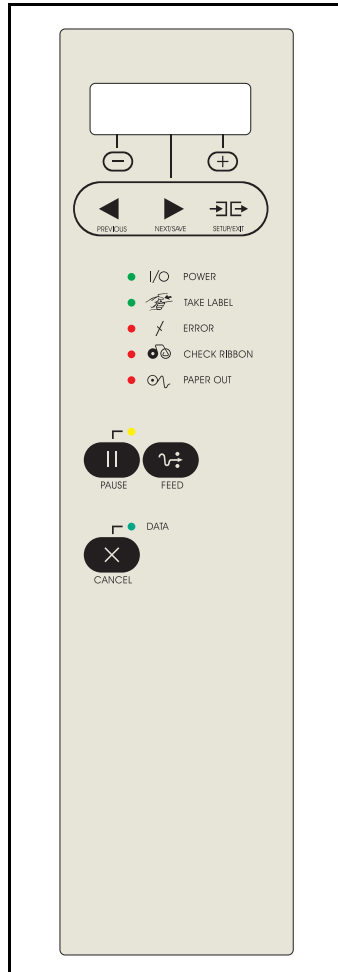



## Front Panel Display

The front panel display (as shown in Figure 14) communicates operational status and programming modes and parameters.



**Figure 14**







## Front Panel Keys

Key	Function
	<p>Starts and stops the printing process.</p> <ul style="list-style-type: none"> <li>• If the printer is not printing: no printing can occur.</li> <li>• If the printer is printing: printing stops once the current label is complete.</li> </ul> <p>Press to remove error messages from the display.  <b>NOTE:</b> Pause mode can also be activated via ZPL II (~PP, ^PP).</p>
	<p>Forces the printer to feed one blank label each time the key is pressed.</p> <ul style="list-style-type: none"> <li>• Printer not printing: one blank label immediately feeds.</li> <li>• Printing: one blank label feeds after the current batch of labels is complete.</li> </ul> <p><b>NOTE:</b> Equivalent to the Slew to Home Position (~PH, ^PH) ZPL II instruction.</p>
	<p>When in the pause mode, this key cancels print jobs.</p> <ul style="list-style-type: none"> <li>• Print job in queue: press once for each print job to be deleted.</li> <li>• Press and hold for several seconds to cancel all print jobs in the printer's memory. The DATA light turns off.</li> </ul>
<p><b>NOTE:</b> The keys below are used only when configuring the printer. Specific uses of these keys are explained in "Configuration" beginning on page 41.</p>	
	<ul style="list-style-type: none"> <li>• Scrolls back to the previous parameter.</li> <li>• Press <i>and hold</i> to quickly go backward through parameter sets.</li> </ul>
	<ul style="list-style-type: none"> <li>• Scrolls forward to the next parameter. (Saves any changes you've made in the configuration and calibration sequence.)</li> <li>• Press <i>and hold</i> to quickly advance through parameter sets.</li> </ul>
	<p>Enters and exits the configuration mode.</p>
	<p>These keys change the parameter values. They are used in different ways depending on the parameter displayed. Common uses are: to increase/decrease a value; answer "yes" or "no;" indicate "on" or "off;" scroll through several choices; input the password; or set up the printer for a firmware download.</p>
	

## Front Panel Lights



**NOTE:** If two operating conditions occur simultaneously (for example, one that causes a light to be on constantly and one that causes the same light to flash), the light flashes.

Light	Status	Indication
POWER 	Off	The printer is off or power is not applied.
	On	The printer is on.
TAKE LABEL 	Off	Normal operation.
	Flashing	(Peel-off mode only.) The label is available. Printing is paused until the label is removed.
ERROR 	Off	Normal operation — no printer errors.
	Flashing	A printer error exists. Check the display screen for more information.
CHECK RIBBON 	Off	Normal operation — ribbon (if used) is properly loaded.
	On	Printing is paused, the front panel displays a warning message, and the PAUSE light is on. <ul style="list-style-type: none"> <li>• If the printer is in direct thermal mode: Ribbon is loaded.</li> <li>• If the printer is in thermal transfer mode: No ribbon is loaded.</li> </ul>
PAPER OUT 	Off	Normal operation — media is properly loaded.
	On	No media is under the media sensor. Printing is paused, the display shows an error message, and the PAUSE light is on.
PAUSE 	Off	Normal operation.
	On	The printer has stopped all printing operations. Either the PAUSE key was pressed, a pause command was included in the label format, the on-line verifier detected an error, or a printer error was detected. Refer to the display screen for more information.
DATA	Off	Normal operation. No data being received or processed.
	On	Data processing or printing is taking place. No data is being received.
	Flashing	The printer is receiving data from <i>or</i> sending status information to the host computer. Flashing slows when the printer cannot accept more data, but returns to normal once data is again being received.

# Roll Media Loading



**NOTE:** A calibration must be performed when media and ribbon (if used) are first installed in the printer, or if a different type of media or ribbon is being used.

## ***Tear-Off Mode***

Refer to Figure 15.

1. Open the printhead.
2. Slide the media guide and media supply guide as far from the printer frame as possible.
3. Load media as shown.
4. Slide in the media guide and media supply guide so they just touch, but don't restrict, the edge of the roll.
5. Close the printhead.

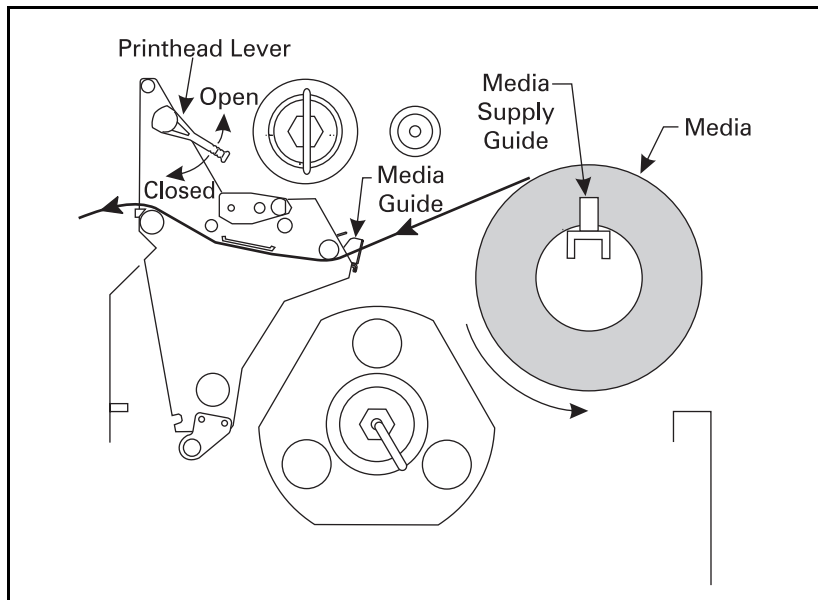

**Figure 15**

## ***Peel-Off Mode***

Refer to Figure 16.

1. Remove the rewind plate from the front of the printer (if installed). Store it on the two mounting screws on the inside of the front panel.
2. Open the printhead.
3. Slide the media guide and media supply guide as far from the printer frame as possible.
4. Load media as shown.
5. When loading media, allow approximately 36" (915 mm) of media to extend past the tear-off/peel-off bar. Remove all labels from this portion to create a leader.
6. Remove the hook from the rewind spindle. If you are using a core, slide it onto the rewind spindle until it is flush against the guide plate.
7. Wind the label backing around either the 3" (76 mm) core *or* the rewind spindle and reinstall the hook.
8. Slide in the media guide and media supply guide so they just touch, but don't restrict, the edge of the roll.

### **Before closing the printhead, make sure:**

- The media is positioned against the inside guides.
  - The media is taut and parallel with itself and the pathway when wound onto the rewind spindle/core.
9. Close the printhead.
  10. To discard the label backing from the rewind spindle, refer to "Removing the Label Backing Material" on page 36.

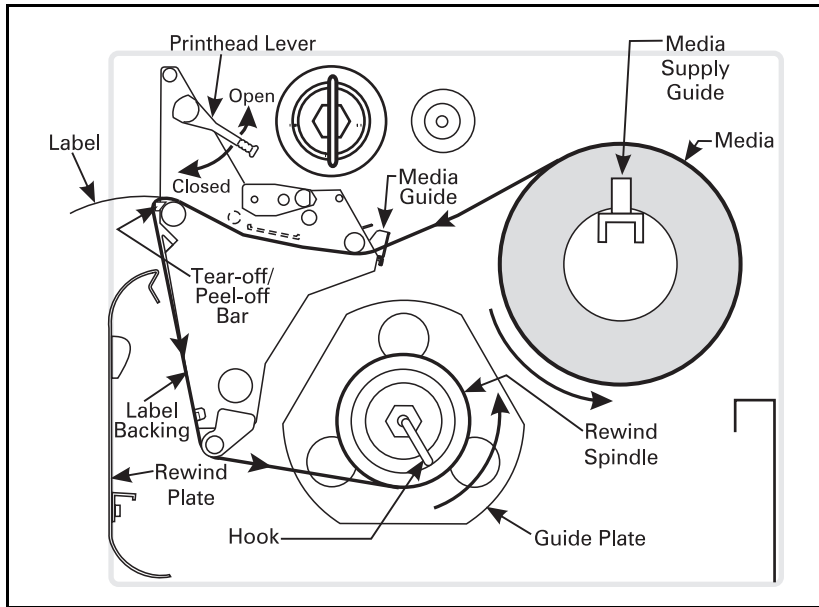

**Figure 16**

## ***Rewind Mode***

(Rewind option required)

Refer to Figure 17.

1. Remove the rewind plate from its storage location in front of the print mechanism inside the media compartment.
2. Invert the rewind plate so that the lip on the attached hook plate points down.
3. Insert the hook plate lip a short distance ( $\frac{1}{2}$ "/13 mm) into the lower opening in the side plate.
4. Align the upper end of the rewind plate with the corresponding opening in the side plate. Slide in the rewind plate so that it stops against the printer's main frame.
5. Open the printhead.
6. Slide the media guide and media supply guide as far from the printer frame as possible.
7. Load media as shown.
8. When loading media, allow approximately 36" (915 mm) of media to extend past the printhead. Remove all labels from this portion to create a leader.
9. Remove the hook from the rewind spindle. If you are using a core, slide it onto the rewind spindle until it is flush against the guide plate.
10. Wind the label backing around either the 3" (76 mm) core *or* the rewind spindle and reinstall the hook.
11. Slide in the media guide and media supply guide so they just touch, but don't restrict, the edge of the roll.



**Before closing the printhead, make sure:**

- The media is positioned against the inside guides.
- The media is taut and parallel with itself and the pathway when wound onto the rewind spindle/core.

12. Close the printhead.

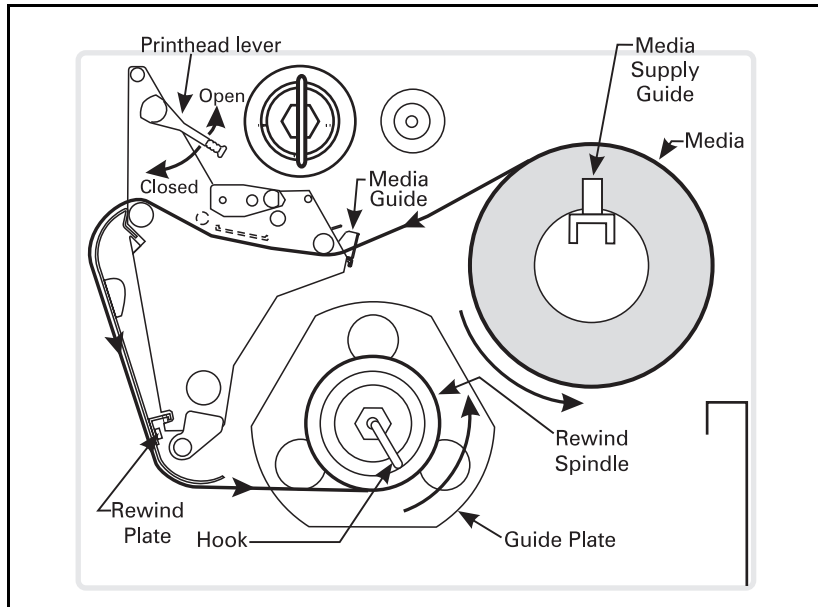

**Figure 17**

## Cutter Mode

(Cutter option required)

Refer to Figure 18.

1. Open the printhead.
2. Slide the media guide and media supply guide as far from the printer frame as possible.
3. Load media as shown.
4. Slide in the media guide and media supply guide so they just touch, but don't restrict, the edge of the roll.
5. Close the printhead.
6. The printer automatically feeds out and cuts one label when the printer is turned on.

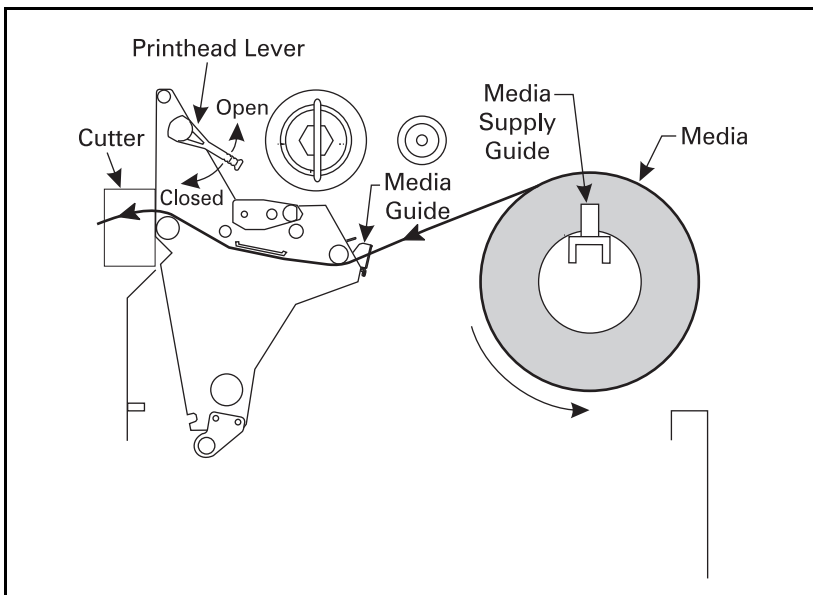

**Figure 18**

## ***Peel-Only Mode***

(Peel option required)

Refer to Figure 19.

1. Press the printhead open lever. The printhead assembly springs up.
2. Slide out the media supply guide as far from the printer frame as possible.
3. Place the roll of media on the media supply hanger.
4. Slide in the media supply guide so that it just touches, but does not restrict, the edge of the roll.
5. Feed the media under the inner media guide in the print mechanism.
6. Pull approximately 36" (915 mm) of media through the front of the printer.
7. Ensure that the media is against the inner media guide. Then, slide in the outer media guide so that it just touches, but does not restrict, the edge of the media.
8. Close the printhead assembly.
9. Remove the hook from the take-up spindle shaft.
10. Remove several labels from the media backing and then wind the backing 1-2 times around the media take-up spindle and reinstall the hook.



**NOTE:** If your printer has a *peel with a rewind* option, then you need to remove the rewind plate and store it on the mounting screw on the inside of the front panel before proceeding to step #9 above.

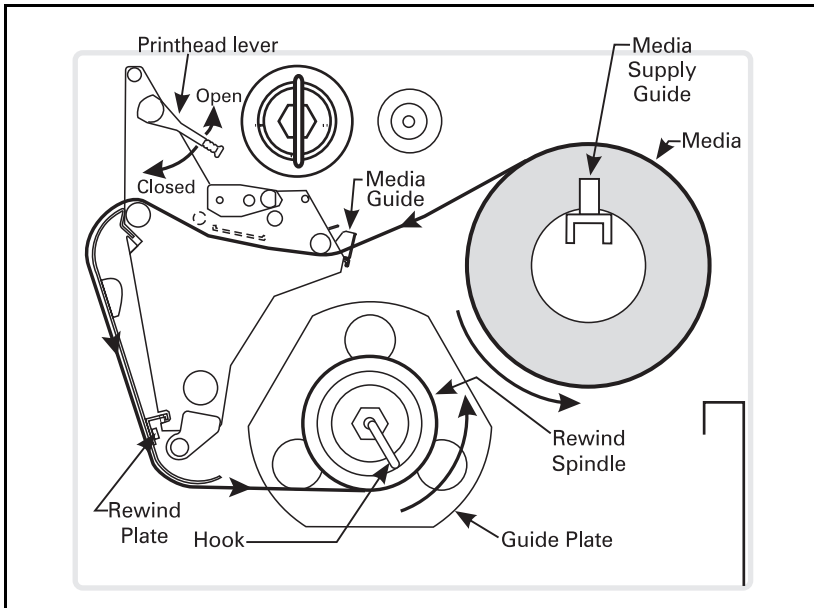

**Figure 19**

# Fanfold Media Loading



**NOTE:** A calibration must be performed when media and ribbon (if used) are first installed in the printer, or if a different type of media or ribbon is being used.

Fanfold media feeds through either the bottom or rear access slot from outside the printer.

Refer to Figure 20 and Figure 21.

1. Open the printhead.
2. Slide the media guide as far from the printer frame as possible.
3. Load media as shown. If in cutter mode, route media through the cutter.
4. Slide in the media guide so it just touches, but doesn't restrict, the edge of the roll.
5. Close the printhead.

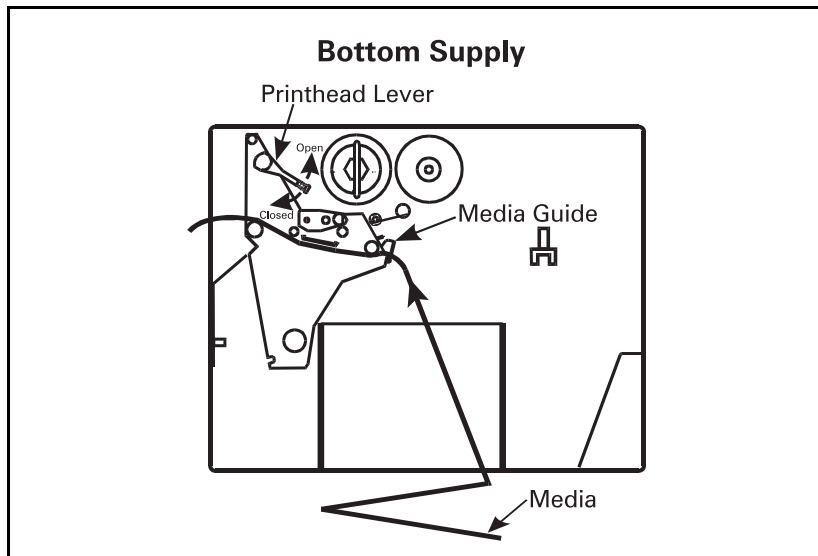

**Figure 20**

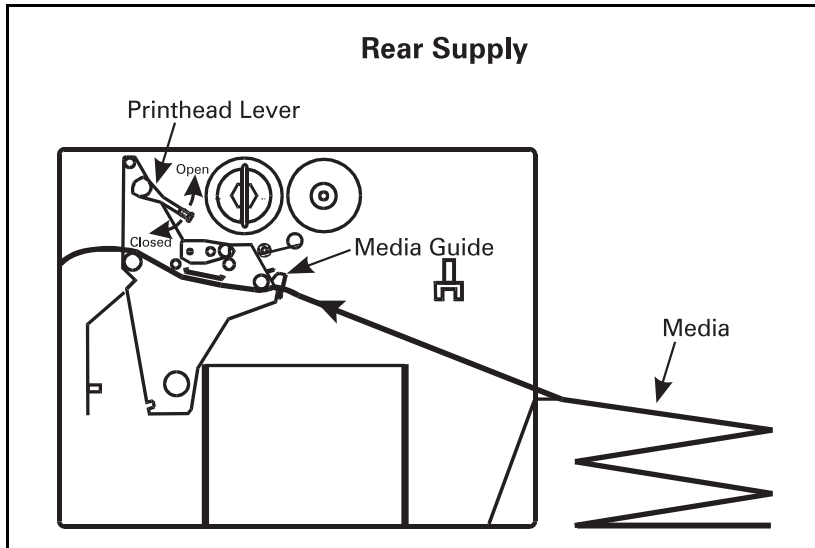

Figure 21

## Removing the Label Backing Material



**NOTE:** Since the rewind spindle holds the backing from a standard-size media roll, we recommend that you perform this procedure whenever you change the media.

To remove the backing material from the rewind spindle, follow these steps (you don't need to turn off the printer for this procedure).

1. Unwind approximately 36" (915 mm) of backing from the rewind spindle. Cut it off at the spindle.
2. Pull out the hook. Slide the backing material off of the rewind spindle and discard.
3. Wind the media around the rewind spindle once or twice and reinstall the hook. Continue winding to remove any slack in the media.

# Ribbon Loading

To load ribbon, refer to Figure 24 and follow the procedure below.



**NOTE:** Use ribbon that is at least as wide as the media. The smooth backing of the ribbon protects the printhead from wear and premature failure due to excessive abrasion. (*For direct thermal print mode, ribbon is not used and should not be loaded in the printer.*)

1. Align the segments of the ribbon supply spindle as shown in Figure 22.
2. Place the ribbon roll on the ribbon supply spindle.

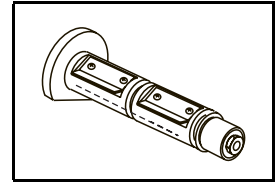
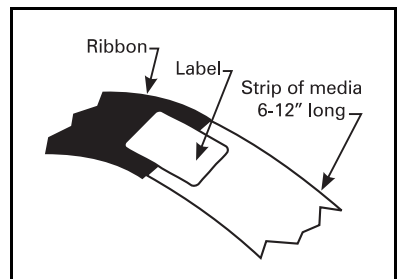

**Figure 22**



**NOTE:** Make sure that the core is pushed up against the stop on the ribbon supply spindle and that the ribbon is aligned squarely with its core. If this is not done, the ribbon may not cover the printhead entirely on the inside, exposing print elements to potentially damaging contact with the media.

3. Open the printhead.
4. To make ribbon loading and unloading easier, make a leader for your ribbon roll (see Figure 23).
5. Tear off a strip of media (labels and backing) about 6"-12" (152 mm-305 mm) long from the roll. Peel off a label from this strip. Apply half of this label to the end of the strip and the other half to the end of the ribbon. This acts as a ribbon leader.
6. Thread the ribbon (with leader) as shown without creasing or wrinkling it.
7. Place the ribbon (with leader) around the ribbon take-up spindle and wind counterclockwise for several turns (see Figure 24).



**Figure 23**

8. Close the printhead.

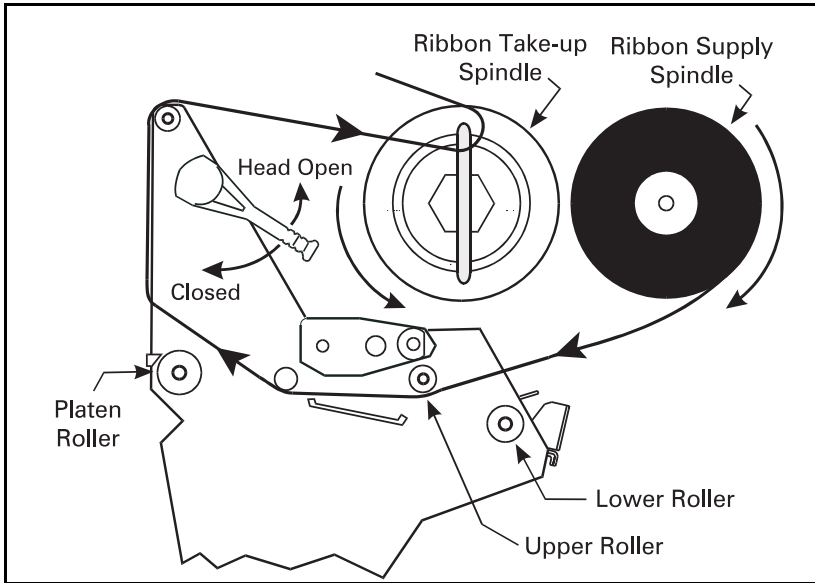

**Figure 24**



# Ribbon Removal

Refer to Figure 25.

1. Break the ribbon as close to the ribbon take-up spindle as possible.
2. Push the hook either forward or backward with your thumb until it slips out of the groove (1). Slide the hook to the side (2), then rotate it back and forth several times to loosen it (3).
3. Remove the loosened hook from the spindle (4).
4. Lightly tap the top of the used ribbon to loosen it; then grasp the used ribbon and remove it from the ribbon take-up spindle.
5. Remove the empty core from the ribbon supply spindle.
6. Follow the ribbon loading procedure on page 37 to load the new ribbon.

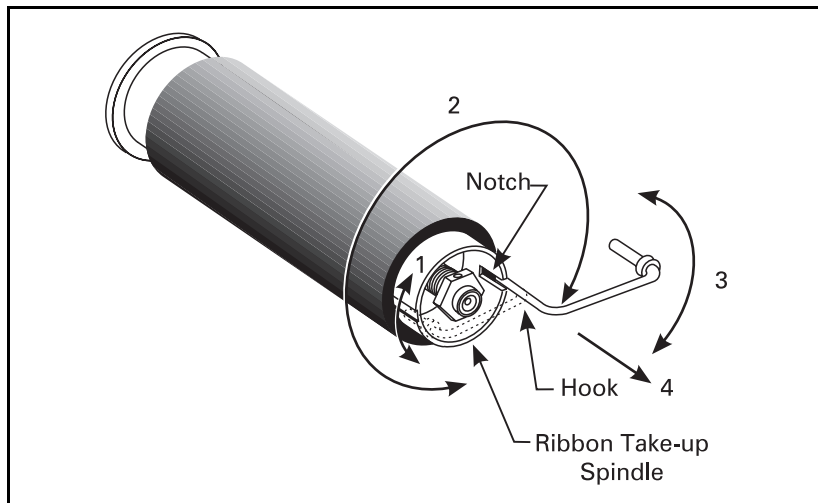

**Figure 25**



# Configuration

After you have installed the media and ribbon and the Power-On Self Test (POST) is complete, the front panel display shows “PRINTER READY.” (If the printer fails its POST, refer to page 77.) You may now set printer parameters for your application using the front panel display and the five keys directly below it.



**NOTE:** Printers that are operating on an IP network can be quickly configured via BradyConnect when the appropriate print server is used.

If it becomes necessary to restore the initial printer defaults, see “FEED Key and PAUSE Key Self Test” on page 81.



**NOTE:** Unless otherwise noted, all parameters are listed in the order they are displayed, starting with “DARKNESS.”

## Entering the Setup Mode

To enter the programming mode, press the SETUP/EXIT key. Press either the NEXT/SAVE key or PREVIOUS key to scroll to the parameter you wish to set.



**NOTE:** You may also press *and hold* the NEXT/SAVE and PREVIOUS keys to quickly advance through the configuration parameters.

Parameters in this section are shown in the order displayed when pressing the NEXT/SAVE key. Throughout this process, press the NEXT/SAVE key to continue to the next parameter, or press the PREVIOUS key to return to the previous parameter in the cycle.

An asterisk (\*) in the upper left-hand corner of the display indicates that the value displayed is different than the currently stored value.

## Changing Password-Protected Parameters

Certain parameters are password-protected by factory default.



**CAUTION:** Do not change password-protected parameters unless you are sure you know what you are doing! If the parameters are set incorrectly, they could cause the printer to function in an unpredictable way.

The first attempt to change one of these parameters (pressing either the (+) or (-) key) requires you to enter a four-digit password. This is done via the “ENTER PASSWORD” display. The (-) key changes the selected digit position; the (+) key increases the selected digit value. After entering the password, press the NEXT/SAVE key. The parameter you wish to change is displayed. If the password was entered correctly, you can now change the value.

The default password value is 1234. The password can be changed using the  $\wedge$ KP (Define Password) ZPL II instruction or through BradyConnect when the appropriate print server is used.



**NOTE:** Once the password has been entered correctly, it does not have to be entered again unless you leave and re-enter the programming mode using the SETUP/EXIT key.



**NOTE:** You can disable the password protection feature so that it no longer prompts you for a password by setting the password to  $\emptyset\emptyset\emptyset\emptyset$  via the  $\wedge$ KP $\emptyset$  ZPL/ZPL II command. To re-enable the password-protection feature, send the ZPL/ZPL II command  $\wedge$ KPx, where “x” can be any number, one to four digits in length, except  $\emptyset$ .

## Leaving the Setup Mode

You can leave the program mode at any time by pressing the SETUP/EXIT key. The “SAVE CHANGES” display appears. There are five choices, as described below. Pressing the (–) or (+) key displays other choices and pressing the NEXT/SAVE key selects the displayed choice.



- PERMANENT — Permanently saves the changes. Values are stored in the printer even when power is turned off.
- TEMPORARY — Saves the changes until you change them again or until power is turned off.
- CANCEL — Cancels all changes from the time you pressed the SETUP/EXIT key except the darkness and tear-off settings (if they were changed).
- LOAD DEFAULTS — Loads factory defaults. The factory defaults are shown on the following pages.







**NOTE:** Loading factory defaults requires printer calibration.

- LOAD LAST SAVE — Loads values from the last permanent save.







# Configuration and Calibration Sequence

Press	Display Shows	Action/Explanation
—	PRINTER READY	Normal printer operation.
<b>Setting Print Parameters</b>		
 SETUP/EXIT	DARKNESS	<p><b>Adjusting Print Darkness:</b> Press the (+) key to increase darkness. Press the (–) key to decrease darkness.  <b>Default:</b> +10  <b>Range:</b> 0 to +30</p> <p>Darkness settings are dependent upon a variety of factors including ribbon type, media, and the condition of the printhead. You may adjust the darkness for consistent high-quality printing. If printing is too light, or if there are voids in printed areas, you should increase the darkness. If printing is too dark, or if there is spreading or bleeding of printed areas, you should decrease the darkness.</p> <p>The FEED Key Self Test on page 80 can also be used to determine the best darkness setting. Since the darkness setting takes effect immediately, you can see the results on labels that are currently printing.</p> <p><b>CAUTION:</b> Set the darkness to the lowest setting that provides good print quality. Darkness set too high may cause ink smearing and/or it may burn through the ribbon.</p> <p>Darkness settings also may be changed by the driver or software settings.</p>
 NEXT/SAVE	TEAR OFF	<p><b>Adjusting the Tear-Off Position:</b> Press the (+) key to increase the value, press the (–) key to decrease the value. Each press of the key adjusts the tear-off position by four dot rows.  <b>Default:</b> +0  <b>Range:</b> –120 to +120</p> <p>This parameter establishes the position of the media over the tear-off/peel-off bar after printing. The label and backing can be torn off or cut between labels.</p>
 NEXT/SAVE	PRINT MODE	<p><b>Selecting Print Mode:</b> Press the (+) or (–) key to display other choices.  <b>Default:</b> Tear-off  <b>Selections:</b> Tear-off, peel-off, cutter, rewind</p> <p>Print mode settings tell the printer the method of media delivery that you wish to use. Be sure to select a print mode that your hardware configuration supports since some selections displayed are for optional printer features.</p>

Press	Display Shows	Action/Explanation
 NEXT/SAVE	MEDIA TYPE	<p><b>Setting Media Type:</b> Press the (+) or (-) key to display other choices.</p> <p><b>Default:</b> Continuous</p> <p><b>Selections:</b> Continuous, non-continuous</p> <p>This parameter tells the printer the type of media you are using. Selecting continuous media requires that you include a label length instruction in your label format (^Lxxxx if you are using ZPL or ZPL II).</p> <p>When non-continuous media is selected, the printer feeds media to calculate label length (the distance between two detections of the inter-label gap, webbing, or alignment notch or hole).</p>
 NEXT/SAVE	SENSOR TYPE	<p><b>Setting the Sensor Type:</b> Press the (+) or (-) key to display other choices.</p> <p><b>Default:</b> Web</p> <p><b>Selections:</b> Web, mark</p> <p>This parameter tells the printer whether you are using media with a web (gap/space between labels, notch, or hole) to indicate the separations between labels or if you are using media with a black mark printed on the back. If your media does not have black marks on the back, leave your printer at the default (web).</p>
 NEXT/SAVE	PRINT METHOD	<p><b>Selecting Print Method:</b> Press the (+) key for the next value; press the (-) key for the previous value.</p> <p><b>Default:</b> Thermal transfer</p> <p><b>Selections:</b> Thermal transfer, direct thermal</p> <p>The print method parameter tells the printer the method of printing you wish to use: direct thermal (no ribbon) or thermal transfer (using thermal transfer media and ribbon).</p> <p><b>NOTE:</b> Selecting direct thermal when using thermal transfer media and ribbon creates a warning condition, but printing continues.</p>

Press	Display Shows	Action/Explanation
	PRINT WIDTH	<p><b>Setting Print Width:</b> Press the (+) key to increase the value, press the (–) key to decrease the value. To change the unit of measurement, press the (–) key until the unit of measurement is active, then press the (+) key to toggle to a different unit of measure (inches, mm, or dots).</p> <p><b>Default; Range:</b> The default and range of acceptable values vary depending on what printer you have. Refer to “Printing Specifications” on page 86 for further information about the ranges available for your model.</p> <p>Print width determines the printable area across the width of the label.</p>
	MAXIMUM LENGTH	<p><b>Setting Maximum Length:</b> Press the (–) key to decrease the value, press the (+) key to increase the value.</p> <p><b>Default; Range:</b> The default and range of acceptable values vary depending on your printer’s configuration. Values are adjustable in 1" (25.4 mm) increments.</p> <p>Maximum length is used in conjunction with the calibration procedure. The value of this setting determines the maximum label length to be used during the media portion of the calibration process. Only a few labels are required to set media sensors. Always set the value that is closest to, but not lower than, the length of the label you are using. For example, if the length of the label is 14.5" (368 mm), set the parameter for 15.0" (381 mm).</p>



Listing Printer Information		
Press	Display Shows	Action/Explanation
 NEXT/SAVE	LIST FONTS	<p><b>List Fonts:</b> Press the (+) key to print a label listing all of the available fonts.</p> <p>This selection is used to print a label that lists all of the fonts currently available in the printer, including standard printer fonts plus any optional fonts. Fonts may be stored in RAM, FLASH memory, font EPROMs, or font cards.</p>
 NEXT/SAVE	LIST BAR CODES	<p><b>List Bar Codes:</b> Press the (+) key to print a label listing all of the available bar codes.</p> <p>This selection is used to print a label that lists all of the bar codes currently available in the printer.</p>
 NEXT/SAVE	LIST IMAGES	<p><b>List Images:</b> Press the (+) key to print a label listing all of the available images.</p> <p>This selection is used to print a label that lists all of the images currently stored in the printer's RAM, FLASH memory, optional EPROM, or optional memory card.</p>
 NEXT/SAVE	LIST FORMATS	<p><b>List Formats:</b> Press the (+) key to print a label listing all of the available formats.</p> <p>This selection is used to print a label that lists all of the formats currently stored in the printer's RAM, FLASH memory, optional EPROM, or optional memory card.</p>
 NEXT/SAVE	LIST SETUP	<p><b>List Setup:</b> Press the (+) key to print a label listing the current printer configuration.</p> <p>This selection is used to print a label that lists the current printer configuration information. (Same as CANCEL Key Self Test on page 78.)</p>
 NEXT/SAVE	LIST ALL	<p><b>List All:</b> Press the (+) key to print a label listing all of the available fonts, bar codes, images, formats, and the current printer configuration.</p> <p>This selection is used to print a label that lists the five previous selections, as described.</p>

Press	Display Shows	Action/Explanation
	<p>INITIALIZE CARD</p>	<p><b>Initialize Memory Card</b>  <b>CAUTION:</b> Perform this operation only when it is necessary to erase all previously stored information from the optional memory card (for printers with a PCMCIA slot). Press the NEXT/SAVE key to bypass this function.</p> <ol style="list-style-type: none"> <li>1. Press the (+) key to select “<b>YES.</b>”  If your printer is set to require a password, you are now prompted to enter the password. Enter the password and then press the NEXT/SAVE key.</li> <li>2. The display asks “INITIALIZE CARD?”. Press the (+) key “<b>YES.</b>”</li> <li>3. The front panel LCD asks “ARE YOU SURE?”.</li> <li>4. Press the (+) key “<b>YES</b>” to begin initialization.  <p style="text-align: center;"><b>or</b></p> Press the (–) key “<b>NO</b>” to cancel the request and return to the “INITIALIZE CARD” prompt.</li> <li>5. Press the SETUP/EXIT key followed by the NEXT/SAVE key.  If initialization is still in process, the front panel display flashes back and forth between the two phrases “CHECKING B: MEMORY” and “PRINTER IDLE.”  When initialization is complete, the printer automatically exits the configuration mode and the front panel displays “PRINTER READY.”</li> </ol> <p><b>NOTE:</b> Depending on the amount of memory in the memory card, initialization may take up to five minutes to complete.</p>

Press	Display Shows	Action/Explanation
	INIT FLASH MEM	<p><b>Initialize Flash Memory</b></p> <p><b>CAUTION:</b> Perform this operation only when it is necessary to erase all previously stored information from the FLASH memory. Press the NEXT/SAVE key to bypass this function.</p> <ol style="list-style-type: none"> <li>1. Press the (+) key to select <b>"YES."</b> If your printer is set to require a password, you are now prompted to enter the password. Enter the password and then press the NEXT/SAVE key.</li> <li>2. The display asks "INITIALIZE FLASH?". Press the (+) key <b>"YES."</b></li> <li>3. The front panel LCD asks "ARE YOU SURE?".</li> <li>4. Press the (+) key <b>"YES"</b> to begin initialization. <i>or</i> Press the (-) key <b>"NO"</b> to cancel the request and return to the "INITIALIZE FLASH" prompt.</li> <li>5. Press the SETUP/EXIT key followed by the NEXT/SAVE key. If initialization is still in process, the front panel display flashes back and forth between the two phrases "CHECKING E: MEMORY" and "PRINTER IDLE." When initialization is complete, the printer automatically exits the configuration mode and the front panel displays "PRINTER READY."</li> </ol> <p><b>NOTE:</b> Depending on the amount of free FLASH memory, initialization may take up to one minute to complete.</p>

**Media and Ribbon Sensor Calibration**

**NOTE:** Before you begin this procedure, make sure that the maximum length is set to a value equal to or greater than the length of the labels you are using. If the maximum length is set to a lower value, the calibration process assumes that continuous media is in the printer. See page 46 for more information.



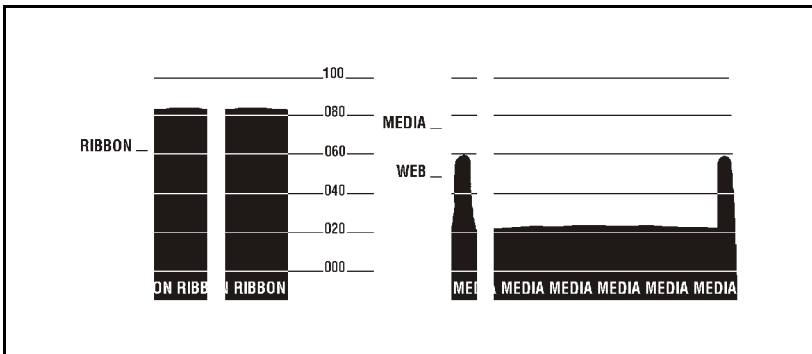

There are two different types of calibration that can be performed by the printer:

- 1) **Auto Calibration.** When the printer is first powered up and after the printhead has been closed, the printer feeds media and automatically sets the value it detects for media, media backing material (the spaces between labels), and media out. This type of calibration also occurs as part of the sensor profile and media and ribbon calibration procedures.
- 2) **Media and Ribbon Sensor Sensitivity Calibration.** Performing the media and ribbon calibration procedure first resets the sensitivity of the sensors to better detect the media and ribbon you are using. With the sensors at their new sensitivity, the printer then performs the auto calibration described above. Changing the type of ribbon and/or media may require resetting the sensitivity of the media and ribbon sensors. Indications that the sensitivity may need to be reset would be a CHECK RIBBON light on with the ribbon properly installed or non-continuous media being treated as continuous media.

Press	Display Shows	Action/Explanation
 NEXT/SAVE	SENSOR PROFILE	<p><b>Sensor Profile:</b> Press NEXT/SAVE to skip this standard calibration procedure and continue with the media and ribbon calibration parameter which follows. Press the (+) key to initiate this standard calibration procedure and print a media sensor profile. See Figure 26. The media sensor profile may be used to troubleshoot registration problems that may be caused when the media sensor detects preprinted areas on the media or experiences difficulty in determining web location. If the sensitivity of the media and/or ribbon sensors <b>MUST</b> be adjusted, use the media and ribbon sensor sensitivity procedure.</p>









**Figure 26**



Press	Display Shows	Action/Explanation
 NEXT/SAVE	MEDIA AND RIBBON CALIBRATE	<p><b>Media and Ribbon Sensor Sensitivity:</b> Press NEXT/SAVE to skip the calibration procedure and continue with the host port selection parameters that follow. Press the (+) key to start the calibration procedure.</p> <p>This procedure is used to adjust the sensitivity of the media and ribbon sensors.</p> <p><b>NOTE:</b> The procedure must be followed exactly as presented. All steps must be performed even if only one of the sensors requires adjustment.</p>
<b>Media and Ribbon Calibration Procedure</b>		
 NEXT/SAVE	LOAD BACKING	<ol style="list-style-type: none"> <li>1) Open the printhead.</li> <li>2) Remove approximately 8" (203 mm) of labels from the media roll, enough so that only the backing material is threaded between the media sensors when the media is loaded.</li> <li>3) Close the printhead.</li> </ol> <p><b>NOTE:</b> If you want to cancel the operation, press the (-) key.</p>
 NEXT/SAVE	REMOVE RIBBON	<ol style="list-style-type: none"> <li>1) Open the printhead.</li> <li>2) Remove the ribbon (sliding it as far to the right as possible has the same effect as removing it).</li> <li>3) Close the printhead.</li> </ol> <p><b>NOTE:</b> If you want to cancel the operation, press the (-) key.</p>
—	CALIBRATING PLEASE WAIT	The printer automatically adjusts the scale (gain) of the signals it receives from the media and ribbon sensors based on the specific media and ribbon combination you are using. On the sensor profile, this essentially corresponds to moving the graph up or down to optimize the readings for your application.
—	RELOAD ALL	<p>When "RELOAD ALL" is displayed:</p> <ol style="list-style-type: none"> <li>1) Open the printhead and pull the media forward until a label is positioned under the media sensor.</li> <li>2) Move the ribbon back to its proper position.</li> <li>3) Close the printhead.</li> </ol>
 NEXT/SAVE   SETUP/EXIT	MEDIA AND RIBBON CALIBRATE	Now that the scale has changed, the printer performs another calibration. During this process, the printer checks the readings for the media and ribbon based on the new scale you have established, determines the label length, and determines whether you are in direct thermal or thermal transfer print mode. The process is now complete! To see the new readings on the new scale, print a sensor profile.

### Setting Communication Parameters

Communication parameters must be set correctly for the printer to communicate with the host computer. These parameters make sure that the printer and host computer are “speaking the same language.” All communications parameters are password protected.

Press	Display Shows	Action/Explanation
 NEXT/SAVE	SERIAL COMM	<b>Setting Serial Communications:</b> Press the (+) or (–) key to display other choices. <b>Default:</b> RS-232 <b>Selections:</b> RS-232, RS-422/485, RS-485 multidrop Select the communications port that matches the one being used by the host computer.
 NEXT/SAVE	BAUD	<b>Setting Baud:</b> Press the (+) or (–) key to display other choices. <b>Default:</b> 9600 <b>Selections:</b> 110, 300, 600, 1200, 2400, 4800, 9600, 14400, 19200, 28800, 38400, 57600 The baud setting of the printer must match the baud setting of the host computer for accurate communications to take place. Select the value that matches the one being used by the host computer.
 NEXT/SAVE	DATA BITS	<b>Setting Data Bits:</b> Press the (+) or (–) key to display other choices. <b>Default:</b> 7-bits <b>Selections:</b> 7-bits, 8-bits The data bits of the printer must match the data bits of the host computer for accurate communications to take place. Set the data bits to match the setting being used by the host computer. <b>NOTE:</b> Must be set to 8 data bits to use Code Page 850.

Press	Display Shows	Action/Explanation
 NEXT/SAVE	PARITY	<p><b>Setting Parity:</b> Press the (+) or (-) key to display other choices.  <b>Default:</b> Even  <b>Selections:</b> Even, odd, none</p> <p>The parity of the printer must match the parity of the host computer for accurate communications to take place. Select the parity that matches the one being used by the host computer.</p>
 NEXT/SAVE	STOP BITS	<p><b>Setting Stop Bits:</b> Press the (+) or (-) key to display other choices.  <b>Default:</b> 1 stop bit  <b>Selections:</b> 1 stop bit, 2 stop bits</p> <p>The stop bits of the printer must match the stop bits of the host computer for accurate communications to take place. Select the stop bits that match the one being used by the host computer.</p>
 NEXT/SAVE	HOST HANDSHAKE	<p><b>Setting Host Handshake:</b> Press the (+) or (-) key to display other choices.  <b>Default:</b> XON/XOFF  <b>Selections:</b> XON/XOFF, DTR/DSR</p> <p>The handshake protocol of the printer must match the handshake protocol of the host computer for communications to take place. Select the handshake protocol that matches the one being used by the host computer.</p>
 NEXT/SAVE	PROTOCOL	<p><b>Setting Protocol:</b> Press the (+) or (-) key to display other choices.  <b>Default:</b> None  <b>Selections:</b> None, Zebra, ACK/NACK</p> <p>Protocol is a type of error checking system. Depending on the selection, an indicator may be sent from the printer to the host computer signifying that data has been received. Select the protocol that is requested by the host computer. For more details, contact Technical Support.</p> <p><b>NOTE:</b> "Zebra" is the same as ACK/NACK except that with "Zebra" the response messages are sequenced.</p> <p><b>NOTE:</b> If "Zebra" is selected, printer must use "DTR/DSR" host handshake protocol.</p>



Press	Display Shows	Action/Explanation
 NEXT/SAVE	NETWORK ID	<p><b>Setting Network ID:</b> Press the (-) key to move to the next digit position, press the (+) key to increase the value of the digit.  <b>Default:</b> 000  <b>Range:</b> 000 - 999</p> <p>Network ID is used to assign a unique number to a printer used in an RS-422/RS-485 network. This gives the host computer the means to address a specific printer. If the printer is used in a network, you must select a network ID number. This does not affect TCP/IP or IPX networks.</p>
 NEXT/SAVE	COMMUNICATIONS	<p><b>Setting Communications Mode:</b> Press the (+) or (-) key to display other choices.  <b>Default:</b> Normal mode  <b>Selections:</b> Normal mode, diagnostics</p> <p>The communication diagnostics mode is a troubleshooting tool for checking the interconnection between the printer and the host computer. When "diagnostics" is selected, all data sent from the host computer to the printer is printed as straight ASCII hex characters. The printer prints all characters received including control codes, like CR (carriage return). A sample printout is shown in Figure 34 on page 81.</p> <p><b>NOTES</b> on diagnostic printouts:</p> <ul style="list-style-type: none"> <li>• FE indicates a framing error.</li> <li>• OE indicates an overrun error.</li> <li>• PE indicates a parity error.</li> <li>• NE indicates noise.</li> </ul> <p>For any errors, check that your communication parameters are correct. Set the print width equal to or less than the label width used for the test. See page 46 for more information.</p>









### Selecting Prefix and Delimiter Characters

Prefix and delimiter characters are 2-digit hex values used within the ZPL/ZPL II formats sent to the printer. The printer uses the last prefix and delimiter characters sent to it, whether from a ZPL II instruction or from the front panel.









**NOTE:** DO NOT use the same hex value for the control, format, and delimiter character. The printer needs to see different characters to function properly.



Press	Display Shows	Action/Explanation
 NEXT/SAVE	CONTROL PREFIX	<b>Control Prefix Character:</b> Press the (-) key to move to the next digit position, press the (+) key to increase the value of the digit. <b>Default:</b> 7E (tilde - displayed as a black square) <b>Range:</b> 00 - FF The printer looks for this 2-digit hex character to indicate the start of a ZPL/ZPL II control instruction.
 NEXT/SAVE	FORMAT PREFIX	<b>Format Prefix Character:</b> Press the (-) key to move to the next digit position, press the (+) key to increase the value of the digit. <b>Default:</b> 5E (caret) <b>Range:</b> 00 - FF The printer looks for this 2-digit hex character to indicate the start of a ZPL/ZPL II format instruction.
 NEXT/SAVE	DELIMITER CHAR	<b>Delimiter Character:</b> Press the (-) key to move to the next digit position, press the (+) key to increase the value of the digit. <b>Default:</b> 2C (comma) <b>Range:</b> 00 - FF The delimiter character is a 2-digit hex value used as a parameter place marker in ZPL/ZPL II format instructions. For more details, contact Technical Support.





Selecting ZPL Mode		
Press	Display Shows	Action/Explanation
 NEXT/SAVE	ZPL MODE	<p><b>Selecting ZPL Mode:</b> Press the (+) or (-) key to display other choices.</p> <p><b>Default:</b> ZPL II</p> <p><b>Selections:</b> ZPL II, ZPL</p> <p>The printer remains in the selected mode until it is changed by this front panel instruction or by using a ZPL/ZPL II command. The printer accepts label formats written in either ZPL or ZPL II. This eliminates the need to rewrite any ZPL formats you already have. For more details, contact Technical Support.</p>
Power-Up and Head Close Parameters		
 NEXT/SAVE	MEDIA POWER UP	<p><b>Media Power-Up:</b> Press the (+) or (-) key to display other choices.</p> <p><b>Default:</b> Calibration</p> <p><b>Selections:</b> Feed, calibration, length, and no motion</p> <p>This parameter establishes the action of the media when the printer is turned on.</p> <ul style="list-style-type: none"> <li>• Calibration: Recalibrates the media and ribbon sensors.</li> <li>• Feed: Feeds the label to the first web.</li> <li>• Length: Determines the length of the label.</li> <li>• No Motion: Media does not move.</li> </ul>
 NEXT/SAVE	HEAD CLOSE	<p><b>Head Close:</b> Press the (+) or (-) key to display other choices.</p> <p><b>Default:</b> Calibration</p> <p><b>Selections:</b> Feed, calibration, length, no motion</p> <p>Determines the action of the media after the printhead has been opened and then closed.</p> <ul style="list-style-type: none"> <li>• Calibration: Recalibrates the media and ribbon sensors.</li> <li>• Feed: Feeds the label to the first web.</li> <li>• Length: Determines the length of the label.</li> <li>• No Motion: Media does not move.</li> </ul>

Label Positioning Parameters		
Press	Display Shows	Action/Explanation
 NEXT/SAVE	BACKFEED	<p><b>Backfeed Sequence:</b> Press the (+) or (-) key to display other choices.</p> <p><b>Default:</b> Default (90%)</p> <p><b>Selections:</b> Default, after, before, 10%, 20%, 30%, 40%, 50%, 60%, 70%, 80%, off</p> <p>This parameter establishes when and how much label backfeed occurs after a label is removed or cut in the peel-off, cutter, and applicator modes. It has no effect in rewind or tear-off modes. This parameter setting can be superseded by the ~JS instruction when received as part of a label format (for more details, contact Technical Support).</p> <p><b>NOTE:</b> The difference between the value entered and 100% establishes how much backfeed occurs before the next label is printed. For example, a value of 40 means that 40% of the backfeed takes place after the label is removed or cut. The remaining 60% takes place before the next label is printed. A value of "before" means that all backfeed takes place before the next label is printed.</p>
 NEXT/SAVE	LABEL TOP	<p><b>Adjusting Label Top Position:</b> Press the (+) key to increase the value, press the (-) key to decrease the value. The displayed value represents dots.</p> <p><b>Default:</b> +0</p> <p><b>Range:</b> -120 to +120 dot rows</p> <p>The label top position adjusts the print position vertically on the label. Positive numbers adjust the label top position further down the label (away from the printhead), negative numbers adjust the position up the label (toward the printhead).</p>
 NEXT/SAVE	LEFT POSITION	<p><b>Adjusting Left Position:</b> Press the (-) key to move to the next position, press the (+) key to change between + and - and to increase the value of the digit. The displayed value represents dots.</p> <p><b>Default:</b> 0000</p> <p><b>Range:</b> -9999 to +9999</p> <p><b>NOTE:</b> For a negative value, enter the value before changing to the minus sign.</p> <p>This parameter establishes how far from the left edge of a label the format begins to print by adjusting horizontal positioning on the label. Positive numbers adjust the printing to the left by the number of dots selected, negative numbers shift printing to the right.</p>





Press	Display Shows	Action/Explanation
	HEAD RESISTOR	<p><b>Setting the Head Resistor Value:</b> Press the (-) key to move to the next digit position, press the (+) key to increase the value of the digit.</p> <p><b>CAUTION:</b> This parameter should only be changed by qualified personnel!</p> <p><b>Initial Value:</b> Factory-set to match the printhead shipped with your printer.</p> <p><b>Default Value:</b> 0500</p> <p><b>Range:</b> 0500 to 1175</p> <p>This value has been pre-set at the factory to match the resistance value of the printhead. It does not need to be changed unless the printhead is replaced.</p> <p><b>CAUTION:</b> DO NOT set the value higher than that shown on the printhead. Setting a higher value may damage the printhead!</p> <p>Before replacing a printhead, look on the bottom of the printhead element for the label that shows the resistance value (ohm value).</p>

Press	Display Shows	Action/Explanation
 NEXT/SAVE	WEB S.	<p>These parameters are automatically set during the calibration procedure. They should only be changed by a qualified service technician. Refer to the maintenance manual for more information on these parameters.</p> <p>Press the NEXT/SAVE key repeatedly to skip these parameters.</p>
 NEXT/SAVE	MEDIA S.	
 NEXT/SAVE	RIBBON S.	
 NEXT/SAVE	MARK S.	
 NEXT/SAVE	MARK MED S.	
 NEXT/SAVE	MEDIA LED	
 NEXT/SAVE	RIBBON LED	
 NEXT/SAVE	MARK LED	

Press	Display Shows	Action/Explanation
 NEXT/SAVE	LCD ADJUST	<p><b>LCD Display Adjustment:</b> Press the (-) key to decrease the value (reduce brightness), press the (+) key to increase the value (increase brightness).</p> <p><b>Range:</b> 00 to 19</p> <p>This parameter allows you to adjust the brightness of your display if it is difficult to read.</p>
 NEXT/SAVE	FORMAT CONVERT	<p><b>Format Convert:</b> Press the (+) or (-) key to display other choices.</p> <p><b>Default:</b> None</p> <p><b>Selections:</b> None, 150 → 300, 150 → 600, 200 → 600, 300 → 600</p> <p>Selects the bitmap scaling factor. The first number is the original dots per inch (dpi) value; the second, the dpi to which you would like to scale.</p>

Press	Display Shows	Action/Explanation
 NEXT/SAVE	IP RESOLUTION*	<b>IP Resolution:</b> Press the (+) or (-) key to display other choices. <b>Default:</b> Dynamic <b>Selections:</b> Dynamic, permanent Depending on the selection, allows either the user ("permanent") or the server ("dynamic") to select the IP address. For more information, contact Technical Support.
 NEXT/SAVE	IP PROTOCOLS*	<b>IP Protocols:</b> Press the (+) or (-) key to display other choices. <b>Default:</b> All <b>Selections:</b> All, gleaning only, RARP, BOOTP, DHCP, DHCP/BOOTP If "dynamic" was chosen in the previous parameter, this selection determines the method(s) by which the PrintServer II receives the IP address from the server. For more information, contact Technical Support.
 NEXT/SAVE	IP ADDRESS*	<b>IP Address:</b> Press the (-) key to move to the next digit position, press the (+) key to increase the value of the digit. This parameter allows you to select the IP address <i>if</i> "permanent" was chosen in "IP RESOLUTION." (If "dynamic" was chosen, the user cannot select the address.) For more information, contact Technical Support.
 NEXT/SAVE	SUBNET MASK*	<b>Subnet Mask:</b> Press the (+) or (-) key to display other choices. <b>Default:</b> Permanent (user <i>must</i> set) <b>Selections:</b> Dynamic (user <i>may</i> set, but server can assign), permanent This parameter selects the part of the IP address that is considered to be part of the local network. It can be reached without going through the default gateway.
 NEXT/SAVE	DEFAULT GATEWAY*	<b>Default Gateway:</b> Press the (-) key to move to the next digit position, press the (+) key to increase the value of the digit. This parameter allows you to select the IP address that the network traffic is routed through if the destination address is not part of the local network.

\* Optional equipment required — contact Technical Support for details.

Press	Display Shows	Action/Explanation
 NEXT/SAVE	LANGUAGE	<p><b>Selecting the Display Language:</b> Press the (+) or (-) key to display other choices.</p> <p><b>Default:</b> English</p> <p><b>Selections:</b> English, Spanish, French, German, Italian, Norwegian, Portuguese, Swedish, Danish, Spanish 2, Dutch, Finnish, Japanese</p> <p>This parameter allows you to change the language used on the front panel display.</p>
You have now completed the entire configuration and calibration sequence. You may either press the NEXT/SAVE key or the SETUP/EXIT key.		
 NEXT/SAVE	DARKNESS	<p>You are now back at the first parameter in the configuration sequence.</p> <p><b>NOTE:</b> If you pressed the NEXT/SAVE key but are through programming the printer configuration, you may press the SETUP/EXIT key and continue with the "SAVE SETTINGS" function.</p>
 SETUP/EXIT	SAVE SETTINGS	<p><b>Save Settings:</b> Press the (+) or (-) key to display other choices.</p> <p><b>Default:</b> Permanent</p> <p><b>Selections:</b> Permanent, temporary, cancel, load defaults, load last save</p> <p>This display appears when you attempt to exit the configuration mode.</p> <ul style="list-style-type: none"> <li>• Permanent: Permanently saves the changes, even when printer power is turned off.</li> <li>• Temporary: Saves the changes until changed again or until power is turned off.</li> <li>• Cancel: Cancels all changes since you entered the configuration mode except for darkness and tear-off position (if they were changed).</li> <li>• Load defaults: Loads factory defaults.</li> </ul> <p><b>NOTE:</b> Loading factory defaults requires calibration.</p> <ul style="list-style-type: none"> <li>• Load last save: Loads the values from the last permanent save.</li> </ul>
 NEXT/SAVE	PRINTER READY	<p>Press the NEXT/SAVE key to activate the displayed choice. You have exited the configuration and calibration sequence and are now ready for normal printer operation.</p>



# Routine Care and Adjustment

## Cleaning

Table 2 provides a brief cleaning schedule. Specific cleaning procedures are provided on the following pages.

**Table 2**

Area	Method	Interval
Printhead	Solvent*	<b>Direct thermal print mode:</b> After every roll of media (or 500'/152 m of fanfold media).
Platen roller	Solvent*	
Transmissive sensor	Air blow	
Black mark sensor	Air blow	
Media path	Solvent*	<b>Thermal transfer print mode:</b> After every roll of ribbon.
Ribbon sensor	Air blow	
Label available sensors	Air blow	Monthly
Tear-off/peel-off bar	Solvent*	As needed
Snap plate	Solvent*	
Cutter	Solvent*	

\* Brady recommends using a solvent containing 90% isopropyl alcohol.



**CAUTION:** Use only the cleaning agents indicated. Brady Corporation will not be responsible for any other fluids being used on this printer.

## ***Cleaning the Exterior***

The exterior surfaces of the printer may be cleaned with a lint-free cloth. Do not use harsh or abrasive cleaning agents or solvents. If necessary, a mild detergent solution or desktop cleaner may be used sparingly.

## ***Cleaning the Interior***

Inspect this area after every four rolls of media. Remove any dirt and lint from the interior of the printer using a soft bristle brush and/or vacuum cleaner.

## ***Cleaning the Printhead and Platen Roller***

Inconsistent print quality, such as voids in the bar code or graphics, may indicate a dirty printhead. For best results, perform the following cleaning procedure after every roll of ribbon.



**NOTE:** You do not need to turn off the printer before cleaning the printhead. If power is turned off, all label formats and images, as well as any temporarily saved parameter settings stored in the printer's internal memory, are lost. When power is turned back on, these items need to be reloaded.

To clean the printhead, refer to Figure 27 and follow these steps:

1. Open the printhead.
2. Remove the media and ribbon (if loaded).
3. Moisten an applicator tip with solvent and wipe along the print elements from end to end. (The print elements are on the brown strip just behind the chrome strip on the printhead.) Allow a few seconds for the solvent to evaporate.
4. Rotate the platen roller and clean thoroughly with solvent and an applicator.
5. Brush/vacuum any accumulated paper lint and dust away from the rollers.
6. Reload ribbon and/or media, and close the printhead.

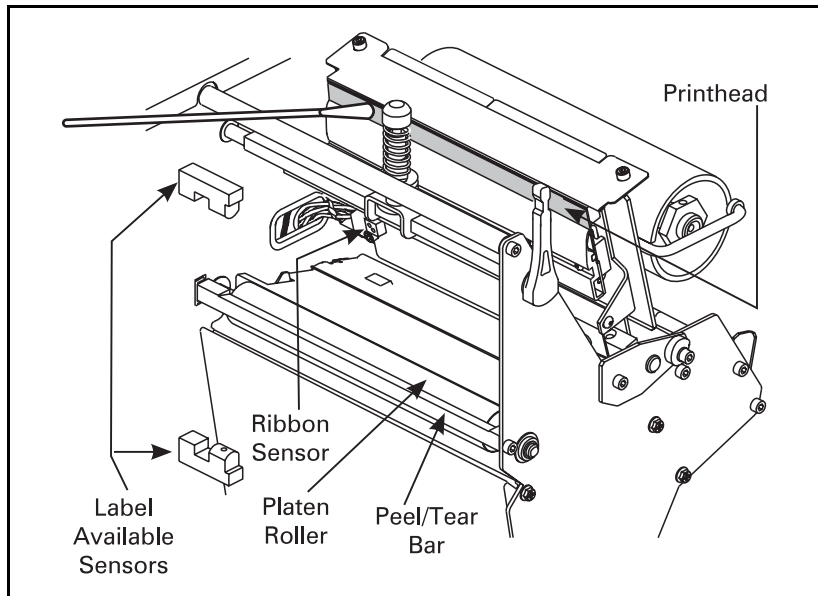

**Figure 27**

### ***Cleaning the Sensors***

The media, ribbon, and label available sensors should be cleaned on a regular basis to ensure proper operation of the printer. To locate these sensors, refer to Figure 27, Figure 6 on page 11, and Figure 7 on page 12. Brush/vacuum any accumulated paper lint and dust off of these sensors.

## Cleaning the Snap Plate

Clean the snap plate to remove label adhesive or a label that has adhered to the underside of the snap plate.

Refer to Figure 28.

1. Insert a small-blade screwdriver or similar tool into the loop on the left side of the snap plate. Lift the snap plate.



**CAUTION:** Take care not to bend, twist, or otherwise deform the loops!

2. Repeat step one on the right side of the snap plate.
3. Remove the snap plate from the printer.
4. Clean the snap plate with cleaning solvent and a soft cloth.

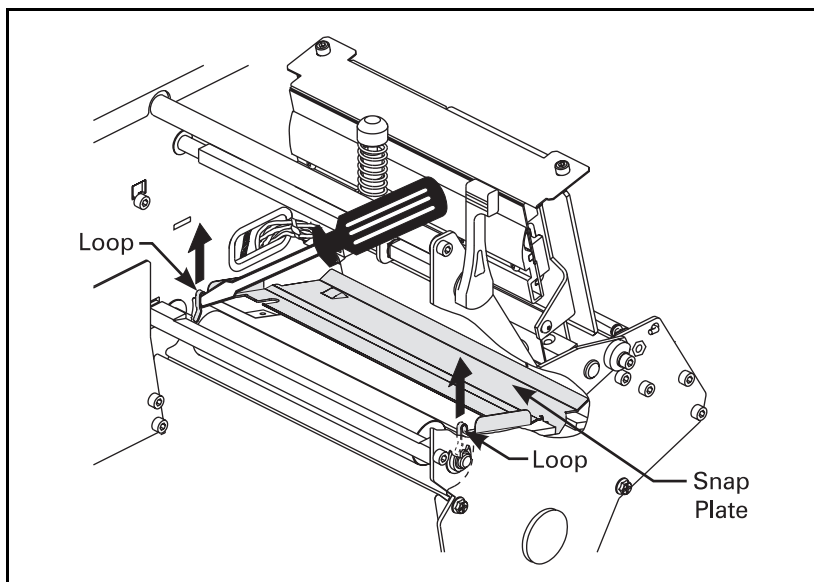

**Figure 28**

Refer to Figure 29.

5. To reinstall the snap plate, insert the two tabs on the bottom of the snap plate into the two slots of the media pathway.
6. Slide the snap plate toward you.
7. Press down on the loops to lock the snap plate into place.

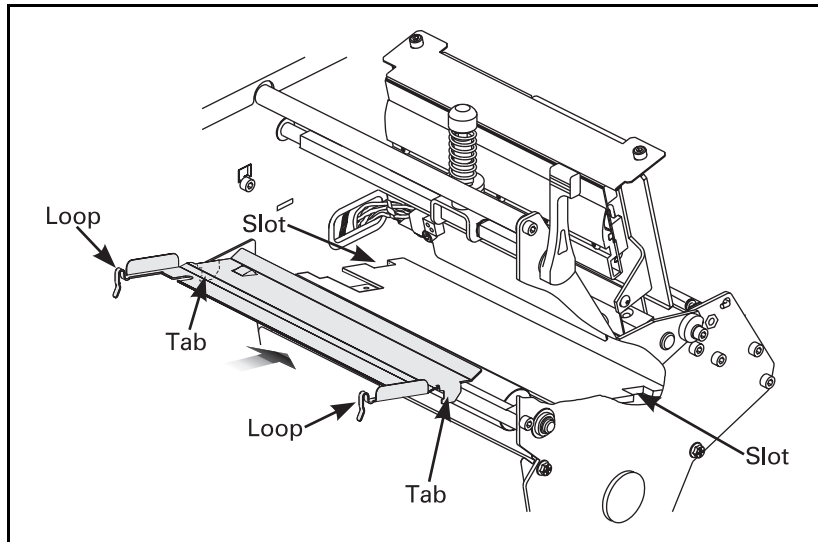

**Figure 29**

## ***Cleaning the Cutter Module***

(For printers equipped with the optional cutter.)

If labels are not being cut properly or if the cutter jams with labels, turn off the printer power and unplug the printer. Then, clean the stationary cutter blade with cleaning solvent. This removes label adhesive and/or paper debris. If further cutter cleaning is necessary, or if the cutter continues to perform unsatisfactorily, contact an authorized service technician.



**WARNING:** Turning off the printer results in the loss of label formats, images, and any temporarily saved parameter settings stored in the printer's internal memory. Perform this procedure after your printing job is complete!

## **Lubrication**



**CAUTION:** No lubricating agents other than silicon-only lubricants should be used on the spindle felt clutches of this printer! Other commercially available lubricants will damage the finish and mechanical parts if used.

## **Fuse Replacement**

The fuse in the Brady 200M-e and 200M-e 300 printers is not user replaceable and must be replaced by a qualified service technician. Contact Brady for details.

# Adjustments

## *Toggle Positioning*

The toggle should be positioned so that it provides even pressure on the media. Position the toggle by sliding it to the desired location (see Figure 30).

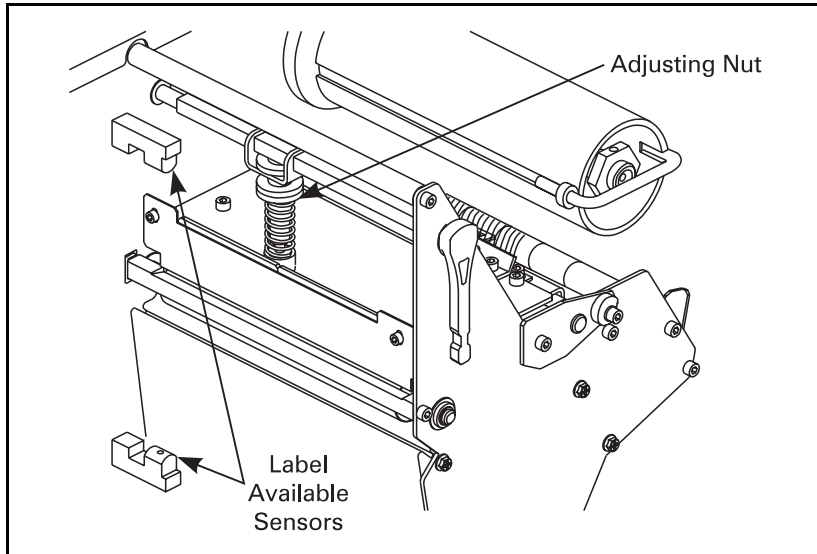

**Figure 30**

## ***Printhead Pressure Adjustment***

This adjustment may be necessary if printing is too light on one side or if thick media is used. Refer to Figure 30.

1. Perform the toggle positioning procedure. If the problem is solved, you may stop here; otherwise, continue with the rest of this procedure.
2. Print some labels at 2.4"/61 mm per second by running the PAUSE Key Self Test (see page 79).
3. While printing labels, lower the darkness setting until a gray level of printing is seen.
4. Loosen the knurled (upper) locking nuts at the top of the toggle assembly/assemblies.
5. Increase or decrease spring pressure using the knurled (lower) adjusting nuts on the shafts of the toggle until the left and right edges of printed area are equally dark.



**NOTE:** Printhead life can be maximized by using the lowest pressure that produces the desired print quality.

6. Increase darkness to the optimum level for the media being used.
7. Retighten locking nuts.

## ***Media Sensor Position Adjustment***

See “Positioning the Media Sensors” on page 10.



# Troubleshooting

## LED Error Conditions and Warnings

### Error Condition — Ribbon Out

Problem	Solution
In thermal transfer mode, the ribbon is not loaded <i>or</i> loaded incorrectly.	Load the ribbon correctly. See “Ribbon Loading” on page 37.
In thermal transfer mode, the ribbon sensor is not sensing correctly loaded ribbon.	Perform the media and ribbon sensor calibration (see page 17).
In direct thermal mode, when ribbon is not used:	Put the printer in direct thermal mode via the front panel and remove ribbon (if loaded).
	Ensure that the printer driver or software settings are correctly set (if applicable).

### Error Condition — Paper Out

Problem	Solution
The media is not loaded <i>or</i> loaded incorrectly.	Reload the media. Refer to “Roll Media Loading” on page 27.
The media sensor is not adjusted properly.	Check the position of the upper and lower media sensors. See “Positioning the Media Sensors” on page 10.
The printer is set for non-continuous media, but continuous media is loaded.	Either load the correct media or set the printer for the correct media type via the front panel.
	Ensure that the printer driver or software settings are correctly set (if applicable).
	Calibrate the printer (see page 17).
The incorrect media sensor is being used.	Via the front panel, check the sensor type to ensure that the correct one is used for the media loaded. See page 16. Calibrate the printer (see page 17).
The maximum label length is set shorter than the label length being used.	Via the front panel, set the label length to a value that is slightly longer than the length of the label being used.

## Error Condition — Head Open

<b>Problem</b>	<b>Solution</b>
The printhead is not fully closed.	Close the printhead.

## Warning — Ribbon In

<b>Problem</b>	<b>Solution</b>
The ribbon is loaded.	Remove the ribbon and set the printer to direct thermal mode.
	Ensure that the printer driver and/or software settings are correctly set (if applicable).

## Warning — Head Too Hot

<b>Problem</b>	<b>Solution</b>
The printhead is over temperature.	Allow the printer to cool. Printing automatically resumes when the printhead elements cool to an acceptable operating temperature.

## Warning — Head Cold

Problem	Solution
The printhead is under temperature.	Continue printing while the printhead reaches the correct operating temperature. If the error remains, the environment may be too cold for proper printing. Relocate the printer to a warmer area.

## Warning — Cutter Jammed

Problem	Solution
Cutter blade is in the media path.	Turn off the printer power and unplug the printer. Inspect the cutter module for debris and clean as needed following the cleaning instructions on page 68.

## Out of Memory\*

Problem	Solution
*There is not enough memory to perform the function shown on the second line of the error message.	Insufficient memory for the label length, downloaded fonts/graphics, and images.
	Ensure that the device, such as FLASH memory or PCMCIA card, is installed and not write protected or full.
	Ensure that the data is not directed to a device that is not installed or available.

# Print Quality Problems

## General Print Quality Issues

Problem	Solution
You are using an incorrect media and ribbon combination for your application.	Consult your authorized Brady distributor for information and advice.
The printer is set at the incorrect print speed.	For optimal print quality, set the print speed to the lowest possible setting via ZPL II, the driver, or the software.
The printer is set at the incorrect darkness level.	For optimal print quality, set the darkness to the lowest possible setting via the front panel, the driver, or the software.
The printhead is dirty.	Clean the printhead according to the instructions on page 64.
There is light printing (or no printing) on the left or right side of the label or the printed image is not sharp.	The toggle pressure needs to be adjusted. Follow the printhead pressure adjustment instructions on page 70.

## Gray lines on blank labels with no consistent pattern

Problem	Solution
The printhead is dirty.	Clean the printhead according to the instructions on page 64.

## Light, consistent vertical lines running through all of the labels

Problem	Solution
The printhead or platen roller is dirty.	Clean the printhead, platen roller, or both according to the instructions on page 64.

## Intermittent creases on the left and right edges of the labels

Problem	Solution
There is too much toggle pressure on the printhead.	Reduce the toggle pressure. See "Printhead Pressure Adjustment" on page 70.

## Wrinkled Ribbon

Problem	Solution
The ribbon is not loaded correctly.	Load the ribbon correctly. See "Ribbon Loading" on page 37.
The darkness setting is incorrect.	Set the darkness to the lowest possible setting for good print quality. See "DARKNESS" on page 44.
Incorrect printhead pressure or balance.	Set the pressure to the minimum required for good print quality. See "Printhead Pressure Adjustment" on page 70.
The media is not feeding correctly. It is "walking" from side to side.	Make sure that the media guide and media supply guide touch the edge of the media.

## Communications

**A label format was sent to the printer but not recognized. The DATA light does not flash.**

Problem	Solution
The communication parameters are incorrect.	Check the printer driver or software communications settings (if applicable).
	Check the printer host port setting via the front panel (see page 52). Select the port that matches the one being used by the host.
	Ensure you are using the correct communication cable. See page 22 for the requirements.
	Via the front panel, check the protocol setting. It should be set to "none." See page 53.
	Ensure that the correct driver is being used, if applicable.

**A label format was sent to the printer. Several labels print, then the printer skips, misplaces, misses, or distorts the image on the label.**

<b>Problem</b>	<b>Solution</b>
The host is set to EPP parallel communications.	Change the settings on the computer host to standard parallel communications.
The serial communication settings are incorrect.	Ensure that the flow control settings match.
	Check the communication cable length. See page 22 for requirements.
	Check the printer driver or software communications settings (if applicable).

**A label format was sent to the printer but not recognized. The DATA light flashes but no printing occurs.**

<b>Problem</b>	<b>Solution</b>
The prefix and delimiter characters set in the printer do not match the ones in the label format.	Verify the prefix and delimiter characters. See page 55.
Incorrect data is being sent to the printer.	Ensure that ZPL is being used.
	Check the communication settings on the computer. Ensure that they match the printer settings.

**The printer fails to calibrate or detect the top of the label.**

<b>Problem</b>	<b>Solution</b>
The printer was not calibrated for the label being used.	Perform the calibration procedure on page 17.
The printer is configured for continuous media.	Set the media type to non-continuous media.
The driver or software configuration is not set correctly.	As driver or software settings produce ZPL commands that can overwrite the printer configuration, check the driver or software media-related setting.

# Printer Diagnostics

## *Power-On Self Test*

A limited Power-On Self Test (POST) is performed automatically each time the printer is turned on (additional self tests can be performed by pressing the CANCEL key when you turn the printer on). During either test sequence, the front panel lights and liquid crystal display (LCD) monitor the progress of the POST. If the printer fails any of these tests, the word “FAILED” is added to the display. If this occurs, notify an authorized Brady distributor.

## *Additional Printer Self Tests*

These self tests produce sample printouts and provide specific information that help determine the operating conditions for the printer.

Each self test is enabled by pressing a specific front panel key or combination of keys while turning the POWER switch on. Keep the key(s) depressed until the DATA light turns off. When the Power-On Self Test is complete, the selected self test starts automatically.



**NOTES:** When performing self tests, avoid sending a label format to the printer. In the case of a remote host, disconnect all data interface cables from the printer.

When canceling a self test prior to its actual completion, always turn the printer power off and then back on to reset the printer.

When performing these self tests while in the Peel-Off mode, you must remove the labels as they become available.

If your media is not wide enough or long enough, unexpected and/or undesired results may occur. Make sure that your print width is set correctly for the media you are using before you run any self tests, otherwise the test may print out on the platen roller. See page 46 for information on setting the print width.

## CANCEL Key Self Test

This self test prints a listing of the configuration parameters currently stored in the printer's memory. See Figure 31 (depending on the options ordered, your label may look different).

1. Turn the printer off.
2. Press and hold the CANCEL key while turning on the power.

The configuration may be changed either temporarily (for specific label formats or ribbon and label stock) or permanently (by saving the new parameters in memory). Saving new parameters occurs whenever a calibration procedure is performed. Refer to page 15 for further information about the configuration procedure. Additional Power-Up Self Tests are also performed during the POST for this test.

PRINTER CONFIGURATION	
BRADY CORPORATION	
ZTC 1055L-200dpi	
+10.....	DARKNESS
+000.....	TEAR OFF
TEAR OFF.....	PRINT MODE
CONTINUOUS.....	MEDIA TYPE
WEB.....	SENSOR TYPE
THERMAL-TRANS.....	PRINT METHOD
104 0/8 MM.....	PRINT WIDTH
1800.....	LABEL LENGTH
39.0IN 988MM.....	MAXIMUM LENGTH
PARALLEL.....	PARALLEL COMM.
RS232.....	SERIAL COMM.
9600.....	BAUD
8 BITS.....	DATA BITS
NONE.....	PARITY
1 STOP BIT.....	STOP BITS
XON/XOFF.....	HOST HANDSHAKE
NONE.....	PROTOCOL
000.....	NETWORK ID
NORMAL MODE.....	COMMUNICATIONS
< > 7EH.....	CONTROL PREFIX
< > 5EH.....	FORMAT PREFIX
< > 2CH.....	DELIMITER CHAR
ZPL II.....	ZPL MODE
CALIBRATION.....	MEDIA POWER UP
CALIBRATION.....	HEAD CLOSE
DEFAULT.....	BACKFEED
+000.....	LABEL TOP
+0000.....	LEFT POSITION
0740.....	HEAD RESISTOR
057.....	WEB S.
089.....	MEDIA S.
071.....	RIBBON S.
000.....	MARK S.
001.....	MARK MED S.
003.....	MEDIA LED
004.....	RIBBON LED
024.....	MARK LED
+10.....	LCD ADJUST
DPSMFXM.....	MODES ENABLED
.....	MODES DISABLED
832 B/MM FULL.....	RESOLUTION
V40.10.0 <-.....	FIRMWARE
.....	HARDWARE ID
CUSTOMIZED.....	CONFIGURATION
4096.....	R: RAM
NONE.....	B: MEMORY CARD
1536.....	ONBOARD FLASH
NONE.....	E: FORMAT CONVERT
005 DISPLAY.....	J12 INTERFACE
007 POWER SUPPLY.....	J11 INTERFACE
*** NONE.....	J10 INTERFACE
.....	TWINAX/COAX ID
DYNAMIC.....	IP RESOLUTION
ALL.....	IP PROTOCOL
010.003.004.079.....	IP ADDRESS
255.255.255.000.....	SUBNET MASK
010.003.004.001.....	DEFAULT GATEWAY

FIRMWARE IN THIS PRINTER IS COPYRIGHTED

Figure 31



## PAUSE Key Self Test

This self test can be used to provide the test labels required when making adjustments to the printer's mechanical assemblies; these test labels also ensure the printhead has been aligned correctly after it has been adjusted. See the sample printout in Figure 32.

1. Turn off the printer.
2. Press and hold the PAUSE key while turning on the power.
  - The initial self test prints 15 labels at 2.4"/61 mm per second, then automatically pauses the printer. When the PAUSE key is pressed, an additional 15 labels print.
  - While the printer is paused, pressing the CANCEL key alters the self test. When the PAUSE key is pressed, the printer prints 15 labels at 6"/152 mm per second.
  - While the printer is paused, pressing the CANCEL key again alters the self test again. When the PAUSE key is pressed, the printer prints 50 labels at 2.4"/61 mm per second.
  - While the printer is paused, pressing the CANCEL key again alters the self test a third time. When the PAUSE key is pressed, the printer prints 50 labels at 6"/152 mm per second.
  - While the printer is paused, pressing the CANCEL key again alters the self test a fourth time. When the PAUSE key is pressed, the printer prints 15 labels at the printer's maximum speed.
  - To exit this self test at any time, press and hold the CANCEL key.



**Figure 32**



## FEED Key and PAUSE Key Self Test

1. Turn off the printer.
2. Press and hold the FEED and PAUSE keys while turning on the power.

Performing this self test temporarily resets the printer configuration to the factory default values. These values are active only until power is turned off unless you save them permanently in memory.

## Communications Diagnostics Test

This test is controlled from the front panel display. Refer to page 54. A typical printout from this test is shown in Figure 34. Turn off the power to exit this self test.



**NOTE:** This label is inverted when printed.

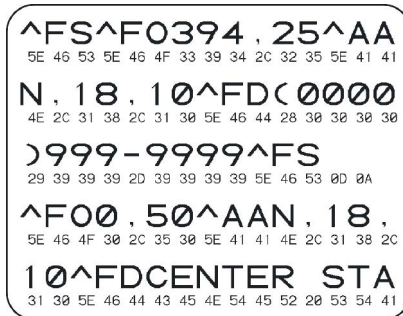

Figure 34

## Additional Printer Diagnostics

Additional diagnostic tests are available for this printer, however, they are beyond the scope of this user's guide. Refer to the maintenance manual for information about these additional tests.



# Specifications



**NOTE:** Printer specifications are subject to change without notice.

## Media Handling

- **Tear-off** mode: Labels are produced in strips.
- **Peel-off** mode: Labels are dispensed and peeled from the liner as needed.
- **Cutter** mode: Labels are printed and individually cut.
- **Rewind** mode: Labels are rewound internally.

## Options

• Cutter and catch tray	• PCMCIA Card Slot (Factory only)
• Rewind	• Bar-One® Windows™-based WYSIWYG on-screen label design and print application software
• Label peel and liner rewind	• ZebraNet PrintServer II, including Ethernet interface (10Base-T), WebView graphical setup and printer control, and Alert unsolicited error notification
• Internal fan-fold media supply bin*	• IBM® twinax or coax interface
• Font cards	

\* Not compatible with rewind and peel options.

# Zebra Programming Language (ZPL II®)

<ul style="list-style-type: none"> <li>Downloadable graphics, scalable and bitmap fonts, and label formats</li> </ul>	<ul style="list-style-type: none"> <li>Status message to host upon request</li> </ul>
<ul style="list-style-type: none"> <li>Object copying between memory areas (RAM, memory card, and internal FLASH)</li> </ul>	<ul style="list-style-type: none"> <li>Programmable quantity with print, pause, and cut control</li> </ul>
<ul style="list-style-type: none"> <li>Code Page 850 character set</li> </ul>	<ul style="list-style-type: none"> <li>Communicates in printable ASCII characters</li> </ul>
<ul style="list-style-type: none"> <li>Adjustable print cache</li> </ul>	<ul style="list-style-type: none"> <li>Error-checking protocol</li> </ul>
<ul style="list-style-type: none"> <li>Data compression</li> </ul>	<ul style="list-style-type: none"> <li>Controlled via mainframe, mini-computer, PC, portable data terminal</li> </ul>
<ul style="list-style-type: none"> <li>Automatic virtual input buffer management</li> </ul>	<ul style="list-style-type: none"> <li>Serialized fields</li> </ul>
<ul style="list-style-type: none"> <li>Format inversion</li> </ul>	<ul style="list-style-type: none"> <li>In-spec OCR-A and OCR-B</li> </ul>
<ul style="list-style-type: none"> <li>Mirror image printing</li> </ul>	<ul style="list-style-type: none"> <li>UPC/EAN</li> </ul>
<ul style="list-style-type: none"> <li>Four-position field rotation (0°, 90°, 180°, 270°)</li> </ul>	<ul style="list-style-type: none"> <li>User-programmable password</li> </ul>
<ul style="list-style-type: none"> <li>Slew command</li> </ul>	

## Bar Codes

<ul style="list-style-type: none"> <li>Bar code ratios - 2:1, 7:3, 5:2, 3:1</li> </ul>	<ul style="list-style-type: none"> <li>Industrial 2of 5 (supports ratios of 2:1 up to 3:1, Modulus 10 Check Digit)</li> </ul>
<ul style="list-style-type: none"> <li>Code 11</li> </ul>	<ul style="list-style-type: none"> <li>Interleaved 2 of 5</li> </ul>
<ul style="list-style-type: none"> <li>Code 39 (supports ratios of 2:1 up to 3:1)</li> </ul>	<ul style="list-style-type: none"> <li>LOGMARS</li> </ul>
<ul style="list-style-type: none"> <li>Code 93</li> </ul>	<ul style="list-style-type: none"> <li>MSI</li> </ul>
<ul style="list-style-type: none"> <li>Code 128 (with subsets A, B, and C and UCC case codes)</li> </ul>	<ul style="list-style-type: none"> <li>Codabar</li> </ul>
<ul style="list-style-type: none"> <li>ISBT-128</li> </ul>	<ul style="list-style-type: none"> <li>Codablock (2-dimensional bar code)</li> </ul>
<ul style="list-style-type: none"> <li>UPC-A, UPC-E, UPC extensions</li> </ul>	<ul style="list-style-type: none"> <li>PDF-417 (2-dimensional bar code)</li> </ul>
<ul style="list-style-type: none"> <li>EAN-8, EAN-13, EAN extensions</li> </ul>	<ul style="list-style-type: none"> <li>Code 49 (2-dimensional bar code)</li> </ul>
<ul style="list-style-type: none"> <li>Plessey</li> </ul>	<ul style="list-style-type: none"> <li>DataMatrix (2-dimensional bar code)</li> </ul>
<ul style="list-style-type: none"> <li>Postnet</li> </ul>	<ul style="list-style-type: none"> <li>Maxi Code (2-dimensional bar code)</li> </ul>
<ul style="list-style-type: none"> <li>Standard 2of 5</li> </ul>	<ul style="list-style-type: none"> <li>QR Code (2-dimensional bar code)</li> </ul>
<ul style="list-style-type: none"> <li>Check digit calculation where applicable</li> </ul>	

# General Specifications

General Specifications			200M-e/200M-e 300	
Height			15.5"	394 mm
Width			11.2"	283 mm
Depth			19.5"	459 mm
Weight (without options)			55 lb	25 kg
Electrical	General (auto adjusting)		90-264 VAC; 48-62 Hz	
	Power Consumption	Printing PAUSE test label at slowest speed	180 W	
		Printer idle	19 W	
	Compliance		Complies with FCC class "A" and Canadian Doc. class "A" rules. Carries the CE mark of compliance.	
Temperature	Operating environment	Thermal transfer	41° to 104° F	5° to 40° C
		Direct thermal	32° to 104° F	0° to 40° C
	Storage	-40° to 140° F	-40° to 60° C	
Relative Humidity	Operating environment		20% to 85% non-condensing	
	Storage		5% to 85% non-condensing	

# Printing Specifications

Printing Specifications			200M-e/200M-e 300
Resolution			203 dots/inch (8 dots/mm)/ 300 dots/inch (12 dots/mm)
Dot size (width x length)			0.0049" x 0.0049" (0.125 x 0.125 mm)/ 0.0033" x 0.0039" (0.84 mm x 0.10 mm)
First dot location measured from inside media edge			0.10" ± 0.035" (2.5 mm ± 0.89 mm)
Maximum print width			4.09" (104 mm)
Print Length (maximum)	Continuous printing (with standard 4 MB memory)	203 dpi	90" (2337 mm)
		300 dpi	41" (1041 mm)
Media registration toleration* (non-continuous media)		Vertical	= ≤ ±0.050" (1.3 mm)
		Horizontal	= ≤ ±0.050" (1.3 mm)
Programmable print speeds		203 dpi	2.0" (51 mm) through 8.0" (203 mm) per second in 1" increments
		300 dpi	2.0" (51 mm) through 8.0" (203 mm) per second in 1" increments
Bar code modulus ("X") dimension	Ladder (rotated) orientation	203 dpi	4.9 mil to 49 mil
		300 dpi	3.9 mil to 39 mil
	Picket fence (non-rotated) orientation	203 dpi	4.9 mil to 49 mil
		300 dpi	3.9 mil to 39 mil
Thin film printhead with Element Energy Equalizer (E <sup>3</sup> )®			Yes

\* Media registration and minimum label length are affected by media type and width, ribbon type, and print speed. Performance improves as these factors are optimized. Brady recommends always qualifying any application with thorough testing.

# Ribbon Specifications

Ribbon Specifications		200M-e/200M-e 300
Ribbon must be wound with the coated side out.		
Ribbon width ( <i>Brady recommends using ribbon at least as wide as the media to protect the printhead from wear.</i> )	Minimum	0.79" (20 mm)
	Maximum	4.1" (104 mm)
Standard lengths	2:1 media to ribbon roll ratio	984 ft. (300 m)
	3:1 media to ribbon roll ratio	1476 ft. (450 m)
Ribbon core inside diameter		1.0" (25.4 mm)
Maximum ribbon roll outside diameter		3.2" (81.3 mm)



## Font Specifications

203 dpi (8 dots/mm)				
Fonts	Matrix (in dots) (H x W)	Type*	Minimum Char. Size (H x W)	Maximum C.P.I.
A	9 x 5	U-L-D	0.044" x 0.029"	33.9
B	11 x 7	U	0.054" x 0.44"	22.6
C,D	18 x 10	U-L-D	0.088" x 0.059"	16.9
E	28 x 15	OCR-B	0.138" x 0.098"	10.1
F	26 x 13	U-L-D	0.128" x 0.079"	12.7
G	60 x 40	U-L-D	0.295" x 0.236"	4.2
H	21 x 13	OCR-A	0.103" x 0.093"	10.7
GS	24 x 24	SYMBOL	0.118" x 0.118"	8.4
∅	variable	U-L-D	variable	N/A

300 dpi (12 dots/mm)				
Fonts	Matrix (in dots) (H x W)	Type*	Minimum Char. Size (H x W)	Maximum C.P.I.
A	9 x 5	U-L-D	0.030" x 0.020"	50.0
B	11 x 7	U	0.037" x 0.030"	33.3
C,D	18 x 10	U-L-D	0.060" x 0.040"	25.0
E	41 x 20	OCR-B	0.137" x 0.087"	11.5
F	26 x 13	U-L-D	0.087" x 0.052"	18.8
G	60 x 40	U-L-D	0.200" x 0.160"	6.3
H	30 x 19	OCR-A	0.100" x 0.093"	10.7
GS	24 x 24	SYMBOL	0.080" x 0.080"	12.5
∅	variable	U-L-D	variable	N/A

\* U = Uppercase; L = Lowercase; D = Descenders

- Bitmap fonts A through H and GS symbols are expandable up to 10 times, height and width independent.
- Smooth scalable font ∅ (CG Triumvirate™ Bold Condensed) is expandable dot-by-dot, height and width independent.
- IBM® Code Page 850 International Characters.

# Media Specifications

Media Specifications		200M-e/200M-e 300		
Minimum label length*	Tear-off	0.7" (18 mm)		
	Peel-off	0.5" (13 mm)		
	Cutter	1.5" (38 mm)		
	Rewind	0.25" (6 mm)		
Total media width (label + liner, if any)	Minimum	0.79" (20 mm)		
	Maximum	4.52 mm (115 mm)		
Total thickness (includes liner, if any)	Minimum	0.003" (0.076 mm)		
	Maximum	0.012" (0.305 mm)		
Cutter maximum full-width media thickness		0.009" (.23 mm)		
Roll media core inside diameter		3" (76 mm)		
Maximum roll diameter		8.0" (203 mm)		
Inter-label gap	Minimum	0.079" (2 mm)		
	Preferred	0.118" (3 mm)		
	Maximum	Maximum inter-label gap = 2 x (label length for which you have calibrated the printer) + 1"		
Maximum internal fanfold media pack size (label + liner) L x W x H		8.0" x 4.5" x 4.5" (203 mm x 114 mm x 114 mm)		
Ticket/tag sensing notch L x W		0.12" x 0.25" (3 mm) x (6 mm)		
Ticket/tag sensing hole diameter		0.125" (3 mm)		
Additional specifications for black mark sensing	Mark length (measuring parallel to label/tag edge)	Minimum	0.12" (3 mm)	
		Maximum	0.43" (11 mm)	
	Mark width (measuring to perpendicular label/ tag edge)	Minimum	≥ 0.43" (≥ 11 mm)	
		Maximum	Full media width	
	Mark location		Marks must be located within 0.040" (1 mm) of the inside media edge.	
	Mark density		>1.0 Optical Density Unit (ODU)	
Maximum density of the back of the media on which the black mark is printed		0.5 ODU		

\* Media registration and minimum label length are affected by media type and width, ribbon type, print speed, and printer mode of operation. Performance improves as these factors are optimized. Brady recommends always qualifying any application with thorough testing.

# Power Line Cord Specifications

- The overall length must be less than 9.8 feet (3.0 meters).
- It must be rated for at least 5 A, 250 V.
- The chassis ground (earth) **MUST** be connected to assure safety and reduce electromagnetic interference. The ground connection is handled by the third wire (earth) in the power line cord. See Figure 35.

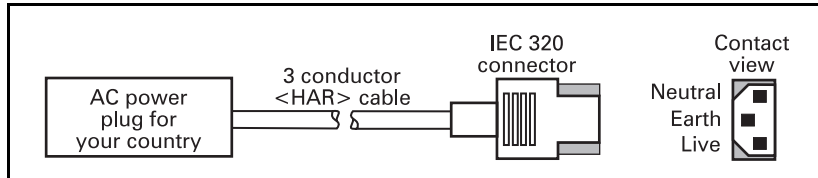

**Figure 35**

- The AC power plug and IEC 320 connector must bear the certification mark of at least one of the known international safety organizations shown in Figure 36.

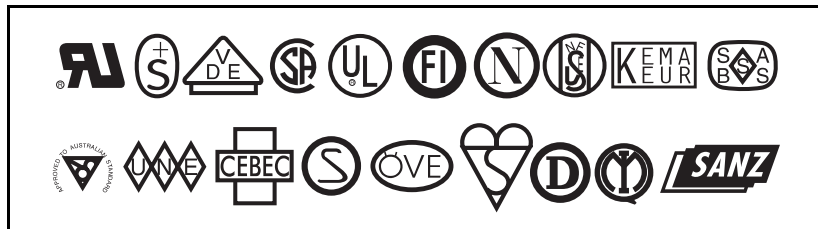

**Figure 36**



# Bradyprinter THT Models 200M-e and 200M-e 300

## Warranty Information

### 1. Printer Warranty

BRADY printers, excluding thermal printheads which are warranted separately below, are warranted against defects in material or workmanship for six (6) months from the date of original shipment by BRADY CORPORATION. This warranty does not cover normal wear and tear and shall be null and void if the equipment is modified, improperly installed or used, damaged by accident or neglect, or in the event any parts are improperly installed or replaced by the user.

Since printhead wear is part of normal operations, the original printhead and replacement printheads are covered by a limited warranty of six (6) months from the date of original shipment by BRADY CORPORATION. To qualify for this warranty, the printer must be returned to the factory or other authorized service center. Although the user is not required to purchase BRADY brand supplies (media and/or ribbons), to the extent it is determined that the use of other supplies (media and/or ribbons) shall have caused any defect in the thermal printhead for which a warranty claim is made, the user shall be responsible for BRADY CORPORATION's customary charges for labor and materials to repair such defect. To the extent that it is determined that failure to follow the preventive maintenance schedule and procedures listed in the User Guide shall have caused any defect in the thermal printhead for which a warranty claim is made, this limited warranty shall be void.

---

**BRADY CORPORATION'S SOLE OBLIGATION UNDER THIS WARRANTY SHALL BE TO FURNISH PARTS AND LABOR FOR THE REPAIR OR REPLACEMENT OF PRODUCTS FOUND TO BE DEFECTIVE IN MATERIAL OR WORKMANSHIP DURING THE WARRANTY PERIOD.**

---

As a condition of this warranty, the user must: (a) obtain a BRADY Return Authorization for the printer, or subassembly(s); (b) ship the printer or subassembly(s), transportation prepaid to the authorized service location; and (c) include with the Product or subassembly(s) a written description of the claimed defect. Unless BRADY CORPORATION authorizes return of the entire Product, the user shall return only the subassembly(s). Products returned shall be packaged in the original packing and shipping container or comparable container. In the event equipment is not so packaged or if shipping damage is evident, it will not be accepted for service under warranty. Surface transportation charges for the return of the printer to the customer shall be paid by BRADY CORPORATION within the 48 contiguous states and the District of Columbia. Customer shall pay shipping costs, customs clearance, and other related charges outside the designated area. If BRADY CORPORATION determines that the Product returned to it for warranty service or replacement is not defective as herein defined, BUYER shall pay all costs of handling and transportation.

## ***2. Warranty Exclusions and Conditions***

The above warranties are in lieu of all other warranties, expressed or implied, oral or written, statutory or otherwise, including any implied warranty of merchant-ability or fitness for a particular purpose.

BRADY CORPORATION shall not be responsible for the specific application to which any Products are applied, including but not limited to compatibility with other equipment.

All statements, technical information and recommendations relating to BRADY Products are based upon tests believed to be reliable but do not constitute a guarantee or warranty.

---

**BRADY CORPORATION SHALL NOT, UNDER ANY CIRCUMSTANCES WHATSOEVER, BE LIABLE TO BUYER OR ANY OTHER PARTY FOR LOST PROFITS, DIMINUTION OF GOOD WILL OR ANY OTHER SPECIAL OR CONSEQUENTIAL DAMAGES WHATSOEVER WITH RESPECT TO ANY CLAIM HEREUNDER. IN ADDITION, BRADY CORPORATION'S LIABILITY FOR WARRANTY CLAIMS SHALL NOT, IN ANY EVENT, EXCEED THE INVOICE PRICE OF THE PRODUCT CLAIMED DEFECTIVE, NOR SHALL BRADY CORPORATION BE LIABLE FOR DELAYS IN REPLACEMENT OR REPAIR OF PRODUCTS.**

---

No salesperson, representative or agent of BRADY CORPORATION is authorized to make any guarantee, warranty, or representation in addition to the foregoing warranty.

---

**NO WAIVER, ALTERATION, ADDITION, OR MODIFICATION OF THE FOREGOING WARRANTIES SHALL BE VALID UNLESS MADE IN WRITING AND SIGNED BY AN EXECUTIVE OFFICER OF BRADY CORPORATION.**

---

# *BradyConnect License Agreement*

## **Printer Software and Firmware License Agreement**

YOU SHOULD CAREFULLY READ THE FOLLOWING TERMS AND CONDITIONS OF THIS BRADY CORPORATION PRINTER SOFTWARE AND FIRMWARE LICENSE AGREEMENT ("PSFLA") BEFORE USING THE PRINTER WHICH IS ENCLOSED OR OTHERWISE ASSOCIATED WITH THIS AGREEMENT. IF YOU DO NOT AGREE WITH THESE TERMS AND CONDITIONS, DO NOT OPERATE THE PRINTER AND PLEASE PROMPTLY RETURN THE PRINTER, ENCLOSURES AND ALL PACKAGING FOR A FULL REFUND.

Brady Corporation ("BRADY") hereby grants you a non-exclusive, non-transferable license to use the SOFTWARE and FIRMWARE embedded in the printer and the accompanying documentation according to the following terms:

1. The printer enclosed with or otherwise associated with this Agreement has or includes certain SOFTWARE and FIRMWARE therein which is protected by copyright laws and international copyright treaties, as well as other intellectual property laws and treaties. The SOFTWARE and FIRMWARE is licensed, not sold. Such SOFTWARE and/or FIRMWARE may include, but is not limited to, SOFTWARE and/or FIRMWARE that is licensed under one or more of the following trademarks: ZPL (Zebra Programming Language), ZebraLink, Web View, Web Alert, ZBI (Zebra Basic Interpreter), BarOne, ZTools, Utilities, ZebraNet View for IP, ZebraNet Alert, PC Management Program, ZebraNet View for Networks and ZebraNet Connect.
2. GRANT OF LICENSE. This License grants you the following rights:
  - SOFTWARE and FIRMWARE. You may use, access, display, run, or otherwise interact with ("RUN") the SOFTWARE and FIRMWARE in connection with operating the printer which is enclosed with or otherwise associated with this PSFLA ("PRINTER"). The primary user of the PRINTER may make a second copy for his or her exclusive use on a portable computer/printer.
  - Storage/Network Use. You may also store or install a copy of the SOFTWARE and FIRMWARE on a storage device, such as a network server, used only to RUN the SOFTWARE and FIRMWARE on your other PRINTERS over an internal network; however, you must acquire and dedicate a license for each separate PRINTER on which the SOFTWARE and FIRMWARE is RUN from the storage device. A license for the SOFTWARE and FIRMWARE may not be shared or used concurrently on different PRINTERS.
  - Reservation of Rights. All rights not expressly granted are reserved by BRADY.
  - Accessing Services Using the SOFTWARE and FIRMWARE. Your use of any service accessible using the SOFTWARE and FIRMWARE is not covered by this PSFLA and may be governed by separate terms of use, conditions or notices.

### 3. RESTRICTIONS.

- You must maintain all copyright notices on all copies of the SOFTWARE and FIRMWARE.
  - Limitations on modification. You may not modify, adapt, translate, or create derivative works based on this SOFTWARE OR FIRMWARE or the accompanying documentation.
  - Limitations of Reverse Engineering, Decompilation and Disassembly. You may not reverse engineer, decompile, or disassemble the SOFTWARE or the FIRMWARE, except and only to the extent that such activity is permitted by applicable law notwithstanding this limitation.
  - Rental. You may not rent or lease or lend the SOFTWARE or FIRMWARE.
  - Support Services. BRADY may provide you with support services related to the SOFTWARE and/or FIRMWARE ("SUPPORT SERVICES"), in its discretion. Use of SUPPORT SERVICES, if any, is governed by the BRADY policies and programs described in the user manual, in "online" documentation, and/or other BRADY provided materials. Any supplemental SOFTWARE or FIRMWARE code provided to you as a part of SUPPORT SERVICES shall be considered part of the SOFTWARE and/or FIRMWARE and is subject to the terms of this PSFLA. With respect to technical information you provide to BRADY as part of the SUPPORT SERVICES, BRADY may use such information for its business purposes, including for product support and development. BRADY will not utilize such technical information in a form that personally identifies you except to the extent necessary to provide you with support.
  - Replacement, Modification and Upgrade of the SOFTWARE and/or FIRMWARE. BRADY reserves the right to replace, modify or upgrade the SOFTWARE and/or FIRMWARE at any time by offering you a replacement or modified version of the SOFTWARE and/or FIRMWARE or such upgrade and to charge for such replacement, modification or upgrade. Any such replacement or modified SOFTWARE and/or FIRMWARE code or upgrade to the SOFTWARE and/or FIRMWARE offered to you by BRADY shall be considered part of the SOFTWARE and/or FIRMWARE and subject to the terms of this PSFLA (unless this PSFLA is superseded by a further PSFLA accompanying such replacement or modified version of or upgrade to the SOFTWARE and/or FIRMWARE). In the event that BRADY offers a replacement or modified version of or any upgrade to the SOFTWARE and/or FIRMWARE, (a) your continued use of the SOFTWARE and/or FIRMWARE is conditioned on your acceptance of such replacement or modified version of or upgrade to the SOFTWARE and/or FIRMWARE and any accompanying superseding PSFLA and (b) in the case of the replacement or modified SOFTWARE and/or FIRMWARE, your use of all prior versions of the SOFTWARE and/or FIRMWARE is terminated.
4. **TERMINATION.** Without prejudice to any other rights, BRADY may terminate this PSFLA if you fail to comply with the terms and conditions of this PSFLA. BRADY may terminate this PSFLA by offering you a superseding PSFLA for the SOFTWARE and/or FIRMWARE or any replacement or modified version of or upgrade to the SOFTWARE and/or FIRMWARE and conditioning your continued use of the SOFTWARE and/or FIRMWARE or such replacement, modified or upgraded version on your acceptance of such superseding PSFLA. In addition, BRADY may terminate this PSFLA by notifying you that your continued use of the SOFTWARE and/or FIRMWARE is prohibited. In the event that BRADY terminates this PSFLA, you must immediately stop using the SOFTWARE and/or FIRMWARE and destroy all copies of the SOFTWARE and/or FIRMWARE and all of its component parts.
5. **COPYRIGHT.** All title and copyrights in and to the SOFTWARE and FIRMWARE, the accompanying printed materials, and any copies of the SOFTWARE and FIRMWARE, are owned by BRADY or its suppliers. All title and intellectual property rights in and to the content which may be accessed through use of the SOFTWARE and/or FIRMWARE is the property of the respective content owner and may be protected by applicable copyright or other intellectual property laws and treaties. This PSFLA grants you no rights to use such content. If this SOFTWARE and/or FIRMWARE contains documentation which is provided only in electronic form, you may print one copy of such electronic documentation. You may not copy the printed materials accompanying the SOFTWARE and/or FIRMWARE.



6. U.S. GOVERNMENT RESTRICTED RIGHTS. All SOFTWARE and/or FIRMWARE provided to the U.S. Government pursuant to solicitations issued on or after December 1, 1995 is provided with the commercial rights and restrictions described elsewhere herein. All SOFTWARE and/or FIRMWARE provided to the U.S. Government pursuant to solicitations issued prior to December 1, 1995 is provided with RESTRICTED RIGHTS as provided for in FAR, 48 CFR 52.227-14 (JUNE 1987) or DFAR, 48 CFR 252.227-7013 (OCT 1988), as applicable.
7. EXPORT RESTRICTIONS. You agree that you will not export or re-export the SOFTWARE and/or FIRMWARE, any part thereof, or any process or service that is the direct product of the SOFTWARE and/or FIRMWARE (the foregoing collectively referred to as the "RESTRICTED COMPONENTS"), to any country, person or entity subject to U.S. export restrictions. You specifically agree not to export or re-export any of the RESTRICTED COMPONENTS (i) to any country to which the U.S. has embargoed or restricted the export of goods or services, which currently include, but are not necessarily limited to Cuba, Iran, Iraq, Libya, North Korea, Sudan and Syria, or to any national of any such country, wherever located, who intends to transmit or transport the RESTRICTED COMPONENTS back to such country; (ii) to any person or entity who you know or have reason to know will utilize the RESTRICTED COMPONENTS in the design, development or production of nuclear, chemical or biological weapons; or (iii) to any person or entity who has been prohibited from participating in U.S. export transactions by any federal agency of the U.S. government. You warrant and represent that neither the U.S. Commerce Department, Bureau of Export Administration nor any other U.S. federal agency has suspended, revoked or denied your export privileges.
8. DISCLAIMER OF WARRANTIES. BRADY AND ITS SUPPLIERS PROVIDE THE SOFTWARE AND/OR FIRMWARE "AS IS" AND WITH ALL FAULTS, AND HEREBY DISCLAIM ALL OTHER WARRANTIES AND CONDITIONS, EITHER EXPRESS, IMPLIED OR STATUTORY, INCLUDING BUT NOT LIMITED TO ANY (IF ANY) IMPLIED WARRANTIES OR CONDITIONS OF MERCHANTABILITY, OF FITNESS FOR A PARTICULAR PURPOSE, OF LACK OF VIRUSES, AND OF LACK OF NEGLIGENCE OR LACK OF WORKMANLIKE EFFORT. ALSO, THERE IS NO WARRANTY OR CONDITION OF TITLE, OF QUIET ENJOYMENT, OR OF NONINFRINGEMENT. THE ENTIRE RISK ARISING OUT OF THE USE OR PERFORMANCE OF THE SOFTWARE AND FIRMWARE IS WITH YOU. BRADY DOES NOT WARRANT THAT THE OPERATION OF THE SOFTWARE OR FIRMWARE WILL BE UNINTERRUPTED OR ERROR FREE.
9. EXCLUSION OF ALL DAMAGES. TO THE MAXIMUM EXTENT PERMITTED BY APPLICABLE LAW, IN NO EVENT SHALL BRADY OR ITS SUPPLIERS BE LIABLE FOR ANY CONSEQUENTIAL, INCIDENTAL, DIRECT, INDIRECT, SPECIAL, PUNITIVE, OR OTHER DAMAGES WHATSOEVER (INCLUDING, WITHOUT LIMITATION, DAMAGES FOR ANY INJURY TO PERSON OR PROPERTY, DAMAGES FOR LOSS OF PROFITS, BUSINESS INTERRUPTION, LOSS OF BUSINESS INFORMATION, FOR LOSS OF PRIVACY FOR FAILURE TO MEET ANY DUTY INCLUDING OF GOOD FAITH OR OF REASONABLE CARE, FOR NEGLIGENCE, AND FOR ANY PECUNIARY OR OTHER LOSS WHATSOEVER) ARISING OUT OF OR IN ANY WAY RELATED TO THE USE OF OR INABILITY TO USE THE SOFTWARE OR FIRMWARE, WHETHER BASED ON CONTRACT, TORT, NEGLIGENCE, STRICT LIABILITY OR OTHERWISE, EVEN IF BRADY OR ANY SUPPLIER HAS BEEN ADVISED OF THE POSSIBILITY OF SUCH DAMAGES. THIS EXCLUSION OF DAMAGES SHALL BE EFFECTIVE EVEN IF ANY REMEDY FAILS OF ITS ESSENTIAL PURPOSE.

10. LIMITATIONS AND RELEASE OF LIABILITY.

- To the extent that the SOFTWARE and/or FIRMWARE covered by this PSFLA includes emulation libraries, emulation libraries are offered "as is". BRADY does not provide any warranty associated with the emulation libraries.
- The emulation library does not work 100% correctly or cover 100% of the functionality of the printer language being emulated. Modifications may be required for each target application. If such modification is necessary, prior to making any such modification, you are required to contact BRADY to obtain express written consent to make such modification.
- If the emulation library is sold separately by an authorized party other than BRADY ("RESELLER" -- A party other than BRADY which is authorized by BRADY to distribute the SOFTWARE and/or FIRMWARE with its application so long as the SOFTWARE and/or FIRMWARE is used with a BRADY printer) or is sold bundled with a printer to an end-user by a RESELLER, and if claims are made by the RESELLER that the emulation library performs as a 100% emulation solution, BRADY is not responsible if the emulation library does not work as advertised by the RESELLER. Furthermore, BRADY is not liable for any damages directly or indirectly relating to such emulation library which is sold separately by the RESELLER or which is sold bundled with a printer to an end-user by the RESELLER.
- The SOFTWARE and FIRMWARE was provided to you at no additional charge and BRADY has included in this PSFLA terms that disclaim all warranties and liability for the SOFTWARE and FIRMWARE. To the full extent allowed by law, YOU HEREBY RELEASE BRADY AND ITS SUPPLIERS FROM ANY AND ALL LIABILITY ARISING FROM OR RELATED TO ALL CLAIMS CONCERNING THE SOFTWARE AND/OR FIRMWARE OR ITS USE. If you do not wish to accept the SOFTWARE OR FIRMWARE under the terms of this PSFLA, do not use the PRINTER enclosed with or otherwise associated with this PSFLA.

11. GOVERNING LAW. If you acquired the SOFTWARE and/or FIRMWARE in the United States of America, the laws of the State of Illinois, U.S.A. will apply to this contract. If you acquired this SOFTWARE and/or FIRMWARE outside of the United States of America, then local law may apply. If any provision of this PSFLA is held invalid, the remainder of this PSFLA shall continue in full force and effect.

12. QUESTIONS. Should you have any questions, or if you desire to contact BRADY for any reason, please contact the BRADY subsidiary serving your country, or write:

Brady Corporation  
6555 West Good Hope Road  
P.O. Box 2131  
Milwaukee, WI 53201-2131

# Appendix A: DB9 Connectors

## Printer Interface Technical Information

### RS-232 Serial Data Port

The connection for this standard interface is made through the female DB9 connector on the rear panel. A DB9 to DB25 interface module is required for all RS-232 connections through a DB25 cable (see page 100 for details).

For all RS-232 input and output signals, the printer follows both the Electronics Industries Association's (EIA) RS-232 specifications and the Consultative Committee for International Telegraph and Telephone (CCITT) V.24 standard signal level specifications.

Table 3 shows the pin configuration and function of the rear panel serial data connector on the printer.

**Table 3**

Pin No.	Name	Description
1	—	Not connected
2	RXD	Receive data — data input to printer
3	TXD	Transmit data — data output from printer
4	DTR	Data terminal ready — output from printer
5	SG	Signal ground
6	DSR	Data set ready — input to printer
7	RTS	Request to send — output from printer
8	CTS	Clear to send — input to printer
9	+5VDC	+5VDC signal output <b>NOTE:</b> This pin is also available as a +5VDC power source at 750mA. To enable this capability, a jumper on the computer's main logic board needs to be installed on JP1, pins 2 and 3.



**NOTE:** An interface module is required for RS-422/RS-485 interface support (see page 101).

## RS-232 Interface Connections

The printer is configured as Data Terminal Equipment (DTE). Figure 37 illustrates the internal connections of the printer's RS-232 connector.

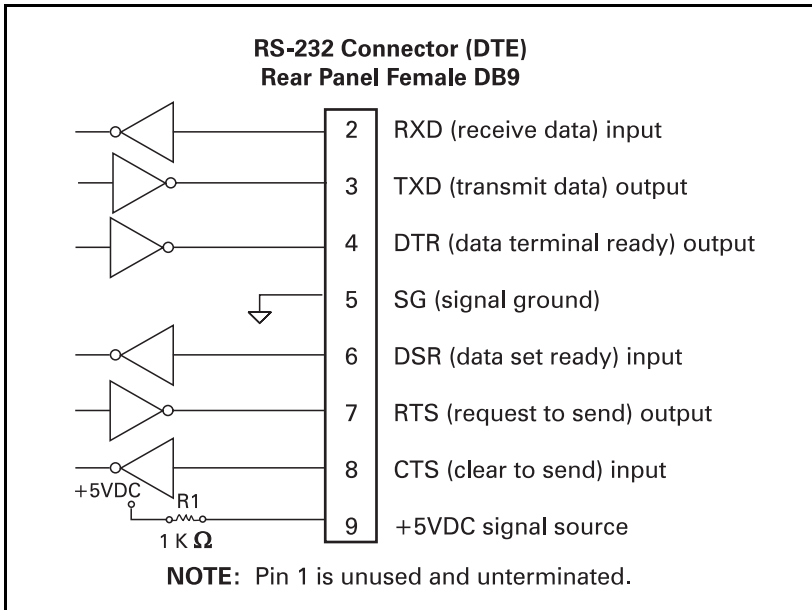
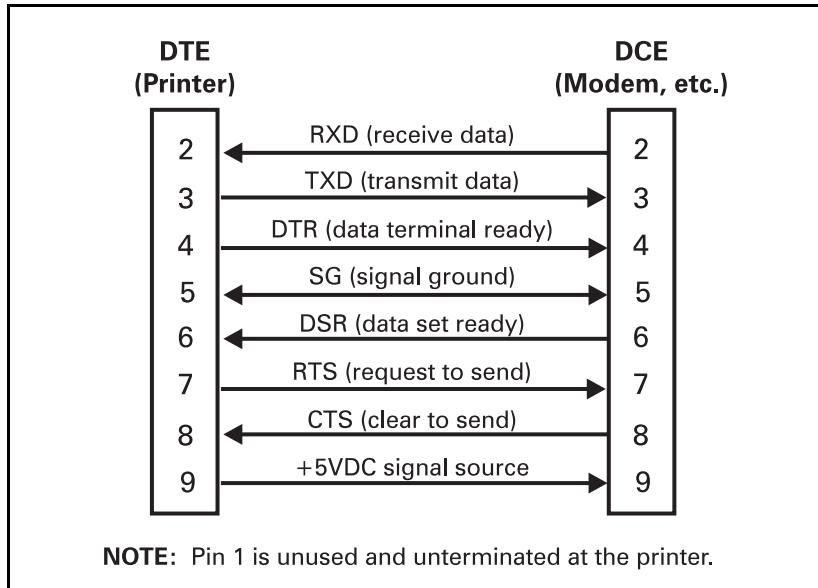

**Figure 37**



**NOTE:** The cable used to connect the printer to a computer must be a null modem (crossover) cable. If you want to connect the printer to any other DTE devices, a null modem cable must also be used.

When the printer is connected via its RS-232 interface to Data Communication Equipment (DCE) such as a modem, use a standard RS-232 (straight-through) interface cable. Figure 38 illustrates the connections required for this cable.



**Figure 38**

## RS-232 Interconnections Using a DB25 Cable

In order to connect the printer's RS-232 DB9 interface to a DB25 connector, an interface adapter is required. A generic DB25 adapter may also be used, however the +5VDC signal source would not be passed through. Figure 39 illustrates the connections required for the DB9 to DB25 interface.



**NOTE:** The cable used to connect the printer to a computer must be a null modem (crossover) cable. If you want to connect the printer to any other DTE devices, you must also use a null modem cable.

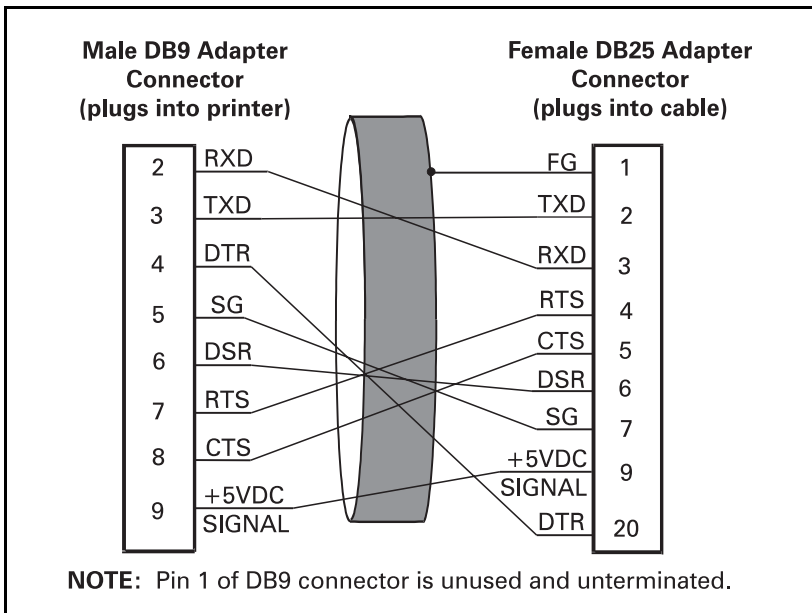

**Figure 39**

## RS-422/RS-485 Interconnections



**NOTE:** A jumper on the computer's main logic board needs to be installed on JP1, Pins 2 and 3, in order for the RS-422/RS-485 interface adapter to function properly.

To connect the printer's RS-232 DB9 interface to a host computer through an RS-422 or an RS-485 interface, an interface adapter is required. Figure 40 illustrates the required cable wiring for interconnecting to the interface adapter's DB25 female connector.

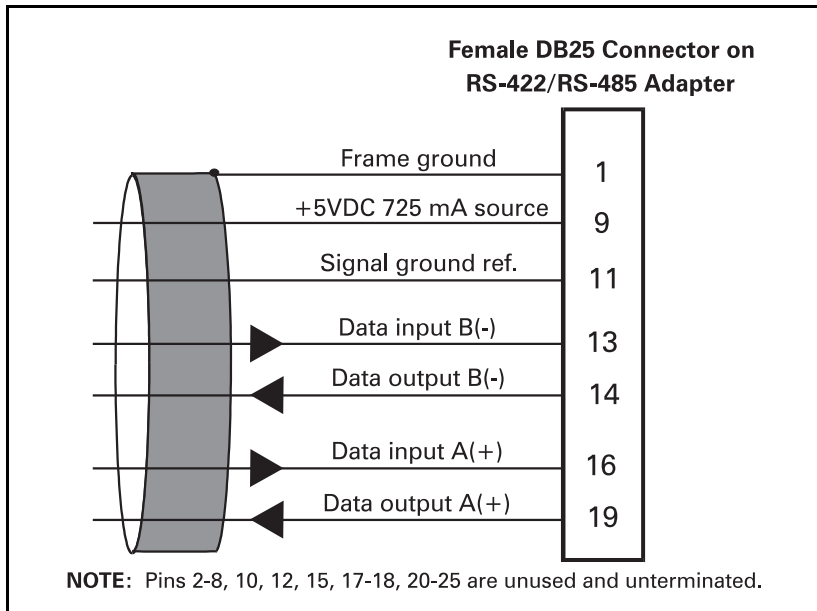

**Figure 40**

## Parallel Data Port

A standard 36-pin parallel connector is available at the rear of the printer for connection to the data source. Under normal circumstances, data sent from the printer to the host computer in response to a “Printer Status Request” command is sent through the RS-232 serial port. However, if the host computer has a properly configured IEEE-1284 parallel port that is recognized by the printer, status information is returned through the parallel port. Port selection for status information is determined each time the printer is turned on.

### Parallel Port Interconnections

Table 4 shows the pin configuration and function of a standard computer-to-printer parallel cable.

**Table 4**

36-pin Connector	Description
1	nStrobe/HostClk
2-9	Data Bits 1-8
10	nACK/PtrClk
11	Busy/PtrBusy
12	PError/ACKDataReq
13	Select/Xflag
14	nAutoFd/HostBusy
15	Not used
16 & 17	Ground
18	+5V @ 750mA
19-30	Ground
31	ninit
32	nFault/NDataAvail
33 & 34	Not used
35	+5V through a 1.8K $\Omega$ Resistor
36	NSelectin/1284 active



# Appendix B: PCMCIA Card

## PCMCIA Card Installation

The PCMCIA card slot is a factory-installed option. If your printer has this option, you may install or change the card at any time. Use the following procedure to install a PCMCIA card.



**CAUTION:** Observe proper electrostatic safety precautions when handling any static-sensitive components such as printed circuit boards and printheads.

1. Turn the AC power switch in the Off (O) position and disconnect the AC power cord. Disconnect the data cables.
2. Refer to Figure 41. Remove and retain the screw and the option card shield from the rear of the printer.
3. If you are replacing the card, press the card eject button and slide the card out of the slot.
4. Slide the new card into the slot far enough that the eject button pops out.
5. Reinstall the option card shield and secure it with the screw.
6. Reconnect the AC power cord and all data cables.
7. Press and hold the FEED key while placing the power switch in the On (I) position.
8. Verify the presence of additional memory or optional fonts by checking the information on the configuration label that was printed during the power on sequence.
9. The printer is now ready to operate with the additional memory or font option.

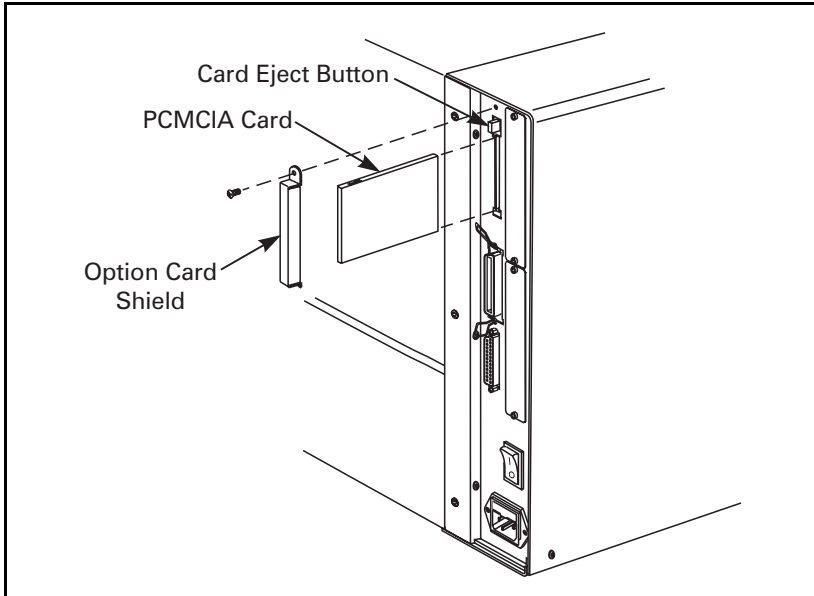

**Figure 41**

## A

### Adjustments

- Lower Media Sensor, 12
- Media Sensor Position, 70
- Printhead Pressure, 70
- Toggle Positioning, 69
- Upper Media Sensor, 11

## B

- Bar Codes, 84
- Black Mark Sensor Adjustment, 12
- BradyConnect License Agreement, 93

## C

- Cabling Requirements, 22
- Calibration, 5–20
- CANCEL Key Self Test, 78
- Cleaning
  - Cutter Module, 68
  - Exterior, 64
  - Interior, 64
  - Printhead and Platen Roller, 64
  - Sensors, 65
  - Snap Plate, 66
- Communications Diagnostics Test, 81
- Configuration
  - Calibration Sequence, 44–??
  - Entering the Setup Mode, 41
  - Leaving the Setup Mode, 43
  - Password-Protected Parameters, 42
  - Printer, 15
  - Software or Printer Driver, 16
- Continuous Media, 7
- Cutter Mode, 32

## D

- Damage, 1
- Data Ports
  - Parallel, 102
  - Serial, 97–101
- Data Specifications, 21

## F

- Fanfold Media Loading, 35
- FEED Key and PAUSE Key Self Test, 81
- FEED Key Self Test, 80
- Font Card Installation, 103
- Font Specifications, 87
- Front Panel
  - Display, 24
  - Keys, 25
  - Lights, 26
- Fuse Replacement, 68

## G

- General Specifications, 85

## I

- Inspection, 1
- Interconnections
  - RS-232, 98–100
  - RS-422, 101
  - RS-485, 101
- Interfaces, 21

## L

- Label Backing Material Removal, 36
- Loading the Media
  - Cutter Mode, 32
  - Peel-Off Mode, 28
  - Peel-Only Mode, 33
  - Rewind Mode, 30
  - Tear-Off Mode, 27
- Lubrication, 68

## M

- Media
  - Calibration, 17
  - Requirements, 2
  - Specifications, 88
- Media Loading
  - Cutter Mode, 32
  - Peel-Off Mode, 28
  - Peel-Only Mode, 33
  - Rewind Mode, 30
  - Tear-Off Mode, 27
- Media Sensor Positioning
  - Black Mark Sensor, 12
  - Transmissive Sensor, 10
- Media Types
  - Continuous Media, 7
  - Non-Continuous Black Mark Media, 7
  - Non-Continuous Web Media, 6
- Memory Card Installation, 103

## N

- Non-Continuous Black Mark Media, 7
- Non-Continuous Web Media, 6

## O

- Operator Controls
  - Front Panel Display, 24
  - Front Panel Keys, 25
  - Front Panel Lights, 26
  - POWER Switch, 14, 23
- Options, 83

## P

- Parallel Data Port, 102
- Password-Protected Parameters, 42
- PAUSE Key Self Test, 79
- PCMCIA Card Installation, 103
- Peel-Off Mode, 28
- Peel-Only Mode, 33
- Power Cord, 3
- Power Line Cord Specifications, 89
- POWER Switch, 14, 23
- Power-On Self Test, 77
- Print Modes, 8
- Printer Anatomy Overview, 4
- Printer Diagnostics, 77–81
- Printing Specifications, 86

## R

- Reporting Damage, 1
- Rewind Mode, 30
- Ribbon
  - Calibration, 17
  - Requirements, 2
  - Specifications, 86
- Ribbon Loading, 13, 37
- Ribbon Removal, 39
- RS-232 Serial Data Port, 97

## S

- Self Tests
  - Additional Printer Self Tests, 77
  - CANCEL Key, 78
  - Communications Diagnostics, 81
  - FEED Key and PAUSE Key, 81
  - FEED Key, 80
  - PAUSE Key, 79
  - Power-On, 77
- Serial Data Port, 97–101
- Setup Mode (Configuration)
  - Entering, 41
  - Leaving, 43

## Specifications

- Bar Codes, 84
- Font, 87
- General, 85
- Media Handling, 83
- Media, 88
- Options, 83
- Power Line Cord, 89
- Printing, 86
- Ribbon, 86
- ZPL Programming Language, 84

## Storage, 2

## **T**

- Tear-Off Mode, 27
- Test Label Printing, 19
- Transmissive Sensor Adjustment, 10
- Troubleshooting
  - Communications, 75–76
  - LED Error Conditions and Warnings, 71–73
  - Print Quality Problems, 74
  - Wrinkled Ribbon, 75
- Types of Media
  - Continuous, 7
  - Non-Continuous Black Mark, 7
  - Non-Continuous Web, 6

## **U**

- Unpacking, 1

## **W**

- Warranty Information, 91

## **Z**

- ZPL Programming Language, 84



## Free Manuals Download Website

<http://myh66.com>

<http://usermanuals.us>

<http://www.somanuals.com>

<http://www.4manuals.cc>

<http://www.manual-lib.com>

<http://www.404manual.com>

<http://www.luxmanual.com>

<http://aubethermostatmanual.com>

Golf course search by state

<http://golfingnear.com>

Email search by domain

<http://emailbydomain.com>

Auto manuals search

<http://auto.somanuals.com>

TV manuals search

<http://tv.somanuals.com>