

Bradyprinter™ X-Plus II

User Guide

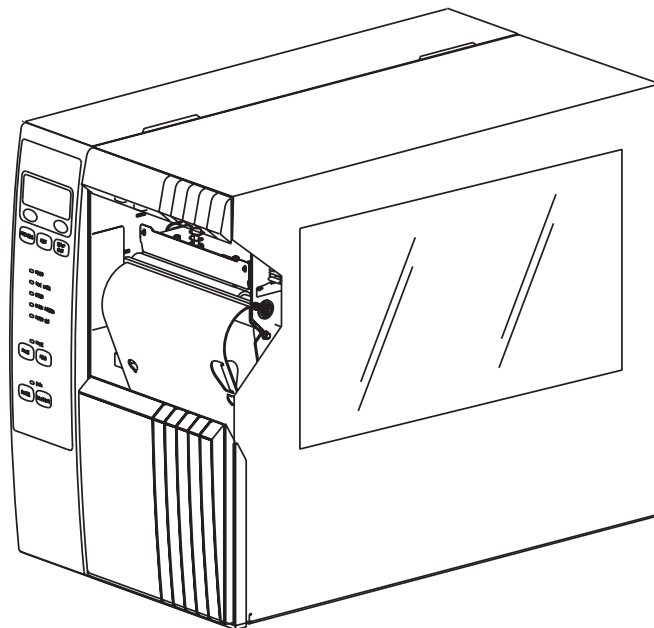

© 2007 Brady Corp. The copyrights in this manual and the software and/or firmware in the label printer described therein are owned by Brady Corp. Unauthorized reproduction of this manual or the software and/or firmware in the label printer may result in imprisonment of up to one year and fines of up to \$10,000 (17 U.S.C.506). Copyright violators may be subject to civil liability.

The Brady logo is a registered trademark of Brady Corporation. All rights reserved worldwide.

This product may contain ZPL[®], ZPL II[®], and ZebraLink[™] programs; Element Energy Equalizer[®] Circuit; E³[®]; and Monotype Imaging fonts. Software © ZIH Corp. All rights reserved worldwide.

ZebraLink and all product names and numbers are trademarks, and Zebra, the Zebra logo, ZPL, ZPL II, Element Energy Equalizer Circuit, and E³ Circuit are registered trademarks of ZIH Corp. All rights reserved worldwide.

All other brand names, product names, or trademarks belong to their respective holders.

Proprietary Statement This manual contains proprietary information of Brady Corporation. It is intended solely for the information and use of parties operating and maintaining the equipment described herein. Such proprietary information may not be used, reproduced, or disclosed to any other parties for any other purpose without the express, written permission of Brady Corporation.

Product Improvements Continuous improvement of products is a policy of Brady Corporation. All specifications and designs are subject to change without notice.

Liability Disclaimer Brady Corporation takes steps to ensure that its published Engineering specifications and manuals are correct; however, errors do occur. Brady Corporation reserves the right to correct any such errors and disclaims liability resulting therefrom.

Limitation of Liability In no event shall Brady Corporation or anyone else involved in the creation, production, or delivery of the accompanying product (including hardware and software) be liable for any damages whatsoever (including, without limitation, consequential damages including loss of business profits, business interruption, or loss of business information) arising out of the use of, the results of use of, or inability to use such product, even if Brady Corporation has been advised of the possibility of such damages. Some jurisdictions do not allow the exclusion or limitation of incidental or consequential damages, so the above limitation or exclusion may not apply to you.

Part Number: 14068L-001 Rev. A



FCC Declaration of Conformity

I have determined that the Brady printers identified as the
Bradyprinter THT 300X-Plus II, 360X-Plus II, and 600X-Plus II

manufactured by:

Zebra Technologies Corporation
333 Corporate Woods Parkway
Vernon Hills, Illinois 60061-3109 U.S.A.

Have been shown to comply with the applicable technical standards of the FCC

For Home, Office, Commercial, and Industrial use

If no unauthorized change is made in the equipment,
and if the equipment is properly maintained and operated.

A handwritten signature in black ink, reading "M. Charles DeSisto", with a horizontal line underneath.

Compliance Information

FCC Compliance Statement

This device complies with Part 15 rules. Operation is subject to the following two conditions:

1. This device may not cause harmful interference, and
2. This device must accept any interference received, including interference that may cause undesired operation.

The user is cautioned that any changes or modifications not expressly approved by Brady Corporation could void the user's authority to operate the equipment. To ensure compliance, this printer must be used with Shielded Communication Cables.

Canadian DOC Compliance Statement

This Class B digital apparatus complies with Canadian ICES-003.

Cet appareil numérique de la classe B est conforme à la norme NMB-003 du Canada.



CE Declaration of Conformity

Brady Corporation declares that the following Information Technology Equipment

Bradyprinter THT 300X-Plus II, 360X-Plus II, and 600X-Plus II

Complies with following applicable directives and standards for the ITE: Residential, Commercial, and Light Industry environments

Applicable Directives and Supporting Standards:

89/336/EEC EMC Directive, EN55022:1998 Class B, EN55024:1998
73/23/EEC LVD Directive, EN60950:2000, CB Scheme

Other supporting files:

FCC Part 15, Subpart B, Class B, FCC Part 15.247, IC RSS-210

NOM 019-SCFI-1998
C-TICK

Manufactured by: Zebra Technologies Corporation
333 Corporate Woods Parkway
Vernon Hills, Illinois 60061-3109 U.S.A.

I, the undersigned, declare that the equipment specified conforms to all Directives and Standards listed above, effective as of the date below.

A handwritten signature in black ink, appearing to read "Mr. Charles A. Derrow".

Mr. Charles A. Derrow
Manager, Compliance Eng
Zebra Technologies Corporation
333 Corporate Woods Parkway
Vernon Hills, IL 60083

A handwritten signature in black ink, appearing to read "Rod Rodericks".

Rod Rodericks
Managing Director Zebra Technologies
Europe Limited Zebra House, The Valley
Center, Gordon Road High Wycombe,
Buckinghamshire HP13 6EQ UK

Effective Date: 10 August 2004



Notes • _____

Contents

FCC Declaration of Conformity	iii
Compliance Information	iv
CE Declaration of Conformity	v
About This Document	1
Who Should Use This Document	2
How This Document Is Organized	2
Contacts	3
United States	3
European Union (EU)	3
Asia Pacific	3
Document Conventions	4
1 • Introduction	7
External View	8
Printer Components	9
Control Panel	10
Control Panel LCD	11
Control Panel Buttons	11
Control Panel Indicator Lights	13
2 • Printer Setup	15
Before You Begin	16
Handling the Printer	17
Unpack and Inspect the Printer	17
Store the Printer	17
Ship the Printer	17
Recycle the Printer	17

Select a Site for the Printer	18
Select a Surface	18
Provide Proper Operating Conditions	18
Allow Proper Space	18
Provide a Data Source	18
Provide a Power Source	18
Select a Communication Interface	19
Connector Locations	19
Types of Connections	20
Data Cable Requirements	23
Connect the Printer to a Power Source	24
Power Cord Specifications	25
Types of Media	26
Ribbon Overview	28
When to Use Ribbon	28
Coated Side of Ribbon	28
3 • Operations	31
Prepare the Media for Loading	32
Print Modes	34
Load Media in Tear-Off Mode	35
Load Ribbon	41
Remove Used Ribbon	46
Calibrate the Printer	48
Adjust Media Sensors	50
Upper Media Sensor—Inside Half of Media	50
Upper Media Sensor—Outside Half of Media	51
Lower Media Sensor	52
Adjust Printhead Pressure and Toggle Position	53
Toggle Position Adjustment	53
Printhead Pressure Adjustment	54
4 • Configuration	57
Setup Mode	58
Enter Setup Mode	58
Exit Setup Mode	59
Change Password-Protected Parameters	60
Default Password Value	60
Disable the Password Protection Feature	60
Print a Configuration Label	61
Print a Network Configuration Label	62

Control Panel Parameters	63
How to View or Modify Parameters	63
Additional Parameters	63
Standard Printer Parameters	63
5 • Print Modes	91
Print Modes	92
Select the Print Mode	92
Tear-Off Mode	92
Load Media in Peel-Off Mode	93
Load Media in Cutter Mode	100
Load Media in Rewind Mode (No Cutter)	105
Load Media in Rewind Mode with Cutter Option	112
Install the Rewind Plate	119
Remove Media Liner from the Rewind or Peel Spindle	120
6 • Routine Maintenance	123
Cleaning Schedule	124
Clean the Exterior	125
Clean the Media Compartment	125
Clean the Printhead and Platen Roller	125
Clean the Sensors	128
Ribbon and Label-Available Sensor Locations	128
Transmissive (Media) Sensor Locations	130
Clean the Snap Plate	131
Clean the Cutter	133
Replace the Fuse (360X-Plus II Only)	134
7 • Troubleshooting	137
Troubleshooting Checklists	138
LCD Error Messages	139
Print Quality Problems	143
Calibration Problems	146
Communications Problems	147
Ribbon Problems	148
Miscellaneous Printer Problems	149

Printer Diagnostics	151
Power-On Self Test.	151
CANCEL Self Test	152
PAUSE Self Test.	153
FEED Self Test.	154
FEED and PAUSE Self Test	158
Communications Diagnostics Test	159
Sensor Profile.	160
8 • Data Ports	161
Parallel Data Port	162
Parallel Cabling Requirements	162
Parallel Port Interconnections.	162
Serial Data Port.	164
Hardware Control Signal Descriptions	164
Pin Configuration	165
RS-232 Interface Connections	166
Applicator Interface Connector	168
Applicator Signals.	168
Applicator Interface Connector Pin Configuration.	170
Jumper Configurations and Pinouts for +5 V I/O Operation	173
Pinouts for +24-28 V I/O Operation	174
9 • Specifications	175
Features	176
Standard Features	176
Print Modes.	176
Zebra Programming Language (ZPL).	176
Bar Codes.	177
Agency Approvals.	178
General Specifications	179
Physical Specifications	179
Electrical Specifications	179
Environmental Conditions for Operation and Storage	179
Print Specifications by Model	180
Ribbon Specifications	181
Media Specifications.	182
BP-300X-Plus II and 600 X-Plus II Printers	182
BP-360X-Plus II Printers.	183
Glossary	185
Index	189

About This Document

This section provides you with contact information, document structure and organization, and additional reference documents.

Contents

Who Should Use This Document	2
How This Document Is Organized	2
Contacts	3
United States	3
European Union (EU).	3
Asia Pacific	3
Document Conventions	4

Who Should Use This Document

This User Guide is intended for use by any person who needs to perform routine maintenance, upgrade, or troubleshoot problems with the printer.

How This Document Is Organized

The User Guide is set up as follows:

Section	Description
<i>Introduction on page 7</i>	This section provides a high-level overview of the printer and its components.
<i>Printer Setup on page 15</i>	This section provides the tasks that you must complete and the issues that you must consider before you load and configure your printer.
<i>Operations on page 31</i>	This section provides the procedures for loading and calibrating the printer.
<i>Configuration on page 57</i>	This section describes the control panel parameters that are used to configure the printer for operation.
<i>Print Modes on page 91</i>	This section describes the print mode options available for the printer.
<i>Routine Maintenance on page 123</i>	This section provides routine cleaning and maintenance procedures.
<i>Troubleshooting on page 137</i>	This section provides information about errors that you might need to troubleshoot. Assorted diagnostic tests are included.
<i>Data Ports on page 161</i>	This section describes the standard communication ports available to connect the printer to your computer or network.
<i>Specifications on page 175</i>	This section provides the features of and specifications for this printer.
<i>Glossary on page 185</i>	The glossary provides a list of common terms.

Contacts

You can contact Brady Corporation at the following:

United States

Brady Worldwide Identification Solutions
6555 West Good Hope Road
P.O. Box 2131
Milwaukee, WI 53201-2131

<http://www.bradyid.com>

Telephone: +1.800.537.8791

Fax: +1 800.292.2289

European Union (EU)

W.H.Brady n.v.
Industriepark C3
Lindestraat 20
B-9240 Zele
Belgium

<http://www.bradyeurope.com>

Telephone: 32 (0) 52 457 811

Fax: 32 (0) 52 457 812

Asia Pacific

Brady Corporation Asia Pte Ltd
1 Kaki Bukit Crescent
Singapore 416236

<http://www.bradyid.com.sg>

Telephone: 65-6477-7261

Fax: 65-6383-2229

Document Conventions

The following conventions are used throughout this document to convey certain information.

Alternate Color (online only) Cross-references contain hot links to other sections in this guide. If you are viewing this guide online in .pdf format, you can click the cross-reference ([blue text](#)) to jump directly to its location.

LCD Display Examples Text from a printer's Liquid Crystal Display (LCD) appears in **Bubbledot ICG** font.

Command Line Examples Command line examples appear in `Courier New` font. For example, type `ZTools` to get to the Post-Install scripts in the `bin` directory.

Files and Directories File names and directories appear in `Courier New` font. For example, the `Brady<version number>.tar` file and the `/root` directory.

Icons Used



Caution • Warns you of the potential for electrostatic discharge.



Caution • Warns you of a potential electric shock situation.



Caution • Warns you of a situation where excessive heat could cause a burn.



Caution • Advises you that failure to take or avoid a specific action could result in physical harm to you.

Caution • (No icon) Advises you that failure to take or avoid a specific action could result in physical harm to the hardware.



Important • Advises you of information that is essential to complete a task.



Note • Indicates neutral or positive information that emphasizes or supplements important points of the main text.



Example • Provides an example, often a scenario, to better clarify a section of text.

Illustration Callouts Callouts are used when an illustration contains information that needs to be labeled and described. A table that contains the labels and descriptions follows the graphic. [Figure 1](#) provides an example.

Figure 1 • Sample Figure with Callouts

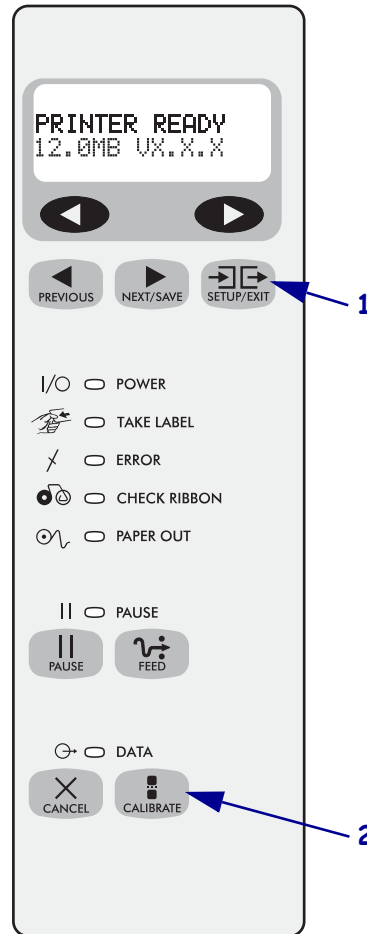

1	SETUP/EXIT button
2	CALIBRATE button



Notes • _____

Introduction

This section provides a high-level overview of the printer and its components.

Contents

External View	8
Printer Components	9
Control Panel	10
Control Panel LCD	11
Control Panel Buttons	11
Control Panel Indicator Lights	13

External View

Figure 2 shows the outside of the printer.

Figure 2 • Exterior of Printer

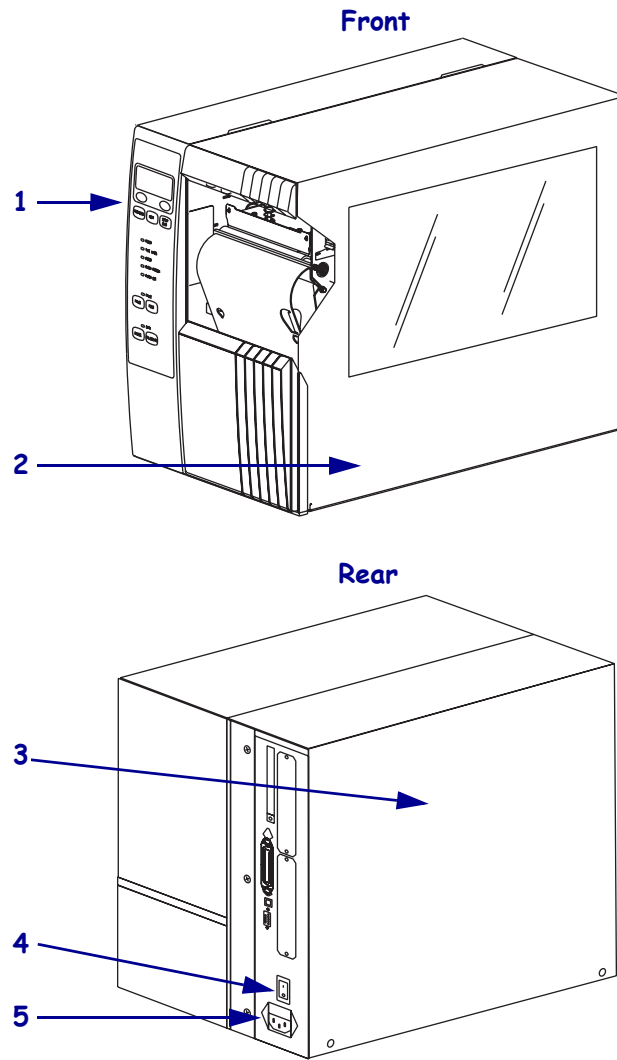

1	Control panel
2	Media door
3	Electronics cover
4	Power switch (O = Off, I = On)
5	AC power connector

Printer Components

Figure 3 shows the components inside the media compartment of your printer. Depending on installed options, your printer may look slightly different.

Figure 3 • Printer Components

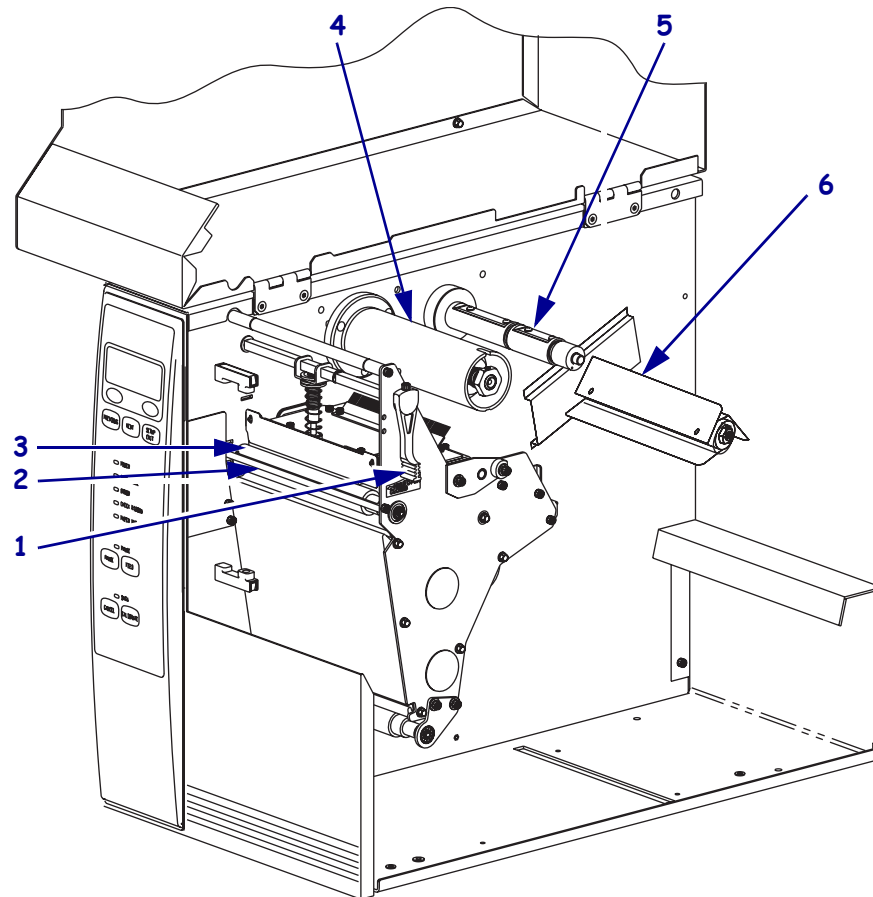

1	Printhead-open lever
2	Peel-off/tear-off bar
3	Platen roller
4	Ribbon take-up spindle
5	Ribbon supply spindle
6	Media supply spindle

Control Panel

All controls and indicators for the printer are located on the control panel (Figure 4).

- The **control panel Liquid Crystal Display (LCD)** shows the operating status and printer parameters.
- The **control panel buttons** are used to control the printer operations and to set parameters.
- The **control panel lights (LEDs)** show the printer's operating status or indicate which control panel buttons are active.

Figure 4 • Location of Control Panel Buttons and Lights

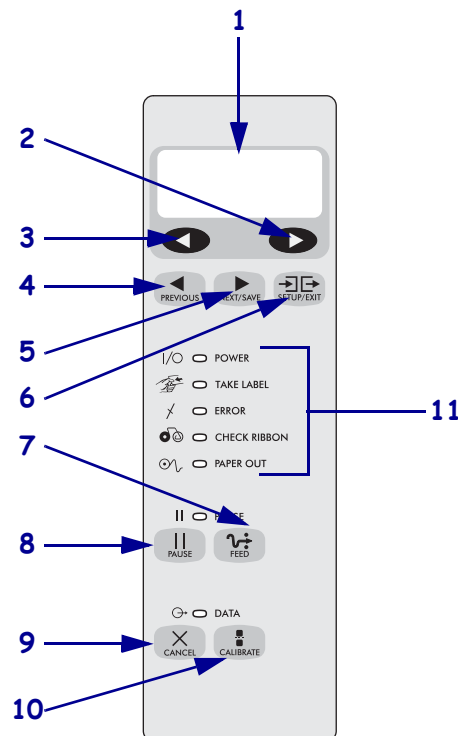

1	LCD
2	PLUS button
3	MINUS button
4	PREVIOUS button
5	NEXT/SAVE button
6	SETUP/EXIT button
7	FEED button
8	PAUSE button
9	CANCEL button
10	CALIBRATE button
11	Indicator lights

Control Panel LCD

The control panel LCD functions differently in different printer modes.

- In **Operating mode**, the LCD displays the printer's status, sometimes in conjunction with a control panel light (see [Control Panel Indicator Lights on page 13](#)).
- In **Pause mode**, the printer stops printing temporarily.
- In **Setup mode**, you can use the control panel LCD to view or modify printer parameters (see [Control Panel Parameters on page 63](#)).
- In **Error mode**, the LCD may display an alert or error message (see [LCD Error Messages on page 139](#)).

Control Panel Buttons

Table 1 describes the function of each button.

Table 1 • Control Panel Buttons









Button	Appearance	Function
PAUSE		Stops and restarts the printing process or removes error messages and clears the LCD. <ul style="list-style-type: none"> • If the printer is idle, it enters Pause mode immediately. • If the printer is printing, the label is completed before the printer pauses.
FEED		Advances a blank label. <ul style="list-style-type: none"> • If the printer is idle or paused, the label is fed immediately. • If the printer is printing, the label is fed after printing finishes.
CANCEL		CANCEL functions only in Pause mode. Pressing CANCEL once has these effects: <ul style="list-style-type: none"> • Cancels the label format that is currently printing. • If no label format is printing, the next one to be printed is canceled. • If no label formats are waiting to be printed, CANCEL is ignored. To clear the printer's entire label format memory, press and hold CANCEL. When the formats are cleared, the DATA light turns off.
CALIBRATE		Calibrates the printer for the following: <ul style="list-style-type: none"> • Media length • Media type (continuous or non-continuous) • Print mode (direct thermal or thermal transfer) • Sensor values For more information on calibration, see Calibrate the Printer on page 48 .
SETUP/EXIT		Enters and exits Setup mode.
PREVIOUS		When in Setup mode, scrolls the LCD to the previous parameter. Press and hold to scroll quickly.

Table 1 • Control Panel Buttons (Continued)

Button	Appearance	Function
NEXT/SAVE		<ul style="list-style-type: none"> • When in Setup mode, scrolls the LCD to the next parameter. Press and hold to scroll quickly. • When exiting Setup mode, saves any changes you have made in the configuration and calibration sequence.
LEFT OVAL		<p>Changes the parameter values. Common uses are to decrease a value, to answer “no,” to scroll through choices, or to change the cursor position while entering the password.</p>
RIGHT OVAL		<p>Changes the parameter values. Common uses are to increase a value, to answer “yes,” to scroll through choices, or to change values while entering the password.</p>







Control Panel Indicator Lights

Table 2 describes lights on the control panel that indicate different printer conditions.



Note • If two operating conditions occur simultaneously (for example, one that causes a light to be on constantly and one that causes the same light to flash), the indicator light flashes.

Table 2 • Control Panel Indicator Lights

Light	Appearance	Status	Indication
POWER		Off	The printer is off or power is not applied.
		On	The printer is on.
TAKE LABEL		Off	Normal operation.
		Flashing	(Peel mode only.) The label is available. Printing pauses until the label is removed.
ERROR		Off	Normal operation—no printer errors.
		Flashing	A printer error exists. Check the LCD for more information.
CHECK RIBBON		Off	Normal operation—ribbon (if used) is properly loaded.
		On	Printing is paused, the LCD displays a warning message, and the PAUSE light is on. <ul style="list-style-type: none"> If the printer is in Direct Thermal Mode: ribbon is loaded. If the printer is in Thermal Transfer Mode: no ribbon is loaded.
PAPER OUT		Off	Normal operation—media is properly loaded.
		On	No media is under the media sensor. Printing is paused, the LCD shows an error message, and the PAUSE light is on.
PAUSE		Off	Normal operation.
		On	The printer stopped all printing operations. Causes include: <ul style="list-style-type: none"> PAUSE was pressed A label format included a pause command The online verifier detected an error A printer error was detected. The LCD gives additional information.
DATA		Off	Normal operation. No data being received or processed.
		On	The printer is processing data or is printing. No data is being received.
		Flashing	The printer is receiving data from or sending status information to the host computer.



Notes • _____

Printer Setup

This section provides the tasks that you must complete and the issues that you must consider before you load and configure your printer.

Contents

Before You Begin	16
Handling the Printer	17
Unpack and Inspect the Printer	17
Store the Printer	17
Ship the Printer	17
Recycle the Printer	17
Select a Site for the Printer	18
Select a Surface	18
Provide Proper Operating Conditions	18
Allow Proper Space	18
Provide a Data Source	18
Provide a Power Source	18
Select a Communication Interface	19
Connector Locations	19
Types of Connections	20
Data Cable Requirements	23
Connect the Printer to a Power Source	24
Power Cord Specifications	25
Types of Media	26
Ribbon Overview	28
When to Use Ribbon	28
Coated Side of Ribbon	28

Before You Begin

Review this checklist, and resolve any issues before you set up or use your printer.

- Unpack and Inspect the Printer** Have you unpacked the printer and inspected it for damage? If you have not, see [Unpack and Inspect the Printer on page 17](#).
- Select a Site** Have you selected an appropriate location for the printer? If you have not, see [Select a Site for the Printer on page 18](#).
- Connect to a Data Source** Have you determined how the printer will connect to a data source (usually a computer)? For more information, see [Select a Communication Interface on page 19](#).
- Attach a Power Cord** Do you have the correct power cord for your printer? If you are unsure, see [Power Cord Specifications on page 25](#). To attach the power cord and connect the printer to a power source, see [Connect the Printer to a Power Source on page 24](#).
- Select Media** Do you have the correct media for your application? If you are unsure, see [Types of Media on page 26](#).
- Select Ribbon** Do you need to use ribbon, and is the appropriate ribbon available, if needed? If you are unsure, see [Ribbon Overview on page 28](#).

Handling the Printer

This section describes how to handle your printer.

Unpack and Inspect the Printer

When you receive the printer, immediately unpack it and inspect for shipping damage.

- Save all packing materials.
- Check all exterior surfaces for damage.
- Raise the media door, and inspect the media compartment for damage to components.

If you discover shipping damage upon inspection:

- Immediately notify the shipping company and file a damage report.
- Keep all packaging material for shipping company inspection.
- Notify your authorized Brady distributor.



Important • Brady Corporation is not responsible for any damage incurred during the shipment of the equipment and will not repair this damage under warranty.

Store the Printer

If you are not placing the printer into immediate operation, repackage it using the original packing materials. You may store the printer under the conditions shown in [Table 3](#).

Table 3 • Storage Temperature and Humidity

Temperature	Relative Humidity
-40°F to 140°F (-40° to 60°C)	5% to 85% non-condensing

Ship the Printer

If you must ship the printer:

- Remove any media or ribbon from the printer to avoid damaging the printer.
- Carefully pack the printer into the original container or a suitable alternate container to avoid damage during transit. A shipping container can be purchased from Brady if the original packaging has been lost or destroyed.

Recycle the Printer



This printer is recyclable. If you must dispose of the printer, do not do so in unsorted municipal waste. Please recycle according to your local standards.

Select a Site for the Printer

Consider the following when selecting an appropriate location for your printer.

Select a Surface

Select a solid, level surface of sufficient size and strength to accommodate the printer and other equipment (such as a computer), if necessary. The choices include a table, countertop, desk, or cart. For the printer's weight and dimensions, see [General Specifications on page 179](#).

Provide Proper Operating Conditions

This printer is designed to function in a wide range of environmental and electrical conditions, including a warehouse or factory floor. For more information on the required conditions, see [General Specifications on page 179](#).

Table 4 shows the temperature and relative humidity requirements for the printer when it is operating.

Table 4 • Operating Temperature and Humidity

Mode	Temperature	Relative Humidity
Thermal Transfer	41° to 104°F (5° to 40°C)	20 to 85% non-condensing
Direct Thermal	32° to 104°F (0° to 40°C)	20 to 85% non-condensing

Allow Proper Space

The printer should have enough space around it for you to be able to open the media door. To allow for proper ventilation and cooling, leave open space on all sides of the printer.



Caution • Do not place any padding or cushioning material behind or under the printer because this restricts air flow and could cause the printer to overheat.

Provide a Data Source

If the printer will be located away from the data source (such as a computer), the selected site must provide the appropriate connections to that data source. For more information on the types of communication interfaces and their limitations, see [Select a Communication Interface on page 19](#).

Provide a Power Source

Place the printer within a short distance of a power outlet that is easily accessible.

Select a Communication Interface

The way that you connect your printer to a data source depends on the communication options installed in the printer. You may use any available connection to send commands and label formats from a host computer to the printer.

Caution • Ensure that the printer power is off (O) before connecting data communications cables. Connecting a data communications cable while the power is on (I) may damage the printer.



Note • You must supply all interface cables or wireless cards for your application. Refer to *Data Cable Requirements* on page 23 for specific cable requirements.

Connector Locations

Refer to [Figure 5](#). The printer comes standard with an Electronics Industries Association (EIA) RS-232 serial interface (DB-9 connector), an IEEE 1284 bidirectional parallel interface, and a USB 2.0-compatible interface. An optional Ethernet port may also be included. You may use any of these interface methods to send commands and label formats from a computer to the printer.

Figure 5 • Cable Connections

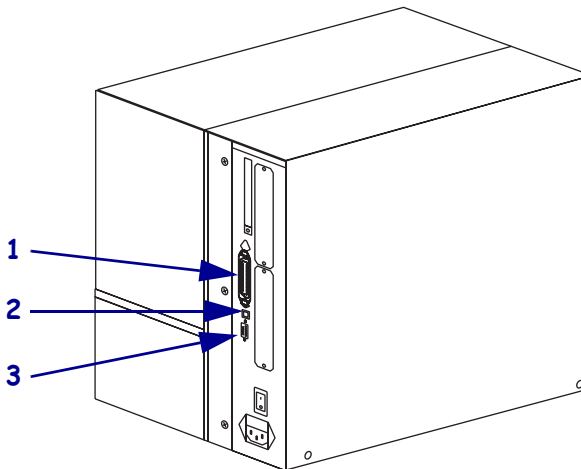

1	Parallel interface connector
2	USB 2.0 connector
3	DB-9 serial interface connector

Types of Connections

The method of connecting the printer to a data source depends on the communication options installed in the printer and the host computer. This section provides basic information about common interfaces.

When communicating via the serial data port (RS-232), the baud rate, number of data and stop bits, the parity, and the XON/XOFF or DTR control should be set to match those of the host computer. See [Table 9, Printer Parameters on page 64](#) to configure these parameters. When communicating via the parallel port or the USB port, the previously mentioned parameters do not apply.

RS-232 Serial A serial communication method consisting of data and control signals; available as a standard feature on most personal computers and other hosts.

- *Advantages:* Cables and connectors are readily available from computer equipment stores and suppliers; easy to connect; two-way communication between the computer and the printer; relatively long cable length.
- *Disadvantages:* Slower than the parallel connection; limited to 50 feet (15.24 m) of cable; may need to change printer parameters to match host computer; need to use a null-modem adaptor to connect to the printer if using a standard modem cable.

Figure 6 • Connecting the Printer through the Serial Data Port

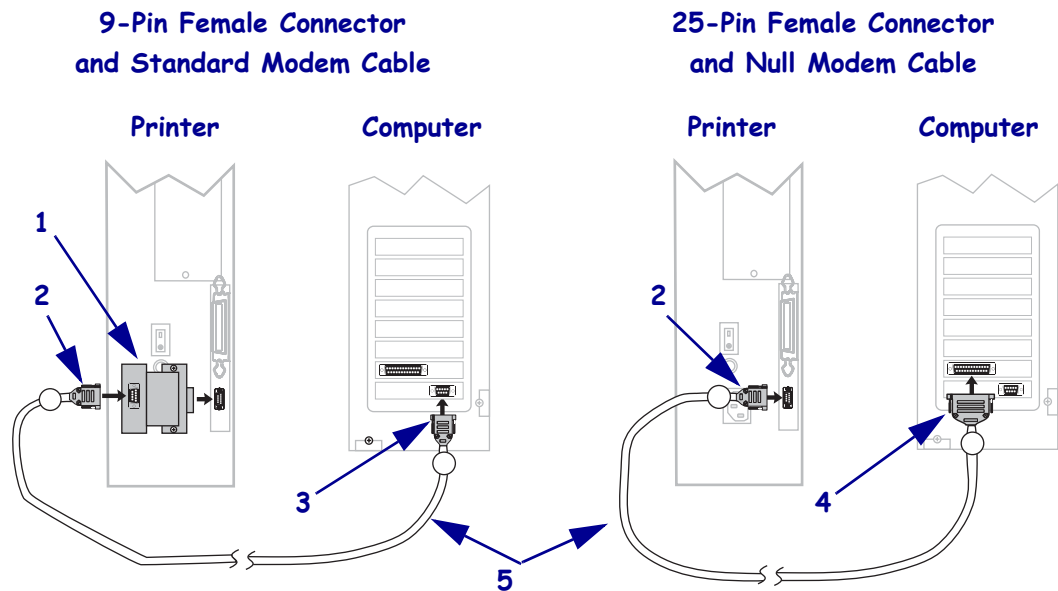

1	Null-modem adaptor (if using a standard modem cable)
2	9-pin male connector, connected to printer or null-modem adaptor
3	9-pin female connector, connected to computer
4	25-pin female connector, connected to computer
5	Maximum cable length = 50 ft. (15 m)

IEEE 1284 Bidirectional Parallel A common communication method available on most personal computers and other hosts.

- *Advantages:* Faster than the serial connection; cables and connectors are readily available from computer equipment stores and suppliers; easy to connect; two-way communication between the computer and the printer; no printer parameter changes required to match the host computer.
- *Disadvantages:* Recommended cable length of only 6 feet (1.83 m) with a maximum length of 10 ft (3 m); many computers are equipped with only one parallel port, allowing only one IEEE 1284 bidirectional device to be connected at a time; an Ethernet print server takes up or covers this port on the printer.

Figure 7 • Connecting the Printer through the Parallel Port

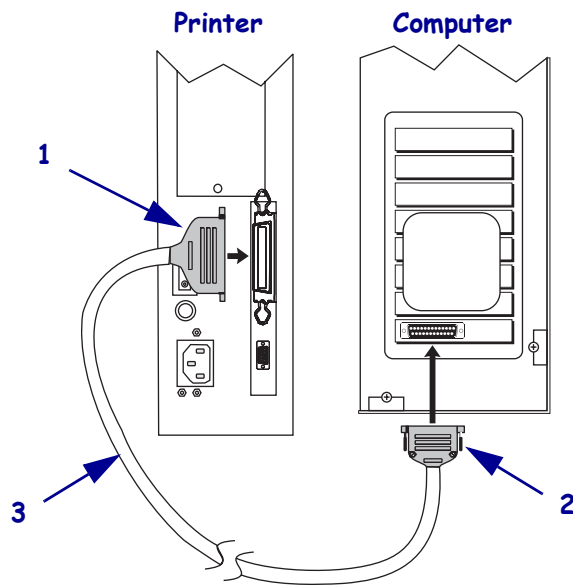

1	36-pin male connector, attaching to printer
2	25-pin male connector, attaching to computer
3	Maximum cable length = 10 ft. (3 m)

USB 2.0 Port Communicating using the USB port (see [Figure 8](#)) does not require special settings.

- *Advantages:* Many computers are equipped with more than one USB port, allowing multiple USB devices to be connected at one time; cables and connectors are readily available from computer equipment stores and suppliers; two-way communication between the computer and the printer; easy to connect; no printer parameter changes required to match the host computer.
- *Disadvantages:* Cable length limited to 16.4 ft. (5 m).

Figure 8 • Connecting the Printer through a USB Port

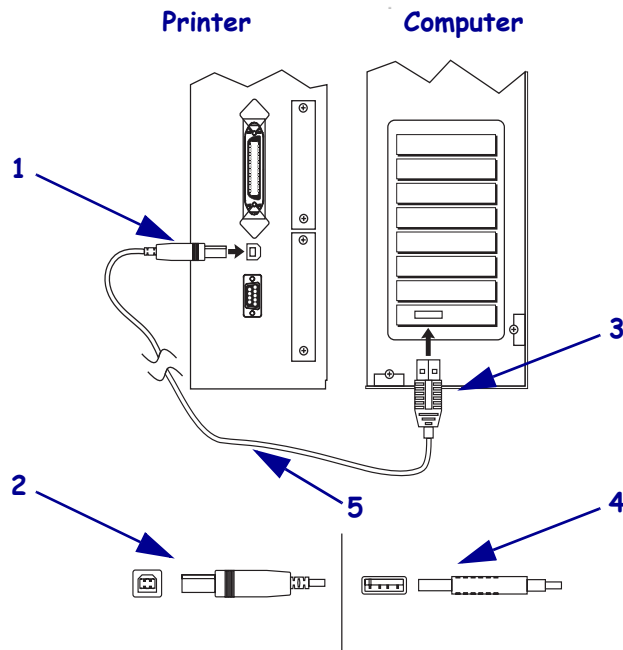

1	“B” male connector, attaching to printer
2	“B” male connector, detail
3	“A” male connector, attaching to computer
4	“A” male connector, detail
5	Maximum cable length = 16.4 ft. (5 m)

Optional Ethernet Print Servers Ethernet-based print servers also are available to connect your printer to a data source. Manuals are available on the user CD that came with your printer.



Note • The parallel connection on your printer is not operational when one of these print server is installed. Wireless and external wired print servers plug directly into the printer’s parallel port. Internal print servers include a mounting bracket that covers the parallel port.

With the BradyConnect PrintServer II (PSII), the printer can communicate with a 10BaseT network. For more information on PSII, see the *PrintServer II User and Reference Guide*.

Data Cable Requirements

Ethernet cables do not require shielding, but all other data cables must be fully shielded and fitted with metal or metallized connector shells. Unshielded data cables may increase radiated emissions above the regulated limits.

To minimize electrical noise pickup in the cable:

- Keep data cables as short as possible.
- Do not bundle the data cables tightly with the power cords.
- Do not tie the data cables to power wire conduits.



Note • Brady printers comply with FCC Rules and Regulations, Part 15 for Class B Equipment using fully shielded, 6.5 ft. (2 m) data cables. Use of unshielded cables may increase radiation above the Class B limits.

Connect the Printer to a Power Source

The AC power cord must have a three-prong female connector on one end that plugs into the mating AC power connector at the rear of the printer. If a power cable was not included with your printer, refer to [Power Cord Specifications](#) on page 25.



Caution • For personnel and equipment safety, always use an approved three-conductor power cord specific to the region or country intended for installation. This cord must use an IEC 320 female connector and the appropriate region-specific three-conductor grounded plug configuration.

To connect the printer to a power source, complete these steps:

1. Toggle the printer power switch to the off (O) position.
2. See [Figure 9](#). Plug the power cord into the AC power connector on the rear of the printer.

Figure 9 • Power Connection

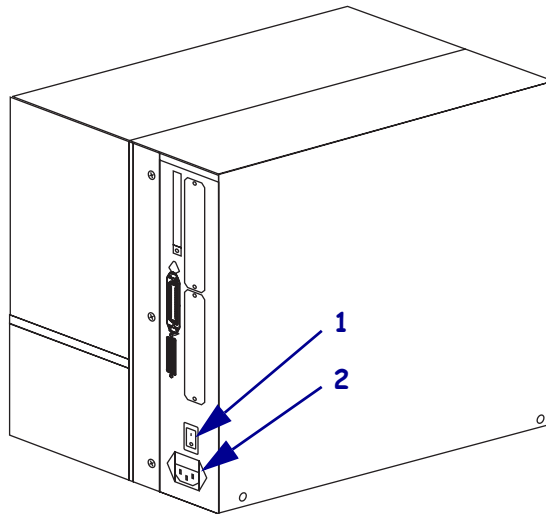

1	Power switch
2	AC power connector

3. Plug the other end of the power cord into a power outlet near the printer.
4. Turn on (I) the printer.
The control panel LCD and lights activate, indicating that the printer is booting up.

Power Cord Specifications



Caution • For personnel and equipment safety, always use an approved three-conductor power cord specific to the region or country intended for installation. This cord must use an IEC 320 female connector and the appropriate region-specific, three-conductor grounded plug configuration.

Depending on how your printer was ordered, a power cord may or may not be included. If one is not included or if the one included is not suitable for your requirements, refer to the following guidelines:

- The overall cord length must be less than 9.8 ft. (3.0 m).
- The cord must be rated for at least 10 A, 250 V.
- The chassis ground (earth) **must** be connected to ensure safety and reduce electromagnetic interference. The third wire in the power cord grounds the connection (Figure 10).

Figure 10 • Power Cord Specifications

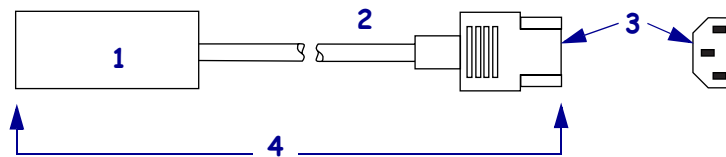

1	AC power plug for your country—This should bear the certification mark of at least one of the known international safety organizations (Figure 11).
2	3-conductor HAR cable or other cable approved for your country.
3	IEC 320 connector—This should bear the certification mark of at least one of the known international safety organizations (Figure 11).
4	Length ≤ 9.8 ft. (3 m). Rating 10 Amp, 250 VAC.

Figure 11 • International Safety Organization Certifications



Types of Media

The printer can use various types of media (Table 5). Brady strongly recommends the use of Brady-brand supplies for continuous high-quality printing. A wide range of paper, polypropylene, polyester, and vinyl stock has been specifically engineered to enhance the printing capabilities of the printer and to prevent premature printhead wear.

Table 5 • Types of Media

Media Type	How It Looks	Description
<p>Non-Continuous Roll Media</p>		<p>Roll media is wound on a 3-in. (76-mm) core. Labels have adhesive backing that sticks them to a liner, and they are separated by gaps, holes, notches, or black marks. Tags are separated by perforations.</p> <p>Figure 12 • Non-Continuous Web Media</p>  <p>Figure 13 • Black Mark Media</p>  <p>Figure 14 • Tag Stock</p> 

Table 5 • Types of Media (Continued)

Media Type	How It Looks	Description
<p>Non-Continuous Fanfold Media</p>		<p>Fanfold media is folded in a zigzag pattern. Fanfold media can have the same label divisions as non-continuous roll media. The divisions would fall on or near the folds.</p>
<p>Continuous Roll Media</p>		<p>Continuous media is wound on a core and is without gaps, holes, notches, or black marks. This allows the image to be printed anywhere on the label. With continuous media, use the transmissive sensor so the printer can detect when the media runs out.</p>

Ribbon Overview

Ribbon is a thin film that is coated on one side with wax, resin, or wax resin, which is transferred to the media during the thermal transfer process. The media determines whether you need to use ribbon and how wide the ribbon must be.

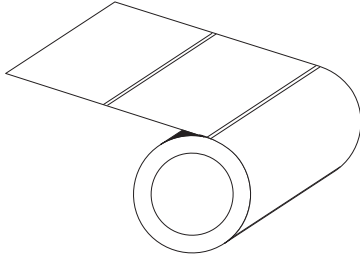
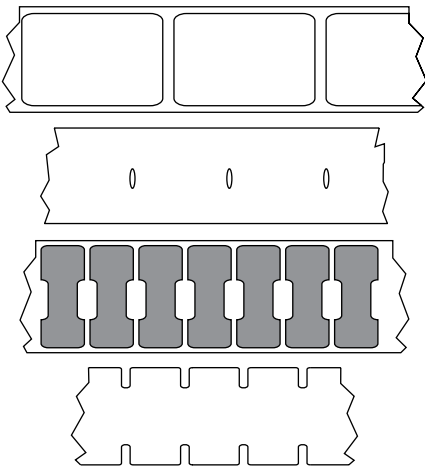
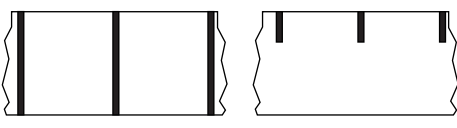
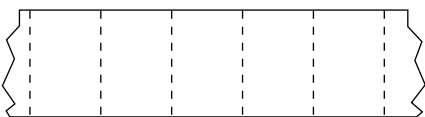
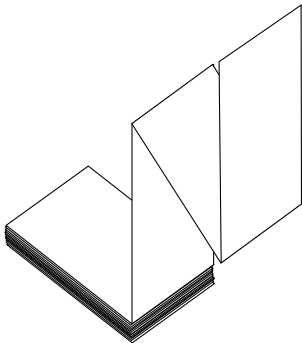
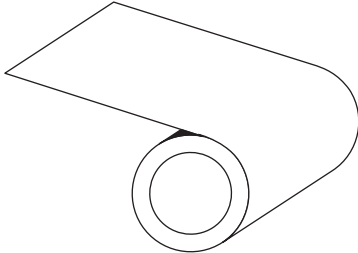
When ribbon is used, it must be as wide as or wider than the media being used. If the ribbon is narrower than the media, areas of the printhead are unprotected and subject to premature wear.

When to Use Ribbon

Thermal transfer media requires ribbon for printing while direct thermal media does not. To determine if ribbon must be used with a particular media, perform a media scratch test.

To perform a media scratch test, complete these steps:

1. Scratch the print surface of the media rapidly with your fingernail.
2. Did a black mark appear on the media?

If a black mark...	Then the media is...
Does not appear on the media	Thermal transfer. A ribbon is required.
Appears on the media	Direct thermal. No ribbon is required.

Coated Side of Ribbon

Ribbon can be wound with the coated side on the inside or outside (Figure 15). This printer can only use ribbon that is coated on the outside. If you are unsure which side of a particular roll of ribbon is coated, perform an adhesive test or a ribbon scratch test to determine which side is coated.

Figure 15 • Ribbon Coated on Outside or Inside



Adhesive Test

If you have labels available, perform the adhesive test to determine which side of a ribbon is coated. This method works well for ribbon that is already installed.

To perform an adhesive test, complete these steps:

1. Peel a label from its liner.
2. Press a corner of the sticky side of the label to the outer surface of the roll of ribbon.
3. Peel the label off of the ribbon.
4. Observe the results. Did flakes or particles of ink from the ribbon adhere to the label?

If ink from the ribbon...	Then...
Adhered to the label	The ribbon is coated on the outer surface.
Did not adhere to the label	The ribbon is coated on the inner surface and cannot be used in this printer. To verify this, repeat the test on the other surface of the roll of ribbon.

Ribbon Scratch Test

Perform the ribbon scratch test when labels are unavailable.

To perform a ribbon scratch test, complete these steps:

1. Unroll a short length of ribbon.
2. Place the unrolled section of ribbon on a piece of paper with the outer surface of the ribbon in contact with the paper.
3. Scratch the inner surface of the unrolled ribbon with your fingernail.
4. Lift the ribbon from the paper.
5. Observe the results. Did the ribbon leave a mark on the paper?

If the ribbon...	Then...
Left a mark on the paper	The ribbon is coated on the outer surface.
Did not leave a mark on the paper	The ribbon is coated on the inner surface and cannot be used in this printer. To verify this, repeat the test on the other surface of the roll of ribbon.



Notes • _____

Operations

This section provides the procedures for loading and calibrating the printer.



Note • Complete the tasks and resolve the issues in [Printer Setup on page 15](#) before operating the printer.

Contents

Prepare the Media for Loading	32
Print Modes	34
Load Media in Tear-Off Mode	35
Load Ribbon	41
Remove Used Ribbon	46
Calibrate the Printer	48
Adjust Media Sensors	50
Upper Media Sensor—Inside Half of Media	50
Upper Media Sensor—Outside Half of Media	51
Lower Media Sensor	52
Adjust Printhead Pressure and Toggle Position	53
Toggle Position Adjustment	53
Printhead Pressure Adjustment	54

Prepare the Media for Loading

You can use roll media or fanfold media in your printer. Roll media hangs on and is loaded from the media supply spindle. Fanfold media is stored away from or in the bottom of the printer and can drape across the media supply spindle.

Roll Media

To place roll media on the media supply hanger, complete these steps:

1. Place the roll of media on the media supply spindle. Push the roll back as far as it will go.

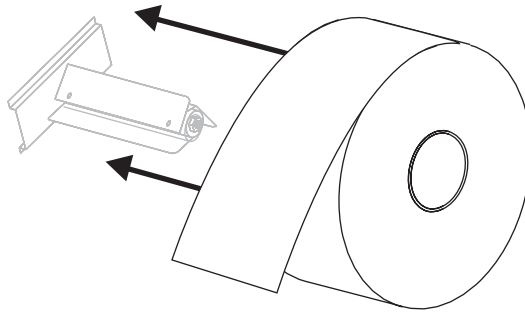

Fanfold Media

You can load fanfold media through the rear access slot or through the bottom access slot. Using the media supply hanger is optional.

Figure 16 • Rear Feed Using Media Supply Hanger

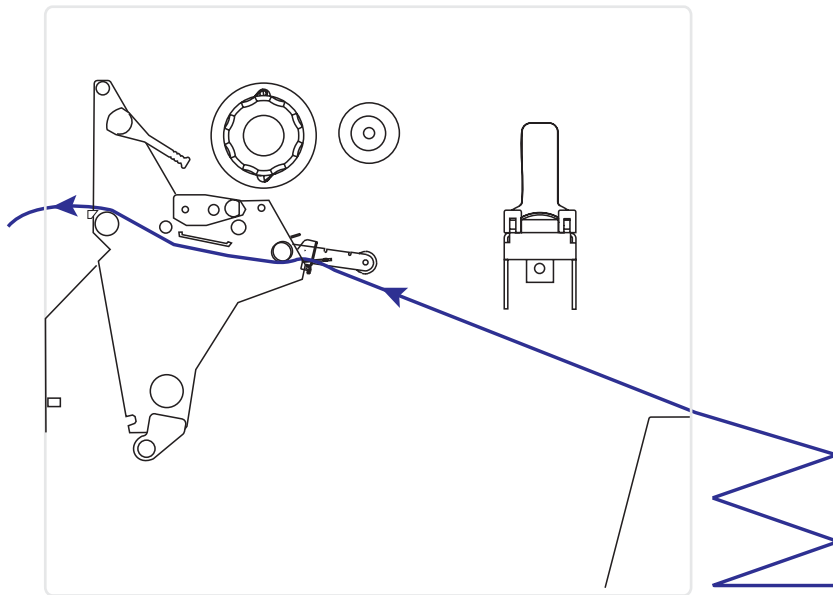
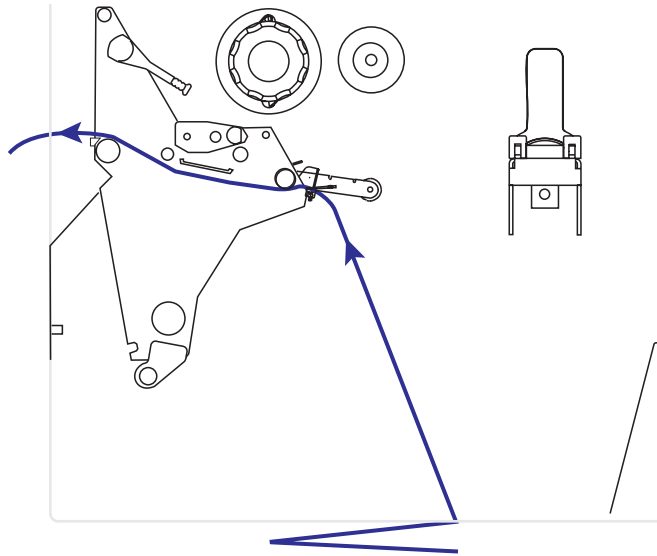
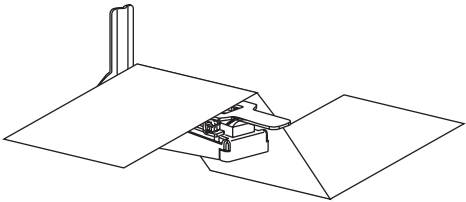
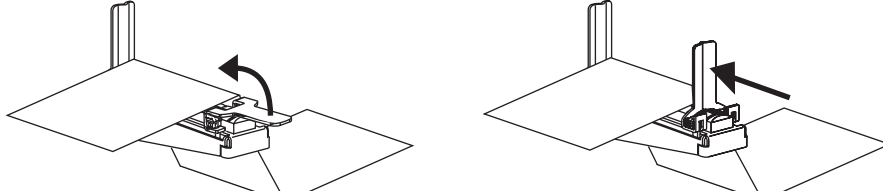

Figure 17 • Bottom Feed Without Using Media Supply Hanger



To load fanfold media, complete these steps:

1. Thread the fanfold media through the rear or bottom access slot.
2. Do you wish to use the media supply guide?

If...	Then...
No	Continue with the media loading procedure for the desired print mode.
Yes	<ol style="list-style-type: none"> a. Slide out and flip down the media supply guide. b. Drape the media over the media supply hanger.
	 <ol style="list-style-type: none"> 3. Flip up the media supply guide, and then slide it in until it touches the edge of the media. 

Print Modes

The printer can print on roll or fanfold media and use different print modes for label removal. Use a print mode that matches the media being used and the printer options available (Table 6). For more information on the types of media, see [Types of Media on page 26](#).

Table 6 • Print Modes

Mode	When to Use	Printer Action
Tear-Off (default setting)	Use for most applications. Can use roll or fanfold media. See Load Media in Tear-Off Mode on page 35 .	Each label or strip of labels can be torn off after printing.
Peel-Off	Use only if printer has the Peel-Off or Rewind option. Usually uses roll media. See Load Media in Peel-Off Mode on page 93 .	The liner is peeled away from the label during printing. When the printed label is removed, the next label prints.
Cutter	Use only if printer has a cutter option. Usually uses roll media. See Load Media in Cutter Mode on page 100 .	The printer automatically cuts the label after it is printed.
Rewind	Use only if printer has the Rewind option without a cutter. Can use roll or fanfold media. See Load Media in Rewind Mode (No Cutter) on page 105 .	The media and/or liner are rewound onto a core as they are printed.
Rewind with Cutter Option	Use only if printer has the Rewind option and a cutter. Can use roll or fanfold media. See Load Media in Rewind Mode with Cutter Option on page 112 .	The media and/or liner are rewound onto a core as they are printed. The labels are not cut.

Load Media in Tear-Off Mode

Tear-Off is the default mode. [Figure 18](#) shows roll media loaded in Tear-Off mode.

Figure 18 • Tear-Off Mode

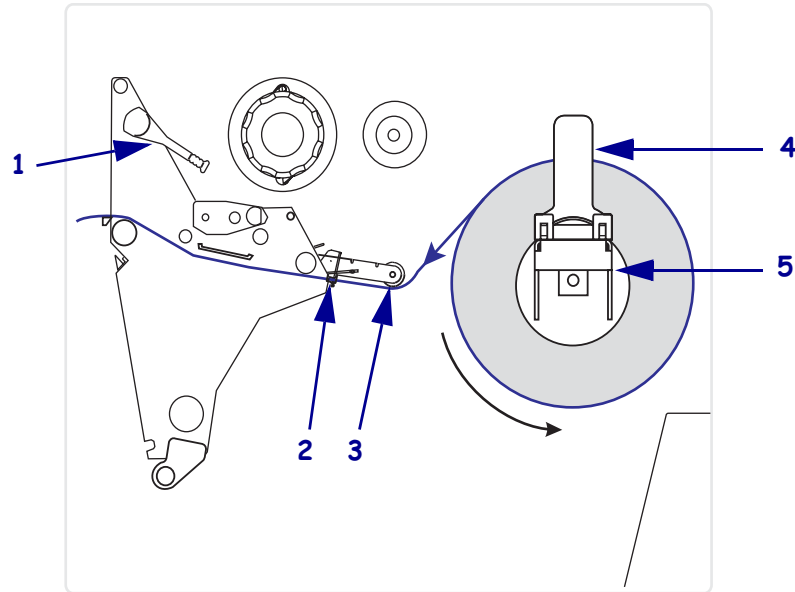

1	Printhead-open lever
2	Media guide
3	Media guide roller
4	Media supply guide
5	Media supply hanger

Caution • While performing any tasks near an open printhead, remove all rings, watches, hanging necklaces, identification badges, or other metallic objects that could touch the printhead. You are not required to turn off the printer power when working near an open printhead, but Brady recommends it as a precaution. If you turn off the power, you will lose all temporary settings, such as label formats, and you must reload them before you resume printing.

To load roll media, complete these steps:

1. Set the printer to Tear-Off mode. See [Select Print Mode on page 65](#) for instructions.
2. Insert media into the printer. See [Prepare the Media for Loading on page 32](#) for instructions.
3. Place the roll of media on the media supply spindle. Push the roll back as far as it will go.

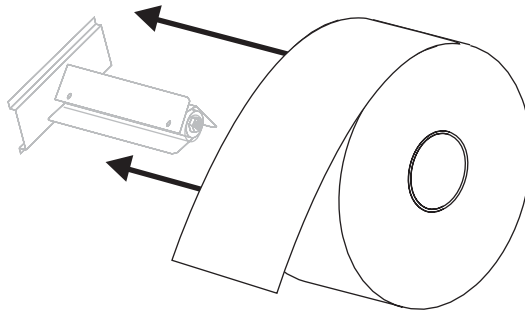

4. Open the printhead assembly by rotating the printhead-open lever (1) counter-clockwise.

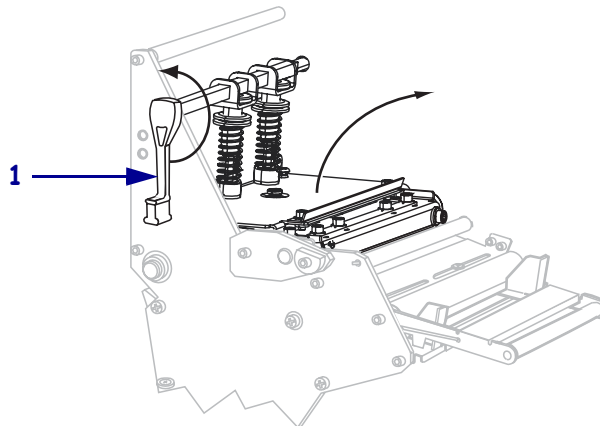

5. Loosen the thumb screw (not visible from this angle) that is located on the bottom of the outer media guide (1).

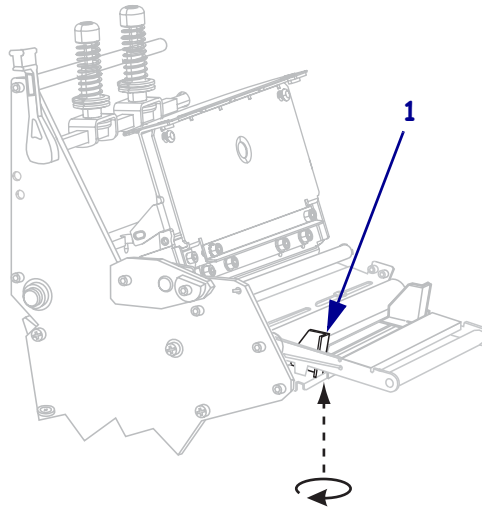

6. Slide the outer media guide (1) all the way out.

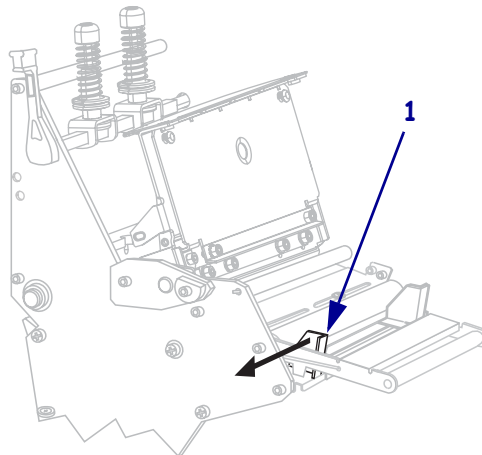

7. If your printer includes a media dancer assembly (1), thread the media under the media dancer assembly roller. For all printers, thread the media under the media guide roller (2) and then the upper media sensor (3).



Important • Make sure that you thread the media under these components. If you thread the media over the them, the media obstructs the ribbon sensor and causes a false **RIBBON OUT** error.

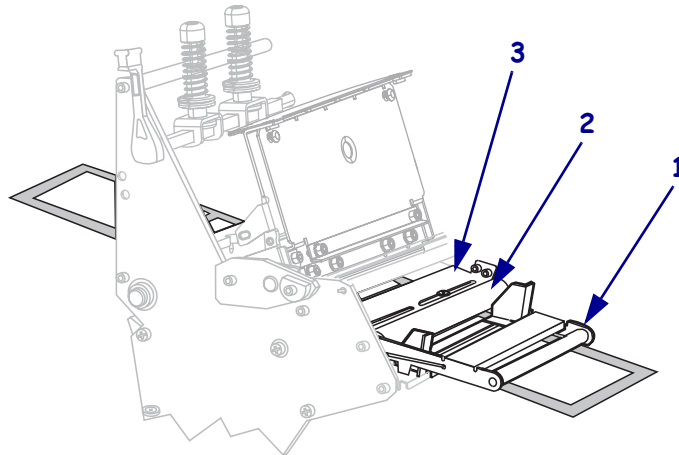

8. Push the media forward until it passes under the printhead assembly (1), under the snap plate (2), and then over the platen roller (3).

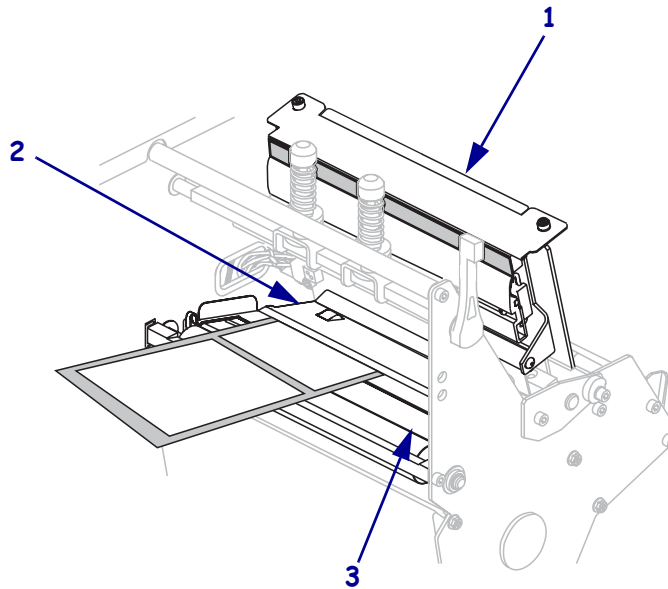

9. Align the media with the inner media guide (1). Slide in the outer media guide (2) until it just touches the edge of the media.

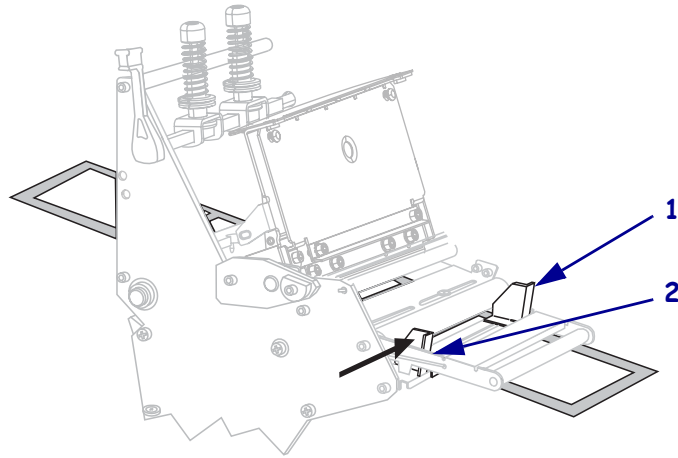

10. Tighten the thumb screw (not visible from this angle) that is located on the bottom of the outer media guide (1).

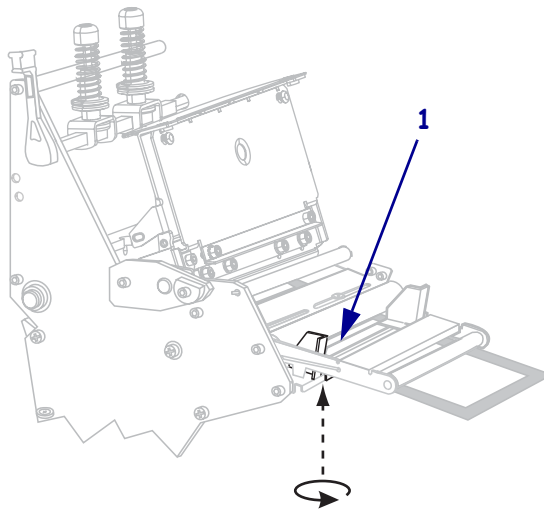

11. Push down the printhead assembly (1), and then rotate the printhead-open lever (2) clockwise until it locks into place.

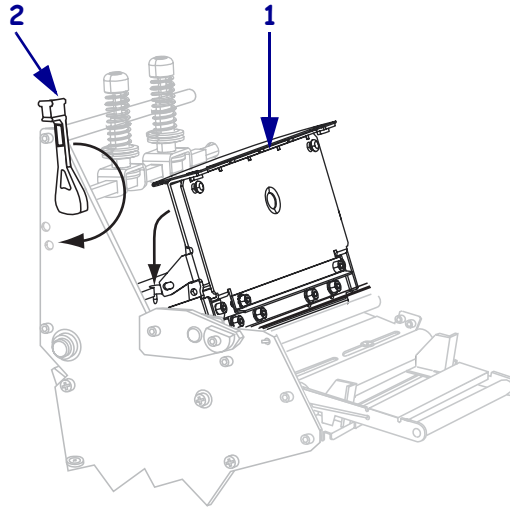

Load Ribbon

Use the instructions in this section to load ribbon for use with thermal transfer labels. For direct thermal labels, do not load ribbon in the printer. The ribbon path is slightly different for printers with ribbon dancers (Figure 19).



Important • Use ribbon that is wider than the media to protect the printhead from wear. Ribbon must be coated on the outside.

Figure 19 • Ribbon Path

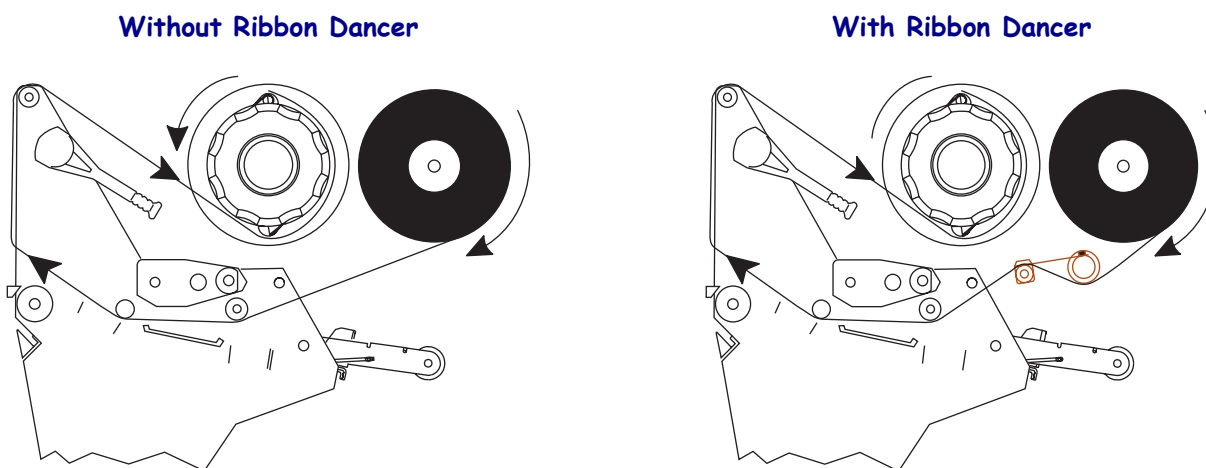

Caution • While performing any tasks near an open printhead, remove all rings, watches, hanging necklaces, identification badges, or other metallic objects that could touch the printhead. You are not required to turn off the printer power when working near an open printhead, but Brady recommends it as a precaution. If you turn off the power, you will lose all temporary settings, such as label formats, and you must reload them before you resume printing.

To load ribbon, complete these steps:

1. Align the arrow (1) on the ribbon take-up spindle knob with the notch (2) in the ribbon take-up spindle.

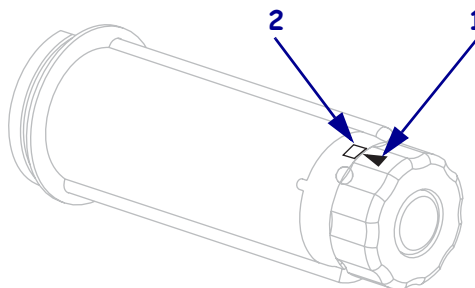

2. Align the segments of the ribbon supply spindle.

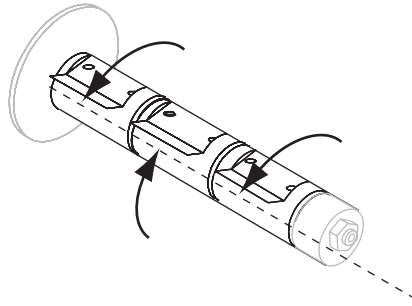

3. Orient the ribbon with the loose end unrolling clockwise.

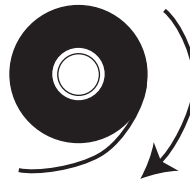

4. Place the roll of ribbon on the ribbon supply spindle. Push the roll back as far as it will go.

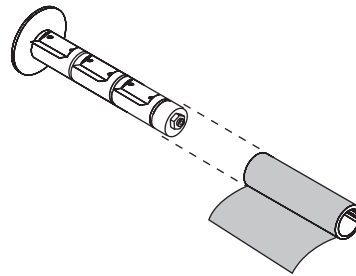

5. A ribbon leader makes ribbon loading and unloading easier. Does your roll of ribbon have paper or something else attached to the end to serve as a ribbon leader?

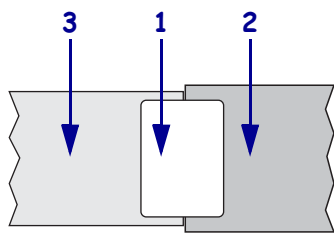
If...	Then...
Yes	Continue with the next step.
No	<p>a. Tear off a strip of media (labels and liner) about 6–12 in. (150–305 mm) long from the roll.</p> <p>b. Peel a label from the media strip.</p> <p>c. Use this label (1) to attach the end of the ribbon (2) to the media strip (3). The media strip acts as a leader.</p> 

6. Open the printhead assembly by rotating the printhead-open lever counter-clockwise.

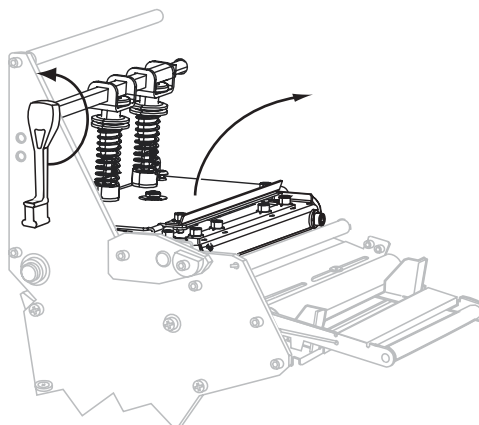

7. Does your printer contain a ribbon dancer assembly? (See [Figure 19 on page 41](#) for the ribbon dancer location.)

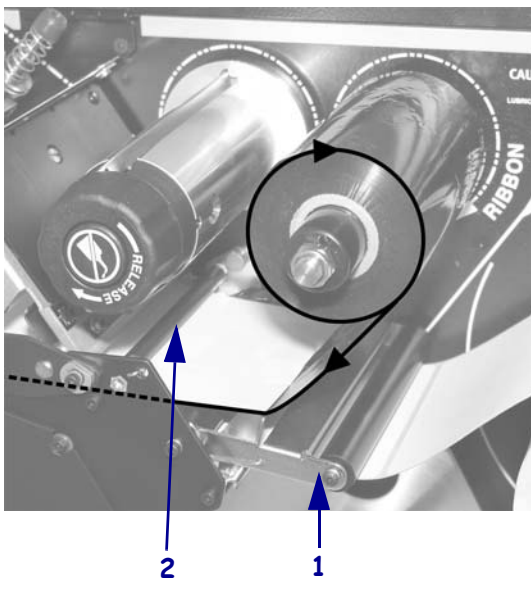
If...	Then...
No	<p>Thread the ribbon over the media dancer assembly (1) and under the ribbon guide roller (2).</p>  <p>The photograph shows a close-up of the printer's internal mechanism. A ribbon is being threaded over a roller labeled '1' (the media dancer assembly) and under another roller labeled '2' (the ribbon guide roller). A circular arrow indicates the rotation of roller 1. The word 'RIBBON' is visible on the right side of the image, and 'RELEASE' is on a button to the left.</p>

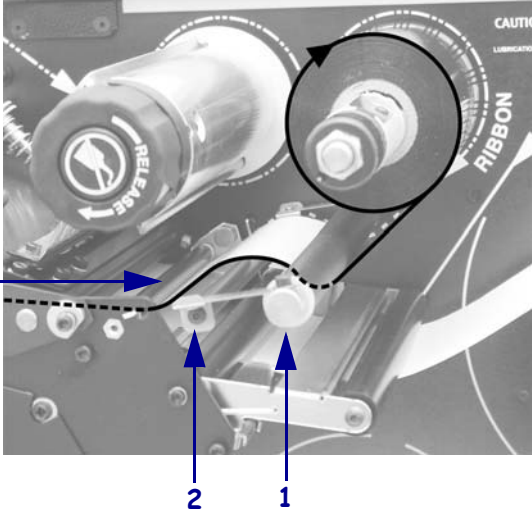
If...	Then...
Yes	<p>a. Thread the ribbon through the ribbon dancer. The ribbon must go under the upper roller (1) and then over the lower roller (2).</p> <p>b. Thread the ribbon under the ribbon guide roller (3).</p> 

8. Push the ribbon leader forward until it passes under the printhead assembly (1), over the snap plate (2), and then over the platen roller (3).

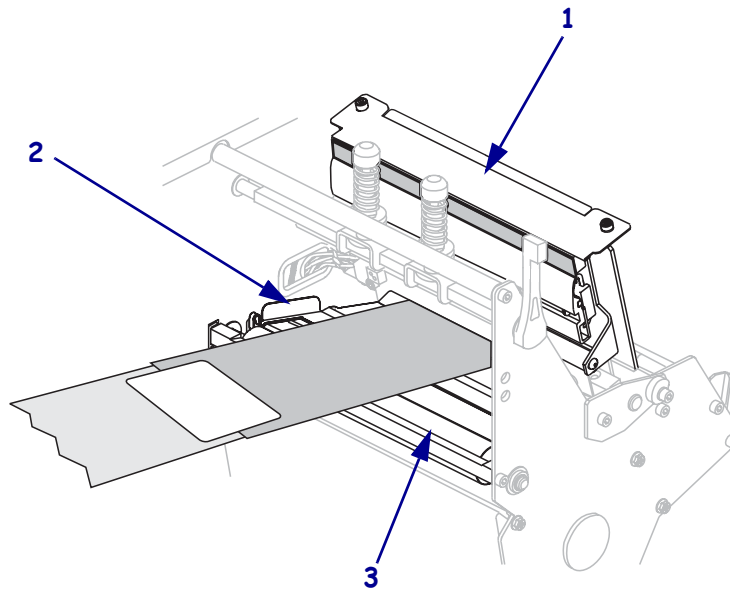

9. Bring the ribbon leader over the upper ribbon roller (1) and then toward the ribbon take-up spindle (2).

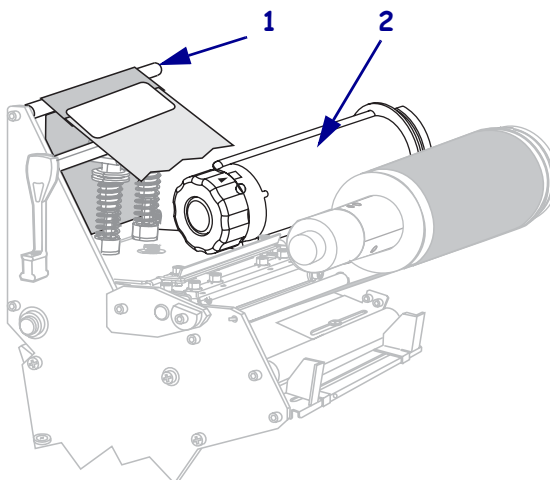

10. Wind the ribbon leader and attached ribbon counterclockwise around the ribbon take-up spindle.

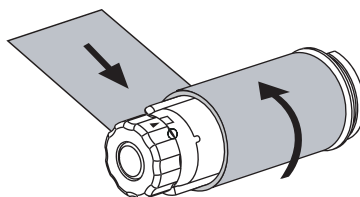

11. Rotate the spindle counterclockwise several turns to wind the ribbon and remove any slack.

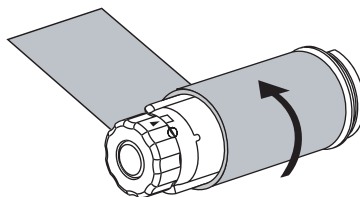

12. Push down the printhead assembly (1), and then rotate the printhead-open lever (2) clockwise until it locks into place.

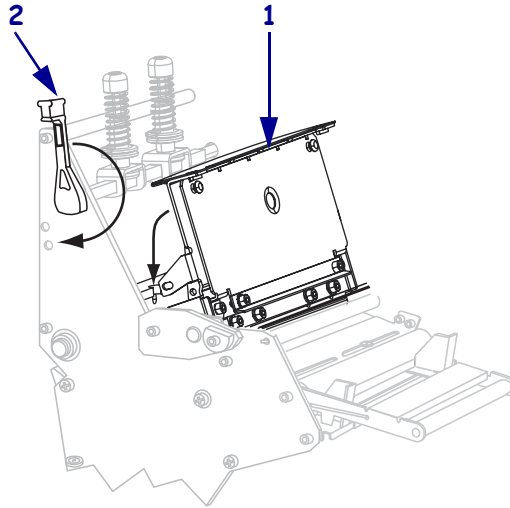

Remove Used Ribbon

Remove used ribbon from the ribbon take-up spindle each time you change the roll of ribbon.

To remove used ribbon, complete these steps:

1. Has the ribbon run out?

If the ribbon...	Then
Ran out	Continue with the next step.
Did not run out	Cut or break the ribbon before the ribbon take-up spindle.

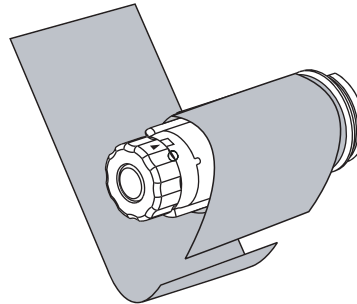

2. While holding the ribbon take-up spindle, turn the ribbon release knob clockwise until it stops.

The ribbon release bars pivot down, easing the spindle's grip on the used ribbon.

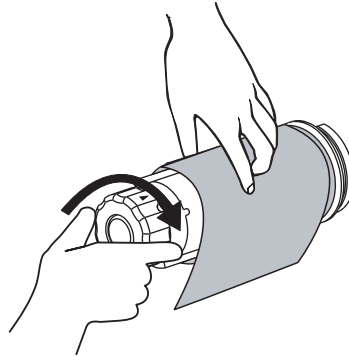

3. Slide the used ribbon off of the ribbon take-up spindle and discard.

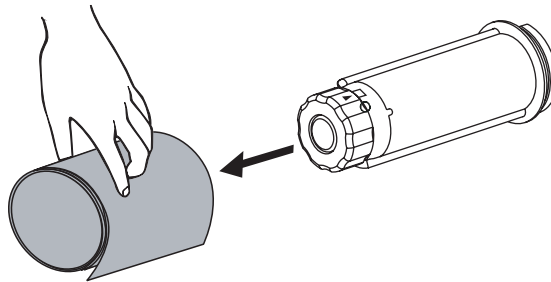

Calibrate the Printer

Calibrate the printer when it is first put into service. Calibration allows the printer to establish the proper settings for the specific media and ribbon used in your application. You may calibrate the printer at other times as needed. [Table 7](#) shows the different methods for calibration.

Table 7 • Types of Calibration

Type of Calibration	Description	When/How It Occurs
Auto-calibration	The printer automatically sets the value it detects for the spaces between labels.	Occurs at the following times: <ul style="list-style-type: none"> • When the printer is first turned on if CALIBRATION is selected for MEDIA POWER UP (see Select Media Power-Up Option on page 81). • When the printer feeds media after the printhead is closed if CALIBRATION is selected for HEAD CLOSE (see Select Head Close Option on page 82). • As part of both the sensor profile and media and ribbon sensor calibration procedures.
Long (Standard) Calibration	The printer does the following: <ul style="list-style-type: none"> • feeds media and ribbon • sets the values it detects for media length, media type (continuous or non-continuous), and print mode (thermal transfer or direct thermal) • updates the sensor values 	To perform a long calibration, do one of the following: <ul style="list-style-type: none"> • Press PAUSE on the control panel to pause the printer, and then press CALIBRATE. • Select CALIBRATION for the MEDIA POWER UP or HEAD CLOSE parameter (see Select Media Power-Up Option on page 81 or Select Head Close Option on page 82).
Short Calibration	The printer calibrates using the current sensor values rather than detecting the spaces between labels and resetting the sensors. This calibration sequence uses fewer labels than the long calibration sequence, but it is less reliable because the values that are stored in the sensors could be incorrect.	Select SHORT CAL for the MEDIA POWER UP or HEAD CLOSE parameter (see Select Media Power-Up Option on page 81 or Select Head Close Option on page 82).

Table 7 • Types of Calibration (Continued)

Type of Calibration	Description	When/How It Occurs
Sensor Profile Calibration	The printer auto-calibrates and prints a media sensor profile.	Select the SENSOR PROFILE option on the control panel. See <i>Print Sensor Profile</i> on page 76 for instructions.
Media and Ribbon Sensor Sensitivity Calibration	One of the most common adjustments to printer settings. The printer resets the sensitivity of the sensors to detect correctly the media and ribbon that you are using. If you change the type of ribbon and/or media, you might need to reset the sensitivity of the media and ribbon sensors. When the sensors are at their new sensitivity, the printer performs an auto-calibration.	Select the MEDIA AND RIBBON CALIBRATE option on the control panel. See <i>Calibrate Media and Ribbon Sensor Sensitivity</i> on page 77 for instructions.

Adjust Media Sensors

The transmissive sensor consists of two sections: a light source (the lower media sensor) and a light sensor (the upper media sensor). The media passes between the two. The upper media sensor can be positioned along the inside half of the media (the side closest to the back of the printer) or the outside half of the media (the side farthest from the back of the printer).

Adjust these sensors only when the printer cannot detect the top of the label. The control panel LCD displays **ERROR CONDITION PAPER OUT**, even though there are labels loaded in the printer.

Upper Media Sensor—Inside Half of Media

To adjust the upper media sensor for the inside half of the media, complete these steps:

1. Remove the ribbon (if ribbon is used).
2. See [Figure 20](#). Locate the upper media sensor. The upper media sensor eye is directly below the adjustment screw head.

Figure 20 • Upper Media Sensor Location

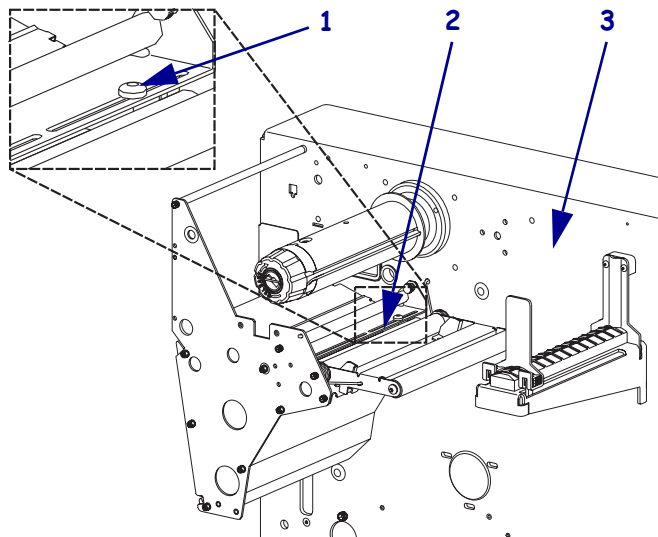

1	Upper media sensor adjustment screw
2	Upper media sensor
3	Printer back frame

3. Using a Phillips-head screwdriver, slightly loosen the upper media sensor adjustment screw.
4. Using the tip of the screwdriver, slide the upper sensor along the slot to the desired position (for non-continuous media with a notch or hole in the media, the sensor must be directly above the notch or hole).

5. Tighten the adjustment screw to secure the upper media sensor.

Upper Media Sensor—Outside Half of Media

To adjust the upper media sensor for the outside half of the media, complete these steps:

1. Remove the ribbon (if ribbon is used).
2. See [Figure 20](#). Locate the upper media sensor. The upper media sensor eye is directly below the adjustment screw head.
3. Using a Phillips-head screwdriver, remove the upper media sensor adjustment screw.
4. Lift the upper media sensor assembly from the slot, and move it and the wire cover to the outside slot. Carefully pull the wires through the cable tie. You may need to set aside the sensor wire cover if the adjustment is too far to the outside.
5. Replace and slightly tighten the adjustment screw.
6. Slide the upper media sensor along the slot to the desired position (for non-continuous media with a notch or hole in the media, the sensor must be directly above the notch or hole).
7. Tighten the adjustment screw.
8. Make sure that the wires are routed back into the groove of the media sensor bracket.

Lower Media Sensor

To adjust the lower media sensor, complete these steps:

1. Locate the lower media sensor assembly under the rear roller (Figure 21). The sensor is a spring clip holding a circuit board.

Figure 21 • Lower Media Sensor Location

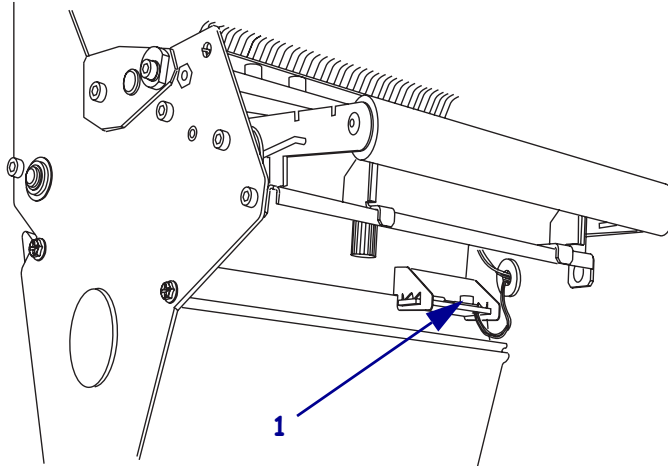

1	Lower media sensor
---	--------------------

2. Slide the lower sensor until it is under the upper media sensor. Gently pull wires out as needed (wires should have a little slack).

Adjust Printhead Pressure and Toggle Position

Print quality depends on the labels and ribbon used as well as the toggle pressure and position. Make sure that your labels and ribbon are acceptable for your application. If they are, check the toggle position and then the printhead pressure.

Toggle Position Adjustment

You may need to adjust the toggles if printing is too light on one side or if thick labels are used. If the toggle pressure is too light or uneven, the labels and ribbon may slip.

To position the toggles, complete these steps:

1. Loosen the locking nuts (1) at the top of the toggle assemblies.

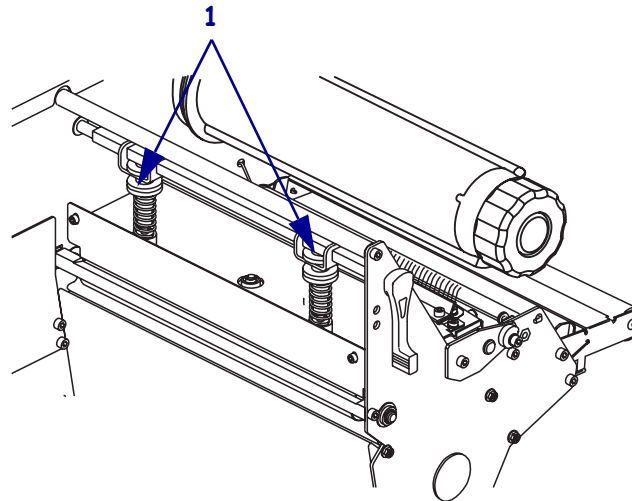

2. Slide the toggles until they provide even pressure on the media. For extremely narrow media, position one toggle over the center of the labels, and decrease the pressure on the unused toggle.
3. Tighten the locking nuts.

Printhead Pressure Adjustment

If positioning the toggles properly does not solve a print quality problem, try adjusting the printhead pressure. Maximize printhead life by using the lowest pressure that produces the desired print quality.



Caution • Observe proper electrostatic safety precautions when handling any static-sensitive components such as circuit boards and printheads.

To adjust printhead pressure, complete these steps:

1. Print some labels at 2.4 in. (61 mm) per second by running the *PAUSE Self Test* on page 153.
2. While printing labels, use the control panel controls to lower the darkness setting until the labels are printing gray instead of black.
3. Loosen the upper knurled nuts on the toggle assemblies (1).

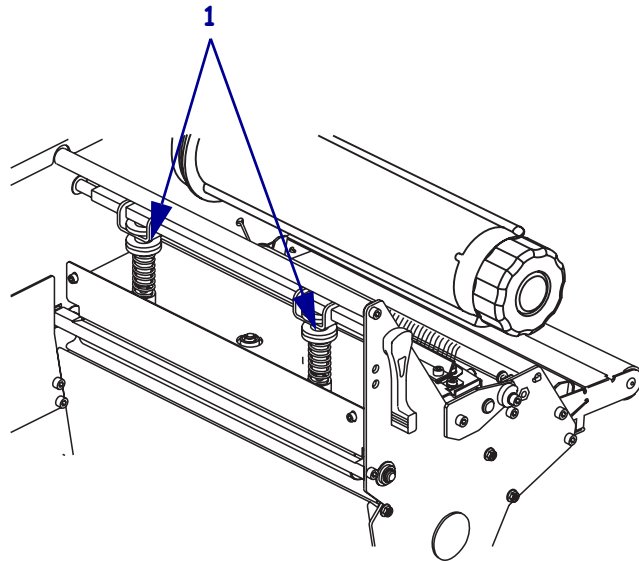

4. Some media types require higher pressure to print well. For these media types, increase or decrease pressure using the lower knurled nuts (**1**) until the left and right edges of the printed area are equally dark.

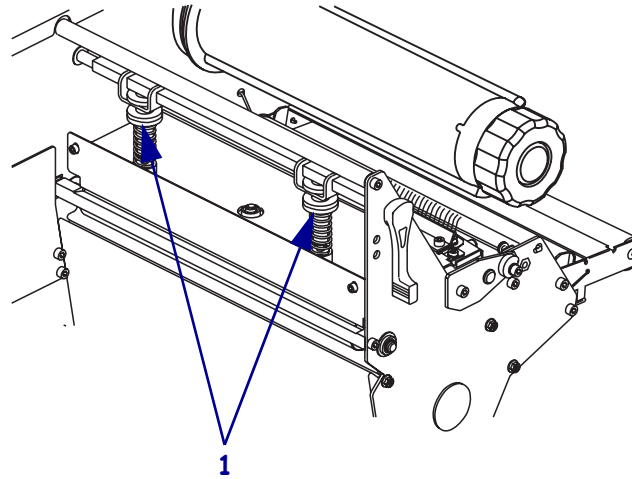

5. Increase the darkness level using the control panel controls until the printing is clear.
6. Tighten the upper knurled nuts.



Notes • _____

Configuration

This section describes the control panel parameters that are used to configure the printer for operation.

Contents

Setup Mode	58
Enter Setup Mode	58
Exit Setup Mode	59
Change Password-Protected Parameters	60
Default Password Value	60
Disable the Password Protection Feature	60
Print a Configuration Label	61
Print a Network Configuration Label	62
Control Panel Parameters	63
How to View or Modify Parameters	63
Additional Parameters	63
Standard Printer Parameters	63

Setup Mode

After you have installed the media and ribbon and the Power-On Self Test (POST) is complete, the control panel displays **PRINTER READY**. You may now set printer parameters for your application using the control panel display and the buttons directly below it. If it becomes necessary to restore the initial printer defaults, see [FEED and PAUSE Self Test on page 158](#).



Important • Certain printing conditions may require that you adjust printing parameters, such as print speed, darkness, or print mode. These conditions include (but are not limited to):

- printing at high speeds
- peeling the media
- the use of extremely thin, small, synthetic, or coated labels

Because these and other factors affect print quality, run tests to determine the best combination of printer settings and media for your application. A poor match may limit print quality or print rate, or the printer may not function properly in the desired print mode.

Enter Setup Mode

To enter Setup Mode, complete these steps:

1. Press SETUP/EXIT.
2. Press NEXT/SAVE or PREVIOUS to scroll through the parameters.

Exit Setup Mode

To leave Setup mode, complete these steps:

1. Press SETUP/EXIT.
The LCD displays **SAVE CHANGES**.
2. Press the left or right oval to display the save options (Table 8).

Table 8 • Save Options When Leaving Setup Mode

LCD	Description
PERMANENT	Stores values in the printer even when power is turned off.
TEMPORARY	Saves the changes until power is turned off.
CANCEL	Cancels all changes made since you entered Setup mode, except for changes made to the darkness and tear-off settings, which go into effect as soon as they are made.
LOAD DEFAULTS	Restores all parameters other than the network settings back to the factory defaults. Use care when loading defaults because you will need to reload all settings that you changed manually.  Note • Loading factory defaults causes the printer to auto-calibrate.
LOAD LAST SAVE	Loads values from the last permanent save.
DEFAULT NET	Restores the wired and wireless network settings back to factory defaults.

3. Press NEXT/SAVE to select the displayed choice.
When the configuration and calibration sequence is done, **PRINTER READY** displays.

Change Password-Protected Parameters

Certain parameters, including the communication parameters, are password-protected by factory default.

Caution • Do not change password-protected parameters unless you have a complete understanding of the parameters' functions. If the parameters are set incorrectly, the printer may function unpredictably.

The first time that you attempt to change a password-protected parameter, the printer displays **ENTER PASSWORD**. Before you can change the parameter, you must enter the four-digit numeric password. After you have entered the password correctly, you do not have to enter it again unless you leave Setup mode by pressing **SETUP/EXIT** or by turning off (O) the printer.

To enter a password for a password-protected parameter, complete these steps:

1. At the password prompt, use the left oval to change the selected digit position.
2. When you have selected the digit that you wish to change, use the right oval to increase the selected digit value. Repeat these two steps for each digit of the password.
3. After entering the password, press **NEXT/SAVE**.

The parameter you selected to change is displayed. If the password was entered correctly, you can change the value.

Default Password Value

The default password value is **1234**. The password can be changed using the Zebra Programming Language (ZPL) command **^KP** (Define Password).

Disable the Password Protection Feature

You can disable the password protection feature so that it no longer prompts you for a password by setting the password to **0000** via the **^KP** ZPL command. To re-enable the password-protection feature, send the ZPL command **^KPx**, where **x** can be any number from 1 to 9999.

Print a Configuration Label

A configuration label lists the printer settings that are stored in configuration memory. After you load the media and ribbon (if necessary), print a configuration label as a record of your printer's current settings. Keep the label to use when troubleshooting printing problems.

To print a configuration label, complete these steps:

1. On the control panel, press SETUP/EXIT.
2. Press NEXT/SAVE or PREVIOUS to scroll through the parameters until you reach **LIST SETUP**.
3. Press the right oval to confirm printing.
A configuration label prints (Figure 22).

Figure 22 • Configuration Label

PRINTER CONFIGURATION	
Brady Corporation	
Bradyprinter X-PLUS II Series	
+11.....	DARKNESS
+000.....	TEAR OFF
TEAR OFF.....	PRINT MODE
CONTINUOUS.....	MEDIA TYPE
WEB.....	SENSOR TYPE
AUTO SELECT.....	SENSOR SELECT
THERMAL-TRANS.....	PRINT METHOD
168 00/12 MM.....	PRINT WIDTH
1219.....	LABEL LENGTH
RS232.....	SERIAL COMM.
38400.....	BAUD
8 BITS.....	DATA BITS
NONE.....	PARITY
XON/XOFF.....	HOST HANDSHAKE
NONE.....	PROTOCOL
000.....	NETWORK ID
NORMAL MODE.....	COMMUNICATIONS
<~> 7EH.....	CONTROL PREFIX
<^> 5EH.....	FORMAT PREFIX
<,> 2CH.....	DELIMITER CHAR
ZPL II.....	ZPL MODE
CALIBRATION.....	MEDIA POWER UP
CALIBRATION.....	HEAD CLOSE
DEFAULT.....	BACKFEED
+000.....	LABEL TOP
+0000.....	LEFT POSITION
058.....	WEB S.
068.....	MEDIA S.
072.....	RIBBON S.
001.....	TAKE LABEL
213.....	MEDIA LED
111.....	RIBBON LED
+10.....	LCD ADJUST
DPSWFXM.....	MODES ENABLED
.....	MODES DISABLED
1984 12/MM FULL.....	RESOLUTION
V39.10.5P02 <-.....	FIRMWARE
V1.9.0.0.....	HARDWARE ID
CUSTOMIZED.....	CONFIGURATION
3072.....R:	RAM
NONE.....B:	MEMORY CARD
2048.....E:	ONBOARD FLASH
NONE.....	FORMAT CONVERT
NONE.....	OPTION
PERMANENT.....	IP RESOLUTION
ALL.....	IP PROTOCOL
010.003.004.150.....	IP ADDRESS
255.000.000.000.....	SUBNET MASK
000.000.000.000.....	DEFAULT GATEWAY
2000-12-18 12:18:18	TIME STAMP

FIRMWARE IN THIS PRINTER IS COPYRIGHTED

Print a Network Configuration Label

If you are using a print server, you can print a network configuration label after the printer is connected to the network.

To print a network configuration label, complete these steps:

1. On the control panel, press SETUP/EXIT.
2. Press NEXT/SAVE or PREVIOUS to scroll through the parameters until you reach **LIST NETWORK**.
3. Press the right oval to confirm printing.

A network configuration label prints (Figure 23). An asterisk designates whether the wired or wireless print server is active. If no wireless print server is installed, the wireless portion of the label does not print.

Figure 23 • Network Configuration Label (With a Wireless Print Server Installed)

Network Configuration	
Zebra Technologies PRINTER MODEL XXXdpi USER-DEFINED TEXT	
NO.....	WIRED PS CHECK?
Printer.....	LOAD LAN FROM?
Wired	
ALL.....	IP PROTOCOL
000.000.000.000.....	IP ADDRESS
000.000.000.000.....	SUBNET MASK
000.000.000.000.....	DEFAULT GATEWAY
000.000.000.000.....	WINS SERVER IP
YES.....	TIMEOUT CHECKING
0300.....	TIMEOUT VALUE
0000.....	ARP INTERVAL
9100.....	BASE RAW PORT
Wireless*	
ALL.....	IP PROTOCOL
010.003.015.089.....	IP ADDRESS
255.255.255.000.....	SUBNET MASK
010.003.015.001.....	DEFAULT GATEWAY
010.003.001.015.....	WINS SERVER IP
YES.....	TIMEOUT CHECKING
0300.....	TIMEOUT VALUE
0000.....	ARP INTERVAL
9100.....	BASE RAW PORT
YES.....	CARD INSERTED
015FH.....	CARD MFG ID
000AH.....	CARD PRODUCT ID
000e83df3bc?.....	MAC ADDRESS
YES.....	DRIVER INSTALLED
INFRASTRUCTURE.....	OPERATING MODE
vh-CTC-PRD.....	ESSID
100.....	TX POWER
0N.....	1 Mb/s
0N.....	2 Mb/s
0N.....	5.5 Mb/s
0N.....	11 Mb/s
11 Mb/s.....	CURRENT TX RATE
DIVERSITY.....	RECEIVE ANTENNA
DIVERSITY.....	XMIT ANTENNA
OPEN.....	AUTH. TYPE
OFF.....	LEAP MODE
128-bit.....	ENCRYPTION MODE
1.....	ENCRYPT. INDEX
020.....	POOR SIGNAL
LONG.....	PREAMBLE
YES.....	ASSOCIATED

FIRMWARE IN THIS PRINTER IS COPYRIGHTED

Control Panel Parameters

Use the LCD on the control panel to view and adjust printer settings.

How to View or Modify Parameters

While viewing parameters, press NEXT/SAVE to continue to the next parameter, or press PREVIOUS to return to the previous parameter in the cycle. When a parameter is changed, an asterisk (*) appears in the upper left corner of the display to indicate that the value is different from the one currently active in the printer.



Note • Your label preparation software or the printer driver may override adjustments made through the control panel. Refer to the software or driver documentation for more information.

Additional Parameters

Additional parameters appear if a BradyConnect PrintServer II (PSII) is installed.

Standard Printer Parameters

[Table 9](#) shows parameters in the order in which they are displayed when you press NEXT/SAVE after entering Setup mode.

Table 9 • Printer Parameters (Sheet 1 of 26)



Parameter	Action/Explanation
	<p>Adjust Print Darkness</p> <p>Darkness (burn duration) settings depend on a variety of factors, including ribbon type, media type, and the condition of the printhead. You may adjust the darkness for consistent high-quality printing.</p> <p> Important • Set the darkness to the lowest setting that provides good print quality. If the darkness is set too high, the ink may smear, the ribbon may burn through, or the printhead may wear prematurely.</p> <p>If printing is too light or if there are voids in printed areas, increase the darkness. If printing is too dark or if there is spreading or bleeding of printed areas, decrease the darkness.</p> <p>The FEED Self Test on page 154 can be used to determine the best darkness setting. You may want to adjust darkness while performing the PAUSE Self Test on page 153. Because the darkness setting takes effect immediately, you can see the results on labels that are currently printing. Darkness settings also may be changed by the driver or software settings.</p> <p>Default: +04.0 Range: 00.0 to +30.0</p> <p>To change the value shown:</p> <ol style="list-style-type: none"> 1. Press the right oval to increase darkness. 2. Press the left oval to decrease darkness.
	<p>Adjust Print Speed</p> <p>Adjusts the speed for printing a label (given in inches per second). Slower print speeds typically yield better print quality. Print speed changes take effect upon exiting Setup mode.</p> <p>Default: 2 IPS Range: 2 to 12 IPS (depends on specific printer)</p> <p>To change the value shown:</p> <ol style="list-style-type: none"> 1. Press the right oval to increase the value. 2. Press the left oval to decrease the value.

Table 9 • Printer Parameters (Sheet 2 of 26)

Parameter	Action/Explanation				
<div style="border: 1px solid black; padding: 5px; display: flex; justify-content: space-between;"> TEAR OFF +000 </div> <div style="border: 1px solid black; padding: 5px; display: flex; justify-content: space-between;"> - ■■■■■■ + </div>	<p>Adjust the Tear-Off Position</p> <p>This parameter establishes the position of the media over the tear-off/peel-off bar after printing.</p> <p>See Figure 24. Higher numbers move the media out (the tear line moves closer to the leading edge of the next label), and lower numbers move the media in (the tear line moves closer to the edge of the label just printed).</p> <div style="text-align: center;"> <p>Figure 24 • Tear-Off Position Adjustment</p>  <table border="1" style="margin: 10px auto;"> <tr> <td style="text-align: center;">1</td> <td>Media direction</td> </tr> <tr> <td style="text-align: center;">2</td> <td>Factory-set tear line location at position 00</td> </tr> </table> </div> <p>Default: +0 Range: -120 to +120</p> <p>To change the value shown:</p> <ol style="list-style-type: none"> Press the right oval to increase the value. Each press adjusts the tear-off position by four dot rows. Press the left oval to decrease the value. Each press adjusts the tear-off position by four dot rows. 	1	Media direction	2	Factory-set tear line location at position 00
1	Media direction				
2	Factory-set tear line location at position 00				
<div style="border: 1px solid black; padding: 5px; display: flex; justify-content: space-between;"> PRINT MODE </div> <div style="border: 1px solid black; padding: 5px; display: flex; justify-content: space-between;"> -TEAR-OFF + </div>	<p>Select Print Mode</p> <p>Print mode settings tell the printer the method of media delivery that you wish to use. Make sure that your printer can support the selected option.</p> <p>Default: TEAR-OFF</p> <p>Selections: TEAR-OFF, PEEL-OFF, CUTTER, DELAYED CUT, APPLICATOR, REWIND</p> <p>To change the value shown:</p> <ol style="list-style-type: none"> Press the left or right oval to scroll through the options. 				

Table 9 • Printer Parameters (Sheet 3 of 26)

Parameter	Action/Explanation
<div style="border: 1px solid black; padding: 5px;"> MEDIA TYPE -NON-CONTINUOUS + </div>	<p>Set Media Type</p> <p>This parameter tells the printer the type of media that you are using (see <i>Types of Media</i> on page 26 for more information). Selecting continuous media requires that you include a label length instruction in your label format (^Lxxxxx if you are using ZPL or ZPL II).</p> <p>When non-continuous media is selected, the printer feeds media to calculate label length (the distance between two recognized registration points of the inter-label gap, webbing, or alignment notch or hole).</p> <p>Default: NON-CONTINUOUS</p> <p>Selections: CONTINUOUS, NON-CONTINUOUS</p> <p>To change the value shown:</p> <ol style="list-style-type: none"> 1. Press the left or right oval to toggle between the options.
<div style="border: 1px solid black; padding: 5px;"> SENSOR TYPE -WEB + </div>	<p>Set the Sensor Type</p> <p>This parameter tells the printer whether you are using media with a web (gap/space between labels, notch, or hole) to indicate the separations between labels or if you are using media with a black mark printed on the back. If your media does not have black marks for registration on the back, leave your printer at the default (WEB).</p> <p>Default: WEB</p> <p>Selections: WEB, MARK</p> <p>To change the value shown:</p> <ol style="list-style-type: none"> 1. Press the left or right oval to toggle between the options.
<div style="border: 1px solid black; padding: 5px;"> PRINT METHOD -THERMAL-TRANS. + </div>	<p>Select Print Method</p> <p>The print method parameter tells the printer the method of printing that you wish to use: direct thermal (no ribbon) or thermal transfer (using thermal transfer media and ribbon).</p> <p>Default: THERMAL TRANSFER</p> <p>Selections: THERMAL TRANSFER, DIRECT THERMAL</p> <p> Note • Selecting direct thermal when using thermal transfer media and ribbon creates an error condition, but printing continues.</p> <p>To change the value shown:</p> <ol style="list-style-type: none"> 1. Press the left or right oval to toggle between the options.

Table 9 • Printer Parameters (Sheet 4 of 26)

Parameter	Action/Explanation
<div style="border: 1px solid black; padding: 5px; width: fit-content;"> PRINT WIDTH - MM + </div>	<p>Set Print Width</p> <p>Determines the printable area across the width of the label given the resolution of the printer.</p> <p> Note • Setting the width too narrow can result in portions of the label not being printed on the media. Setting the width too wide wastes formatting memory and can cause printing off the label and on the platen roller. This setting can affect the horizontal position of the label format if the image was inverted using the ^POI ZPL II command.</p> <p>To change the value shown:</p> <ol style="list-style-type: none"> 1. Press the left oval to move the cursor. 2. Press the right oval to increase the value of the digit. <p>To change the unit of measurement:</p> <ol style="list-style-type: none"> 1. Press the left oval until the unit of measurement is active. 2. Press the right oval to toggle to a different unit of measure (mm, inches, or dots).

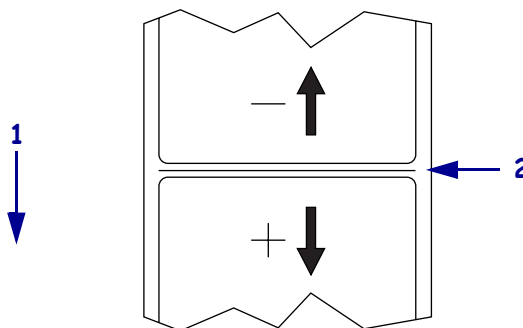
Table 9 • Printer Parameters (Sheet 5 of 26)

Parameter	Action/Explanation						
<table border="1"> <tr> <td>MAXIMUM LENGTH</td> <td></td> </tr> <tr> <td>39.0IN</td> <td>988MM</td> </tr> </table>	MAXIMUM LENGTH		39.0IN	988MM	<p>Set Maximum Label Length</p> <p>This parameter is used during the media portion of the calibration process. Always set maximum label length to a value that is at least 1.0 in. (25.4 mm) greater than the actual label length (Figure 25). If the value is set to a smaller value than the label length, the printer assumes that continuous media is loaded, and the printer cannot calibrate.</p> <p>For example, if the label length is 5.0 inches (126 mm) including the interlabel gap, set the parameter for 6.0 inches (152 mm). If the label length is 7.5 inches (190 mm), set the parameter for 9.0 inches (229 mm).</p>		
MAXIMUM LENGTH							
39.0IN	988MM						
<p style="text-align: center;">Figure 25 • Label Length</p>  <table border="1" data-bbox="654 1392 1344 1539"> <tr> <td>1</td> <td>Label length (including interlabel gap)</td> </tr> <tr> <td>2</td> <td>Interlabel gap</td> </tr> <tr> <td>3</td> <td>Set maximum label length to approximately this value</td> </tr> </table>		1	Label length (including interlabel gap)	2	Interlabel gap	3	Set maximum label length to approximately this value
1	Label length (including interlabel gap)						
2	Interlabel gap						
3	Set maximum label length to approximately this value						
<p>Default: 39.0 inches (988 mm).</p> <p>Range: Values are adjustable in one-inch (25.4 mm) increments.</p> <p>To change the value shown:</p> <ol style="list-style-type: none"> Press the right oval to increase the value. Press the left oval to decrease the value. 							

Table 9 • Printer Parameters (Sheet 6 of 26)

Parameter	Action/Explanation
<div style="border: 1px solid black; padding: 2px; text-align: center;"> EARLY WARNING MEDIA DISABLED </div>	<p>Set Early Warning for Media When this parameter is enabled, the printer provides warnings when labels are running low.</p> <p> Note • Update the number of labels per roll when beginning use of the Early Warning System. The printer does not make any adjustments when power is turned off and on.</p> <p>Default: MEDIA DISABLED Selections: MEDIA DISABLED, MEDIA ENABLED</p> <p>To change the Early Warning settings:</p> <ol style="list-style-type: none"> 1. When the LCD displays EARLY WARNING MEDIA, press the left or right oval to toggle between ENABLED and DISABLED. (If you are prompted for a password, enter your password using the instructions in Change Password-Protected Parameters on page 60.) 2. If you enable the Early Warning System, do the following: <ol style="list-style-type: none"> a. Exit Setup mode and save changes to enable additional parameters. b. Enter Setup mode again. The media and ribbon parameters (LABELS PER ROLL, MEDIA REPLACED, RIBBON LENGTH, and RIBBON REPLACED) appear. c. Adjust the settings as necessary (descriptions of each of these parameters follows).
<div style="border: 1px solid black; padding: 2px; text-align: center;"> LABELS PER ROLL - 0900 + </div>	<p>Set Number of Labels Per Roll for Early Warning This parameter appears only when Early Warning for Media is enabled. This value should correspond to the number of labels per roll of the media that you are using.</p> <p>Default: 0900 Range: 100 to 9999</p> <p>To change the value shown:</p> <ol style="list-style-type: none"> 1. Press the left oval to move the cursor. 2. Press the right oval to increase the value of the digit. Based on the number entered, when the printer detects that less than 15% of the labels remain, WARNING MEDIA LOW appears on the LCD. If the alert function is enabled, the printer generates an alert. When the printhead is opened and then closed after a media warning is received, the LCD prompts with MEDIA REPLACED? 3. If you replaced the media, press the right oval to select YES to clear the warning and reset the label counter. If you did not replace the media, press the left oval to select NO.

Table 9 • Printer Parameters (Sheet 7 of 26)

Parameter	Action/Explanation
<div style="border: 1px solid black; padding: 5px;"> <p>MEDIA REPLACED? NO YES</p> </div>	<p>Reset Media Counter for Early Warning This parameter appears only when Early Warning for Media is enabled.</p> <p>To reset the media counter:</p> <ol style="list-style-type: none"> 1. Did you replace the media? <ol style="list-style-type: none"> a. If you replaced the media, press the right oval to select YES. b. If you did not replace the media, press the left oval to select NO.
<div style="border: 1px solid black; padding: 5px;"> <p>RIBBON LENGTH - 450M 1476 FT +</p> </div>	<p>Set Ribbon Length for Early Warning This parameter appears only when Early Warning for Media is enabled and the printer is set for Thermal Transfer operation.</p> <p>Default: 450 M/1476 FT Range: 100 M/328 FT to 450 M/1476 FT in 50 M increments</p> <p>To change the value shown:</p> <ol style="list-style-type: none"> 1. Press the left or right oval to set the value to match the length of the ribbon that you are using. Based on the number entered, when the printer detects that less than 15% of the ribbon remains, WARNING RIBBON LOW appears on the LCD. If the alert function is enabled, the printer generates an alert. When the printhead is opened and then closed after a ribbon warning is received, the LCD prompts with RIBBON REPLACED?.
<div style="border: 1px solid black; padding: 5px;"> <p>RIBBON REPLACED? NO YES</p> </div>	<p>Reset Ribbon Counter for Early Warning This parameter appears only when Early Warning for Media is enabled and the printer is set for Thermal Transfer operation.</p> <p>To reset the ribbon counter:</p> <ol style="list-style-type: none"> 1. Did you replace the ribbon? <ol style="list-style-type: none"> a. If you replaced the ribbon, press the right oval to select YES. b. If you did not replace the ribbon, press the left oval to select NO.

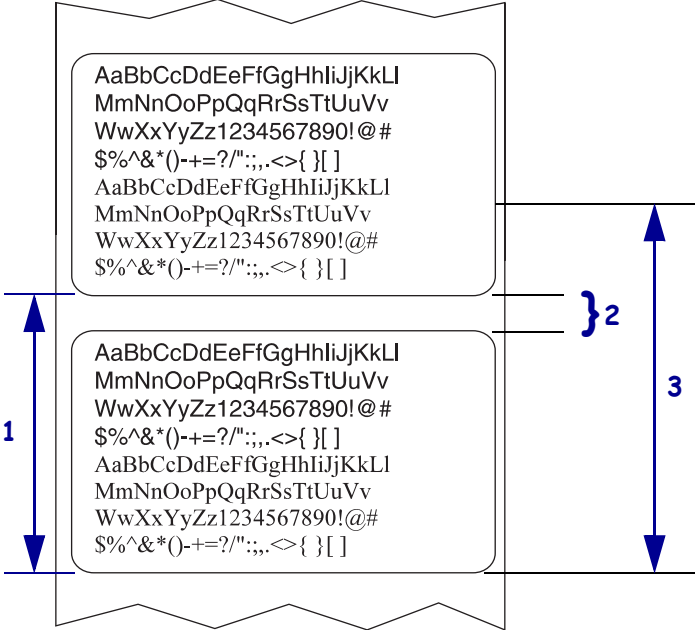
Table 9 • Printer Parameters (Sheet 8 of 26)

Parameter	Action/Explanation
<div style="border: 1px solid black; padding: 5px;"> <p>EARLY WARNING MAINT. OFF</p> </div>	<p>Set Early Warning for Maintenance When this parameter is enabled, the printer provides warnings when the printhead needs to be cleaned.</p> <p> Note • If necessary, update the number of labels per roll when beginning use of the Early Warning System for Maintenance. The printer does not make any adjustments when power is turned off and on.</p> <p>Default: MAINT. OFF Selections: MAINT. OFF, MAINTENANCE ON</p> <p>To change the Early Warning settings:</p> <ol style="list-style-type: none"> When the LCD displays EARLY WARNING MAINTENANCE, press the left or right oval to toggle between OFF and ON. (If you are prompted for a password, enter your password using the instructions in Change Password-Protected Parameters on page 60.) Exit Setup mode and save changes to enable additional parameters related to the early warning system. Enter Setup mode again and go to the following parameters to enter the printhead cleaning interval and the printhead life.
<div style="border: 1px solid black; padding: 5px;"> <p>HEAD CLEANING - 450M 1476 FT +</p> </div>	<p>Set Printhead Cleaning Interval for Early Warning This parameter appears only when Early Warning for Maintenance is enabled. This value should correspond to the length of the media or ribbon roll that you are using.</p> <p>Default: 450 M/1476 FT Range: 100 M/328 FT to 450 M/1476 FT in 50 M increments</p> <p>To change the value shown:</p> <ol style="list-style-type: none"> Press the left or right oval to set the printhead cleaning interval to the desired number of inches of media or ribbon. When the printhead reaches the set length, WARNING CLEAN PRINTHEAD appears on the LCD. If the alert function is enabled, the printer generates an alert. When the printhead is opened and then closed after a printhead cleaning warning is received, the LCD prompts with HEAD CLEANED?.
<div style="border: 1px solid black; padding: 5px;"> <p>HEAD CLEANED? NO YES</p> </div>	<p>Reset Printhead Cleaning Counter for Early Warning This parameter appears only when Early Warning for Maintenance is enabled.</p> <p>To reset the printhead cleaning counter:</p> <ol style="list-style-type: none"> Did you clean the printhead? <ol style="list-style-type: none"> If you cleaned the printhead, press the right oval to select YES. If you did not clean the printhead, press the left oval to select NO.

Table 9 • Printer Parameters (Sheet 9 of 26)

Parameter	Action/Explanation
<div style="border: 1px solid black; padding: 5px;"> HEAD LIFE - 1000000 IN + </div>	<p>Set Printhead Life for Early Warning</p> <p>This parameter appears only when Early Warning for Maintenance is enabled. Set this value to the number of inches of media that the printhead is expected to print.</p> <p>Default: 1,000,000 inches Range: 100 to 1,000,000 inches</p> <p>To change the value shown:</p> <ol style="list-style-type: none"> 1. Press the left oval to move the cursor. 2. Press the right oval to increase the value of the digit. When the printhead reaches the set length, WARNING REPLACE HEAD appears on the LCD. If the alert function is enabled, the printer generates an alert. When the printhead is opened and then closed after a printhead life warning is received, the LCD prompts with NEW PRINTHEAD?. 3. If you replaced the printhead, press the right oval to select YES to clear the warning and reset the printhead life counter. If you did not replace the printhead, press the left oval to select NO.
<div style="border: 1px solid black; padding: 5px;"> NEW PRINTHEAD? NO YES </div>	<p>Reset Printhead Life Counter for Early Warning</p> <p>This parameter appears only when Early Warning for Maintenance is enabled.</p> <p>To reset the printhead life counter:</p> <ol style="list-style-type: none"> 1. Did you replace the printhead? <ol style="list-style-type: none"> a. If you replaced the printhead, press the right oval to select YES. b. If you did not replace the printhead, press the left oval to select NO.
<div style="border: 1px solid black; padding: 5px;"> LIST FONTS PRINT </div>	<p>List Fonts</p> <p>This option prints a label that lists the available fonts in the printer, including standard printer fonts plus any optional fonts. Fonts may be stored in RAM, Flash memory, optional PCMCIA font cards, or CompactFlash® cards.</p> <p>To print a list of the available fonts:</p> <ol style="list-style-type: none"> 1. Press the right oval to select PRINT.
<div style="border: 1px solid black; padding: 5px;"> LIST BAR CODES PRINT </div>	<p>List Bar Codes</p> <p>This option prints a label that lists the available bar codes in the printer. Bar codes may be stored in RAM, Flash memory, optional PCMCIA cards, or Compact Flash cards.</p> <p>To print a list of the available bar codes:</p> <ol style="list-style-type: none"> 1. Press the right oval to select PRINT.

Table 9 • Printer Parameters (Sheet 10 of 26)

Parameter	Action/Explanation
<div style="border: 1px solid black; padding: 5px; display: flex; justify-content: space-between;"> LIST IMAGES PRINT </div>	<p>List Images This option prints a label that lists the available images stored in the printer's RAM, Flash memory, optional memory card, PCMCIA cards, or Compact Flash cards.</p> <p>To print a list of the available images:</p> <ol style="list-style-type: none"> 1. Press the right oval to select PRINT.
<div style="border: 1px solid black; padding: 5px; display: flex; justify-content: space-between;"> LIST FORMATS PRINT </div>	<p>List Formats This option prints a label that lists the available formats stored in the printer's RAM, Flash memory, optional EPROM, or optional memory card.</p> <p>To print a list of the available formats:</p> <ol style="list-style-type: none"> 1. Press the right oval to select PRINT.
<div style="border: 1px solid black; padding: 5px; display: flex; justify-content: space-between;"> LIST SETUP PRINT </div>	<p>List Setup This option prints a configuration label (see Figure 22 on page 61), which lists the current printer configuration.</p> <p>To print a configuration label:</p> <ol style="list-style-type: none"> 1. Press the right oval to select PRINT.
<div style="border: 1px solid black; padding: 5px; display: flex; justify-content: space-between;"> LIST ALL PRINT </div>	<p>List All This option prints labels that list the available fonts, bar codes, images, formats, and the current printer and network configurations.</p> <p>To print labels for all settings:</p> <ol style="list-style-type: none"> 1. Press the right oval to select PRINT.

Table 9 • Printer Parameters (Sheet 12 of 26)

Parameter	Action/Explanation
<div style="border: 1px solid black; padding: 5px; text-align: center;"> INIT FLASH MEM. YES </div>	<p>Initialize Flash Memory This option erases all previously stored information from Flash memory. Caution • This option completely erases the Flash memory.</p> <p>To initialize Flash memory:</p> <ol style="list-style-type: none"> 1. Press the right oval to select YES. 2. Enter the password. For instructions, see <i>Change Password-Protected Parameters</i> on page 60. The display shows INITIALIZE FLASH? 3. Press the right oval to select YES. The display shows ARE YOU SURE? 4. Do you wish to continue? <ul style="list-style-type: none"> • Press the left oval to select NO to cancel the request and return to the INITIALIZE FLASH prompt. • Press the right oval to select YES and begin initialization. When initialization is complete, the printer automatically exits Setup mode, and the control panel displays PRINTER READY. If you exit Setup mode while initialization is still in process, the control panel display flashes between the phrases CHECKING E: MEMORY and PRINTER IDLE. <p> Note • Depending on the amount of free FLASH memory, initialization may take up to 1 minute to complete.</p>

Table 9 • Printer Parameters (Sheet 13 of 26)

Parameter	Action/Explanation
<p>SENSOR PROFILE PRINT</p>	<p>Print Sensor Profile</p> <p>A sensor profile shows sensor settings compared to actual sensor readings. This label (which will extend across several actual labels or tags) can be used to troubleshoot printing problems. To interpret the results of the sensor profile, see Sensor Profile on page 160.</p> <p style="text-align: center;">Figure 26 • Sensor Profile</p>  <p>To print a sensor profile:</p> <ol style="list-style-type: none"> 1. Press the right oval to start this standard calibration procedure and print a media sensor profile. 2. If the sensitivity of the sensors must be adjusted, perform Calibrate Media and Ribbon Sensor Sensitivity on page 77.

Table 9 • Printer Parameters (Sheet 14 of 26)

Parameter	Action/Explanation
MEDIA AND RIBBON CALIBRATE	<p>Calibrate Media and Ribbon Sensor Sensitivity Use this procedure to adjust sensitivity of media and ribbon sensors.</p> <p> Important • Follow this procedure exactly as presented. All of the steps must be performed even if only one of the sensors requires adjustment. You may press the left oval at any step in this procedure to cancel the process.</p> <p>To perform a media sensor calibration:</p> <ol style="list-style-type: none"> 1. Press the right oval to start the calibration procedure. The LOAD BACKING prompt displays. 2. Open the printhead. 3. Remove approximately 8 in. (203 mm) of labels from the backing, and pull the media into the printer so that only the backing is between the media sensors. 4. Leave the printhead open. 5. Press the right oval to continue. The REMOVE RIBBON prompt displays. 6. Remove the ribbon (if used). 7. Close the printhead. 8. Press the right oval to continue. The message CALIBRATING PLEASE WAIT displays. The printer adjusts the scale (gain) of the signals that it receives from the media and ribbon sensors based on the specific media and ribbon combination being used. On the sensor profile, this essentially corresponds to moving the peak of the graph up or down to optimize the readings for your application. When calibration is complete, RELOAD ALL displays. 9. Open the printhead and pull the media forward until a label is positioned under the media sensor. 10. Reload the ribbon (if used). 11. Close the printhead. 12. Press the right oval to continue. The printer performs an auto-calibration. During this process, the printer checks the readings for the media and ribbon based on the new scale established, determines the label length, and determines the print mode. To see the new readings on the new scale, print a sensor profile.

Table 9 • Printer Parameters (Sheet 15 of 26)

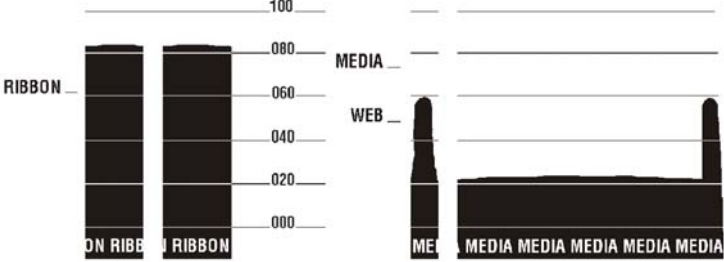

Parameter	Action/Explanation
<div style="border: 1px solid black; padding: 5px; display: inline-block;"> PARALLEL COMM. -BIDIRECTIONAL + </div>	<p>Set Parallel Communications</p> <p>Select the communications port that matches the one being used by the host computer.</p> <p>Default: BIDIRECTIONAL</p> <p>Selections: BIDIRECTIONAL, TWINAX/COAX, UNIDIRECTIONAL</p> <p>To change the value shown:</p> <ol style="list-style-type: none"> Press the left or right oval to scroll through the options.
<div style="border: 1px solid black; padding: 5px; display: inline-block;"> SERIAL COMM -RS232 + </div>	<p>Set Serial Communications</p> <p>Select the communications port that matches the one being used by the host computer. This setting applies only when the serial port is used.</p> <p> Important • Do not change this parameter from the default. The printer supports only RS-232. This parameter will be eliminated in a future version of the firmware.</p> <p>Default: RS232</p> <p>Selections: RS232, RS422/485, RS485 MULTIDROP</p> <p>To change the value shown:</p> <ol style="list-style-type: none"> Press the left or right oval to scroll through the options.
<div style="border: 1px solid black; padding: 5px; display: inline-block;"> BAUD -9600 + </div>	<p>Set Baud</p> <p>This setting applies only when the serial port is used. The baud setting of the printer must match the baud setting of the host computer for accurate communications to take place. Select the value that matches the one being used by the host computer.</p> <p>Default: 9600</p> <p>Selections: 110, 300, 600, 1200, 2400, 4800, 9600, 14400, 19200, 28800, 38400, 57600, 115200</p> <p>To change the value shown:</p> <ol style="list-style-type: none"> Press the left or right oval to scroll through the options.
<div style="border: 1px solid black; padding: 5px; display: inline-block;"> DATA BITS - 8 BITS </div>	<p>Set Data Bits</p> <p>This setting applies only when the serial port is used. The data bits of the printer must match the data bits of the host computer for accurate communications to take place. Set the data bits to match the setting being used by the host computer.</p> <p> Note • Code Page 850 requires the data bits to be set to 8 bits. See the <i>ZPL II Programming Guide</i> for more information.</p> <p>Default: 8 BITS</p> <p>Selections: 7 BITS, 8 BITS</p> <p>To change the value shown:</p> <ol style="list-style-type: none"> Press the left or right oval to toggle between the options.

Table 9 • Printer Parameters (Sheet 16 of 26)

Parameter	Action/Explanation
<div style="border: 1px solid black; padding: 5px;"> PARITY - NONE + </div>	<p>Set Parity</p> <p>This setting applies only when the serial port is used. The parity of the printer must match the parity of the host computer for accurate communications to take place. Select the parity that matches the one being used by the host computer.</p> <p>Default: NONE</p> <p>Selections: EVEN, ODD, NONE</p> <p>To change the value shown:</p> <ol style="list-style-type: none"> 1. Press the left or right oval to scroll through the options.
<div style="border: 1px solid black; padding: 5px;"> HOST HANDSHAKE - XON/XOFF + </div>	<p>Set Host Handshake</p> <p>This setting applies only when the serial port is used. The handshake protocol of the printer must match the handshake protocol of the host computer for communication to take place. Select the handshake protocol that matches the one being used by the host computer.</p> <p>Default: XON/XOFF</p> <p>Selections: XON/XOFF, DTR/DSR, RTS/CTS</p> <p>To change the value shown:</p> <ol style="list-style-type: none"> 1. Press the left or right oval to scroll through the options.
<div style="border: 1px solid black; padding: 5px;"> PROTOCOL - NONE + </div>	<p>Set Protocol</p> <p>Protocol is a type of error checking system. Depending on the selection, an indicator may be sent from the printer to the host computer signifying that data has been received. Select the protocol that is requested by the host computer. Further details on protocol can be found in the <i>ZPL II Programming Guide</i>.</p> <p>Default: NONE</p> <p>Selections: NONE, ZEBRA, ACK_NAK</p> <p> Note • ZEBRA is the same as ACK_NAK, except that ZEBRA response messages are sequenced. If ZEBRA is selected, the printer must use DTR/DSR for host handshake protocol.</p> <p>To change the value shown:</p> <ol style="list-style-type: none"> 1. Press the left or right oval to scroll through the options.
<div style="border: 1px solid black; padding: 5px;"> NETWORK ID - 000 + </div>	<p>Set Network ID</p> <p>Network ID is used to assign a unique number to a printer. This gives the host computer the means to address a specific printer. This does not affect TCP/IP or IPX networks.</p> <p>Default: 000</p> <p>Range: 000 to 999</p> <p>To change the value shown:</p> <ol style="list-style-type: none"> 1. Press the left oval to move to the next digit position. 2. Press the right oval to increase the value of the digit.

Table 9 • Printer Parameters (Sheet 17 of 26)



Parameter	Action/Explanation
<div style="border: 1px solid black; padding: 5px;"> COMMUNICATIONS - NORMAL MODE + </div>	<p>Set Communications Mode</p> <p>The communication diagnostics mode is a troubleshooting tool for checking the interconnection between the printer and the host computer. For more information, see <i>Communications Diagnostics Test</i> on page 159.</p> <p>Default: NORMAL MODE Selections: NORMAL MODE, DIAGNOSTICS</p> <p>To select communication diagnostics mode:</p> <ol style="list-style-type: none"> 1. Press the left or right oval to toggle between the options.
<div style="border: 1px solid black; padding: 5px;"> CONTROL PREFIX - < 7EH + </div>	<p>Set Control Prefix Character</p> <p>The printer looks for this two-digit hex character to indicate the start of a ZPL/ZPL II control instruction. The “H” that is displayed indicates Hexadecimal and is not part of the value.</p> <p> Note • Do not use the same hex value for the control, format, and delimiter character. The printer must see different characters to work properly.</p> <p>Default: 7E (tilde—displayed as a black square) Range: 00 to FF</p> <p>To change the value shown:</p> <ol style="list-style-type: none"> 1. Press the left oval to move to the next digit position. 2. Press the right oval to increase the value of the digit.
<div style="border: 1px solid black; padding: 5px;"> FORMAT PREFIX - < ^ > 5EH + </div>	<p>Set Format Prefix Character</p> <p>The format prefix is a two-digit hex value used as a parameter place marker in ZPL/ZPL II format instructions. The “H” that is displayed indicates Hexadecimal and is not part of the value. The printer looks for this hex character to indicate the start of a ZPL/ZPL II format instruction. See the <i>ZPL II Programming Guide Volume I</i> for more information.</p> <p> Note • Do not use the same hex value for the control, format, and delimiter character. The printer must see different characters to work properly.</p> <p>Default: 5E (caret) Range: 00 to FF</p> <p>To change the value shown:</p> <ol style="list-style-type: none"> 1. Press the left oval to move to the next digit position. 2. Press the right oval to increase the value of the digit.

Table 9 • Printer Parameters (Sheet 18 of 26)

Parameter	Action/Explanation
<div style="border: 1px solid black; padding: 5px;"> DELIMITER CHAR - <, >2CH + </div>	<p>Set Delimiter Character</p> <p>The delimiter character is a two-digit hex value used as a parameter place marker in ZPL/ZPL II format instructions. See the <i>ZPL II Programming Guide Volume I</i> for more information.</p> <p> Note • Do not use the same hex value for the control, format, and delimiter character. The printer must see different characters to work properly.</p> <p>Default: 2C (comma)</p> <p>Range: 00 to FF</p> <p>To change the value shown:</p> <ol style="list-style-type: none"> 1. Press the left oval to move to the next digit position. 2. Press the right oval to increase the value of the digit.
<div style="border: 1px solid black; padding: 5px;"> ZPL MODE - ZPL II + </div>	<p>Select ZPL Mode</p> <p>The printer remains in the selected mode until it is changed by this parameter or by using a ZPL/ZPL II command. The printer accepts label formats written in either ZPL or ZPL II, eliminating the need to rewrite any ZPL formats that already exist. See the <i>ZPL II Programming Guide</i> for more information on the differences between ZPL and ZPL II.</p> <p>Default: ZPL II</p> <p>Selections: ZPL II, ZPL</p> <p>To change the value shown:</p> <ol style="list-style-type: none"> 1. Press the left or right oval to toggle between the options.
<div style="border: 1px solid black; padding: 5px;"> MEDIA POWER UP - + </div>	<p>Select Media Power-Up Option</p> <p>This parameter sets the action of the media when you turn on the printer.</p> <p>Selections: FEED, CALIBRATION, LENGTH, and NO MOTION</p> <ul style="list-style-type: none"> • Feed—feeds the labels to the first registration point. • Calibration—determines the length of the label and adjusts the sensor settings. • Length—In continuous mode, feeds the last stored label length. In noncontinuous mode, calibrates based on the maximum label length setting (see <i>Set Maximum Label Length on page 68</i>). • No Motion—the media does not move. You must press FEED to cause the printer to resynch to the start of the next label. <p>To change the value shown:</p> <ol style="list-style-type: none"> 1. Press the left or right oval to scroll through the options.

Table 9 • Printer Parameters (Sheet 19 of 26)

Parameter	Action/Explanation
<div style="border: 1px solid black; padding: 5px;"> HEAD CLOSE - + </div>	<p>Select Head Close Option</p> <p>This parameter sets the action of the media when you close the printhead.</p> <p>Selections: FEED, CALIBRATION, LENGTH, and NO MOTION</p> <ul style="list-style-type: none"> • Feed—feeds the labels to the first registration point. • Calibration—determines the length of the label and adjusts the sensor settings. • Length—In continuous mode, feeds the last stored label length. In noncontinuous mode, calibrates based on the maximum label length setting (see <i>Set Maximum Label Length on page 68</i>). • No Motion—the media does not move. You must press FEED to cause the printer to resynch to the start of the next label. <p>To change the value shown:</p> <ol style="list-style-type: none"> 1. Press the left or right oval to scroll through the options.
<div style="border: 1px solid black; padding: 5px;"> BACKFEED - DEFAULT + </div>	<p>Select Backfeed Sequence</p> <p>This parameter sets when label backfeed occurs after a label is removed in some print modes. It has no effect in Rewind mode. This setting is superseded by ~JS when received as part of a label format (see <i>ZPL II Programming Guide Volume I</i>).</p> <p>Default: DEFAULT (90%)</p> <p>Selections: DEFAULT, AFTER, BEFORE, 10%, 20%, 30%, 40%, 50%, 60%, 70%, 80%, OFF</p> <p>To change the value shown:</p> <ol style="list-style-type: none"> 1. Press the left or right oval to scroll through the options.
<div style="border: 1px solid black; padding: 5px;"> LABEL TOP +000 - ■■■■■■■■ + </div>	<p>Adjust Label Top Position</p> <p>This parameter adjusts the print position vertically on the label. Positive numbers adjust the label top position farther down the label (away from the printhead); negative numbers adjust the position up the label (toward the printhead). The displayed value represents dots.</p> <p>Default: +000</p> <p>Range: -120 to +120 dots</p> <p>To change the value shown:</p> <ol style="list-style-type: none"> 1. Press the right oval to increase the value. 2. Press the left oval to decrease the value.

Table 9 • Printer Parameters (Sheet 20 of 26)

Parameter	Action/Explanation
<div style="border: 1px solid black; padding: 5px;"> <p>LEFT POSITION - ±0000 +</p> </div>	<p>Adjust Left Position</p> <p>This parameter establishes how far from the left edge of a label the format begins to print by adjusting horizontal positioning on the label. Positive numbers adjust the printing away from the main frame by the number of dots selected; negative numbers shift printing toward the main frame. The displayed value represents dots.</p> <p>Default: 0000</p> <p>Range: -9999 to +9999 dots</p> <p>To change the value shown:</p> <ol style="list-style-type: none"> 1. Press the left oval to move the cursor. 2. Press the right oval to change between +/- and to increase the value of the digit. 3. For a negative value, enter the value before changing to the minus sign.

Table 9 • Printer Parameters (Sheet 21 of 26)



Parameter	Action/Explanation
<div style="border: 1px solid black; padding: 5px; display: inline-block;"> HEAD TEST COUNT - 0000 + </div>	<p>Set the Head Test Count</p> <p>The printer periodically performs a test of the printhead functionality, called a printhead test or head test. This parameter establishes how many labels are printed between these internal tests.</p> <p> Note • This parameter will only appear if the Head Test Count option is installed. This option is available only on the BP-360X-Plus II.</p> <div style="border: 1px solid black; padding: 5px; margin: 10px 0;"> <pre> PRINTER CONFIGURATION Zebra Technologies ZTC 110XiIII Plus-300dpi 04.0..... DARKNESS 2 IPS..... PRINT SPEED +000..... TEAR OFF TEAR OFF..... PRINT MODE NON-CONTINUOUS..... MEDIA TYPE WEB..... SENSOR TYPE THERMAL-TRANS..... PRINT METHOD 086 08/12 MM..... PRINT WIDTH 2022..... LABEL LENGTH 39.0IN 988MM..... MAXIMUM LENGTH MEDIA DISABLED..... EARLY WARNING MAINT. OFF..... EARLY WARNING NOT CONNECTED..... USB COMM PARALLEL..... PARALLEL COMM. RS232..... SERIAL COMM. 9600..... BAUD 8 BITS..... DATA BITS NONE..... PARITY XON/XOFF..... HOST HANDSHAKE NONE..... PROTOCOL 000..... NETWORK ID NORMAL MODE..... COMMUNICATIONS <~> 7EH..... CONTROL PREFIX <^> 5EH..... FORMAT PREFIX ZPL II..... DELIMITER CHAR ZPL II..... ZPL MODE CALIBRATION..... MEDIA POWER UP CALIBRATION..... HEAD CLOSE DEFAULT..... BACKFEED +000..... LABEL TOP +000..... LEFT POSITION 0000..... HEAD TEST COUNT 0500..... HEAD RESISTOR OFF..... VERIFIER PORT OFF..... APPLICATOR PORT PULSE MODE..... START PRINT SIG FEED MODE..... RESYNCH MODE DISABLED..... REPRINT MODE 047..... WEB S. 079..... MEDIA S. 072..... RIBBON S. 050..... MARK S. 000..... MARK MED S. 003..... MEDIA LED 000..... RIBBON LED 000..... MARK LED +10..... LCD ADJUST DPSWFXM..... MODES ENABLED MODES DISABLED 1024 12/MM FULL..... RESOLUTION V48.X.X <-..... FIRMWARE V12.0.0.21..... HARDWARE ID CUSTOMIZED..... CONFIGURATION 1288..... R: RAM 2048..... E: ONBOARD FLASH NONE..... FORMAT CONVERT 007 POWER SUPPLY... P31 INTERFACE 004 DISPLAY..... P32 INTERFACE FW VERSION..... TWINAX/COAX ID 00/00/00..... IDLE DISPLAY 18:19..... RTC DATE 18:19..... RTC TIME DYNAMIC..... IP RESOLUTION ALL..... IP PROTOCOL 010.003.004.095..... IP ADDRESS 255.255.255.000..... SUBNET MASK 010.003.004.001..... DEFAULT GATEWAY FIRMWARE IN THIS PRINTER IS COPYRIGHTED </pre> </div> <p style="text-align: right; margin-top: 10px;">  If the Head Test Option is installed, HEAD TEST COUNT will be listed. </p> <p>Default: 0000 (disables the test) Range: 0000 to 9999</p> <p>To set the number of labels to print between head tests:</p> <ol style="list-style-type: none"> 1. Press the left oval to move to the next digit position. 2. Press the right oval to increase the value of the digit.

Table 9 • Printer Parameters (Sheet 22 of 26)



Parameter	Action/Explanation
	<p>Set the Printhead Resistor Value</p> <p>Caution • This parameter should be changed only by qualified service personnel. Do not set the value higher than that shown on the printhead. Setting a higher value may damage the printhead.</p> <p>This value is preset at the factory to match the resistance value of the printhead. It does not need to be changed unless the printhead or the main logic board is replaced.</p> <p>Initial Value: Factory-set to match the printhead shipped with your printer. Default Value: 0500 Range: 0488 to 2000</p> <p>To set the printhead resistor value:</p> <ol style="list-style-type: none"> 1. Before replacing the printhead, look for the label that shows the resistance value (Ω value) of the new printhead. Make note of this setting before installing the new printhead. 2. Press the left oval to move to the next digit position. 3. Press the right oval to increase the value of the digit.
	<p>Set the Verifier Port</p> <p>The auxiliary port is used to determine how the printer reacts to an online verifier. For more information on the operation of the optional verifier, refer to the documentation provided with that option.</p> <p>Default: OFF</p> <p>Selections: OFF, VER-RPRNT ERR, VER-THRUPUT</p> <ul style="list-style-type: none"> • OFF: The verifier port is off. • VER-RPRNT ERR: Label reprinted if verifier detects an error. If a bar code is near the upper edge of the label, the label is fed out far enough to be verified and then backfed to allow the next label to be printed and verified. • VER-THRUPUT: Allows greatest throughput but may not indicate a verification error immediately upon detection. May print from one to three labels before an error is recognized and printing stops. <p>To change the value shown:</p> <ol style="list-style-type: none"> 1. Press the left or right oval to scroll through the options.

Table 9 • Printer Parameters (Sheet 23 of 26)

Parameter	Action/Explanation
<div style="border: 1px solid black; padding: 5px; text-align: center;"> APPLICATOR PORT - OFF + </div>	<p>Set Applicator Port Mode Determines the action of the applicator port.</p> <p> Note • Set this value as suggested by the applicator manufacturer.</p> <p>Default: OFF</p> <p>Selections: OFF, MODE 1, MODE 2, MODE 3, MODE 4</p> <ul style="list-style-type: none"> • OFF: The applicator port is off. • MODE 1: Asserts the ~END_PRINT signal low while the printer is moving the label forward. • MODE 2: Asserts the ~END_PRINT signal high while the printer is moving the label forward. • MODE 3: Asserts the ~END_PRINT signal low for 20 milliseconds when a label has been completed and positioned. Not asserted during continuous printing modes. • MODE 4: Asserts the ~END_PRINT signal high for 20 milliseconds when a label has been completed and positioned. Not asserted during continuous printing modes. <p>To change the value shown:</p> <ol style="list-style-type: none"> 1. Press the left or right oval to scroll through the options.
<div style="border: 1px solid black; padding: 5px; text-align: center;"> START PRINT SIG - PULSE MODE + </div>	<p>Select Start Print Signal This parameter determines how the printer reacts to the Start Print Signal input on pin 3 of the applicator interface connector at the rear of the printer.</p> <p>Caution • Start Print Signal is set by the applicator manufacturer and should not be changed unless the factory defaults have been reloaded. Please make a note of it. While other choices are valid, the printer must be returned to its designated setting for it to work properly.</p> <p>Default: PULSE MODE</p> <p>Selections: PULSE MODE, LEVEL MODE</p> <ul style="list-style-type: none"> • PULSE MODE—Labels print when the signal transitions from HIGH to LOW. • LEVEL MODE—Labels print as long as the signal is asserted LOW. <p>To change the value shown:</p> <ol style="list-style-type: none"> 1. Press the left or right oval to toggle between the options.

Table 9 • Printer Parameters (Sheet 24 of 26)

Parameter	Action/Explanation
<div style="border: 1px solid black; padding: 2px;"> RESYNCH MODE - FEED MODE + </div>	<p>Select Resynch Mode</p> <p>This parameter determines how the printer reacts if the label synchronization is lost and the label top is not where expected.</p> <p>Default: FEED MODE</p> <p>Selections: FEED MODE, ERROR MODE</p> <ul style="list-style-type: none"> • FEED MODE—If the label top is not where expected, the printer feeds a blank label to find the label top position. • ERROR MODE—If the label top is not where expected, the printer stops, enters Pause mode, displays the message Error Condition Feed Label1, flashes the ERROR light, and asserts the Service Required signal (pin 10 on the Applicator Interface Connector). <p>To resynch the media to the top of the label in Error mode, press PAUSE to exit Pause mode. The ERROR light stops flashing, and the Service Required signal is deactivated. The action of the printer is determined by the Head Close configuration selection (see Select Head Close Option on page 82).</p> <p>To change the value shown:</p> <ol style="list-style-type: none"> 1. Press the left or right oval to toggle between the options.
<div style="border: 1px solid black; padding: 2px;"> WEB S. 073 - ■■■■■■ + </div>	<p>These parameters are automatically set during the calibration procedure and should be changed only by a qualified service technician. Refer to the <i>ZPL II Programming Guide</i> for information on these parameters.</p> <p>To skip these parameters:</p> <ol style="list-style-type: none"> 1. Press NEXT/SAVE repeatedly.
<div style="border: 1px solid black; padding: 2px;"> MEDIA S. 075 - ■■■■■■ + </div>	
<div style="border: 1px solid black; padding: 2px;"> RIBBON S. 071 - ■■■■■■ + </div>	
<div style="border: 1px solid black; padding: 2px;"> TAKE LABEL - ■■■■■■ + </div>	
<div style="border: 1px solid black; padding: 2px;"> MARK S. 000 - ■ + </div>	
<div style="border: 1px solid black; padding: 2px;"> MARK MED S. 000 - ■ + </div>	
<div style="border: 1px solid black; padding: 2px;"> MEDIA LED 082 - ■ + </div>	
<div style="border: 1px solid black; padding: 2px;"> RIBBON LED 008 - ■ + </div>	
<div style="border: 1px solid black; padding: 2px;"> MARK LED 005 - ■ + </div>	

Table 9 • Printer Parameters (Sheet 25 of 26)







Parameter	Action/Explanation
	<p>Adjust LCD Display This parameter allows you to adjust the brightness of your LCD if it is difficult to read.</p> <p>Default: 10 Range: 00 to 19</p> <p>To change the value shown:</p> <ol style="list-style-type: none"> 1. Press the right oval to increase the value (increase brightness). 2. Press the left oval to decrease the value (reduce brightness).
	<p>Select Format Convert Selects the bitmap scaling factor. The first number is the original dots per inch (dpi) value; the second, the dpi to which you would like to scale.</p> <p>Default: NONE Selections: NONE, 150 → 300, 150 → 600, 200 → 600, 300 → 600</p> <p>To change the value shown:</p> <ol style="list-style-type: none"> 1. Press the left or right oval to scroll through the options.
	<p>Select Idle Display This parameter selects the LCD options for the real-time clock.</p> <p> Note • If the default value is not selected, pressing the left or right oval briefly displays the firmware version of the printer.</p> <p>Default: FIRMWARE VERSION Selections: MM/DD/YY (24 HOUR), MM/DD/YY (12 HOUR), DD/MM/YY (24 HOUR), DD/MM/YY (12 HOUR), FW VERSION</p> <p>To change the value shown:</p> <ol style="list-style-type: none"> 1. Press the left or right oval to scroll through the options.
	<p>Set Real-Time Clock (RTC) Date This parameter allows you to set the date following the convention selected in IDLE DISPLAY.</p> <p>To change the value shown:</p> <ol style="list-style-type: none"> 1. Press the left oval to move to the next digit position. 2. Press the right oval to change the value of the digit.
	<p>Set RTC Time This parameter allows you to set the time following the convention selected in IDLE DISPLAY.</p> <p>To change the value shown:</p> <ol style="list-style-type: none"> 1. Press the left oval to move to the next digit position. 2. Press the right oval to change the value of the digit.

Table 9 • Printer Parameters (Sheet 26 of 26)

Parameter	Action/Explanation
<div style="border: 1px solid black; padding: 5px;"> LANGUAGE - ENGLISH + </div>	<p>Select the Display Language This parameter changes the language displayed on the LCD. Default: ENGLISH Selections: ENGLISH, SPANISH, FRENCH, GERMAN, ITALIAN, NORWEGIAN, PORTUGUESE, SWEDISH, DANISH, SPANISH 2, DUTCH, FINNISH, JAPAN</p> <p>To change the value shown:</p> <ol style="list-style-type: none"> 1. Press the left or right oval to scroll through the options.



Notes • _____

Print Modes

This section describes the print mode options available for the printer.

Contents

Print Modes	92
Select the Print Mode.	92
Tear-Off Mode	92
Load Media in Peel-Off Mode	93
Load Media in Cutter Mode	100
Load Media in Rewind Mode (No Cutter)	105
Load Media in Rewind Mode with Cutter Option	112
Install the Rewind Plate	119
Remove Media Liner from the Rewind or Peel Spindle	120

Print Modes

The options on your printer may let you set up print modes other than the default of Tear-Off mode. Use the control panel to set up the printer to the print mode that you wish to use.

Select the Print Mode

The following are the print mode selections available through the control panel. Some of them require that an option be purchased.

- Tear-off
- Peel-off
- Cutter
- Rewind
- Applicator (used only if a machine will apply printed labels to something)

To select a print mode, complete these steps:

1. From the control panel, press SETUP/EXIT.
2. Press NEXT/SAVE until the LCD reads **PRINT MODE**.
3. Use the right or left oval to scroll through the choices. Be sure to select a print mode that your hardware supports—some of the selections displayed are for optional printer features.
4. To save your selection, press SETUP/EXIT.

Tear-Off Mode

See [Load Media in Tear-Off Mode on page 35](#) to set up labels in Tear-Off mode.

Load Media in Peel-Off Mode

Peel-Off mode (Figure 27) advances one label at a time. The printer does not print another label until the first label is removed. The TAKE LABEL light flashes until the label is removed. The backing is wound on the rewind spindle, but the rewind plate is not used.

Figure 27 • Media Loaded in Peel-Off Mode

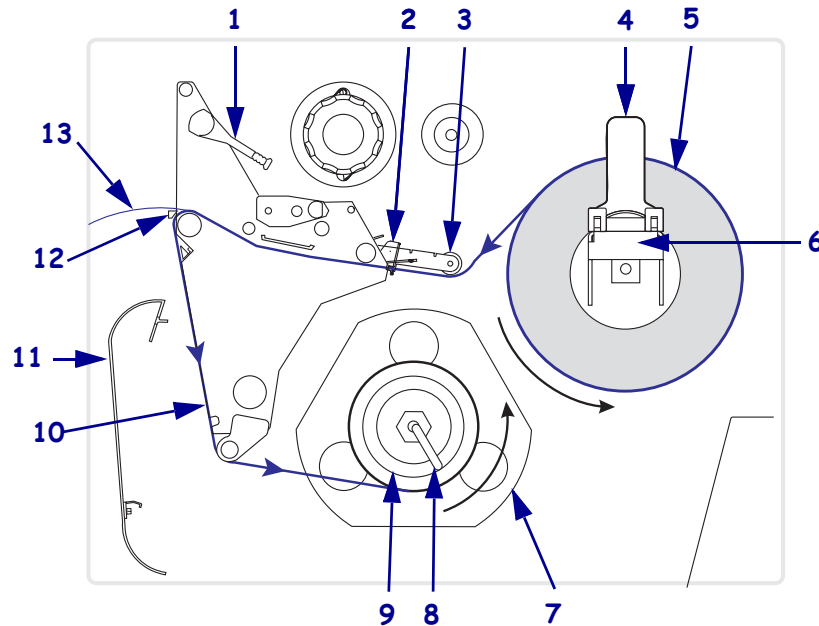

1	Printhead-open lever
2	Media guide
3	Media guide roller
4	Media supply guide
5	Media
6	Media supply hanger
7	Guide plate
8	Spindle hook
9	Rewind spindle
10	Label backing
11	Rewind plate (removed)*
12	Tear-off bar
13	Printed label

* In new printers, remove the protective plastic covering from the rewind plate before using.

Caution • While performing any tasks near an open printhead, remove all rings, watches, hanging necklaces, identification badges, or other metallic objects that could touch the printhead. You are not required to turn off the printer power when working near an open printhead, but Brady recommends it as a precaution. If you turn off the power, you will lose all temporary settings, such as label formats, and you must reload them before you resume printing.

To set up the printer in Peel-Off mode, complete these steps:

1. Remove the rewind plate (if installed) from the front of the printer. Store it on the two mounting screws on the inside of the control panel. See [Figure 31, Rewind Plate, on page 119](#) for more information.
2. Set the printer to Peel-Off mode. See [Select Print Mode on page 65](#) for instructions.
3. Insert media into the printer. See [Prepare the Media for Loading on page 32](#) for instructions.
4. Open the printhead assembly by rotating the printhead-open lever (1) counter-clockwise.

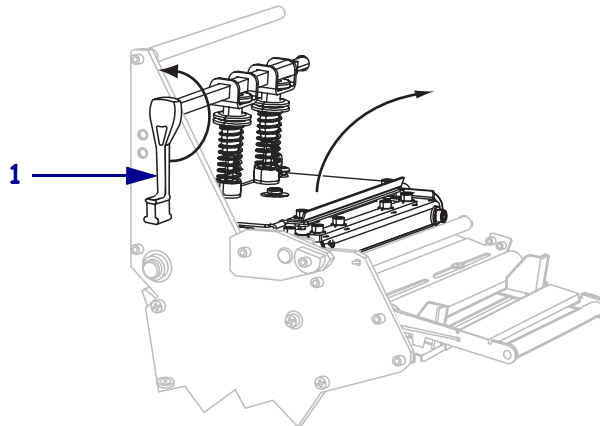

5. Loosen the thumb screw (not visible from this angle) that is located on the bottom of the outer media guide (1).

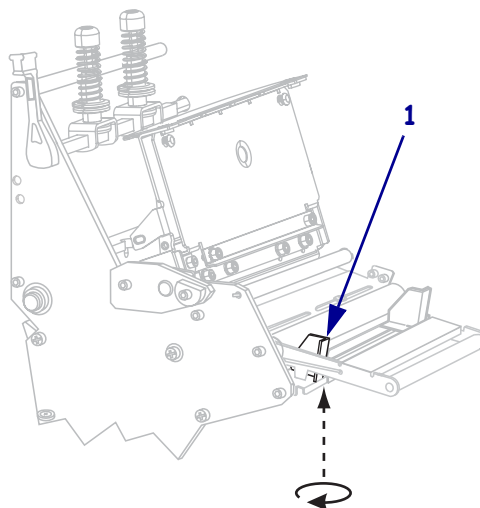

6. Slide the outer media guide (1) all the way out.

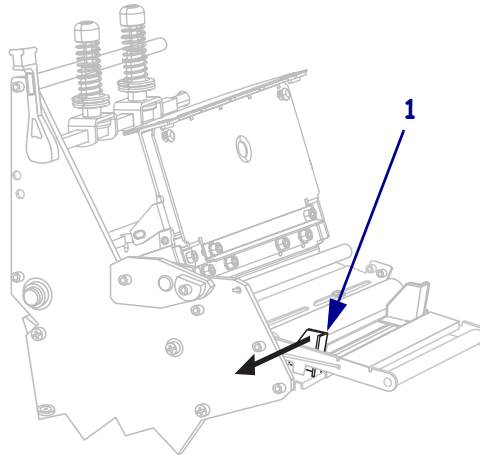

7. If your printer includes a media dancer assembly (1), thread the media under the media dancer assembly roller. For all printers, thread the media under the media guide roller (2) and then the upper media sensor (3).



Important • Make sure that you thread the media under these components. If you thread the media over the them, the media obstructs the ribbon sensor and causes a false **RIBBON OUT** error.

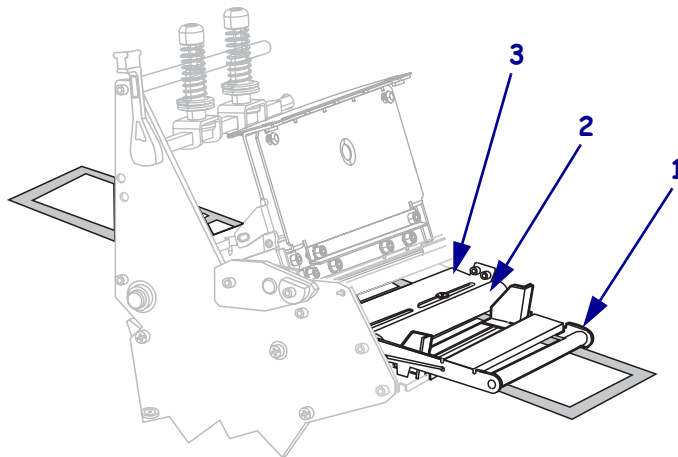

8. Push the media forward until it passes under the printhead assembly (1), under the snap plate (2), and then over the platen roller (3).

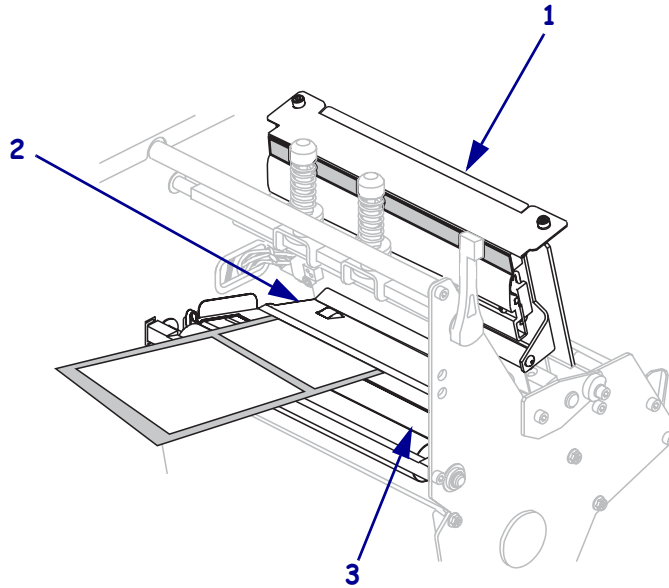

9. Extend approximately 36 in. (920 mm) of media out of the printer. Remove and discard the labels from this exposed media.

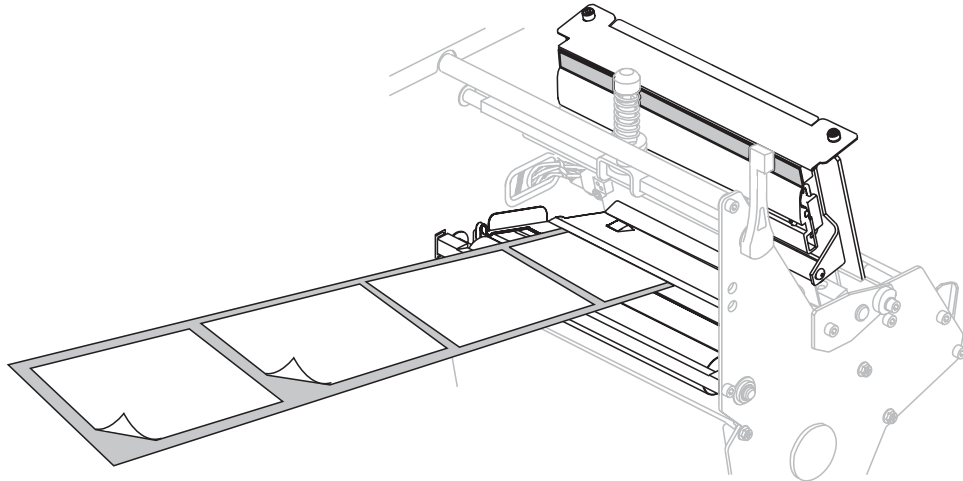

10. Remove the hook from the rewind spindle.

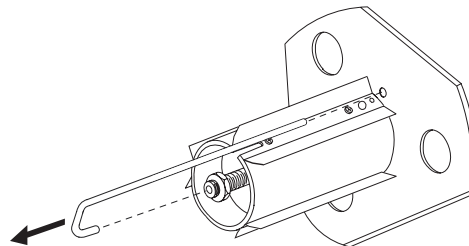

11. If you are using a core, slide it onto the rewind spindle until it is flush against the guide plate.



Note • A core is not required.

12. Wind the media liner counterclockwise around the rewind spindle.

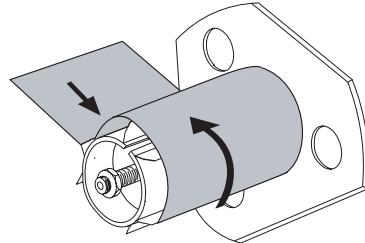

- a. Reinstall the hook. Insert the short end of the hook into the hole in the center of the adjusting nut (1). Insert the long end of the hook into the small hole on the guide plate (2).

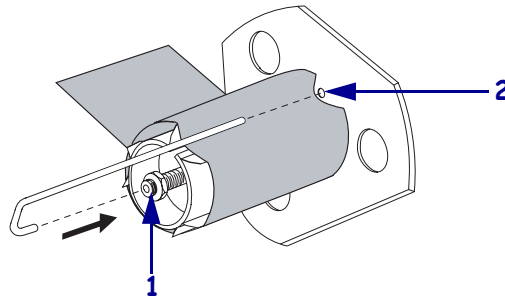

- b. Rotate the spindle counterclockwise several turns to wind the media liner over the hook and remove any slack.

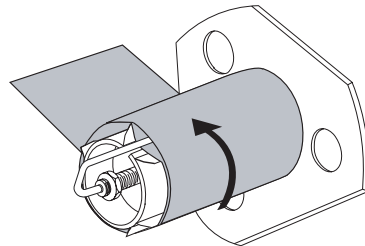

- 13.** Align the media with the inner media guide (1). Slide in the outer media guide (2) until it just touches the edge of the media.

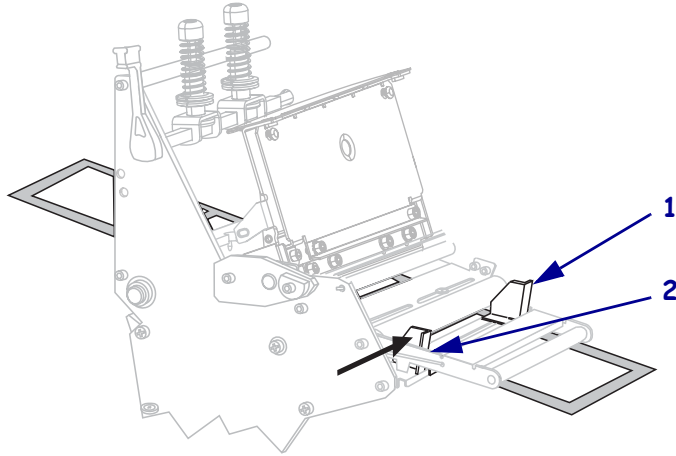

- 14.** Tighten the thumb screw (not visible from this angle) that is located on the bottom of the outer media guide (1).

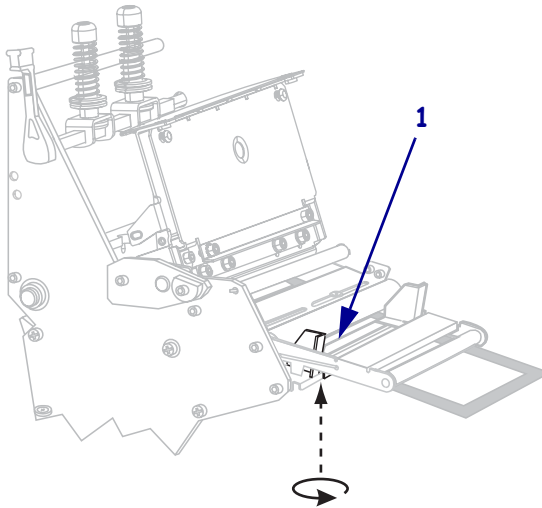

15. Push down the printhead assembly (1), and then rotate the printhead-open lever (2) clockwise until it locks into place.

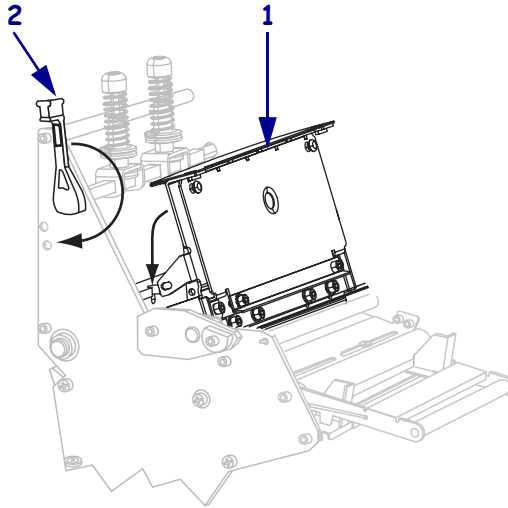

The backing winds on the rewind spindle or core.

16. For instructions for removing the backing from the rewind spindle, see [Remove Media Liner from the Rewind or Peel Spindle on page 120](#).

Load Media in Cutter Mode

A cutter is a rotating knife with a self-sharpening blade that is attached to the front of the printer. The cutter is used to cut individual labels as they are printed.

Figure 28 shows the printer loaded with labels in Cutter mode.

Figure 28 • Media Loaded in Cutter Mode

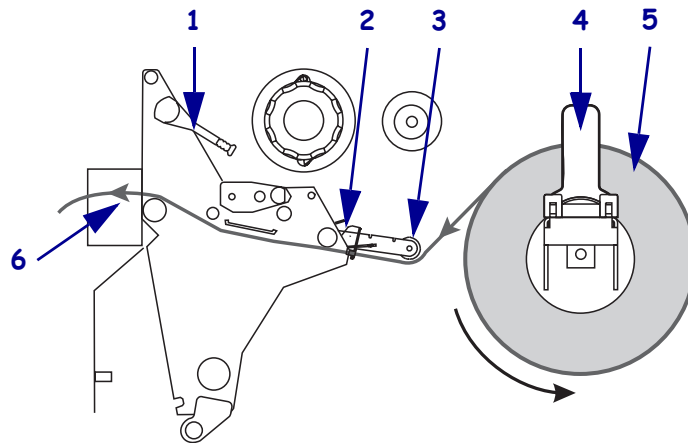

1	Printhead-open lever
2	Media guide
3	Media guide roller
4	Media supply guide
5	Media
6	Cutter

Caution • While performing any tasks near an open printhead, remove all rings, watches, hanging necklaces, identification badges, or other metallic objects that could touch the printhead. You are not required to turn off the printer power when working near an open printhead, but Brady recommends it as a precaution. If you turn off the power, you will lose all temporary settings, such as label formats, and you must reload them before you resume printing.

To set up the printer in Cutter mode, complete these steps:

1. Set the printer to Cutter mode. See [Select Print Mode on page 65](#) for instructions.
2. Insert media into the printer. See [Prepare the Media for Loading on page 32](#) for instructions.

3. Open the printhead assembly by rotating the printhead-open lever (1) counter-clockwise.

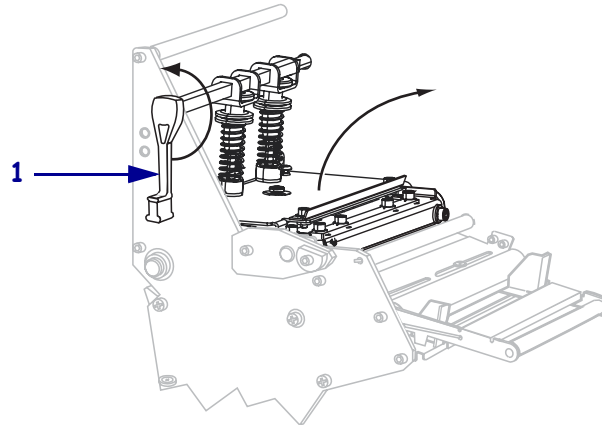

4. Loosen the thumb screw (not visible from this angle) that is located on the bottom of the outer media guide (1).

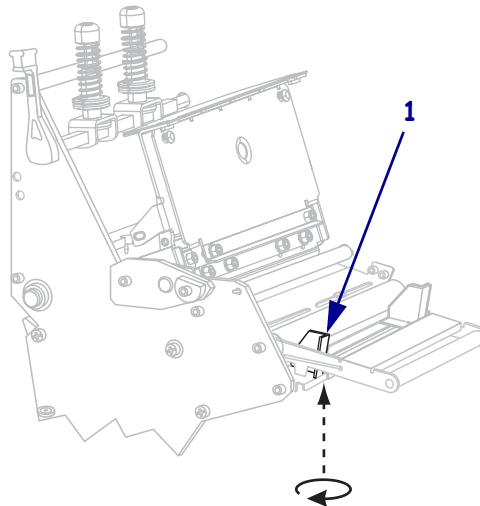

5. Slide the outer media guide (1) all the way out.

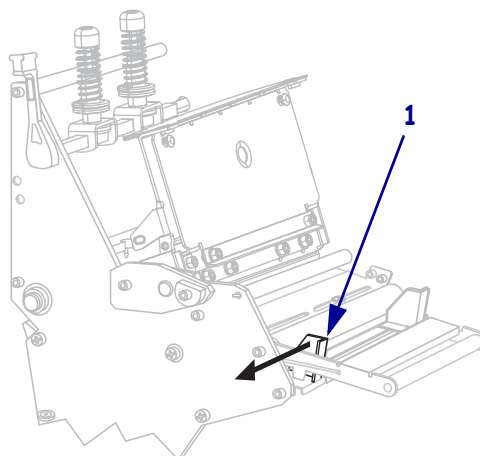

6. If your printer includes a media dancer assembly (1), thread the media under the media dancer assembly roller. For all printers, thread the media under the media guide roller (2) and then the upper media sensor (3).



Important • Make sure that you thread the media under these components. If you thread the media over the them, the media obstructs the ribbon sensor and causes a false **RIBBON OUT** error.

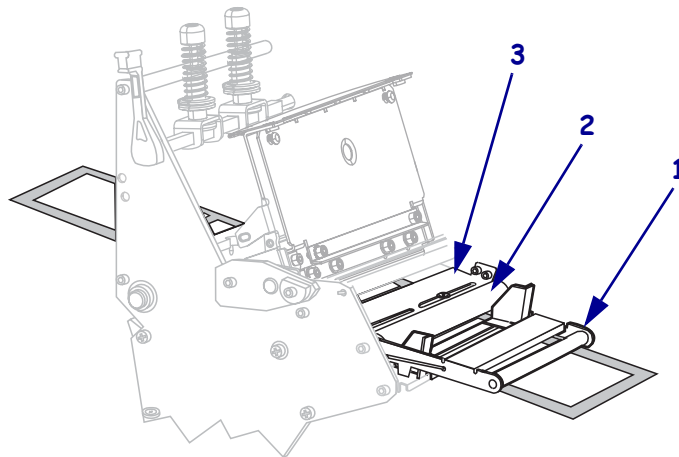

7. **Caution** • The cutter blade is sharp. Do not touch or rub the blade with your fingers.

Thread the media forward until it passes under the printhead assembly (1), under the snap plate (2), and through the cutter assembly (3).

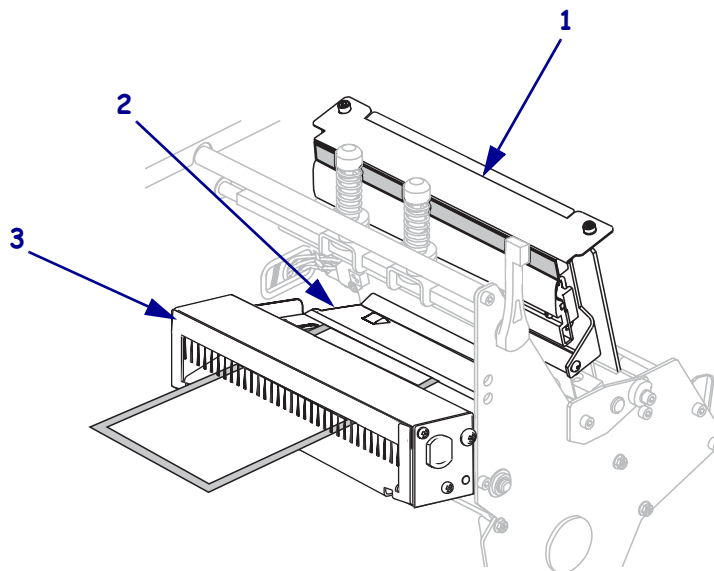

8. Align the media with the inner media guide (1). Slide in the outer media guide (2) until it just touches the edge of the media.

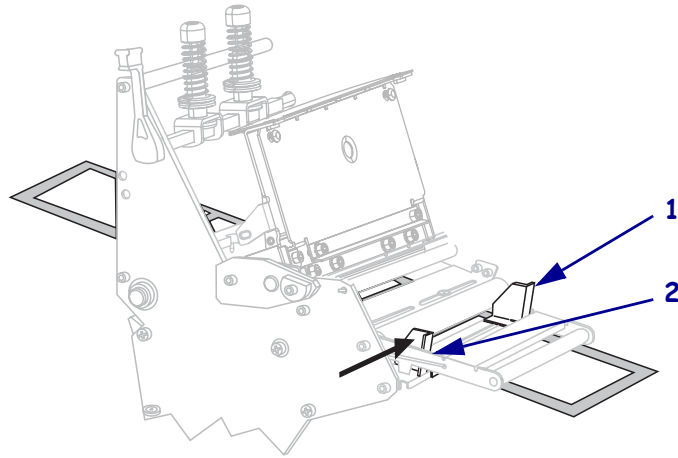

9. Tighten the thumb screw (not visible from this angle) that is located on the bottom of the outer media guide (1).

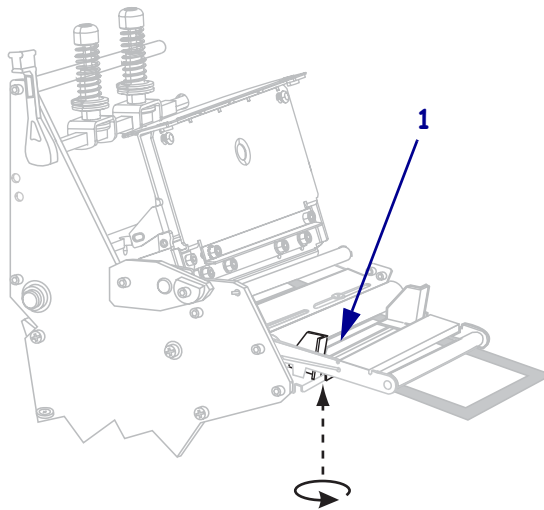

10. Push down the printhead assembly (1), and then rotate the printhead-open lever (2) clockwise until it locks into place.

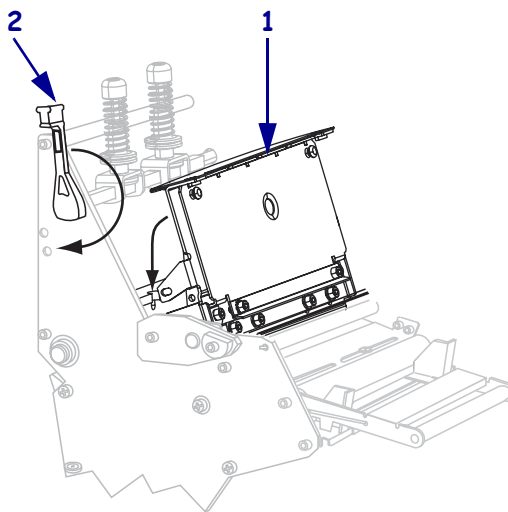

Load Media in Rewind Mode (No Cutter)

Rewind mode (Figure 29) allows the media to be wound on a core after printing. This section shows how to load media for Rewind mode in printers that do not have a Cutter option.

Figure 29 • Media Loaded in Rewind Mode

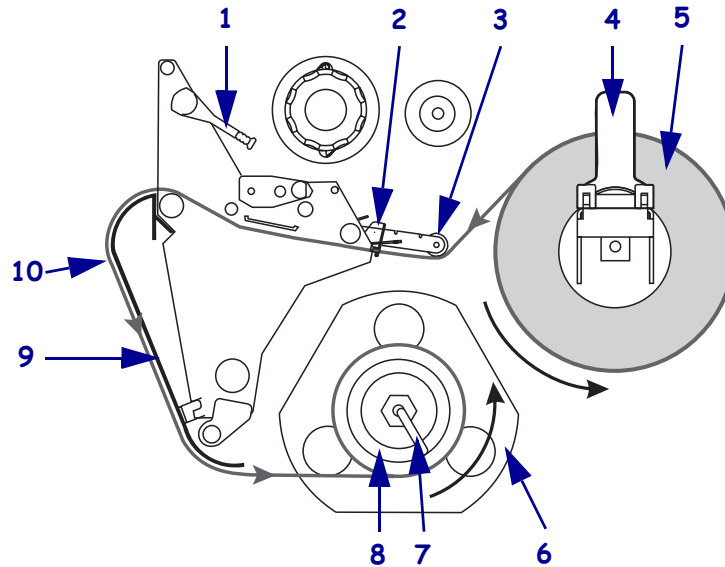

1	Printhead-open lever
2	Media guide
3	Media guide roller
4	Media supply guide
5	Labels
6	Guide plate
7	Spindle hook
8	Rewind spindle
9	Rewind plate (for Rewind mode only)*
10	Printed labels

* In new printers, remove the protective plastic covering from the rewind plate before using.

Caution • While performing any tasks near an open printhead, remove all rings, watches, hanging necklaces, identification badges, or other metallic objects that could touch the printhead. You are not required to turn off the printer power when working near an open printhead, but Brady recommends it as a precaution. If you turn off the power, you will lose all temporary settings, such as label formats, and you must reload them before you resume printing.

To set up the printer in Rewind mode, complete these steps:

1. If you have not already done so, install the rewind plate. See [Install the Rewind Plate on page 119](#) for instructions.
2. Set the printer to Rewind mode. See [Select Print Mode on page 65](#) for instructions.
3. Insert media into the printer. See [Prepare the Media for Loading on page 32](#) for instructions.
4. Open the printhead assembly by rotating the printhead-open lever (1) counter-clockwise.

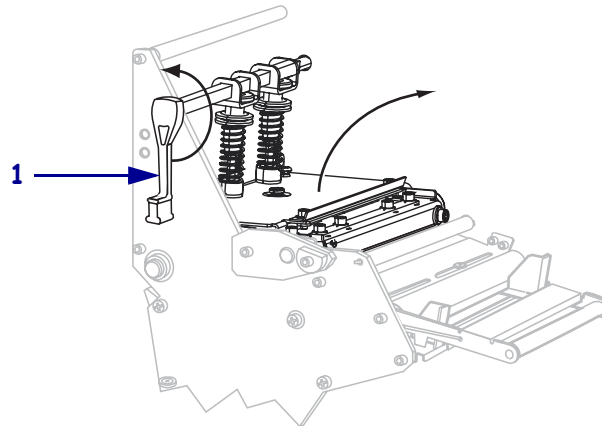

5. Loosen the thumb screw (not visible from this angle) that is located on the bottom of the outer media guide (1).

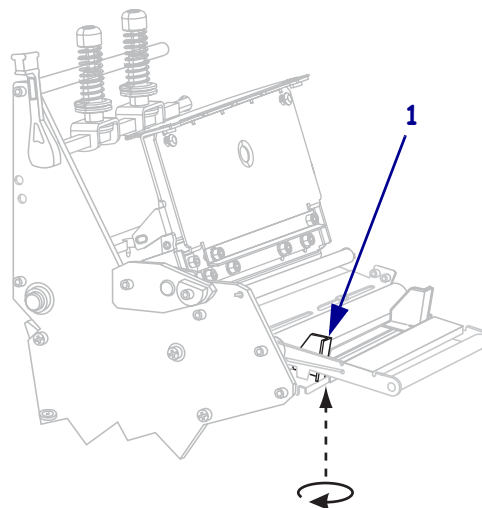

6. Slide the outer media guide (1) all the way out.

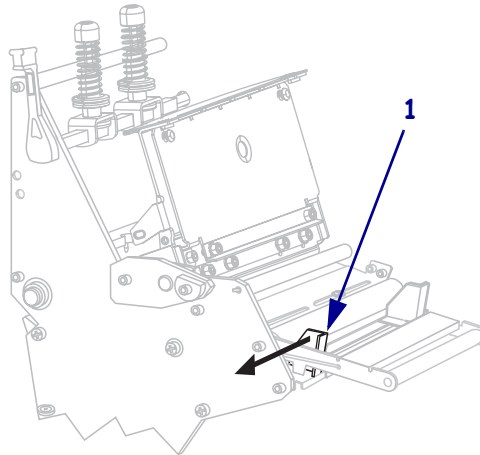

7. If your printer includes a media dancer assembly (1), thread the media under the media dancer assembly roller. For all printers, thread the media under the media guide roller (2) and then the upper media sensor (3).



Important • Make sure that you thread the media under these components. If you thread the media over the them, the media obstructs the ribbon sensor and causes a false **RIBBON OUT** error.

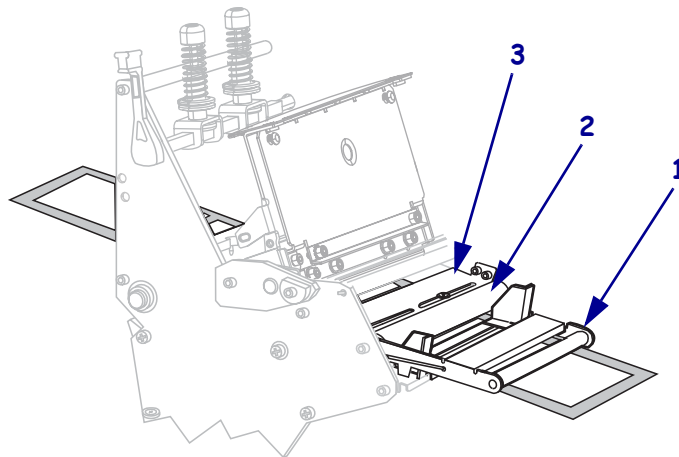

8. Push the media forward until it passes under the printhead assembly (1), under the snap plate (2), and then over the platen roller (3).

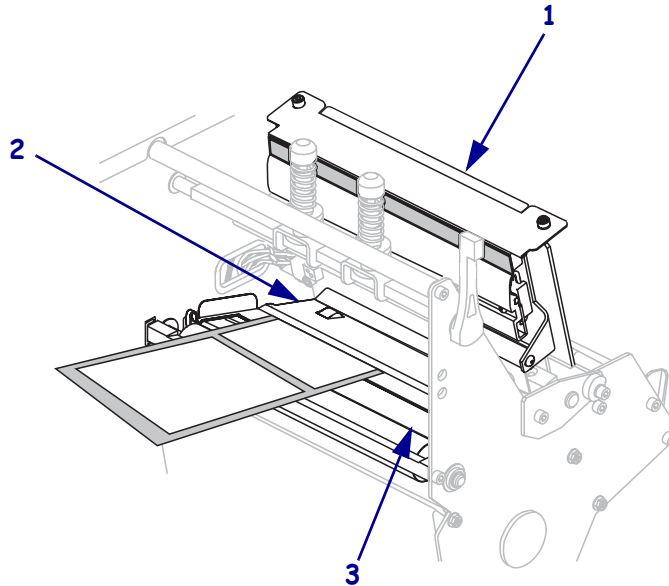

9. Extend approximately 36 in. (920 mm) of media out of the printer. Remove and discard the labels from this exposed media.

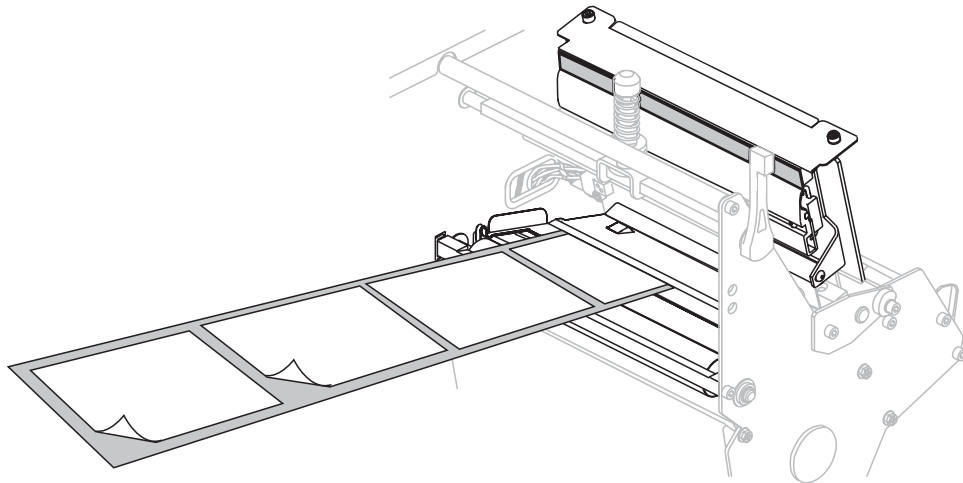

10. Remove the hook from the rewind spindle.

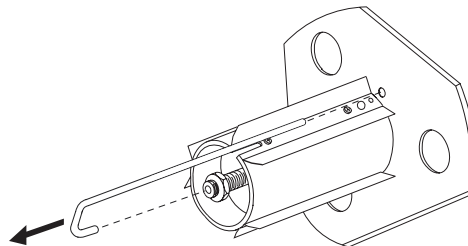

11. If you are using a core, slide it onto the rewind spindle until it is flush against the guide plate.



Note • A core is not required.

12. Wind the media liner counterclockwise around the rewind spindle.

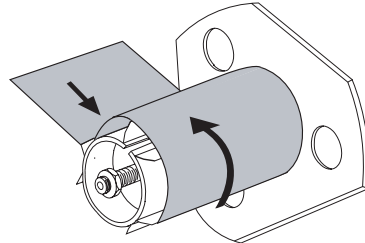

13. Reinstall the hook. Insert the short end of the hook into the hole in the center of the adjusting nut (1). Insert the long end of the hook into the small hole on the guide plate (2).

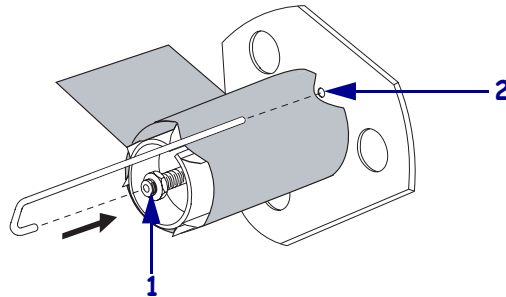

14. Rotate the spindle counterclockwise several turns to wind the media liner over the hook and remove any slack.

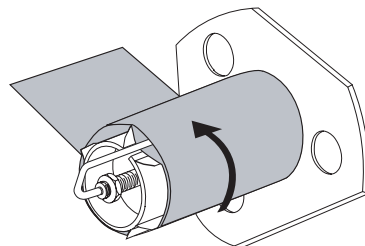

15. Align the media with the inner media guide (1). Slide in the outer media guide (2) until it just touches the edge of the media.

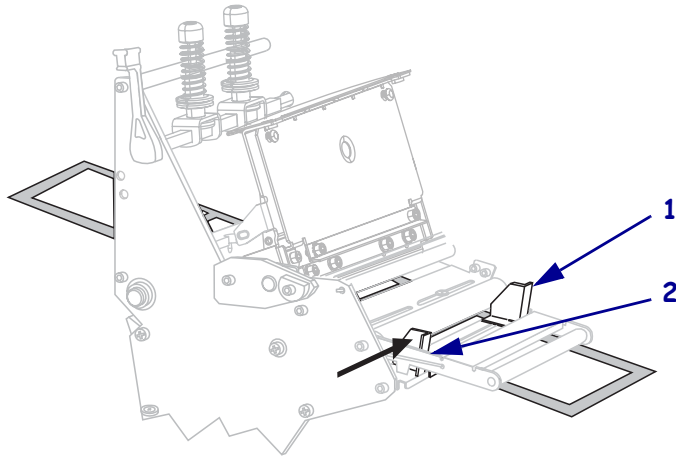

16. Tighten the thumb screw (not visible from this angle) that is located on the bottom of the outer media guide (1).

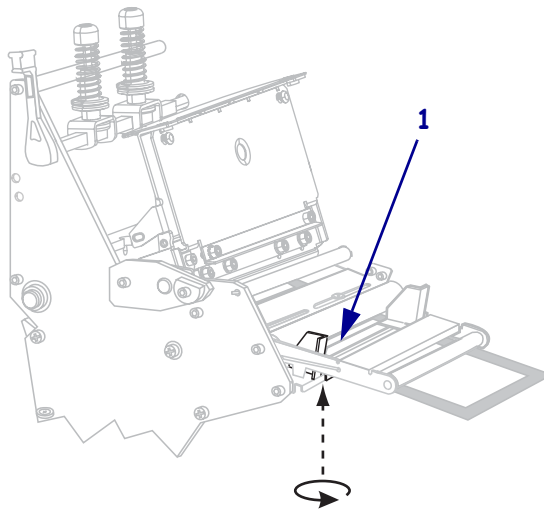

17. Push down the printhead assembly (1), and then rotate the printhead-open lever (2) clockwise until it locks into place.

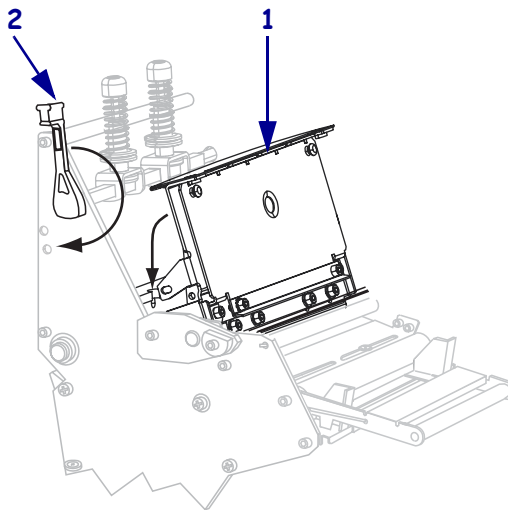

The labels wind on the rewind spindle or core.

Load Media in Rewind Mode with Cutter Option

Some printers with the Cutter option can use Rewind mode to print and save a roll of labels (Figure 30). This section shows how to load media for Rewind mode in printers that have a Cutter option.



Note • Rewind mode cannot be used with the Cutter option on the 300X-Plus II and 600X-Plus II.

Figure 30 • Media Loaded in Rewind Mode with Cutter Option

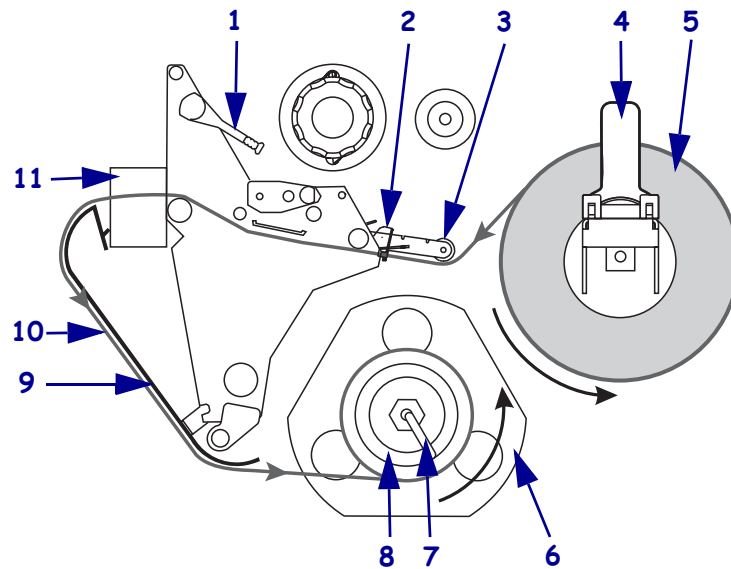

1	Printhead-open lever
2	Media guide
3	Media guide roller
4	Media supply guide
5	Labels
6	Guide plate
7	Spindle hook
8	Rewind spindle
9	Rewind plate for Rewind mode with Cutter option*
10	Printed label
11	Cutter

* In new printers, remove the protective plastic covering from the rewind plate before using.

Caution • While performing any tasks near an open printhead, remove all rings, watches, hanging necklaces, identification badges, or other metallic objects that could touch the printhead. You are not required to turn off the printer power when working near an open printhead, but Brady recommends it as a precaution. If you turn off the power, you will lose all temporary settings, such as label formats, and you must reload them before you resume printing.

To set up the Rewind mode for printers with the cutter option, complete these steps:

1. If you have not already done so, install the rewind plate. See [Install the Rewind Plate on page 119](#) for instructions.
2. Set the printer to Rewind mode. See [Select Print Mode on page 65](#) for instructions.
3. Insert media into the printer. See [Prepare the Media for Loading on page 32](#) for instructions.
4. Open the printhead assembly by rotating the printhead-open lever (1) counter-clockwise.

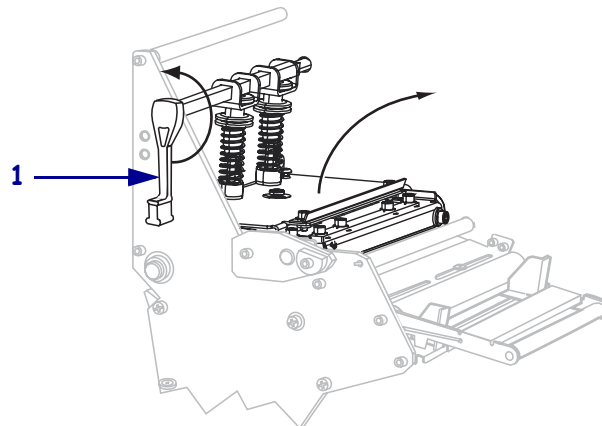

5. Loosen the thumb screw (not visible from this angle) that is located on the bottom of the outer media guide (1).

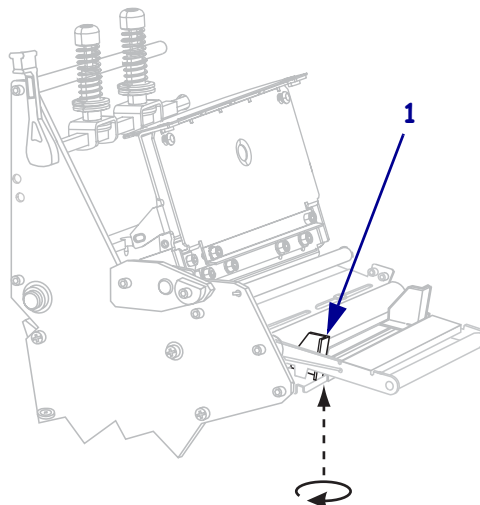

6. Slide the outer media guide (1) all the way out.

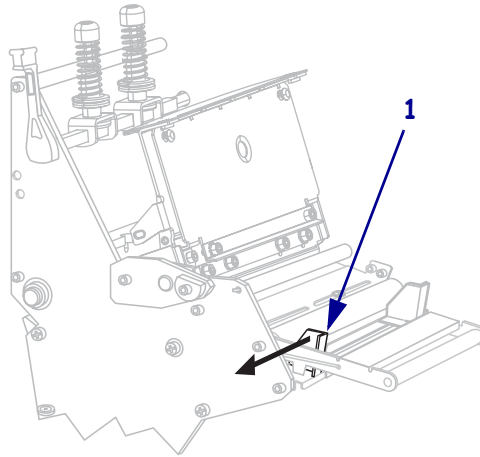

7. If your printer includes a media dancer assembly (1), thread the media under the media dancer assembly roller. For all printers, thread the media under the media guide roller (2) and then the upper media sensor (3).



Important • Make sure that you thread the media under these components. If you thread the media over the them, the media obstructs the ribbon sensor and causes a false **RIBBON OUT** error.

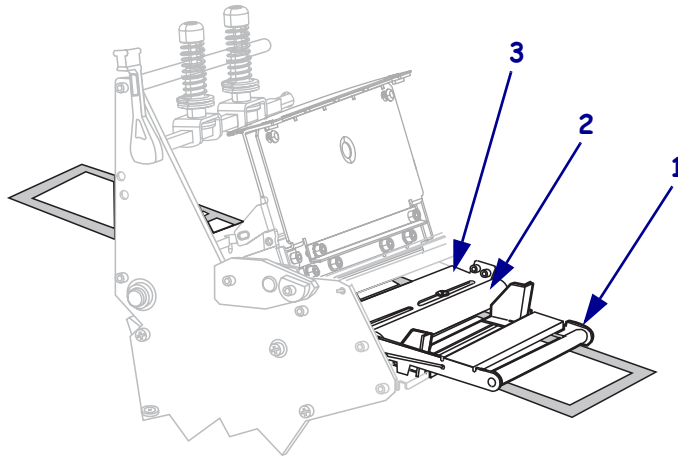



8. **Caution** • The cutter blade is sharp. Do not touch or rub the blade with your fingers.

Thread the media forward until it passes under the printhead assembly (1), under the snap plate (2), and through the cutter assembly (3).

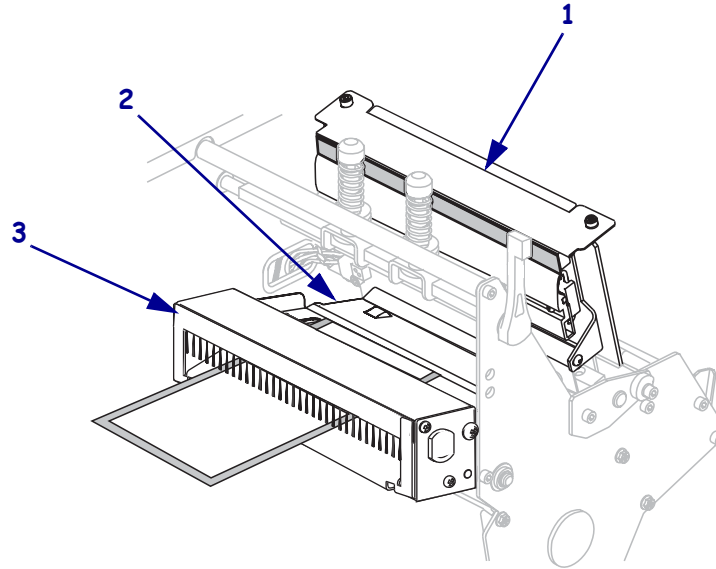

9. Extend approximately 36 in. (920 mm) of media out of the printer. Remove and discard the labels from this exposed media.

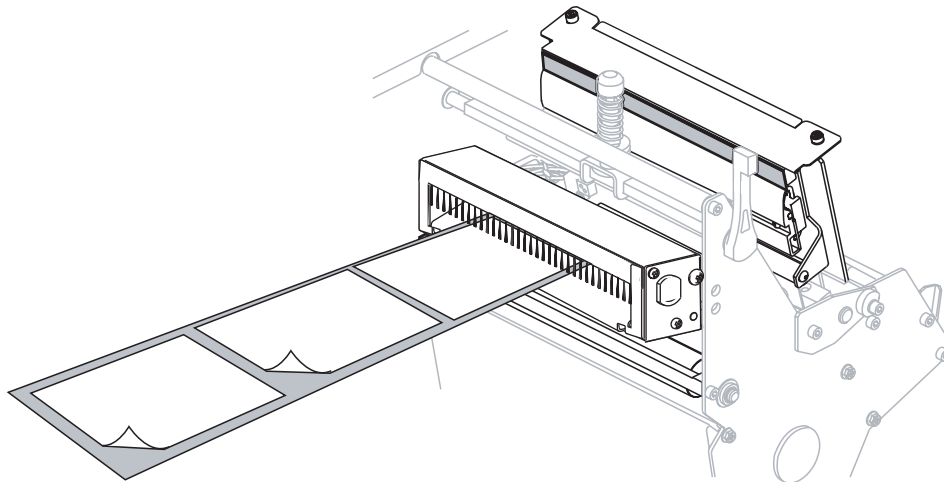

10. Remove the hook from the rewind spindle.

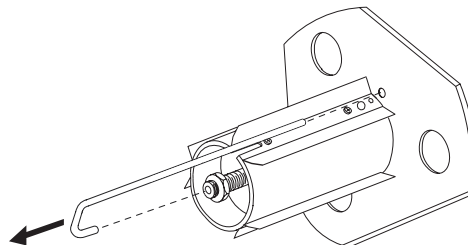

11. If you are using a core, slide it onto the rewind spindle until it is flush against the guide plate.



Note • A core is not required.

12. Wind the media liner counterclockwise around the rewind spindle.

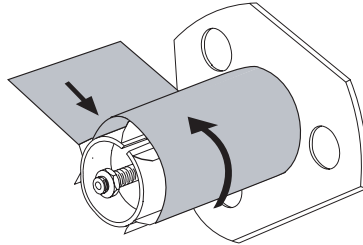

13. Reinstall the hook. Insert the short end of the hook into the hole in the center of the adjusting nut (1). Insert the long end of the hook into the small hole on the guide plate (2).

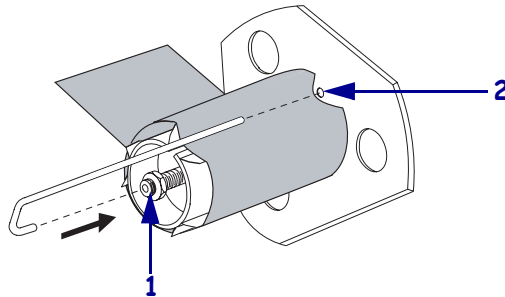

14. Rotate the spindle counterclockwise several turns to wind the media liner over the hook and remove any slack.

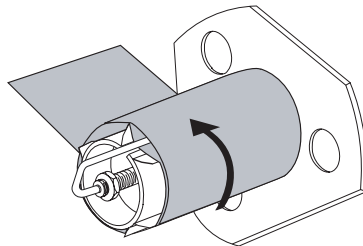

15. Align the media with the inner media guide (1). Slide in the outer media guide (2) until it just touches the edge of the media.

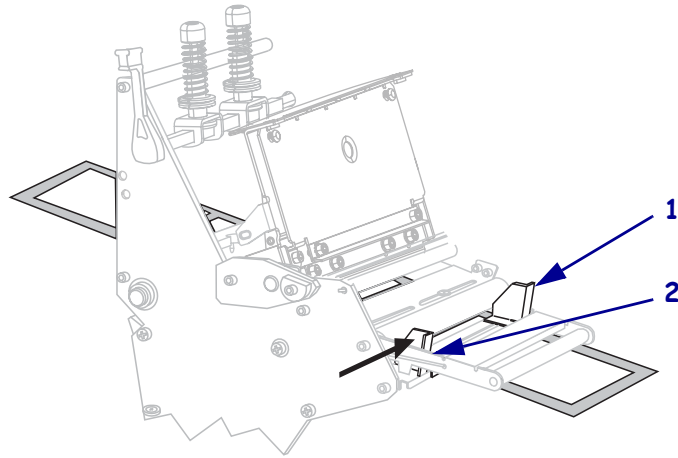

16. Tighten the thumb screw (not visible from this angle) that is located on the bottom of the outer media guide (1).

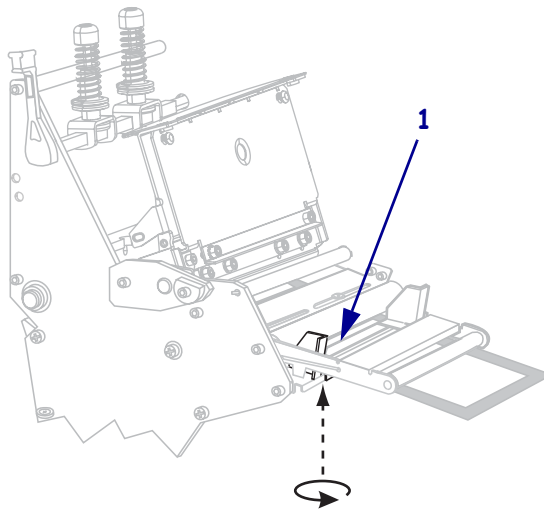

17. Push down the printhead assembly (1), and then rotate the printhead-open lever (2) clockwise until it locks into place.

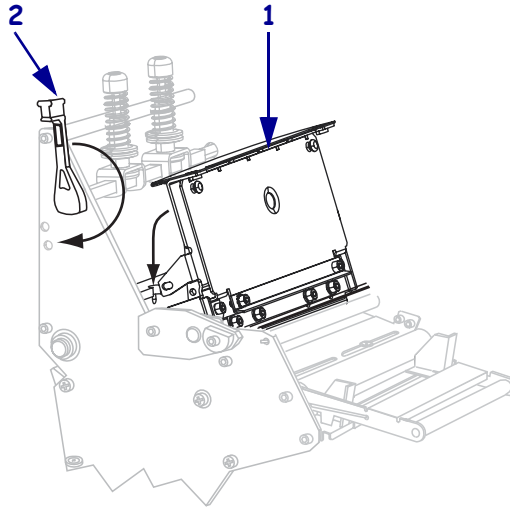

The labels wind on the rewind spindle or core.

18. For instructions for removing the labels from the rewind spindle, see [Remove Media Liner from the Rewind or Peel Spindle](#) on page 120.

Install the Rewind Plate

To install the rewind plate, complete these steps:

1. Remove the rewind plate from its storage location inside the printer.
2. See [Figure 31](#). Position the rewind plate so that the lip on the attached hook plate points down.

Figure 31 • Rewind Plate

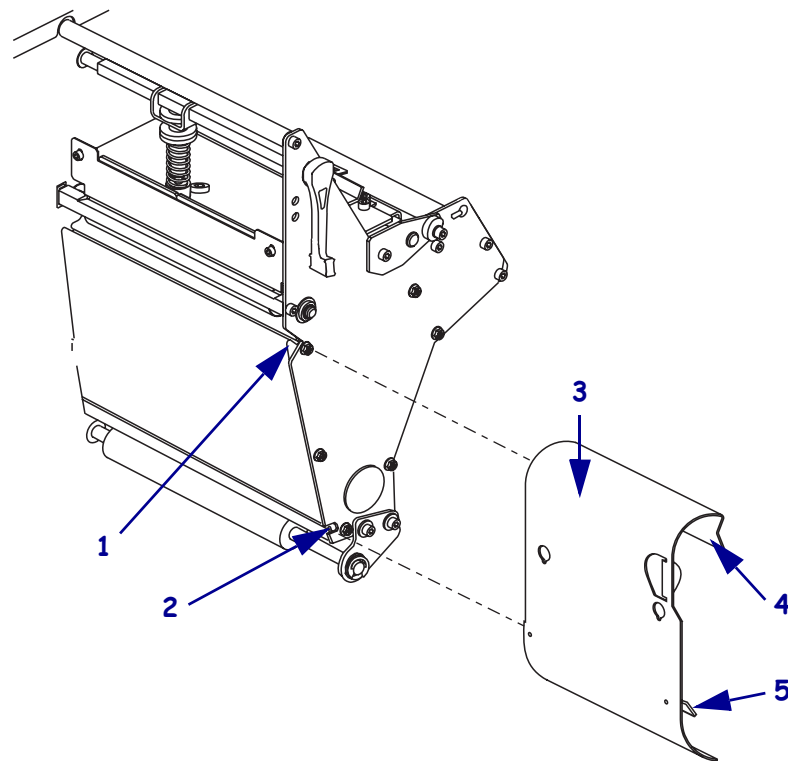

1	Upper slot
2	Lower slot
3	Rewind plate
4	Lip
5	Adjustable hook plate

3. Insert the hook plate lip 1/2 in. (13 mm) into the lower slot in the side plate.
4. Align the upper end of the rewind plate with the matching upper slot in the side plate.
5. Slide in the rewind plate until it stops against the printer's main frame.

Remove Media Liner from the Rewind or Peel Spindle

Rewind mode and Peel-Off mode each use spindles to wind used media liner. Remove the media liner from the spindle each time that you change labels.



Important • It is **not** necessary to turn off the power to remove media liner from the spindle. If power is turned off, all label formats and images, as well as any temporarily saved parameter settings stored in the printer's internal memory, are lost. When power is turned back on, these items must be reloaded.

To remove media liner from the rewind or peel spindle, complete these steps:

1. Has the media run out?

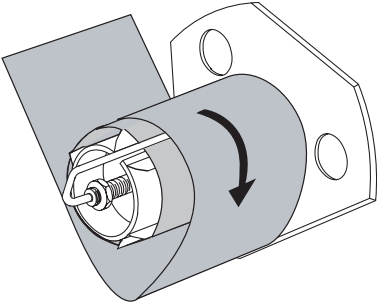
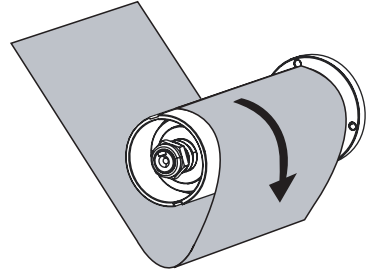
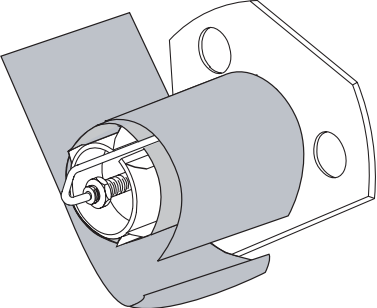
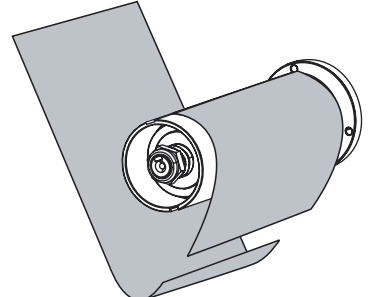
If...	Then...
No	<p>a. Create slack in the media liner by rotating the spindle slightly clockwise.</p> <div style="display: flex; justify-content: space-around; align-items: center;"> <div style="text-align: center;"> <p>Rewind</p>  </div> <div style="text-align: center;"> <p>Peel</p>  </div> </div> <p>b. Cut or tear the media liner at the spindle.</p> <div style="display: flex; justify-content: space-around; align-items: center;"> <div style="text-align: center;"> <p>Rewind</p>  </div> <div style="text-align: center;"> <p>Peel</p>  </div> </div>
Yes	Continue with the next step.

2. Pull out the spindle hook.

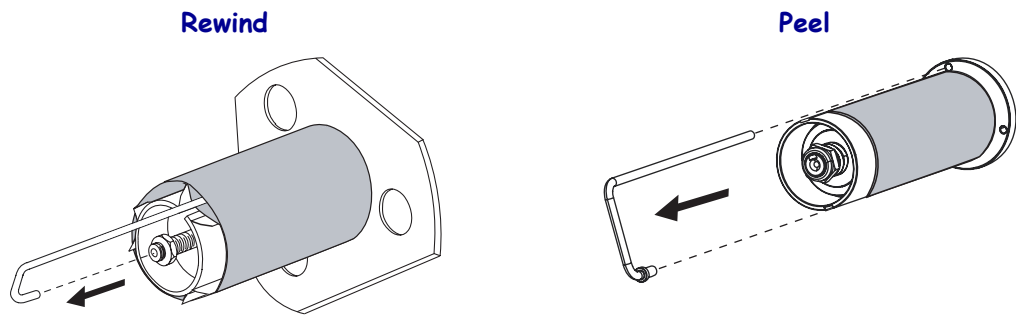

3. Slide the media liner off of the spindle and discard.

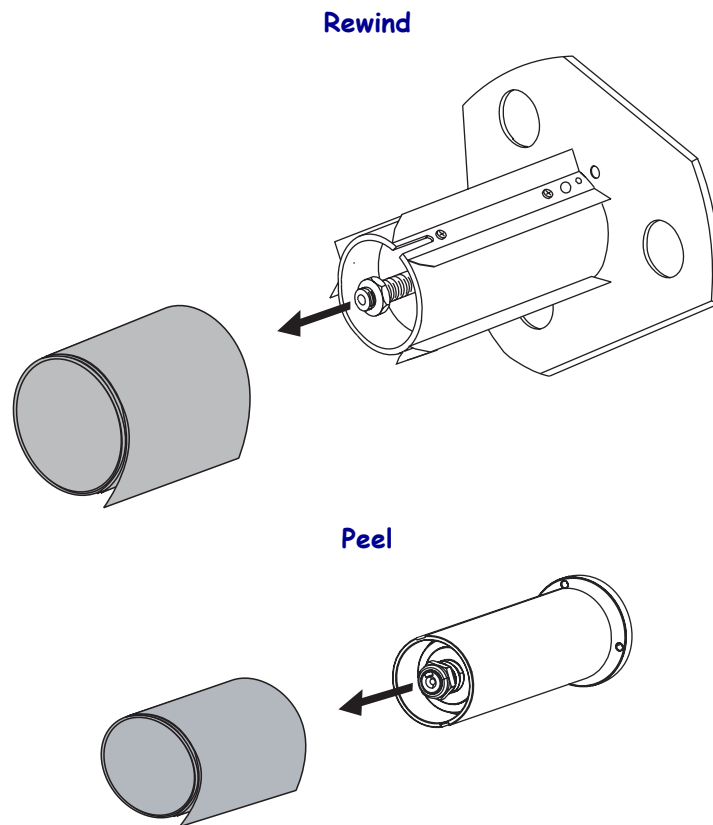



Notes • _____

Routine Maintenance

This section provides routine cleaning and maintenance procedures.

Contents

Cleaning Schedule	124
Clean the Exterior	125
Clean the Media Compartment	125
Clean the Printhead and Platen Roller	125
Clean the Sensors	128
Ribbon and Label-Available Sensor Locations	128
Transmissive (Media) Sensor Locations	130
Clean the Snap Plate	131
Clean the Cutter	133
Replace the Fuse (360X-Plus II Only)	134

Cleaning Schedule

Cleaning your printer regularly maintains print quality and may extend the life of the printer. The recommended cleaning schedule is shown in [Table 10](#). See the following pages for specific procedures.

Caution • Use only the cleaning agents indicated. Brady is not responsible for damage caused by any other fluids being used on this printer.

Table 10 • Recommended Printer Cleaning Schedule

Area	Method	Interval
Printhead	Solvent*	Perform these procedures at the following times: <ul style="list-style-type: none"> • When CLEAN HEAD NOW appears. • Direct Thermal Print Mode: After every roll of labels or 500 ft (150 m) of fanfold labels. • Thermal Transfer Print Mode: After every roll (1500 ft or 450 m) of ribbon.
Platen roller	Solvent*	
Transmissive (media) sensor	Air blow†	
Black mark sensor	Air blow†	
Media path	Solvent*	
Ribbon sensor	Air blow	
Label-available sensors	Air blow	Every 6 months, or as needed
Tear-off/peel-off bar	Solvent*	As needed
Snap plate	Solvent*	
Cutter	Solvent*	

* Brady recommends using Preventive Maintenance Kit (part number PCK-4). In place of this kit, you may use a clean swab dipped in a solution of isopropyl alcohol (minimum 90%) and deionized water (maximum 10%).

† If using canned air, it is recommended that you turn off the printer before cleaning.

Clean the Exterior

Clean the outside surfaces of the printer with a lint-free cloth. Use a mild detergent solution or desktop cleaner sparingly, as needed.

Caution • Do not use harsh or abrasive cleaning agents or solvents.

Clean the Media Compartment

After every four rolls of media, inspect the media compartment. Use a soft bristle brush or a vacuum cleaner to remove any dirt and lint from the interior of the printer.

Clean the Printhead and Platen Roller

Cleaning intervals are as follows, based on the printhead resolution:

For 300 dpi printers Clean the printhead after every roll (1500 feet or 450 m) of thermal transfer ribbon or after every roll (500 feet or 150 m) of direct thermal labels or when **CLEAN HEAD NOW** appears on the LCD. Clean the printhead more often if you see inconsistent print quality, such as voids in the bar code or graphics.

For 600 dpi printers Clean the printhead after each roll (500 feet or 150 m) of labels or when **CLEAN HEAD NOW** appears on the LCD. Clean the printhead more often if you see inconsistent print quality, such as voids in the bar code or graphics.



Note • You do not need to turn off the printer before cleaning the printhead. If power is turned off, all label formats and images, as well as any temporarily saved parameter settings stored in the printer's internal memory, are lost. When power is turned back on, these items must be reloaded.

If power is removed from a 600 dpi printer when cleaning the printhead, the **CLEAN HEAD NOW** warning shown on the LCD will not disappear.

If print quality does not improve after you perform this procedure, clean the printhead with *Save-a-Printhead* cleaning film. This specially coated material removes contamination buildup without damaging the printhead. Call an authorized Brady distributor for more information.



Caution • The printhead may be hot and can cause severe burns. Allow the printhead to cool.



Caution • Before touching the printhead assembly, discharge any built-up static electricity by touching the metal printer frame or by using an anti-static wriststrap and mat.

To clean the printhead and platen roller, complete these steps:

1. Open the printhead assembly by rotating the printhead-open lever (1) counter-clockwise.

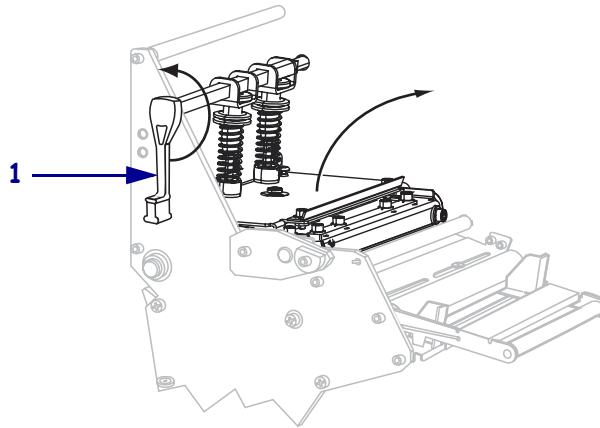

2. Remove the media and ribbon (if loaded).

3. Using the swab from the Preventive Maintenance Kit (part number PCK-4), wipe along the brown strip on the printhead assembly from end to end. In place of the Preventive Maintenance Kit, you may use a clean swab dipped in a solution of isopropyl alcohol (minimum 90%) and deionized water (maximum 10%). Allow the solvent to evaporate.

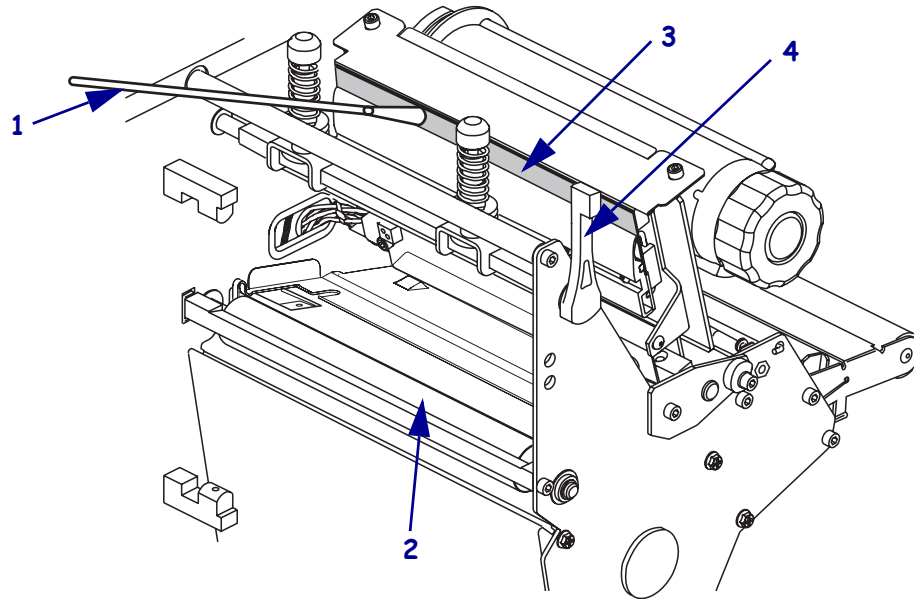

1	Swab
2	Platen roller
3	Printhead print elements
4	Printhead-open lever

4. While manually rotating the platen roller, clean it thoroughly with the swab. Allow the solvent to evaporate.
5. Reload the media and the ribbon (if required).
6. Push down the printhead assembly (1), and then rotate the printhead-open lever (2) clockwise until it locks into place.

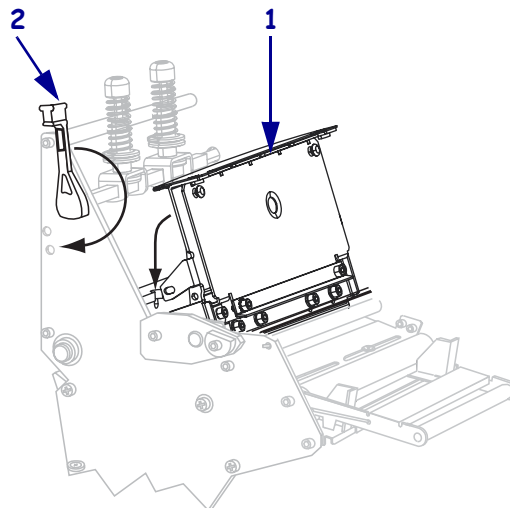

Clean the Sensors

Brush or vacuum any accumulated paper lint and dust off the sensors. Clean the sensors according to the recommendations in [Cleaning Schedule on page 124](#).

Ribbon and Label-Available Sensor Locations

The ribbon sensor and optional label-available sensor are shown in [Figure 32](#).

Figure 32 • Sensor Locations

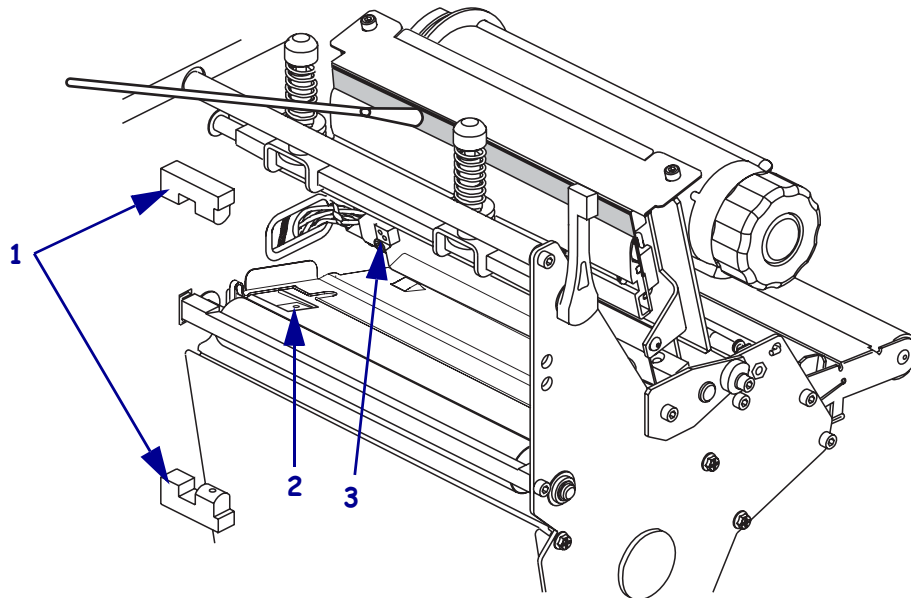

1	Label-available sensors
2	Black mark sensor
3	Ribbon sensor

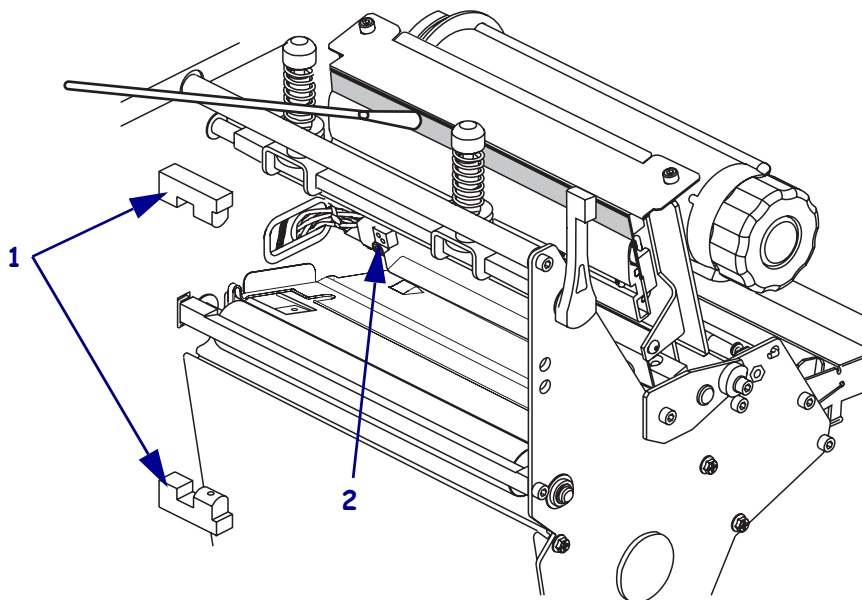

1	Label-available sensors
2	Ribbon sensor

Transmissive (Media) Sensor Locations

The locations of the upper and lower transmissive (media) sensors are shown in [Figure 33](#) and [Figure 34](#).

Figure 33 • Upper Media Sensor

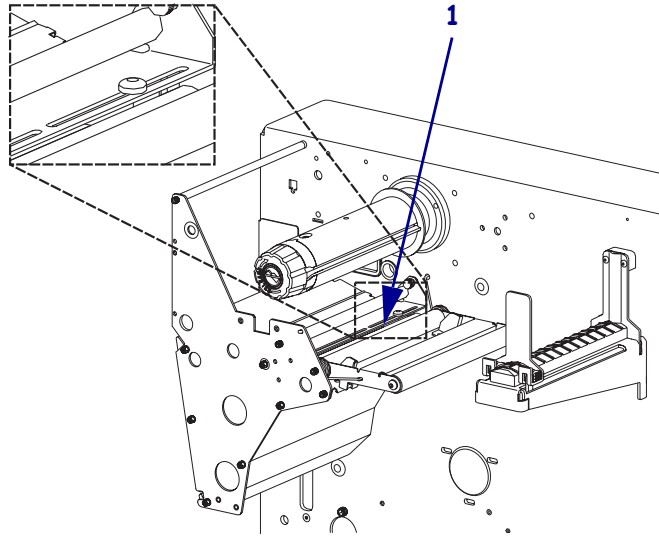

1	Upper media sensor
----------	--------------------

Figure 34 • Lower Media Sensor

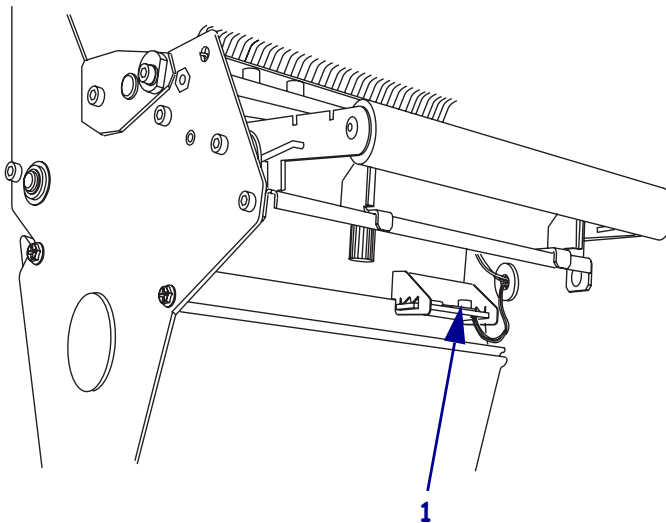

1	Lower media sensor
----------	--------------------

Clean the Snap Plate

Clean the snap plate when label adhesive or a label is stuck to the underside. [Figure 35](#) shows the location of the snap plate.

Figure 35 • Snap Plate

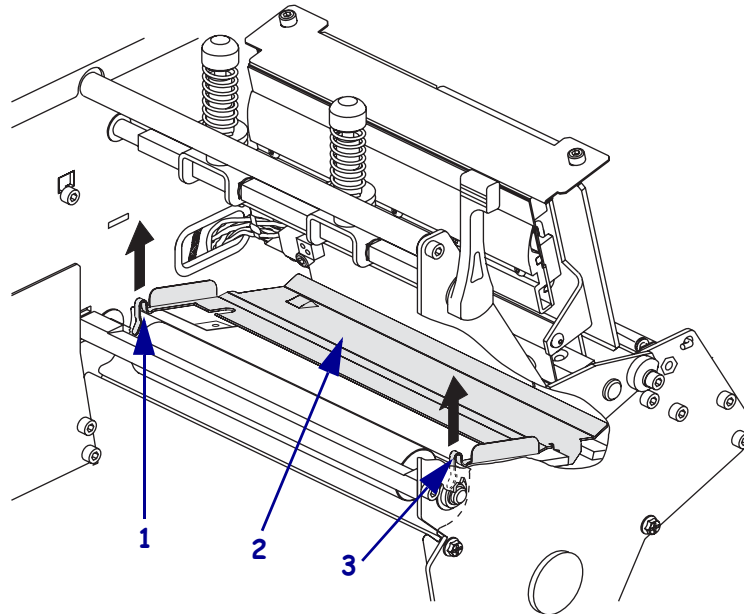

1	Left loop
2	Snap plate
3	Right loop

To clean the snap plate, complete these steps:

1. See [Figure 35](#). Insert a small-blade screwdriver or similar tool into the loop on the left side of the snap plate.



Important • Take care not to bend, twist, or otherwise deform the loops. If the snap plate is damaged in any way, you may need a new plate for proper ribbon sensing.

2. Gently lift the left side of the snap plate.
3. Insert a small-blade screwdriver or similar tool into the loop on the right side of the snap plate.
4. Gently lift the right side of the snap plate.
5. Remove the snap plate from the printer.
6. Clean the snap plate with cleaning solvent and a soft cloth.

7. To reinstall the snap plate, insert the two tabs on the bottom of the snap plate into the two slots of the media path.
8. Slide the snap plate toward you.
9. Press down on the loops to lock the snap plate into place.

Clean the Cutter

If the cutter is not cutting the labels cleanly or if it jams with labels, clean the cutter.



Caution • The cutter blade is sharp. Do not touch or rub the blade with your fingers.

To clean the cutter, complete these steps:

1. Turn off (O) the printer.
2. Unplug the power cord.
3. Clean the stationary cutter blade with a swab and solvent.

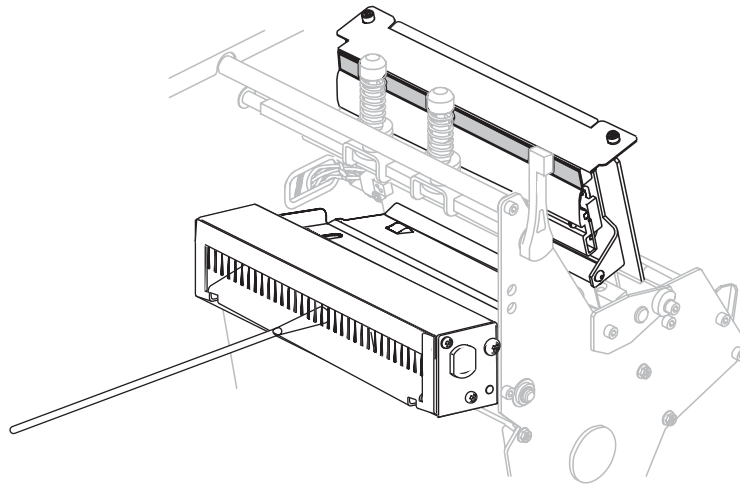

4. If cleaning does not remove label fragments and adhesive, contact an authorized service technician.

Replace the Fuse (360X-Plus II Only)

The instructions that follow are for the 360X-Plus II series printers only. The 300X-Plus II and 600X-Plus II fuses are not user-replaceable.



Caution • Turn the AC power switch off (O) and remove the power cord before performing this procedure.

The printer uses a metric-style fuse (5 × 20 mm IEC) rated at F5A, 250 V. The AC power entry module comes with two approved fuses in the fuse holder: one is in-circuit, and the second is provided as a spare. The end caps of the fuse must bear the certification mark of a known international safety organization (see [Figure 11 on page 25](#)).

To replace a faulty fuse, complete these steps:

1. Use a small-blade screwdriver or similar tool to remove the fuse holder.

The fuse holder is part of the AC power entry module at the rear of the printer ([Figure 36](#)).

Figure 36 • AC Power Entry Module

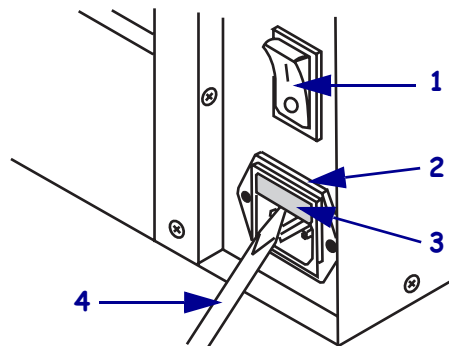

1	Power switch
2	Fuse holder
3	AC power entry module
4	Small-blade screwdriver

2. Remove the faulty fuse and install a new fuse in the in-circuit position ([Figure 37](#)).



Important • If you use the spare fuse, be sure to order a replacement fuse from an authorized Brady distributor. The spare fuse should be the exact type and rating as the original in-circuit fuse.

Figure 37 • Fuse Locations

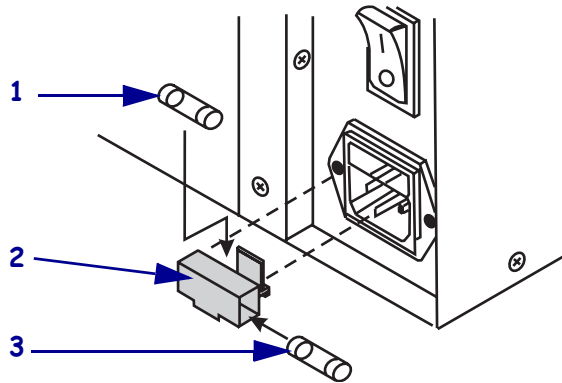

1	In-circuit fuse
2	Fuse holder
3	Spare fuse

3. Snap the fuse holder back into the AC power entry module.
4. Reconnect the power cord, and turn the printer on (I).



Note • If the printer does not power on, an internal component failure may have occurred, and the printer requires servicing by an authorized service technician.



Notes • _____

Troubleshooting

This section provides information about errors that you might need to troubleshoot. Assorted diagnostic tests are included.

Contents

Troubleshooting Checklists	138
LCD Error Messages	139
Print Quality Problems	143
Calibration Problems	146
Communications Problems	147
Ribbon Problems	148
Miscellaneous Printer Problems	149
Printer Diagnostics	151
Power-On Self Test	151
CANCEL Self Test	152
PAUSE Self Test	153
FEED Self Test	154
FEED and PAUSE Self Test	158
Communications Diagnostics Test	159
Sensor Profile	160

Troubleshooting Checklists

If an error condition exists with the printer, review this checklist:

- Is there an error message on the LCD? If yes, see [LCD Error Messages on page 139](#).
- Are noncontinuous labels being treated as continuous labels? If yes, see [Calibrate Media and Ribbon Sensor Sensitivity on page 77](#).
- Is the CHECK RIBBON light on when ribbon is loaded properly, or are noncontinuous labels being treated as continuous labels? If yes, see [Calibrate Media and Ribbon Sensor Sensitivity on page 77](#).
- Are you experiencing problems with print quality? If yes, see [Print Quality Problems on page 143](#).
- Are you experiencing communications problems? If yes, see [Communications Problems on page 147](#).

If the labels are not printing or advancing correctly, review this checklist:

- Are you using the correct type of labels? Review the types of label in [Types of Media on page 26](#).
- Are you using a label that is narrower than the maximum print width? See [Set Print Width on page 67](#).
- Review the label- and ribbon-loading illustrations in [Print Modes on page 34](#) and [Load Ribbon on page 41](#).
- Does the printhead need to be adjusted? See for more information.
- Do the sensors need to be calibrated? See [Calibrate Media and Ribbon Sensor Sensitivity on page 77](#) for more information.

If none of the above suggestions correct the problem, review this checklist:

- Perform one or more of the self-tests given in [Printer Diagnostics on page 151](#). Use the results to help identify the problem.
- If you are still having problems, see [Contacts on page 3](#) for customer support information.

LCD Error Messages

The LCD displays messages when there is an error. See [Table 11](#) for LCD errors, the possible causes, and the recommended solutions.

Table 11 • LCD Error Messages

LCD Display/ Printer Condition	Possible Cause	Recommended Solution
<div style="border: 2px solid black; padding: 5px; text-align: center; width: fit-content; margin: 0 auto;"> ERROR CONDITION RIBBON OUT </div> <p>The printer stops; the RIBBON light is on; the ERROR light flashes.</p>	In thermal transfer mode, ribbon is not loaded or incorrectly loaded.	Load ribbon correctly.
	In thermal transfer mode, the ribbon sensor is not detecting ribbon that is loaded incorrectly.	<ol style="list-style-type: none"> 1. Load ribbon correctly. 2. Calibrate the sensors.
	In thermal transfer mode, media is blocking the ribbon sensor.	<ol style="list-style-type: none"> 1. Load media correctly. 2. Calibrate the sensors.
	In thermal transfer mode, the printer did not detect the ribbon even though it is loaded correctly.	<ol style="list-style-type: none"> 1. Print a sensor profile. See Print Sensor Profile on page 76. The ribbon out threshold (marked by the word RIBBON) is likely too high, above the black area that indicates where the ribbon is detected. <div style="text-align: center; margin: 10px 0;"> </div> 2. Calibrate the sensors or load printer defaults.
If you are using direct thermal media, the printer is waiting for ribbon to be loaded because it is incorrectly set for thermal transfer mode.	Set the printer for Direct Thermal mode. See Select Print Method on page 66 .	

Table 11 • LCD Error Messages (Continued)

LCD Display/ Printer Condition	Possible Cause	Recommended Solution
<div style="border: 1px solid black; padding: 5px; text-align: center;"> WARNING RIBBON IN </div> <p>The RIBBON light is on; the ERROR light flashes.</p>	Ribbon is loaded, but the printer is set for direct thermal mode.	<p>Ribbon is not required with direct thermal media. If you are using direct thermal media, remove ribbon unless you are using it to protect the printhead. This error message will not affect printing.</p> <p>If you are using thermal transfer media, which requires ribbon, set the printer for Thermal Transfer mode. See Select Print Method on page 66.</p>
	Media is not loaded or is loaded incorrectly.	Load media correctly.
<div style="border: 1px solid black; padding: 5px; text-align: center;"> ERROR CONDITION PAPER OUT </div> <p>The printer stops; the MEDIA light is on; the ERROR light flashes.</p>	Misaligned media sensor.	Check position of the media sensor.
	The printer is set for noncontinuous media, but continuous media is loaded.	Install proper media type, or reset printer for current media type and perform calibration.
<div style="border: 1px solid black; padding: 5px; text-align: center;"> ERROR CONDITION HEAD OPEN </div> <p>The printer stops; the ERROR light flashes.</p>	The printhead is not fully closed.	Close printhead completely.
	The head open sensor is not working properly.	Call a service technician.
<div style="border: 1px solid black; padding: 5px; text-align: center;"> WARNING HEAD TOO HOT </div> <p>The printer stops; the ERROR light flashes.</p>	 Caution • The printhead may be hot enough to cause severe burns. Allow the printhead to cool.	
	The printhead is over temperature.	Allow the printer to cool. Printing automatically resumes when the printhead elements cool to an acceptable operating temperature.

Table 11 • LCD Error Messages (Continued)



LCD Display/ Printer Condition	Possible Cause	Recommended Solution
<div style="border: 2px solid black; padding: 5px; text-align: center; width: fit-content; margin: 0 auto;"> WARNING HEAD COLD </div> <p>The printer prints while the ERROR light flashes.</p>	 <p>Caution • An improperly connected printhead data or power cable can cause this error message. The printhead may be hot enough to cause severe burns. Allow the printhead to cool.</p> <p>The printhead temperature is approaching its lower operating limit.</p> <p>The printhead data cable is not properly connected.</p>	<p>Continue printing while the printhead reaches the correct operating temperature. If the error remains, the environment may be too cold for proper printing. Relocate the printer to a warmer area.</p> <p>Caution • Turn off (O) the printer before performing this procedure. Failure to do so can damage the printhead.</p> <ol style="list-style-type: none"> 1. Turn off (O) the printer. 2. Disconnect and reconnect the data cable to the printhead. 3. Ensure that the cable connector is fully inserted into the printhead connector. 4. Turn on (I) the printer.
<div style="border: 2px solid black; padding: 5px; text-align: center; width: fit-content; margin: 0 auto;"> DEFRAGMENTING </div> <p>The printer stops.</p>	<p>The printer is defragmenting memory.</p>	<p>Caution • Do NOT turn off the printer power during defragmenting. Doing so can damage the printer.</p> <p>Allow the printer to finish defragmenting. If you get this error message frequently, check your label formats. Formats that write to and erase memory frequently may cause the printer to defragment often. Using properly coded label formats usually minimizes the need for defragmenting.</p> <p>If this error message does not go away, contact Technical Support. The printer requires service.</p>

Table 11 • LCD Error Messages (Continued)

LCD Display/ Printer Condition	Possible Cause	Recommended Solution
<div style="border: 1px solid black; padding: 5px; text-align: center;"> ERROR CONDITION CUTTER JAM </div> <p>The printer stops; the ERROR light flashes.</p>	 <p>Caution • The cutter blade is sharp. Do not touch or rub the blade with your fingers.</p> <p>Cutter blade is in the media path.</p>	<p>Turn off the print engine power and unplug the printer. Inspect the cutter module for debris and clean as needed following the cleaning instructions in Clean the Cutter on page 133.</p>
<div style="border: 1px solid black; padding: 5px; text-align: center;"> OUT OF MEMORY (function) </div>	<p>There is not enough memory to perform the function specified on the second line of the error message.</p>	<p>Free up some of the printer's memory by adjusting the label format or printer parameters. One way to free up memory is to adjust the print width to the actual width of the label instead of leaving the print width set to the default. See Set Print Width on page 67.</p> <p>Ensure that the device, such as FLASH memory or PCMCIA card, is installed and not write protected or full.</p> <p>Ensure that the data is not directed to a device that is not installed or is unavailable.</p> <p>Call a service technician.</p>

Print Quality Problems

Table 12 identifies problems with print quality, the possible causes, and the recommended solutions.

Table 12 • Print Quality Problems

Problem	Possible Cause	Recommended Solution
General print quality issues	The printer is set at the incorrect print speed.	For optimal print quality, set the print speed to the lowest possible setting for your application via control panel, the driver, or the software. See Adjust Print Speed on page 64 . You may wish to perform the FEED Self Test on page 154 .
	You are using an incorrect combination of labels and ribbon for your application.	<ol style="list-style-type: none"> Switch to a different type of media or ribbon to try to find a compatible combination. If necessary, consult an authorized Brady distributor for information and advice.
	The printer is set at an incorrect darkness level.	For optimal print quality, set the darkness to the lowest possible setting for your application via the control panel, the driver, or the software. See Adjust Print Darkness on page 64 . You may wish to perform the FEED Self Test on page 154 to determine the ideal darkness setting.
	The printhead is dirty.	Clean the printhead. See Clean the Printhead and Platen Roller on page 125 .
Wrinkled ribbon	Ribbon fed through the machine incorrectly.	See Load Ribbon on page 41 .
	Incorrect burn temperature.	Set the darkness to the lowest possible setting for good print quality. See Adjust Print Darkness on page 64 .
	Incorrect or uneven pressure.	Set the pressure to the minimum needed for good print quality. See Adjust Printhead Pressure and Toggle Position on page 53 .
	Media not feeding properly; “walking” from side to side.	Make sure that media is snug by adjusting the media guide, or call a service technician.
	The strip plate needs adjusting.	Call a service technician.
	The printhead needs vertical adjustment.	Call a service technician.
	The printhead and platen roller need to be realigned.	Call a service technician.
Long tracks of missing print on several labels	Print element damaged.	Call a service technician.
	Wrinkled ribbon.	See wrinkled ribbon causes and solutions in this table.
Fine, angular gray lines on blank labels	Wrinkled ribbon.	See wrinkled ribbon causes and solutions in this table.

Table 12 • Print Quality Problems (Continued)

Problem	Possible Cause	Recommended Solution
Printing too light or too dark over the entire label	The media or ribbon is not designed for high-speed operation.	Replace supplies with those recommended for high-speed operation.
	You are using an incorrect combination of media and ribbon for your application.	<ol style="list-style-type: none"> 1. Switch to a different type of media or ribbon to try to find a compatible combination. 2. If necessary, consult an authorized Brady distributor for information and advice.
	You are using ribbon with direct thermal media.	<p>Direct thermal media does not require ribbon. To check if you are using direct thermal media, perform the label scratch test in When to Use Ribbon on page 28.</p> <p>If you are using ribbon intentionally with direct thermal media, increase the darkness level, but note that high darkness levels may decrease printhead life. You may wish to perform the FEED Self Test on page 154 to determine the ideal darkness setting.</p>
	Incorrect or uneven printhead pressure.	Set the pressure to the minimum needed. See Adjust Printhead Pressure and Toggle Position on page 53 .
Smudge marks on labels	The media or ribbon is not designed for high-speed operation.	Replace supplies with those recommended for high-speed operation.
Misregistration/skips labels	The printer is not calibrated.	Recalibrate the printer.
	The media sensor is not positioned correctly.	Perform media sensor position adjustment.
	Improper label format.	Use correct label format.
Misregistration and misprint of one to three labels	The platen roller is dirty.	See Clean the Printhead and Platen Roller on page 125 .
	The media sensor is not positioned correctly.	Place the media sensor in the proper position.
	Media does not meet specifications.	Use media that meets specifications.

Table 12 • Print Quality Problems (Continued)

Problem	Possible Cause	Recommended Solution
Vertical drift in top-of-form position	Normal tolerances of mechanical parts and printer modes.  Note • A vertical drift of ± 4 to 6 dot rows (approximately 0.5 mm) is within normal tolerances.	1. Calibrate the printer. 2. Adjust the label top position setting. See Adjust Label Top Position on page 82 .
	The printer is out of calibration.	Recalibrate the printer.
	The platen roller is dirty.	Clean the platen roller. See Clean the Printhead and Platen Roller on page 125 .
Vertical image or label drift	The printer is using noncontinuous labels but is configured in continuous mode.	Configure the printer for non-continuous and run calibration routine, if necessary.
	The media sensor is positioned incorrectly.	Ensure that the media sensor is properly positioned to read a single/consistent interlabel gap.
	The media sensor is calibrated improperly.	See Calibrate Media and Ribbon Sensor Sensitivity on page 77 .
	The platen roller is dirty.	Clean the platen roller. See Clean the Printhead and Platen Roller on page 125 .
	Improper printhead pressure settings (toggles).	Adjust the printhead pressure to ensure proper functionality.
	Improperly loaded ribbon or media.	Verify that the printer is loaded properly.
	Incompatible media.	Ensure that the interlabel gaps or notches are 2 to 4 mm and consistently placed. Media must not exceed minimum specifications for mode of operation.
The bar code printed on a label does not scan.	The bar code is not within specifications because the print is too light or too dark.	Perform the FEED Self Test on page 154 . Adjust the darkness or print speed settings as necessary.
	Not enough blank space around the bar code.	Leave at least 1/8 in. (3.2 mm) between the bar code and other printed areas on the label and between the bar code and the edge of the label.

Calibration Problems

Table 13 identifies problems with calibration, the possible causes, and the recommended solutions.

Table 13 • Calibration Problems

Problem	Possible Cause	Recommended Solution
Loss of printing registration on labels. Excessive vertical drift in top-of-form registration.	Improperly positioned media guides.	Ensure that the media guides are properly positioned.
	Media type set incorrectly.	Set the printer for the correct media type (non-continuous or continuous). See Set Media Type on page 66 .
	Dirty platen roller.	Clean the platen roller according to the instructions in Clean the Printhead and Platen Roller on page 125 .
Auto Calibrate failed.	Improperly loaded media or ribbon.	Ensure that media and ribbon are loaded correctly.
	The sensors could not detect the media or ribbon.	Manually calibrate the printer. See Calibrate Media and Ribbon Sensor Sensitivity on page 77 .
	The sensors are dirty or positioned improperly.	Ensure that the sensors are clean and properly positioned.

Communications Problems

Table 14 identifies problems with communications, the possible causes, and the recommended solutions.

Table 14 • Communications Problems

Problem	Possible Cause	Recommended Solution
A label format was sent to the printer but was not recognized. The DATA light does not flash.	The communication parameters are incorrect.	Check the printer driver or software communications settings (if applicable).
		If you are using serial communication, check the serial port setting in the control panel menu. See Set Serial Communications on page 78 .
		If you are using serial communication, make sure you are using the correct communication cable. See RS-232 Serial on page 20 for basic cabling information.
		Using the control panel controls, check the protocol setting. It should be set to NONE . See Set Protocol on page 79 .
		If a driver is used, check the driver communication settings for your connection.
A label format was sent to the printer. Several labels print, then the printer skips, misplaces, misses, or distorts the image on the label.	The serial communication settings are incorrect.	Ensure that the flow control settings match.
		Check the communication cable length. See RS-232 Serial on page 20 for requirements.
		Check the printer driver or software communications settings (if applicable).
A label format was sent to the printer but was not recognized. The DATA light flashes but no printing occurs.	The prefix and delimiter characters set in the printer do not match the ones in the label format.	Verify the prefix and delimiter characters. See Set Format Prefix Character on page 80 and Set Delimiter Character on page 81 for the requirements.
	Incorrect data is being sent to the printer.	Check the communication settings on the computer. Ensure that they match the printer settings.
		Ensure that ZPL II is being used.
		If the problem continues, check the ZPL II format for changes to ^CC, ^CT, and ^CD.

Ribbon Problems

Table 15 identifies problems that may occur with ribbon, the possible causes, and the recommended solutions.

Table 15 • Ribbon Problems

Problem	Possible Cause	Recommended Solution
Broken or melted ribbon	Darkness setting too high.	<ol style="list-style-type: none"> 1. Reduce the darkness setting. 2. Clean the printhead thoroughly.
The printer does not detect when the ribbon runs out. In thermal transfer mode, the printer did not detect the ribbon even though it is loaded correctly.	The printer was calibrated without ribbon. Later, ribbon was inserted without the user recalibrating the printer or loading printer defaults.	Calibrate the printer, this time using ribbon, or load printer defaults.
The ribbon light is on even though ribbon is loaded correctly.	The printer was not calibrated for the label and ribbon being used.	Perform the calibration procedure in <i>Calibrate Media and Ribbon Sensor Sensitivity</i> on page 77.

Miscellaneous Printer Problems

Table 16 identifies miscellaneous problems with the printer, the possible causes, and the recommended solutions.

Table 16 • Miscellaneous Printer Problems

Problem	Possible Cause	Recommended Solution
The LCD displays a language that I cannot read	The language parameter was changed through the control panel or a ZPL command.	<ol style="list-style-type: none"> 1. Press SETUP/EXIT to enter configuration mode. 2. Press the left oval. The printer displays the LANGUAGE parameter in the current language. Even if you cannot recognize the characters displayed, you can still scroll to another language. 3. Press the left or right oval to scroll through the choices. 4. Press SETUP/EXIT. The LCD displays SAVE CHANGES in the original language. 5. Press NEXT/SAVE to exit configuration mode and save the changes (if the language does not change, you may need to scroll to a different save option by pressing the left or right oval in the previous step). 6. Repeat this process, if necessary, until you reach the desired language.
The LCD is missing characters or parts of characters	The LCD may need replacing.	Call a service technician.
Changes in parameter settings did not take effect	Parameters are set incorrectly.	<ol style="list-style-type: none"> 1. Set parameters and save permanently. 2. Turn the printer off (O) and then on (I).
	A ZPL command turned off the ability to change the parameter.	Refer to the <i>ZPL Programming Guide</i> , or call a service technician.
	A ZPL command changed the parameter back to the previous setting.	Refer to the <i>ZPL Programming Guide</i> , or call a service technician.
	If the problem continues, there may be a problem with the main logic board.	Call a service technician.

Table 16 • Miscellaneous Printer Problems (Continued)

Problem	Possible Cause	Recommended Solution
The printer fails to calibrate or detect the top of the label.	The printer was not calibrated for the label being used.	Perform the calibration procedure in <i>Calibrate Media and Ribbon Sensor Sensitivity</i> on page 77.
	The printer is configured for continuous media.	Set the media type to noncontinuous media. See <i>Set Media Type</i> on page 66.
	The driver or software configuration is not set correctly.	Driver or software settings produce ZPL commands that can overwrite the printer configuration. Check the driver or software media-related setting.
Non-continuous labels are being treated as continuous labels.	The printer was not calibrated for the media being used.	Perform the calibration procedure in <i>Calibrate Media and Ribbon Sensor Sensitivity</i> on page 77.
	The printer is configured for continuous media.	Set the media type to noncontinuous media. See <i>Set Media Type</i> on page 66.
All lights are on, but nothing displays on the LCD, and the printer locks up.	Internal electronic or firmware failure.	Call a service technician.
The printer locks up while running the Power-On Self Test.	Main logic board failure.	Call a service technician.

Printer Diagnostics

Self tests and other diagnostics provide specific information about the condition of the printer. The self tests produce sample printouts and provide specific information that helps determine the operating conditions for the printer. The most commonly used are the Power-On and the CANCEL self tests.



Important • Use full-width media when performing self tests. If your media is not wide enough, the test labels may print on the platen roller. To prevent this from happening, check the print width using [Set Print Width on page 67](#), and ensure that the width is correct for the media that you are using.

Each self test is enabled by pressing a specific control panel key or combination of keys while turning on (I) the printer power. Keep the key(s) pressed until the first indicator light turns off. The selected self test automatically starts at the end of the Power-On Self Test.



Note •

- When performing these self tests, do not send data to the printer from the host.
- If your media is shorter than the label to be printed, the test label continues on the next label.
- When canceling a self test prior to its actual completion, always reset the printer by turning it off (O) and then on (I).

Power-On Self Test

A Power-On Self Test (POST) is performed each time the printer is turned on (I). During this test, the control panel lights (LEDs) turn on and off to ensure proper operation. At the end of this self test, only the POWER LED remains lit. When the Power-On Self Test is complete, the media is advanced to the proper position.

To initiate the Power-On Self Test, complete these steps:

1. Turn on (I) the printer.

The POWER LED illuminates. The other control panel LEDs and the LCD monitor the progress and indicate the results of the individual tests. All messages during the POST display in English; however, if the test fails, the resulting messages cycle through the international languages as well.

CANCEL Self Test

The CANCEL self test prints a configuration label (Figure 38).

To perform the CANCEL Self Test, complete these steps:

1. Turn off (O) the printer.
2. Press and hold CANCEL while turning on (I) the printer. Hold CANCEL until the first control panel light turns off.
A printer configuration label prints (Figure 38).

Figure 38 • Configuration Label

PRINTER CONFIGURATION	
Brady Corporation	
Bradyprinter X-PLUS II Series	
+11.....	DARKNESS
+000.....	TEAR OFF
TEAR OFF.....	PRINT MODE
CONTINUOUS.....	MEDIA TYPE
WEB.....	SENSOR TYPE
AUTO SELECT.....	SENSOR SELECT
THERMAL-TRANS.....	PRINT METHOD
168 00/12 MM.....	PRINT WIDTH
1219.....	LABEL LENGTH
RS232.....	SERIAL COMM.
38400.....	BAUD
8 BITS.....	DATA BITS
NONE.....	PARITY
XON/XOFF.....	HOST HANDSHAKE
NONE.....	PROTOCOL
000.....	NETWORK ID
NORMAL MODE.....	COMMUNICATIONS
<~> 7EH.....	CONTROL PREFIX
<^> 5EH.....	FORMAT PREFIX
<, > 2CH.....	DELIMITER CHAR
ZPL II.....	ZPL MODE
CALIBRATION.....	MEDIA POWER UP
CALIBRATION.....	HEAD CLOSE
DEFAULT.....	BACKFEED
+000.....	LABEL TOP
+0000.....	LEFT POSITION
058.....	WEB S.
068.....	MEDIA S.
072.....	RIBBON S.
001.....	TAKE LABEL
213.....	MEDIA LED
111.....	RIBBON LED
+10.....	LCD ADJUST
DPSWFXM.....	MODES ENABLED
.....	MODES DISABLED
1984 12/MM FULL....	RESOLUTION
V39.10.5P02 <-.....	FIRMWARE
V1.9.0.0.....	HARDWARE ID
CUSTOMIZED.....	CONFIGURATION
3072.....	R: RAM
NONE.....	B: MEMORY CARD
2048.....	E: ONBOARD FLASH
NONE.....	FORMAT CONVERT
NONE.....	OPTION
PERMANENT.....	IP RESOLUTION
ALL.....	IP PROTOCOL
010.003.004.150....	IP ADDRESS
255.000.000.000....	SUBNET MASK
000.000.000.000....	DEFAULT GATEWAY
2000-12-18 12:18:18	TIME STAMP

FIRMWARE IN THIS PRINTER IS COPYRIGHTED

PAUSE Self Test

This self test can be used to provide the test labels required when making adjustments to the printer's mechanical assemblies or to determine if any printhead elements are not working. Figure 39 shows a sample printout.

To perform a PAUSE self test, complete these steps:

1. Turn off (O) the printer.
2. Press and hold PAUSE while turning on (I) the printer. Hold PAUSE until the first control panel light turns off.
 - The initial self test prints 15 labels at the printer's slowest speed, and then automatically pauses the printer. Each time PAUSE is pressed, an additional 15 labels print. Figure 39 shows a sample of the labels.

Figure 39 • PAUSE Test Label



- While the printer is paused, pressing CANCEL alters the self test. Each time PAUSE is pressed, 15 labels print at 6 in. (152 mm) per second.
- While the printer is paused, pressing CANCEL again alters the self test a second time. Each time PAUSE is pressed, 50 labels print at the printer's slowest speed
- While the printer is paused, pressing CANCEL again alters the self test a third time. Each time PAUSE is pressed, 50 labels print at 6 in. (152 mm) per second.
- While the printer is paused, pressing CANCEL again alters the self test a fourth time. Each time PAUSE is pressed, 15 labels print at the printer's maximum speed.
- To exit this self test at any time, press and hold CANCEL.

FEED Self Test

Different types of media may require different darkness settings. This section contains a simple but effective method for determining the ideal darkness for printing bar codes that are within specifications.

During the FEED self test, labels are printed at different darkness settings at two different print speeds. The relative darkness and the print speed are printed on each label. The bar codes on these labels may be ANSI-graded to check print quality.

The darkness value starts at three settings lower than the printer's current darkness value (relative darkness of -3) and increase until the darkness is three settings higher than the current darkness value (relative darkness of +3).

The speed at which labels are printed during this print quality test depend on the dot density of the printhead.

- 300 dpi printers: 7 labels are printed at the 2 ips and 8 ips print speeds.
- 203 dpi printers: 7 labels are printed at the 2 ips and 12 ips print speeds.

To perform a FEED self test, complete these steps:

1. Print a configuration label to show the printer's current settings.
2. Turn off (O) the printer.
3. Press and hold FEED while turning on (I) the printer. Hold FEED until the first control panel light turns off.

The printer prints a series of labels (Figure 40) at various speeds and at darkness settings higher and lower than the darkness value shown on the configuration label.

Figure 41 • Bar Code Darkness Comparison

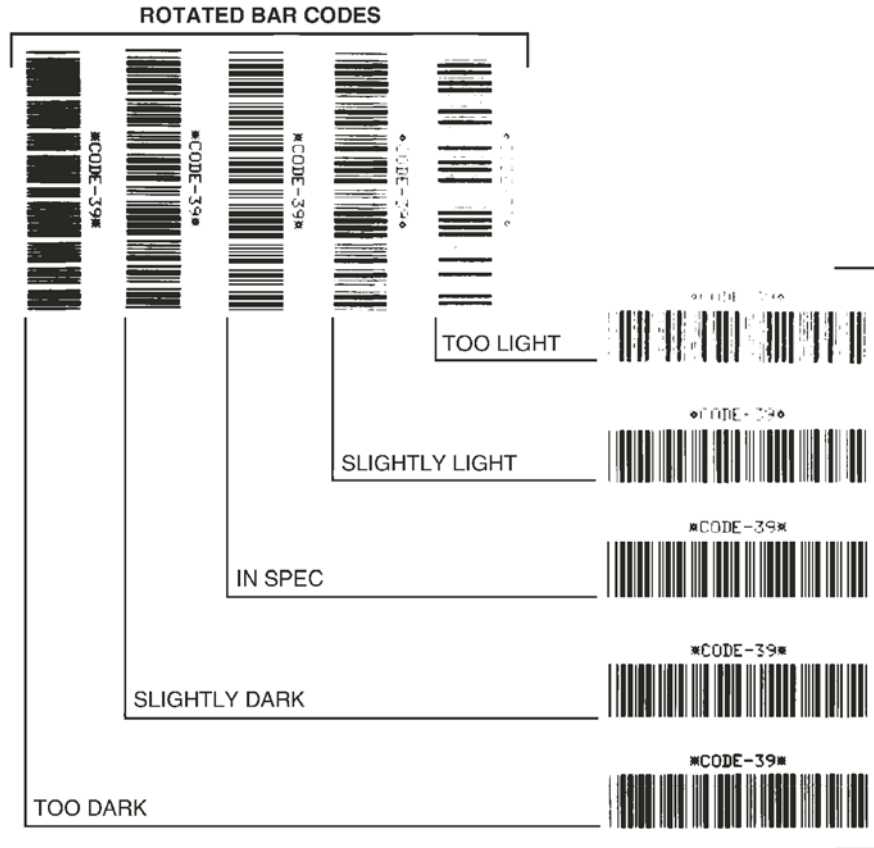

Table 17 • Judging Bar Code Quality

Print Quality	Description
Too dark	<p>Labels that are too dark are fairly obvious. They may be readable but not “in-spec.”</p> <ul style="list-style-type: none"> • The normal bar code bars increase in size. • The openings in small alphanumeric characters may fill in with ink. • Rotated bar code bars and spaces run together.
Slightly dark	<p>Slightly dark labels are not as obvious.</p> <ul style="list-style-type: none"> • The normal bar code will be “in-spec.” • Small character alpha numerics will be bold and could be slightly filled in. • The rotated bar code spaces are small when compared to the “in-spec” code, possibly making the code unreadable.

Table 17 • Judging Bar Code Quality (Continued)

Print Quality	Description
“In-spec”	The “in-spec” bar code can only be confirmed by a verifier, but it should exhibit some visible characteristics. <ul style="list-style-type: none"> • The normal bar code will have complete, even bars and clear, distinct spaces. • The rotated bar code will have complete, even bars and clear, distinct spaces. Although it may not look as good as a slightly dark bar code, the bar code will be “in-spec.” • In both normal and rotated styles, small alphanumeric characters look complete.
Slightly light	Slightly light labels are, in some cases, preferred to slightly dark ones for “in-spec” bar codes. <ul style="list-style-type: none"> • Both normal and rotated bar codes will be in spec, but small alphanumeric characters may not be complete.
Too light	Labels that are too light are obvious. <ul style="list-style-type: none"> • Both normal and rotated bar codes have incomplete bars and spaces. • Small alphanumeric characters are unreadable.

5. Note the relative darkness value and the print speed printed on the best test label.
6. Add or subtract the relative darkness value from the darkness value specified on the configuration label. The resulting numeric value (0 to 30) is the best darkness value for that specific label/ribbon combination and print speed.
7. If necessary, change the darkness value to the darkness value on the best test label. See [Adjust Print Darkness on page 64](#).
8. If necessary, change the print speed to the same speed as on the best test label. See [Adjust Print Speed on page 64](#).

FEED and PAUSE Self Test

Performing this self test temporarily resets the printer configuration to the factory default values. These values are active only until power is turned off unless you save them permanently in memory. If the factory default values are permanently saved, a media calibration procedure must be performed, and you must reset the head resistance value and the verifier and applicator port settings to their required values.

To perform a FEED and PAUSE self test, complete these steps:

1. Turn off (O) the printer.
2. Press and hold FEED and PAUSE while turning on (I) the printer.
3. Hold FEED and PAUSE until the first control panel light turns off.

The printer configuration is temporarily reset to the factory default values. No labels print at the end of this test.

Communications Diagnostics Test

The communication diagnostics test is a troubleshooting tool for checking the interconnection between the printer and the host computer.

When the printer is in diagnostics mode, it prints all data received from the host computer as straight ASCII characters with the hex values below the ASCII text. The printer prints all characters received, including control codes such as CR (carriage return). [Figure 42](#) shows a typical test label from this test.



Note • The test label prints upside-down.

Figure 42 • Communications Diagnostics Test Label



To use communications diagnostics mode, complete these steps:

1. Set the print width equal to or less than the label width being used for the test. See [Set Print Width on page 67](#) for more information.
2. Set the printer to **DIAGNOSTICS**. For instructions, see [Set Communications Mode on page 80](#).

The printer enters diagnostics mode and prints any data received from the host computer on a test label

3. Check the test label for error codes. For any errors, check that your communication parameters are correct.

Errors show on the test label as follows:

- FE indicates a framing error.
- OE indicates an overrun error.
- PE indicates a parity error.
- NE indicates noise.

4. Turn the printer off (**O**) and then back on (**I**) to exit this self test and return to normal operation.

Sensor Profile

Use the sensor profile label to troubleshoot the following types of problems:

- If the media sensor experiences difficulty in determining gaps (web) between labels.
- If the media sensor incorrectly identifies preprinted areas on a label as gaps (web).

For instructions on printing a sensor profile, see [Print Sensor Profile on page 76](#). If the sensitivity of the sensors must be adjusted, perform [Calibrate Media and Ribbon Sensor Sensitivity on page 77](#).

The media sensor readings are shown as bars and flat areas on the sensor profile. The bars (1) indicate gaps between labels (the web), and the low areas (2) indicate where labels are located. If you compare the sensor profile printout to a blank length of your media, the bars should be the same distance apart as the gaps on the media. If the distances are not the same, the printer may be having difficulty determining where the gaps are located.

The media sensor threshold settings are shown by the words MEDIA (3) for the media threshold and WEB (4) for the web threshold. Use the numbers to the left of the sensor readings to compare the numeric readings to the sensor settings.

Figure 43 • Sensor Profile (Media Section)

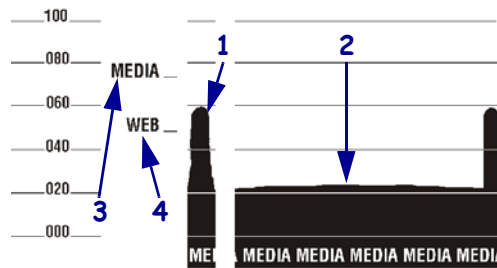

Data Ports

This section describes the standard communication ports available to connect the printer to your computer or network.

Contents

Parallel Data Port	162
Parallel Cabling Requirements	162
Parallel Port Interconnections	162
Serial Data Port	164
Hardware Control Signal Descriptions	164
Pin Configuration	165
RS-232 Interface Connections	166
Applicator Interface Connector	168
Applicator Signals	168
Applicator Interface Connector Pin Configuration	170
Jumper Configurations and Pinouts for +5 V I/O Operation	173
Pinouts for +24-28 V I/O Operation	174

Parallel Data Port

The parallel data interface supports IEEE 1284 bidirectional parallel communications in nibble mode. The parallel interface provides a means of communication that typically is faster than the serial interface methods. In this method, the bits of data that make up a character are sent all at one time over several wires in the cable, one bit per wire.

When communicating via the parallel port, the values selected on the printer must be the same as those used by the host equipment connected to the printer. Port selection for status information is determined by the channel sending the request. The parallel port can be set for bidirectional or unidirectional communication. The default setting is bidirectional.

Parallel Cabling Requirements

See [IEEE 1284 Bidirectional Parallel on page 21](#) for basic cabling information.

A standard 36-pin parallel connector is available on the back of the printer for connection to the data source. An IEEE-1284 compatible bidirectional parallel data cable is required when this communication method is used. The required cable must have a standard 36-pin parallel connector on one end that is plugged into the mating connector located at the rear of the printer. The other end of the cable connects to the printer connector at the host computer. Port selection for status information is determined each time the printer is turned on.

Parallel Port Interconnections

[Table 18](#) shows the pin configuration and function of a standard computer-to-printer parallel cable.

Table 18 • Parallel Cable Pin Configuration

36-Pin Connectors	Description
1	nStrobe/HostClk
2–9	Data Bits 1–8
10	nACK/PtrClk
11	Busy/PtrBusy
12	PError/ACKDataReq
13	Select/Xflag
14	nAutoFd/HostBusy
15	Not used
16, 17	Ground
18	+5 V at 750 mA The maximum current draw may be limited by option configuration.
19–30	Ground

Table 18 • Parallel Cable Pin Configuration (Continued)

36-Pin Connectors	Description
31	nInit
32	nFault/NDataAvail
33, 34	Not used
35	+5 V through a 1.8 K Ω Resistor
36	NSelectin/1284 active

Serial Data Port

See *RS-232 Serial* on page 20 for basic cabling information.

To communicate using the serial data port of the printer, you must choose the number of data bits, parity, and handshaking. Parity applies only to data transmitted by the printer because the parity of received data is ignored.

The values selected must be the same as those used by the host equipment connected to the printer. Default printer settings are 9600 baud, 8 data bits, no parity, and XON/XOFF. The printer will accept any host setting for stop bits.

Hardware Control Signal Descriptions

For all RS-232 input and output signals, the printer follows both the Electronics Industries Association (EIA) RS-232 and the Consultative Committee for International Telegraph and Telephone (CCITT) V.24 standard signal level specifications.

When DTR/DSR handshaking is selected, the Data Terminal Ready (DTR) control signal output from the printer controls when the host computer may send data. DTR ACTIVE (positive voltage) permits the host to send data. When the printer places DTR in the INACTIVE (negative voltage) state, the host must not send data.



Note • When XON/XOFF handshaking is selected, data flow is controlled by the ASCII Control Codes DC1 (XON) and DC3 (XOFF). The DTR Control lead has no effect.

Request To Send (RTS) is a control signal from the printer that is connected to the Clear To Send (CTS) input at the host computer.

Pin Configuration

Connect the serial data cable to the female DB-9 connector on the back of the printer. For all RS-232 connections through a DB-25 cable, use a DB-9 to DB-25 interface module (see [DB-9 to DB-25 Connections](#) on page 167).

Table 19 shows the pin configuration of the serial data connector.

Table 19 • Serial Connector Pin Configuration

Pin No.	Name	Description
1	+5 VDC	Connected to Pin 9
2	RXD	Receive data—data input to printer
3	TXD	Transmit data—data output from printer
4	DTR	Data terminal ready—output from printer
5	SG	Signal ground
6	DSR	Data set ready—input to printer
7	RTS	Request to send—output from printer
8	CTS	Clear to send—input to printer
9	+5 VDC	+5 VDC at 750 mA (connected to Pin 1) The maximum current draw may be limited by option configuration.

RS-232 Interface Connections

The printer is configured as Data Terminal Equipment (DTE). Figure 44 shows the internal connections of the printer's RS-232 connector.



Note • Use a null modem (crossover) cable to connect the printer to a computer or any other DTE device.

Figure 44 • RS-232 DB9 MLB Connections

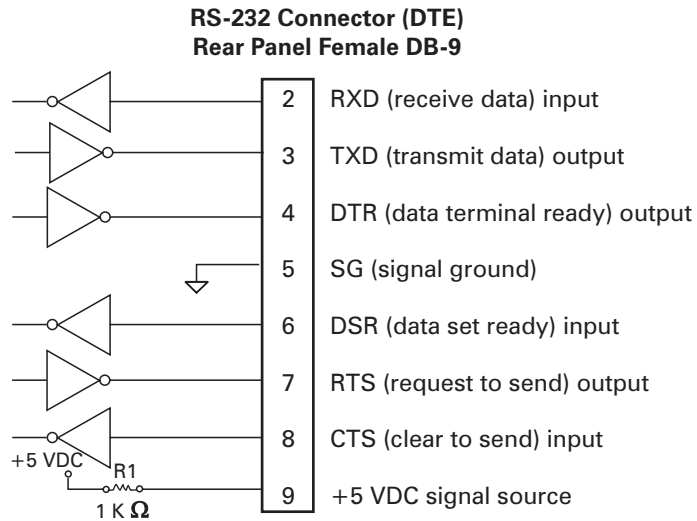

NOTE: Pin 1 is unused and unterminated.

Pin 9 is also available as a +5 VDC signal source at 750 mA. The maximum current draw may be limited by option configuration.



Important • To enable this capability, a qualified service technician must install a jumper on the printer's main logic board on JP1, pins 2 and 3.

DB-9 to DB-25 Connections

To connect the printer's RS-232 DB-9 interface to a DB-25 connector, an interface adapter is required. A generic DB-25 adapter can be used, although the +5 VDC signal source would not be passed through the adapter. [Figure 45](#) shows the connections required for the DB-9 to DB-25 interface.

Figure 45 • DB-9 to DB-25 Cable Connections

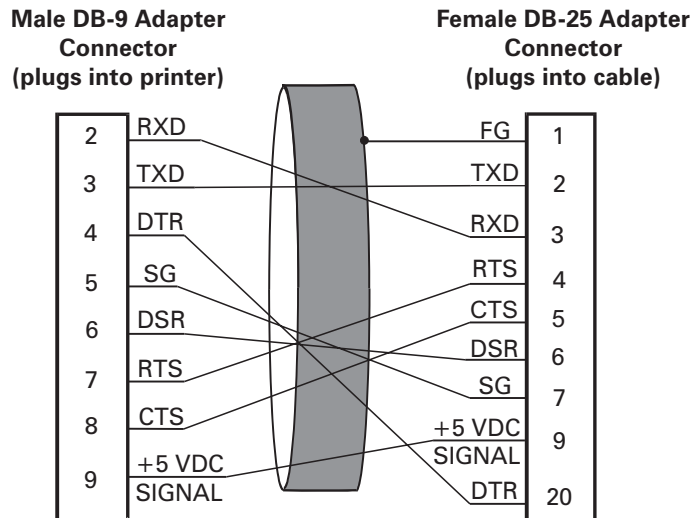

NOTE: Pin 1 of DB-9 connector is unused and unterminated.

Modem Connection

When the printer is connected via its RS-232 interface to Data Communication Equipment (DCE) such as a modem, use a standard RS-232 (straight-through) interface cable. [Figure 46](#) shows the connections required for this cable.

Figure 46 • RS-232 Cable Connections

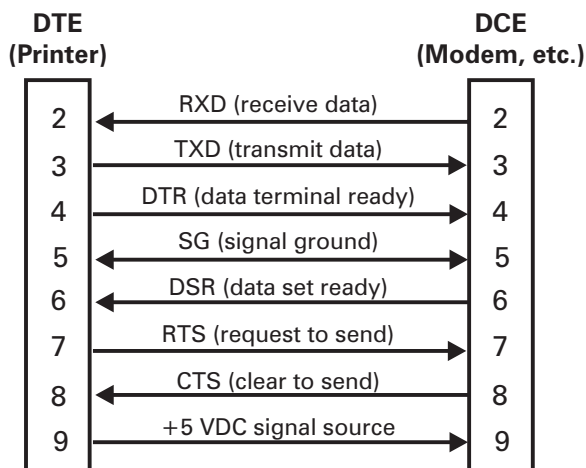

NOTE: Pin 1 is unused and unterminated at the printer.

Applicator Interface Connector

An external DB-15 connector is present on the rear panel of the printer for communication with a customer applicator. An optional DB-15 to DB-9 adapter cable is available to accommodate existing DB-9 interfaces.

Applicator Signals

The printer communicates with a customer applicator through a series of signals on the pins in the DB-15 connector. Each pin causes different things to happen when the signal is active (asserted) or not active (deasserted). [Applicator Interface Connector Pin Configuration](#) on page 170 provides additional information about each pin and signal.

Figure 47 • Applicator Signals (Mode 1)

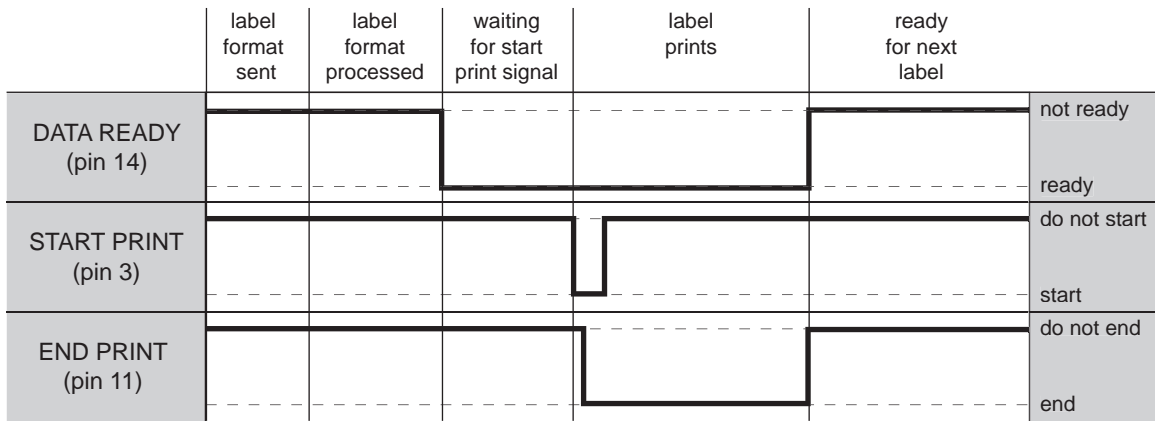

Figure 48 • Applicator Signals (Mode 2)

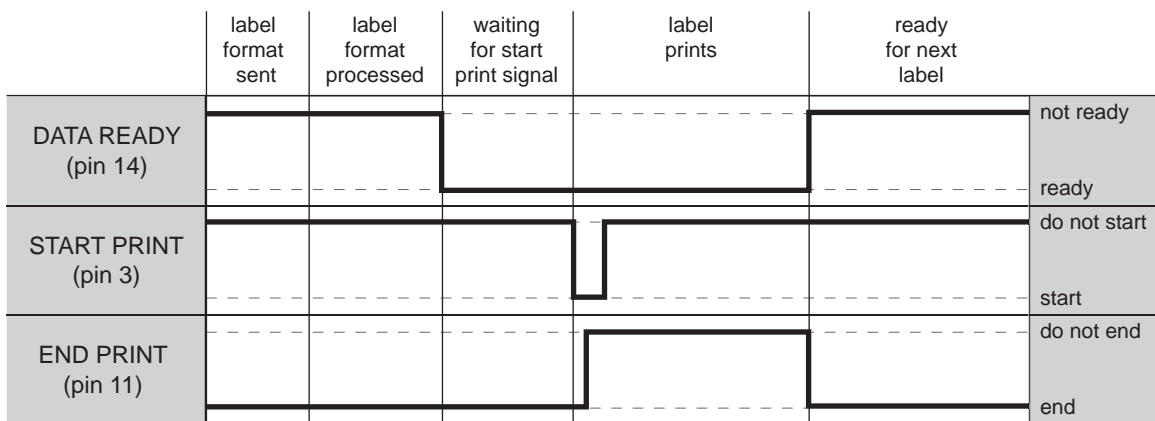

Figure 49 • Applicator Signals (Mode 3)

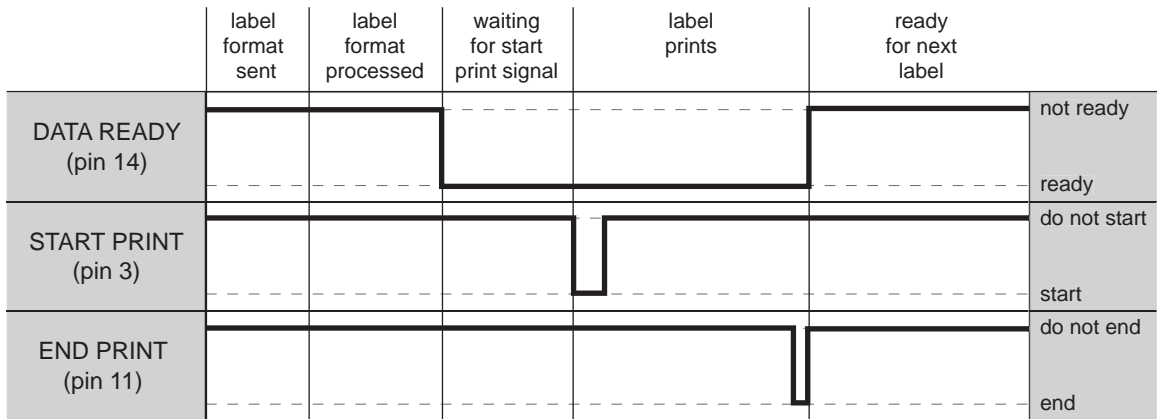
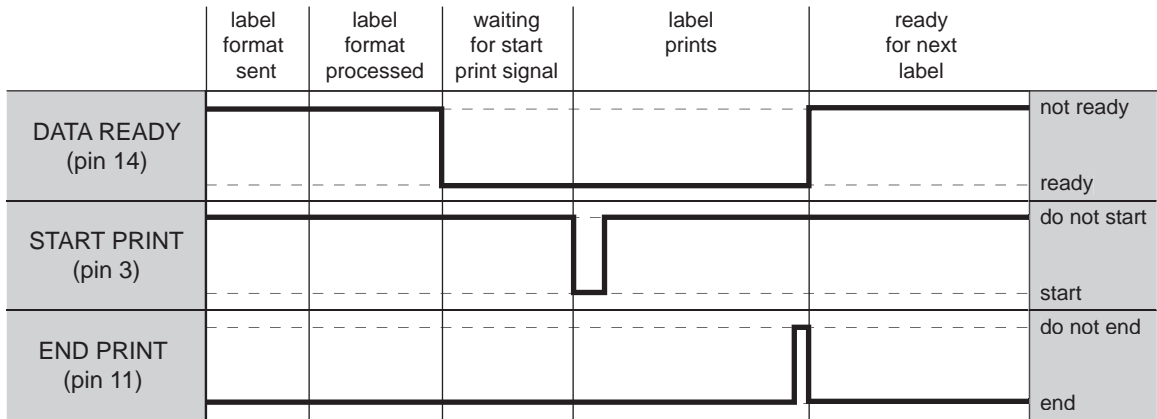

Figure 50 • Applicator Signals (Mode 4)



Applicator Interface Connector Pin Configuration

The Applicator Interface Assembly is available in two versions: a +5 V I/O and a +24–28 V I/O. [Table 20](#) lists the pin configurations and functions of the applicator interface connector for both +5 V and +24–28 V operation.

Table 20 • Applicator Interface Connector Pin Configuration



Pin No.	Signal Name	Signal Type	Description
1	I/O SIGNAL GROUND (+5V Return)	I/O Signal Ground	Using jumper J5, this pin can be configured as isolated or non-isolated from the printer signal ground. See Jumper Configurations and Pinouts for +5 V I/O Operation on page 173 for more information.
1	I/O SIGNAL GROUND (+24-28V Return)	I/O Signal Ground	No jumpers to configure.  Important • Customer must provide this external ground (can come from pin 8). See Pinouts for +24-28 V I/O Operation on page 174 for more information.
2	+5V I/O (Fused at 1 A) Caution • Replace the fuse only with one of the same type and rating.	Power	Using jumper J4, this pin can be configured as isolated or non-isolated from the Applicator Interface Circuit +5 V Supply. See Jumper Configurations and Pinouts for +5 V I/O Operation on page 173 for more information.
2	+24-28V I/O	Power	No jumpers to configure. This +24-28V power source also supplies voltage for output signal pull-up resistors.  Important • Customer must provide this external power (can come from pin 7). See Pinouts for +24-28 V I/O Operation on page 174 for more information.
3	START PRINT	Input	<ul style="list-style-type: none"> • Pulse Mode—The label printing process begins on the HIGH to LOW transition of this signal if a format is ready. Deassert this signal HIGH to inhibit printing of a new label. • Level Mode—Assert LOW to enable the printer to print if a label format is ready. When deasserted HIGH, the printer completes the label that is printing then stops and waits for this input to be reasserted LOW.
4	FEED	Input	When the printer is idle or has been paused, assert this input LOW to trigger repeated feeding of blank labels. Deassert HIGH to stop feeding blank labels and register to the top of the next label.
5	PAUSE	Input	To toggle the current Pause state, this input must be asserted LOW for 200 milliseconds, or until the SERVICE REQUIRED output (pin 10) changes state.

Table 20 • Applicator Interface Connector Pin Configuration (Continued)



Pin No.	Signal Name	Signal Type	Description
6	REPRINT	Input	<ul style="list-style-type: none"> • If the Reprint feature is enabled, this input must be asserted LOW to cause the printer to reprint the last label. • If the Reprint feature is disabled, this input is ignored.
7	+28 V (Fused at 500 mA.) Caution • Replace the fuse only with one of the same type and rating.	Power	<p>The Interface Power Supply. Supplies power to external sensors as required.</p>  Note • If operating with 28V signals only, pin 7 may be used to supply power to pin 2, which creates a non-isolated mode of operation.
8	POWER GROUND (+28 V DC Return)	Ground	<p>The Interface Power Ground.</p>  Note • If pin 7 is used to supply power to pin 2, use this pin to ground pin 1.
9			
10	SERVICE REQUIRED	Output	<p>Asserted LOW in the following circumstances:</p> <ul style="list-style-type: none"> • the media cover is open • the printhead is open • the ribbon or media is out • the printer is paused • an operational fault occurs • a Resynch error occurs while the applicator Resynch mode is set to Error mode
11	END PRINT	Output	<ul style="list-style-type: none"> • MODE 0—The applicator port is OFF. • MODE 1—Asserted LOW only while the printer is moving the label forward; otherwise deasserted HIGH. • MODE 2—Asserted HIGH only while the printer is moving the label forward; otherwise deasserted LOW. • MODE 3—(Default) Asserted LOW for 20 milliseconds when a label is completed and positioned. Not asserted during continuous printing. • MODE 4—Asserted HIGH for 20 milliseconds when a label is completed and positioned. Not asserted during continuous printing.
12	MEDIA OUT	Output	Asserted LOW while there is no media in the printer.

Table 20 • Applicator Interface Connector Pin Configuration (Continued)

Pin No.	Signal Name	Signal Type	Description
13	RIBBON OUT	Output	Asserted LOW while there is no ribbon in the printer.
14	DATA READY	Output	See Applicator Signals on page 168 for more information about this signal. <ul style="list-style-type: none">• Asserted LOW when sufficient data has been received to begin printing the next label.• Deasserted HIGH whenever printing stops after the current label, due to either a pause condition or the absence of a label format.

Jumper Configurations and Pinouts for +5 V I/O Operation

Jumpers J4 and J5 are used together to produce isolated or non-isolated modes of operation for applicator input and output control signals. J4 configures the +5 V source for the optoisolator circuits, and J5 configures the ground. For proper operation, when J4 is installed, J5 must be installed, and when J4 is removed, J5 must be removed.

Table 21 describes the pin and jumper configurations for +5 V I/O operation.

Table 21 • Non-Isolated and Isolated Modes for +5V Operation

	Non-Isolated (Jumpers In)	Isolated (Jumpers Out)
Pin 1	Ground +5V, Jumper J5 In I/O ground is connected to the printer signal ground.	External Ground +5V, Jumper J5 Out I/O ground is disconnected from the printer signal ground. Ground must be provided externally to this pin.
Pin 2	+5V Output, Jumper J4 In +5 V I/O is connected to the applicator interface circuit +5 V Supply.	External +5V Input, Jumper J4 Out +5 V I/O is disconnected from the applicator interface circuit +5 V Supply. The +5 V for the applicator interface optoisolator circuits must be provided externally. This input also supplies voltage for output signal pull-up resistors.
Pinouts		

Pinouts for +24-28 V I/O Operation

Table 22 describes the pin configurations for +24–28 V I/O operation. There are no jumpers to configure for this mode.

Table 22 • Non-Isolated and Isolated Modes for +24–28V Operation

	Isolated (External Power)	Non-Isolated (Internal Printer Power)
Pin 1	External Ground +24-28V I/O ground must be connected to an external ground.	Ground +28V from Pin 8 If pin 7 is used to supply power to pin 2, use pin 8 to ground pin 1.
Pin 2	+24-28V External Input +24-28 V I/O must be connected to an external power supply. This input also supplies voltage for output signal pull-up resistors.	+28V Input from Pin 7 If operating with 28V signals only, pin 7 may be shorted to pin 2, which creates a non-isolated mode of operation. This input also supplies voltage for output signal pull-up resistors.
Pinouts		

Specifications

This section provides the features of and specifications for this printer.

Contents

Features	176
Standard Features	176
Print Modes	176
Zebra Programming Language (ZPL)	176
Bar Codes	177
Agency Approvals	178
General Specifications	179
Physical Specifications	179
Electrical Specifications	179
Environmental Conditions for Operation and Storage	179
Print Specifications by Model	180
Ribbon Specifications	181
Media Specifications	182
BP-300X-Plus II and 600 X-Plus II Printers	182
BP-300X-Plus II and 600 X-Plus II Printers	182

Features

This section lists the standard and optional features for the printer.

Standard Features



Note • Printer specifications are subject to change without notice.

- Thermal transfer and direct thermal printing
- DRAM 16 MB
- USB 2.0 Port
- Real-time Clock
- Advanced Counter

Print Modes

Five different print modes can be used, depending on the printer options purchased:

- **Tear-Off Mode:** Labels are produced in strips.
- **Peel-Off Mode:** Labels are dispensed and peeled from the backing as needed.
- **Cutter Mode:** Labels are printed and individually cut.
- **Applicator Mode:** The printer is part of a larger label application system.
- **Rewind Mode:** Labels are rewound internally.

Zebra Programming Language (ZPL)

ZPL II features include:

- Downloadable graphics, scalable and bitmap fonts, and label formats
- Object copying between memory areas
- (RAM, memory card, and internal Flash)
- Code page 850 character set
- Data compression
- Automatic virtual input buffer management
- Format inversion
- Mirror image printing
- Four-position field rotation (0°, 90°, 180°, 270°)
- Slew command
- Controlled via mainframe, mini-computer, PC, portable data terminal
- Programmable quantity with print, pause, and cut control
- Communicates in printable ASCII characters
- Error-checking protocol
- Status message to host upon request
- Serialized fields
- In-spec OCR-A and OCR-B
- UPC/EAN
- User-programmable password

Bar Codes

Types of bar codes include:

- Bar code ratios—2:1, 7:3, 5:2, 3:1
- Codabar (supports ratios of 2:1 up to 3:1)
- CODABLOCK
- Code 11
- Code 39 (supports ratios of 2:1 up to 3:1)
- Code 49 (two-dimensional bar code)
- Code 93
- Code 128 (with subsets A, B, and C and UCC case codes)
- Check digit calculation where applicable
- Data Matrix
- EAN-8, EAN-13, EAN extensions
- ISBT-128
- Industrial 2 of 5
- Interleaved 2 of 5 (supports ratios of 2:1 up to 3:1, Modulus 10 Check Digit)
- LOGMARS
- MaxiCode
- Micro PDF
- MSI
- PDF-417 (2-dimensional bar code)
- PLANET code
- Plessey
- POSTNET
- QR-Code
- RSS code
- Standard 2 of 5
- TLC 39
- UPC-A, UPC-E, UPC extensions

Agency Approvals

Agency Approvals	<ul style="list-style-type: none">• IEC 60950-1• EN55022, Class B• EN55024• EN61000-3-2, -3-3
Product Markings	<ul style="list-style-type: none">• cULus• CE• FCC - B• ICES-003• VCCI• C-Tick• CCC• NOM• Gost-R• S Mark (Argentina)• MIC• BSMI• ZIK

General Specifications

Physical Specifications

Dimensions	BP-300/600X-Plus II	BP-360X-Plus II
Height	15.5 in. (393.7 mm)	15.5 in. (393.7 mm)
Width	10.37 in. (263.5 mm)	13.15 in. (334.4 mm)
Depth	19.5 in. (495.3 mm)	19.5 in. (495.3 mm)
Weight without options	51 lb. (25 kg)	67 lb. (30.5 kg)

Electrical Specifications

Power	BP-300/600X-Plus II	BP-360X-Plus II
General	90 to 264 VAC; 48 to 62 Hz	90 to 264 VAC; 48 to 62 Hz
Power consumption printing PAUSE test at slowest speed	180 W	220 W
Printer idle	20 W	20 W





Environmental Conditions for Operation and Storage













Environment	Mode	Temperature	Relative Humidity
Operation	Thermal Transfer	41° to 104°F (5° to 40° C)	20 to 85% non-condensing
	Direct Thermal	32° to 104°F (0° to 40° C)	
Storage	Thermal Transfer or Direct Thermal	-40° to 140°F (-40° to 60° C)	5 to 85% non-condensing

Print Specifications by Model

Refer to the key and the table that follows for printer specifications.

Specifications Key

	Non-Continuous printing (gap, notch, or hole between labels).
	Continuous printing (no gap, notch or hole).
	Ladder (rotated) orientation.
	Picket fence (nonrotated) orientation.

Print Specifications	BP-300X-Plus II	BP-600X-Plus II	BP-360X-Plus II
Printhead resolution	300 dots/inch (12 dots/mm)	600 dots/inch (24 dots/mm)	300 dots/inch (12 dots/mm)
Dot size (width×length)	0.0033×0.0033 in. (0.84×0.084 mm)	0.0016×0.0016 in. (0.042×0.042 mm)	0.0033×0.0033 in. (0.84×0.084 mm)
First dot location (measured from inside media edge)	0.023 ± 0.035 in. (0.6 ± 0.9 mm)	0.023 ± 0.035 in. (0.6 ± 0.9 mm)	0.10 ± 0.035 in. (2.5 ± 0.89 mm)
Maximum print width	4.09 in. (104 mm)	3.2 in. (81 mm)	6.6 in. (168 mm)
Selectable print speeds (inches per second)	2.4, 3 through 8	1.5, 2 through 4	2.4, 3, 4, 5, 6, 7, 8
Maximum Print length	39 in. (991 mm)  100 in. (3810 mm) 	39 in. (991 mm)  39 in. (991 mm) 	39 in. (991 mm)  100 in. (3810 mm) 
Bar code modulus (X) dimension	3.9 mil to 39 mil  3.33 mil to 33 mil 	1.6 mil to 16 mil  1.6 mil to 16 mil 	3.9 mil to 39 mil  3.33 mil to 33 mil 
Thin film printhead with Element Energy Equalizer (E ³) [®]	Yes	Yes	Yes

Ribbon Specifications

Refer to the following table for ribbon specifications.



Note • Consider the following when using ribbon:

- Match the ribbon to the label width and printhead width that you are using. The ribbon should be at least as wide as the labels to protect the printhead from excessive wear.
- Ribbon must be wound with the coated side out.

Ribbon Specifications	BP-300X-Plus II	BP-600X-Plus II	BP-360X-Plus II
Printhead resolution	300 dots/inch (12 dots/mm)	600 dots/inch (24 dots/mm)	300 dots/inch (12 dots/mm)
Ribbon width Minimum	0.79 in. (20 mm)	0.79 in. (20 mm)	2.0 in. (51 mm)
Ribbon width Maximum	4.33 in. (110 mm)	3.40 in. (87 mm)	6.7 in. (170 mm)
Standard length with 2:1 label to ribbon ratio	984 ft (300 m)	984 ft (300 m)	984 ft (300 m)
Standard length with 3:1 label to ribbon ratio	1476 ft (450 m)	1476 ft (450 m)	1476 ft (450 m)
Ribbon core inside diameter	1.0 in. (25.4 mm)	1.0 in. (25.4 mm)	1.0 in. (25.4 mm)
Maximum ribbon roll outside diameter	3.2 in. (81.3 mm)	3.2 in. (81.3 mm)	3.2 in. (81.3 mm)

Media Specifications

Use the correct size and type of labels for best performance. Refer to the tables that follow for specifications.



Important • Media registration and minimum label length are affected by label type and width, ribbon type, print speed, and printer mode of operation. Performance improves as these factors are optimized. Brady recommends qualifying any application with thorough testing.

BP-300X-Plus II and 600 X-Plus II Printers

Media Specifications		BP-300X-Plus II	BP-600X-Plus II
Minimum label length	Tear-Off	0.7 in. (18 mm)	0.7 in. (18 mm)
	Peel-Off	0.5 in. (13 mm)	0.5 in. (13 mm)
	Cutter	1.5 in. (38 mm)	1.5 in. (38 mm)
	Rewind	0.25 in. (6 mm)	0.25 in. (6 mm)
Total media width (label + backing, if any)	Minimum	0.79 in. (20 mm)	0.79 in. (20 mm)
	Maximum	4.5 in. (114 mm)	4.5 in. (114 mm)
Total thickness (includes backing, if any)	Minimum	0.003 in. (0.076 mm)	0.003 in. (0.076 mm)
	Maximum	0.012 in. (0.305 mm)	0.012 in. (0.305 mm)
Cutter maximum full-width media thickness		0.009 in. (0.23 mm)	Does not apply
Roll media core inside diameter		3 in. (76 mm)	3 in. (76 mm)
Maximum roll diameter on 3 in. (76 mm) core		8.0 in. (203 mm)	8.0 in. (203 mm)
Interlabel gap	Minimum	0.079 in. (2 mm)	0.079 in. (2 mm)
	Preferred	0.118 in. (3 mm)	0.118 in. (3 mm)
	Maximum	No more than the calibrated length of the label.	No more than the calibrated length of the label.
Maximum internal fanfold media pack size (label + backing) L × W×H		8.0×5.5×4.5 in. (203×40×114 mm)	8.0×7.1×4.5 in. (203×180×114 mm)
Ticket/tag sensing notch L × W		0.12×0.25 in. (3×6 mm)	0.12×0.25 in. (3×6 mm)
Ticket/tag sensing hole diameter		0.125 in. (3 mm)	0.125 in. (3 mm)
Label registration tolerance (vertical)		± 0.06 in. (± 1.5 mm)	± 0.06 in. (± 1.5 mm)
Label registration tolerance (horizontal)		± 0.06 in. (± 1.5 mm)	± 0.06 in. (± 1.5 mm)

BP-300X-Plus II and 600X-Plus II Black Mark Sensing Only

Media Specifications		BP-300X-Plus II	BP-600X-Plus II
Mark length (measuring parallel to label/tag edge)	Minimum	0.12 in. (3 mm)	0.12 in. (3 mm)
	Maximum	0.43 in. (11 mm)	0.43 in. (11 mm)
Mark width (measuring to perpendicular label/tag edge)	Minimum	0.43 in. (11 mm)	0.43 in. (11 mm)
	Maximum	Full media width	Full media width
Mark location		within 0.040 in. (1 mm) of the inside media edge	within 0.040 in. (1 mm) of the inside media edge
Mark density in Optical Density Unit (ODU)		>1.0	>1.0

BP-360X-Plus II Printers

Media Specifications	BP-360X-Plus II	
Minimum label length	Tear-Off	0.7 in. (18 mm)
	Peel-Off	0.5 in. (13 mm)
	Cutter	1.5 in. (38 mm)
	Rewind	0.25 in. (6 mm)
Total media width (label + backing, if any)	Minimum	2.00 in. (51 mm)
	Maximum	7.1 in. (180 mm)
Total thickness (includes backing, if any)	Minimum	0.003 in. (0.076 mm)
	Maximum	0.012 in. (0.305 mm)
Cutter maximum full-width media thickness		0.007 in. (0.18 mm)
Roll media core inside diameter		3 in. (76 mm)
Maximum roll diameter		8.0 in. (203 mm)
Inter-label gap	Minimum	0.079 in. (2 mm)
	Maximum	0.118 in. (3 mm)
Maximum internal fanfold media pack size (label + backing) L×W×H		8.0×7.1×4.5 in. (203×114×114 mm)
Ticket/tag sensing notch L×W		0.12×0.25 in.(3×6 mm)
Ticket/tag sensing hole diameter		0.125 in.(3 mm)
Effective leading edge registration accuracy (vertical)		± 0.060 in. (± 1.5 mm)
Effective leading edge registration accuracy (horizontal)		± 0.060 in. (± 1.5 mm)

BP-360X-Plus II Black Mark Sensing Only

Media Specifications		BP-360X-Plus II
Mark length (measuring parallel to label or tag edge)	Minimum	0.12 in. (3 mm)
	Maximum	0.43 in. (11 mm)
Mark width (measuring to perpendicular label or tag edge)	Minimum	0.43 in. (11 mm)
	Maximum	Full media width
Mark location		within 0.040 in. (1 mm) of the inside media edge
Mark density in Optical Density Unit (ODU)		>1.0

Glossary

alphanumeric Indicating letters, numerals, and characters such as punctuation marks.

backfeed When the printer pulls the media and ribbon (if used) backward into the printer so that the beginning of the label to be printed is properly positioned behind the printhead. Backfeed occurs when operating the printer in Tear-Off and Applicator modes.

bar code A code by which alphanumeric characters can be represented by a series of adjacent stripes of different widths. Many different code schemes exist, such as the universal product code (UPC) or Code 39.

black mark A registration mark found on the underside of the print media that acts as a start-of-label indication for the printer. (See *continuous media*.)

calibration (of a printer) A process in which the printer determines some basic information needed to print accurately with a particular media and ribbon combination. To do this, the printer feeds some media and ribbon (if used) through the printer and senses whether to use the direct thermal or thermal transfer print method, and (if using non-continuous media) the length of individual labels or tags.

character set The set of all letters, numerals, punctuation marks, and other characters that can be expressed by a particular font or bar code.

check digit A character added to a bar code symbol that indicates to the scanner that it has read the symbol correctly.

configuration The printer configuration is a group of operating parameters specific to the printer application. Some parameters are user selectable, while others are dependent on the installed options and mode of operation. Parameters may be switch selectable, control panel programmable, or downloaded as ZPL II commands. A configuration label listing all the current printer parameters may be printed for reference.

continuous media Label or tag-stock media that has no notch, gap, or web (media liner only) to separate the labels or tags. The media is one long piece of material.

core diameter The inside diameter of the cardboard core at the center of a roll of media or ribbon.

diagnostics Information about which printer functions are not working that is used for troubleshooting printer problems.

die-cut media A type of label stock that has individual labels stuck to a media liner. The labels may be either lined up against each other or separated by a small distance. Typically the material surrounding the labels has been removed. (See *non-continuous media*.)

direct thermal A printing method in which the printhead presses directly against the media. Heating the printhead elements causes a discoloration of the heat-sensitive coating on the media. By selectively heating the printhead elements as the media moves past, an image is printed onto the media. No ribbon is used with this printing method. Contrast this with *thermal transfer*.

direct thermal media Media that is coated with a substance that reacts to the application of direct heat from the printhead to produce an image.

dynamic RAM The memory devices used to store the label formats in electronic form while they are being printed. The amount of DRAM memory available in the printer determines the maximum size and number of label formats that can be printed. This is volatile memory that loses the stored information when power is turned off.

fanfold media Media that comes folded in a rectangular stack. Contrast this with *roll media*.

firmware This is the term used to specify the printer's operating program. This program is downloaded to the printer from a host computer and stored in FLASH memory. Each time the printer power is turned on, this operating program starts. This program controls when to feed the media forward or backward and when to print a dot on the label stock.

FLASH memory FLASH memory is non-volatile and maintains the stored information intact when power is off. This memory area is used to store the printer's operating program. In addition, this memory can be used to store optional printer fonts, graphic formats, and complete label formats.

Font A complete set of alphanumeric characters in one style of type. Examples include CG Times™, CG Triumvirate Bold Condensed™.

ips (inches-per-second) The speed at which the label or tag is printed. Brady printers can print from 1 ips to 12 ips.

label An adhesive-backed piece of paper, plastic, or other material on which information is printed.

label backing (liner) The material on which labels are affixed during manufacture and which is discarded or recycled by the end-users.

liquid crystal display (LCD) The LCD is a back-lit display that provides the user with either operating status during normal operation or option menus when configuring the printer to a specific application.

light emitting diode (LED) Indicators of specific printer status conditions. Each LED is either off, on, or blinking depending on the feature being monitored.

lock-up This is the term generally used to describe a fault condition that, for no apparent reason, causes the printer to stop working.

media Material onto which data is printed by the printer. Types of media include: tag stock, die-cut labels, continuous labels (with and without media liner), non-continuous media, fanfold media, and roll media.

media sensor This sensor is located behind the printhead to detect the presence of media and, for non-continuous media, the position of the web, hole, or notch used to indicate the start of each label.

non-continuous media Media that contains an indication of where one label/printed format ends and the next one begins. Examples are die-cut labels, notched tag-stock, and stock with black mark registration marks.

non-volatile memory Electronic memory that retains data even when the power to the printer is turned off.

notched media A type of tag stock containing a cutout area that can be sensed as a start-of-label indicator by the printer. This is typically a heavier, cardboard-like material that is either cut or torn away from the next tag. (See *non-continuous media*.)

peel-off A mode of operation in which the printer pauses to allow the user to peel a printed label away from the backing before another label is printed. Printing pauses until the label is removed.

print speed The speed at which printing occurs. For thermal transfer printers, this speed is expressed in terms of ips (inches per second). Brady offers printers that can print from 1 ips to 12 ips.

printhead wear The degradation of the surface of the printhead and/or the print elements over time. Heat and abrasion can cause printhead wear. Therefore, to maximize the life of the printhead, use the lowest print darkness setting (sometimes called burn temperature or head temperature) and the lowest printhead pressure necessary to produce good print quality. In the thermal transfer printing method, use ribbon that is as wide or wider than the media to protect the printhead from the rough media surface.

registration Alignment of printing with respect to the top of a label or tag.

ribbon A band of material consisting of a base film coated with wax or resin “ink.” The inked side of the material is pressed by the printhead against the media. The ribbon transfers ink onto the media when heated by the small elements within the printhead. Brady ribbons have a coating on the back that protects the printhead from wear.

ribbon wrinkle A wrinkling of the ribbon caused by improper alignment or improper printhead pressure. This wrinkle can cause voids in the print and/or the used ribbon to rewind unevenly. This condition should be corrected by performing adjustment procedures.

roll media Media that comes supplied rolled onto a core (usually cardboard). Contrast this with *fanfold media*.

supplies A general term for media and ribbon.

symbology The term generally used when referring to a bar code.

tag A type of media having no adhesive backing but featuring a hole or notch by which the tag can be hung on something. Tags are usually made of cardboard or other durable material.

tear-off A mode of operation in which the user tears the label or tag stock away from the remaining media by hand.

thermal transfer A printing method in which the printhead presses an ink or resin coated ribbon against the media. Heating the printhead elements causes the ink or resin to transfer onto the media. By selectively heating the printhead elements as the media and ribbon move past, an image is printed onto the media. Contrast this with *direct thermal*.

void A space on which printing should have occurred, but did not due to an error condition such as wrinkled ribbon or faulty print elements. A void can cause a printed bar code symbol to be read incorrectly or not at all.

Index

A

- active control panel buttons, 11
- adhesive test for ribbon coating, 29
- adjustments
 - LCD, 88
 - left position, 83
 - lower media sensor, 52
 - media sensors, 50
 - print darkness, 64
 - printhead toggle pressure, 53
 - tear-off position, 65
 - upper media sensor, 50
- agency approvals, 178
- applicator
 - +24-28V isolated and non-isolated modes, 174
 - +5V isolated and non-isolated modes, 173
 - applicator interface connector, 168
 - interface pin configuration, 170
 - signals during applicator modes, 168
- applicator port setting, 86
- auto-calibration, 48

B

- backfeed setting, 82
- backing removal, 120
- bar codes
 - list available codes, 72
 - types of codes, 177
- baud setting, 78
- before you begin setup, 16
- bitmap scaling factor, 88

- black mark media
 - described, 26
 - when to clean sensor, 124
- BP-300X-Plus II
 - black mark specifications, 183
 - label specifications, 182
 - print specifications, 180
 - ribbon specifications, 181
- BP-360X-Plus II
 - black mark specifications, 184
 - label specifications, 183
 - print specifications, 180
 - ribbon specifications, 181
- BP-600X-Plus II
 - black mark specifications, 183
 - label specifications, 182
 - print specifications, 180
 - ribbon specifications, 181

C

- cable requirements, 23
- CALIBRATE button function, 11
- calibration
 - CALIBRATE button, 11
 - media and ribbon sensor, 77
 - methods, 48
 - setting for head close, 82
 - setting for media power up, 81
 - troubleshooting problems, 146
- Canadian DOC compliance, iv
- CANCEL button
 - CANCEL self test, 152
 - function, 11

- checklist
 - before you begin, 16
 - troubleshooting, 138
 - cleaning
 - cutter, 133
 - exterior of printer, 125
 - media compartment, 125
 - printhead and platen roller, 125
 - recommended schedule, 124
 - sensors, 128
 - snap plate, 131
 - communication interfaces
 - overview and location, 19
 - types of connections, 20
 - communications diagnostics test
 - overview, 159
 - selecting, 80
 - communications problems, 147
 - CompactFlash card
 - initialization, 74
 - components, 9
 - configuration
 - changing parameters, 63
 - enter Setup mode, 58
 - exit Setup mode, 59
 - software or printer driver, 63
 - configuration label
 - printing using CANCEL self test, 152
 - printing using List Setup command, 73
 - connect to power source, 24
 - contacts, 3
 - continuous media
 - described, 27
 - setting media type, 66
 - control panel
 - buttons, 11
 - enter Setup mode, 58
 - exit Setup mode, 59
 - illustration, 10
 - indicator lights, 13
 - LCD error messages, 139
 - LCD functions, 11
 - location, 8
 - parameters, 63
 - control prefix setting, 80
 - customer service, 3
 - cutter
 - cleaning, 133
 - Cutter Jam** message, 142
 - selecting Cutter mode, 65
 - set up Cutter Mode, 100
 - set up Rewind Mode with Cutter option, 112
 - when to clean, 124
- ## D
- darkness setting, 64
 - data bits setting, 78
 - data cable requirements, 23
 - data ports, 161
 - data source
 - communication interfaces, 161
 - connections, 19
 - site selection, 18
 - date setting, 88
 - DB-9 to DB-25 connection, 167
 - declaration of conformity
 - CE, v
 - FCC, iii
 - default password, 60
 - defragmenting, 141
 - delimiter character setting, 81
 - diagnostics, 151
 - direct thermal mode
 - media scratch test, 28
 - setting, 66
 - disable password protection, 60
 - display language
 - changing from unreadable language, 149
 - selection, 89
 - disposal of printer, 17
 - dpi format conversion, 88
- ## E
- electrical noise, 23
 - electrical specifications, 179
 - electronics cover, 8
 - enter Setup mode, 58
 - environmental specifications, 179
 - error messages, 139
 - Error mode, 11
 - exit Setup mode, 59
 - exterior cleaning, 125
 - external view of printer, 8

F

- factory defaults
 - reload parameters, 59
 - restore network settings, 59
- fanfold media, 27
- FCC compliance, iv
- features, 176
- FEED button
 - FEED and PAUSE self test, 158
 - FEED self test, 154
 - function, 11
- Flash memory, 75
- font list, 72
- format convert setting, 88
- format list, 73
- format memory card, 74
- format prefix setting, 80
- fuse replacement, 134

H

- hardware control signal descriptions, 164
- HEAD COLD** message, 141
- head test setting, 84
- HEAD TOO HOT** message, 140
- host handshake setting, 79
- humidity requirements, 18

I

- idle display setting, 88
- images list, 73
- initialize Flash memory, 75
- initialize memory card, 74
- inspect for shipping damage, 17
- interfaces
 - IEEE 1284 bidirectional parallel, 21
 - print servers, 22
 - RS-232 serial, 20
 - USB, 22
- international safety organization marks, 25
- isolated mode for applicator control signals
 - +24-28V operation, 174
 - +5V operation, 173

J

- jumper configurations for +24-28V operation, 174
- jumper configurations for +5V operation, 173

L

- label backing removal, 120

- label length maximum setting, 68
- label specifications, 182
- label top
 - printer cannot detect, 150
 - setting, 82
- label-available sensor
 - location, 128
 - when to clean, 124
- labels did not print, 147
- language
 - changing from unreadable language, 149
 - selection, 89
- LCD messages
 - adjust LCD settings, 88
 - error messages, 139
 - language selection, 89
 - Setup mode, 63
- liability, ii
- list settings
 - all settings, 73
 - bar codes, 72
 - fonts, 72
 - formats, 73
 - images, 73
 - setup, 73
- load factory defaults, 59
- loading
 - ribbon, 41
- long calibration, 48
- lower media sensor adjustment, 52

M

- mark LED setting, 87
- Mark Med S. setting, 87
- maximum label length setting, 68
- media
 - continuous roll media, 27
 - fanfold, 27
 - loading, 34
 - media LED setting, 87
 - non-continuous roll media, 26
 - ordering, 3
 - setting media type, 66
 - specifications, 182
 - types of media, 26
- media and ribbon sensor calibration procedure, 77
- media compartment cleaning, 125
- media door, 8
- media liner removal, 120

- media loading
 - Cutter Mode, 100
 - Peel-Off Mode, 93
 - Rewind Mode, 105
 - Rewind Mode with Cutter option, 112
 - Tear-Off mode, 35
- media path cleaning, 124
- media power up setting, 81
- Media S. setting, 87
- media scratch test, 28
- media sensor
 - adjustments, 50
 - location, 130
 - print sensor profile, 76
 - sensor sensitivity calibration, 49
- modem connection, 167

N

- network configuration label
 - printing, 62
- network ID setting, 79
- NEXT/SAVE button function, 12
- non-continuous media
 - described, 26
 - setting media type, 66
- non-isolated mode for applicator control signals
 - +28V operation, 174
 - +5V operation, 173

O

- operating conditions, 18
- Operating mode, 11
- optional print servers, 22
- ordering ribbon and media, 3
- OUT OF MEMORY** message, 142

P

- PAPER OUT** message, 140
- parallel port
 - cabling requirements, 162
 - location, 19
 - overview, 21
 - pin configuration, 162
 - setting parallel communications, 78
 - settings, 162
- parity setting, 79
- passwords
 - default, 60
 - disable, 60
 - entering, 60

- PAUSE button
 - FEED and PAUSE self test, 158
 - function, 11
 - PAUSE self test, 153
- Pause mode, 11
- PCMCIA card
 - initialization, 74
- Peel-Off mode
 - loading media, 93
 - selecting, 65
- physical specifications, 179
- pin configuration
 - applicator interface, 170
 - parallel port, 162
 - serial port, 165
- platen roller
 - cleaning, 125
 - when to clean, 124
- ports, 161
- power
 - connect to power source, 24
 - power cord specifications, 25
 - site selection, 18
- Power-On Self Test (POST), 151
- PREVIOUS button function, 11
- print configuration label
 - CANCEL self test, 152
 - List Setup command, 73
- print darkness setting, 64
- print modes
 - Cutter Mode, 100
 - features, 176
 - load media for different modes, 34
 - Peel-Off Mode, 93
 - Rewind Mode, 105
 - Rewind Mode with Cutter option, 112
 - selecting, 65, 92
- print network configuration label
 - instructions and sample label, 62
- print quality
 - effect of printhead toggle pressure, 53
 - troubleshooting, 143
- print server options, 22
- print width setting, 67
- printer components, 9
- printer diagnostics, 151
- printer modes, 11
- printer operation, 31

printer settings

- applicator port, 86
- backfeed, 82
- baud, 78
- control prefix, 80
- data bits, 78
- date, 88
- delimiter character, 81
- format convert, 88
- format prefix, 80
- head resistor, 85
- head test count, 84
- host handshake, 79
- idle display, 88
- label top, 82
- language, 89
- LCD, 88
- left position, 83
- maximum label length, 68
- media type, 66
- network configuration label as baseline, 62
- network ID, 79
- parallel communications, 78
- parity, 79
- print darkness, 64
- print method, 66
- print width, 67
- protocol, 79
- resynch mode, 87
- saving, 59
- serial communications, 78
- setting through control panel, 58
- start print signal, 86
- time, 88
- verifier port, 85
- ZPL mode, 81

printhead

- cleaning, 125
- head close setting, 82
- head resistor value setting, 85
- head test count setting, 84
- pressure adjustment, 53
- when to clean, 124

product markings, 178

protocol setting, 79

R

recycling the printer, 17

registration problems, 146

relative humidity requirements, 18

remove media liner from rewind spindle, 120

replace fuse, 134

report shipping damage, 17

restore

- factory default settings, 59
- network settings, 59

resynch mode setting, 87

Rewind Mode

- install rewind plate, 119
- loading media, 105
- loading media with Cutter option, 112

Rewind mode

- selecting, 65

rewind plate installation, 119

rewind spindle, 120

ribbon

- adhesive test, 29
- determining coated side, 28
- loading, 41
- ordering, 3
- removal, 46
- ribbon LED setting, 87
- scratch test, 29
- specifications, 181
- when to use, 28

RIBBON IN message, 140

RIBBON OUT message, 139

Ribbon S. setting, 87

ribbon sensor

- calibration procedure, 77
- cleaning, 128
- location, 128
- sensitivity calibration, 49
- when to clean, 124

roll media

- described, 26

routine maintenance, 123

RS-232 serial interface, 20

- connections, 166

RTC (real-time clock) setting

- date, 88
- idle display, 88
- time, 88

S

sales, 3

schedule for cleaning, 124

scratch test

- media type, 28
- ribbon coated side, 29

selecting a print mode, 92

self tests, 151

- CANCEL, 152
- communications diagnostics, 159
- FEED, 154
- FEED and PAUSE, 158
- PAUSE, 153
- Power-On Self Test (POST), 151

sensor profile

- calibration types, 49
- print, 76

sensors

- cleaning, 128
- interpreting sensor profile, 160
- label-available sensor location, 128
- lower media sensor adjustment, 52
- ribbon sensor location, 128
- sensor profile, 76
- transmissive (media) sensor adjustment, 50
- transmissive (media) sensor location, 130
- upper media sensor adjustment, 50

serial port

- location, 19
- overview, 20
- pin configuration, 165
- setting serial communications, 78
- settings, 164

setup

- checklist, 16
- unpack the printer, 17

Setup mode

- defined, 11
- enter Setup mode, 58
- exit Setup mode, 59
- LCD messages, 63
- passwords, 60

SETUP/EXIT button function, 11

shipping

- report damage, 17
- reshipping the printer, 17

short calibration, 48

snap plate

- cleaning, 131
- when to clean, 124

spacing requirements, 18

specifications

- agency approvals and markings, 178
- by model number, 180
- electrical, 179
- environmental, 179
- physical, 179
- power cord, 25
- ribbon, 181

standard data ports, 161

standard features, 176

start print signal setting, 86

storing the printer, 17

surface for the printer, 18

T

tag stock

- described, 26

Tear-Off mode

- loading media, 35
- selecting, 65
- tear-off bar cleaning, 124
- tear-off position adjustment, 65

technical support, 3

temperature requirements, 18

thermal transfer mode

- media scratch test, 28
- setting, 66

time setting, 88

timing diagrams for applicator signals, 168

toggle pressure adjustment, 53

top of label

- printer cannot detect, 150
- setting, 82

transmissive (media) sensor

- adjustment, 50
- location, 130
- when to clean, 124

troubleshooting

- checklist, 138
- communications problems, 147
- diagnostic tests, 151
- LCD error messages, 139
- print quality problems, 143

types of media

- continuous roll media, 27
- fanfold media, 27
- non-continuous roll media, 26

U

- unpack the printer, 17
- upper media sensor adjustment, 50
- USB port
 - location, 19
 - overview, 22

V

- verifier port setting, 85

W

- web media, 26
- Web S. setting, 87

Z

- Zebra Programming Language (ZPL)
 - features, 176
 - ZPL mode setting, 81



Notes • _____



United States

Brady Worldwide Identification Solutions
6555 West Good Hope Road
P.O. Box 2131
Milwaukee, WI 53201-2131
<http://www.bradyid.com>
Telephone: +1.800.537.8791
Fax: +1 800.292.2289

European Union (EU)

W.H.Brady n.v.
Industriepark C3
Lindestraat 20
B-9240 Zele
Belgium
<http://www.bradyeurope.com>
Telephone: 32 (0) 52 457 811
Fax: 32 (0) 52 457 812

Asia Pacific

Brady Corporation Asia Pte Ltd
1 Kaki Bukit Crescent
Singapore 416236
<http://www.bradyid.com.sg>
Telephone: 65-6477-7261
Fax: 65-6383-2229

Free Manuals Download Website

<http://myh66.com>

<http://usermanuals.us>

<http://www.somanuals.com>

<http://www.4manuals.cc>

<http://www.manual-lib.com>

<http://www.404manual.com>

<http://www.luxmanual.com>

<http://aubethermostatmanual.com>

Golf course search by state

<http://golfingnear.com>

Email search by domain

<http://emailbydomain.com>

Auto manuals search

<http://auto.somanuals.com>

TV manuals search

<http://tv.somanuals.com>