

OWNER'S MANUAL

Bravetti
PLATINUM PRO

4-in-1 MULTI-USE Mixer

Model EP559V2



EURO-PRO Operating LLC
Boston, MA, 02465
1 (800) 798-7398
www.euro-pro.com

EURO-PRO 

IMPORTANT SAFETY INSTRUCTIONS

When using your **Bravetti Platinum Pro 4-in-1 Multi-Use Mixer**, basic safety precautions should always be observed, including the following:

1. Read all instructions before using the appliance.
2. Use the appliance only for its intended use.
3. To protect against a risk of electric shock, do not immerse cord, plug or unit (body of mixer) in water or other liquids.
4. Never yank cord to disconnect from outlet; instead, grasp plug and pull to disconnect.
5. Unplug appliance from outlet when not in use, before putting on or taking off parts and before cleaning.
6. Avoid contact with moving parts at all times. Keep hands, hair, clothing, as well as spatulas and other utensils away from beaters during operation to prevent personal injury and/or damage to the mixer.
7. **Do not** operate any appliance with a damaged cord or plug, or after the appliance malfunctions, or is dropped or damaged in any manner. To avoid the risk of electric shock, do not disassemble or attempt to repair the mixer. Return the appliance to **EURO-PRO** Corporation (see warranty) for examination and repair.
8. Close supervision is necessary for any appliance being used by or near children. **Do not** leave the mixer unattended while connected.
9. The use of attachments not recommended or sold by EURO-PRO Operating LLC may cause fire, electric shock or injury.
10. **Do not** use outdoors.
11. **Do not** let cord hang over edge of table or counter or touch hot surfaces, including the stove.
12. To avoid injury by accidentally switching on the appliance when inserting the dough hooks, beaters, chopper and hand blender attachment, always set the switch to position "0" and unplug the appliance before assembling or disassembling. Remove beaters, dough hooks, whisk, hand blender and chopper attachments from mixer before cleaning.
13. **DO NOT USE THIS APPLIANCE ON A STOVE.**
14. When mixing liquids, especially hot liquids, use a tall container or make small quantities at a time to reduce spillage.
15. Keep hands and utensils out of the container while blending to prevent possibility of severe injury to persons or damage to the unit. A spatula may be used but must be used **ONLY** when the unit is not running.
16. **WARNING! Blades are sharp.** Handle carefully. When handling the chopper blade, always hold it by the spindle.
17. Make sure that the chopper bowl is securely locked in place before operating appliance.
18. **Do not** attempt to alter the chopper cover interlock mechanism.
19. The unit is designed for intermittent use. Do not press the switch down or tamper with the switch to fix it down over 1 minute for blender or 15 seconds for chopper to prevent overheating the unit.
20. The beaker may be used only with the hand blender for processing small quantities. It should not be used with the beaters, whisk or dough hooks.
21. To avoid burns, place blender attachment first in the food to be beaten or chopped before pressing the switch button. Always release the button before removing the blender from the food.
22. **Do not** place containers in the microwave.
23. Remove beaters, whisk or dough hooks from mixer before washing.

IMPORTANT NOTICE

This appliance has a polarized plug (one blade is wider than the other). To reduce the risk of electric shock, this plug will fit in a polarized outlet only one way. If the plug does not fit fully in the outlet, reverse the plug. If it still does not fit, contact a qualified electrician. Do not modify the plug in any way.

SAVE THESE INSTRUCTIONS

For Household Use Only

GETTING TO KNOW YOUR 4-IN-1 MULTI-USE MIXER

Congratulations! As the owner of a new **Bravetti Platinum Pro "4-in-1 Multi-Use"**, you are about to use a very versatile and powerful kitchen mixing, chopping, and blending tool. **Bravetti Platinum Pro** products are engineered to meet the highest quality standards and are designed to offer the ultimate in ease of operation and convenience.

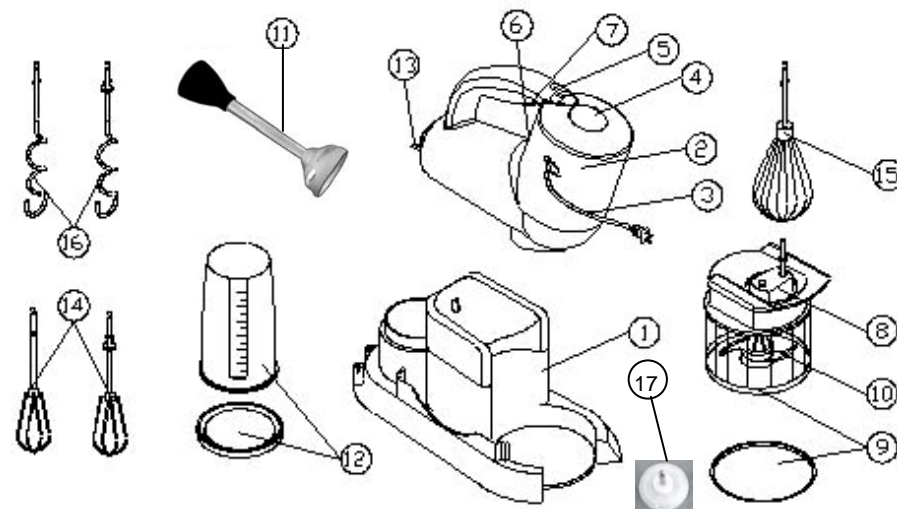

Main Components

- | | |
|---------------------------|-----------------------------|
| 1. Main Stand | 9. Chopping Bowl With Cover |
| 2. Main Unit | 10. Chopper Blade |
| 3. Retractable Power Cord | 11. Stick Blender |
| 4. Cord Rewind Button | 12. Beaker and Cover |
| 5. Speed Control Switch | 13. Safety Cover |
| 6. Beater Release Button | 14. Beaters (2) |
| 7. Blender Switch | 15. Whisk (1) |
| 8. Gear Box | 16. Dough Hooks (2) |
| | 17. Blade Support |

Technical Specifications

Voltage: 120V~ 60Hz.
Power: 550 Watts

OPERATING INSTRUCTIONS

Before using your **Bravetti Platinum Pro Multi-Use Mixer** for the first time, wash the beaters, dough hooks, whisk and containers in warm, sudsy water. Rinse and dry thoroughly.

Warning: To avoid injury when inserting or removing beaters, dough hooks, whisk, hand blender or chopper, always set the speed selector on "0" and unplug the appliance.

Warning: The unit is designed for intermittent use. The maximum operating time on settings "0-Max" is 5 minutes non-stop with beaters, dough hooks, or whisk. Maximum running time with the chopper is 3 minutes and with the hand blender 2 minutes.

Beaters, Dough Hooks, Whisk:

Select the attachment according to the type of mixing required. Make sure that the mixer is unplugged from power source and speed selector is set on "0" before inserting or removing beaters, dough hooks or whisk.

Beaters:

Use for liquid mixes such as creams, egg-whites, confectionery doughs, etc. insert stem end of beaters (one at a time) into the openings in the mixer. Insert the beater with the metal ring in the larger of the two holes. The metal ring on the beater must sit below the surface of the mixer housing. To ease the inserting of the beaters, a slight twisting motion will aid in engaging the beater drive tabs. Install the second beater in the same manner as above. (If there is no ring on one of your beaters, either beater can be inserted into either hole of the mixer.)

Dough hooks:

Use for light doughs. Insert dough hooks in the same way as beaters above. See installing instructions for beaters above. Always use both dough hooks. Never try to work with one beater and one dough hook at the same time. **Do not** use dough hooks at low speeds as this may cause motor to overheat. When using dough hooks for heavy or thick dough, use only high speed (MAX) from the beginning to prevent the motor from overheating (blocking).

Whisk:

The whisk is used to beat air into mixtures such as egg whites, yolks or cream. To insert whisk: There is only one whisk provided. Hold whisk at stem end and insert into one of the holes until it clicks into place. **DO NOT PUSH WHISK IN FROM THE WIRE END AS WIRES MAY BE DAMAGED.**

Adjustable Speed Control:

The speed control switch provides variable speed selection.

Please Note: The stick blender operates on one speed **ONLY** - for

safety reasons the speed selector switch will not function with the stick blender.

Warning: Never operate the appliance without all the parts in place. Make sure that **all** parts are properly assembled before turning on the unit.

Stick Blender:

1. Make sure that the unit is unplugged from power source before attaching or removing the stick blender.
2. Remove the unit from the main stand and open the safety cover.
3. Align the arrow on the stick blender with the arrow on the main unit. Once fully inserted, turn clockwise 90° to lock.

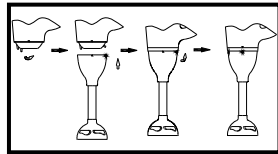

Warning: This appliance is designed for intermittent use. Maximum running time with the hand blender is 2 minutes. After this time, allow the unit to cool.

4. To avoid spattering, place the stick blender first in the food to be beaten or chopped and then press the blender switch. **Do not** use the stick blender in boiling or very hot ingredients. **Do not** use on stove.

OPERATING INSTRUCTIONS cont.

5. Always release the blender switch before removing the stick blender from the food, especially when using the stick blender in liquids. Always hold the unit with your hand while processing. Never leave unit unattended while plugged in .

Caution: Do not use the stick blender on the stove. If you want to use it in a saucepan while cooking, you must first remove saucepan from the stove and allow it to cool before using the stick blender.

6. To remove the stick blender from the main unit, first unplug the unit from the power source and then turn the stick blender 90° counter clockwise and pull off.

Beaker:

Use the beaker with with the stick blender or you can use any other container.

Do not use the beaker in the microwave oven.

Do not use the beaker with beaters, whisk or dough hooks. The beaker is intended only for processing small quantities with the stick blender.

Hand Mixer:

To avoid spattering, always put beaters, dough hooks or whisk into the ingredients to be mixed before starting the mixer. Make sure that the rear safety cover is properly closed, otherwise, for safety reasons the unit will not operate.

1. Select the required speed using your thumb to slide the speed control switch to the required position: "0 - Max".

Low Speeds are suggested for starting and blending dry and liquid ingredients, folding in egg whites or to break up potatoes for mashing.

Medium speeds are suggested for beating egg whites, yolks or whole eggs and whipping cream.

Higher speeds are suggested for all medium speed applications as well as light cake batters, and whipping cream or mashing potatoes. Also for mixing bread doughs with the dough hooks. We recommend that you start at low speed and gradually increase the speed as required. For difficult or thick mixtures, use "MAX" speed from the outset to prevent the motor from overloading.

Caution: When using dough hooks for heavy or thick dough, use only MAX speed from the outset to prevent the motor from overheating. Always make sure that the beaters are free to rotate properly in the container.

Warning: To avoid personal injury and damage to beaters, do not attempt to scrape bowl while mixer is operating , turn mixer OFF. Should scraper or other object drop into bowl, turn motor OFF before removing.

To remove beaters, dough hooks, or whisk set speed selector on '0', unplug unit from power source, and press the release button to remove the beaters, dough hooks, or whisk from the hand mixer. This button only works if the speed control switch is set on '0'.

OPERATING INSTRUCTIONS cont.

CHOPPER:

Make sure that the unit is unplugged from power source and speed control switch is on "0" before inserting or removing the chopper attachment.

Warning: Use extreme caution- blades are sharp. Always hold the chopper blade by the spindle.

1. Remove the blade cover from the chopper blade.
2. Place the blade support into the chopping bowl ensuring that the locator pins are engaged.
3. Put the blade assembly on the blade support of the chopper bowl .
4. Place the chopper bowl on the anti-skid base (bowl cover).
5. Place the food to be chopped in the bowl.
6. Position the gear box on the chopper bowl, fitting the grooves on the gear box and bowl so that they engage the bowl.
7. Insert the gear box drive shaft into the corresponding opening on the bottom of the hand mixer until the gear box is securely locked in place.

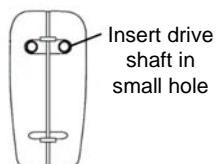
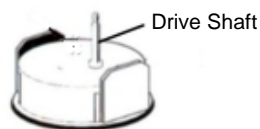

WARNING: This appliance is designed for intermittent use. Maximum running time with chopper is 3 minutes. After 3 minutes, allow the unit to cool.

Caution: Always hold the hand mixer with your hand while processing. Do not leave the appliance unattended when plugged in.

Do not use to chop very hard foods such as coffee beans or nutmeg. Use for hard cheese, carrots, onions, tomatoes, parsley, etc.

Important: To mince meat, cut the meat into 1" cubes and do not mince more than 200 grams (7 ounces) at once. Make sure the meat is fully defrosted and all bones and gristle have been removed.

Always allow cooked food to cool before placing in the chopping bowl. The anti-skid base can also be used as a cover for the chopper bowl.

Note: The processing time required depends upon the type and quantity of food to be processed and on the degree of fineness you require. Meat (200 grams/7 ounces - 1 inch cubes), hard cheese (100 grams/3 1/2 ounces - 1 inch pieces) and carrots (150 grams/5 1/4 ounces - cut in pieces) usually would require approximately 15 seconds. Onions (quartered) require approximately 5-10 seconds. Parsley (stems removed) approximately 15-20 seconds.

OPERATING INSTRUCTIONS cont.

ICE CRUSHING:

Caution: Always unplug the unit from power outlet before changing or assembly of accessories.

1. Place the blade support and the chopping blade into the chopping bowl.
2. Add ice to be crushed. **Do not** attempt to chop more than four or five ice cubes at a time.
3. Install the gearbox as per chopping instructions on page 4.
4. Plug the unit into the power outlet.
5. Firmly hold the chopping bowl with one hand while momentarily depressing the power switch on the main unit. **Do not** run the unit continuously for more than 4 seconds at a time when crushing ice. Use short bursts of power.

CLEANING & MAINTENANCE:

- Make sure that the unit is switched "OFF" and disconnected from power outlet before cleaning.
- **Never immerse** the hand mixer or power cord in water or any other liquid.
- **Beaters, Dough Hooks and Whisk:** Eject beaters, dough hooks and whisk from mixer and wash in warm soapy water as soon as possible after use before foods set and dry. Rinse and dry after washing. Beaters, dough hooks and whisk can be washed in dishwasher.
- **Stick Blender Attachment:** Use caution - blade is sharp. Detach stick blender from mixer and wash with warm soapy water. **Do not** use any sharp objects to clean residue under the blade, as this may damage the housing. Do not wash in dishwasher.
- **Chopper Attachment:** Use extra caution when handling the chopping blade. Always hold by the spindle. **Do not** immerse the gear box in water.
- Clean the stand with warm soapy water.
- The hand mixer unit, power cord and gear box should be wiped with a damp cloth and then dried thoroughly.
- Chopper blade, blade support, chopper bowl, beaker and anti-skid base/lids can be put in the dishwasher.

Free Manuals Download Website

<http://myh66.com>

<http://usermanuals.us>

<http://www.somanuals.com>

<http://www.4manuals.cc>

<http://www.manual-lib.com>

<http://www.404manual.com>

<http://www.luxmanual.com>

<http://aubethermostatmanual.com>

Golf course search by state

<http://golfingnear.com>

Email search by domain

<http://emailbydomain.com>

Auto manuals search

<http://auto.somanuals.com>

TV manuals search

<http://tv.somanuals.com>