

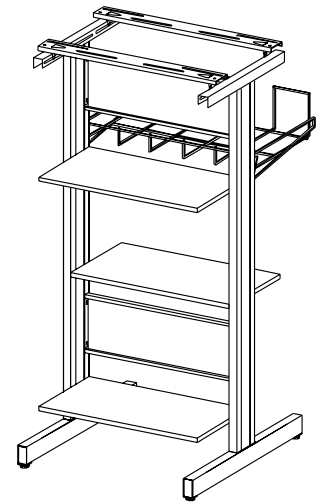

BRETFORD

UNI3 STAND-UP PRINTER STAND Assembly Instructions



PARTS LIST

Qty	Part#	Description
2	010-1627	Machine Rests
4	010-1629	Extender Brackets
2	010-1894	Modesty Panels
3	010-1824	Shelves
1	014-0166	Wire Basket
1	022-1381	Right Pedestal Assembly
1	022-1382	Left Pedestal Assembly

HARDWARE LIST

Ref	Qty	Part#	Description
AA	4	015-0045	Floor Glides
BB	32	030-0325	1/4-20 x 1/2" Truss Screws
CC	12	030-0207	1/4-20 Flanged Hex Nuts
DD	4	030-0313-901	Machine Rest Cups
EE	4	030-0272	1/4-20 x 1/2" Carriage Bolts
FF	4	030-0274	Lock Washers
GG	4	030-0006	1/4-20 Wing Nuts
	1	018-0034	13" Ground Wire

TOOLS REQUIRED

Phillips Screwdriver
Adjustable Wrench

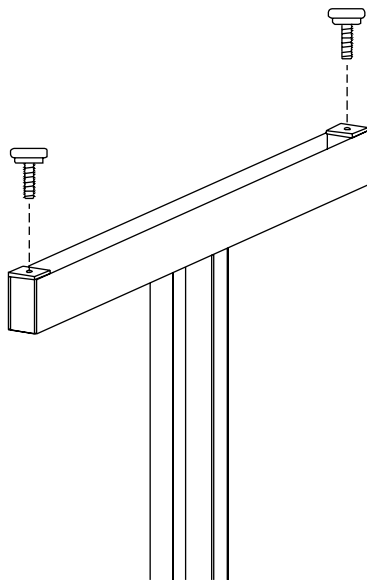

STEP 1

Twist on the floor glides (AA) onto the bottom of both pedestals.

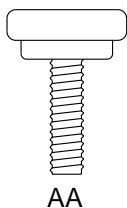

AA

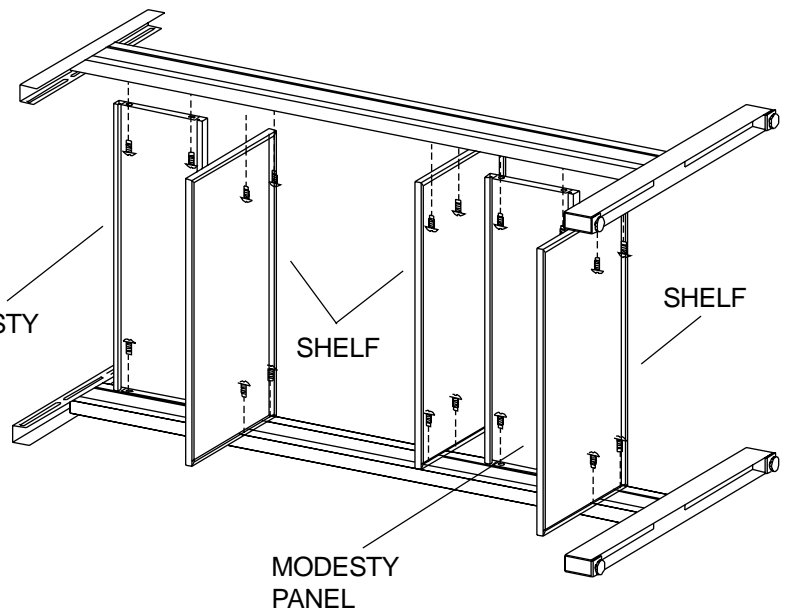

STEP 2

Lay left pedestal on a flat surface with holes facing upward. Attach modesty panels and shelves onto pedestal using screws (BB) in order shown. Position other pedestal on panels and attach with screws. Stand unit upright.

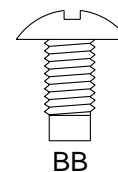

BB

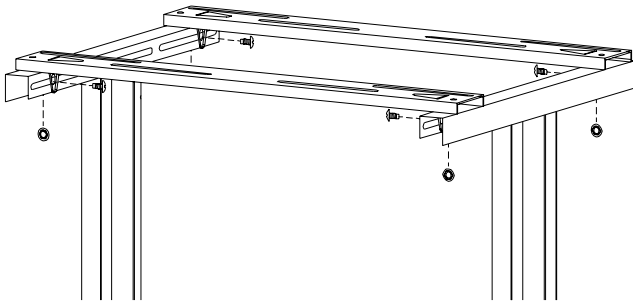

STEP 3

Attach machine rests between pedestals using screws (BB) and flange nuts (CC) as shown. The spacing of the machine rests is determined by your printer size.

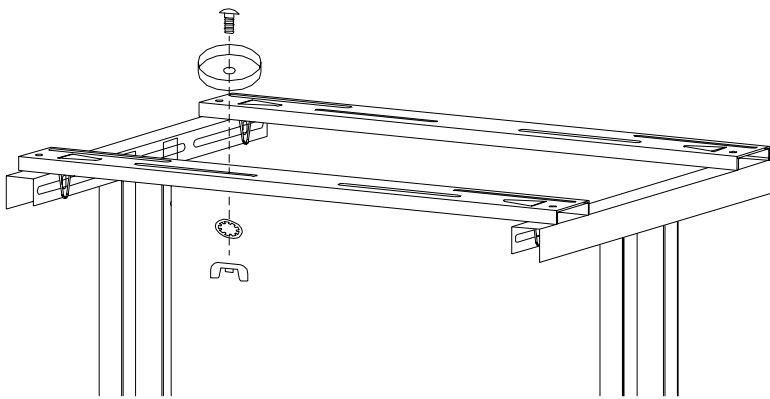
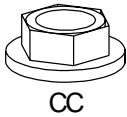

STEP 5

Fasten machine rest cups (DD) onto machine rests **OR** extender brackets (if used) using carriage bolts (EE), washer (FF) and wing nut (GG) as shown. The location of machine rest cups is determined by the printer size. Once everything is attached, place your printer on stand.

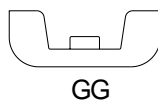
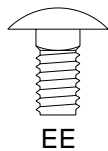
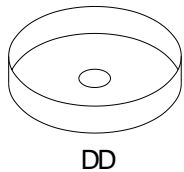

Bretford
 11000 Seymour Avenue
 Franklin Park, IL 60131
 TEL: 847.678.2545
 800.521.9614
 FAX: 847.678.0852
 800.343.1779

Bretford Ltd.
 Technology House
 7 Lake End Court, Taplow
 Bucks SL6 0JQ England
 TEL: 01628 603558
 FAX: 01628 604923

www.bretford.com

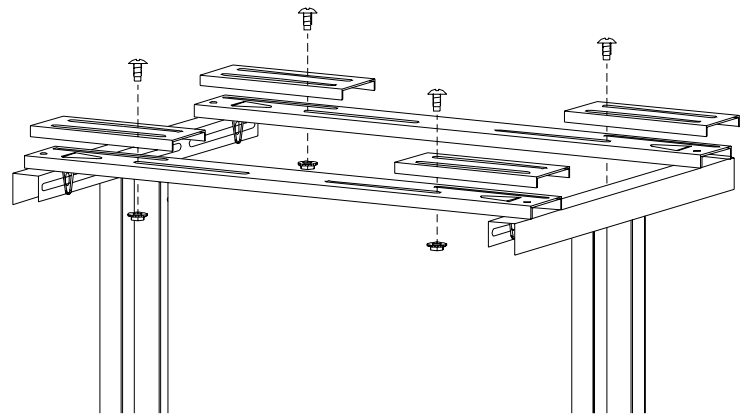

STEP 4

If printer is larger than printer stand, use the extender brackets to give you additional length. Place extender brackets on machine rests and fasten with screws (BB) and flange nuts (CC) as shown. Slide extender brackets out to desired.

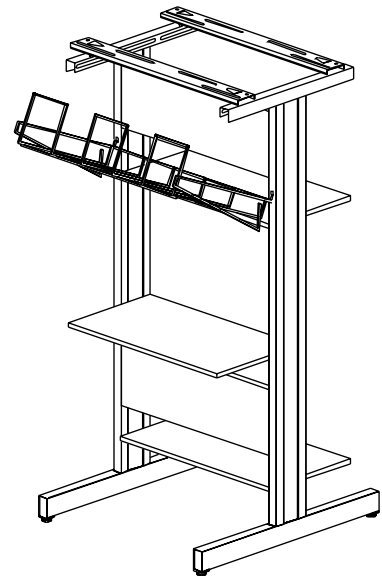

STEP 6

Hook wire basket into the slots on the back of the unit.

NOTE: Included in your hardware pack is ground wire. Consult your printer manual for proper procedures.

Part# 031-1050
 Rev. 09.24.97

Free Manuals Download Website

<http://myh66.com>

<http://usermanuals.us>

<http://www.somanuals.com>

<http://www.4manuals.cc>

<http://www.manual-lib.com>

<http://www.404manual.com>

<http://www.luxmanual.com>

<http://aubethermostatmanual.com>

Golf course search by state

<http://golfingnear.com>

Email search by domain

<http://emailbydomain.com>

Auto manuals search

<http://auto.somanuals.com>

TV manuals search

<http://tv.somanuals.com>