

WHERE BRIGGS & STRATTON MOTORS ARE MADE

YOUR Model "S" Gasoline Motor is one of the many thousands which are manufactured annually in this modern Briggs & Stratton factory at Milwaukee, Wisconsin. More small gasoline motors are produced here than in any other single plant in the world. The building is complete with all modern facilities for precision construction, economical production, rigid inspection and thorough testing. Briggs & Stratton gasoline motors, made here, are shipped to all parts of the world because of their established reputation for reliable service under widely varying conditions.

PRINTED IN U. S. A.

FORM 98277-90-B

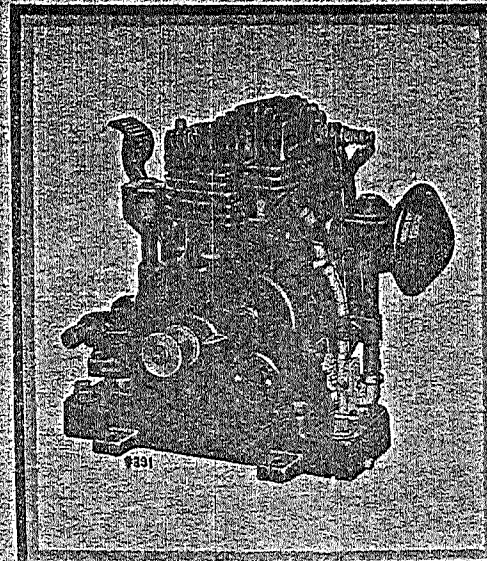

1/2 H.P.

OPERATING MANUAL *for* BRIGGS & STRATTON GASOLINE MOTOR

MODEL S

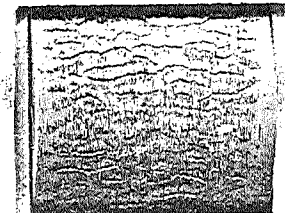
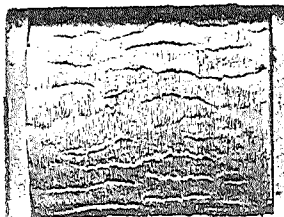

IMPORTANT SAFETY INFORMATION AND INSTRUCTIONS FOR ENGINE SELECTION ENGINE INSTALLATION ENGINE OPERATION

In the USA and Canada,
our 24 hour hotline is:

18002333723

Briggs & Stratton Corporation
Milwaukee, Wisconsin 53201

www.briggsandstratton.com

Keep these instructions for future reference.



Before installing and operating this engine read and observe all warnings, cautions and instructions on both sides of this sheet, on the engine, and in the operating & maintenance instructions.

NOTE: This sheet of instructions and safety information is not meant to cover all possible conditions and situations that may occur. Read entire Operating & Maintenance Instructions for this engine AND the instructions for the equipment this engine powers. Failure to follow instructions and safety information could result in serious injury or death.

The safety alert symbol () is used to identify safety information about hazards that can result in personal injury.

A signal word (DANGER, WARNING, or CAUTION) is used with the alert symbol to indicate the likelihood and the potential severity of injury. In addition, a hazard symbol may be used to represent the type of hazard.

 **DANGER** indicates a hazard which, if not avoided, will result in death or serious injury.

 **WARNING** indicates a hazard which, if not avoided, could result in death or serious injury.

 **CAUTION** indicates a hazard which, if not avoided, might result in minor or moderate injury.

CAUTION, when used **without** the alert symbol, indicates a situation that **could result in damage to the engine.**

HAZARD SYMBOLS AND MEANINGS



Fire



Explosion



Moving Parts



Toxic Fumes



Hot Surface



Shock



Kickback

(OVER)

FORM MS-6445-01/03

ENGINE SELECTION

 WARNING

Failure to select the correct engine could result in fire or explosion.

- Some engines are unique and designed for specific applications or types of equipment. If this engine will be used to build new equipment, contact Briggs & Stratton to ensure that the engine is appropriate for the intended use.
Note: For all Go-karts use only a model 136200 series engine, which offers improved safety and performance.
- Replacement engines should be the same model as the original engine, or be the Briggs & Stratton designated replacement engine. Refer to the Operation & Maintenance Instructions for engine identification information.
Note: For all Go-karts use only a model 136200 series engine, which offers improved safety and performance.
- Do not use Briggs & Stratton engines on 3-wheel All-Terrain Vehicles (ATVs), motor bikes, air craft products, or vehicles intended for use in competitive events. Briggs & Stratton does not approve of or authorize such uses.

ENGINE INSTALLATION

- [1] Do not attempt to install this engine if you do not have the appropriate tools and knowledge of small engine installation procedures. Use only Briggs & Stratton parts. Contact your Authorized Service Dealer for assistance.
- [2] Do not modify the engine in any way without Briggs & Stratton factory approval. Any such modification is at the owner's sole risk.
- [3] If the exhaust system on the old engine was supplied by the equipment manufacturer, you must transfer the exhaust system and related components (original muffler and related pipes, brackets, clamps, and shields) to the new engine. All components must be in good condition.
- [4]

 WARNING	Install muffler (and muffler deflector if used) so outlet points away from operator, fuel tank, and equipment, and so muffler heat will not damage or deform engine and components.
	
- [5]

 WARNING	Ensure all fuel lines and fittings are properly assembled and do not leak. Replacement parts must be the same model as the original.
	
- [6]

 WARNING	Ensure all wiring, including safety switches and engine shut-off components are completely installed and functioning properly.
	
- [7] Set engine speed to equipment manufacturer's specification. Refer to equipment manufacturer's manual. Do not tamper with governor springs, or other parts that will increase engine speed above specification.

- [8]







 WARNING	All engine parts, including fuel cap, spark plug, muffler, air cleaner, and covers and guards for drive components (gears, belts, shafts, couplings, etc.) must be in place before attempting to start engine.
	
- [9]

 WARNING	If engine is installed on walk behind lawn mower, all mower components, including cutting blade, must be correctly installed before attempting to start engine.
	
- [10]

 WARNING	When working on the engine or equipment, remove spark plug wire from spark plug. For electric start, remove negative wire from battery.
	
- [11]

 WARNING	Do not check for spark with spark plug removed. Use Briggs & Stratton spark tester #19368.
	

ENGINE OPERATION

	 WARNING
When adding fuel:	
Turn engine off and let engine cool at least 2 minutes before removing gas cap. Fill fuel tank outdoors or in well-ventilated area. Fill tank to about 1 inch below lowest portion of neck to allow for fuel expansion. Keep gasoline away from sparks, open flames, pilot lights, heat, and other ignition sources.	
	 WARNING
When starting engine:	
Remove all external equipment/engine loads. Wait until spilled fuel is evaporated. Start engine outdoors. Pull cord slowly until resistance is felt, then pull rapidly. If engine floods, set choke to OPEN/RUN, place throttle in FAST and crank until engine starts.	
	 WARNING
When operating equipment:	
Do not tip engine or equipment at angle which causes gasoline to spill. Run engine outdoors. Do not run in enclosed area, even if doors or windows are open. Do not choke carburetor to stop engine.	

This Gasoline Motor Is Your Faithful Friend

Treat it as a Friend

1. This Briggs & Stratton Gasoline Motor embodies the most modern principles of gasoline motor construction. It is made of high-grade materials and is built by skilled craftsmen. Before it left the Briggs & Stratton factory it was put through many rigid tests, was carefully inspected and found to be in first class condition to give satisfactory service.

2. The less you tinker with the Briggs & Stratton Gasoline Motor the better service it will give you. This does not mean, however, that your motor does not require a certain amount of attention, for it is only a machine. It cannot tell you its wants but depends on you to give it the right kind of fuel, oil and care.

3. This operating manual gives you the following information:

	Pages
About the Guarantee.....	2 to 4
Starting the motor for the first time.....	6, 7
What to do when the motor will not start.....	7 to 10
Trouble Remedy Chart.....	11, 12
How your motor works.....	13, 14
Its construction and maintenance.....	15 to 22
How to order parts.....	23, 24
Parts illustrations	25 to 27
Parts and price lists.....	28 to 32
Index.....	Inside Front Cover
Motor specifications.....	Inside Back Cover

4. If this instruction book does not help you locate some specific trouble in your motor, then something too serious for you to correct has occurred. This means that it will be best to leave the motor alone and let an expert do the work. Consult your dealer first. He will help you, or will refer you to a nearby service station or advise you to return the motor to the factory.

Model and motor number must be given when writing or ordering parts

INDEX

	Paragraph Number	Page Number	Illustration Page Number
Air Cleaner.....	14	4	5
Carbon.....	56, 60	20, 21	
Carburetor.....	23, 24, 50 to 54	7, 8, 18, 19, 20	7, 19
Adjusting.....	53, 54	19, 20	19
Choke.....	20, 23, 24	7, 8	5, 7, 19
Hook-up.....	52	19	18
Cooling.....	38	14, 15	
Compression.....	30, 55 to 57	10, 20	
Connecting Rod.....	61	21	21
Cranking.....	20 to 22	7	5
Cylinder Head.....	60	21	
Cylinder.....	62	22	
Gasoline Line (Cleaning).....	28	10	7
Gasoline Tank.....	18	6	5
Guarantee.....	5 to 14	2, 3, 4	2
Governor.....	48, 49	18	18
Ignition.....	19, 22, 25, 26, 39 to 47	6, 7, 8, 15 to 18	8, 9, 15, 17
Contact Points.....	44	17	17
Fly Wheel.....	39, 41	15, 16	15
Fly Wheel Key.....	39, 41	15, 16	15
Spark Plug Cable.....	46	17	
Spark.....	25	8	8
Spark Plug.....	26, 42	8, 9, 16	5, 8, 9
Lubrication.....	11 to 13, 15 to 17, 36, 37	4, 6, 14	
Fill Oil Reservoir.....	12, 13, 17	4, 6	5
Oil to use.....	11, 15	4, 6	
When to add and change oil.....	12, 13, 17	4, 6	5
Parts			
How to order.....	23, 24		
Illustrations.....	25 to 27		25 to 27
Price List.....	28 to 32		
Piston.....	57, 58, 62	20, 22	
Priming Motor.....	27	9	
Speed Adjustment.....	48	18	
Starter.....	31, 64	10, 22	5
Starting Motor.....	20, 21, 22	7	
Stopping Motor.....	19, 48	6, 16	5
Timing.....	59	21	21
Trouble Chart.....		11, 12	
Valves.....	56	20	

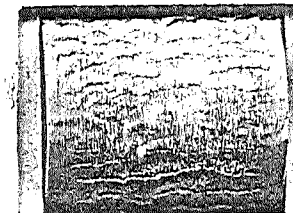
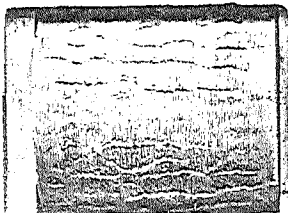

Have You Sent in the Registration Card Which Brings Your Guarantee Certificate?

5. You are entitled to a 90 day guarantee on your Model "S" Motor, so be sure that you get the Guarantee Certificate. It will only be sent to you after the Registration Card has been filled out

REGISTRATION CARD
No. 153
To Receive your MOTOR GUARANTEE CERTIFICATE
Fill out and mail this card at time of purchase.
Four print carefully in ink.Model No. _____ T. No. _____ A. No. _____
Date _____
Your Name _____
Mail Address _____
Town _____ State _____
Dealer Purchased From _____
Town _____ State _____
Machine No. _____
Motor Mounted on _____
Briggs & Stratton Corp., Milwaukee, Wis.

GUARANTEE CERTIFICATE
The Owner of this Briggs & Stratton Motor
Model No. _____ T. No. _____ A. No. _____
following guarantee:
Briggs & Stratton Corporation will replace for the original purchaser, upon examination at our factory at Milwaukee, Wisconsin, to be defective under normal use and service, on account of defects in material or workmanship, any part or parts submitted for replacement under this guarantee. This guarantee is void if the motor has been the subject of misuse, negligence or accident, or if the motor has been repaired or altered outside of our Milwaukee factory or authorized service stations in any way which, in our judgment, affects its condition or operation.
19_____
BRIGGS & STRATTON CORPORATION
W. Briggs, President

Registration Card and
Guarantee Certificate

and mailed in to the factory. The dealer from whom you bought your motor should do this for you, but if he did not do so, you should fill out the card and mail it at once.

6. By mailing in this card you not only make sure of getting your Guarantee Certificate but you also have your name and motor registered at the Briggs & Stratton factory and with the author-

2

Model and motor number must be given when writing or ordering parts

ized central service station in your territory so that, should you write regarding service or parts, your requirements will be taken care of promptly. If you did not get a Registration Card, ask your dealer for one or write to the Briggs & Stratton Factory.

What the Guarantee Includes

7. For 90 days from the date of purchase the Briggs & Stratton Corporation will replace for the original purchaser, free of charge, any part or parts found upon examination at our factory at Milwaukee, Wisconsin, to be defective under normal use and service, on account of defect in material or workmanship. All transportation charges on parts submitted for replacement under this guarantee must be paid by purchaser.

What the Guarantee DOES NOT Include

8. This guarantee does not cover the free replacement of parts, because of wear occasioned by use. It does not cover the labor cost of replacing parts, neither is it effective if the motor has been the subject of misuse, negligence or accidents, nor if the motor has been repaired or altered outside of our Milwaukee factory or authorized service stations in any way which, in our judgment, affects its condition or operation.

Keep Your Motor Clean

9. It is important to keep your motor clean both inside and outside. This extra care will repay you many times in better service.

10. See that no dirt or water enters motor when filling with oil or gasoline. As a precautionary measure always wipe off the gasoline cap and oil filler plug as well as around them before refilling.

3

Model and motor number must be given when writing or ordering parts

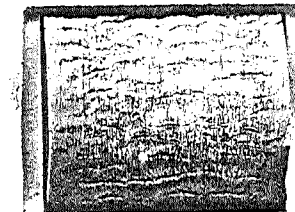
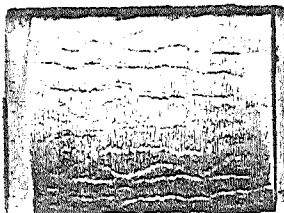

Failure to Follow these Instructions Voids Your Guarantee

Use the Right Kind of Oil

11. We recommend the use of GARGOYLE MOBILOIL "ARCTIC" or other high grade oil of similar characteristics having low carbon residue and a body not heavier than S. A. E. No. 20. A kind of heavy oil which might be satisfactory in a tractor or for lubricating farm machinery must NOT be used.

Put Oil in Every Day

12. A motor which is run without oil will be ruined within a few minutes. To avoid the possibility of such an occurrence, and the resulting expense this would cause, always fill the oil reservoir to the level of the filler plug opening every day the motor is used.

Change Oil At Least Once for Each Fifty Hours Motor Runs

13. After each fifty hours of operation, the old oil must be completely drained from crankcase by removing oil filler plug from elbow, and turning elbow out half a turn to bring opening down, and then tip motor toward the filler elbow. (See figure 1 on page 5). Drain out the oil when the motor is hot, because hot oil drains out quickly and thoroughly. Then turn elbow to bring opening on top and refill with fresh oil. We do not recommend flushing out with kerosene. In the normal running of any motor small particles of metal from the cylinder walls, pistons and bearings will gradually work into the oil. Dust particles from the air also get into the oil. Sludge forms a gummy mass which clogs up the oil passages. If oil is not changed regularly, these foreign particles cause increased friction and a grinding action which shortens the life of the motor.

Air Cleaner

14. Operating an "S" motor in a dusty or dirty atmosphere without using an air cleaner voids your guarantee, because no motor can stand up under the grinding action that takes place when dirt and sand particles are drawn into the motor through the carburetor. It is also important to clean the air cleaner every day by removing it and washing in kerosene, then dipping it in oil to make it efficient.

4

Model and motor number must be given when writing or ordering parts

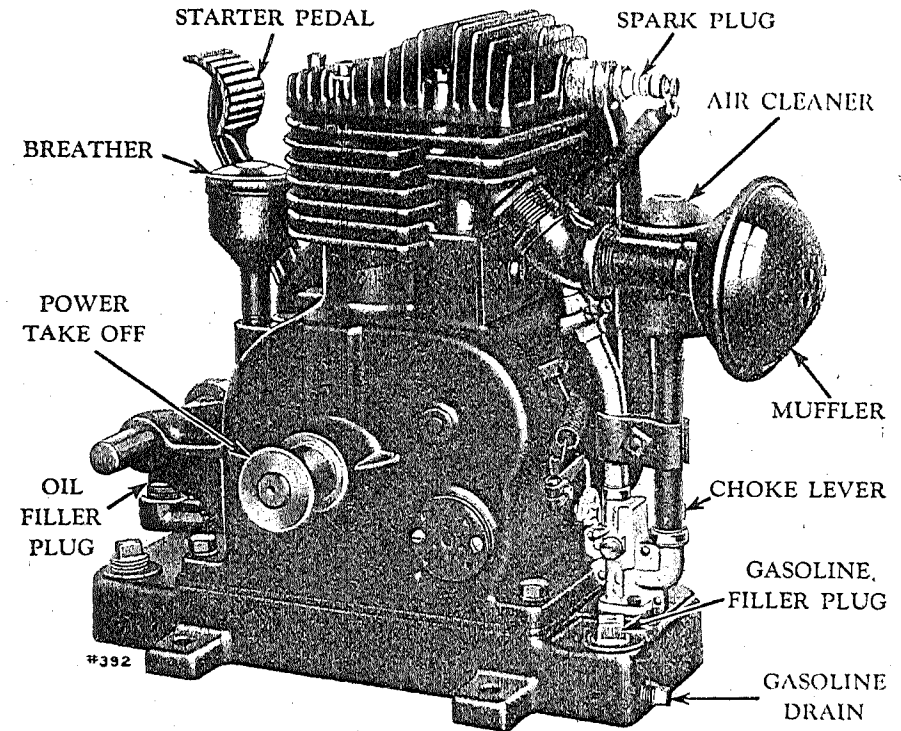
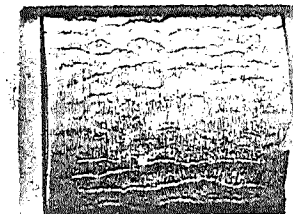
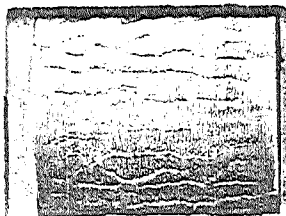

Fig. 1.
Model "S" Motor

5

Model and motor number must be given when writing or ordering parts



Starting the Motor for the First Time

Use the Right Kind of Oil

15. Be sure there is oil in the motor before you attempt to start it, and make sure that you use the right kind of oil. A comparatively light oil must be used. WE RECOMMEND GARGOYLE MOBILOIL "ARCTIC" FOR YEAR AROUND USE.

Do Not Mix Oil with the Gasoline

16. Do not mix oil with the gasoline. It is not necessary in this 4-cycle motor for it is provided with a complete lubrication system which includes an oil pump and an oil trough into which the connecting rod dips. This system provides adequate lubrication for all parts of the motor. The oil is also effective in cooling the motor by carrying heat away from the piston and cylinder walls.

Fill the Oil Reservoir

17. The oil filler plug is shown in the motor illustration, (Figure 1 on page 5). With motor level remove filler plug and pour in oil until it rises to the level of the filler plug opening. The capacity of the oil reservoir is about 1 pint.

Fill the Gasoline Tank

18. The gasoline tank is filled by removing the red plug in the base. The capacity is 2 pints. High test gasoline is recommended and insures easy starting, particularly in cold weather. Be sure that the small vent hole in the gasoline tank plug is not clogged up, for air must enter the tank to allow the gasoline to flow to the carburetor. Test by running wire through hole in plug.

Spark

19. A spark will be supplied to the spark plug as soon as you crank the motor, the source of ignition being a magneto built into the flywheel. When starting motor it is not necessary to turn on any switch in order to turn on the ignition. To stop motor, however, press on the red stop button until the motor stops turning.

6

Model and motor number must be given when writing or ordering parts

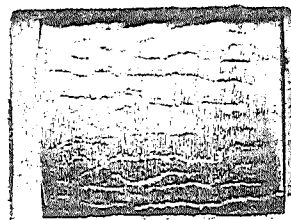

Cranking

20. First turn the choke lever, located on air cleaner tube, into horizontal position to choke carburetor (See Figures 1 and 2). Closing the choke shutter chokes off air going to the carburetor the same as the choke on an automobile.

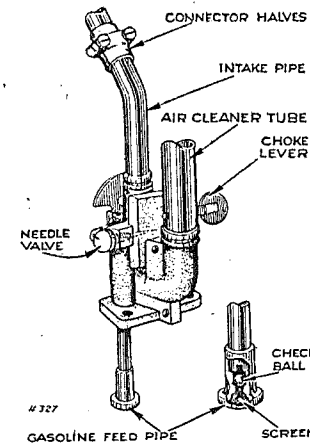

Fig. 2.
Carburetor

21. Step down on starter pedal giving it a fast kick and repeat before motor stops turning, pumping quickly until the motor fires. Immediately after motor starts, gradually open choke shutter by slowly turning choke lever into vertical position until motor runs smoothly with choke wide open. If motor is cold, it may slow down or sputter. In this case close choke again for a few seconds. If the motor stops, you have probably choked it too much or not enough. You

will soon learn to judge the correct operation of the choke lever so that the motor can be quickly started and kept running without difficulty.

22. You should also remember that very slow cranking may not start the motor because of the fact that the spark is produced by the magneto which requires a certain amount of speed before it produces a spark at the plug.

What To Do When Motor Will Not Start

The Correct Use of the Choke

23. With gasoline vapor in the motor, this vapor compressed and a spark at the spark plug, there is not much question about starting the motor. Of course it sometimes happens that the gasoline mixture is not right and will not fire properly. This is perhaps the most common cause of failure to start, particularly in a new motor with which you are not thoroughly familiar.

7

Model and motor number must be given when writing or ordering parts

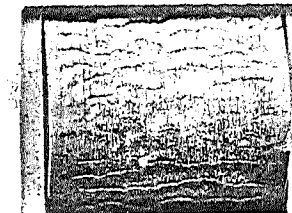

24. The correct carburetor setting is one which gives a good operating mixture when the motor is hot. Because gasoline does not vaporize so well when cold, it is necessary to choke the carburetor in order to cut down the amount of air and give a mixture which is approximately correct for starting. Until you become familiar with your motor, however, you may make the mistake of not choking the motor enough or you may choke it too much and get a lot of raw gasoline in the motor. If you have operated the choke while cranking the motor three or four times, try cranking two or three times with the choke wide open. Then, if the trouble was due to choking too much you will find that the motor will start as the excess gasoline is driven out through the exhaust pipe.

Checking the Spark

25. To be sure that you have a spark at the spark plug, you can remove the wire from the plug and hold it within $\frac{1}{8}$ " of any metal part of the motor (See Fig. 3). Keep the hand back on the insulated part of the wire so that you will not get a shock. Then crank the motor and see if a spark will jump this $\frac{1}{8}$ " gap. If it does, you will know that the spark is amply strong to jump the small gap at the spark plug when in the motor under compression. This test is

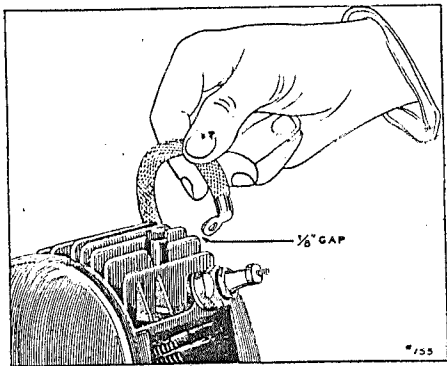

Fig. 3.
Checking Spark

evidence that your entire ignition system is working satisfactorily. If there is no spark, check the various items on the Trouble Remedy Chart, pages 11 and 12, or see your local dealer or nearest Briggs & Stratton service station.

Checking Spark Plug

26. It sometimes happens that a spark plug porcelain is

8

Model and motor number must be given when writing or ordering parts

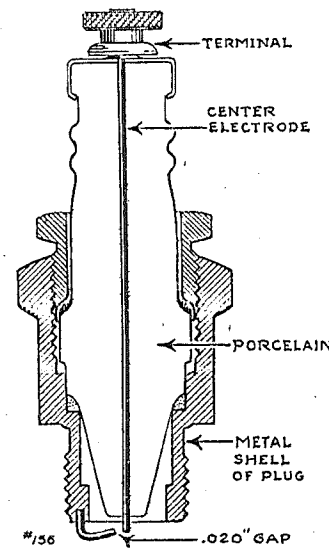

Fig. 4.
Spark Plug

cracked or broken so that the spark jumps from the center electrode through to the shell of the spark plug and does not jump at the gap inside of the cylinder (see Fig. 4). This, of course, prevents the motor from firing. The simplest way to check a spark plug is to try a new one and you will find it advisable to have a spare spark plug on hand for testing. If the motor starts with the new plug, then you know that the old one is at fault and should be discarded. The gap at the spark plug should be somewhat less than $\frac{1}{32}$ " (.020" to be exact). Replacement plug must have same characteristics as No. 7 Champion 18 M.M. Thread, $1\frac{1}{2}$ M.M. Pitch.

Priming the Motor

27. On the suction stroke, the motor draws gasoline up through the carburetor, mixes it with air, and feeds a combustible mixture to the cylinder. However, if the magneto produces a good spark and a good spark plug (set with a gap of .020") is in the cylinder and still you cannot start the motor, it is advisable to remove the spark plug and pour in about a half teaspoonful of gasoline. This should run the motor three or four revolutions to show you that it is in operating condition, even if there is no gasoline in the tank and the carburetor is not functioning. Difficulty in the carburetor, however, is extremely unlikely, for the new motor you have was thoroughly tested under its own power and was operating perfectly before it was shipped from the factory.

9

Model and motor number must be given when writing or ordering parts

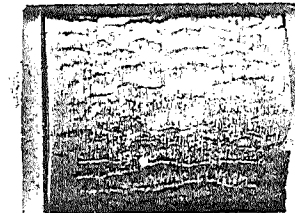
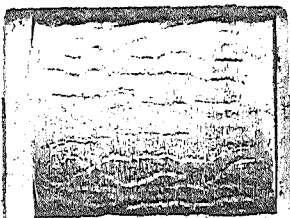

Cleaning the Gasoline Line

28. If the motor will run after the cylinder has been primed with gasoline, but will not run otherwise, it is possible that the gas pipe from the base to the carburetor is stopped up. Disconnect the intake pipe connector halves from the intake pipes (see figure 2) and unscrew the carburetor from the base. Remove the gasoline feed pipe from the carburetor noting particularly the length of the pipe before loosening the lock nut so that the pipe can be properly assembled back to the carburetor. Wash out the screen in gasoline and blow thru' the screen end of the pipe. The check ball as shown in figure 2 prevents air from passing thru' when blown from the opposite end.

Adjusting Carburetor

29. The carburetor is properly adjusted at the factory but if you think the adjustment has been tampered with you can adjust it over again in accordance with the instructions given on page 18.

Testing Compression

30. The motor to run properly must have good compression. You can test this by turning the motor over by hand to make sure there is one point in its rotation where it turns harder than it does at other points. This is due to the upward motion of the piston compressing the fuel mixture. If the flywheel is released, it should rock back and should do this two or three times before the compression all leaks away. If there is no compression, read paragraphs 55 to 57 and 62.

Starter

31. To crank the motor successfully, it is necessary that after depressing the starter pedal, it should come up quickly with your foot, so that the motor can be spun or pumped. Should starter pedal stay down or come up slowly, put a little kerosene on the large return lever spring to loosen it.

10

Model and motor number must be given when writing or ordering parts

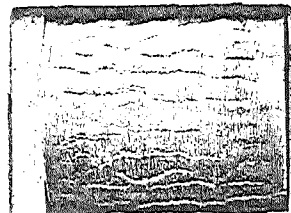

Trouble Remedy Chart

Motor Will Not Start

A--Fuel

	See Paragraph Number
1. Gasoline tank supply.....	18
2. Improper use of choke.....	23-24
3. Gasoline does not reach carburetor.....	28-29
4. Improper carburetor adjustment.....	52-54
5. Carburetor Hook-up	52
6. Water in the gasoline.....	10
7. Water frozen in carburetor or gasoline pipe.....	10-28 (Extremely cold weather only)

B--Spark

8. Plug not functioning properly.....	25-26-42
9. Ignition cable grounded, oil soaked or wet.....	46
10. Magneto not delivering proper spark.....	25-35-39 to 47
a. Contact points are not properly adjusted.....	44
b. Contact points oily or dirty.....	44
c. Magneto plate and coil soaked with water or oil.....	44
d. Stop button bent, stuck, wet or dirty.....	43
e. Safety Woodruff key sheared off.....	34-39-41

Lack of Power

11. Poor compression	30-55 to 57-60
12. Poor spark	25-34-39 to 47
13. Improper carburetor adjustment	52 to 54
14. Exhaust pipe or muffler clogged.....	63
15. Improper valve clearance.....	56
16. Machine being operated is overloaded.....	65
17. Machine being operated needs oiling.....	65
18. Overheated, (See "Overheats" Page 12.)	

11

Model and motor number must be given when writing or ordering parts

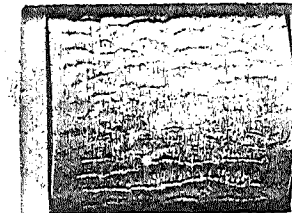

Trouble Remedy Chart

Overheats

	See Paragraph Number
19. Oil supply low	11 to 17
20. Oil needs changing—is too thick to cool engine properly.....	12-13-38
21. Carbon in cylinder head.....	60
22. Poor spark	25-34-39 to 47
23. Machine being driven is overloaded.....	65
24. Machine being driven needs oiling.....	65

Stops

25. Gas supply shut off.....	18-28
26. Intermittent spark failure.....	25-34-39 to 47
27. Overheated	
28. Flywheel key sheared—loose flywheel.....	34-39-41

Knocks

29. Carbon in cylinder head.....	60
30. Loose connecting rod	61
31. Worn main bearings	4-36
32. Loose flywheel	34-39-41
33. Lack of oil.....	11 to 17
34. Defect in connection with machine being driven	65

Starter

35. Starter pedal sticks	31
36. Starter pedal slips on shaft.....	64

12

Model and motor number must be given when writing or ordering parts

How Your Model "S" Motor Works

The 4-Cycle Principle

32. The reliability, economy and ease of starting which characterize your Briggs & Stratton motor are due in part to the fact that it is designed on the 4-cycle principle which is the basis of the design

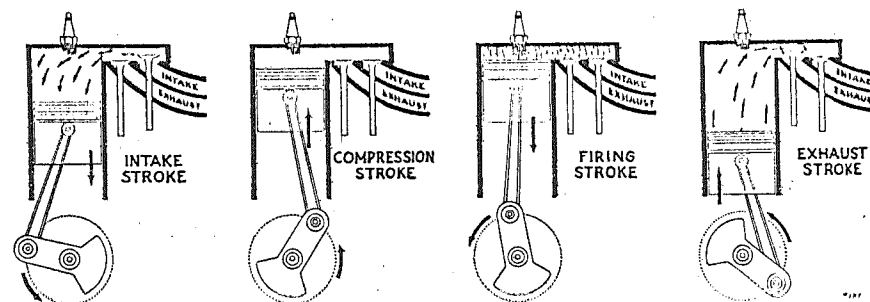

Fig. 5.
4-Cycle Principle

of all automobile motors. In the common term "4-Cycle Motor" we leave out the word "Stroke" for this description as applied to a motor really means that there are four strokes to one cycle, a cycle being a series or round of events.

33. In our 4-cycle motor the events are indicated in Fig. 5. On the intake stroke (illustration at the left), we have the piston going down, producing a vacuum in the cylinder, thereby drawing fuel up through the carburetor so that the space above the piston becomes filled with combustible gas. During this stroke the intake valve is open. In the next illustration we find the piston coming up on the compression stroke with both valves closed. At the top of the compression stroke a spark occurs at the spark plug, firing the gas. This produces an explosion above the piston which forces it down on the firing stroke. Both valves are closed on the firing stroke. On the next upstroke of the piston, the exhaust stroke, with the exhaust valve open, the burned gas is driven out.

13

Model and motor number must be given when writing or ordering parts

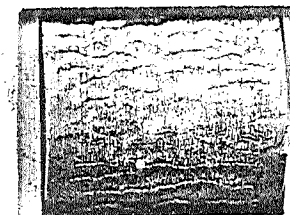

The Ignition

34. The spark which fires the gas in your motor is produced by a magneto built in the flywheel. This is a simple self contained system which is very reliable. It also does away with batteries and wiring with the exception of the high tension wire to the spark plug and the single wire which comes out to the red stop button. The magneto contains a coil, a condenser, a pair of contact points and a rotating magnet cast into the flywheel. This rotating magnet is properly timed with relation to the magneto by keying the flywheel to the crankshaft.

The Carburetor

35. The carburetor is a device for properly mixing gasoline vapor with air and feeding it in correct amounts to the motor.

The Lubrication

36. The lubrication of your Model "S" Motor is taken care of by a pump which is operated from an eccentric on the camshaft. This pump keeps a trough, into which the connecting rod dips, constantly full of oil. The dipping of the connecting rod then throws oil to all moving parts of the motor. Oil, which is splashed to the main bearings, is in no danger of leaking out of the motor. Return ducts are provided in which check valves are used. The suction in the crankcase draws oil back into the oil reservoir but pressure in the crankcase cannot reverse the action and force oil out again. Consequently, the motor stays clean and the oil supply is efficiently used.

37. Note that in the design of your Model "S" Motor there are no external parts which require separate oiling.

The Cooling

38. The cylinder is cooled by air as are the cylinders of modern airplane engines. The rotation of the flywheel blows air all around the cylinder which is covered with thin metal fins to help carry heat away from the cylinder walls. As previously mentioned, the oil also assists in cooling. In cooling the motor, the lighter portions

14

Model and motor number must be given when writing or ordering parts

of oil are gradually driven off and unless frequently changed, the oil which remains becomes too heavy to lubricate or cool the motor effectively. See Paragraphs No. 11 to 17, Pages 4 and 5.

CONSTRUCTION AND MAINTENANCE

Ignition System

39. Removing the Flywheel and Magneto. To inspect the magneto or check up on the contact point setting, it is necessary to remove the flywheel.

This is done by unscrewing the nut which holds it in place. A right-hand thread is used, so the nut should be turned to the left. It can be started by tapping the wrench handle with a hammer. Then place a block of wood against the end of the crankshaft and strike it to loosen the flywheel. The magneto is removed by taking out three screws.

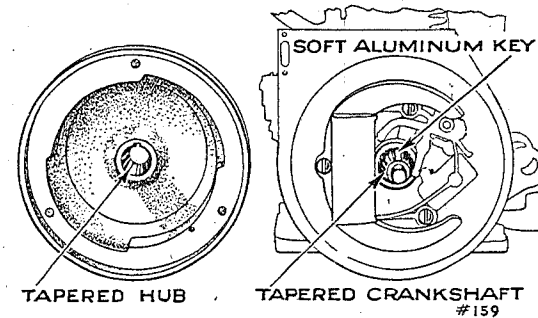

Fig. 6.
Magneto Flywheel and Crankshaft Taper

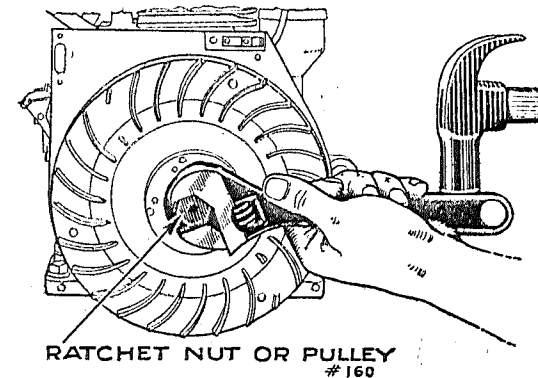
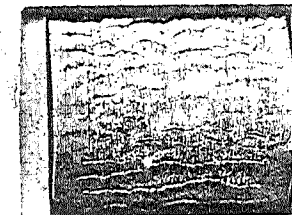
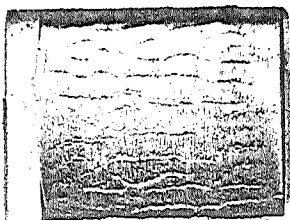

Fig. 7.
Tightening Flywheel

15

Model and motor number must be given when writing or ordering parts



41. **Replacing the flywheel.** When completing any necessary work, replace the flywheel, being sure to use the soft Woodruff key supplied. The key is only for the purpose of locating the flywheel on the crankshaft in the correct position so that the magneto will be correctly timed. The flywheel is driven, however, by being a tight taper fit on the taper of the crankshaft. This taper is shown in Fig. 6.) In case the flywheel should come loose, the soft Woodruff key is designed to shear off so that no damage will be done. Therefore, a steel key should never be used. After the flywheel is in place, has been located with the key and nut or pulley has been screwed up, this nut or pulley should be made **VERY TIGHT**. This can be done as shown in Fig. 7 by striking the wrench handle or bar with a hammer.

42. **Spark Plug.** A sectional view of the spark plug is shown in Fig. 4 on page 9. The purpose of the porcelain is to prevent the spark from jumping anywhere except at the gap in the cylinder. If the porcelain is cracked or broken, however, the spark may jump through to the shell of the spark plug. This will prevent the motor firing. Water on the outside of the spark plug may permit the high voltage spark current to leak over the surface of the porcelain. Carbon deposits on the porcelain inside of the cylinder will do the same thing. The spark plug should, therefore, be removed to see that the porcelain is not heavily coated with carbon. It can be cleaned by taking the plug apart and washing off the carbon with gasoline or cleaning with some kitchen scouring powder. When the plug has been put together again, the gap should be set at .020".

43. **Stop Button.** See that the stop button is not bent or held down by the blower case so that it makes contact continuously. To check this it may be necessary to remove the blower case. See that the button is not shorted with dirt, water or oil. Also check the small wire which runs down to the magneto to see that it is not grounded.

16

Model and motor number must be given when writing or ordering parts

44. **Contact Points.** While the magneto plate is still on the motor, you can turn the crankshaft by hand and see if the contact points open and close properly. They should have a gap of .020". The contact points surface should be clean and the faces of the points square so that when they come together they make good electrical

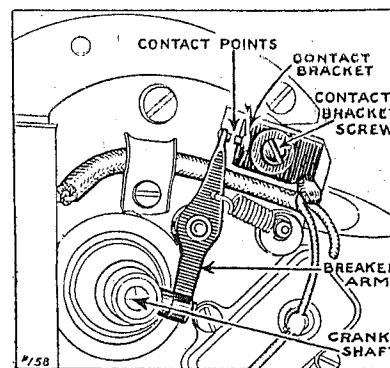

Fig. 8.
Magneto Parts

contact. If points become badly burned or pitted it may be necessary to replace them with new ones. When checking up the contact points be sure that all parts of the magneto are clean and free from grease, water and dirt. Small metal particles, in particular, will cause trouble and prevent the magneto from firing. The various parts can be washed off with gasoline on a clean rag. Avoid getting gasoline on the coil. Dry off the magneto with another clean rag before putting it in service again.

45. Inspect the soldered terminal on the condenser and the contact bracket.

46. **Spark Plug Cable.** Check the spark plug cable to see that the insulation is not broken, soaked with oil or water, grounding it, especially at some point where it touches the motor or is very near to the motor. It may be necessary to remove the flywheel and magneto in order to check this cable all the way to the magneto coil. Under no circumstances should the cable be soldered to the coil as heat damages the coil insulation. A twisted connection is sufficient as the cable is held securely by a clip. When checking the cable, also check the ground wire which goes up to the red stop button to see that the insulation is not broken so that the wire rubs on some metal part of the motor.

17

Model and motor number must be given when writing or ordering parts

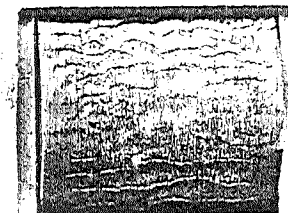
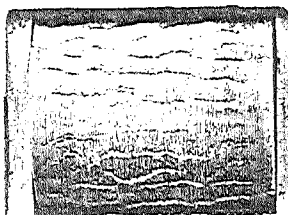

47. **Condenser, Coil and Magnet.** If you have not located the trouble up to this point, it is probably in the condenser, the coil or the magnet. Under these circumstances, you should see your dealer or send in the complete magneto with flywheel to the Briggs & Stratton factory, or to the nearest Briggs & Stratton service station.

Governor

48. **Speed Adjustment.** Normal motor speed 1750 R. P. M. To change motor speed, change tension of throttle spring by moving throttle spring clip. More tension on throttle spring increases speed, less tension reduces speed. (See figure 9.)

49. **Resetting Governor Lever.** If governor lever has been loosened on its' shaft it is reset as follows: (See Fig. 9). With carburetor

attached to motor and hooked up to governor lever with throttle link, loosen clamp screw which holds governor lever on its shaft. Hold upper end of governor lever firmly to the right with throttle plate against its stop in carburetor body. Holding governor lever in this position, turn governor shaft hard to the right or clockwise, with pliers, until you feel it strike a stop inside of crankcase. Tighten clamp screw firmly, being sure that neither the governor shaft or governor lever moves while doing so.

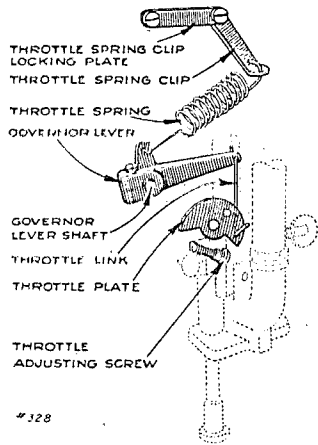

Fig. 9.

Carburetor Hookup

Carburetor

50. The carburetor used on your Model "S" Motor is shown in Fig. 9 and Fig. 10. As received from the factory it is properly adjusted. However if it has been tampered with, it can be adjusted over again as described below.

51. **Removing and Replacing Carburetor.** Remove air cleaner tube clamps and pull out air cleaner tube. Unscrew the connector halves from the intake pipe. Remove two small screws which hold carburetor to the base. Pull up the carburetor and away from the motor until throttle link slips out of the governor lever and then pull carburetor completely out of the base. To replace the carburetor reverse the operations as performed above.

52. **Hook-up.** The throttle link must have the hook end hooked thru' the small hole in the lower right end of the throttle plate as

shown in (Figure 9), and the other end hooked thru' the small hole in the long end of the governor lever. The throttle spring clip is held to the crankcase under the throttle spring clip locking plate. The throttle spring must have the coiled end hooked into the throttle spring clip and the other end hooked into the eye of the cotter pin in the governor lever:

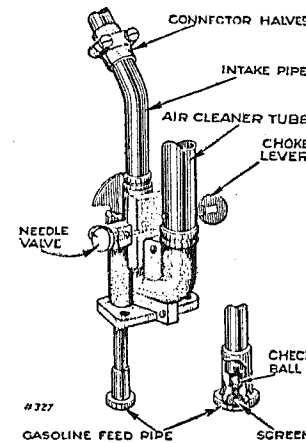
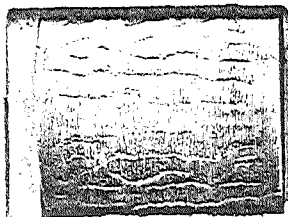

Fig. 10.
Carburetor

53. **To Adjust Carburetor.** Completely close needle valve by turning to right or clockwise with fingers as far as possible. From closed position open needle valve by turning to left or counterclockwise about one to one and a half turns, lining up setting

mark notched in the face of needle valve wheel with the small pin directly on the side of it. (See illustration No. 10.) After the motor has been started, warmed up and running with the choke wide open, turn needle valve a notch at a time in either direction, to find final needle valve setting point at which motor operates most smoothly. This final setting point should be with the needle valve turned to



the right, or lean, as far as possible, but so motor will still run smoothly with full load. When this final needle valve setting has been determined, do not change it again. This setting will take care of future starting and running.

54. **Idling Adjustment.** The idling speed can be adjusted by the throttle adjusting screw shown in (Figure 9). By screwing the adjusting screw clockwise will increase the idling speed, counter-clockwise will decrease the idling speed.

Compression

55. Compression in the motor is obtained by having valves which seat properly, gaskets which are tight, a spark plug which does not leak, and piston and piston rings which are properly fitted.

56. **Valves.** Valves are properly fitted when the motor comes from the factory. Valve tappet clearance should be measured with motor cold. Clearance on exhaust valve .020 of an inch, on intake valve .010 of an inch. Adjustment of valves is made by grinding the ends of valve stems. When grinding, care must be taken to keep end of valve stem square to valve stem proper. It should seldom be necessary to remove carbon and grind in valves if correct oil and fuel are used.

57. **Piston.** The piston in the Model "S" Motor is made of a special aluminum alloy which is very light in weight. This material permits your motor to develop maximum power at high speed, with minimum vibration. The standard clearance between the piston and cylinder wall is .0055" to .007". The piston rings, when fitted into the cylinder, should have from .007" to .012" gap.

58. **Piston Pin.** The piston pin is a free fit in one side of the piston and a tight fit in the other. To remove this pin without special equipment, it is advisable to heat the piston in boiling water. Cut a wooden pin a little smaller than the size of the piston pin and use this and a hammer to drive the pin out. You should of course drive the pin out while the piston is still hot. The piston should also be heated up in order to enable you to easily re-

Model and motor number must be given when writing or ordering parts

place the pin. The heating facilitates the work— use of the rapid expansion of aluminum when heated. This also accounts for the clearance of .0055" to .007" which is used in fitting the piston to the cylinder.

Timing

59. The timing of the valves is taken care of by the meshing of the cam shaft gear with the one on the crankshaft. These gears are properly meshed when the punch mark on the cam shaft gear is in line with the chisel mark on the crankshaft. (See Figure 11).

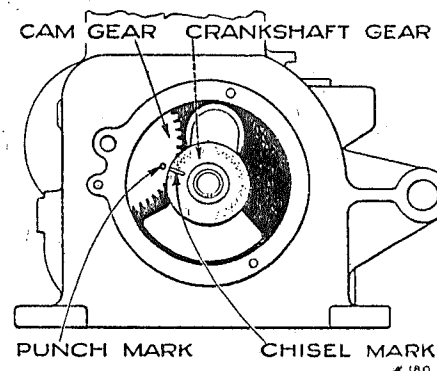

Fig. 11.
Timing

Cylinder Head

60. The cylinder head is held on with six cap screws. When the cylinder head has been removed for the purpose of cleaning carbon or grinding valves, care should be used in replacing it. Use a new gasket if possible. Otherwise, clean the old one and coat both sides with cup grease. We do not recommend the use of shellac on cylinder head gasket. In tightening the six cap screws, tighten them a little at a time so that the cylinder head is pulled down evenly rather than all at one side first.

Connecting Rod

61. **Connecting Rod.** The connecting rod is also made of a special aluminum alloy which combines strength with light weight. The lower bearing is of conventional type used with splash lubrication and should it become loose, can be refitted. When assembling connecting rod to crankshaft, the assembling marks must both be on the same side of the rod and the oil hole and groove in the dipper must be toward the carburetor end of the motor. (See Figure 12).

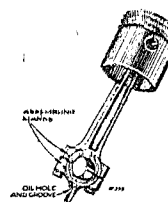
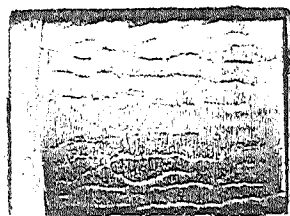

Fig. 12.
Connecting Rod

Model and motor number must be given when writing or ordering parts



Worn or Scored Piston, Rings or Cylinder

62. This will only occur after long use of the motor, unless it was run without oil, oil not the quality and grade recommended, oil not changed regularly, or run with continuous overload. When diameter of cylinder at center is .005" or more larger than diameter of cylinder at the ends (top and bottom), cylinders should be re-ground to necessary standard oversize, which is .010", .020", or .030" as required and fitted with the corresponding standard oversize piston and rings. An authorized Briggs & Stratton Service Station should make the repairs.

Exhaust Pipe and Muffler

63. After long periods of service it is possible that the muffler will become clogged to the point where it will affect the motor's power. To check the muffler you can unscrew it from the motor, and run water into the open end of the muffler. If full streams of water come out of the small holes at the end of the muffler, you will know that it is not clogged up. If the water runs through very slowly, however, the muffler is probably clogged and should be replaced with a new one.

Starter

64. When replacing starter lever assembly, it is important that tension be put on the lever return spring and then the lever pushed in far enough to line the chain up with the ratchet, and then tighten the set collar in its proper place. To replace pedal, determine its desired angular position first, and then push pedal on end of shaft and tighten securely the cap screw with a heavy wrench. The fine grooves on the end of the shaft and inside the hole in the pedal, permit the pedal to be set at any desired angle and also prevent the pedal from slipping on the shaft.

Effect of Load on Motor Operation

65. We have covered practically every condition that could possibly affect the operation of your Model "S" Motor. Of necessity, however we have not been able to touch on conditions in the machine which the motor is driving. It is just as important to check up on

22

Model and motor number must be given when writing or ordering parts

the machine as it is to take care of the motor. The machine should not be overloaded, should be lubricated regularly and should be inspected to see that the belt or chain drive is in good condition.

Important

Follow these instructions when ordering parts or when writing for Information.

A. Before ordering parts

Check up with your dealer if it is possible to do so, in regard to parts you believe are needed. He will assist you on any service that is necessary and will help you select the correct parts for your motor.

B. Give model letters and number of motor

This information is most important as we make many gasoline motors in various types and sizes. You will find the model letters and motor number on the brass plate at the side of the motor.

C. Give name and catalog number of parts wanted

You will find part numbers and description in section following parts illustrations. (Do not use numbers cast on parts.)

D. Send remittance with order to cover parts plus postage

Prices of parts are given in the pages which follow. Add what you think will be sufficient for postage and send postal or express money order for this amount. Do not send currency in a letter. It is not safe. By following these suggestions carefully you will avoid delay and added expense usually connected with C. O. D. shipments.

E. Be sure your name and address are given plainly and correctly Print name and address. Do not abbreviate name of town or state.

F. Always specify on the order how shipment to you is to be made.

G. Address your order or letter to Briggs & Stratton Corporation, Milwaukee, Wisconsin or Authorized Service Station, attention of Service Department.

23

Model and motor number must be given when writing or ordering parts

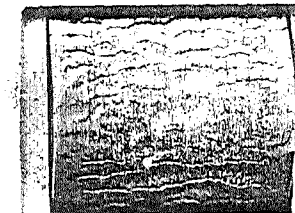
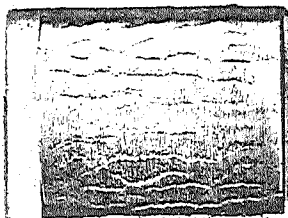

II. After you have made out order, check back to see that you have followed these instructions accurately.

This will save time and money for you and assist in giving prompt and efficient service.

I. When returning Motor or Parts to factory or Service Station.

If your motor or parts are returned for any reason, be sure your name and address are on both the inside and outside of the package.

Model and motor number must always be given from which parts were taken, to insure prompt and accurate service.

You should also write, explaining fully the reason for the return and exactly what is to be done with it.

All return shipments must be prepaid, or they will not be accepted.

PRICES

NOTE—All prices in this book are subject to change without notice. In case of change in price, orders will be filled at current prices. All prices shown are F. O. B. our factory in Milwaukee, Wis. Prices higher in Canada.

Model and motor number must be given when writing or ordering parts

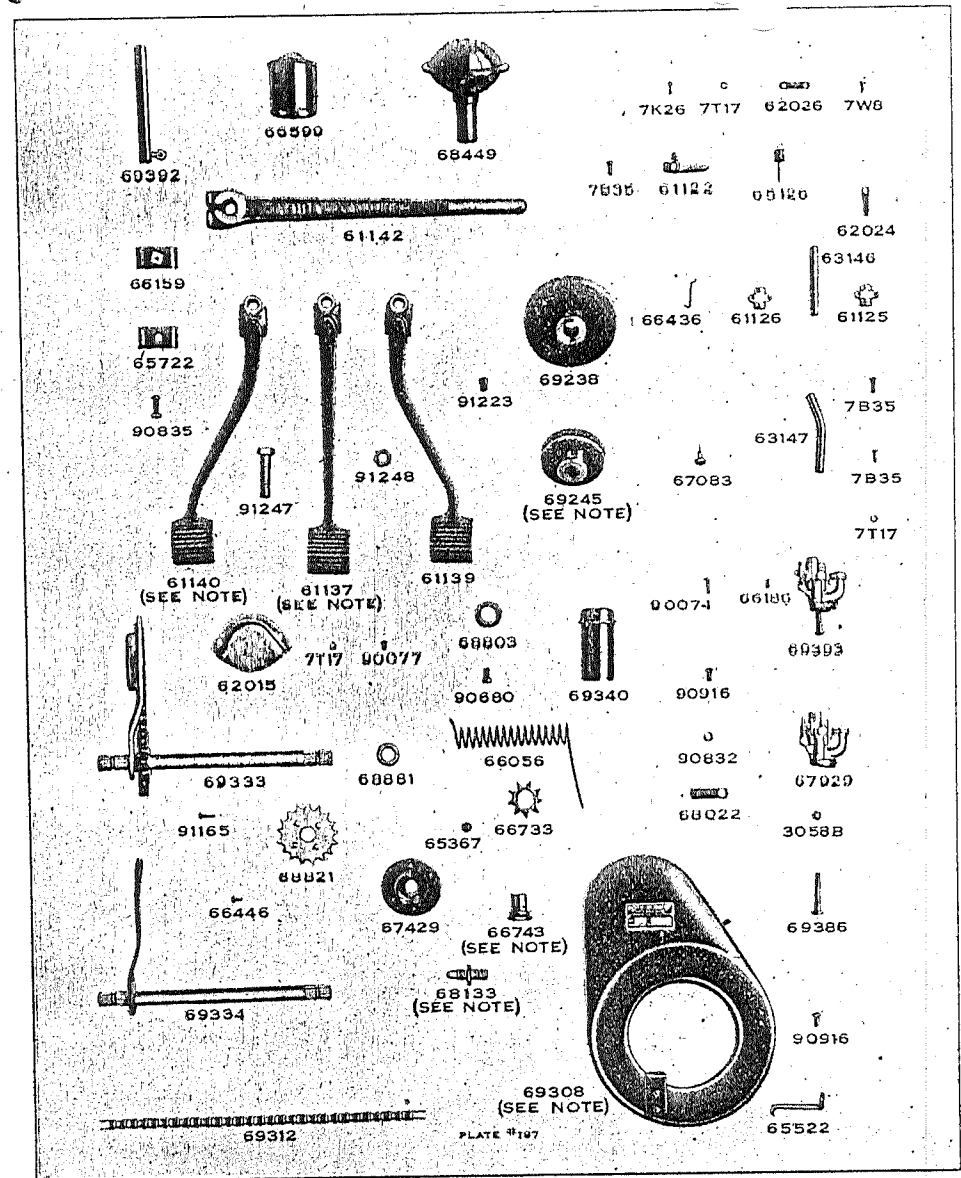

Model and motor number must be given when writing or ordering parts

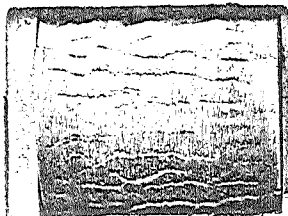

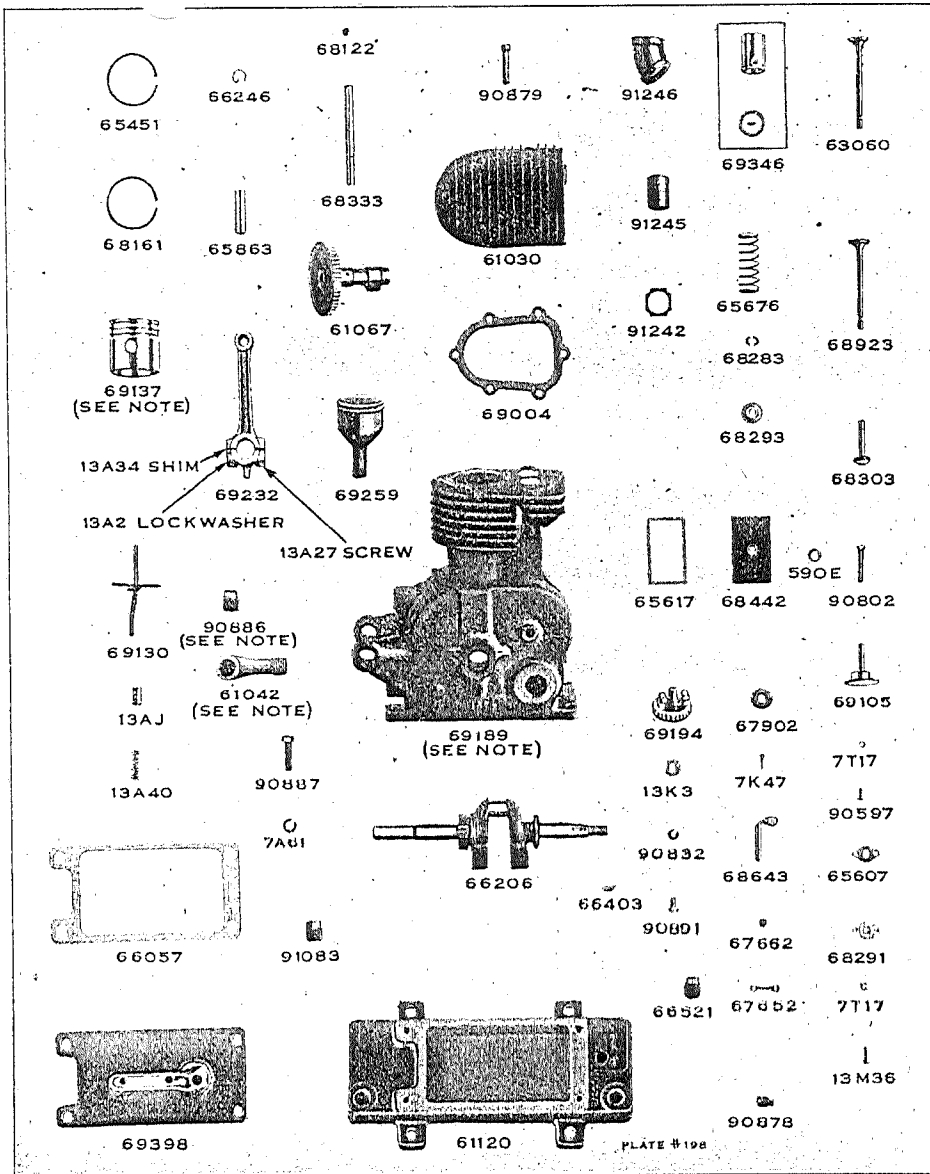

26

Model and motor number must be given when writing or ordering parts

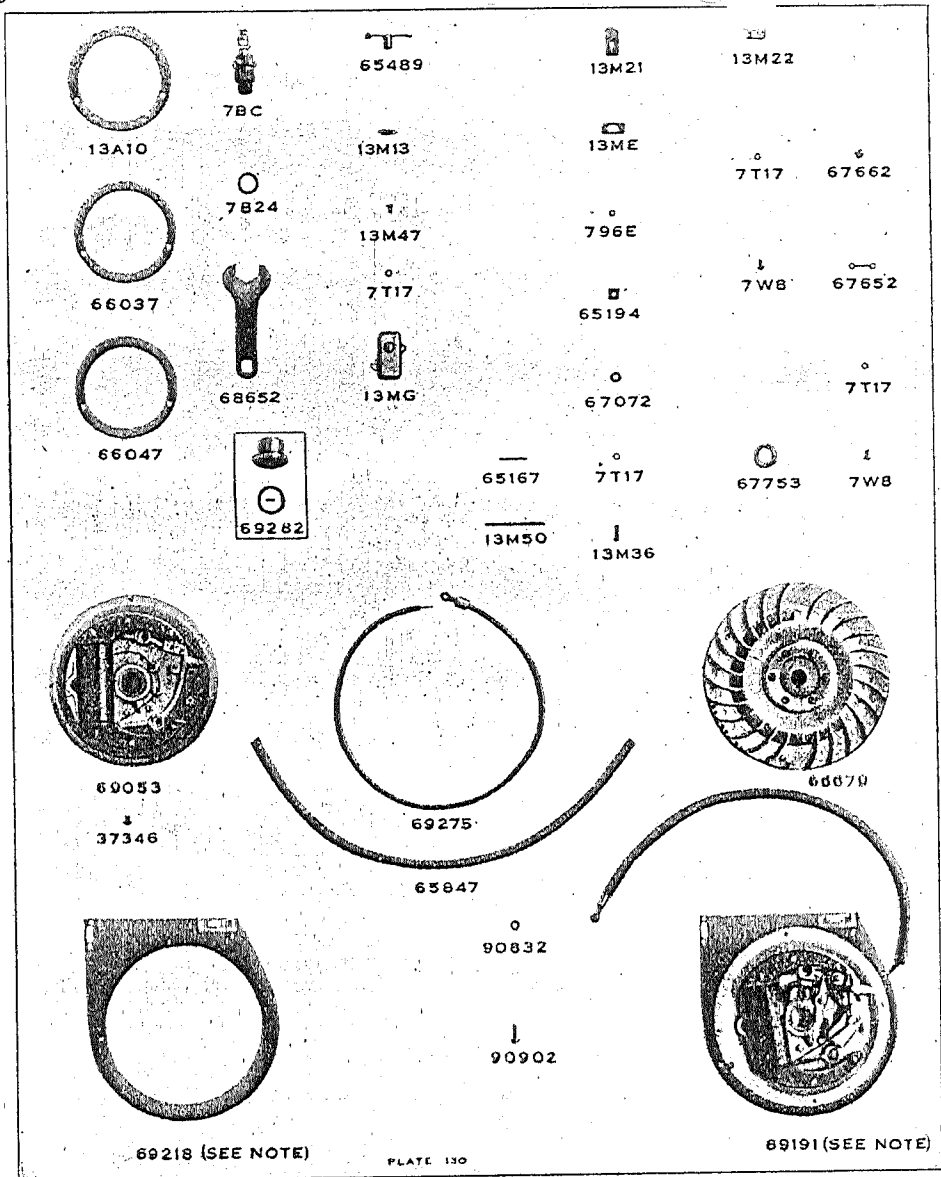

27

Model and motor number must be given when writing or ordering parts

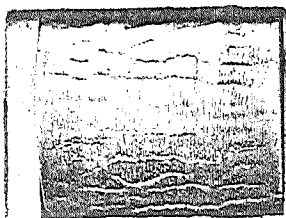

PARTS AND PRICE LIST

Part No.	Name	Where Used	Price Each
7A61	Lockwasher	Cylinder to base	\$.01
7BC	Spark Plug with No. 7B24 gasket		.75
7B24	Gasket	Spark plug	.05
7B35	Machine Screw	1—Governor lever	.01
		2—Intake pipe connectors	
		2—Carburetor mounting	
7K26	Cotter Pin	Governor lever	.01
7K47	Cotter Pin	Governor crank	.01
7T17	Lockwasher	2—Governor flange	.01
		2—Carburetor mounting	
		2—Throttle clip plate	
		2—Oil valve in crankcase	
		2—Oil valve—Magneto	
		1—Cable clamp—Magneto	
		2—Condenser—Magneto	
		1—Contact bracket—Magneto	
		2—Ratchet guard	
*7W8	Machine screw	2—Throttle spring clip	.05
		1—Cable clamp—Magneto	
	Note—Replaced by No. 13M36 screw for oil valve on magneto cover.		
13AJ	Oil pump plunger assembly	Oil pump	.20
13A2	Lockwasher	Connecting rod	.01
13A10	Gasket, .015" thick	Magneto	.05
13A27	Cap screw	Connecting rod	.05
13A34	Shim	Connecting rod	.05
13A40	Spring	Oil pump plunger	.10
13K3	Washer	To retain governor gear	.05
13ME	Contact bracket assembly	Magneto	.50
13MG	Condenser	Magneto	1.50
13M13	Spring	Breaker Arm	.05
13M21	Shim	Contact bracket—Magneto	.05
13M22	Clamp	Ignition cable	.95
13M36	Machine screw	2—Oil valve—Crankcase	.05
		1—Contact bracket	
		2—Oil valve—Magneto cover	
13M47	Machine screw	Condenser	.05
13M50	Insulator	Armature coil lead	.05
3058B	Nut	Gas pipe to carburetor	.05
590E	Washer	Valve cover plate	.05
796E	Washer	Contact bracket	.05
37346	Rivet	Air guide to magneto	.05 Doz.
61030	Cylinder head		2.25
*61042	Oil filler elbow		.45
	Note—No. 61086 Oil filler elbow used on side of cylinder.		
61067	Cam gear	Crankcase	5.00
61120	Base		6.00
61122	Governor lever	Governor	.40
61125	Intake pipe connector (with plain holes)	Intake pipe	.10
61126	Intake pipe connector (with tapped holes)	Intake pipe	.15

*Before ordering read the NOTE immediately below this part number.

28

Model and motor number must be given when writing or ordering parts

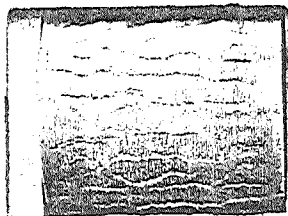

PARTS AND PRICE LIST

Part No.	Name	Where Used	Price Each
*61137	Starter pedal (Straight—13¼" long)		1.50
	Note—No. 61144 starter pedal (Straight 9¼" long) No. 61138		1.50
	Dog Leg pedal (Bent up 13¼" long)		1.50
61139	Starter pedal (Bent right—13¼" long)		1.50
*61140	Starter pedal (Bent left—13¼" long)		1.50
	Note—No. 61141 pedal (Bent left—11" long)		1.50
61142	Hand starting lever	Starter assembly	1.50
62015	Ratchet guard	Starter lever	.25
62024	Throttle spring clip		.05
62026	Locking plate	Throttle spring clip	.05
63060	Exhaust valve	Cylinder	1.50
63146	Intake pipe (upper half)		.15
63147	Intake pipe (lower half)		.45
*65075	Ground wire—6½" long (not illustrated)	Switch to contact bracket	.10
	Note—No. 65135 ground wire 11¾" long for switch on carburetor side.		
65126	Throttle spring		.15
65167	Insulator	Armature coil lead	.05
65194	Washer	Contact bracket—Magneto	.05
65314	Insulator (not illustrated)	Contact bracket	.05
65367	Felt	Ratchet nut	.01
*65451	Compression ring	Piston	.35
	Note—For oversize ring see No. 69137.		
65489	Breaker arm assembly	Magneto	.75
65522	Bracket	Side of blower case	.10
65607	Gasket	Oil valve housing—Crankcase	.05
		Oil valve housing—Magneto	
65617	Gasket	Valve cover plate	.10
65676	Spring	Exhaust and intake valves	.15
65722	Clamp	Air cleaner tube	.10
*65847	Ignition cable sleeve	Magneto	.10
	Note—Used only with cable No. 69275.		
65863	Piston pin	Piston	.30
66037	Gasket	Magneto	.05
66047	Gasket	Magneto	.05
66056	Return spring	Starter lever	.50
66057	Gasket	Crankcase	.25
66159	Clamps with stove bolt and nut	Air cleaner tube	.20
66186	Spring	Throttle Adj. screw on carburetor	.10
66206	Crankshaft		7.00
66246	Lock ring	Piston pin	.05
66403	Woodruff Key	Crankshaft	.05
66436	Throttle link	Governor lever to carburetor	.10
66446	Rivet	Starter chain	.01
66521	Plug	Gasoline filler on base	.10
66599	Air cleaner assembly		1.25
66679	Magneto flywheel		9.20
66733	Ratchet	Starter	.60
*66743	Ratchet Nut (Right hand)		

*Before ordering read the NOTE immediately below this part number.

29

Model and motor number must be given when writing or ordering parts

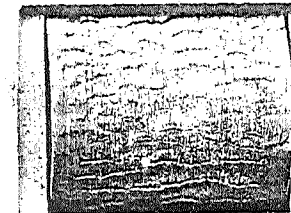

ARTS AND PRICE LIST

Part No.	Name	Where Used	Price Each
*66743	thread)	Starter	.30
(Cont.)	Note—No. 66903 Ratchet nut (Left hand thread)		.30
	Takes following:		
	No. 68133 left hand drive stud		.35
	No. 91157 left hand nut		.10
	No. 13B30 Lockwasher		.01
67072	Washer	Contact bracket—Magneto	.05
67083	Needle valve	Carburetor	.25
67429	Pawl assembly	Starter	.70
67652	Oil valve guide	1—Magneto cover plate oil sucker	.05
		1—Crankcase oil sucker	
67662	Oil valve	1—Magneto cover plate oil sucker	.05
		1—Crankcase oil sucker	
67753	Washer	Magneto flywheel	.05
67902	Washer	Governor gear to flange	.10
67929	Carburetor body assembly including carburetor body with No. 67083 needle valve		2.00
68022	Bracket	Blower case—upper	.10
68122	Plug	Camshaft—Crankcase	.01
*68133	Pulley drive stud	Pulley halves	.35
	Note—See No. 66743.		
*68161	Oil regulating ring	Piston	.50
	Note—For oversize rings see No. 69137.		
*68231	Piston		3.50
	Note—For oversize pistons—See No. 69137.		
68283	Valve spring retainer collar (consisting 2 halves)	Valves	.10
68291	Valve housing	1—Oil valve on magneto	.10
		1—Oil valve in crankcase	
68293	Valve spring retainer	Valves	.10
68303	Cam followers	Cylinder	1.00
68333	Cam shaft	Crankcase	.40
68442	Valve cover plate		.25
68449	Muffler assembly		1.25
68643	Governor crank	Crankcase	.80
68652	Spark plug wrench		.20
68803	Set Collar	Starter shaft	.30
68821	Sprocket	Starter chain	.25
68881	Bushing	Starter return spring	.05
68923	Intake valve		.75
69004	Gasket	Cylinder head	.25
69053	Magneto cover and armature	Including—	8.25
	1—No. 13A10 gasket .015" thick.		
	1—No. 66037 gasket .005"		
	1—No. 66047 gasket .009"		
	4—No. 37346 rivets.		
69105	Gov. shaft and flange assembly	Governor gear	.40
69130	Oil pump rod assembly	Oil pump	.30
*69137	Piston assembly—standard—including—		4.75
	1 No. 68231 piston	1 No. 68161 oil ring	
	2 No. 66246 lock rings	2 No. 65451 compression rings	
	Note—No. 69347 piston assembly .010" oversize includes..... 6.00		

*Before ordering read the NOTE immediately below this part number.

30

Model and motor number must be given when writing or ordering parts

PARTS AND PRICE LIST

Part No.	Name	Where Used	Price Each
*69137	1 No. 61108 piston .010" oversize		4.00
(Cont.)	1 No. 61009 oil ring .010" oversize		1.00
	2 No. 61010 Compression rings .010" oversize		.50
	2 No. 66246 Pin lock ring		.05
	Note—No. 69348 Piston assembly .020" oversize includes.....		6.00
	1 No. 61109 Piston .020" oversize		4.00
	1 No. 61010 oil ring .020" oversize		1.00
	2 No. 61012 Compression ring .020" oversize		.50
	2 No. 66246 Pin lock ring		.05
	Note—No. 69349 Piston assembly .030" oversize includes.....		6.00
	1 No. 61110 Piston .030" oversize		4.00
	1 No. 61017 oil ring .030" oversize		1.00
	2 No. 61013 Compression ring .030" oversize		.50
	2 No. 66246 Pin lock ring		.05
*69189	Cylinder assembly complete to take oil filler elbow under starter shaft—including following		27.50
	1 No. 63060 Exhaust valve	1 No. 69213 Clinder with bearings	
	1 No. 68333 Cam gear shaft	1 No. 68122 Cam gear shaft plug	
	1 No. 68923 Intake valve	1 No. 65607 Oil valve housing gasket	
	2 No. 65676 Valve spring	1 No. 68291 Oil valve housing	
	1 No. 67652 Oil valve guide	2 No. 68293 Valve spring retainer	
	1 No. 67662 Oil valve	2 No. 68283 Valve spring retainer collar	
	2 No. 68303 Cam followers	2 No. 7717 Lockwashers	
	1 No. 61067 Cam gear	2 No. 13M36 Machine screws	
	Note—No. 69309 same cylinder complete — to take oil filler elbow on side..... 27.50		
*69191	Magneto and air guide assembly complete with stop switch on foot starter side		12.00
	Note—No. 69352 Magneto and air guide assembly with switch on carburetor side..... 12.00		
69194	Governor gear and thrust cup assembly		1.50
*69213	Cylinder to take oil filler elbow under starter shaft—including.....		17.50
	1 No. 69346 Main bearing	1 No. 68653 Governor crank bearing	
	Note—No. 69310 cylinder with bearings—to take oil filler elbow on side..... 17.50		
*69218	Air guide with stop switch on starter side		.60
	Note—No. 69278 air guide with stop switch on carburetor side .60		
69232	Connecting rod assembly includes—		1.50
	2 No. 13A27 Cap screws	2 No. 13A2 Lockwashers	
	2 No. 13A34 Connecting rod shims		
69238	"V" Belt pulley 4 3/8" diameter.....		1.00
*69245	"V" Belt pulley 3" diameter with 1" long hub.....		.85
	Note—No. 69368 "V" Pulley 3" dia. with 1 1/2" long hub.. 1.00		
	63137 "V" Pulley 2 1/4" diameter85		
	66662 Pulley half 2 7/8" diameter25		
	67882 Pulley half 3" diameter25		
	61145 Flat belt pulley— 2 1/4" dia. x 1 3/4" face.. 3.25		
69259	Breather assembly		.75
*69275	Ignition cable standard—		
	takes sleeve No. 65847.....	Magneto	.50
	Note—No. 69382 Cable with sleeving braided on..... .50		
69282	Bearing assembly includes—	Magneto	1.25

*Before ordering read the NOTE immediately below this part number.

31

Model and motor number must be given when writing or ordering parts

PARTS AND PRICE LIST

Part No.	Name	Where Used	Price Each
69282	1 No. 63094 Bearing	1 No. 68692 Oil retainer ring	
(Cont.)	1 No. 67023 Retainer pin		
*69308	Blower case assembly with stop switch on starter side.....		1.35
	Note—No. 69351 Blower case with stop switch on carb. side....		1.35
69312	Chain	Starter	1.25
69333	Starter assembly includes following—		3.50
	1 No. 69312 Chain	1 No. 69334 Lever and shaft assembly	
	1 No. 66446 Tubular rivet	1 No. 62015 Ratchet guard	
	1 No. 68821 Sprocket	2 No. 7T17 Lockwashers	
	1 No. 91165 Rivet	2 No. 90077 Machine screws	
69334	Starter lever and shaft.....	Starter	2.00
69340	Crankshaft guard25
69346	Main cylinder bearing—complete—including—		1.25
	1 No. 63126 Bearing		
	1 No. 68543 Retainer pin		
	1 No. 68702 Oil retainer ring		
69386	Gas pipe assembly.....	Carburetor45
69392	Air cleaner tube assembly.....		.50
69353	Carburetor assembly includes the following—		2.75
	1 No. 67929 Carburetor body assembly		
	1 No. 69386 Gas pipe assembly		
	1 No. 3058B Nut		
	1 No. 66186 Throttle adjusting screw spring		
	1 No. 90074 Throttle adjusting screw		
69398	Oil trough and pan assembly.....		2.00
90074	Machine screw	Carburetor05
90077	Machine screw	Ratchet guard05
90597	Machine screw	Governor flange05
90680	Set screw	Set collar05
90802	Cap screw	Valve cover plate05
*90832	Lockwasher	1 on 13K301
	1—Upper blower bracket	3—Magneto plate	
	Note—Replaced by No. 91281 for magneto plate only.		
90835	Stove bolt with nut	Air cleaner clamp05
90878	Plug	Gasoline Drain05
90879	Cap screw	Cylinder head10
*90886	Plug	Oil filler10
	Note—Oil filler elbow which is cast on crankcase, takes filler cap No. 61136 .25; gasket No. 69409 .05.		
90887	Cap screw	Cylinder to base05
90891	Cap screw	On 13K305
90902	Machine screw	Magneto plate05
90916	Machine screw	2—Side blower bracket.....	.05
		1—Top blower bracket	
91083	Plug	Gasoline filler10
91165	Rivet	Starter chain to sprocket.....	.01
91223	Set screw	Belt Pulley05
91242	Locknut	Muffler05
91245	Close Nipple—Standard	Muffler15
91246	Elbow	Muffler40
91247	Cap screw	Starter pedal15
91248	Nut	Starter pedal05

*Before ordering read the NOTE immediately below this part number.

32

Model and motor number must be given when writing or ordering parts

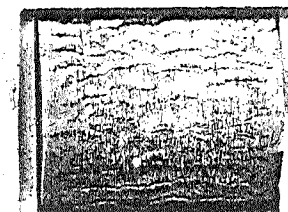
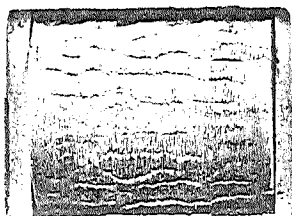

Free Manuals Download Website

<http://myh66.com>

<http://usermanuals.us>

<http://www.somanuals.com>

<http://www.4manuals.cc>

<http://www.manual-lib.com>

<http://www.404manual.com>

<http://www.luxmanual.com>

<http://aubethermostatmanual.com>

Golf course search by state

<http://golfingnear.com>

Email search by domain

<http://emailbydomain.com>

Auto manuals search

<http://auto.somanuals.com>

TV manuals search

<http://tv.somanuals.com>