

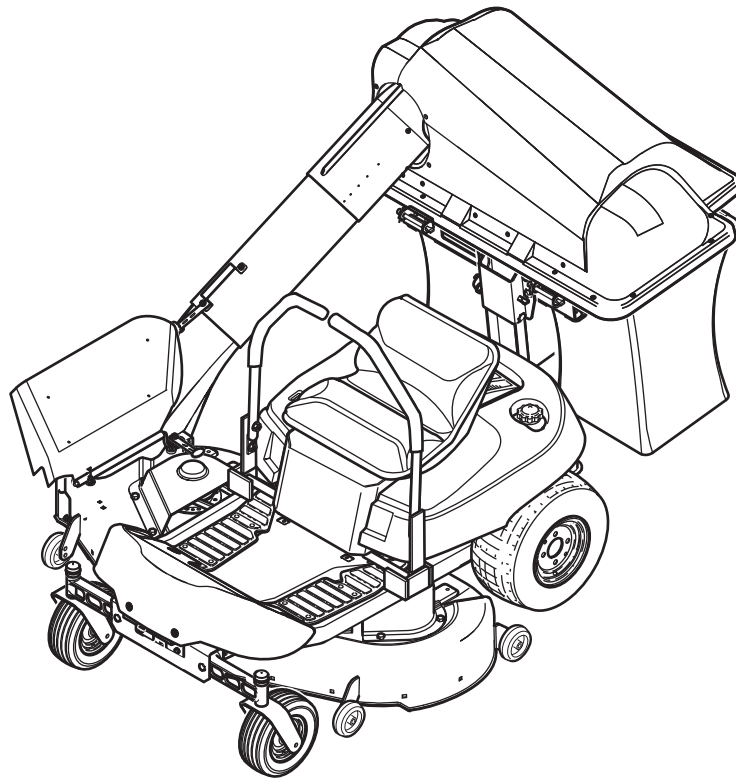

ATTACHMENT OPERATOR'S MANUAL



2-BIN BAGGER

50" 2-Bin Bagger

Mfg. No.	Description
1695284	50" 2-Bin Bagger

1734240

Rev. 00

Rev. Date 01/2007

TP 100-4452-00-AT-SN

THIS PAGE INTENTIONALLY BLANK

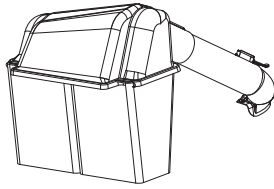

Table of Contents

Safety Rules & Information

General Warnings.....	2
Safety Decals	2

General Operating Instructions

Before Operation	3
Mowing with the Catcher	3
After Operation	3
Storing the Grass Catcher	3

Initial Installation

Counterweight Installation	4
Blowout Baffle Installation	4
Hitch Installation	5
Bag Support and Cover Installation.....	6
Bag Installation and Tube Assembly.....	7
Chute and Tube Installation	8

Normal Removal & Installation

Collector Installation	10
Collector Removal	11

NOTE: In these instructions, "left" and "right" are referred to as seen from the operating position.

Safety Rules & Information



Read these safety rules and follow them closely. Failure to obey these rules could result in loss of control of unit, severe personal injury or death to you, or bystanders, or damage to property or equipment. The triangle  in text signifies important cautions or warnings which must be followed.

GENERAL WARNINGS

- Know the unit's controls and how to stop quickly. **READ THE OPERATOR'S MANUALS.**
- Read and obey all safety decals.
- Only allow responsible adults, who are familiar with the instructions, to operate the unit.
- Disengage the PTO. Shut off the engine and wait for all moving parts to stop before attaching, adjusting, or disconnecting any part of the collection system.
- Check the collection system to make sure it is bolted tightly to the unit.
- DO NOT operate the unit without either the entire grass catcher or the deflector in place.
- Turn off the PTO to disengage the blades when not mowing.
- DO NOT mow in reverse unless absolutely necessary. Always look down and behind before and while travelling in reverse.
- DO NOT turn sharply when travelling alongside a building or any object. Slow down before turning.
- DO NOT carry passengers.
- When collection system is removed from the mower deck, the deflector must be properly installed.
- Collector bags are subject to deterioration and wear during normal use. Inspect the bag periodically for tears, holes, or weak spots and replace with a new bag that meets manufacturer's durability standards.
- If the mower stalls or the collector chute plugs:
 1. Disengage the PTO;
 2. Stop the engine and remove the key;
 3. Set the parking brake, and wait for all moving parts to stop.
 4. Remove the foreign object or clear the chute with a piece of wood before restarting the engine. **NEVER place hands into COLLECTOR OR MOWER housing to clear jammed objects. Blower OR MOWER may rotate when object is removed.**
- For added stability and to prevent tipping or loss of control:
 - a. Use reduced speed on uneven ground and when turning corners.
 - b. Reduce loads on hillsides. It is recommended that the collection system be kept only half full when negotiating any slopes. Start mowing on slopes when the collection system is empty.
 - c. Mow up and down the face of slopes; never across the face of any slope.
- **Never operate on slopes greater than 17.6% (10°).**

SAFETY DECALS

This unit has been designed and manufactured to provide you with the safety and reliability you would expect from an industry leader in outdoor power equipment manufacturing.

Although reading this manual and the safety instructions it contains will provide you with the necessary basic knowledge to operate this equipment safely and effectively, we have placed several safety labels on the unit to remind you of this important information while you are operating your unit.

All DANGER, WARNING, CAUTION and instructional messages on your rider, attachments and mower should be carefully read and obeyed. Personal bodily injury can result when these instructions are not followed. The information is for your safety and it is important! The safety decals below are on your product.

If any decals are lost or damaged, replace them at once. See your local dealer for replacements.

These labels are easily applied and will act as a constant visual reminder to you, and others who may use the equipment, to follow the safety instructions necessary for safe, effective operation.

Attachment Decal



Decal - WARNING
Thrown Objects Hazard
Part Number 1732819

Read and obey all operation and warning decals.



Operating Instructions



Before Operation

Clear the lawn of all sticks, stones, wire and other debris which may be caught or thrown by the mower blades.

Check grass condition. If wet, wait until later in the day. If grass is wet, the grass catcher is likely to become plugged.

For efficient bagging, air circulation under the mower deck, through the chute and into the bag is very important.

For this reason, **BEFORE YOU BEGIN MOWING** you should make certain the underside of the mower and the underside of the catcher lid are free from grass and debris.

Make sure that there is a snug fit between mower deck, blower housing, tubes, and grass catcher cover.

Mowing with the Catcher

Always operate with throttle at full speed when mowing.

Grass should be cut often, and not too short. If grass is too long or lush it may be necessary to keep ground speed to a minimum or to cut only half the width of the mower to prevent clogging. If grass is long, operate with mower in high cutting position for first pass, cutting again in a lower position on a second pass.

Do not open the cover with mower engaged.

If a large amount of cut grass is spilling out from under deck, the tube may be plugged or the bags may be full—discontinue mowing, stop the unit, disengage the PTO, shut off the engine and then empty the catcher or clear the tube.

! WARNING

ALWAYS shut off the tractor. Disengage the PTO, and allow all moving parts to stop **BEFORE** disconnecting or clearing tube, or emptying catcher.

Before leaving the operator's position for any reason, engage the parking brake, disengage the PTO, stop the engine and remove the key.

To reduce fire hazard, keep the engine, rider and mower free of grass, leaves and excess grease. Do not stop or park rider over dry leaves, grass or combustible materials.

! CAUTION

Before you begin operating the unit be certain you have read all of the safety and operational information of this instruction sheet, as well as the Operator's Manual for the tractor and any other attachments.

Never operate on slopes greater than 17.6% (10°).

After Operation

Remove any debris from the the screen on the underside of the lid.

The blower housing and tube should be removed for cleaning.

Inspect the grass bags for wear or damage. Make sure that there is a snug fit between mower deck, blower housing, tubes, and grass catcher cover.

! CAUTION

Do not leave grass in bagger containers. Empty containers after each use and before storing. Failure to do so may result in spontaneous combustion which could develop into a fire.

Storing The Grass Catcher

Clean the grass catcher thoroughly using a mild detergent (other products may damage the tube). Remove any debris from the screen on the underside of the lid.

If paint has been scratched on metal parts, touch up with paint, or apply a thin film of oil to prevent corrosion.

Store in a dry area. Dry thoroughly before storing for a long period of time. Always store away from moisture.

Initial Installation

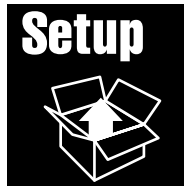

NOTE: In this manual, “left” and “right” are always defined from the standpoint of the operator position facing forward from seat.

⚠ WARNING

To avoid serious injury, engage parking brake, disengage PTO, stop engine, remove key and disconnect spark plug(s) before attempting to install, remove or work on the mower.

COUNTERWEIGHT INSTALLATION

1. Slide pins (A, Figure 1) on counterweight (B) into slots (C) on front footrest support bracket (D).
2. Secure counterweight (B) with pin (E) to front footrest support (D).
3. Secure pin (E) with safety clip (F).

SAFETY RULES

1. Never operate mower on slopes greater than 10°.
2. Front counter weight is required when ever using rear mounted grass collection system.

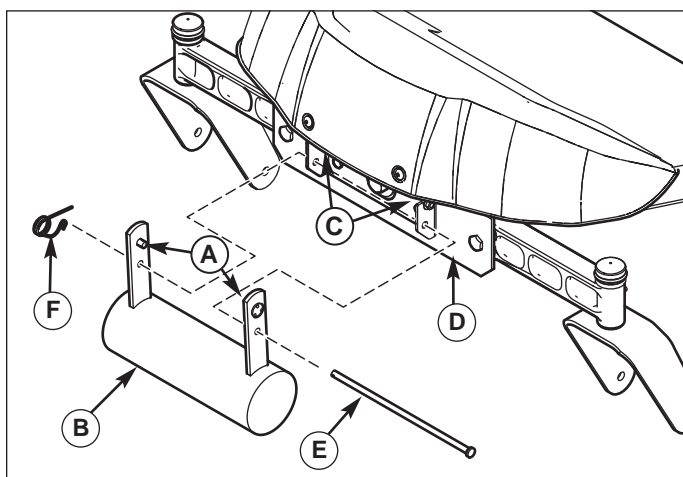

Figure 1. Install Counter Weight

- A. Slide Pins
- B. Counter Weight
- C. Pin Slots
- D. Front Footrest Support
- E. Pin
- F. Safety Clip

INSTALL BLOWOUT BAFFLES

1. Remove and discard existing baffles (A, Figure 2), carriage bolts (B) and nuts (C) from mower deck housing (D).

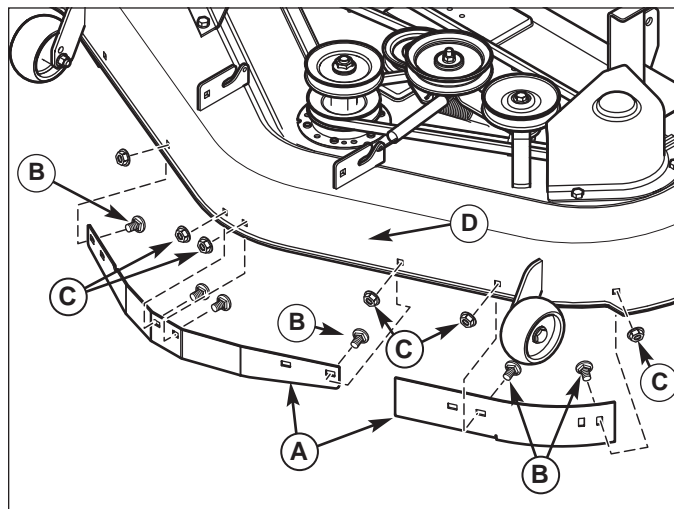

Figure 2. Remove Baffle and Hardware

- A. Baffles
- B. Carriage Bolts
- C. Nuts
- D. Mower Deck Housing

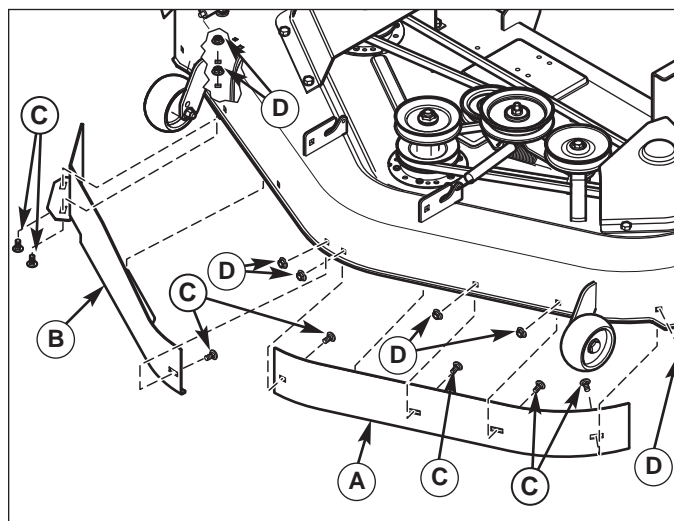

Figure 3. Blowout Baffle Installation

- A. Baffle, RH
 - B. Baffle, LH
 - C. Carriage Bolts, 5/16-18 x 5/8"
 - D. Nut, Whiz Lock, 5/16-18
2. Install RH baffle (A, Figure 3), and secure with 5/16-18 x 5/8" carriage bolts (C) and 5/16-18 Whiz Lock nuts (D).
 3. Install LH baffle (B), and secure with 5/16-18 x 5/8" carriage bolts (C) and 5/16-18 Whiz Lock nuts (D).

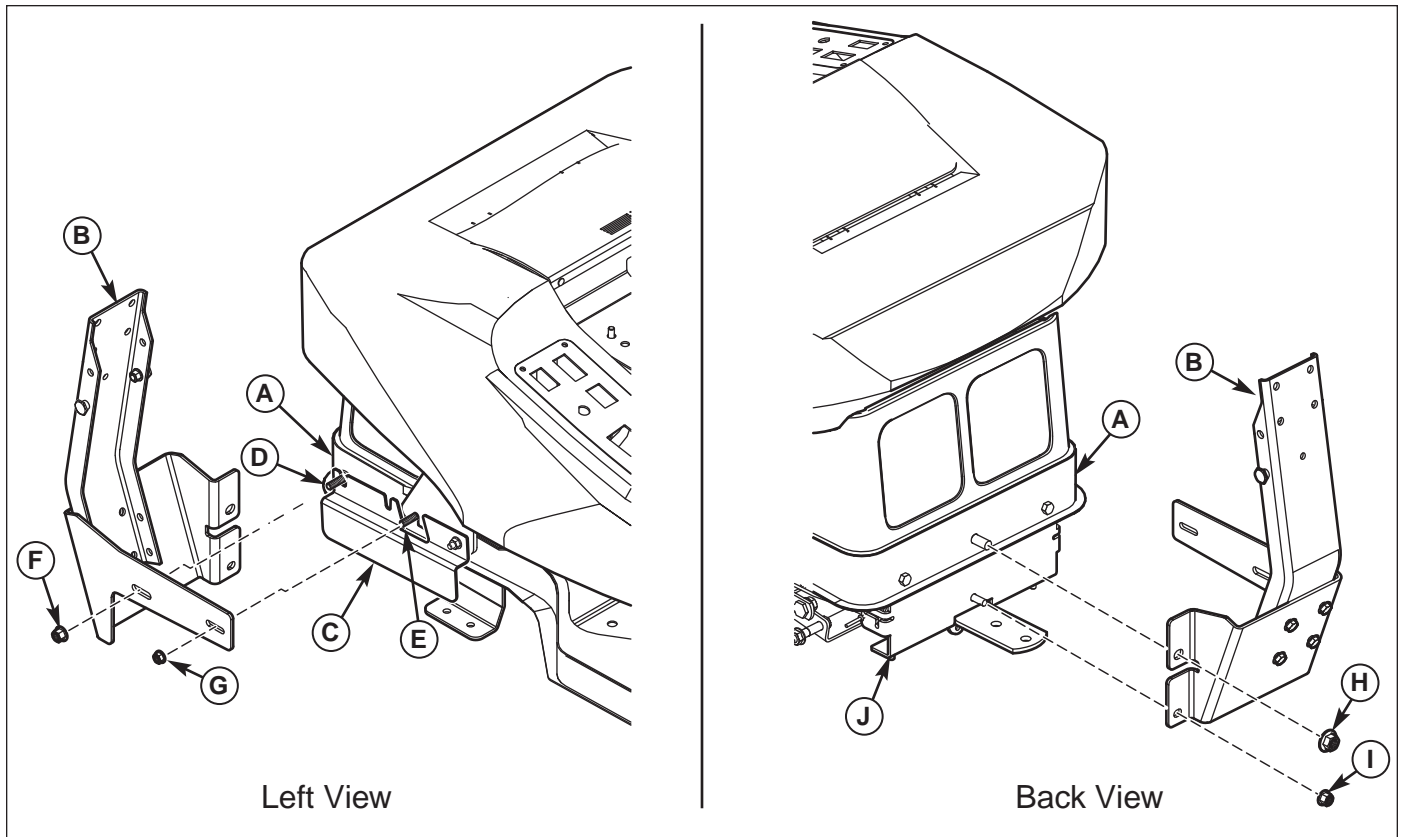

Figure 4. Install Hitch Assembly

- A. Frame**
- B. Hitch Assembly**
- C. Debris Guard**
- D. Capscrew, Debris Guard, 3/8-16**
- E. Capscrew, Seat Deck Support, 5/16-18**

- F. Nut, Nylock, Flanged 3/8-16**
- G. Nut, Nylock, Flanged 5/16-16**
- H. Nut, 1/2-13**
- I. Nut, 3/8-16**
- J. Rear Transmission Support**

HITCH INSTALLATION

Hitch Installation

1. Remove 5/16-16 nut (G, Figure 4) from seat deck support cap screw (E).
2. Remove 3/8-16 nut (F) from rear debris guard cap screw (D).
3. Remove 1/2-13 nut (H) from rear of frame (A).
4. Remove 3/8-16 nut (I) from rear transmission support (J).
5. Attach hitch assembly (B) to frame (A) sliding rear of hitch flush with frame.
6. Finger tighten 3/8-16 nut (F), 5/16-16 nut (G), 1/2-13 nut (H) and 3/8-16 nut (I).
7. Tighten 3/8-16 nut (F) and 5/16-16 nut (G) first, then 1/2-13 nut (H) and 3/8-16 nut (I).

Bag Support and Cover Installation

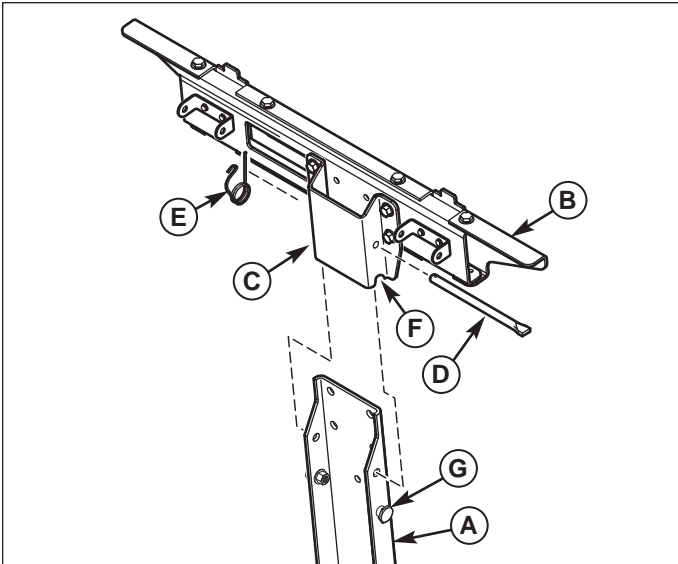

Figure 5. Install Bag and Cover Support

- A. Upright Support
- B. Bag and Cover Support
- C. Support Mount
- D. Mount Pin
- E. Retainer Spring
- F. Shoulder Rest
- G. Shoulder Bolt

Bag Support Installation

1. Attach the bag and cover support (B, Figure 5) to the upright support (A) by sliding the support mount (C) over the upright support (A) until the shoulder rest (F) makes full contact with the shoulder bolts (G).
2. Insert mount pin (D) through the support mount (C) and upright support (A) as shown.
3. Secure mount pin (D) with retainer spring (E).

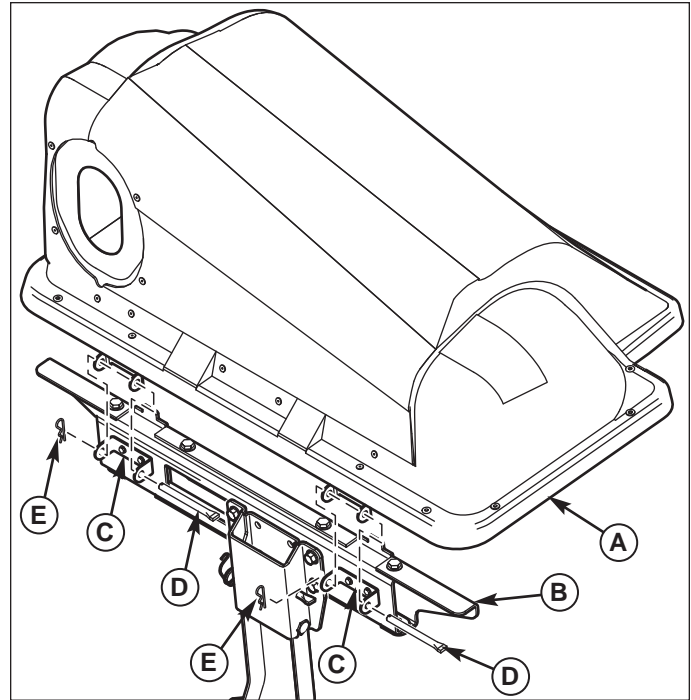

Figure 6. Cover Installation

- A. Cover Assembly
- B. Bag Support Bracket
- C. Cover Hinge Pivots
- D. Hinge Pins
- E. Retainer Springs

INSTALL COVER

1. Attach cover assembly (A, Figure 6) to bag support bracket (B) using cover hinge pivots (C). Secure cover assembly to bag support bracket using hinge pins (D) and retainer springs (E) as shown.

Bag Installation and Tube Assembly

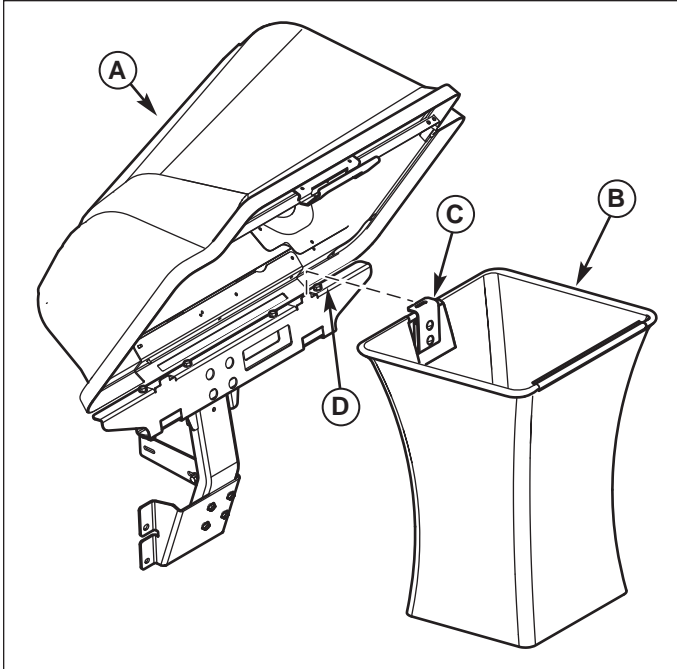

Figure 7. Install Collector Bags

- A. Cover
- B. Collector Bags
- C. Grass Bag Hanger
- D. Bag Hanger Post

INSTALL COLLECTOR BAGS

1. Raise the cover (A, Figure 7).
2. Attach collector bags (B) using grass bag hanger (C) to bag hanger post (D).

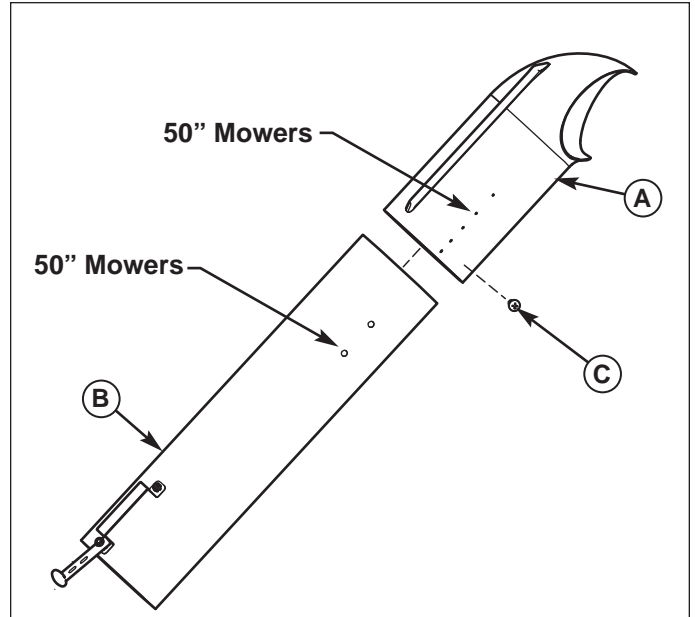

Figure 8. Middle and Upper Tube Assembly

- A. Upper Tube
- B. Middle Tube
- C. Screw, 1/4 x 3/4

CONNECTING UPPER AND MIDDLE TUBE

1. Slide the upper tube (A, Figure 8) over middle tube (B) and secure together using screw (C).

In upper tube:

- Fourth hole from end is for 50" mowers

See Figure 8 for hole locations.

Chute and Tube Installation

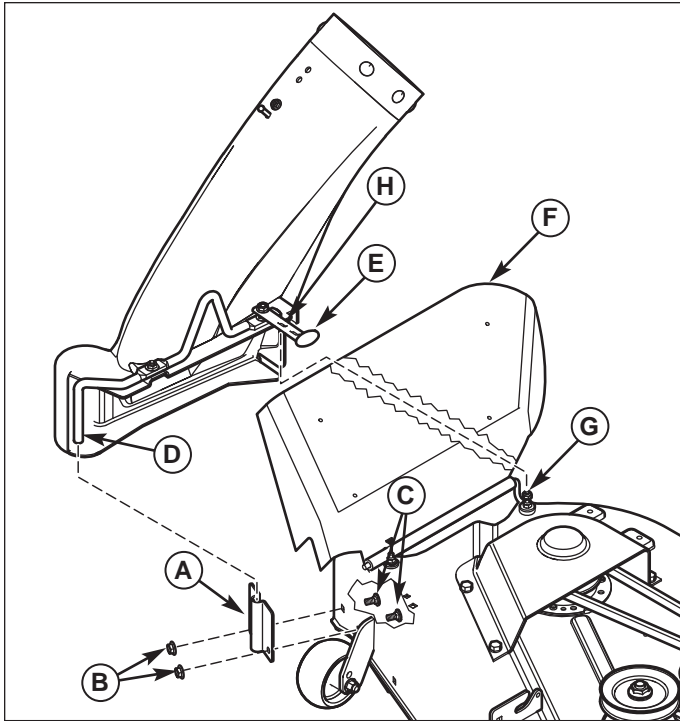

Figure 9. Install Chute

- A. Mounting Plate
- B. Locknuts, 5/16-18
- C. Carriage Bolt, 5/16-18 x 5/8
- D. Chute Rod
- E. Rubber Strap
- F. Discharge Deflector
- G. Locknut
- H. Mounting Hole

Chute Installation

1. Install mounting plate (A, Figure 9) to mower deck as shown. Secure with 5/16-18 x 5/8 carriage bolts (C) and 5/16-18 locknuts (B).
2. Lift discharge deflector (F).
3. Insert lower chute rod (D) into mounting plate (A).
4. Pull rubber strap (E) below discharge deflector, and secure by placing hole (H) over locknut (G).

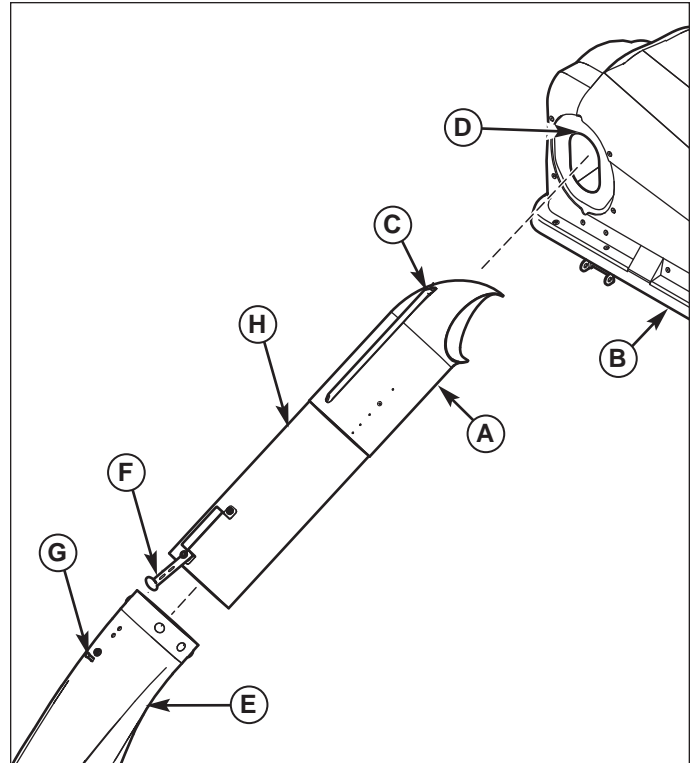

Figure 10. Connecting Tube Assembly to Lower Chute and Cover

- A. Upper Tube
- B. Cover
- C. Ridge, Upper Tube
- D. Ridge Cutout
- E. Lower Chute
- F. Strap, Rubber
- G. Pin
- H. Tube Assembly

CONNECTING TUBE ASSEMBLY TO CHUTE AND COVER

1. Slide the upper tube (A, Figure 10) into cover (B) aligning ridge (C) with cutout (D) as shown.
2. Slide tube assembly (H) over lower chute (E). Secure tube assembly (H) to lower chute (E) using strap (F) and pin (G).

THIS PAGE INTENTIONALLY BLANK

Normal Installation & Removal

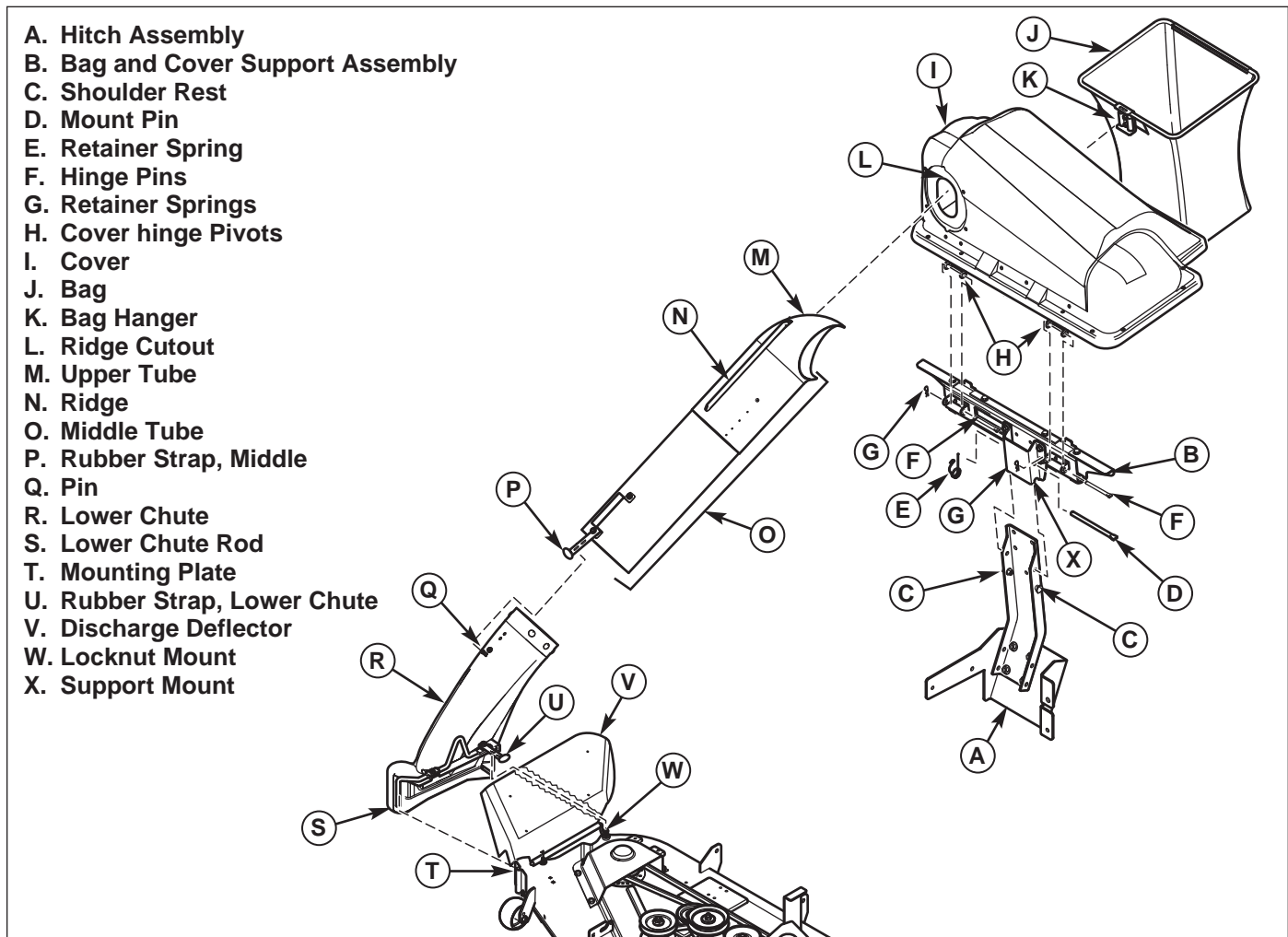

Figure 11. Normal Installation & Removal

NORMAL INSTALLATION & REMOVAL

Installation

NOTE: See previous pages for more detailed installation and operation instructions if necessary.

1. Attach bag and cover support assembly (B) to hitch support assembly (A) by sliding the support mount (X) over the upright support until the support mount (X) makes full contact with the shoulder bolts (C).
2. Insert mount pin (D) through the support mount (X) and upright support (A) as shown.
3. Secure mount pin (D) with retainer spring (E).
4. Attach cover assembly (I) to bag support bracket (B) using cover hinge pivots (H). Secure cover assembly to bag support bracket using hinge pins (F) and retainer springs (E).
5. Raise the cover (I), attach collector bags (J) using grass bag hanger (K) to bag hanger post (D, Figure 7).
6. Lift discharge deflector (V) up and insert lower chute rod (S) into mounting plate (T).
7. Pull rubber strap (U) below discharge deflector (U) and secure lower chute (R) to mower deck by placing hole in rubber strap (U) (hole closest to lower chute) over locknut mount (W).
8. Slide upper tube (M) into cover (I) aligning ridge (N) with ridge cutout (L).
9. Slide tube assembly (O) over lower chute (R) securing tube assembly (O) to lower chute (R) using rubber strap (P) on tube assembly (O) to pin (Q) on lower chute (R).

WARNING

OPERATION WITHOUT BAGGER

For operation without bagger, the mower discharge deflector **MUST** be properly installed in the down position and retained by the spring latch.

Removal

1. Unhook rubber strap (P, Figure 11) from pin (Q), then remove tube assembly (O) from chute (R) and from cover (I).
2. Lift cover (I) and remove bags (J) from bag and cover support assembly (B).

Note: Support the cover during the next step.

3. Remove cover (I) by disconnecting retainer springs (G), then remove both hinge pins (F).
4. Remove bag and cover support assembly (B) from hitch assembly (A) by removing retainer spring (E), then removing mount pin (D).

Note: To prevent loss of pins and retainer springs re-attach them to the cover, and bag and cover support assembly.

5. Remove wing nut (U) from carriage bolt (W).
6. Remove knob (S) from carriage bolt (T).
7. Lift up discharge deflector (V) and remove chute (R) from carriage bolt (T and W).

IMPORTANT: See that discharge deflector (R) returns to the DOWN position.



MANUFACTURING, INC.
Simplicity Mfg. Inc. 500 N Spring
Street / PO Box 997
Port Washington, WI 53074-0997

www.SimplicityMfg.com



Simplicity Mfg. Inc. - Snapper Products
535 Macon Street
McDonough, GA 30253

www.Snapper.com

Briggs & Stratton Yard Power Products Group
Copyright © 2007 Briggs & Stratton Corporation
Milwaukee, WI USA. All Rights Reserved

Free Manuals Download Website

<http://myh66.com>

<http://usermanuals.us>

<http://www.somanuals.com>

<http://www.4manuals.cc>

<http://www.manual-lib.com>

<http://www.404manual.com>

<http://www.luxmanual.com>

<http://aubethermostatmanual.com>

Golf course search by state

<http://golfingnear.com>

Email search by domain

<http://emailbydomain.com>

Auto manuals search

<http://auto.somanuals.com>

TV manuals search

<http://tv.somanuals.com>