

BES-1210AC BAS-416A

INSTRUCTION MANUAL

BROTHER
EMBROIDERY
SYSTEMS



Please read this manual before using the machine.
Please keep this manual within easy reach for quick reference.

SINGLE HEAD ELECTRONIC EMBROIDERY MACHINE

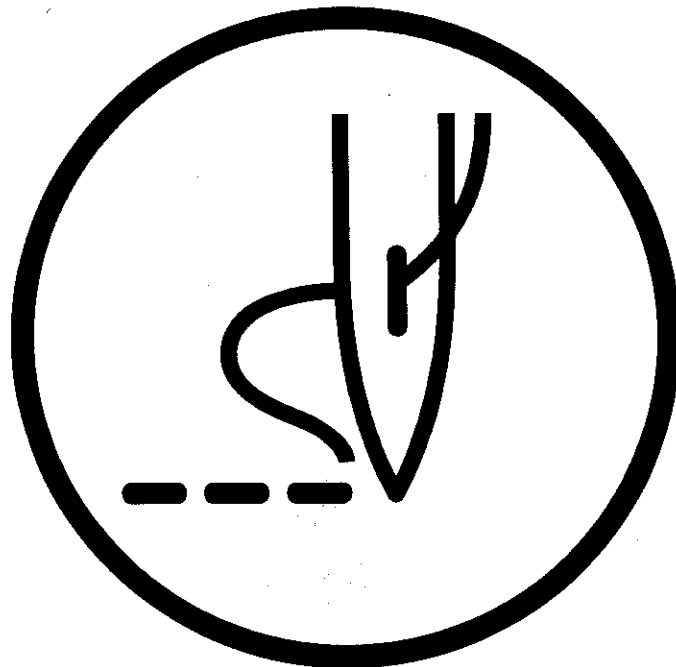

brother

Thank you very much for buying a BROTHER sewing machine. Before using your new machine, please read the safety instructions below and the explanations given in the instruction manual.



With industrial sewing machines, it is normal to carry out work while positioned directly in front of moving parts such as the needle and thread take-up lever, and consequently there is always a danger of injury that can be caused by these parts. Follow the instructions from training personnel and instructors regarding safe and correct operation before operating the machine so that you will know how to use the machine correctly.

SAFETY INSTRUCTIONS

1 Safety indications and their meanings

This instruction manual and the indications and symbols that are used on the machine itself are provided in order to ensure safe operation of this machine and to prevent accidents and injury to yourself or other people. The meanings of these indications and symbols are given below.

Indications

 DANGER	The instructions which follow this term indicate situations where failure to follow the instructions will almost certainly result in death or severe injury.
 CAUTION	The instructions which follow this term indicate situations where failure to follow the instructions could cause injury when using the machine or physical damage to equipment and surroundings.

Symbols



----- This symbol(\triangle) indicates something that you should be careful of. The picture inside the triangle indicates the nature of the caution that must be taken.
(For example, the symbol at left means "beware of injury".)



----- This symbol(\otimes) indicates something that you must not do.



----- This symbol(\bullet) indicates something that you must do. The picture inside the circle indicates the nature of the thing that must be done.
(For example, the symbol at left means "you must make the ground connection".)

2 Notes on safety

DANGER



Wait at least 5 minutes after turning off the power switch and disconnecting the power cord from the wall outlet before opening the face plate of the control box. Touching areas where high voltages are present can result in severe injury.

CAUTION

Installation



Machine installation should only be carried out by a qualified technician.



Contact your Brother dealer or a qualified electrician for any electrical work that may need to be done.



The sewing machine weighs more than 195 kg. The installation should be carried out by two or more people.



Do not connect the power cord until installation is complete, otherwise the machine may operate if the foot switch is depressed by mistake, which could result in injury.



Be sure to connect the ground. If the ground connection is not secure, you run the risk of receiving a serious electric shock.



Be sure to wear protective goggles and gloves when handling the lubricating oil and grease, so that they do not get into your eyes or onto your skin, otherwise inflammation can result. Furthermore, do not drink the oil or eat the grease under any circumstances, as they can cause vomiting and diarrhoea.

Keep the oil out of the reach of children.



Avoid setting up the sewing machine near sources of strong electrical noise such as high-frequency welding equipment. If this precaution is not taken, incorrect machine operation may result.

Sewing



This sewing machine should only be used by operators who have received the necessary training in safe use beforehand.



The sewing machine should not be used for any applications other than sewing.



Attach all safety devices before using the sewing machine. If the machine is used without these devices attached, injury may result.



Turn off the power switch at the following times, otherwise the machine may operate if the foot switch is depressed by mistake, which could result in injury.

- When threading the needle
- When replacing the bobbin and needle
- When not using the machine and when leaving the machine unattended



Do not touch any of the moving parts or press any objects against the machine while sewing, as this may result in personal injury or damage to the machine.



If an error occurs in machine operation, or if abnormal noises or smells are noticed, immediately turn off the power switch. Then contact your nearest Brother dealer or a qualified technician.



If the machine develops a problem, contact your nearest Brother dealer or a qualified technician.

⚠ CAUTION

Cleaning



Turn off the power switch before starting any cleaning work, otherwise the machine may operate if the foot switch is depressed by mistake, which could result in injury.



Be sure to wear protective goggles and gloves when handling the lubricating oil and grease, so that they do not get into your eyes or onto your skin, otherwise inflammation can result. Furthermore, do not drink the oil or eat the grease under any circumstances, as they can cause vomiting and diarrhoea. Keep the oil out of the reach of children.

Maintenance and inspection



Maintenance and inspection of the sewing machine should only be carried out by a qualified technician.



Ask your Brother dealer or a qualified electrician to carry out any maintenance and inspection of the electrical system.



Turn off the power switch and disconnect the power cord from the wall outlet at the following times, otherwise the machine may operate if the foot switch is depressed by mistake, which could result in injury.

- When carrying out inspection, adjustment and maintenance
- When replacing consumable parts such as the rotary hook and knife



If the power switch needs to be left on when carrying out some adjustment, be extremely careful to observe all safety precautions.



Use only the proper replacement parts as specified by Brother.



If any safety devices have been removed, be absolutely sure to re-install them to their original positions and check that they operate correctly before using the machine.



Any problems in machine operation which result from unauthorized modifications to the machine will not be covered by the warranty.

3 Warning labels

★ The following warning labels appear on the sewing machine. Please follow the instructions on the labels at all times when using the machine. If the labels have been removed or are difficult to read, please contact your nearest Brother dealer.

1

	▲ DANGER	▲ GEFAHR	▲ DANGER	▲ PELIGRO
	Hazardous voltage will cause injury. Turn off main switch and unplug power cord before opening this cover.	Hochspannung verletzungsgefahr! Vor Öffnen des Gehäuses Hauptschalter ausschalten und Netzstecker ziehen!	Un voltage non adapté provoque des blessures. Pour ouvrir cette plaque, couper le contact general de la machine et debrancher le cable d'alimentation.	Un voltaje inadecuado puede provocar las heridas. Antes de abrir esta tapa, desconecte la máquina y desenchufela de la red.

2

▲ CAUTION	
	Moving parts may cause injury.
	Operate with safety devices. Turn off main switch before changing needle, cleaning etc.

Safety devices: Finger guard, Guard bar, Belt cover, etc.

3



Never touch or push the thread take up during operation as it may result in injuries machine.

4



Never touch or push the needle bar during operation as it may result in injuries or damage to the sewing machine.

5

Direction of operation



■ BES-1210AC

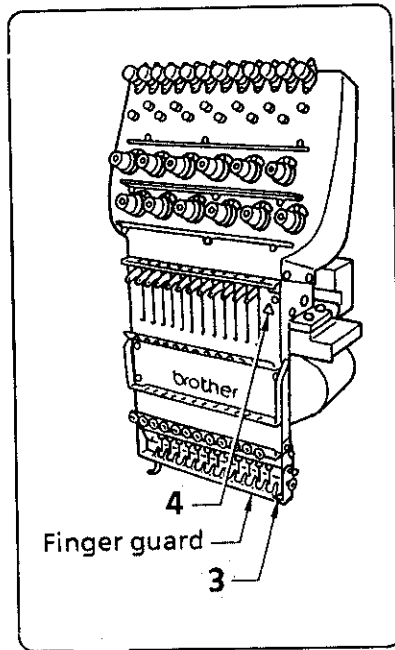

Finger guard

■ BAS-416A

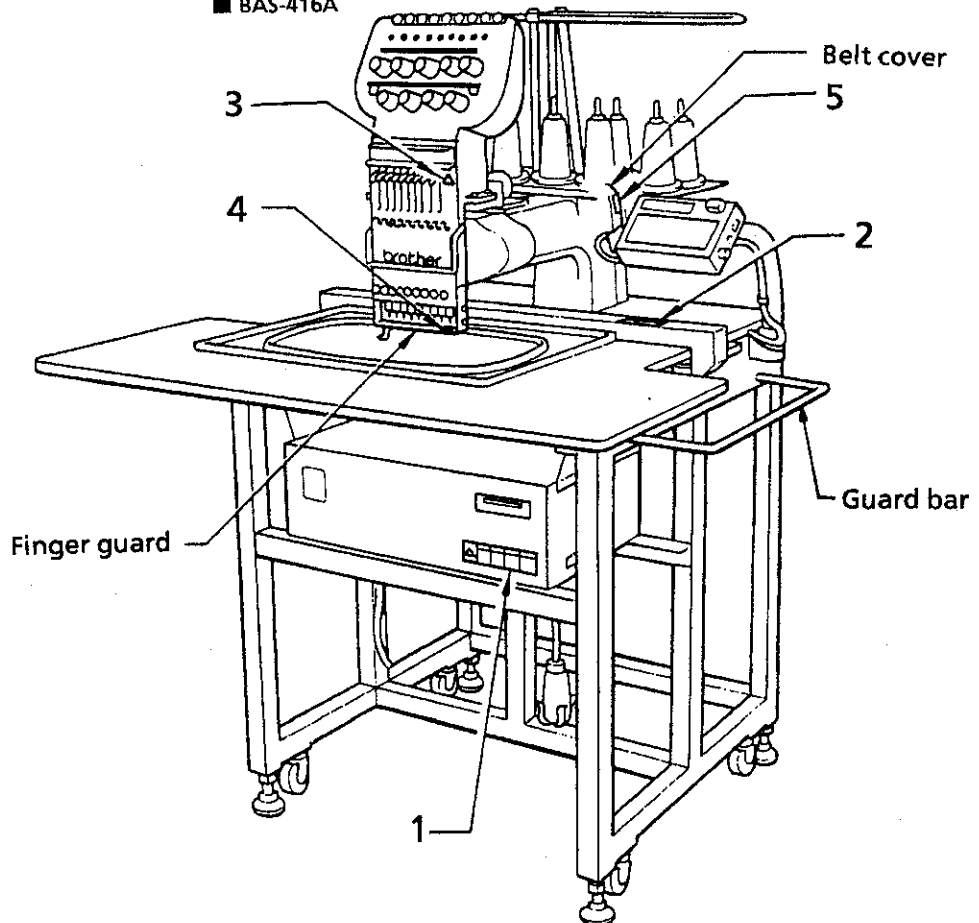

Finger guard

Belt cover

Guard bar

CONTENTS

Chapter 1. An Introduction of Embroidery Machine	1
1. Machine features	1
2. Specifications	2
Chapter 2. Preparation of Embroidery Machine	3
1. Names of machine components	3
2. Installation	4
2-1. Transportation of machines	4
2-2. Installation of machines	4
2-3. Installation operation panel	5
2-4. Installing guard bar	5
2-5. Power	6
3. Preparation of machine	6
3-1. Confirm the following before switching on the machine	6
3-2. When turning on the power of the machine	7
4. Preparation for embroidering	10
4-1. Replacing bobbin	10
4-2. Replacing and selecting needle	10
4-3. Upper threading	11
4-4. Thread tension	13
Needle thread tension	13
Bobbin thread tension	13
4-5. Attaching embroidery hoop to holder base	14
Attaching plastic square hoop to holder base	14
Attaching tubular square hoop to holder base (Optional)	15
Attaching sashes frame set (Option)	16
Chapter 3. Operation of Machine	18
1. Default sewing of patterns	18
2. Repeat sewing	21
3. Restarting	26
Chapter 4. Embroidering Procedures	28
1. Flow chart	28
2. Inserting floppy disk	29
3. Names and functions of operation panel	30
3-1. Names	30
3-2. Functions of keys on operation panel	31
3-3. LED lamp	35
3-4. Operation panel display	36
4. Dip switch functions	37
4-1. Dip switch functions on main printed circuit board	37
4-2. Dip switch functions on operation panel	38

Chapter 5. Entering Embroidery Date	39
Data available in BAS-416A · BES-1210AC	39
Summary of main menu	40
1. Entering floppy disk data	41
2. Entering data from paper tape	46
3. Entering data from BAS-PC/EM system	49
Chapter 6. Editing Embroidery Data	53
1. Editing method	53
2. Editing function	56
2-1. Rotating	56
2-2. Setting mirror image	57
2-3. Setting repeat sewing	58
Chapter 7. Sewing Function	60
1. Explanation of sewing function	60
2. Setting hoop feed point	61
3. Needle bar setting	63
4. Selecting needle bar	65
5. Setting bobbin thread counter and thread breakage sensor	66
6. Function of speed volume table setting	68
7. Function of speed setting for test feed	70
8. Function of sewing area selection	71
• Function of sewing area according to the type of frame (flat frame mode)	71
• Function of optional setting of sewing area by specifying two points (flat frame mode)	72
• Function of selection of sewing area by the type of frame (cap frame mode)	74
• The relation between SW at time of power on and sewing area	75
9. Function of setting feed volume of thread pulling at time of thread trimming	76
10. Skip function of 0 mm stitch	77
11. Function to select alarm at time of thread breakage	78
12. Sensitivity switching function for the thread breakage sensor	79
13. Thread trimmer operation activation/ deactivation setting function	80
14. Mask check activation/ deactivation setting function	81
Chapter 8. Connection and Installation of Optional Equipment	82
1. Tape reader	82
2. Bobbin winder (Option)	86
Chapter 9. Maintenance	88
1. Cleaning	88
2. Oiling	89

Chapter 10. Standard Adjustment	91
1. Adjusting needle bar height	91
2. Adjustment of timing between needle and rotary hook	95
3. Adjustment of presser foot height	95
4. Adjusting the belt tension	96
Chapter 11. Error Messages	97
Chapter 12. Troubleshooting	100

Explanation of models

This manual explains two models:

- BAS-416A (9 needles)
- BES-1210AC (12 needles)

Explanation for individual model is provided by identifying the model name. Check the model before using the machine.

Chapter 1. An Introduction of Embroidery Machine

1. Machine features

- This interactive machine is based on dialogue system and enables even a complete beginner to easily embroider multi-colored patterns.
- By setting a program in advance, thread changing and thread trimming can be done automatically. Up to 99 colors can be put in a pattern and up to 27000 stitches can be stored in the memory as standard use. By running a 2DD floppy disk, up to 240000 stitches can be sewn in a pattern.
- Up to 16 patterns can be entered in the memory. By entering a pattern in advance, it can be sewn anytime. By using the memory expansion board (optional), up to 280000 stitches can be put in the memory.
- If the tape reader (optional) is connected, the tapes of Tajima, Barudan and Zangs format (1 inch/8 holes), and the floppy disk of Tajima, and the receive data from Brother's editing system can be used.
[NOTE] Brother format data cannot be used.
- By removing the table and using the cylinder bed, embroidery for tubular materials can be done effortlessly using an optional hoop. The maximum sewing area is H 450 mm x V 300 mm and it is possible to fully embroider the back of the jacket. By attaching cap frame device (optional), beautiful embroidering can be performed on ready made caps.
- Its wide sewing area is H 450 mm x V 300 mm, and removal of the embroidery frame can be done easily. Also, convenient bobbin thread counter is equipped as standard use.

2. Specifications

■ BAS-416A

Embroidery machine used	9 needle embroidery machine
Application	Pattern embroidery
Sewing speed	Maximum 1200 spm (4 levels)
Sewing area	V 300 mm x H 450 mm (holder base area) V 300 mm x H 450 mm (tubular square hoop area)
Feed method	Pulse motor wire-drive method
Stitch length	0.1 mm - 12.7 mm (minimum pitch 0.1 mm)
Storage medium	3.5 2DD floppy disk in Tajima format 3.5 2HD floppy disk which corresponds to Tajima format paper tape with 25.4 mm width /8 holes (Tajima, Barudan, Zangs)
Thread trimming	Automatic thread trimmer
Needle thread breakage	Needle thread breakage detector
Power supply	Single phase 240V, 220V, 200V, 120V maximum 500VA
Weight	195kg
Dimensions	W 1050 mm x L 940 mm x H 1380 mm
Options	Paper tape reader, embroidery hoop in each size, ML 651 lamp set, bobbin winder, accessory case, cap frame device, boring attachment, plate for shelf, marking light, memory expansion board

■ BES-1210AC

Embroidery machine used	12 needle embroidery machine
Application	Pattern embroidery
Sewing speed	Maximum 1200 spm (4 levels)
Sewing area	V 300 mm x H 450 mm (holder base area) V 300 mm x H 450 mm (tubular square hoop area)
Feed method	Pulse motor wire-drive method
Stitch length	0.1 mm - 12.7 mm (minimum pitch 0.1 mm)
Storage medium	3.5 2DD floppy disk in Tajima format 3.5 2HD floppy disk which corresponds to Tajima format paper tape with 25.4 mm width /8 holes (Tajima, Barudan, Zangs)
Thread trimming	Automatic thread trimmer
Needle thread breakage	Needle thread breakage detector
Power supply	Single phase 240V, 220V, 200V, 120V maximum 500VA
Weight	195kg
Dimensions	W 1050 mm x L 940 mm x H 1380 mm
Options	Paper tape reader, embroidery hoop in each size, ML 651 lamp set, bobbin winder, accessory case, cap frame device, boring attachment, plate for shelf, marking light, memory expansion board

Chapter 2. Preparation of Embroidery Machine

1. Names of machine components

■ BAS-416A

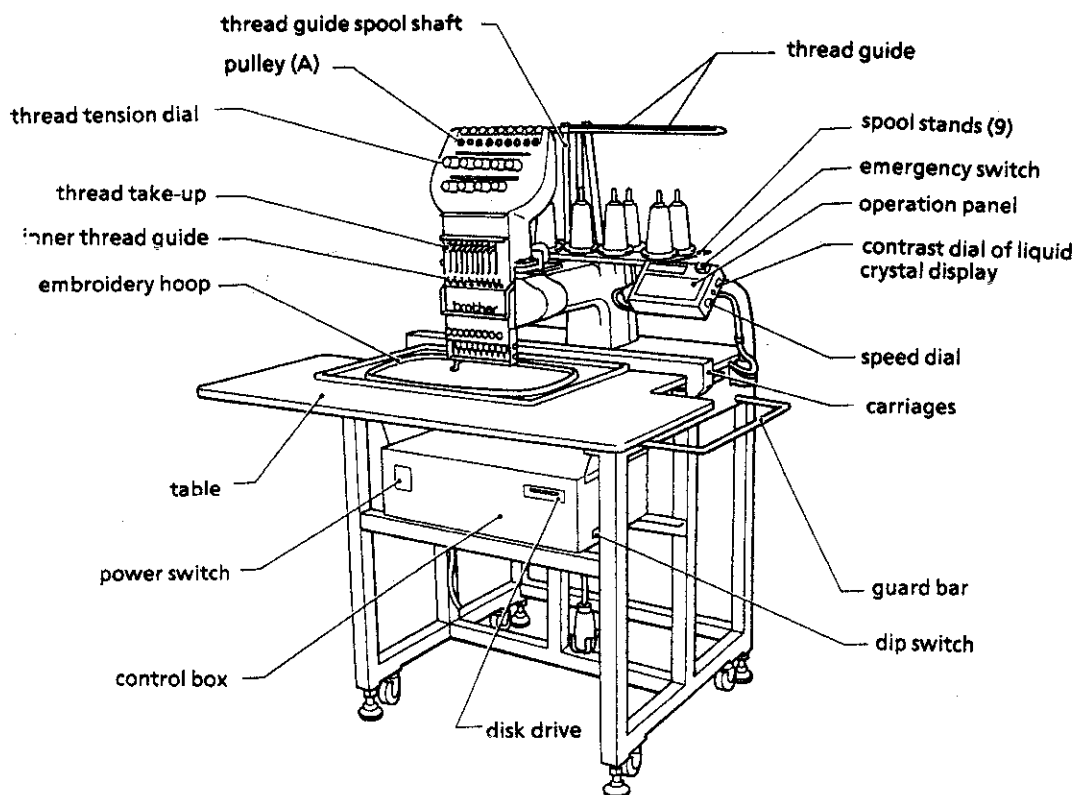



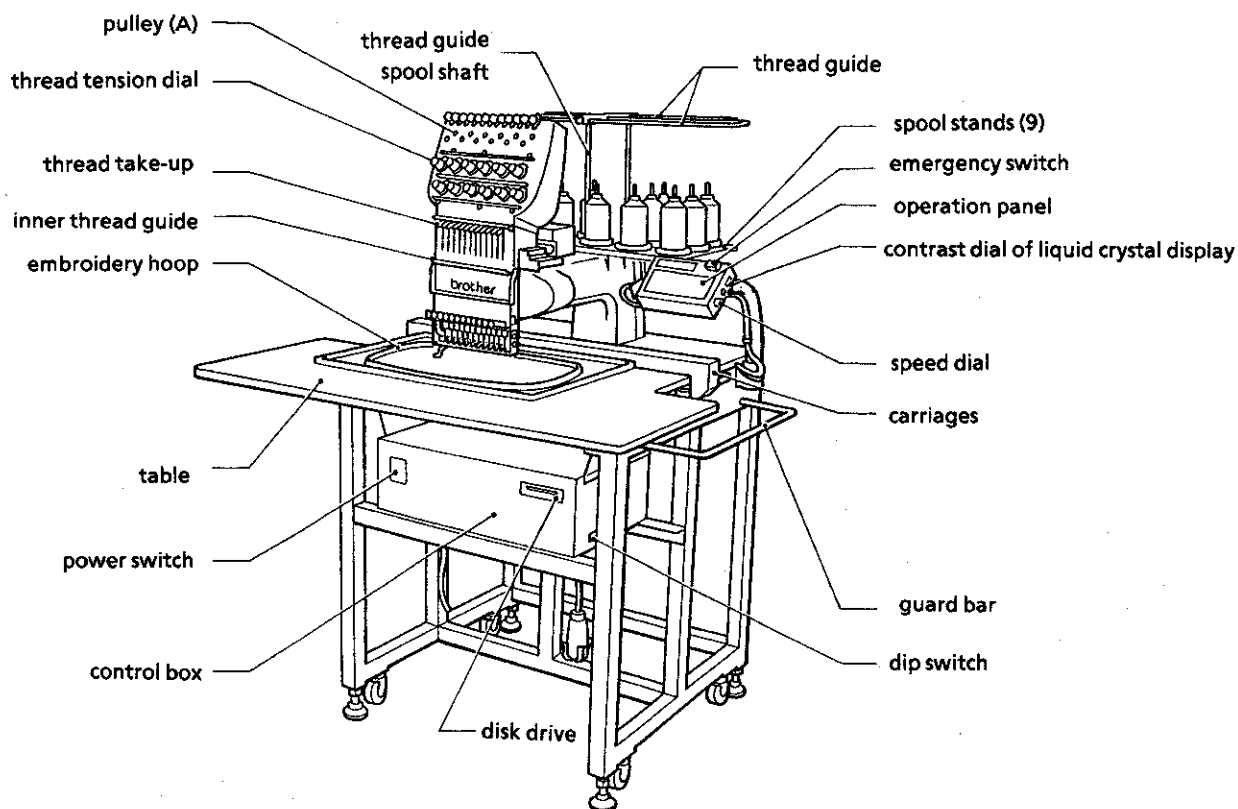



■ BES-1210AC



2. Installation

DANGER

-  Embroidery machines should be installed only by trained engineers.
-  Electric wiring should be laid by your distributor or electric experts.
-  A machine weighs more than 195 kg. Installation should be carried out by 4 or more workers.
-  Do not connect the power source until installation is completed. Doing so may start the machine unintentionally through an accidental activation of the START switch, resulting in bodily injuries.
-  Install a machine in a place away from a highfrequency welding machine or other machines that may generate a strong electric noise. Failure to do so may cause the embroidery machine to malfunction.
-  Establish grounding as designated. Improper grounding may result in an electric shock.

- * After installation is completed, get the power supply from a dedicated outlet.
- * When connecting multiple machines, exercise care not to exceed the capacity of the outlet.

2-1. Transportation of machines

When holding the machine, be sure to hold the machine body (frame).
NOTE: Do NOT hold the table or the guard bar.

2-2. Installation of machines

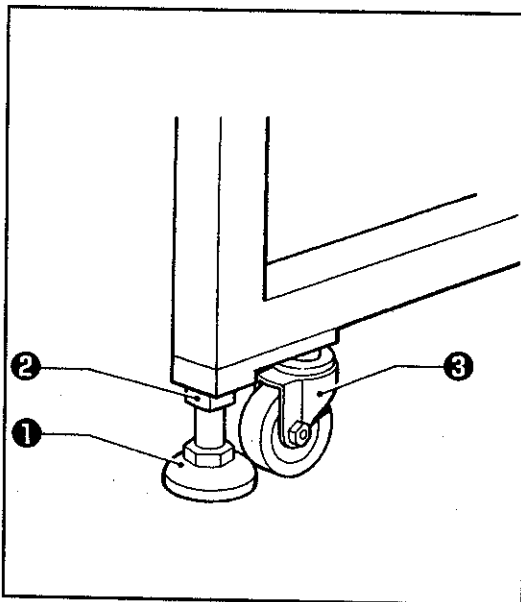

1. Secure the four level adjusters ① so that the upper surface of the table is horizontal.
2. If the table wobbles, loosen the four nuts ② and turn the four level adjusters ① to adjust.

When moving the machine, lift the four level adjusters ① so that the machine can be moved by the casters ③ on the machine body.

2-3. Installation operation panel

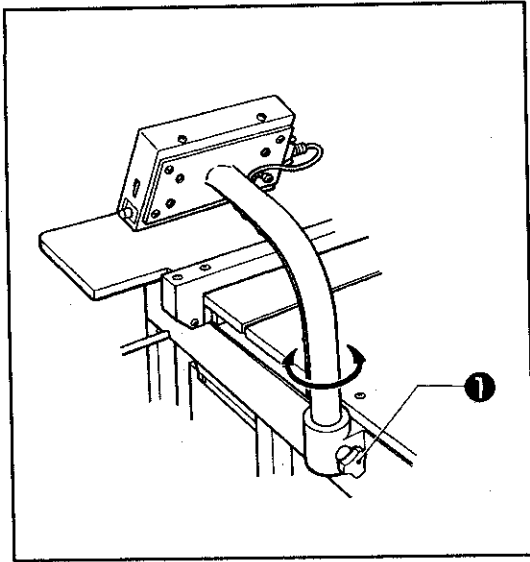

Attach the set screws ❶ so that the panel is in the best position for the operator to use.

2-4. Installing guard bar

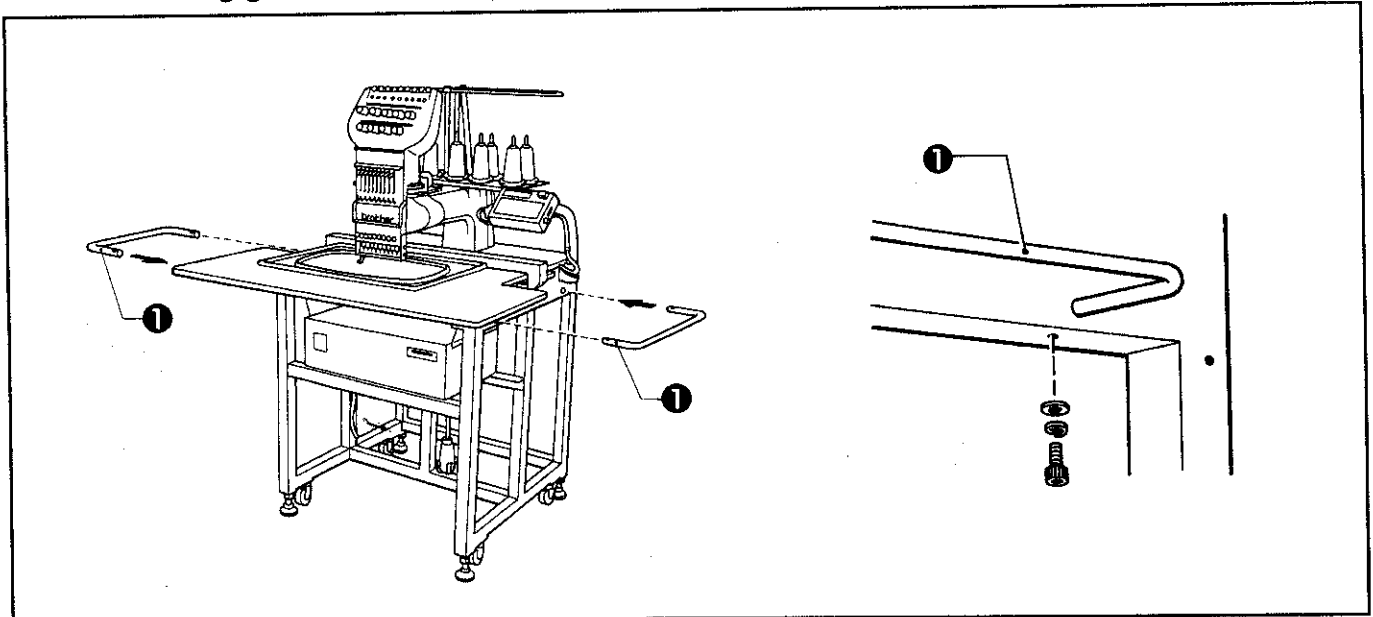

Insert the guard bar ❶ and attach it with the bolt and washer from the bottom side of the frame.

2-5. Power

⚠ DANGER



Establish grounding as designated. Improper grounding may result in an electric shock.

NOTE: Be sure to connect the grounding wire (terminal) when connecting the power supply.

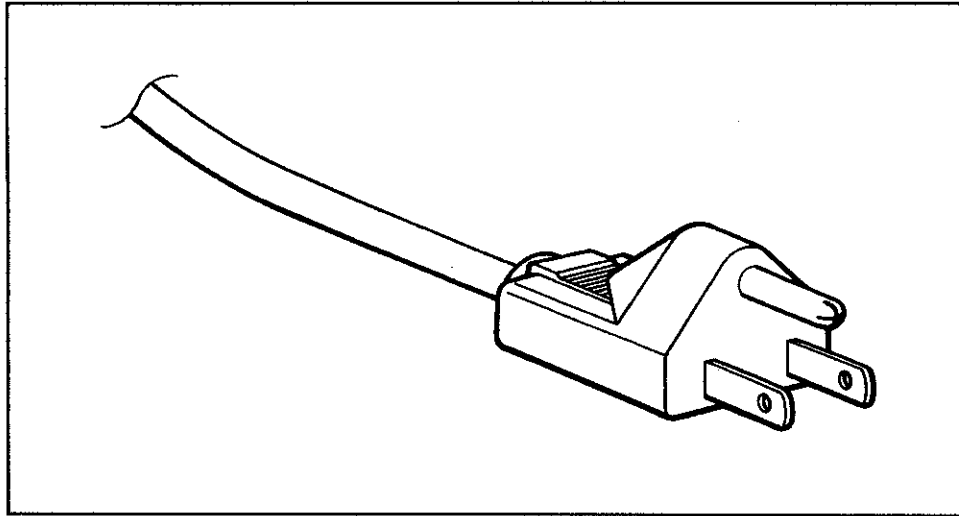

3. Preparation of machine

3-1. Confirm the following before switching on the machine

1. THREAD	2. EMBROIDERY HOOP	3. NEEDLE THREAD POSITION
<ul style="list-style-type: none"> ① The needle thread is set? ② Threading is proper? ③ The needle is threaded? ④ The bobbin thread is set? 	<ul style="list-style-type: none"> ① The embroidery hoop increases the tension of the material? ② The embroidery hoop securely clamps? 	<ul style="list-style-type: none"> ① The needle thread take-ups form a line? ② The needle bar is at its highest position?

■ What is the needle stop position?

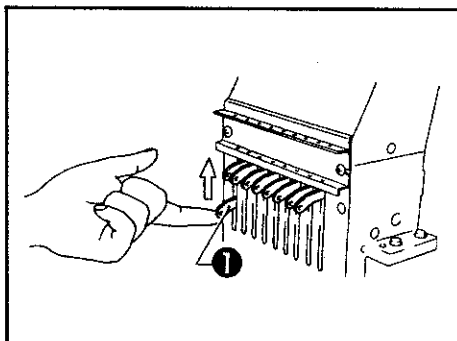

NOTE: When the needle bar and the pulley are not in the stop position or if even one of the needle thread take-ups is not in line, lift the needle thread take-up ① with a finger. The needle thread take-ups form a straight line at the top of the guide plate.
(The illustration at left shows the BAS-416A.)

When the power switch is on, the message, "CAUTION MOVING!" is displayed and the buzzer sounds 'beep'. Then, the embroidery hoop automatically moves to the center of carriages X and Y. At this time, check that there is nothing on the hoop which runs against the point of the needle or the presser foot.

3-2. When turning on the power of the machine

1. If the following are displayed

N_ Case POS. Error
Set NC in order

The machine will beep intermittently, and the message will appear as shown on the left. This message means that the needle bar case is not aligned with the needle hole of the needle plate. The machine cannot operate under this condition.

1. First of all, check that the needle bar stop position is correct.

When the cam plate ② is in its upper position, the machine is in the automatic jump condition. This is the normal position.

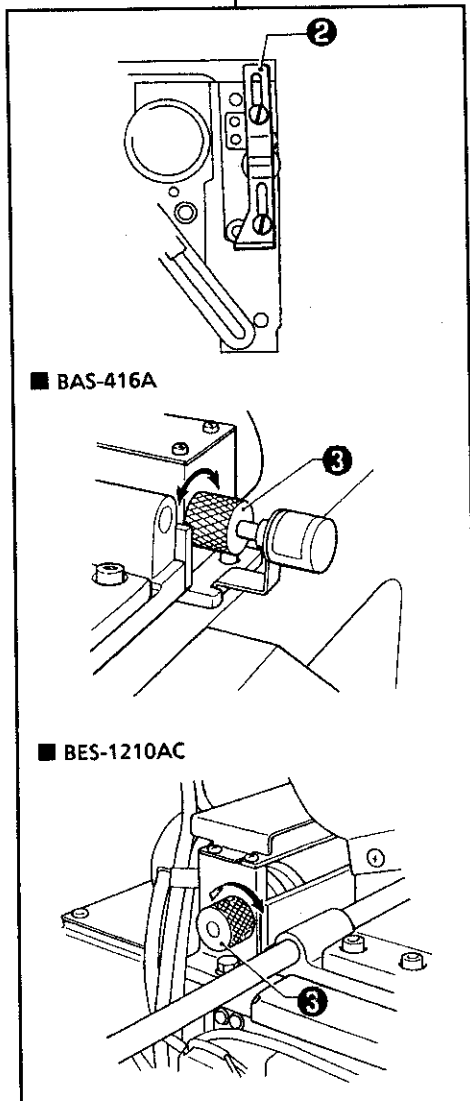

2. Turn the shaft ③ slowly.

If it is unusually hard to turn or does not turn, the needle thread take-up ① or the needle bar is not in the proper position.

Check again and adjust it.

NOTE: Do not turn the shaft forcefully.

CAUTION MOVING!

Press START key

START

3. When the needle bar case comes to the proper position (in the middle of the undetected area where the needle bar case does not move although the shaft ③ is turned), the buzzer sounds 'beep' and the messages, "CAUTION MOVING!" and "Press START key" are displayed alternately.

4. Press the <START> key.

CAUTION MOVING!

File No. 1

Needle POS. Error
Turn Pulley

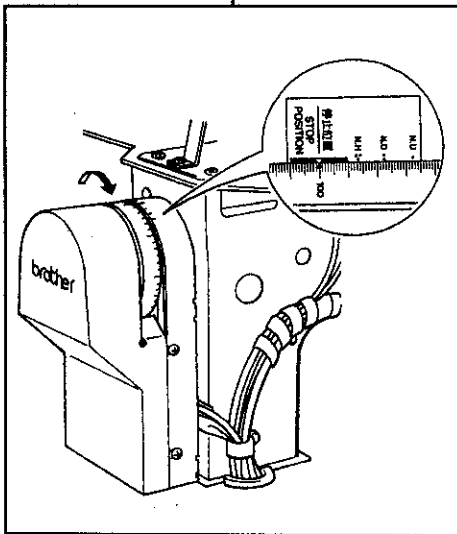

CAUTION MOVING!

Press START key

START

CAUTION MOVING!

File No. 01

The message, "CAUTION MOVING!" will appear along with four beeps, and the X and Y carriages will move to the center of the frame holder base or the same place as when the power was previously turned off.

5. The main menu is displayed.

The needle bar is not in the proper position. Under this condition, it is impossible to move the needle bar to the proper position.

When the needle bar stop position is not proper :

1. Align the 100° mark indicated on the pulley with the stop mark on the belt cover.

2. When the needle bar comes to the proper position, the buzzer sounds 'beep' intermittently, and the messages, "CAUTION MOVING!" and "Press START key" are alternately displayed.

NOTE: Check that the needle bar does not go down.
If it does, set the needle bar in the proper needle bar stop position.
Refer to page 34 "* The proper needle bar stop position".
The mending LED of the first machine head will be lit.

3. Press the <START> key.

The message, "CAUTION MOVING!" will appear along with four beeps, and the X and Y carriages will move to the center of the frame holder base or the same place as when the power was previously turned off.

4. The main menu is displayed.

*** The proper needle bar stop position**

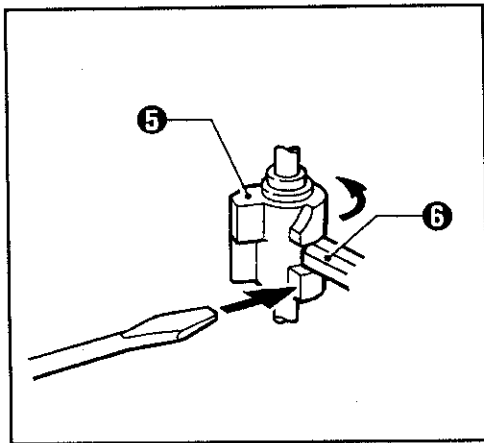
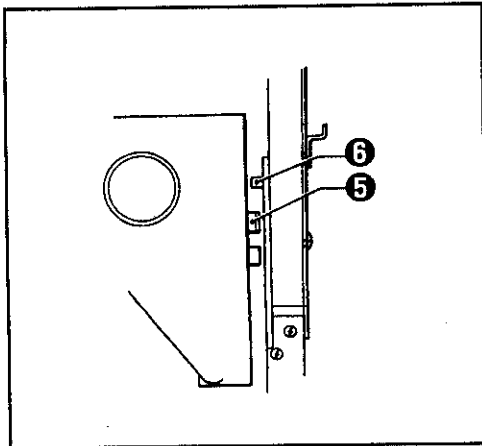

Looking into the inside from the gap, each needle bar is in the jump condition and at its highest point as in the left figure, the needle bar elevating block ⑤ is below so as not to run against the needle bar clamp ⑥.

All the needle thread take-ups are in a horizontal line.

NOTE: Check that the needle bar stop position is proper when turning on the power and when reopening to sew during standstill or pause.

- The needle thread take-ups should form a horizontal line.
- All the needle bars, including the needle bar in the sewing position, should line up at the highest position. If the needle bar in the sewing position is down, it must be disengaged from the needle bar elevating block ⑤ and returned to the highest position. To separate them, insert a screw driver in the gap according to the diagram, then push and rotate.

Once separated, the needle bar moves to the highest point by a spring.

2. If carriages X and Y operate unusually (Clearing and resetting memory)

- When turning on the power not during restarting, carriages X and Y move to an abnormal position after returning to the home position (the center of the embroidery area).
- After having exchanged the P-ROM on the main printed circuit board of the machine. (The power switch should be off in exchanging.)

[Procedures in clearing and and resetting memory]

1. Turn off the power.
2. While pressing the <▽> key, turn on the power. Keep on pressing the <▽> key. Do not release it.
3. When (Memory Clear) (Yes>CLR No>END) is displayed, release the <▽> key and then press the <CLEAR> key.
4. The inside memory storage is reset. Carriages X and Y return to the ordinary operation after turning on the power.

4. Preparation for embroidering

4-1. Replacing bobbin

■ Removing bobbin case

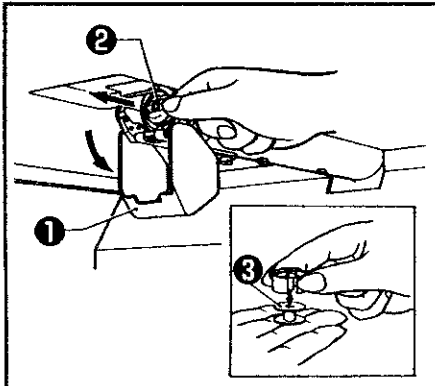

1. Open the rotary hook base cover ①.
2. Hold the knob ② and remove the bobbin case.
3. Close the knob and remove the bobbin ③.

■ Replacing bobbin

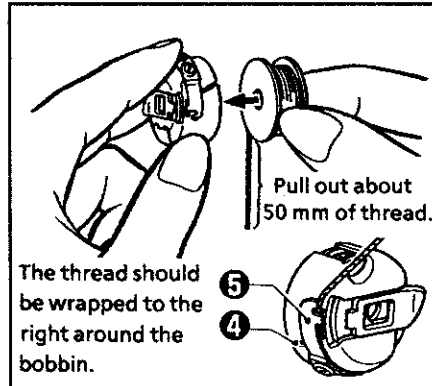

1. Put the bobbin in the bobbin case.
2. Slide the thread under the tension spring ⑤ through the notch ④.
3. Pull out the thread from the hole of the tension spring ⑤ and pass it through the hook ⑥.
4. Pull out the thread about 50mm.

■ Attaching bobbin case

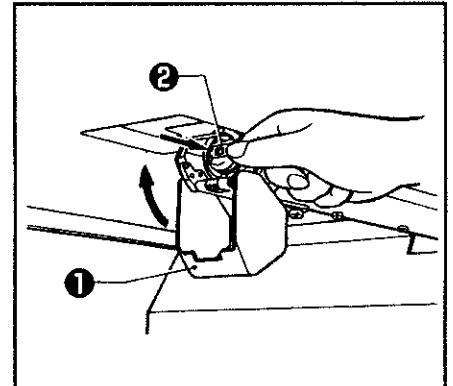

1. Hold the knob ② and attach the bobbin case.
2. Close the cover ①.

4-2. Replacing and selecting needle

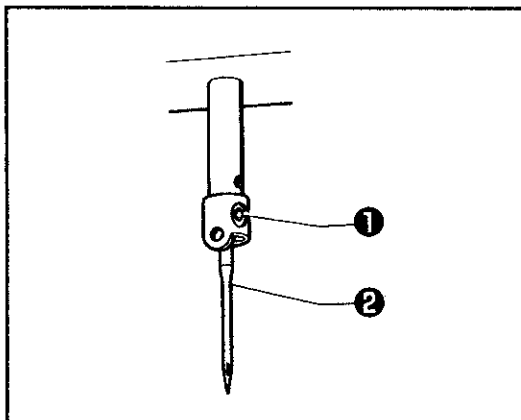

1. Removing needle

Loosen the thumb screw ① and remove the needle ②.

2. Attaching needle

With the flat side facing the front, insert the needle all the way until it meets the end of the needle bar. Tighten the thumb screw ① firmly.

NOTE: Set the needle so that the notched part comes on the rotary hook side.

Materials and needle selection

Fabric type	Needles	Needle numbers
Denim Leather	DB x K5	#14, #16, #18
Handkerchief		#9, #10
Shirt Towel		* #11, #12, #13

The * marks indicate standard parts.

- NOTE:
- When using special threads such as the gold, silver and ramé yarn, use a heavy-duty needle (#11~#16). For better finishing, paste the waxed paper on the back of the material.
 - For general materials, use DB x K5 #11 or #18 according to the thickness of the material. For knitted materials, use DB x K23 #11. Its round end prevents the knit thread from breaking.

4-3. Upper threading

■ BAS-416A

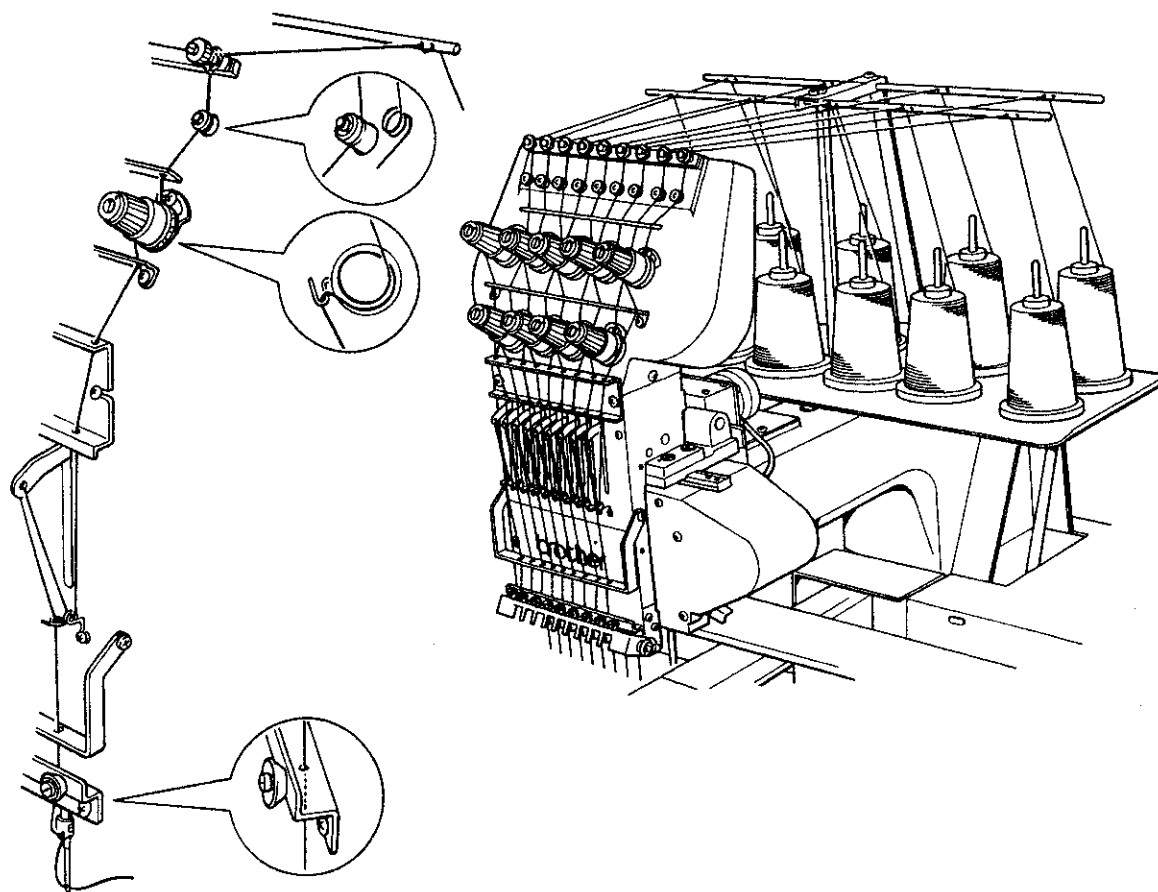

Procedures

1. Pass the thread up through the hole of the thread guide from the stand spool. Then, pass the thread over around and up through the second hole of the thread guide according to the diagram.
2. Pass the thread under the thread guide by lifting it with a finger, and then wind it onto the pulley twice.
3. Pass the thread through the hole of the upper thread guide (U), wind it into the tension disk clockwise once, and place it on the spring.
4. Pass the thread through each hole of the upper thread guide (C) and the thread guide (U) .
5. After passing the thread through the hole of the thread guide (U), insert the thread into the right hole of the inner thread guide, and pass it through the hole of the thread take-up.
6. Bring the thread to the inner thread guide again to insert it into the left hole, and pass it through the hole of the rower thread guide.
7. Pass the thread through the hole of the needle bar thread guide, then pass it through the needle eye without passing it through the presser foot.

■ BES-1210AC

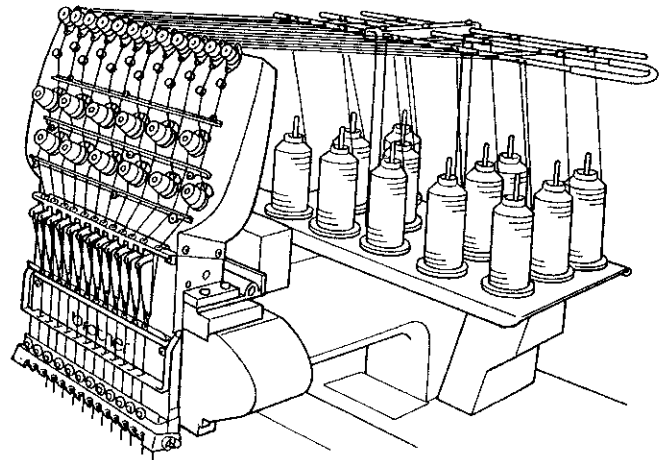
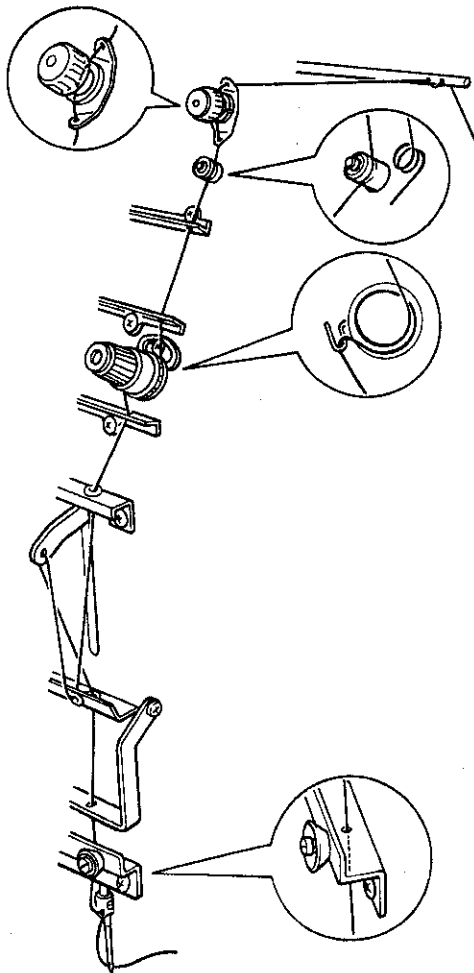

Procedures

1. Pass the upper thread from the cotton stand through the hole of the thread guide right above each cotton stand bar from the lower side.
2. Pass the thread under the thread guide tension disk by lifting it with a finger, and then wind it onto the pulley twice.
3. Pass the thread through the hole of the upper thread guide (U), wind it into the tension disk clockwise once, and place it on the spring.
4. Pass the thread through each hole of the upper thread guide (U) and the thread guide (C).
5. After passing the thread through the hole of the thread guide (U), insert the thread into the right side of the inner thread guide, and pass it through the hole of the thread take-up.
6. Bring the thread to the inner thread guide again to insert it into the hole from the upper section, then into the lower thread guide.
7. Pass the thread through the hole of the needle bar thread guide, then pass it through the needle eye, without passing it through the presser foot.

4-4. Thread tension

■ Needle thread tension

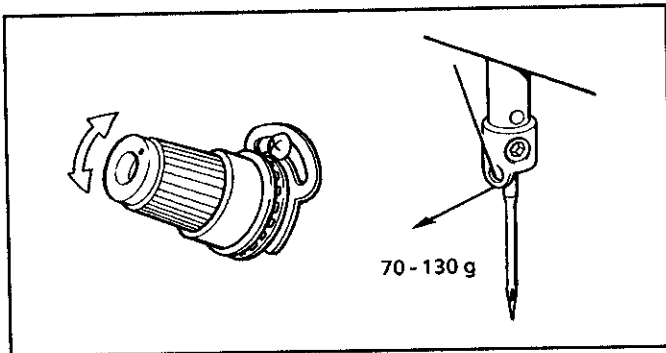

If the needle thread tension is too high, turn the dial counterclockwise.
If the needle thread tension is too low, turn the dial clockwise.

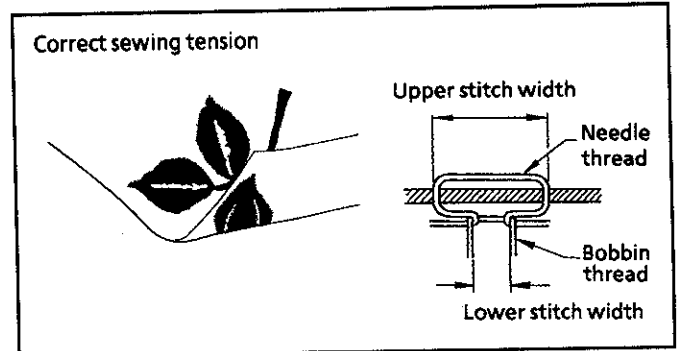

Adjust the tension dial so that the needle thread is pulled to the back of the material, and the lower stitch width is about 1/3 of the upper stitch width.

Adjusting the spring

- * The standard operation range of the thread take-up spring is about 6 - 8 mm. The standard tension at this time is about 0.07 N - 0.12 N (7 gf - 12 gf).
- * To adjust the operation range of the thread take-up spring, loosen the screw ①, and turn the upper thread tension assembly.
- * To adjust the tension of the thread take-up spring, fit a screwdriver into the slot, and turn the tension stud ② as appropriate.

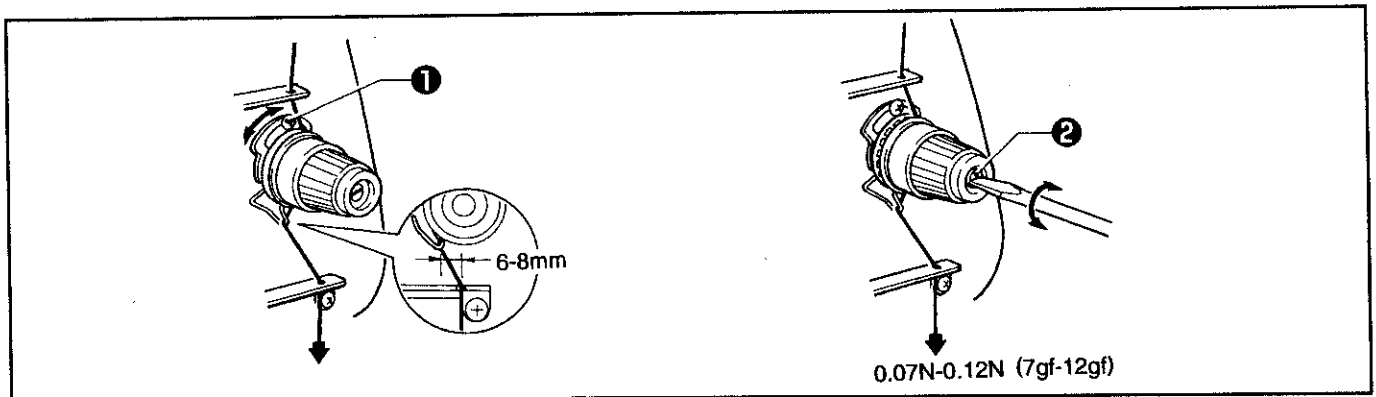

■ Bobbin thread tension

Correct bobbin thread tension (15-25g)

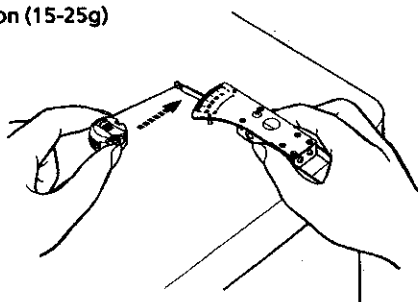

Use a tension gauge to adjust.

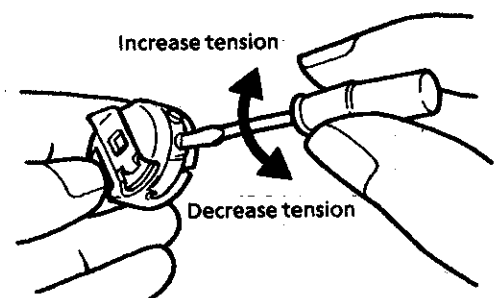

4-5. Attaching embroidery hoop to holder base

- Attaching plastic square hoop to holder base

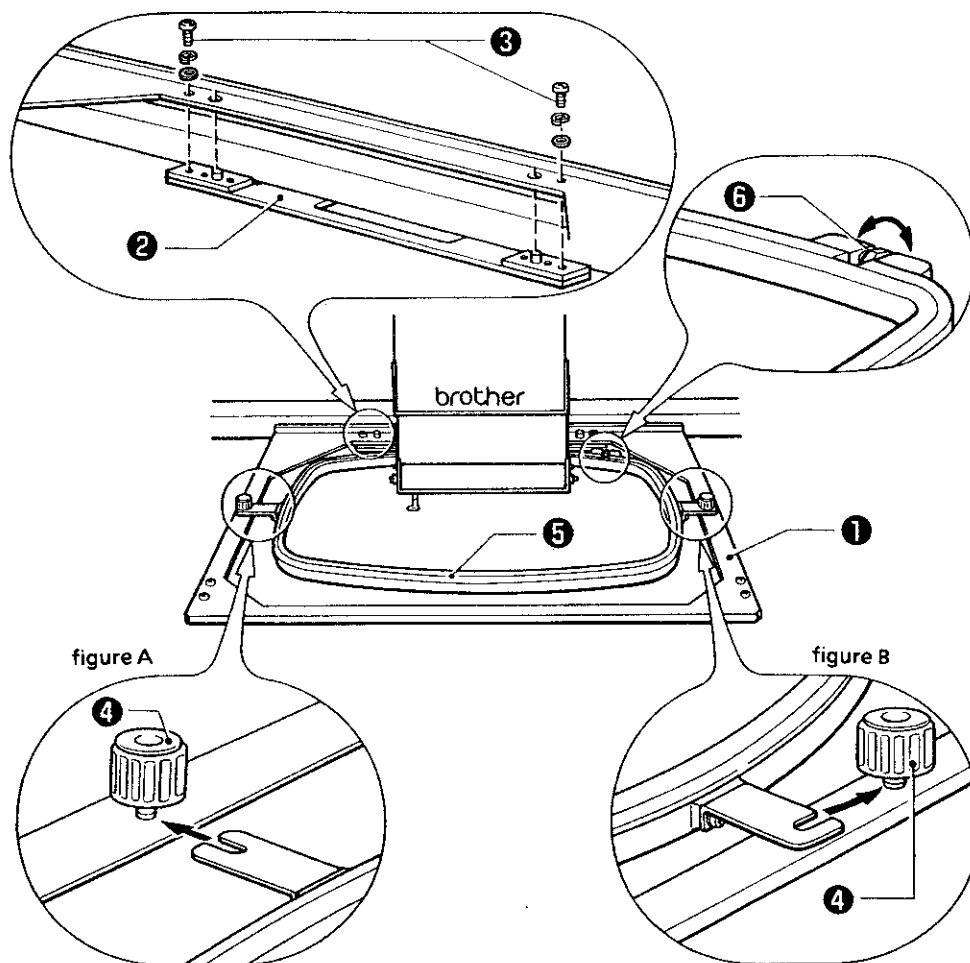

1. Attach the holder base ① to the X carriage ② and tighten the two screws ③. (Fit the protrusions of the X carriage in the holes that are closer to the center.)
2. Loosen the two screws ④ and set the plastic square hoop ⑤.
3. Fix the metal fittings on the left side of the hoop as shown in figure A, and fix the one on the right side of the hoop as shown in figure B. Secure the screws ④.
4. Improper setting of the material in the embroidery hoop may cause skipped stitches, thread breakage, or puckering. Use the screw ⑥ for adjustment.

• Attaching tubular square hoop to holder base (Optional)

NOTE: Before using the tubular square hoop and the holder base, remove table (C) of the embroidery machine.

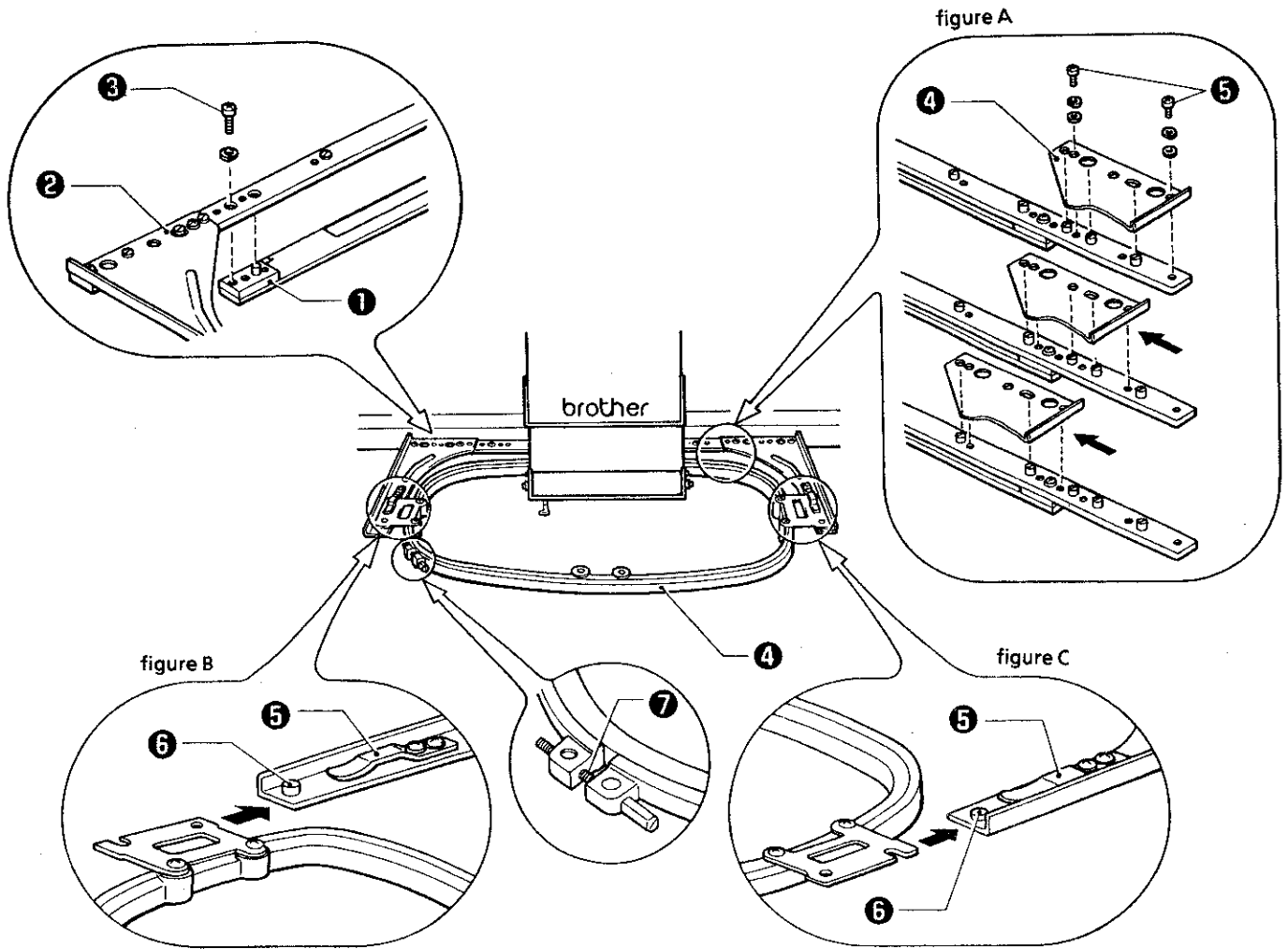

1. Attach the tubular frame set ② to the X carriage ① with the two screws ③.
(Fit the protrusions ⑥ of the X carriage in the holes that are closer to the center.)
2. Attach the metal fittings of the tubular square hoop ④ as shown in figures B and C.
When attaching them, lift the plate spring ⑤ slightly and be sure to fit the protrusions ⑥ of the holder base in the holes of the frame.
3. Improper setting of the material in the embroidery hoop may cause skipped stitches, thread breakage or puckering. Use the screw ⑦ for adjustment.
4. Remove the screws ⑤ shown in figure A and then adjust the positions of the left and right arms of the tubular frame ② according to the angle of the embroidery hoop. After adjusting, tighten the screws ⑤.
NOTE: Install the right and left arms of the tubular frame ② so that they are symmetrical with respect to each other.

• Attaching sashes frame set (Option)

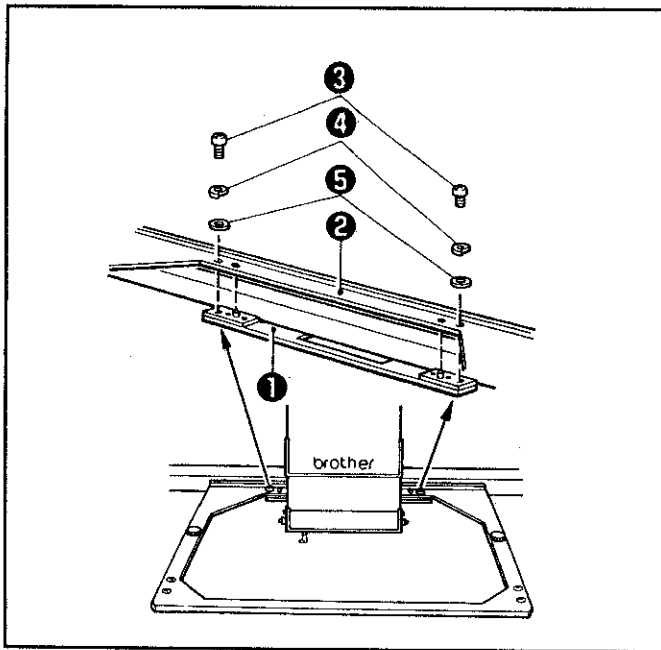

1. Turn off the power.
2. Pull the carriages X ① outward toward you. Loosen the two screws ③, and remove the holder base assembly ② and the spring washers ④ plain washers ⑤ from the carriages X ①.
NOTE: The two screws and spring washers and plain washers removed in this step will be used later. Do not lose them.

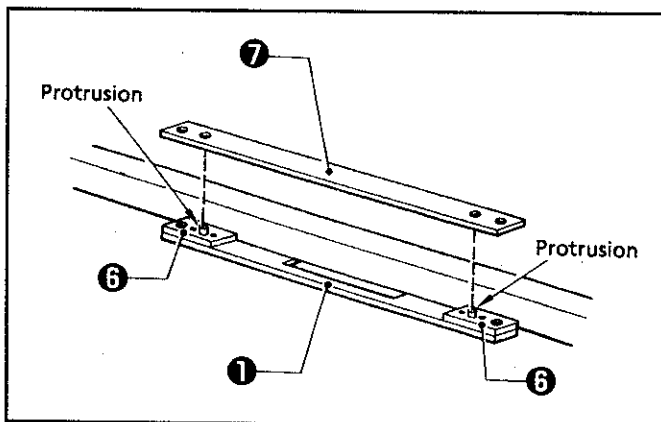

3. Fit the spacer ⑦ in the protrusion of the frame plate assembly ⑥ attached to the carriages X ①.

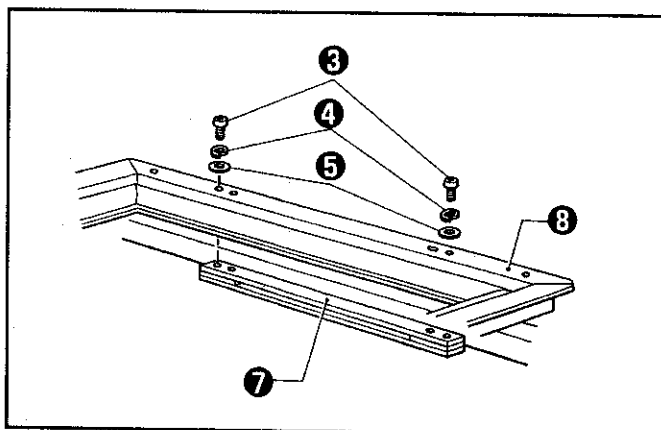

4. Similarly, secure the sashes frame set ⑧ with the screws ③, the spring washers ④, and the plain washers ⑤.
NOTE: When installing the order frame, install it so that the side which has felt attached to the underside is facing toward you.

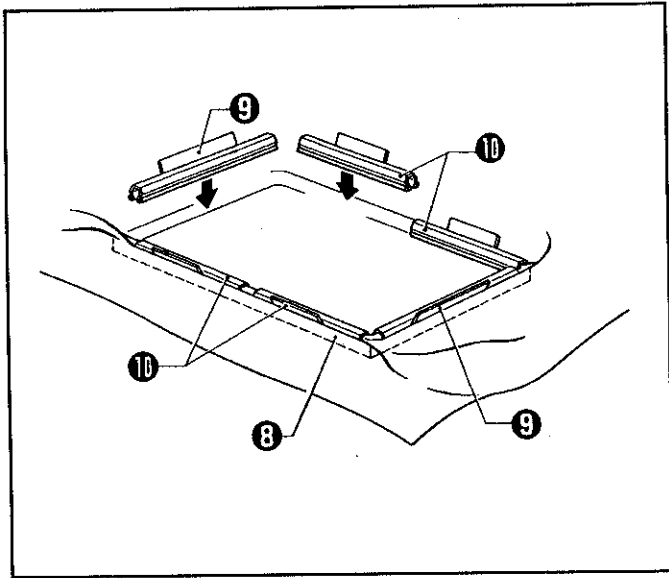

- Put the material on the sashes frame set ⑧ and attach the two 290 clips ⑨ on both sides of the home position frame. Then attach each of the two 220 clips ⑩ on the upper and lower sides of the sashes frame set.
- When the sashes frame set is used, the sewing area will be 300 mm vertically x 450 mm horizontally.

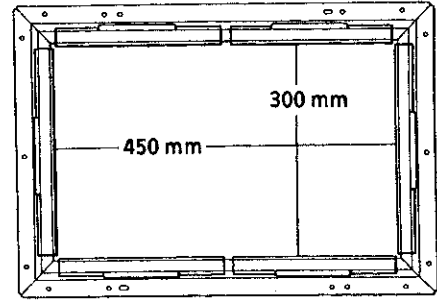

F01: G001 . DST
STAFF / Disk

START

Set STR P. Co. 0 4
N_No. 1 2 3 4

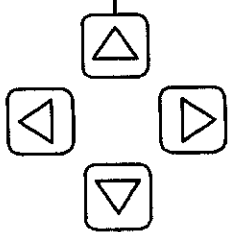

Set STR P. Co. 0 4
N_No. 1 2 3 4

START

F 0 1 STAFF
N_No. 1 2 3 4

EMERGENCY

R St: 0 1 5 3 9 8 Co: 0 4
N_No. 3 4

CLEAR

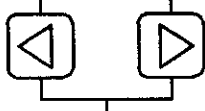

Moving the hoop forward or backward can be done by 1 stitch increment with <<> key and <>> key.

#

If the <#> key is pressed twice, moving the hoop backward or forward can be done in 100 stitch increments.

※ When [] is displayed, embroidering can be performed for individual colors.

※ When [] is displayed, embroidering program is returned to its start of the current embroidery data.



Sewing is cancelled. Return to step 8.

R St: 0 1 5 2 9 8 Co: 0 4
N_No. 3 4

R St: 0 1 5 0 9 8 Co: 0 4
N_No. 3 4 []

When reading data is finished, its pattern name (STAFF) is displayed on the lower row of the display.

7. Press the <START> key to enter the sewing mode.

8. Move the hoop to set sewing start point with the <Δ>, <<>, <▽> and <▷> keys.

9. Press the <START> key to start sewing.

10. If the <EMERGENCY> key is pressed, sewing is suspended.

R St: 0 1 5 2 9 8 Co: 0 4
N No. 3 4

START

F 0 1 STAFF
N No. 3 4

Thread breakage

Thread breakage
Press END key

END

R St: 0 0 5 2 9 8 Co: 0 4
N No. 4

#

R St: 0 0 5 2 9 8 Co: 0 4
N No. 4

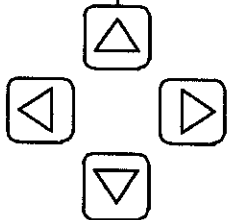

R St: 0 0 5 2 9 8 Co: 0 4
N No. 4

START

F 0 1 STAFF
N No. 3 4

Set STR P. Co: 0 4
N No. 1 2 3 4

11. Press the <START> key. Sewing will resume.

12. If thread breakage occurs, sewing is suspended and the error message is displayed.
NOTE: Pass the thread again.

13. Press the <END> key. The error is cancelled and the machine suspends.

When the hoop is moved forcibly

14. Press the <#> key four times. The hoop can then be force-moved.

15. By pressing the <△>, <◁>, <▽> or <▷> key, the hoop is moved in the direction of pressed key by 0.1 mm increment.

NOTE: • When the hoop is moved forcibly, sewing left unperformed will slip for its hoop movement distance. Pay attention to this usage.
• If the hoop and the material do not match properly, correction can be done by pressing the <▷>, <△>, <◁>, and <▽> keys.

16. Press the <START> key. Sewing will resume.

17. After sewing is completed, the machine will return to step 8.

F01: G 0 0 2 . DST
Clover / Disk

EDIT

F01: G 0 0 2 . DST
(1) Rotation ↓

▽

▽

F01: G 0 0 2 . DST
(3) Repeat ↓

EDIT

Repeat : H 1 Time
Space : 000 mm

Repeat : H 3 Times
Space : 005 mm

END

F01: G 0 0 2 . DST
(3) Repeat ↓

START

Set STR P. Co. 0 6
N_ No. 1 2 3 4 5 6

△

◀

▶

▽

When reading data is finished, its pattern name (Clover) is displayed on the lower row of the display.

7. Press the <EDIT> key to enter the editing mode.
8. Press the <▽> key twice to select the repeat sewing setting mode.
9. Press the <EDIT> key to enter the repeat sewing setting mode.
10. Set value referring to page 56 "Setting repeat sewing".
11. Press the <END> key to exit from the repeat sewing setting mode.
12. Press the <START> key to enter the sewing mode.
13. Move the hoop to set the sewing start point with the <△>, <◀>, <▽>, and the <▶> keys.

Set STR P. Co. 0 6
N No. 1 2 3 4 5 6

START

F01: Clover 1/3
N No. 1 2 3 4 5 6

EMERGENCY

R St: 0 0 0 3 9 8 Co: 0 6
N No. 3 4 5 6

END

R St: 0 0 0 6 5 2 Co: 0 6
N No. 1 2 3 4 5 6

START

F01: Clover 2/3
N No. 3 4

EMERGENCY

R St: 0 0 0 3 9 8 Co: 0 6
N No. 3 4 5 6

CLEAR

Set STR P. Co. 0 4
N No. 1 2 3 4

14. Press the <START> key to start sewing.

15. If the <EMERGENCY> key is pressed, sewing is suspended.







16. Press the <END> key. Sewing the first pattern will be cancelled and the machine will be ready for sewing the second repeated pattern.



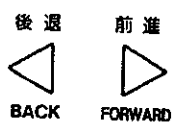
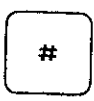

17. Press the <START> key. Sewing will start.

18. If the <EMERGENCY> key is pressed, sewing is suspended.

19. When the <CLEAR> key is pressed, all the repeat sewing is canceled. The machine will return to step 13 and be ready for sewing the first pattern.

■ The following keys are available in the sewing mode:

Available key	Function
	<ul style="list-style-type: none"> • To move hoop in setting sewing start point • Inch hoop by 0.1 mm in inching mode when sewing is suspended
	<ul style="list-style-type: none"> • To move hoop in setting sewing start point • Move hoop back or forward by 1 stitch or 100 stitches at a time when sewing is suspended • Inch hoop by 0.1 mm in inching mode when sewing is suspended
	<ul style="list-style-type: none"> • This is invalid in setting sewing start point • To switch inching mode or jump mode when sewing is suspended. When this key is pressed four times, the machine switches to inching mode. If the key is pressed 1 - 3 times, the machine switches to jump mode.
	<ul style="list-style-type: none"> • To trace mask line of pattern in setting sewing start point • To check set values of a pattern when sewing is suspended
	<ul style="list-style-type: none"> • This is invalid in setting sewing start point • To cancel sewing when sewing is suspended and to clear error message
	<ul style="list-style-type: none"> • To enter editing mode in setting sewing start point • This is invalid when sewing is suspended
	<ul style="list-style-type: none"> • To enter data entry mode in setting sewing start point • This is invalid when sewing is suspended
	<p>To start sewing</p>
	<ul style="list-style-type: none"> • To return to main menu in setting sewing start point • To cancel current sewing pattern when repeat sewing is suspended

Available key	Function
	To enter needle bar setting mode
	To enter needle bar selecting mode
	To enter thread breakage sensor and bobbin thread counter setting mode
	To trim thread
	To feed hoop or enter hoop feed mode

3. Restarting

In the following cases, sewing can be resumed.

When the power of the machine is cut off because of a power loss during sewing, or if the power switch is turned on after having been turned off during suspension or sewing:

Turning off the power : When the machine is suspended during sewing.
 After the <EMERGENCY> key has been pressed.
 When the machine is automatically suspended because of needle thread breakage, and so on.

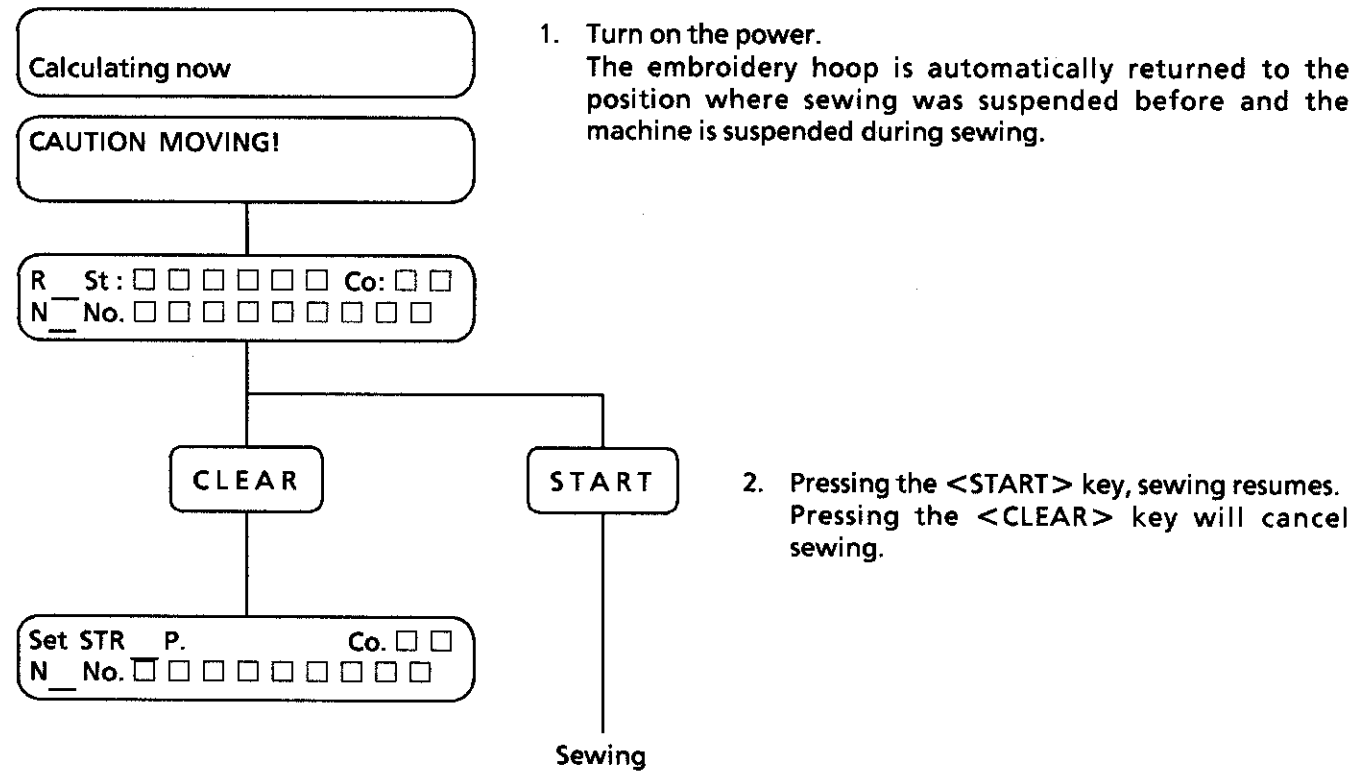

1. Turn on the power.
 The embroidery hoop is automatically returned to the position where sewing was suspended before and the machine is suspended during sewing.

2. Pressing the <START> key, sewing resumes.
 Pressing the <CLEAR> key will cancel sewing.

In case the power of the machine was cut off because of a power loss

Restart > START
Sew. Cancel > END

1. Turn on the power.
The messages, "Restart" and "Sew. Cancel" are displayed.

START END

2. Pressing the <START> key, sewing resumes.
Pressing the <END> key will cancel sewing and return to main menu.

Sewing

CAUTION MOVING!

FileNo.01
* [E] * * * [D] * * *

NOTE: In (1) and (2), if more than a day passed with the power off, the memory will be erased and the restart cannot be done.
Turning on the power will display the main menu.

Chapter 4. Embroidering Procedures

1. Flow chart

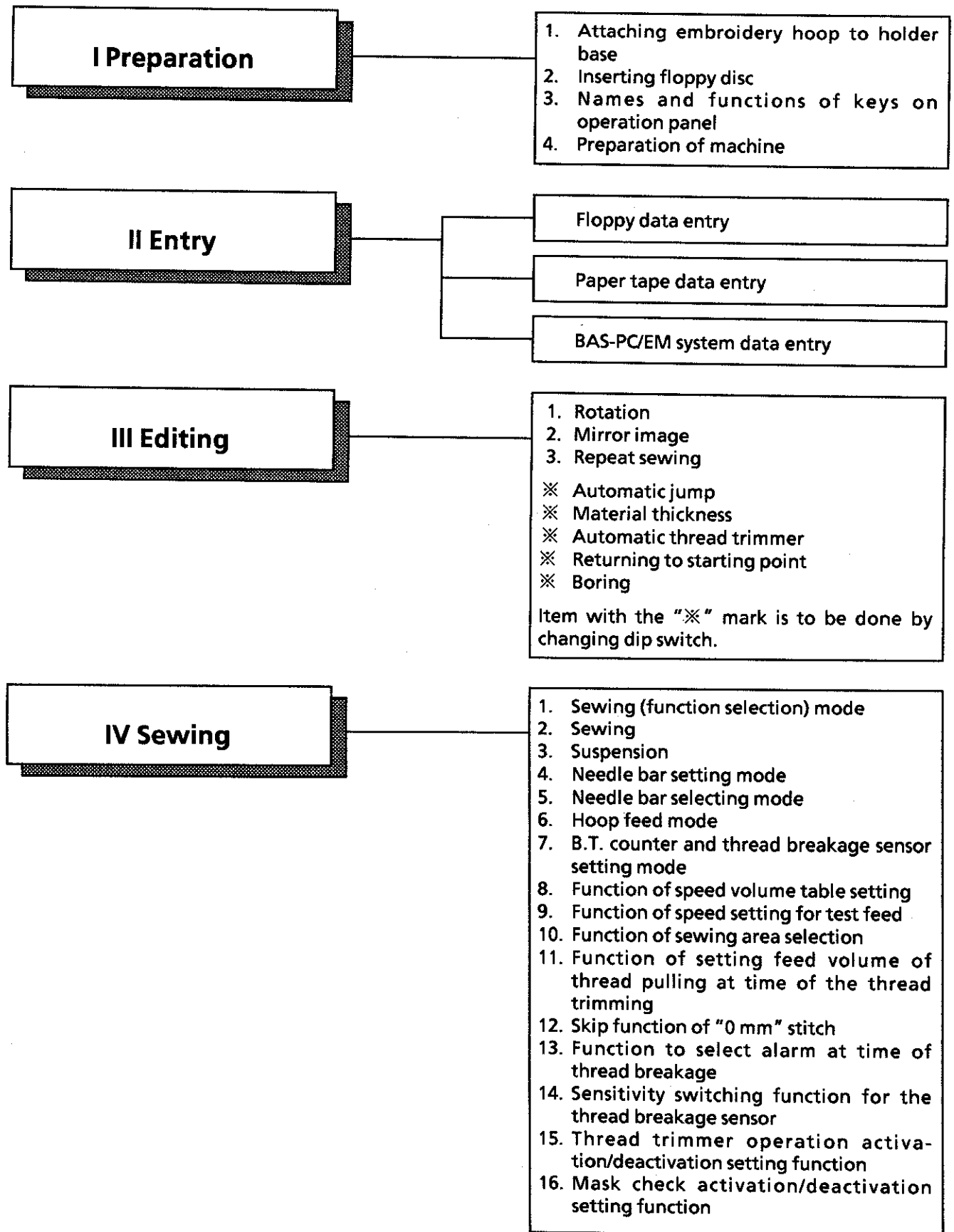

2. Inserting floppy disk

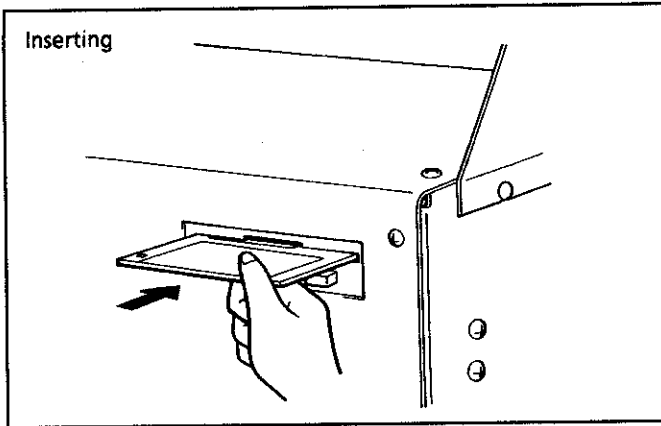

- NOTE :**
- If the floppy disk is not properly inserted, the data will not be read.
 - Keep the floppy disk away from magnets and televisions, for the data on the disk can be damaged by magnetism.
 - Insert the floppy disk into the disk drive with the label facing upward.
(Insert it until it clicks into place.)

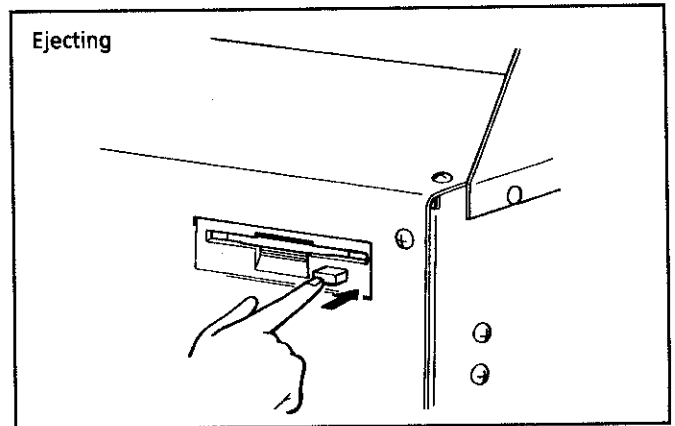

Press the eject button to take out the floppy disk.
Do not eject the disk while the drive indicator is on.

3. Names and functions of operation panel

3-1. Names

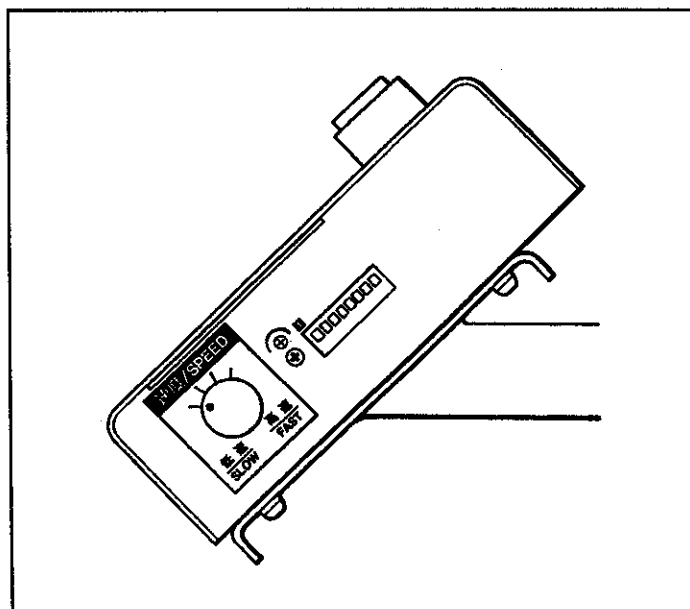
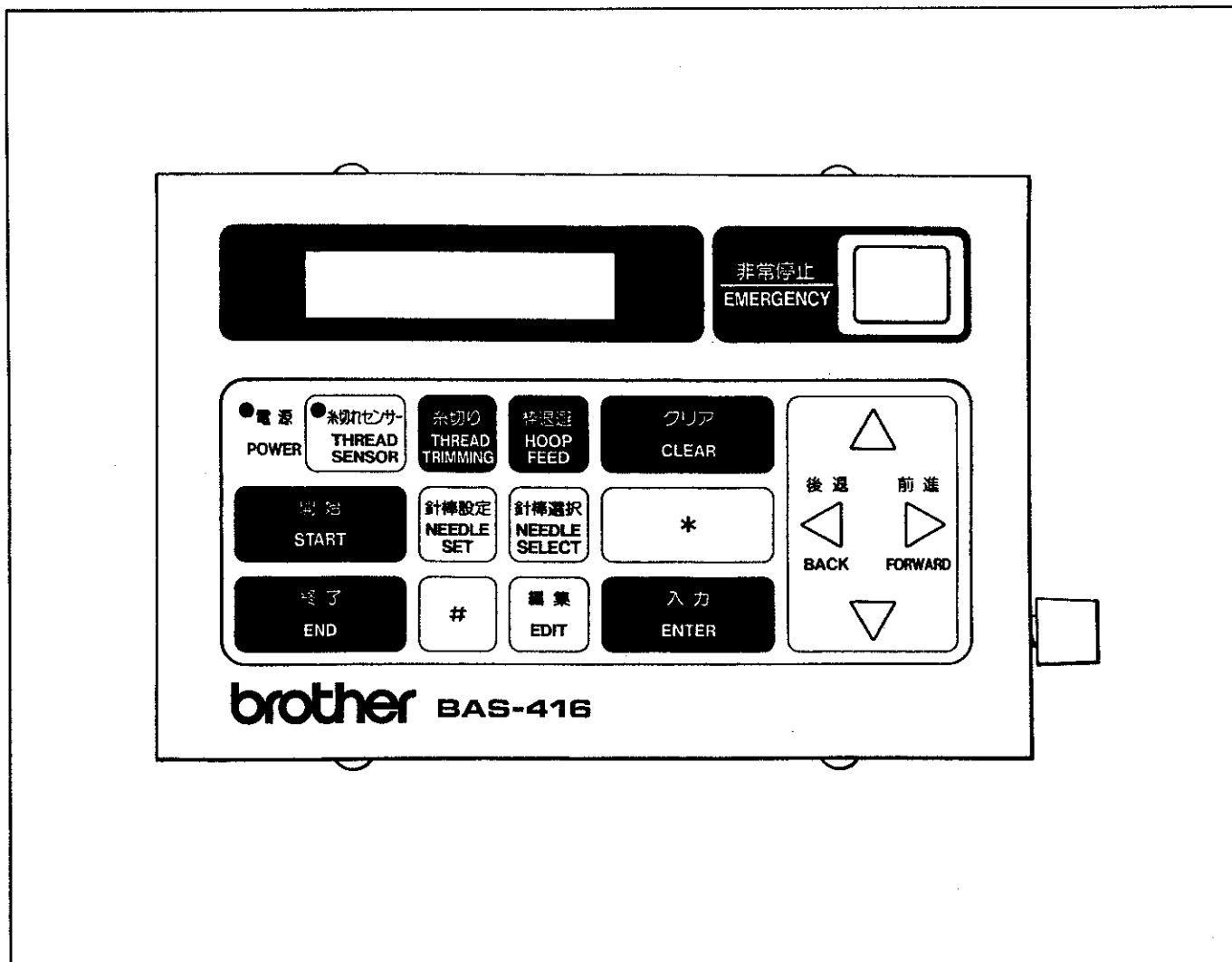

3-2. Functions of keys on operation panel



Use this key to;

- Embroider the data stored in just the state it was in last embroidered.
- Restart in the sewing mode during suspension.
- Start after the carriage moved to sewing start point.



Use this key to;

- Exit from each mode after floppy disk data entry, paper tape data entry or editing system data entry.
- Exit from the editing menu (after setting rotation, mirror or repeat sewing) and to exit from editing mode.
- Exit from the needle bar setting mode and needle bar selecting mode.
- Exit from setting THREAD SENSOR or bobbin thread counter.
- Exit from the sewing mode.
- Cancel error during sewing.



Use this key to;

- Enter data entry mode (from floppy disk, paper tape reader, editing system).
- Read a pattern data of file name displayed on the upper row from floppy disk, paper tape reader or editing system. (This is invalid when data is already registered in selecting number.)
- Enter current needle location as hoop feed point and to display its coordinates.
- If data is not registered, read pattern data of the file name displayed on the upper row from floppy disk, paper tape reader, or BAS-PC/EM and to start automatic sewing.
- Decide automatic stop in setting needle bar or not. ("S" (set) mark is displayed alternately.)



Use this key to;

- Clear file data displayed on the upper row and the screen.
- Cancel error.
- Return set values of the registered number displayed on the upper row to default.
- Return selecting needle number to default value.
- Set hoop feed point in the center of the area in hoop feed mode.
- Change current counter number to set value in setting bobbin thread counter.

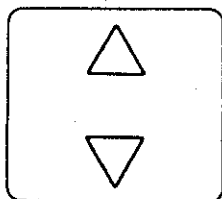

Use this key to;

- Scroll file names registered in floppy disk or editing system.
- Select paper tape type (from Tajima, Barudan, Zangs).
- Scroll editing menu items.
- Set repeat times and space length in setting repeat sewing.
(In For the BAS-416A, the setting will scroll through the numbers 1 to 9; for the BES-1210AC, the setting will scroll through the numbers 1 to 9 and the letters A to C.)
- Select needle number in needle bar setting mode or to enter set times in bobbin thread counter setting mode.
(In For the BAS-416A, the setting will scroll through the numbers 1 to 9; for the BES-1210AC, the setting will scroll through the numbers 1 to 9 and the letters A to C.)
- Move needle location to the desired hoop feed point.
- Feed hoop just after entering sewing mode.
(This is invalid in sewing mode during suspension.)
- Inch hoop to the desired position by 0.1 mm in inching mode.
- Clear the machine memory <▽>

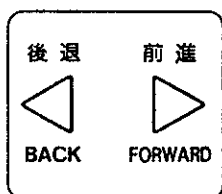

Use this key to;

- Change the cursor position on the number in setting bobbin thread counter.
- Move needle location to the desired hoop feed point.
- Select the needle bar shift direction toward no.1 or no.9 in selecting needle bar.
- Select color order in selecting needle bar.
- Move hoop after entering the sewing mode and to move hoop back or forward along stitch line on data when sewing is suspended.
- Inch hoop to the desired position by 0.1 mm in inching mode.
- Change the cursor position on the number in setting repeat sewing.
- Decide mirror image (Image J → L · 「 → 1) and rotation angle (0° → 90° · 180° → 270°).
- Select registered number of input data from floppy disk, paper tape or BAS-PC/EM.



Use this key to;

- Edit in main menu.
- Edit after data input from floppy disk, paper tape or editing system.



Use this key to set needle order after reading data in each mode (main menu mode, floppy disk data entry mode, paper tape data entry mode, editing system data entry mode) and entering sewing mode.



Use this key to enter thread sensor and bobbin thread counter setting mode from each mode (main menu mode, floppy disk data entry mode, paper tape data entry mode, editing system data entry mode).

- * When THREAD SENSOR is ON, the left upper indicator will light. (Setting ON and OFF can be done cyclically.)



Use this key to;

- Enter test mode from main menu mode.
- Display pattern name of the file name displayed on the upper row when data is entered from floppy disk or editing system.
- Check set values of registered number that was selected on the upper row in editing menu or to check set values of sewing data in sewing mode.



Use this key to:

- Enter hoop feed mode from each mode (main menu mode, floppy disk data entry mode, paper tape data entry mode, editing system data entry mode, sewing mode after selecting editing menu).
- Exit from this mode after returning from hoop feed point in hoop feed mode.



Use this key to select needle bar in each mode; main menu mode, floppy data entry mode, paper tape data entry mode, editing system data entry mode, sewing mode after selecting editing menu.



Use this key to trim thread regardless of sewing.

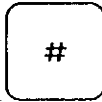

Use this key to;

- Select registered data number and to switch hoop feed mode.
 - * Mode changing can be done repeatedly.
- Enter paper tape data reading mode in setting floppy data entry.
- Enter editing system data reading mode in setting paper tape data entry.
- Enter floppy disk data reading mode in setting editing system data entry.
- Decide repeat direction (either vertical or horizontal) in setting repeat sewing.
 - * "V" (vertical direction) and "H" (horizontal direction) are alternately displayed.
- Perform trial feeding just after entering sewing mode.
- Enter inching mode or jump mode in sewing suspension.
- Set needle select number as long as the receive data from editing system is entered.
 - [NOTE] For floppy disk data and paper tape data, this key is invalid.
- Decide automatic hoop feed after sewing mode or not.
 - * "[S]" (set) mark is displayed alternately.



Use this key to;

- Stop the machine during sewing.

3-3. LED lamp

- Power lamp (green)
This indicator is lit when the power is turned on.
- THREAD SENSOR ON/OFF (red)
This indicator is lit when the thread sensor operates.

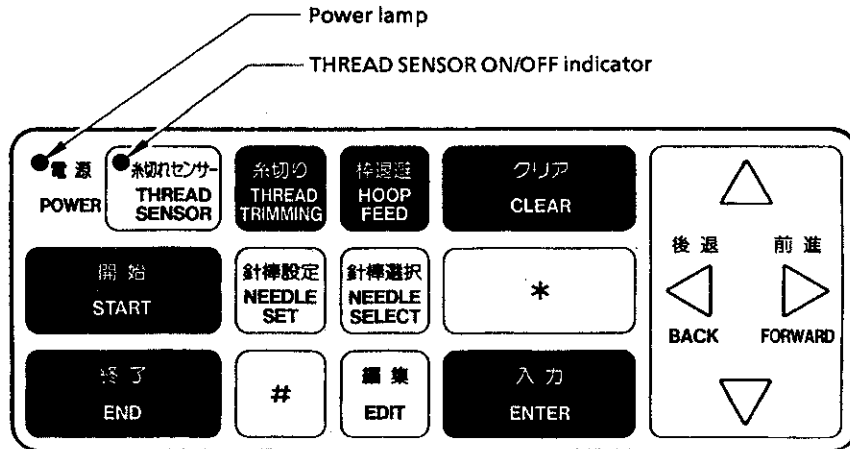

3-4. Operation panel display



The operation step, data registered number (with file name), editing information and error messages are displayed here.
One line has 16 letters and up to two lines can be displayed.

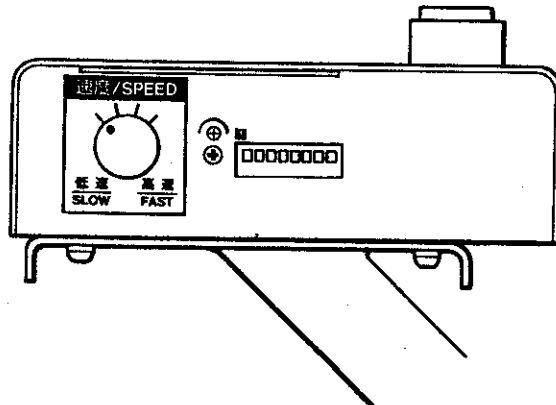

The speed dial is used to select one of the 4 sewing speeds, according to the chart below.

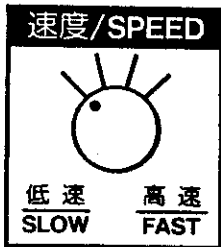

The contrast dial of liquid crystal display is used to adjust the darkness of the display.



4. Dip switch functions

4-1. Dip switch functions on main printed circuit board

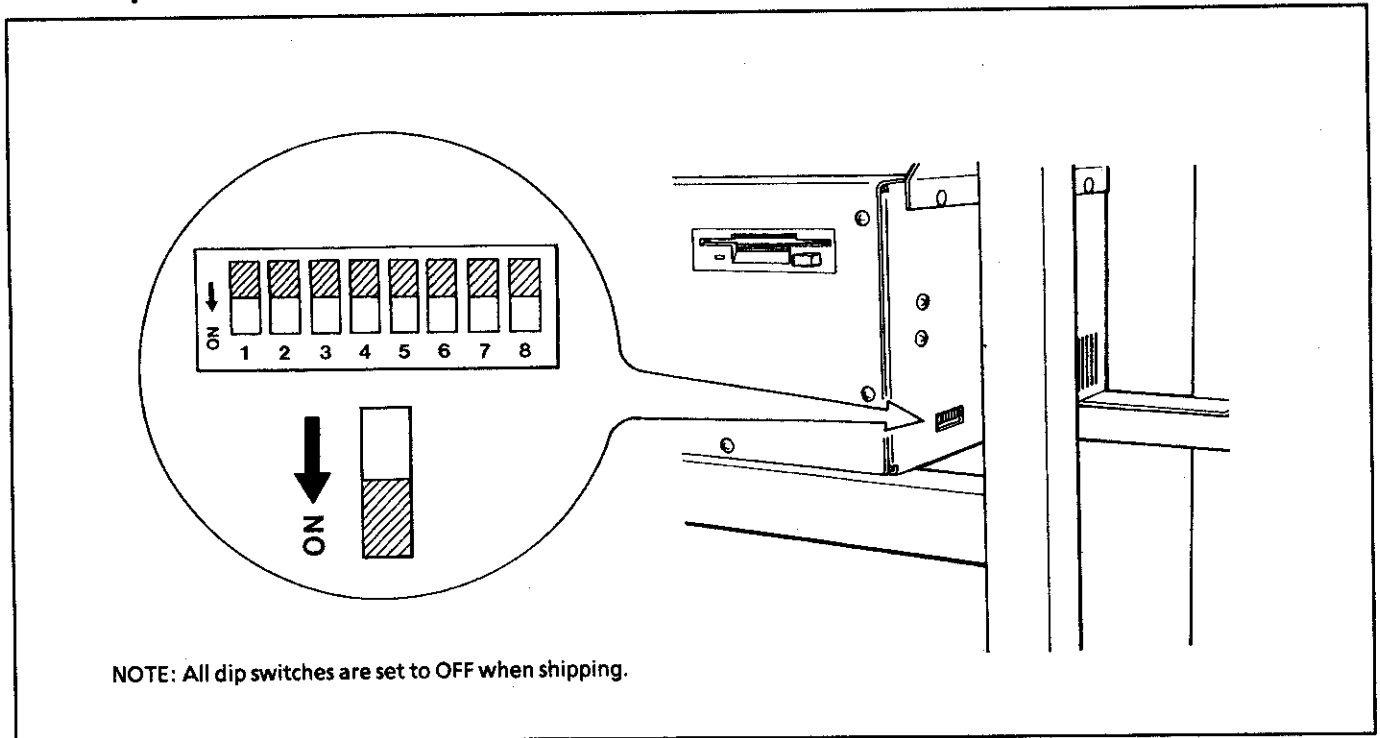

switch number	state	function
SW1	OFF	To set the communication speed for the tape reader or editing system to 9600 bps (The speed can be set to 38400 bps when SW7 is ON)
	ON	To set the communication speed for the tape reader or editing system to 4800 bps (The speed can be set to 19600 bps when SW7 is ON)
SW2	OFF	To store data of floppy disk in the memory
	ON	To read and sew data of floppy disk (Data cannot be stored in the memory.)
SW3	OFF	Even if another floppy disk is inserted during data reading or sewing of a character (pattern), machine will continue reading or sewing until it is done.
	ON	If another floppy disk is inserted during data reading or sewing of a pattern (character), machine will stop operation at that point.
SW4	OFF	To display the hoop name for the embroidery data while embroidering
	ON	To display the embroidering speed while embroidering
SW5	OFF	To set normal power mode
	ON	To set Power Up hoop feed mode
SW6	OFF	To set inching after thread trimming
	ON	To cancel inching after thread trimming
SW7	OFF	Use in conjunction with SW1
	ON	
SW8	OFF	To display Japanese
	ON	To display English

- NOTE:
- The power of the machine should be turned off before changing switch. If the power is not turned off, functions do not change.
 - Do not take out the floppy disk from the floppy disk drive during data reading and sewing. It may occur errors or hinder correct sewing.

4-2. Dip switch functions on operation panel

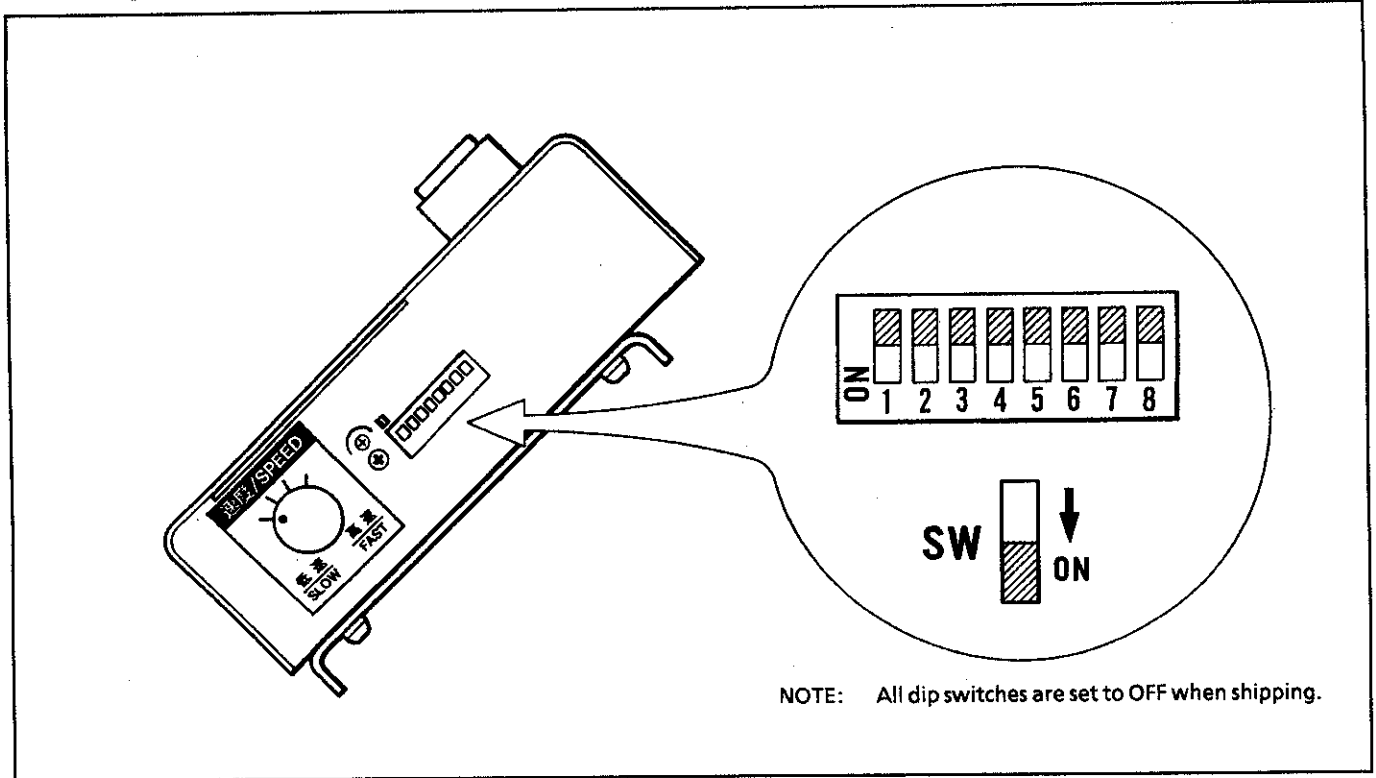

switch number	state	function			
SW1		To jump stitch after thread trimming	SW1	SW2	
SW2			more than 8 stitches	OFF	OFF
			more than 5 stitches	ON	OFF
			more than 3 stitches	OFF	ON
		without thread trimming	ON	ON	
SW3	OFF	Not available (Should be set to OFF)			
	ON				
SW4	OFF	Not available (Should be set to OFF)			
	ON				
SW5	OFF	To return to sewing start point after sewing			
	ON	Not to return to sewing start point after sewing			
SW6	OFF	To adjust timing of hoop movement and needle rise for thin material (The maximum sewing speed is 1200 spm)			
	ON	To adjust timing of hoop movement and needle rise for thick material (The maximum sewing speed is 1000 spm)			
SW7	OFF	To set sewing start point of editing system data to first stitch			
	ON	To set sewing start point of editing system data to center of mask			
SW8	OFF	Not available (Should be set to OFF)			
	ON				

NOTE: The power of the machine should be turned off before changing switch.
If the power is not turned off, functions do not change.

Chapter 5. Entering Embroidery Date

Data available in BAS-416A · BES-1210AC

Possible data format







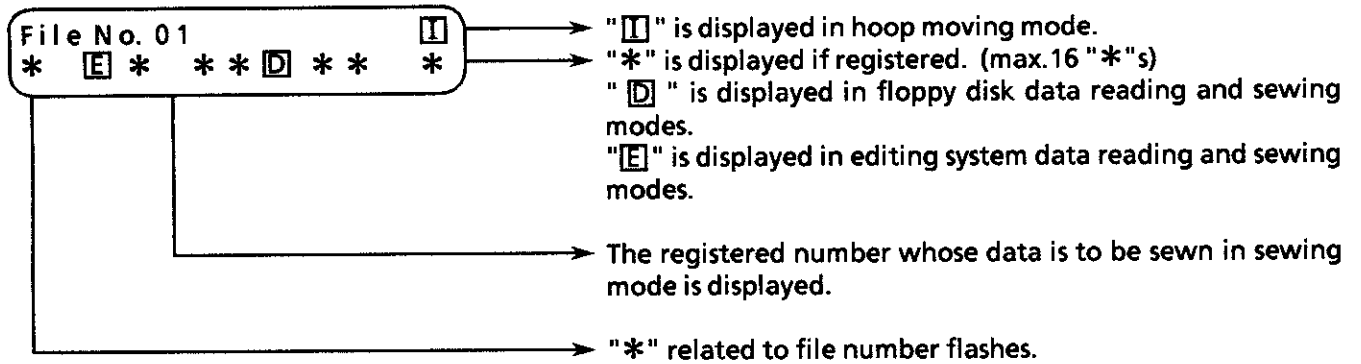





Media type	Data format	Data size per pattern (max.)
Tajima format 3.5 2DD	Tajima format Barudan format Zangs format	240,000 stitches (See note.)
3.5 2HD which corresponds to Tajima format	Tajima format Barudan format Zangs format	400,000 stitches (See note.)
Barudan format 3.5 2DD (Barudan FDR ver. III or V)	Barudan format (1 stitch data)	210,000 stitches
Paper tape with 25.4 mm width 8 holes	Tajima format Barudan format Zangs format	30,000-35,000 stitches in one reel (For more than 27000 stitches, use the memory expansion board [optional]).
Receive data from editing system	Brother stitch by stitch sewing format	999,999 stitches (See note.)

- NOTE :
- It is possible to sew patterns that exceeded stitch numbers that can use in mounted memory, but its data cannot be registered in the memory, and back-up functions for data cannot be used. Sewing, however, can be resumed after the power is cut off.
 - Data reading & embroidering mode cannot be used with Barudan FDR-format floppy disks, so load the data into memory before use.

Summary of main menu



(When the main menu is displayed, pressing the following key will select its mode.)

Available key	Function	Available key	Function
 	<ul style="list-style-type: none"> It is invalid in selecting registered data number To move hoop in hoop moving mode 		To enter needle bar selecting mode
後退 前進   BACK FORWARD	<ul style="list-style-type: none"> To select data registered number of machine side in registered number selecting mode To move hoop 		To enter thread sensor and bobbin thread counter setting mode
	To enter data entry mode from floppy disk, paper tape or editing system		To switch following alternately <ul style="list-style-type: none"> To select registered data number To enter hoop feed mode
	To enter sewing mode		To trim thread
	To enter editing mode		To feed hoop (To enter hoop feed mode.)
	To enter needle bar setting mode		

1. Entering floppy disk data

*** Input possible floppy disk**

Restricted to Tajima format 3.5" 2DD floppy disk (TFD) or 3.5"2HD floppy disk which corresponds to Tajima format or Barudan-format pattern data floppy disks (FDR 3.5 III and V format).

Ex. When entering file name (G0004) and data name (rose)

CAUTION MOVING!

File No. 01 1
 * E * * * D * * *

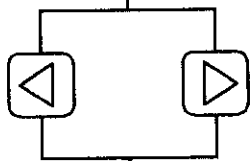

ENTER

F01: □□□□□□□□ . □□□
 □□□□□□□□ / Disk

F01: □□□□□□□□ . □□□
 Reding / Disk

F01: G 0 1 1 □ □ □ □ . DST
 File Sel / Disk

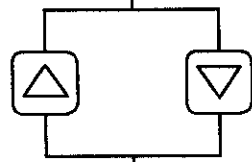

F01: G 0 0 4 . DST
 File Sel / Disk

1. Turn on the power.

2. Using the <◀> key or <▶> key, select the registered number of the machine side.

3. Press the <ENTER> key. The machine will enter the data entry mode.
 * Up to 16 patterns can be registered.

4. Insert the floppy disk.

5. Using the <▲> key or <▼> key, select the file name, G0004.

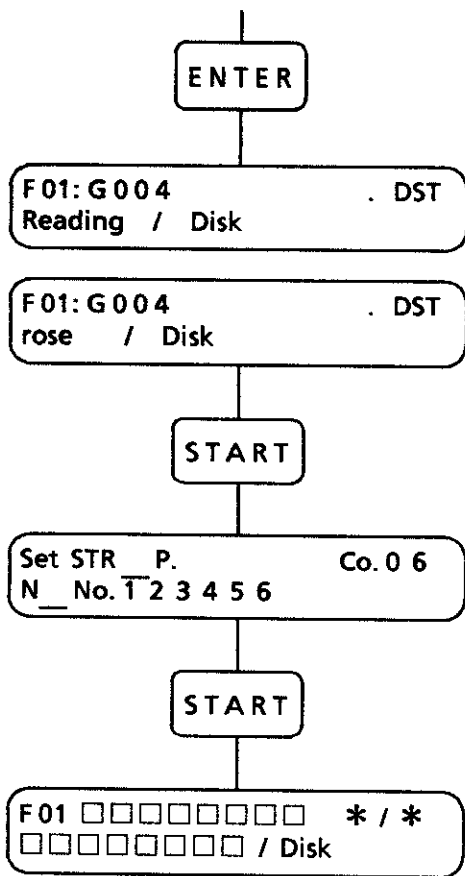

6. Press the <ENTER> key.

The display message on the lower row will change "Reading" to "rose".

7. Press the <START> key.
The machine will enter sewing mode.

8. Press the <START> key.
The machine will start sewing.

NOTE: • Repeat sewing cannot be set during floppy disk data reading or sewing (when '□' is displayed).
• Data reading & embroidering mode cannot be used with Barudan FDR-format floppy disks, so load the data into memory before use.

■ Error messages

If the following error message is displayed, press the <CLEAR> key to clear the message and cancel the error.

■ When pattern of input file name is not registered on the floppy disk



■ When the floppy disk is not set or it is defective



NOTE: Refer to page 97 "Error messages" for details.

■ Area over

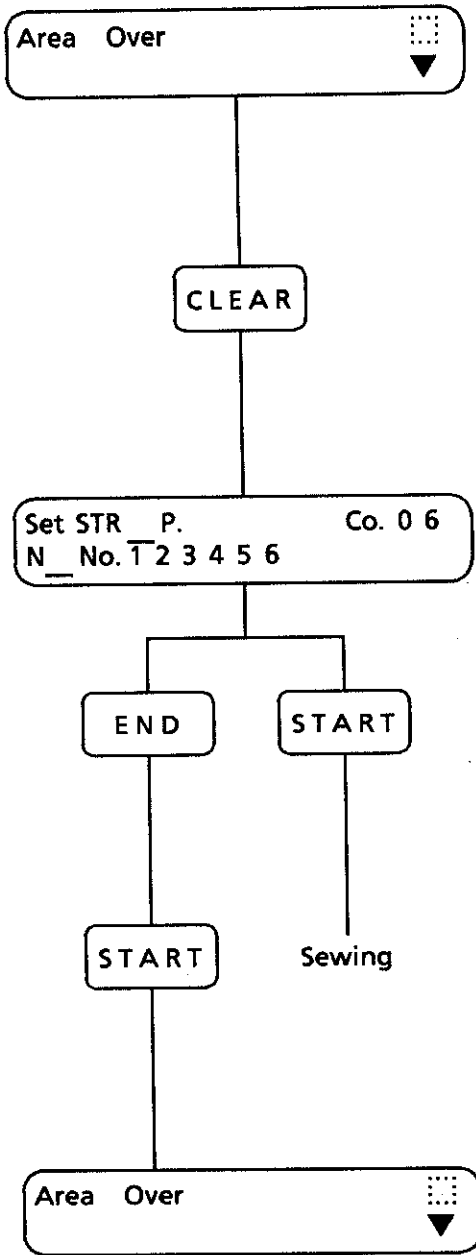

* If the needle position (hoop position) is out of the embroidering area, embroidering can still start.

1. Press the <CLEAR> key.
 - * If the <CLEAR> key is pressed when "AREA OVER" is displayed, area over checking mode will be disabled.

2. The mode will switch to embroidery mode.

- * If the <END> key is pressed, embroidery mode will be canceled, and if the <START> key is then pressed, the mode will switch back to embroidery mode and area over checking mode will be enabled.
- * If the <START> key is pressed, embroidery will then start.

NOTE:

- If embroidery is started while area over checking mode is disabled, check that the embroidery hoop stays within the possible embroidering area.
- A warning buzzer will sound when the area over checking mode is disabled to distinguish it from when area over checking mode is enabled.

■ There is a thread breakage

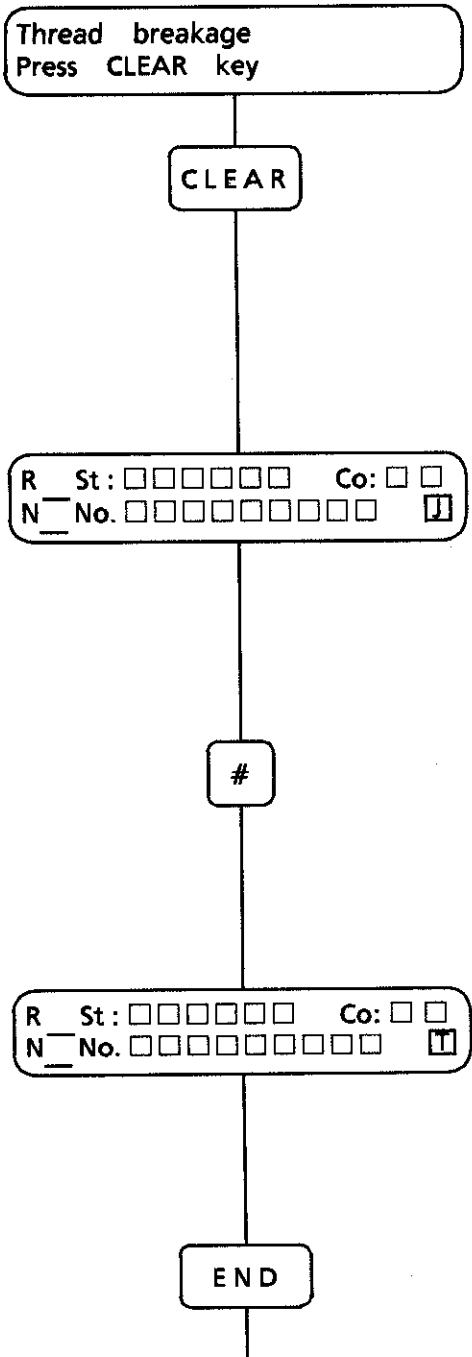

1. Press the <CLEAR> key to clear the display, and then thread the thread.

* If a thread breaks during embroidering, the following functions can be performed using the forward <◀> and <▶> keys

- ① When neither **J**, **C** or **T** is displayed, embroidery hoop can be moved a single stitch each time.
- ② When **J** is displayed, embroidery hoop can be moved to the position of the 101st stitch before the current position.
- ③ When **C** is displayed, embroidering can be performed for individual colors.
- ④ When **T** is displayed, embroidering program is returned to its start of the current embroidery data.

2. Press the <#> key to alternate between the respective modes.

















The display will change in the order **J** **C** **T** each time the <#> key is pressed.

NOTE: • If the <#> key is pressed while the **T** mark is being displayed, the **T** mark will be displayed and the mode will switch to inching mode.

If the (<◀>), (<▶>), (<△>) or (<▽>) keys are pressed after this, the embroidery frame will be moved and the embroidering position for subsequent stitches will be shifted by the amount the frame was moved, so be careful if doing this.

- It may not be possible to fully move back using the step back function while in communication or data reading & embroidering mode.
- The embroidery position sometimes may not return all the way to the embroidery start position, even when **T** is displayed.

■ The following keys are available during floppy data entry:

Available key	Function
 	To scroll file names registered in floppy disk
後退 前進  BACK FORWARD 	To select registered number of machine side
	To display pattern name of file name displayed on upper row
	To clear file data displayed on upper row and screen
	To read pattern data of file name displayed on upper row from floppy disk (This key is invalid when data is already registered in selecting number.)
	To enter sewing mode if data registered
	To enter paper tape data reading mode
	To enter editing mode
	To enter needle bar setting mode
	To enter needle bar selecting mode
	To enter thread sensor and bobbin thread counter setting mode
	To return to main menu
	To trim thread
	To feed hoop (To enter hoop feed mode)

2. Entering data from paper tape

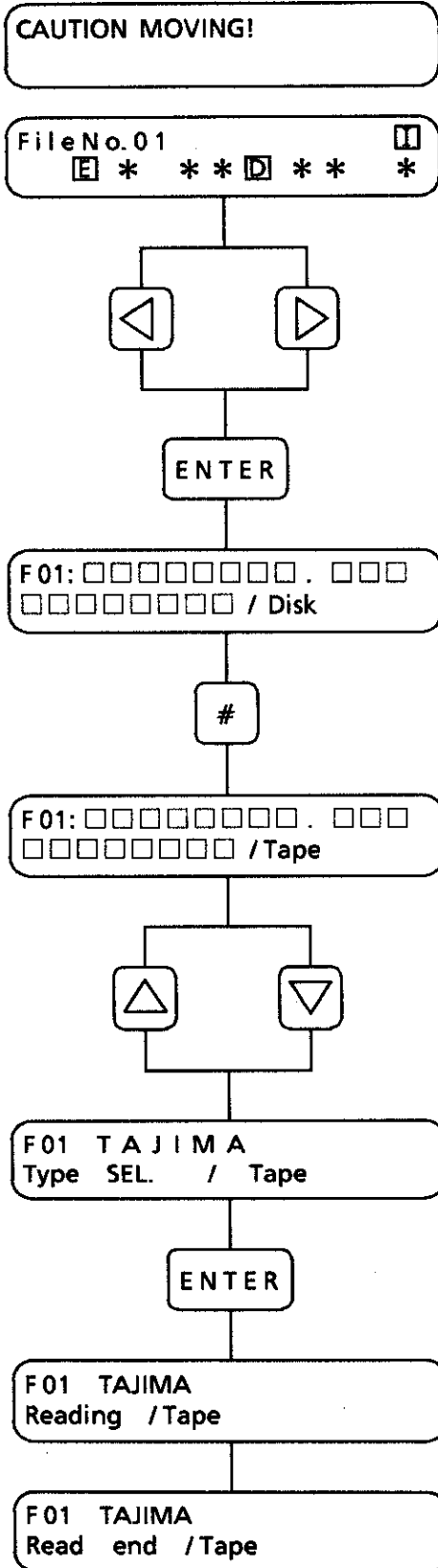

1. Turn on the power.
(Turn on the power of paper tape reader, also.)
2. Press the <<◀> key or <▶> key. Select the number of machine side.
3. Press the <ENTER> key. The machine will go into the data entry mode.
* Up to 16 patterns can be registered.
4. Press the <#> key to select the paper tape.
5. Press the <▲> key or <▼> key to select paper tape type from TAJIMA, BARUDAN and ZANGS.
6. Press the <ENTER> key.
7. After reading is completed, the buzzer sounds 'beep'.

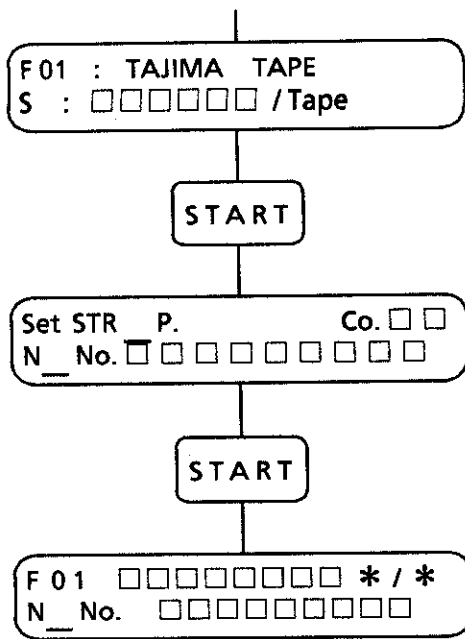

* S: shows the stitch number of paper tape data.

8. Press the <START> key.
The machine will enter sewing mode.

9. Press the <START> key.

■ ERROR MESSAGES when receiving data from paper tape reader

- If the following error message is displayed, press the <CLEAR> key to clear the message and cancel the error.
- After reading data is completed, the buzzer sounds 'beep' during fixed time.
- While the error message is displayed, the buzzer sound 'beep'. Refer to page 97 "Error messages" for details.

Tape read ERR

- (CAUSE)
- Communication cable breakage during receiving.
 - Paper tape breakage
 - Paper tape reader is turned off.
 - Improper baud rate

Off Line

- (CAUSE)
- The connection between the paper tape reader and the machine is not good.
 - Paper tape reader is turned off.
 - Communication cable breakage

CLEAR















1. Press the <CLEAR> key to clear the message above.

ENTER

2. Through the paper tape.
Press the <ENTER> key to re-start.

NOTE: While error message is displayed, the buzzer sounds 'beep' continuously.
Refer to page 97 "Error messages" for details.

■ The following keys are available during inputting floppy data:

Available key	Function
 	To select paper tape type from (TAJIMA, BARUDAN, ZANGS)
後進 前進   BACK FORWARD	To select registered number of machine side
	<ul style="list-style-type: none"> To clear file data displayed on upper row and clear screen To cancel error
	To read data from paper tape reader (This is invalid when data is already registered in selecting number.)
	To enter sewing mode if data registered
	To enter editing system data reading mode
	To enter editing mode
	To enter needle bar setting mode
	To enter needle bar selecting mode
	To enter thread sensor and bobbin thread counter setting mode
	To return to main menu
	To trim thread
	To feed hoop (To enter hoop feed mode)

F01: □□□□□□□□ . □□□
Line ERR. /Editor



(CAUSE)

- Data error during communication.
- Cable disconnection during communication.
- The BAS-PC/EM system is turned off during communication.

















CLEAR

ENTER













1. Press the <CLEAR> key to clear the error messages above.

2. Press the <ENTER> key to re-start.

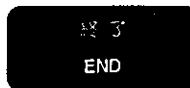
■ The following keys are available during reading data from BAS-PC/EM system;

Available key	Function
 	To scroll file names registered in editing system
後退 前進   BACK FORWARD	To select registered number of machine side
	To display pattern name of file name displayed on upper row
	<ul style="list-style-type: none"> To clear file data displayed on upper row and clear screen To cancel error
	To read pattern data of file name displayed on upper row from editing system (This is invalid when the data is already registered in selecting number.)
	To enter sewing mode if data registered
	To enter floppy disk data reading mode
	To enter editing mode
	To enter needle bar setting mode
	To enter needle bar selecting mode
	To enter thread sensor and bobbin thread counter setting mode
	To return to main menu
	To trim thread
	To feed hoop (To enter hoop feed mode)

■ The following keys are available in the editing menu:

Available key	Function
	To select editing item cyclically
後退 前進  BACK FORWARD	To select registered number of machine side
	To check set values of registered number selected with above key
	To clear set values of registered number selected with above key (To return to default value)
	To enter editing mode of editing item selected
	To enter entry mode
	To enter sewing mode
	To return to main menu
	To enter needle bar setting mode
	To enter needle bar selecting mode
	To enter thread sensor and bobbin thread counter setting mode
	To trim thread
	To feed hoop (To enter hoop feed mode)

2-3. Setting repeat sewing

A monogram can be set horizontally or vertically up to 9 times. Also, space between patterns can be set in the range from 0 mm to 399 mm by 1 mm increment. These setting can be changed every registered pattern.

F 01: □□□□□□□□ . □□□
(1) Rotation ↓



F 01: □□□□□□□□ . □□□
(2) Mirror ↓



F 01: □□□□□□□□ . □□□
(3) Repeat ↓

EDIT

Repeat : V 1 Time
Space : 006 mm

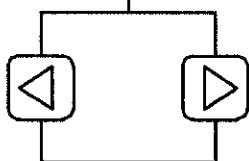

Repeat : V 1 Time
Space : 006 mm

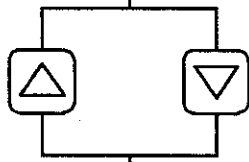

Repeat : V 1 Time
Space : 106 mm

#

END

1. Select "(3) Repeat" in the editing menu with <▽> key.

2. After selecting, press the <EDIT> key.

3. Information of repeat sewing setting is displayed. Change the cursor position on the number with <◀> key and <▶> key.

4. Enter the repeat times and space length with the <△> key and <▽> key.
* The numbers 1 to 9 are scrolled.





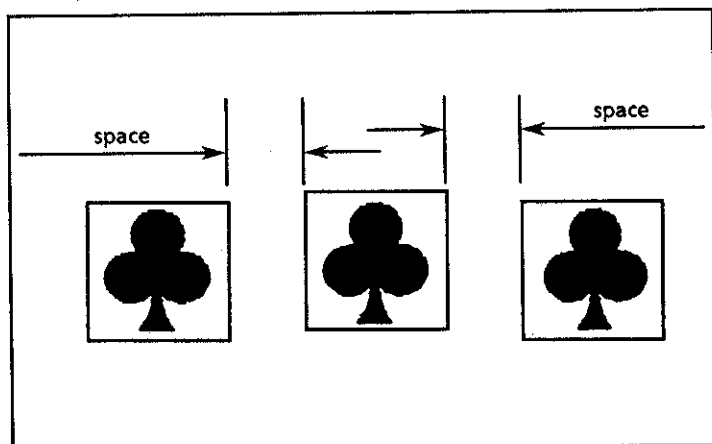

5. Press the <#> key to select the repeat direction, either vertical direction or horizontal direction.
* "V" and "H" are displayed alternately.

6. After setting, press the <END> key.

example: setting repeat sewing and spacing



■ The following keys are available in the setting repeat sewing:

Available key	Function
後退 前進   BACK FORWARD	To change cursor position on number
 	To enter repeat times or space length (The numbers 1 to 9 are selected cyclically.)
	To decide repeated direction (vertical or horizontal) (Repeat direction is selected cyclically.)
	To return to default values (once horizontally, spacing 0 mm)
	To return to editing menu

NOTE: For the floppy disk data or the editing system data, setting repeat sewing cannot be done in the reading or sewing mode (when 'D' or 'E' is displayed).

Chapter 7. Sewing Function

1. Explanation of sewing function

Set STR P. Co.
N No.

Selects the embroidering mode.

F01: * / *
N No.

Sewing
During sewing or during test feeding

R St: Co:
N No.

Suspension
An emergency stop results suspension.

C No: Co.
N No.

Needle bar setting mode
Needle bar order (color order) may be set.

Needle No. 1

Needle bar selecting mode
To select needle bars.

Return > Hoop Feed
Hoop Feeding

Hoop feed mode
To set hoop feed point.

Move to Hoop > ENT
X : mm Y : mm

(after the jog key is used)

B. T. Count : /
ST. Count :

Thread sensor ON/OFF, B.T. counter setting mode

2. Setting hoop feed point

- To make the removal and attachment of the embroidery hoop easier, besides current needle position, a new position can be set as a hoop feed point in range of movable area.
- To make an operation such as material attachment smooth while the machine suspends, pressing the <HOOP FEED> key can move the hoop to the hoop feed point anytime.
- It is possible to set or not automatic hoop feed after sewing. (This cannot be set every registered pattern.)

A feed hoop point can be set every registered pattern.

Set STR P. Co. □ □
N_ No. □ □ □ □ □ □ □ □ □ □

(sewing mode)

R_ St: □ □ □ □ □ □ Co: □ □
N_ No. □ □ □ □ □ □ □ □ □ □

(during suspension)

HOOP
FEED

1. Press the <HOOP FEED>key in sewing mode or during suspension.

Return > Hoop Feed
Hoop Feeding



2. Set the hoop feed point by pressing the jog key.
※ The coordinates of X and Y axes will be displayed.

Move to Hoop > ENT [S]
X : 095 mm Y : 067 mm

3. Decide hoop feed point by pressing the <ENTER> key.

ENTER

Move to Hoop > ENT [S]
X : 110 mm Y : 083 mm

4. Set whether hoop feed is performed or not after sewing by pressing the <*> key.
·After setting, an [S] mark will appear in the upper-right corner.

*

Move to Hoop > ENT [S]
X : 110 mm Y : 083 mm



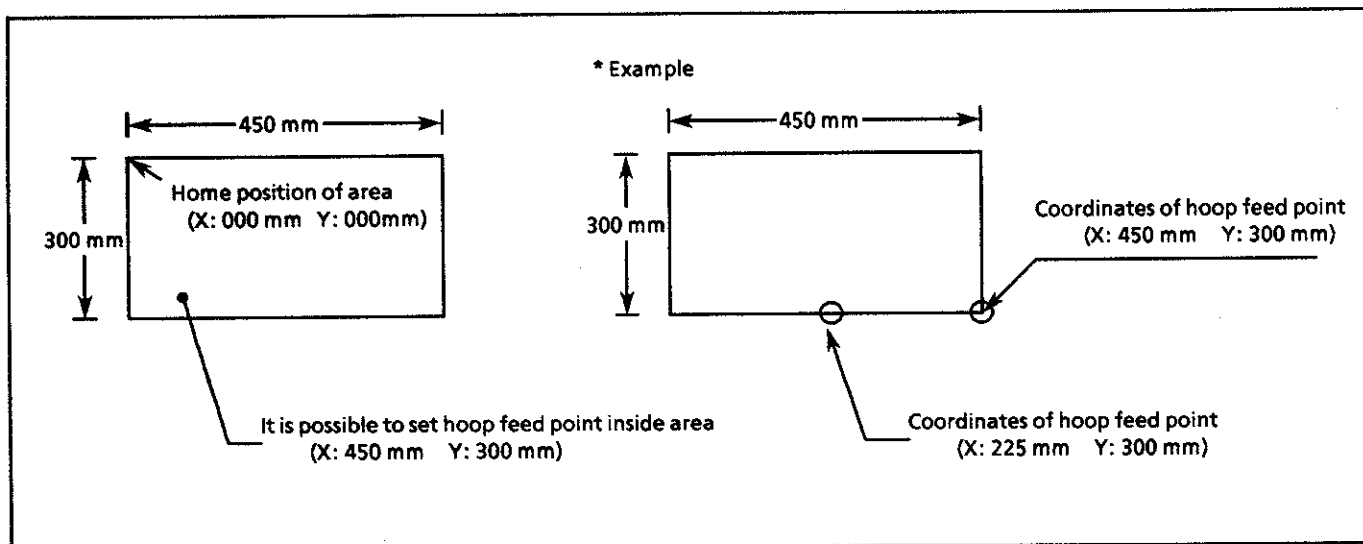

5. After setting coordinate value, press the <HOOP FEED> key. The machine will return to sewing mode.

HOOP
FEED

Set STR P. Co. □ □
N_ No. □ □ □ □ □ □ □ □ □ □



■ The following keys are available in the hoop feed point:

Available key	Function
	To move needle position to desired hoop feed point
	To decide automatic hoop feed after sewing or not (" [S] " (set) mark is displayed alternately.)
	To enter current needle position as hoop feed point and display its coordinates
	To set hoop feed point in center of area
	To return from hoop feed point and exit from this mode

3. Needle bar setting

The needle selected can be set to any number from 1 to 9 (for the BAS-416A) or to any number of letter from 1 to 9 and A to C (for the BES-1210C). A maximum of 99 needle changes can be set when changing colors. Also, automatic sewing stops can be turned on or off for each color change.

Set STR P. Co.
 N No.

(sewing mode)

R St: Co:
 N No.

(during suspension)

NEEDLE SET

C No: Co:
 N No.

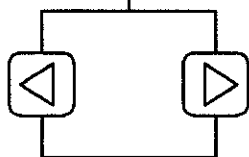

1. Press the <NEEDLE SET> key in sewing mode or during suspension.
 * The **S** mark is displayed when an automatic embroidery suspension has been set to occur during a color change.

C No: **S** Co:
 N No.

2. Set color order number with the <◀> key and <▶> key.



C No: **S** Co:
 N No.

3. Use the <▽> and <△> keys to select the needle number.
 - To select needle number
 (The BAS-416A shows a scrolling display of numbers from 1 to 9.)
 (The BES-1210AC shows a scrolling display of numbers and letters from 1 to 9 and A to C.)
 Alphabetical display
 The corresponding needle numbers are A = 10, B = 11 and C = 12.
 - However, if the needle number selected is the same as the preceding needle number, an automatic suspension will be set and the **S** mark will be displayed. In addition, if the needle number selected is the same as the subsequent needle number, an automatic suspension will be set for the subsequent needle number.
 An automatic suspension can also be set manually by pressing the <ENTER> key.

END







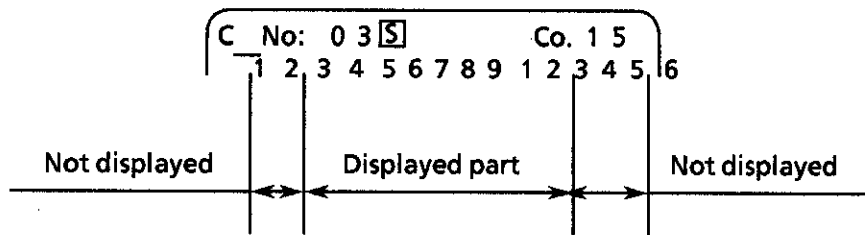

4. After the needle bar settings have been completed, press the <END> key to exit this mode and return to embroidery mode.

Set STR P. Co.
 N No.

Example) When the third color number of the fifteen colors in all is set



■ Keys available when carrying out needle bar settings

Available key	Function
 	To set color order number
 	To select needle number (The BAS-416A shows a scrolling display of numbers from 1 to 9.) (The BES-1210AC shows a scrolling display of numbers and letters from 1 to 9 and A to C.) Alphabetical display The corresponding needle numbers are A = 10, B = 11 and C = 12.
	To decide automatic stop or not (" [S] " (set) mark is displayed alternately.)
	To use needle number set in data regardless of machine side data as long as receive data from editing system is input (This is invalid for floppy disk data and paper tape data.)
	To set selecting needle number to default value To set the selected needle bar number to the standard value (1 to 9 for the BAS-416A, 1 to 9 and A to C for the BES-1210AC).
	To exit from needle bar setting mode

* The needle bar setting can be changed manually to the desired number from 1 to 9 (for the BAS-416A) or from 1 to 9 and A to C (for the BES-1210AC).

4. Selecting needle bar

A needle bar can be moved in the needle hole of needle plate.

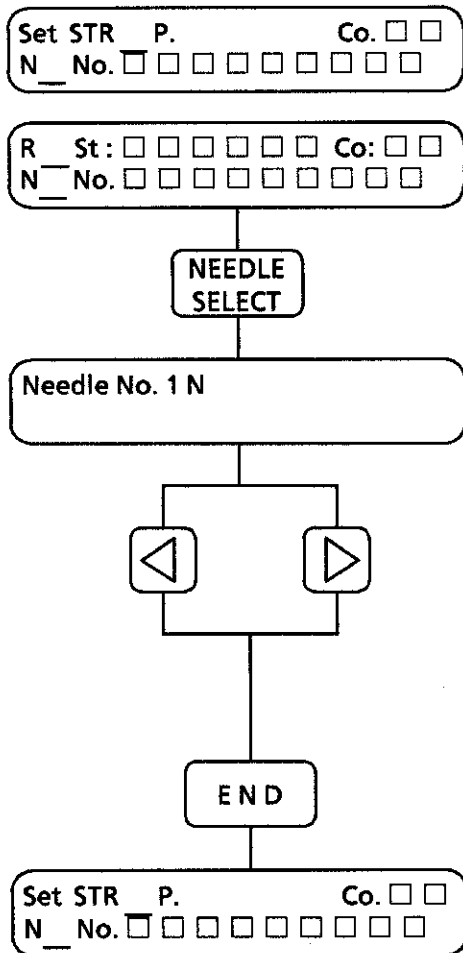

(sewing mode)

(during suspension)

1. Press the <NEEDLE SELECT> key in sewing mode or during suspension.
 - ※ "N" Indicates that the needle bar selection position is normal.
 - "O" Indicates that there is a problem with the needle bar selection position.
2. Select the needle number with the <◀> key and <▶> key.
 - In for the BAS-416A, the setting will scroll through the numbers 1 to 9; for the BES-1210AC, the setting will scroll through the numbers 1 to 9 and the letters A to C.
 - The needle bar case will move to the needle bar number selected.
3. After selecting needle number, press the <END> key. The machine will return to sewing mode.

■ Error messages

If the following errors occur, follow the error messages to cope with the situation.





1. If the needle bar case is not in proper position

N_ Case POS. Error
Set NC in order

2. If the needle bar case is locked and would not move

N_ Case Lock
Press CLEAR key

■ The following keys are available in the selecting needle bar:

Available key	Function
前進  FORWARD	To select needle bar in direction of number 1
後退  BACK	To select needle bar in direction of number 9 to 12
 クリア CLEAR	To cancel needle bar case lock error
 終了 END	To exit from needle bar selecting mode

NOTE: Refer to page 97 "Error messages" for details.

5. Setting bobbin thread counter and thread breakage sensor

- The display is based on counter system which the number is decreased after sewing one pattern is completed or is canceled. After counting is completed, it can show the messages with beep sound when starting next sewing. The counter number can be set from 0 to 99. Also, ON/OFF of thread breakage detection can be switched.
- The bobbin thread counter can be set before data entry, during data input, and after data input.

Set STR P. Co. □ □
N_ No. □ □ □ □ □ □ □ □

(sewing mode)

R St : □ □ □ □ □ □ Co: □ □
N_ No. □ □ □ □ □ □ □ □

(during suspension)

THREAD
SENSOR

B. T. Count : □ □ / □ □
ST. Count : □ □ □ □ □ □

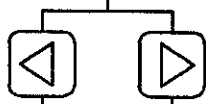

*

B. T. Count : □ □ / □ □ 5
ST. Count : □ □ □ □ □ □

END

Set STR P. Co. □ □
N_ No. □ □ □ □ □ □ □ □

- Press the <THREAD SENSOR> key in sewing mode or during suspension.
* When the <THREAD SENSOR> key is pressed and the upper left indicator lights, thread breakage detection will operate.
- Move the cursor on the desired row with the <◀> key and <▶> key. (The cursor will move.)
- Enter the set times with the <▲> key and <▼> key.
* The numbers 1 to 9 are selected cyclically.
- Press the <*> key to select ON/OFF of the bobbin thread counter.
- After entering set times, press the <END> key. The machine will enter sewing mode.

* ST. Count :
Total stitch number is displayed here until it is cleared.
It can be stored even though the power is turned off.

Available key	Function
▲ ▼	To select needle number (The BAS-416A shows a scrolling display of numbers from 1 to 9.) (The BES-1210AC shows a scrolling display of numbers and letters from 1 to 9 and A to C.) Alphabetical display The corresponding needle numbers are A = 10, B = 11 and C = 12.
● 糸切れセンサ THREAD SENSOR	To switch thread breakage sensor (ON and OFF are alternately displayed.)
クリア CLEAR	To change current counter number to set value
終了 END	To exit from this setting

Available key	Function
*	To switch ON/OFF of bobbin thread counter function
#	To clear stitch number counter
後進 前進 BACK FORWARD	To change cursor position on number (The cursor will appear and move.)

* The amount of thread to be left after thread trimming can be set to one of three settings.

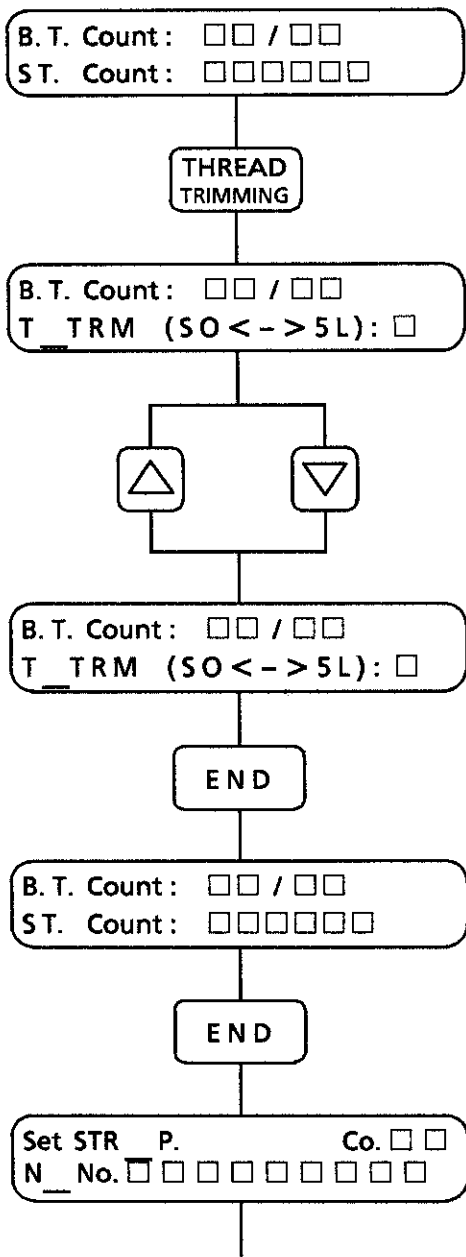

1. After setting the bobbin thread counter and stitch counter, press the <THREAD TRIMMING> key.
2. The mode will switch to remaining thread setting mode.
3. Use the <△> and <▽> keys to set the amount of thread to be left after thread trimming.
 - * 0: Short
 - 3: Normal
 - 5: Long
4. After setting, press the <END> key.
5. Press the <END> key to return to embroidery mode.

Available key	Function
*	To set the amount of thread to be left after thread trimming to setting 0, 3 or 5

6. Function of speed volume table setting

- At the time of sewing start or at the time of stoppage while in the process of sewing, it is possible to have six selections for the setting of the four steps of maximum sewing speed by the speed volume on the operational panel.
- The selection is based on the situation of the following three switches, plus one of the selections from the panel, vide the following charts.
 Operation panel Dip SW = 6 (Thin, thick material)
 Operation panel Dip SW = 8 (Hoop type)
 Cap frame SW (Flat, cap frame)

The way of operation

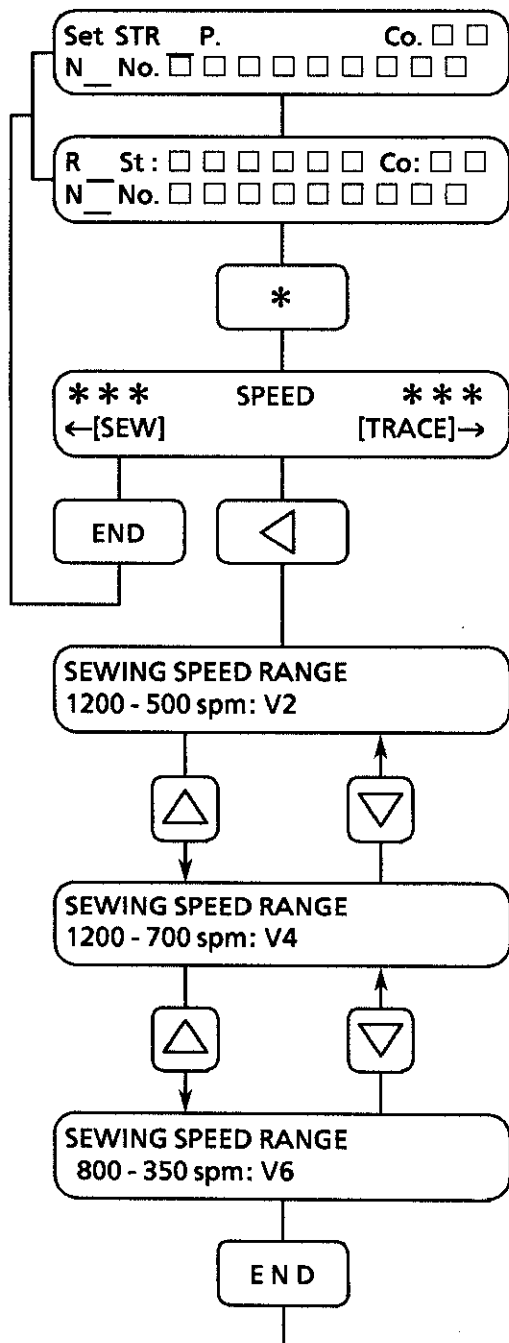

At time of sewing start

At time of stoppage in the sewing process

1. When <*> key is pressed, the machine will enter into the mode for speed change.

2. When <<> key is pressed, the machine will enter into the mode for speed volume change.
* When <END> key is pressed, return to sewing mode.

The presently set volume No. will appear.

3. When pressing <△> and <▽> keys, volume table No. will change.
NOTE: Selectable volume No. changes according to the situation of panel Dip SW 6, 8 and cap frame SW. (Refer to item 1-1)

4. When <END> key is pressed, the machine will return to the mode of speed menu selection.

■ The relation between SW and volume table

Panel Dip SW = 6 table	Panel Dip SW = 8	Cap frame SW	Panel selection
OFF (thin material mode)	OFF (maximum area)	Flat frame mode	V2 (When the power is turned on to clear and reset the memory) V4 V6
ON (thick material mode)	OFF (maximum area)	Flat frame mode	V1 (When the power is turned on to clear and reset the memory) V3 V5
OFF (thin mode)	ON (maximum area)	Flat frame mode	V2 (When the power is turned on to clear and reset the memory) V4 V6
ON (thick mode)	ON (maximum area)	Flat frame mode	V1 (When the power is turned on to clear and reset the memory) V3 V5
OFF (thin mode)	OFF (standard cap area)	Cap frame mode	V1 (When the power is turned on to clear and reset the memory) V3 V5
ON (thick mode)	OFF (standard cap area)	Cap frame mode	V1 (When the power is turned on to clear and reset the memory) V3 V5
OFF (thin mode)	ON (wide cap area)	Cap frame mode	V1 (When the power is turned on to clear and reset the memory) V3 V5
ON (thick mode)	ON (wide cap area)	Cap frame mode	V1 (When the power is turned on to clear and reset the memory) V3 V5

NOTE:

- When cap frame SW is not installed, it will be automatically flat frame mode.
- For the BAS-416A · BES-1210AC, refer to page 9 of the BAS-416A · BES-1210AC Instruction Manual as how to clear and reset the memory.

■ The relation between volume table No. and display

Volume table No.	Table selection display	Speed volume and max speed			
		Range 1	Range 2	Range 3	Range 4
V1	1000 - 500 spm: V1	1000 spm	800 spm	700 spm	500 spm
V2	1200 - 500 spm: V2	1200 spm	1000 spm	800 spm	500 spm
V3	1000 - 700 spm: V3	1000 spm	900 spm	800 spm	700 spm
V4	1200 - 750 spm: V4	1200 spm	1000 spm	850 spm	750 spm
V5	650 - 350 spm: V5	650 spm	550 spm	450 spm	350 spm
V6	650 - 350 spm: V6	650 spm	550 spm	450 spm	350 spm

7. Function of speed setting for test feed

It is possible to change the speed for tracing of the outer shape of a pattern prior to sewing, at the time of sewing start and also at the time of stoppage of sewing while in the sewing process. Once this speed has been changed, feed speed during sewing and also thread pulling speed at time of thread trimming will change in line with this change.

The way of operation

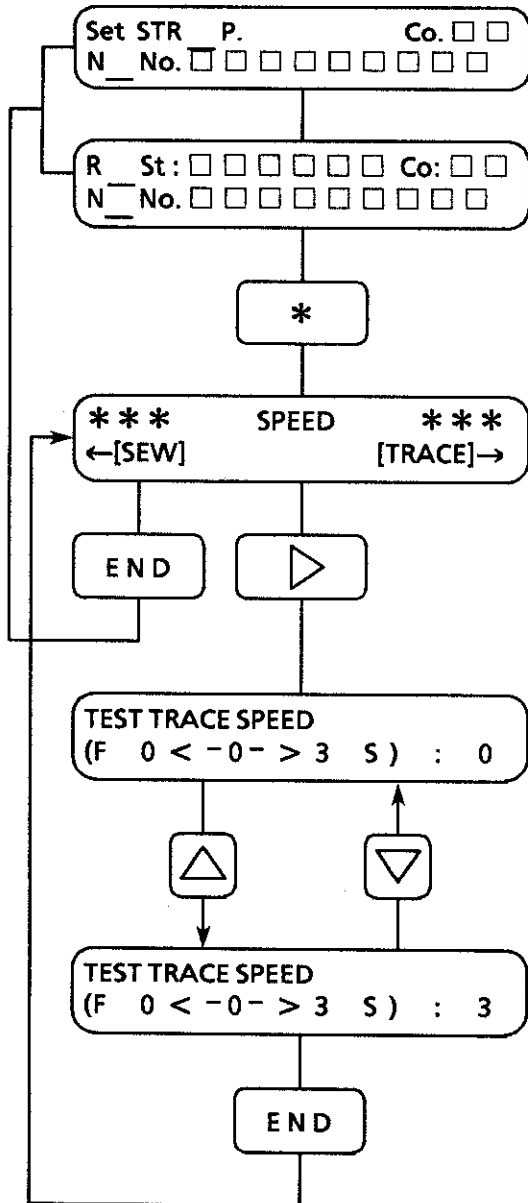

At time of sewing start

At time of stoppage while in the process of sewing

1. When <*> key is pressed, the machine will enter into the speed change mode.

* When <END> key is pressed, the machine will return to the display of sewing mode.

2. When <▶> key is pressed, there appears the test feed speed change mode.

The presently set range will appear on the display.

3. When <▲> and <▼> keys are pressed, range No. will change.

NOTE: The possible selectable range No. is 0 - 3.
(3 is the slowest speed)

4. When <END> key is pressed, the machine will return to the display of speed menu selection.

NOTE: The speed setting value for the test feed will be changed automatically in accordance with changes in the sewing area for the model of sewing machine being used.

8. Function of sewing area selection

■ Function of sewing area according to the type of frame (flat frame mode)

It is possible to have a selection from the operation panel menu of the 3 different types of frames where the needle transferring area from the sewing start and the area for area check have been already set.

The way of operation Cap frame SW = OFF (flat frame mode)

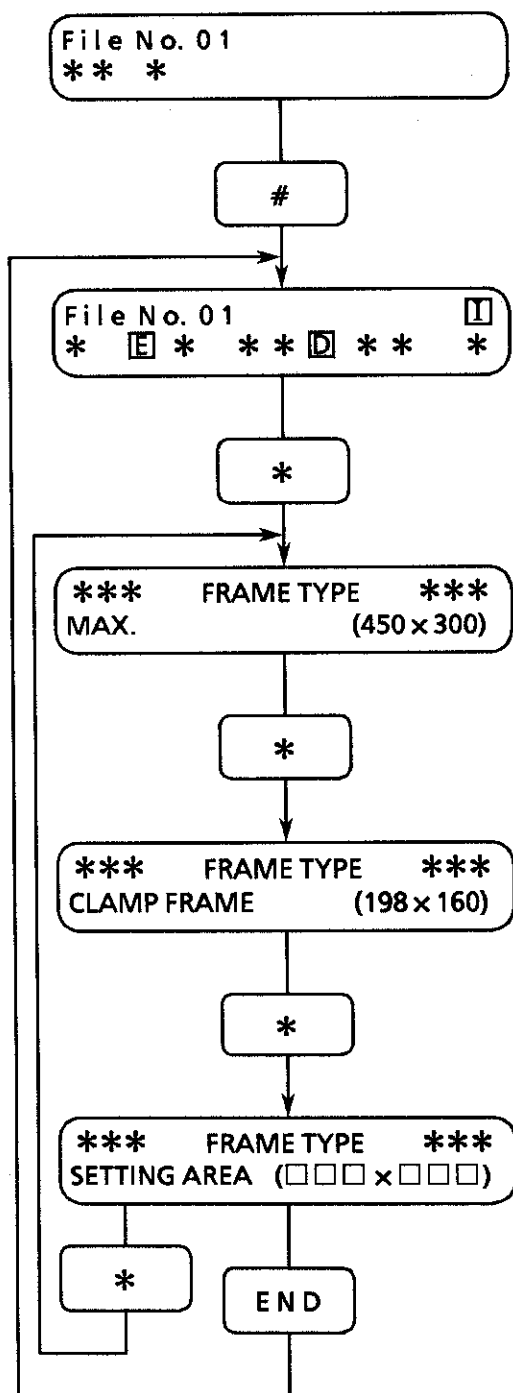

Main menu display

1. Press <#> key and enter into inching mode.

2. When <*> key is pressed, there appears on the display the change mode of frame type.

* There appears the frame type already set presently.

3. When <*> key is pressed, the frame type will change.
NOTE: Selection of the display is possible only with those frames for which the present needle location is within the frame area.
When selecting the frame type that cannot be selected, return to inching mode and move the needle position to where it is within the area of the frame you want to select.

* As to the setting area, the formerly set area size (□□□ x □□□) will appear on the display.

4. When <END> key is pressed, the machine will return to inching mode.

■ Function of optional setting of sewing area by specifying two points (flat frame mode)

It is possible to change the area of needle transfer at time of sewing start and also the area for area check, by setting the sewing area with the optional two points' forming a diagonal of that sewing area.

The way of operation

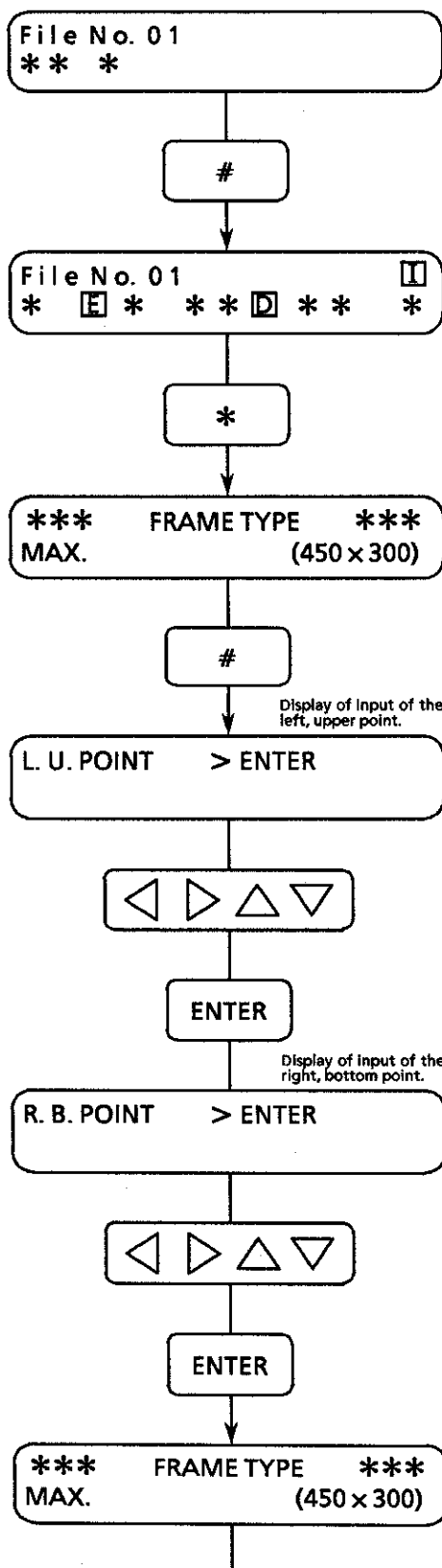

Main menu display

1. After pressing <#> key, enter into inching mode.

2. When <*> key is pressed, there appears on the display the mode for changing the frame type.

* The presently set frame type will appear on the display. If the maximum frame area is not on the display, press <*> key to select the maximum possible frame.

3. When <#> key is pressed, the display of area setting will appear.

4. Press <◀▶▲▼> keys, and specify the left, upper point.

5. Press <ENTER> key.

6. Press <◀ ▶ ▲ ▼ > keys, and specify the right, bottom point.

NOTE: Set the right, bottom point to be at the right, bottom side of the point where there is left, upper point already set.

7. Press <ENTER> key.

* The maximum possible frame area will appear on the display.

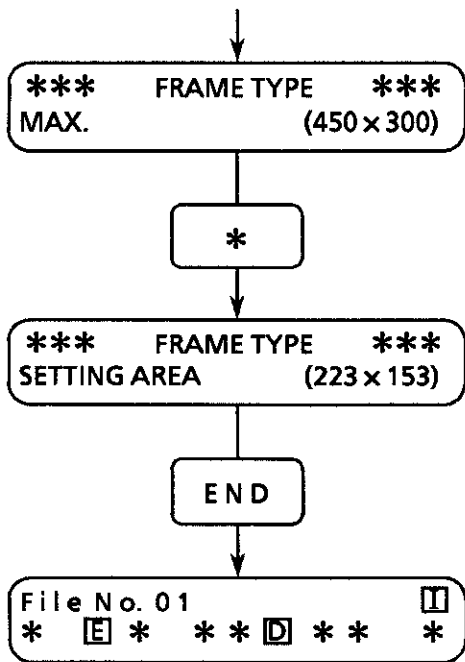

8. Press <*> key once or twice to select the setting area.

* The display shown at the left hand side is an example when the size of the set area is appear the following drawing.

9. Press <END> key.

The machine will return to inching mode.

* After all the above operations have been done, the area optionally set will become the area of needle transfer and the ara of area check.

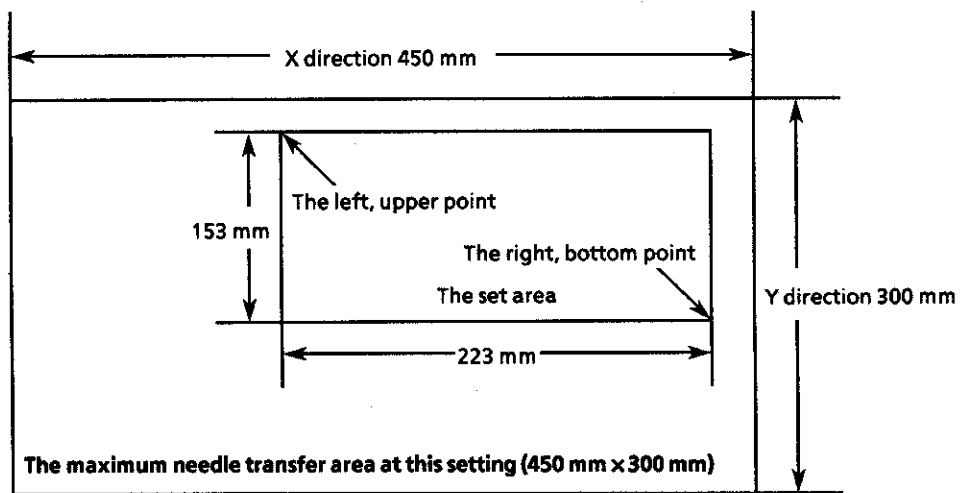

The operator side

■ Function of selection of sewing area by the type of frame (cap frame mode)

It is possible to make selection on the operation panel out of the 3 different types of frame, where the area of needle transfer at time of sewing start and the area of area check have been already set. One type of frame will be selected on the panel menu out of the 3 different types according to the situation of SW in the following item 2.

- * Operation panel Dip SW 8 (the type of frame)
 - SW 8 = ON wide cap frame mode
 - SW 8 = OFF standard cap frame mode
(not possible to select the cap frame type)

* Cap frame SW = ON (cap frame mode)

The way of operation

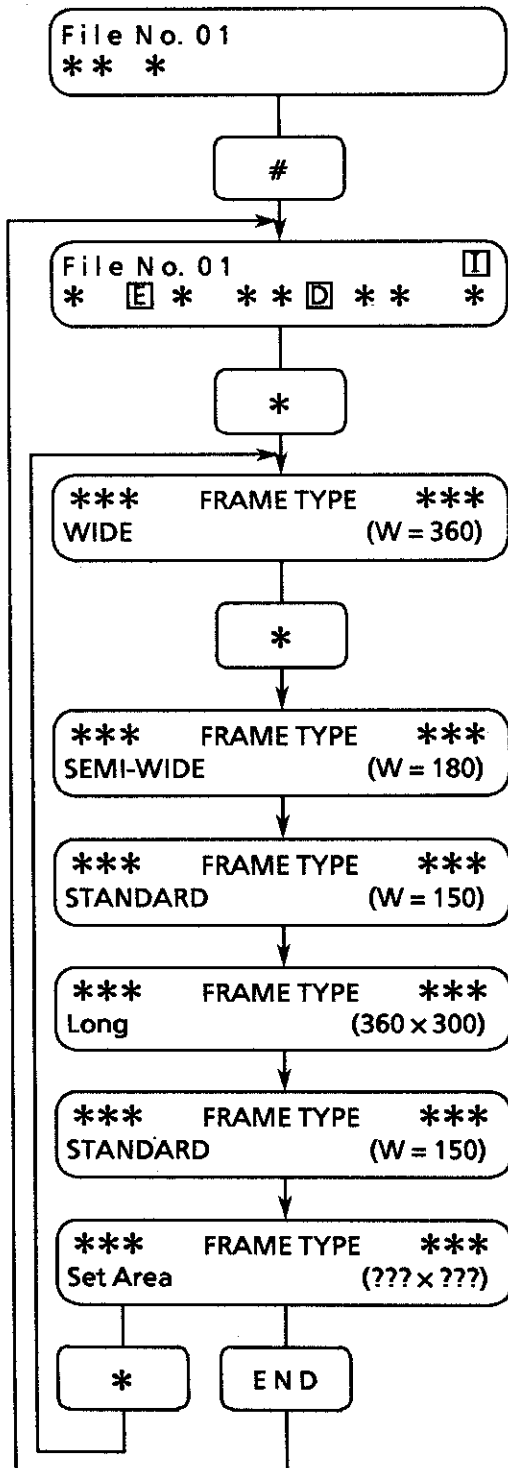

Main menu display

1. After pressing <#> key, enter into inching mode.

2. When <*> key is pressed, there appears on the display to change the frame type.

* The presently set cap frame type will appear on the display.

3. When <*> key is pressed, the cap frame type will change.

NOTE: The selection is possible only in the case of cap frame type where the present needle location is within the area of that frame. If the cap frame type is selected that is not possible to select, the machine will return to inching mode. At that time, move the needle location to be within the area of the frame type to be selected.

4. When <END> key is pressed, the machine will return to inching mode.

■ The relation between SW at time of power on and sewing area

Panel Dip SW = 8	Cap frame SW	Selection of frame type on operation panel
OFF (maximum area)	Flat frame mode	<u>Maximum (450 × 300)</u> (When the power is turned on to clear and reset the memory) Clamp hoop (198 × 160) Setting area (??? × ???)
ON (maximum area)	Flat frame mode	<u>Maximum (450 × 300)</u> (When the power is turned on to clear and reset the memory) Clamp hoop (198 × 160) Setting area (??? × ???)
OFF (Air clamp L)	Air clamp mode	<u>Air hoop L (120 × 180)</u> (When the power is turned on while pressing the clamp switch) Air hoop M (90 × 60) Air hoop S (60 × 40) Maximum (450 × 300) Setting area (??? × ???)
ON (Air clamp L)	Air clamp mode	<u>Air hoop L (120 × 180)</u> (When the power is turned on while pressing the clamp switch) Air hoop M (90 × 60) Air hoop S (60 × 40) Maximum (450 × 300) Setting area (??? × ???)
OFF (standard cap area)	Cap frame mode	Not possible to select frame type <u>Standard (W = 150)</u> (When the power is turned on to clear and reset the memory)
ON (wide cap area)	Cap frame mode	<u>Wide (W = 360)</u> (When the power is turned on to clear and reset the memory) Semi wide (W = 180) Standard (W = 150) Long (360 × 300) Baseball (160 × 75) Setting area (??? × ???)

NOTE:

- When cap frame SW is not installed, the machine will automatically enter into flat frame mode.
- When the power is turned on with the clamp switch being pressed in the flat frame mode, the machine will go into the air clamp mode.
- For the BAS-416A · BES-1210AC, refer to page 9 of the BAS-416A · BES-1210AC Instruction Manual as how to clear and reset the memory.

9. Function of setting feed volume of thread pulling at time of thread trimming

It is possible on the operation panel to change the setting of the feed volume for pulling out lower thread and upper thread from the material at time of thread trimming while sewing, by increment of 10 mm between the area of 0 - 80 mm.

(The set figures are kept in the machine by back up even if the power has been cut off.)

The way of operation

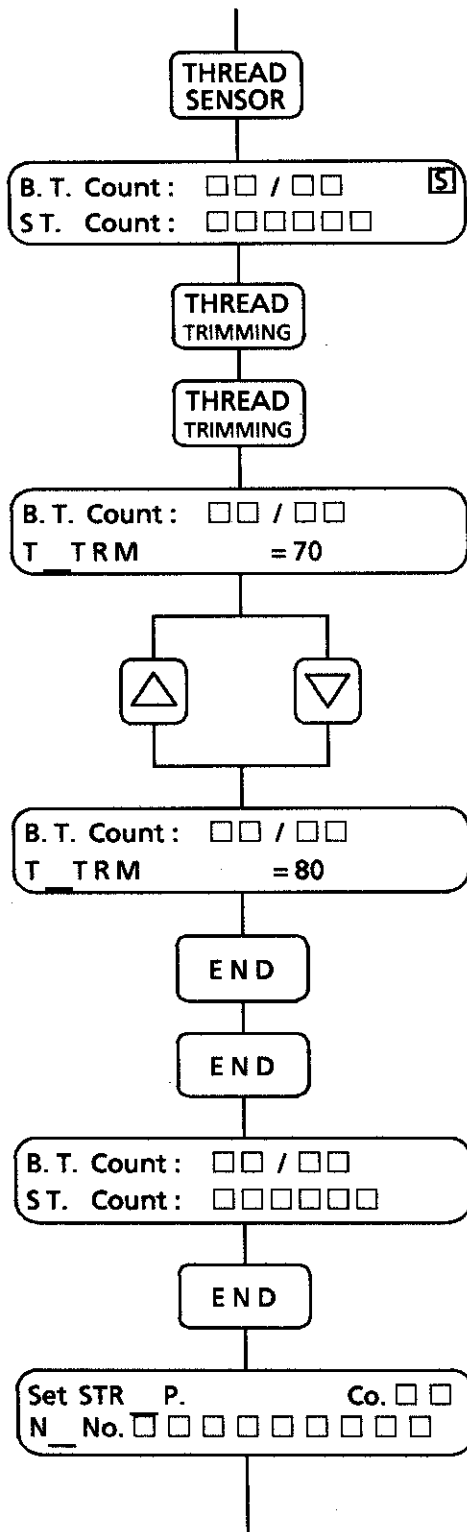

1. Press <THREAD SENSOR> key.

Bobbin thread counter, thread sensor setting mode display

2. After setting the bobbin thread counter and stitch counter, press the <THREAD TRIMMING> key twice.

3. The display to set and change the feed length for pulling out of threads.

4. When <△> <▽> keys are pressed, the length will be changed by the unit of 10 mm.

* 0: Short

↓

80: Long

NOTE: When the PROM version is A or B for the BAS-401, or either of A, B, or C for the BAS-416A, the feed amount for thread pulling ranges from 20 to 80 mm.

5. After setting is completed, press the <END> key twice.

6. Press the <END> key to return to embroidery mode.

■ Keys available when carrying out setting feed volume:

Available key	Function
△ ▽	To change the amount to move the frame so that the needle thread can be pulled out after thread trimming.

10. Skip function of 0 mm stitch

It is possible to select on the operation panel whether to sew 0 mm stitch or not, which exists in the sewing data. (At the time of power having been input, the machine is always set to "sew".)

The way to operation

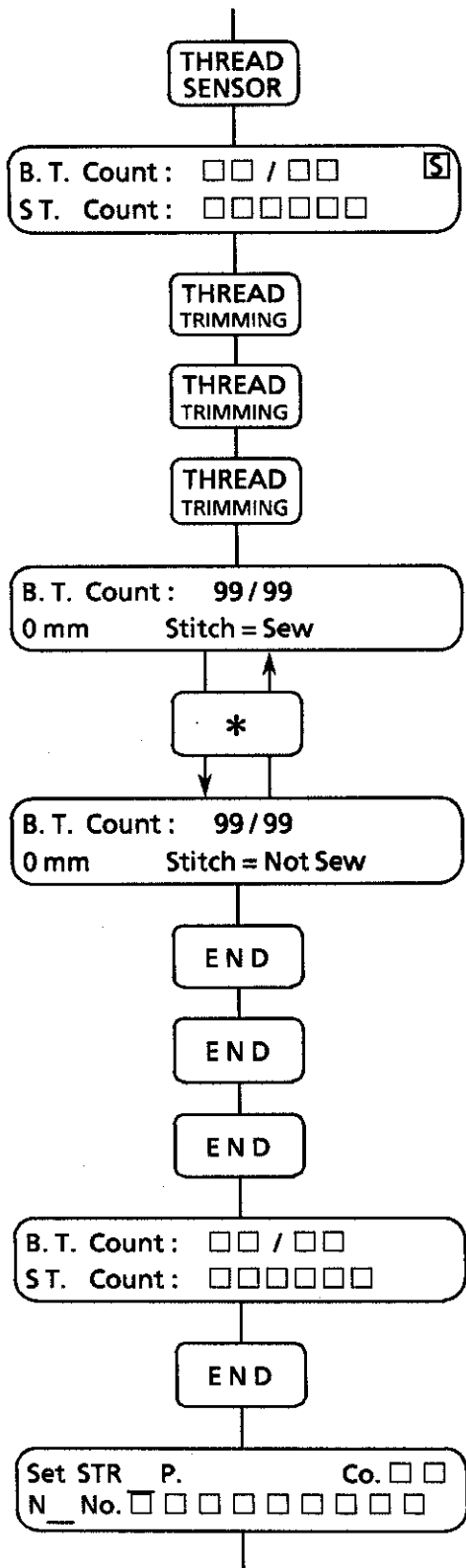

1. Press <THREAD SENSOR> key.

Bobbin thread counter, thread breakage sensor setting mode display

2. After setting the bobbin thread counter and stitch counter, press the <THREAD TRIMMING> key three times.

The mode will switch to frame movement setting mode.

3. Press the <*> key to turn sewing on or off.
* The setting switches between ON and OFF each time the <*> key is pressed.

4. After setting is completed, press the <END> key three times.

Bobbin thread counter, thread breakage sensor setting mode display

5. Press the <END> key to return to embroidery mode.

■ Keys available when carrying out skip function of 0 mm stitch:

Available key	Function
*	To change the 0-mm stitch sewing setting to ON or OFF.

11. Function to select alarm at time of thread breakage

It is possible on the operation panel to select out of the following 4 different types of alarm, in the case of the machine having been stopped due to thread breakage during sewing.
(The value set will remain stored in the backup even when the power is turned off.)

The way to operation

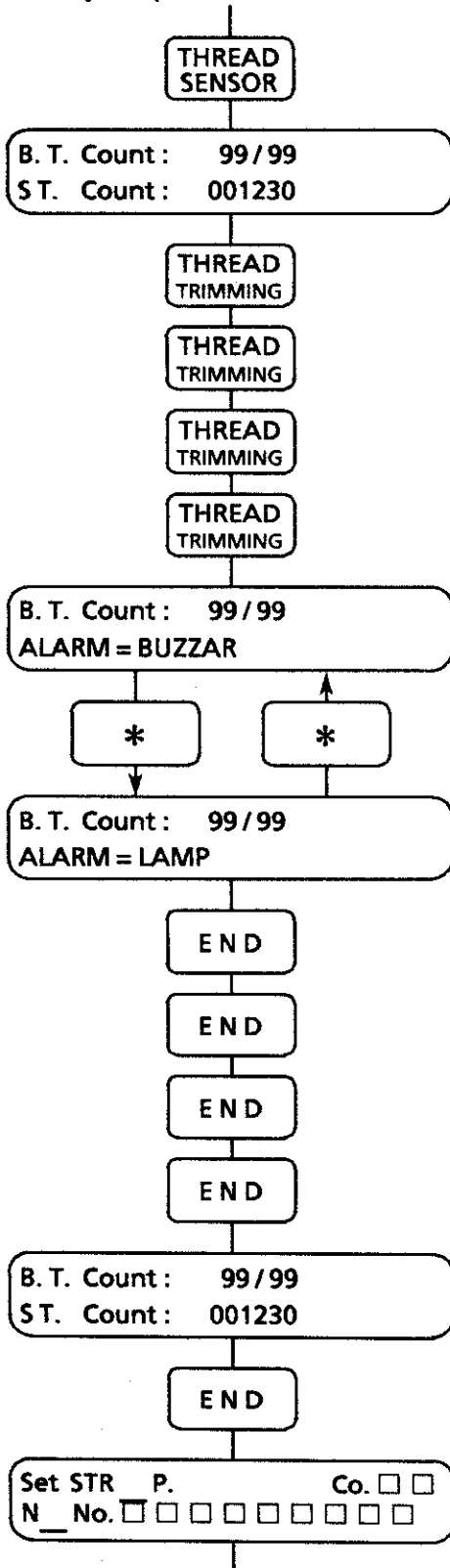

1. Press <THREAD SENSOR> key.

Bobbin thread counter, thread breakage sensor setting mode display

2. After setting is completed, press the <THREAD TRIMMING> key four times.

3. Each time <*> key is pressed, the display changes to show Buzzar and Lamp alternately.

4. After setting is completed, press the <END> key four times.

Bobbin thread counter, thread breakage sensor setting mode display.

5. Press the <END> key to return to embroidery mode.

13. Thread trimmer operation activation/ deactivation setting function

The operation of the thread trimmer can be activated or deactivated from the operation panel.

NOTE: If thread trimmer operation is deactivated, thread trimming will be deactivated at all times.

The way to operation

Previous display

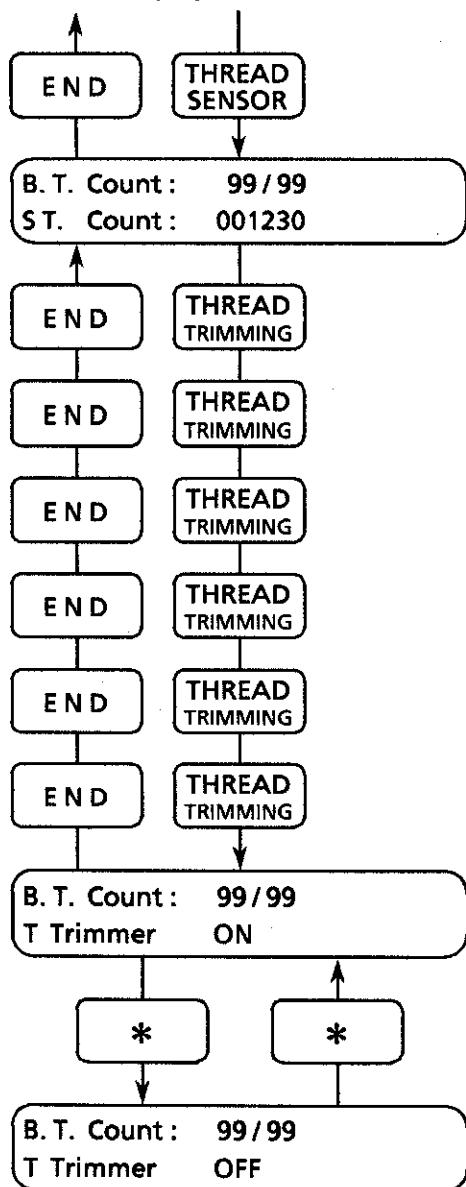

1. Press <THREAD SENSOR> key.

Bobbin thread counter, thread breakage sensor setting mode display

2. After setting is completed, press the <THREAD TRIMMING> key six times.

3. The thread trimmer is switched on and off each time the <*> key is pressed.

14. Mask check activation/ deactivation setting function

Mask checking and outline tracing operations can be activated or deactivated from the operation panel.
NOTE: If these operations are deactivated, sewing will be carried out regardless of the size of the pattern.
 Because of this, there is the danger that the pattern might go outside the edge of the frame.

The way to operation

Previous display

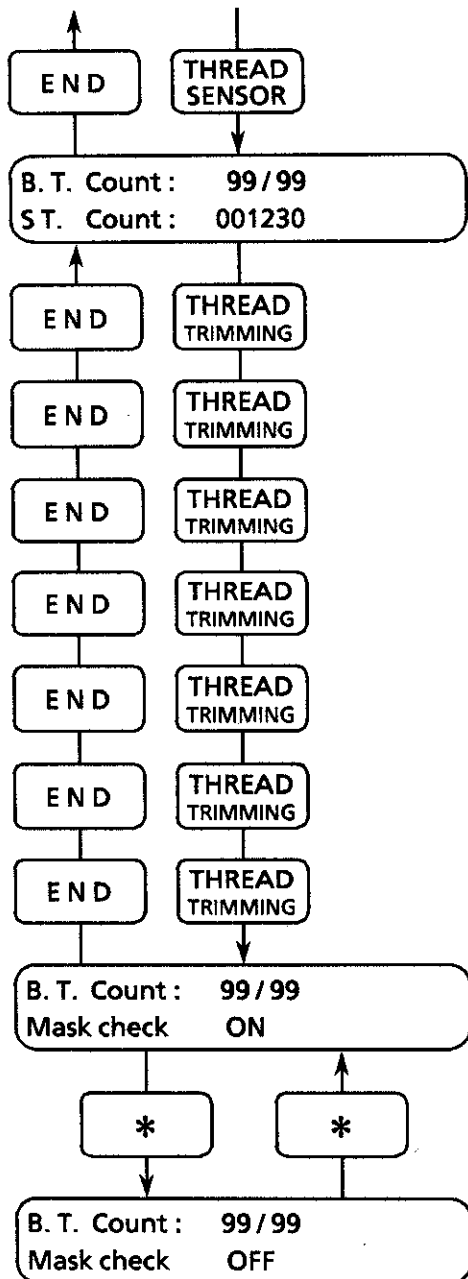

1. Press <THREAD SENSOR> key.

Bobbin thread counter, thread breakage sensor setting mode display

2. After setting is completed, press the <THREAD TRIMMING> key seven times.

3. The thread trimmer is switched on and off each time the <*> key is pressed.

Chapter 8.

Connection and Installation of Optional Equipment

1. Tape reader

NOTE: Connect them using RS cable assembly (optional).

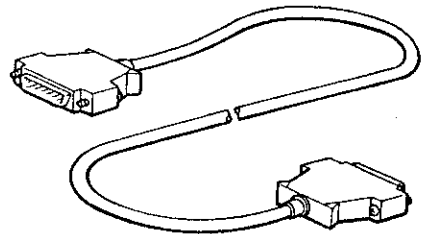
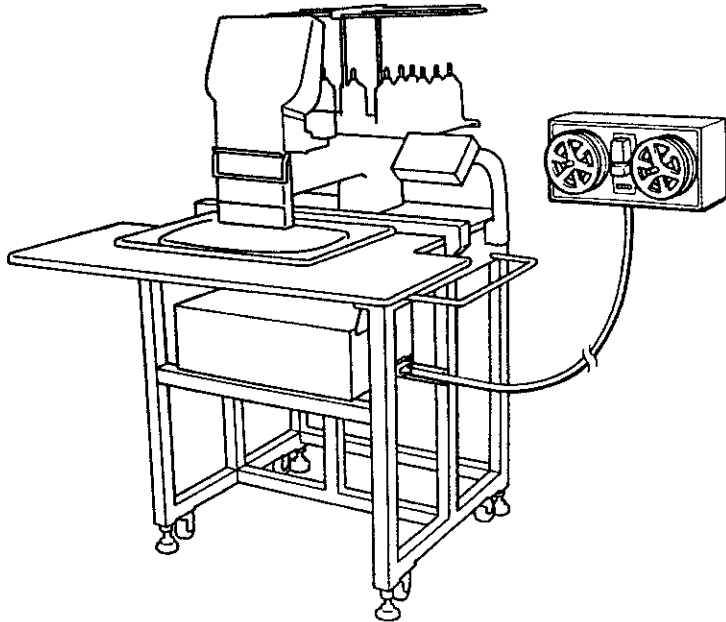

■ Connecting cable with machine

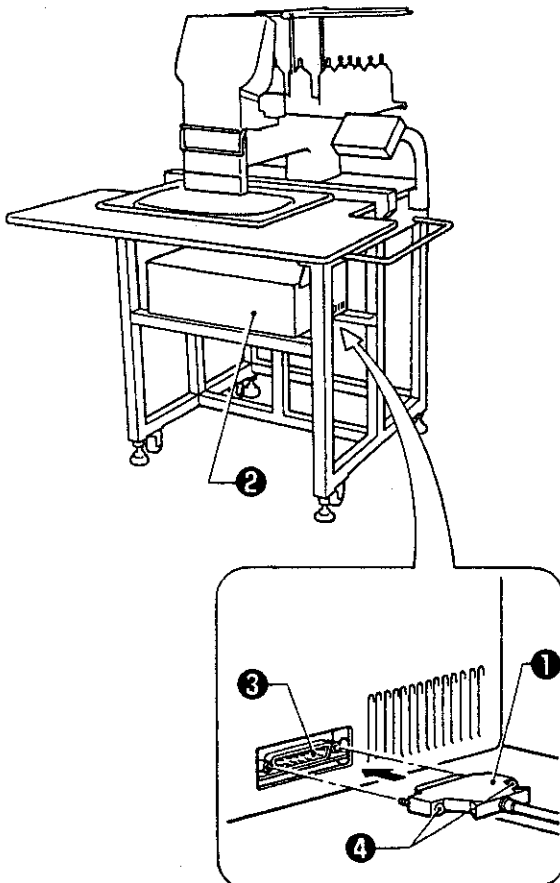

Connect the connector (either of the two may be used) of the RS cable assembly ① (optional) with the connector ③ on the circuit board ②. Secure the two screws ④.

■ Connecting the cable with the paper tape reader

Connect the connector of the RS cable assembly (optional) with the RS232C connector of the paper tape reader.

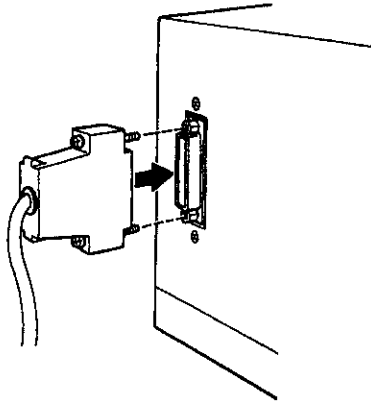

■ Operating and preparing paper tape reader

* Prepare the machine. (Turn on the power and select "paper tape" in the communication mode.)

[GNT27]

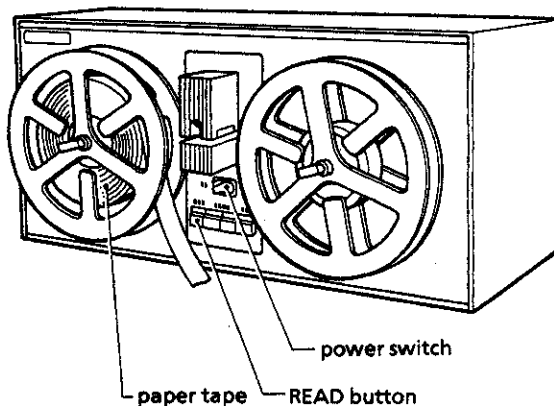

1. Turn on the power of the paper tape reader.
2. Thread the paper tape to the paper tape reader.
 - For GNT27:
Turn the "READ" button ON (indicator lights).
 - For GNT4604:
Turn the "READER" button ON and set the mode switch on the operation panel to "LINE".
 - For NPR-5200:
Turn the "LINE" button ON (indicator lights).
 - For GNT2910:
Turn the power ON.
3. Now that the paper tape reader is ready:
Press the <ENTER> key of the machine to begin.

NOTE: If using the GNT4604, set the mode switch on the operation panel to "LINE".

■ Notes for paper tape reader

NOTE: Use only the paper tape readers in the table below for BAS-416A · BES-1210AC.
Do not use other paper tape readers. Others may not interface with BAS-416A · BES-1210AC or cause trouble.

Maker	Production code	Interface specification (Connector type)	RS cable type (optional)
GN Telecom Inc.	GNT27	RS232C interface (female)	GNT 27 RS cable assembly Code: S17064-001 and RS cable assembly Code: S15406-001
	GNT4604	RS232C interface (DCE connector female)	RS cable assembly Code: S15406-001
		RS232C interface (DCE connector male)	GNT4604 cable assembly Code: S18957-001 and RS cable assembly Code: S15406-001
	GNT2910	RS232C interface (pin 9 male)	GNT2910 cable assembly Code: S21660-000 and RS cable assembly Code: S15406-001

- Set the paper tape reader switches as follows for BAS-416A · BES-1210AC.

- ① Character length 8 bit
- ② Stop bit length 1 bit
- ③ Baud rate 9,600 baud (for 4,800 baud-paper tape reader, refer to page 37, "Dip switch functions on main printed circuit board").

- Among paper tape readers that can be connected with the BAS-416 · BES-1210AC, BROTHER deals in the following paper tape reader as an option. (Contact Brother's shop for details.)

maker	type	name	part code	Vol. Spec.
GN Telecom Inc.	GNT27	GNT27-100V assembly	S18444-000	AC120V- area or 240V-area AC220 - 240V-area (in Europe)

- NOTE:
- When you purchase above paper tape reader GNT27; GNT27RS cable assembly (S17064-001) comes with it.
 - Three switches on the paper tape reader, ①②③, are already set at shipping.
 - Of the set points ①, ② and ③, only ③ (baud rate) can be changed on the machine. Refer to page 37 "Dip switch functions" for details.

2. Bobbin winder (Option)

■ Attaching bobbin winder

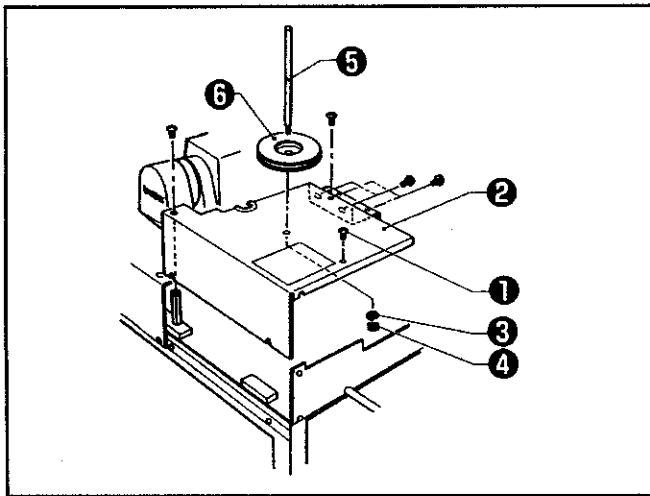

1. Loosen the four screws ❶ and remove table (L) ❷.
2. Attach spool shaft (B) ❸ to table (L) ❷ with the washer ❹ and the nut ❺. Attach table (L) ❷ to the machine body with the four screws ❶.
(Pass spool mat (A) ❻ through spool shaft (B) ❸.)

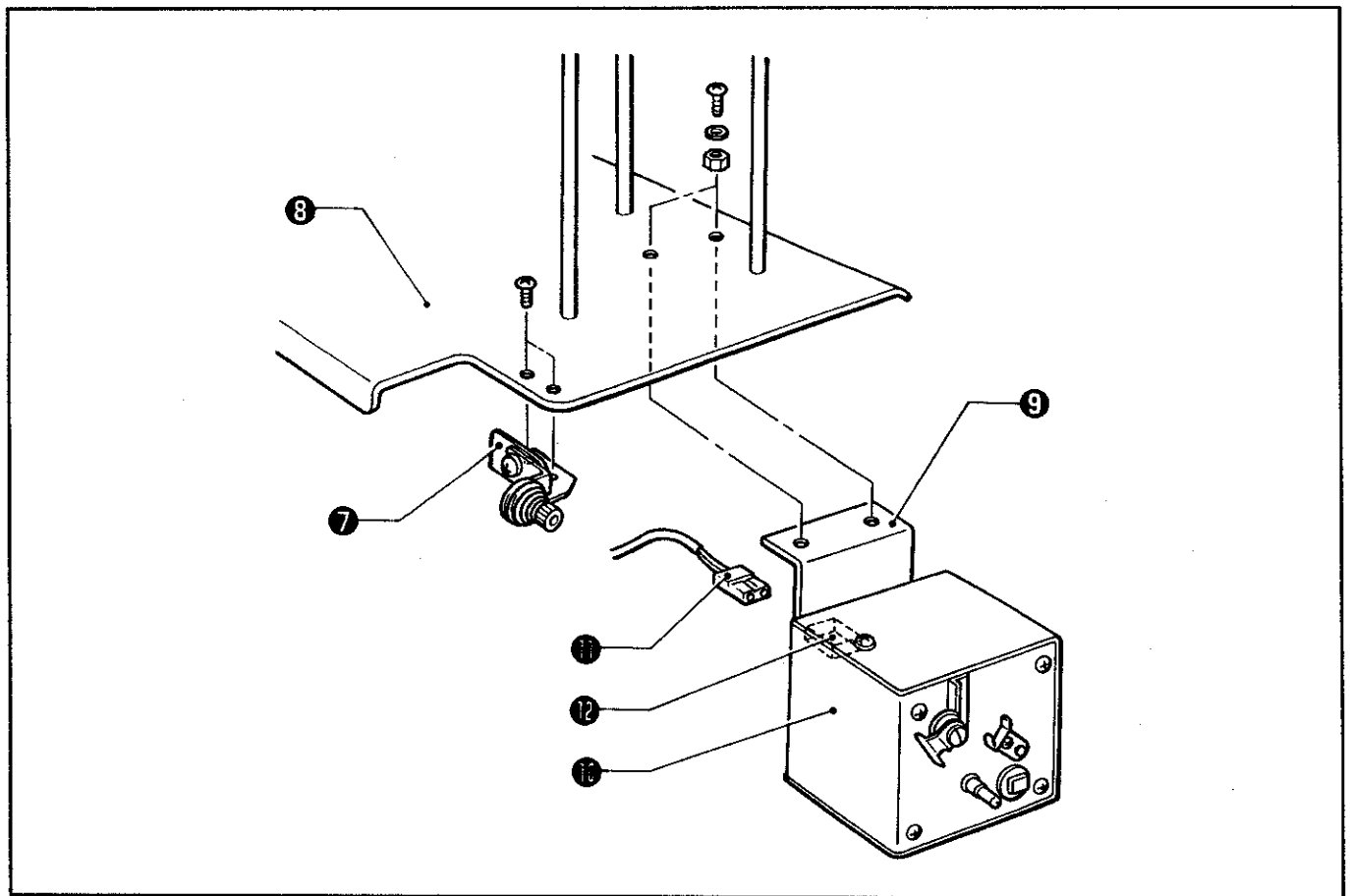

3. Attach the bobbin winder guide bracket assembly ❷ to the spool stand ❸ with the screws.
4. Attach the bobbin winder equipment assembly ❿ with bobbin winder plate ❸ to the machine body with the two bolts, washers and nuts, and then connect the bobbin winder equipment connector ❻ to the nylon connector ❶.

■ Winding bobbin thread

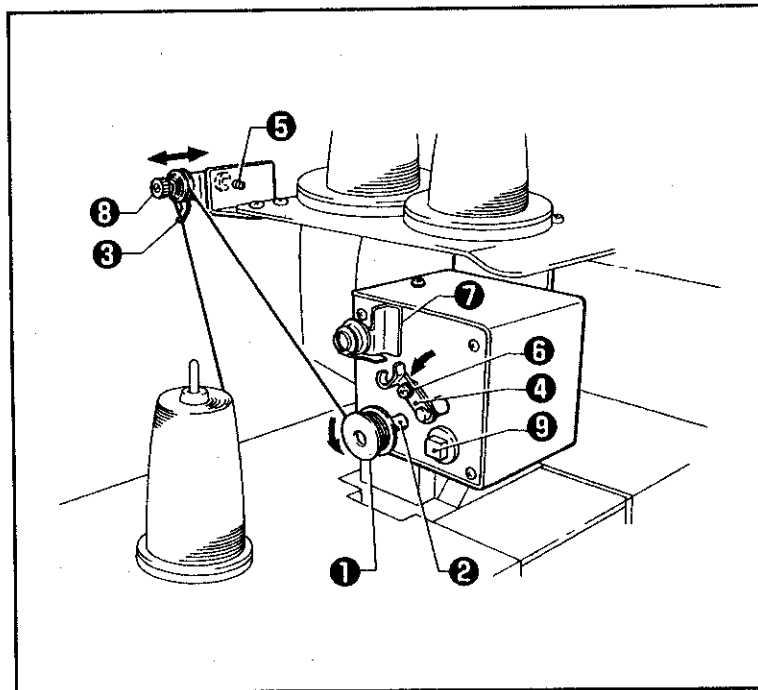

1. Turn on the power.
2. Press the bobbin ① on the bobbin winder shaft ②.
3. Pass the thread through the thread guide ③.
4. Wind the thread on the bobbin ① several times in the direction of the arrow.
5. Press the bobbin presser ④.
NOTE: If the thread is not wound evenly on the bobbin, loosen the screw ⑤ and move the thread guide ③ right and left. When winding more thread on the bobbin, loosen the screw ⑥, then move the bobbin presser ④.
6. When the winding is finished, remove the bobbin from the bobbin winder shaft and trim the thread with the thread trimmer ⑦.
NOTE:
 - If the thread comes out from the thread guide ③, loosen the knob ⑧. If the thread is wound too loose, tighten the knob ⑧.
 - The thread winder motor does not operate if the circuit protector activated. In that case, leave the protector until it's cooled off. Then, press the protector switch ⑨. If the protector is not cooled off, the switch does not work.

Chapter 9. Maintenance

1. Cleaning

Keep the machine clean and unclogged to prevent machine trouble.

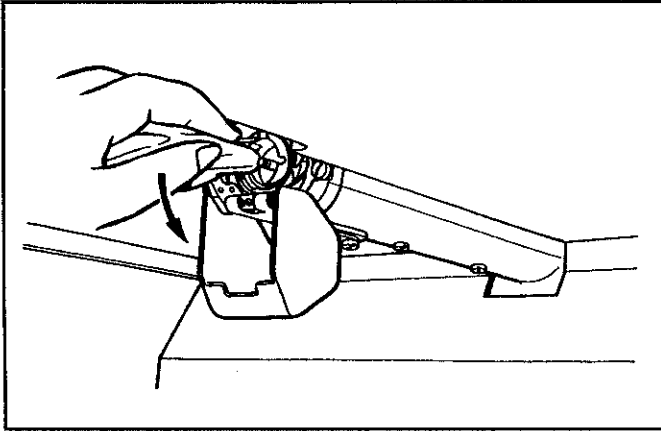

Keep the machine clean:

Remove dirt with a soft, dry cloth. If necessary, clean with the detergent-soaked cloth, then wipe off the detergent with a cloth dampened with (hot) water.

Caution:

Do not clean with benzene, thinner, or other volatile solvents.

Before working the machine, move the needle bar case all the way to the right and left, and remove oil and dirt around the needle bar guide rail and the shaft of the presser foot from the back of the needle bar case using a cloth.

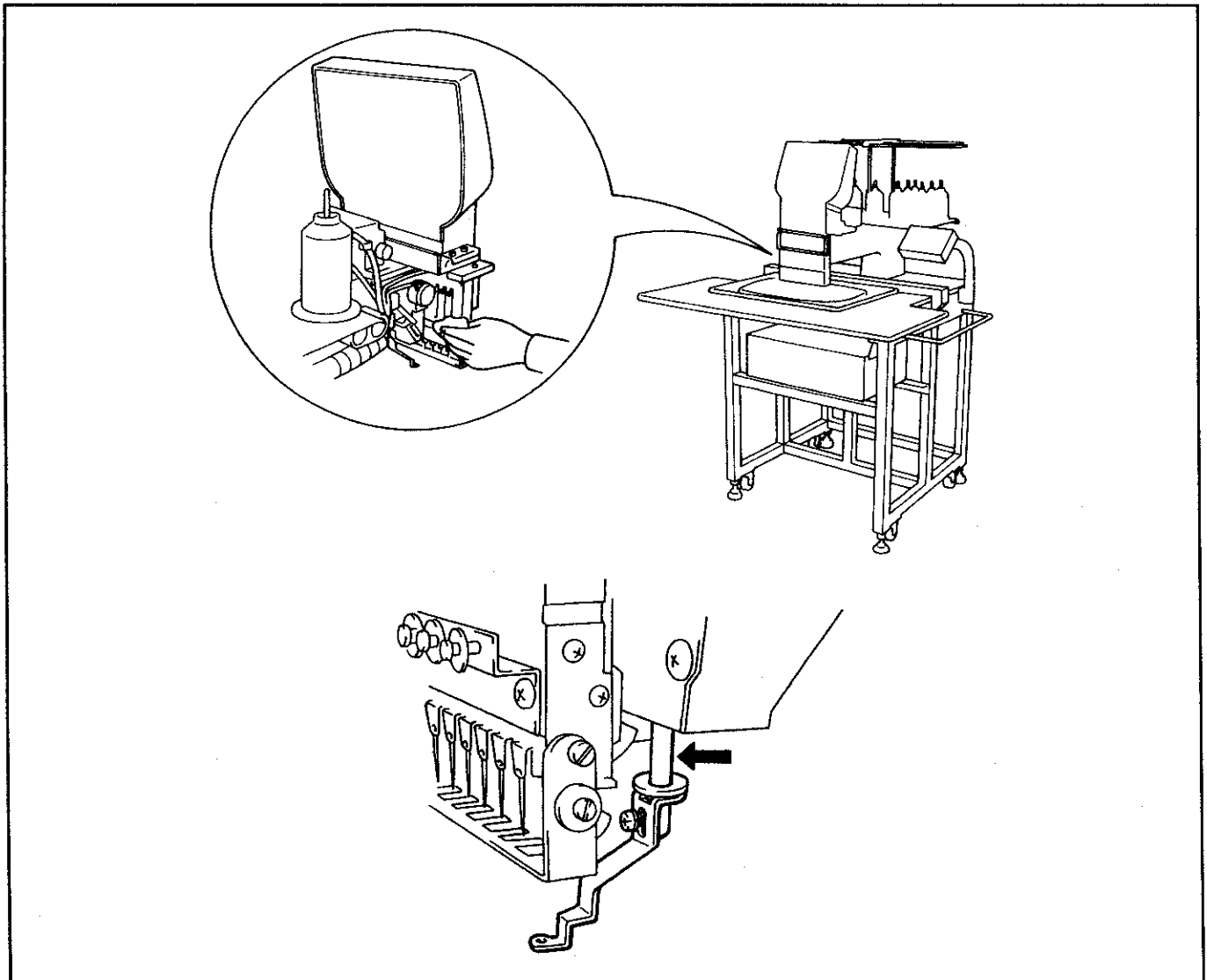

2. Oiling

Lubrication is necessary for keeping the machine in good condition.

The BAS-416 oil system uses a wick. Every day before using the machine, add 1-2 drop(s) of oil at the point indicated by each arrow in the figure.

NOTE: Be sure to use only Brother-specified sewing machine oil, Brother or Sewing Lub 10 for lubrication.

1. Add oil at each point indicated by the arrow when the machine is used for the first time after unpacking or if left unused for a long period of time.

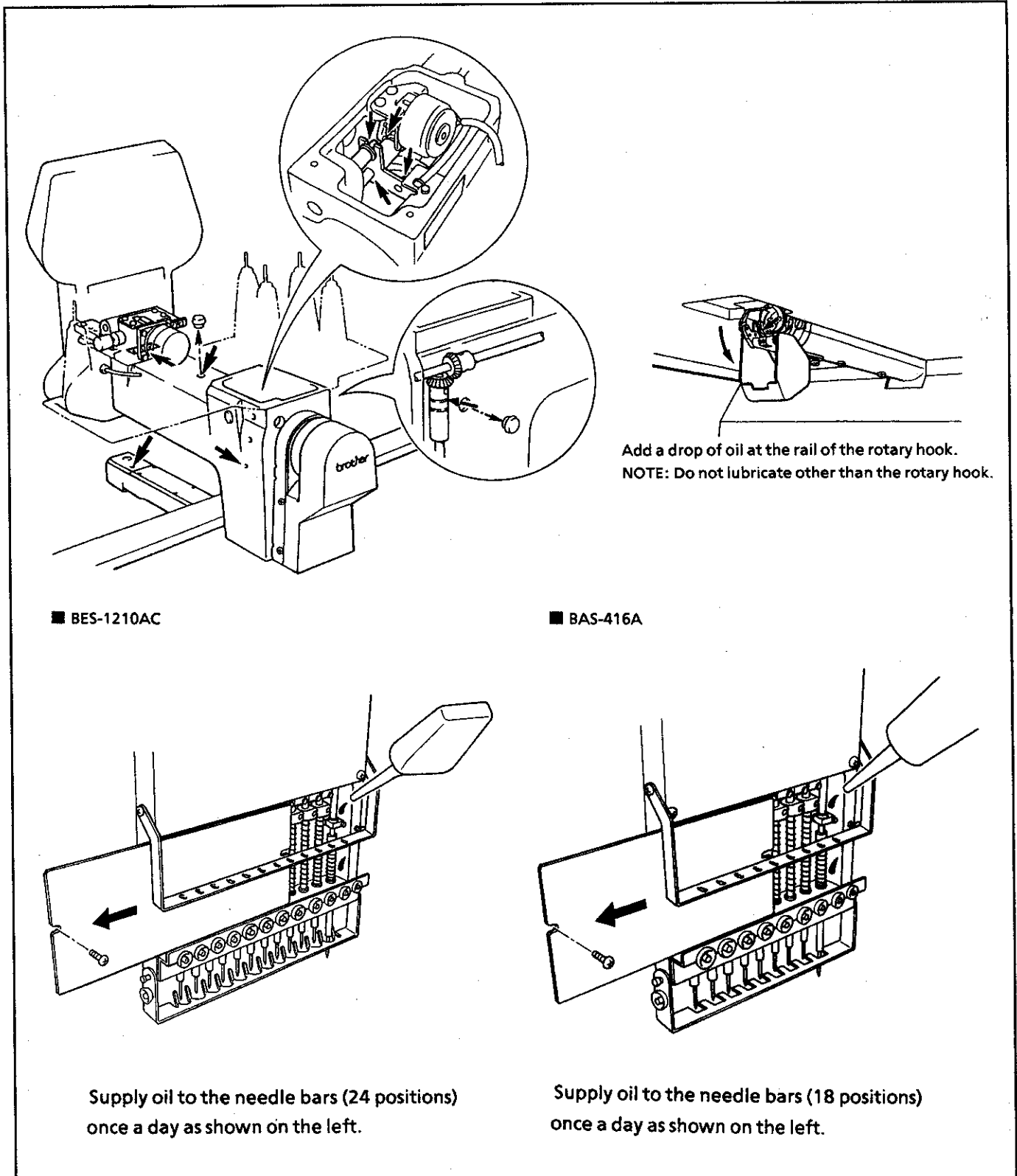

2. Every day before using the machine, add 1-2 drop(s) of oil at the points indicated by each arrow in the figure.
 - Oil may run out in the tank after one or two hours of operation, but a part that can keep extra oil is incorporated into the machine front oil tank, so that even with no oil tank, oil can be supplied from this part little by little.

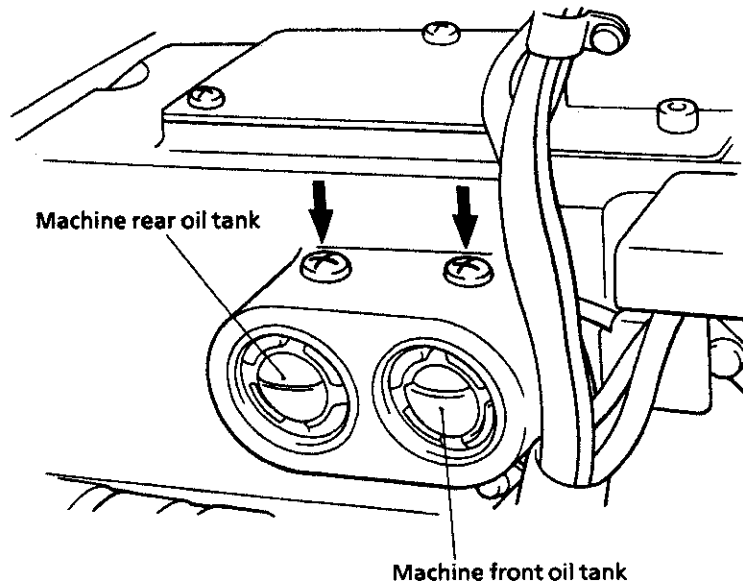

■ BES-1210AC

■ BAS-416A

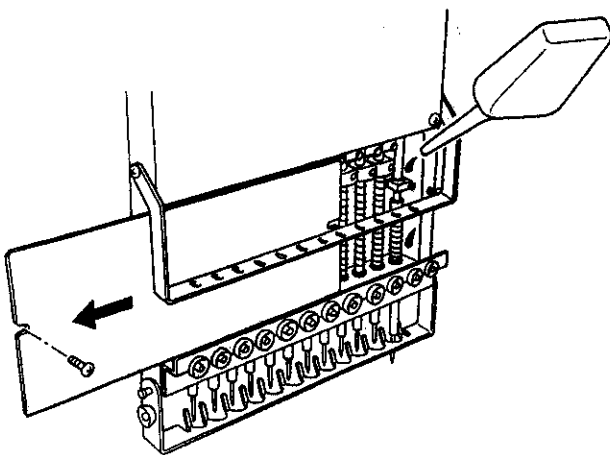

Supply oil to the needle bars (24 positions) once a day as shown on the left.

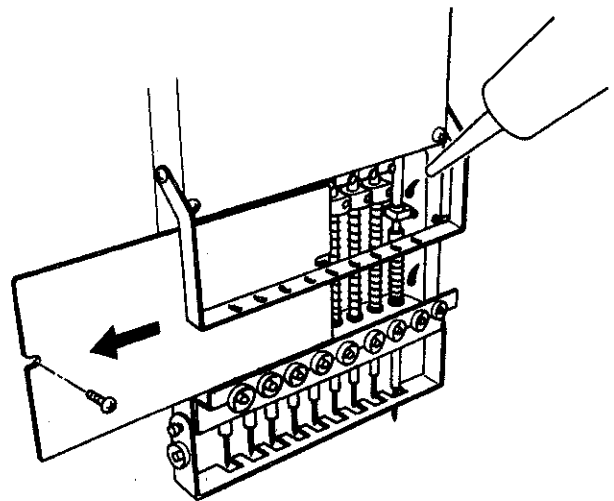

Supply oil to the needle bars (18 positions) once a day as shown on the left.

Chapter 10. Standard Adjustment

⚠ CAUTION



Turn off the power switch and pull out the plug before starting adjustment. Failure to do so may start the machine unintentionally through an accidental activation of the START switch, resulting in bodily injuries.

- Adjustment



If adjustment should be made while the power switch is turned on, pay special attention to your safety.



Maintenance and inspection of the machine should be conducted only by trained engineers.

1. Adjusting needle bar height

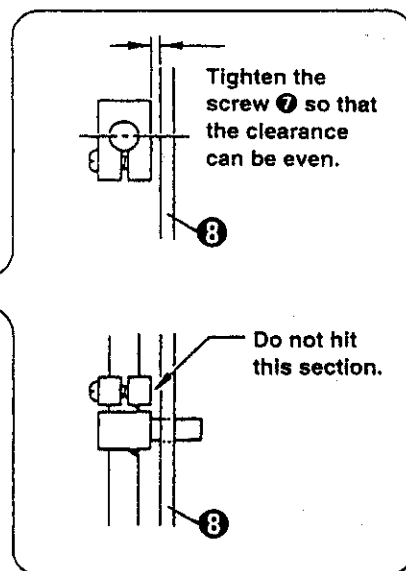
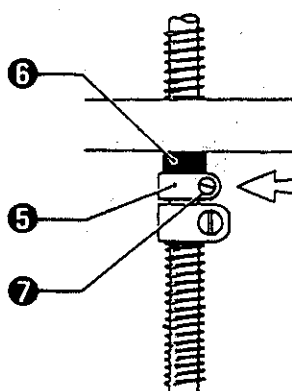
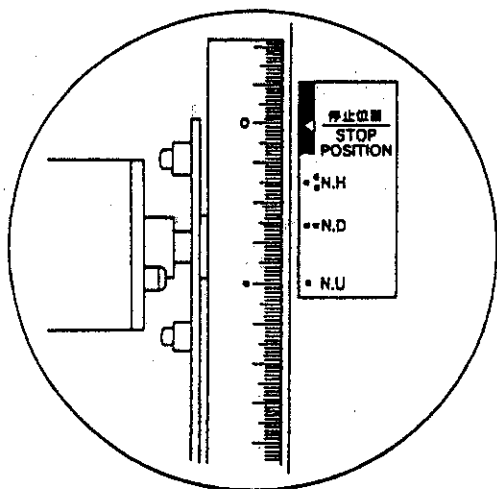
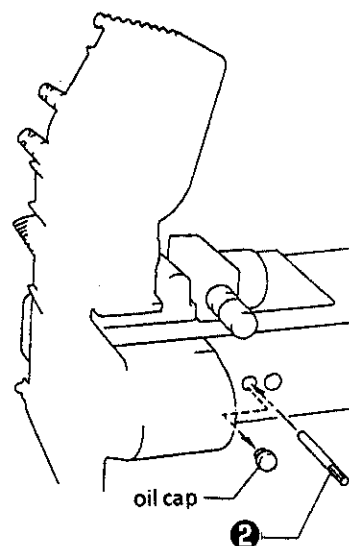
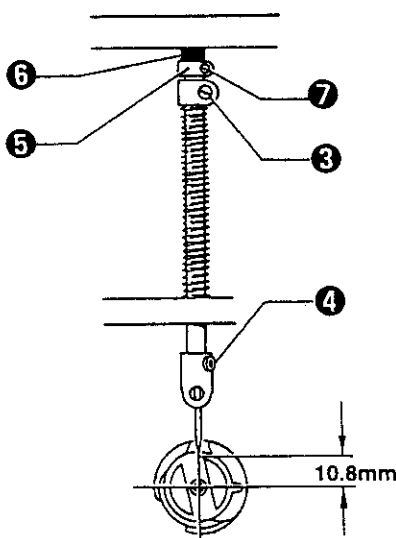
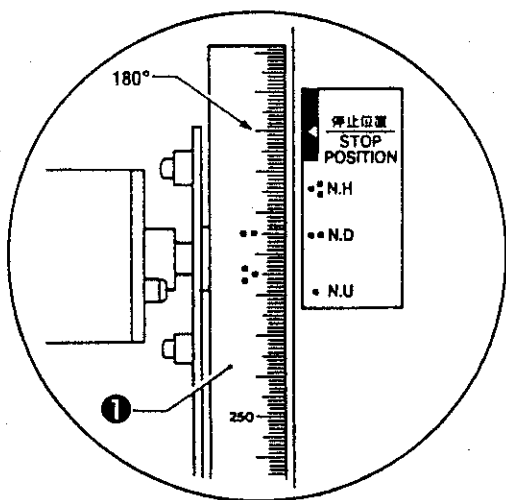

1. Dismount the pulley cover and turn the pulley ❶ until the pulley scale indicates 180° and the needle bar is set at the lowest position. (The pulley "■" mark and the stop mark "■" are aligned.)
2. Insert the positioning bar ❷ into the hole of the pulley ❶ and fix the drive shaft.
NOTE: Turn the pulley securely in the clockwise direction to eliminate a backlash.
3. Loosen the needle bar clamp set screw ❸ when the needle tip is positioned 10.8 mm above the center of the rotary hook shaft. Adjust the position of the needle bar thread guide so that the set screw ❹ on it is turned to the right by 25 - 30°. Tighten the needle bar clamp set screw ❸ securely.
NOTE: When tightening the needle bar clamp set screw ❸, the hole in the needle bar guide should face the front.
4. After adjustment is finished, remove the positioning bar ❷.
5. Set the needle bar at the highest position (where the pulley indication mark "■" and the cover indication mark "■" are aligned). Lightly press the top dead center stopper ❺ toward the cushion rubber ❻, and tighten the top dead center stopper screw ❼ while pressing down the needle bar clamp so that it faces the front.
NOTE: Make sure that the top dead center stopper does not hit the needle bar guide rail ❼ at this time.

■ When using the bottom dead center gauge

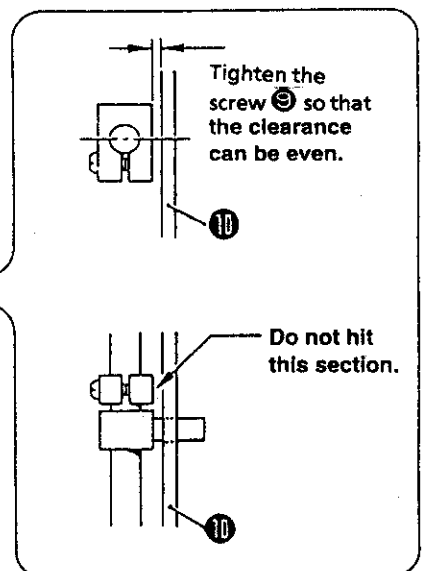
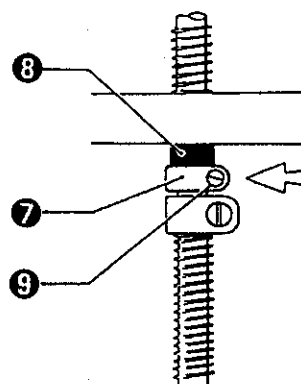
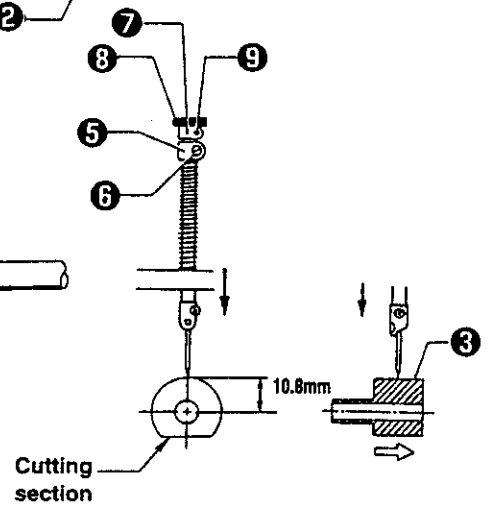
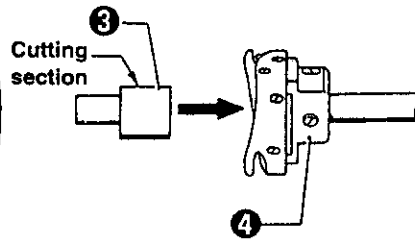
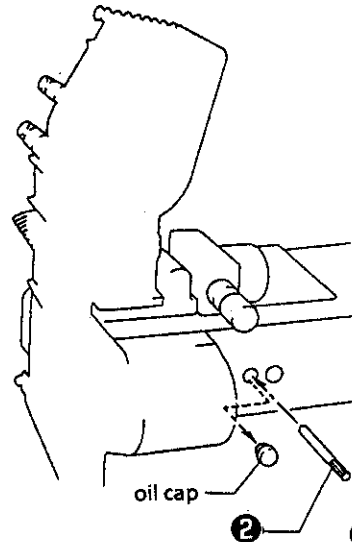
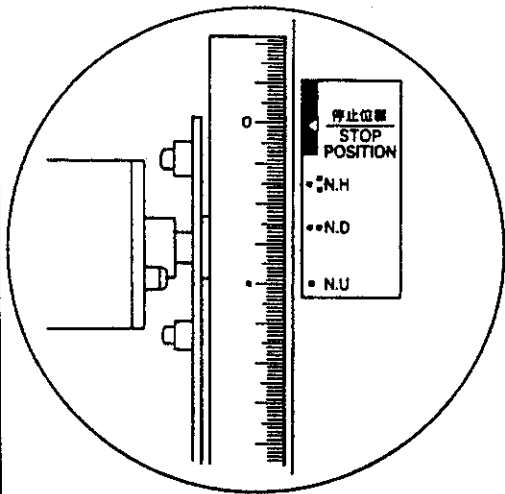
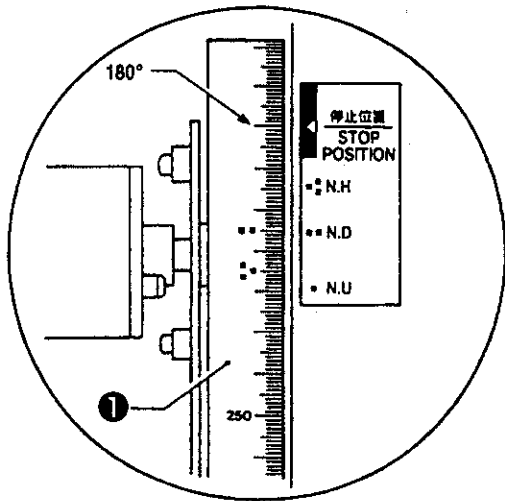

1. Turn the pulley ❶ until the scale of pulley ❶ indicates 180° (where the pulley indication mark "■" and the stop mark "■" are aligned) and the needle bar is set at the lowest position.
2. Insert the positioning bar ❷ into the hole of the pulley ❶ and fix the drive shaft.
NOTE: Turn the pulley securely in the clockwise direction.
3. Insert the bottom dead center gauge ❸ into the rotary hook ❹.
4. Loosen the screw ❺ of the needle bar clamp ❻ and move the needle bar up and down until the needle tip touches the gauge ❸ lightly.
NOTE:
 - The needle point should touch the gauge at a place other than the cutting section.
 - The bottom dead center gauge should be set in or removed from the rotary hook with its cutting section facing upward.
5. Tighten the screw ❺ of the needle bar clamp ❻ securely.
6. After adjustment is finished, remove the positioning bar ❷.
7. Set the needle bar at the highest position (where the pulley indication mark "■" and the cover indication mark "■" are aligned). Lightly press the top dead center stopper ❽ toward the cushion rubber ❾, and tighten the top dead center stopper screw ❾ while pressing down the needle bar clamp so that it faces the front.
NOTE: Make sure that the top dead center stopper ❽ does not hit the needle bar guide rail ❿ at this time.

2. Adjustment of timing between needle and rotary hook

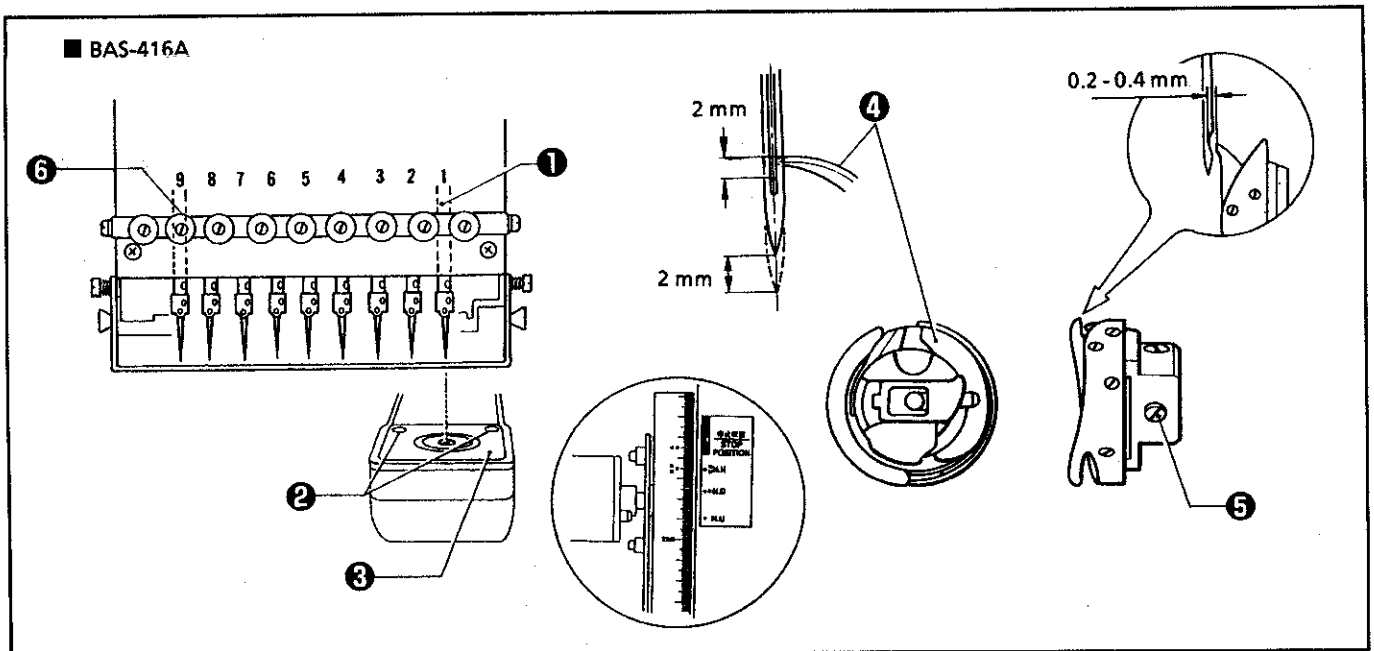

1. Turn the power switch off.
 2. Select the needle bar No. 1 ① .
The illustration at the left shows the case of BAS-416A. For BES-1210AC, the No. 12 needle becomes 6.
 3. Remove two flat screws ② and dismount the needle plate ③.
 4. Loosen the set screws ⑤ of the rotary hook ④, and adjust the rotary hook ④ position so that the needle point meets the rotary hook ④ point when the needle bar is raised 2 mm above its lowest position (when ■ mark on the pulley is aligned with the one on the belt cover). Then tighten the set screws ⑤. At this time, the needle bar height should be approximately 2 mm.
 5. Adjust the clearance between the needle and the rotary hook's point to 0.2 - 0.4 mm at the needle bar No. 9 ⑥ (No. 12 needle for BES-1210AC).
- NOTE: If the clearance between the needle and the rotary hook's point is not within the range of 0.2 - 0.4 mm, adjust again as described in step ④ until the clearance between the needle bar No. 1 or No. 9 (No. 12 for BES-1210AC) and the rotary hook's point becomes within 0.2 - 0.4 mm.

3. Adjustment of presser foot height

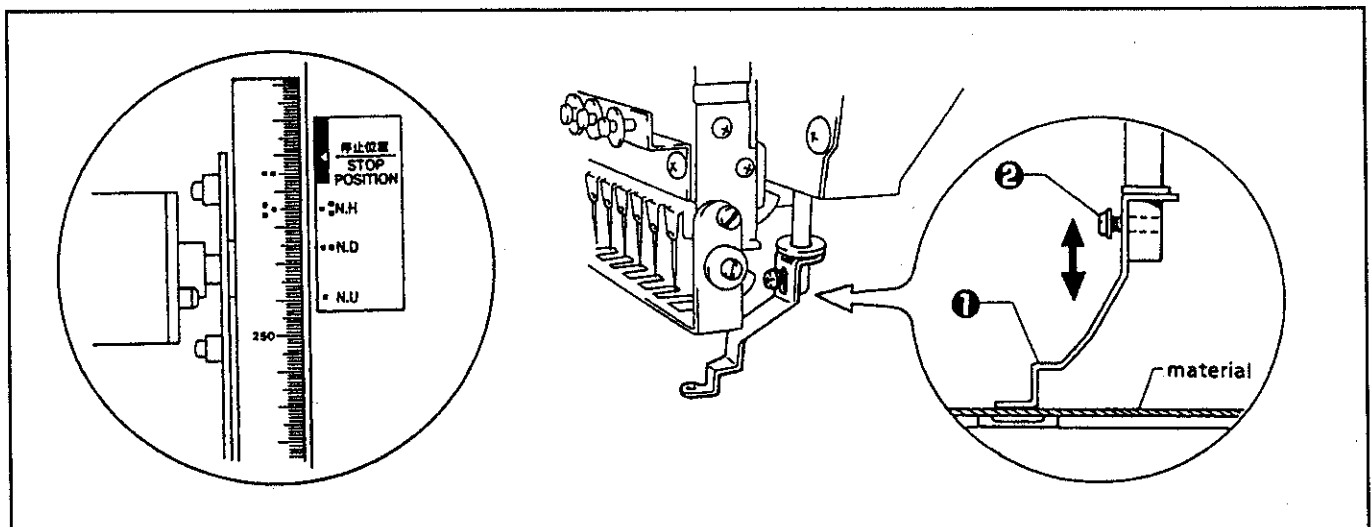

1. Turn the power switch off.
2. Select the needle bar No. 1.
3. Loosen the screw ② of the presser foot ①, and adjust the presser foot ① until it comes above the cloth top surface when it is at the bottom dead center (where the pulley indication mark "■" and the cover indication mark "■" are aligned).
4. Turn on the power and lower the presser foot ① using the lever.

4. Adjusting the belt tension

The belt tension is adjusted to the optimum tension at the time of shipment from the factory. However, as the belt is used, it becomes run in and may loosen around the machine pulley and motor pulley. Use the following procedure to check the belt tension.

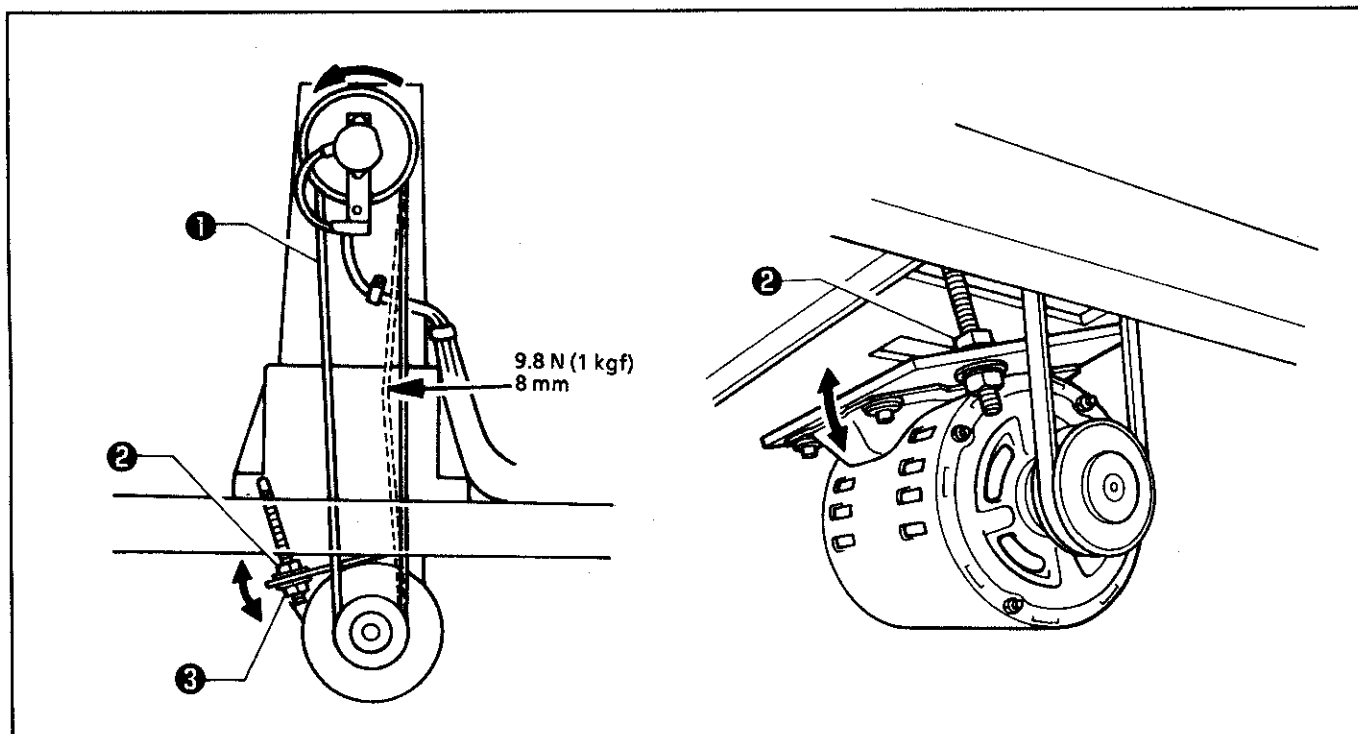

Place a gauge against the belt ①, loosen the nut ② and then turn the nut ③ so that there is 8 mm of deflection in the belt ① when 9.8 N (1 kgf) of pressure is applied.

- The machine operating direction is counterclockwise when seen from the machine pulley end.

Chapter 11.

Error Messages

Refer to the table below if an error message is displayed.

By pressing the <CLEAR> key, the message will disappear and the display will return to the previous menu.

Message when power is turned on	Cause	Solution
Keyboard ROM NG.	CPU version of key board does not match PROM version of PCB.	Change CPU version of key board, to proper version matching PROM. Contact your dealer.
Needle POS. Error	Pulley is not in proper position.	Turn pulley till needle bar is in proper position.
X__ORG. Error Y__ORG. Error	Damaged circuit board, sensor defective, cable defective, pulse motor defective, blown fuse.	Contact your dealer.
Over travel (In cap frame mode only)	<ul style="list-style-type: none"> • X carriages movement exceeds maximum area. • Overtravel sensor is in incorrect position or defective. • X home position sensor is in incorrect position or defective. • Damaged circuit board. 	Turn power off. Move carriages X to center of area manually, then turn power on again. If the same error message is displayed again, turn the power off, and then while pressing the <▽> key, turn it on again. Then press the <CLEAR> key.
Memory CLEAR	Back-up data in the memory disappears.	Press key according to message.
N__Case POS. Error	Needle bar is not set properly.	Position needle bar case properly. (Refer to page 34.)

Message in entry mode	Cause	Solution
No File	Data not registered in the floppy disk is entered.	Check file name of data and re-enter.
Data ERR.	Input data has something wrong.	Check where data was made, then contact your dealer.
Disk ERR.	<ul style="list-style-type: none"> • Data is input without inserting floppy disk. • While reading data, floppy disk is removed when machine runs in sewing mode. • Damaged circuit board, defective cable, defective FDD. 	Insert floppy disk in proper position and re-enter. Do not remove floppy disk from FDD during sewing in this mode. Contact your dealer.
Memory over	Too much data, or too many stitches of a data is over inside memory capacity and cannot manage it.	If memory expansion board (optional) is not set, set memory expansion board or decrease input data.

Message in editing mode	Cause	Solution
Can-'t edit Data	<ul style="list-style-type: none"> • Some of data entered in communication mode has items that cannot edit. • Some of data entered in sewing mode while reading data has items that cannot edit. • According to editing item, there is item that cannot be set. 	Refer to page 67.

Message in sewing mode	Cause	Solution
No inpttd Data	Without sewing data entered, you try to set machine to sewing mode.	First, input sewing data, then start sewing.
Short of Area	Entered value exceeds maximum area (450 mm x 300 mm).	This data cannot be sewn.
Data ERR.	Entered data has something wrong.	Check where data was made, then contact your dealer.
Area Over	When sewing starts from current needle position, sewing pattern is over area.	Move the hoop to position where message disappears, or spread area.
B.Thread empty	The set sewing times in bobbin thread counter is completed.	Reset sewing times in bobbin thread counter.
Thread breakage	<ul style="list-style-type: none"> • Upper thread breakage. • Thread is not wound on thread breakage detector. • Bobbin thread breakage • Bobbin thread has run out. 	Set thread.
Motor Lock	<ul style="list-style-type: none"> • Pulley is too tight. • Electrical failure 	Remove load. Contact your dealer.

Message in communication mode	Cause	Solution
Off line	<ul style="list-style-type: none"> • Paper tape reader or editing system does not connect with machine by cable. • Power of paper tape reader or editing system is not turned on. • Editing system does not enter communication mode. • Editing system is communicating with an other machine. 	<p>Link with dedicated cable.</p> <p>Turn on power.</p> <p>Set editing system to communication mode.</p> <p>Wait till communication ends.</p>

Message in communication mode	Cause	Solution
Line ERR.	<ul style="list-style-type: none"> • Data error occurs during communicating with editing system. • Editing system exits from communication mode while machine is communicating with editing system. • Power of editing system is turned off during communicating. 	<p>Re-communicate.</p> <p>Set editing system to communication mode, then communicate again.</p> <p>Turn on power of editing system again, enter communication mode.</p>
Line Busy	Editing system is defective, or breakdown.	<p>Turn on power of editing system again, enter communication mode.</p> <p>Contact your dealer.</p>
Tape read Error	<ul style="list-style-type: none"> • Poor punch of paper tape. • Paper tape runs short. • Dirty head of paper tape reader. • Power of paper tape reader is not turned on. • Paper tape type is wrongly selected. • Improper communication baud rate. 	<p>Remake paper tape.</p> <p>Clean head.</p> <p>Turn on the power.</p> <p>Select proper type to read paper tape.</p> <p>Adjust baud rate.</p>

Message in replacing needle bar	Cause	Solution
N__ Case POS. Error	<ul style="list-style-type: none"> • Needle bar is not set properly. • Damaged circuit board. 	<p>Position needle bar case properly. (Refer to page 27.)</p> <p>Contact your dealer.</p>
N__ Case Lock	<ul style="list-style-type: none"> • Needle bar case is too tight mechanically, or locked and cannot move. • Electrical failure 	<p>Remove load.</p> <p>Contact your dealer.</p>

Chapter 12.

Troubleshooting

In case of a malfunction, diagnose the problem referring to the table below.
If the problem persists, turn off the power and contact your dealer.

Problem	Check point
1. The display is blank, though power is on.	Is contrast dial properly adjusted?
2. The indicator does not light, though a floppy disk is in disk drive.	<ul style="list-style-type: none"> • Is floppy disk damaged? • Is disk drive functioning properly?
3. Thread breakage	<ul style="list-style-type: none"> • Is machine properly threaded? • Is thread tension too high? • Is rotary hook assembly clogged? • Is there thread in the bobbin? • Is needle bent? • Is there a rough edge or flaw on needle plate, rotary hook, or bobbin case that might cut the thread? • Is needle installed correctly? • Are the stitch density and thread thickness correct? • Are the thread thickness and needle size correct? • Is a thread with right-hand twist being used? (If a thread with right-hand twist is being used, replace it with a thread with left-hand twist.) • Is there anything on the needle such as adhesive? • Is the material tension too weak? • Is there too much play between the outer rotary hook and inner rotary hook? • Does the outer rotary hook turn smoothly? • Has the clearance between the rotary hook stopper and the outer rotary hook been adjusted correctly? • Does the thread come out from the bobbin case smoothly? • Is presser foot lowered fully?
4. Needle (presser foot) touches embroidery hoop	Is embroidery hoop too small?
5. Needle breaks.	<ul style="list-style-type: none"> • Is needle direction and height properly adjusted? • Is needle bent? • Is needle tip blunted? • Is timing of needle and rotary hook correct? • Is there looseness or play in the needle bar case? • Is rotary hook holder properly attached so that rotary hook does not rotate? • Is the needle thickness correct? Is the tip of the needle broken? • Does the needle pass through the center of the presser foot hole?

Problem	Check point
6. Monograms are not sewn properly.	<ul style="list-style-type: none"> • Is material edge caught in the machine? (Are embroidery hoop and other related parts operating correctly?) • Is material stretched properly? • Is thread tension proper? • Is the presser foot lifting up?
7. Machine operates incorrectly.	<ul style="list-style-type: none"> • Is set screw of rotary encoder loosened? • Is set screw of machine pulley loosened? • Is set screw of N65 pulley loosened? • Is synchronizer adjusted properly? • Are wires of carriages X and Y off? • Are set screws of wire drums X and Y loosened? • Are set screws of pinion gears in pulse motors X and Y loosened? • Is sewing data in floppy disk normal?
8. Upper shaft is locked at some point of a cycle.	<ul style="list-style-type: none"> • Is movable knife for thread trimming stopped in middle of operation? <p>[How to adjust]</p> <ul style="list-style-type: none"> • Remove thread or other interruption for good thread trimming operation. • Remove needle plate and reset it in proper position manually as in the figure below. <div data-bbox="921 1229 1219 1462" style="text-align: center;"> <p>knife</p> <p>1 mm</p> </div> <p>NOTE: When movable knife is in middle of operation, the safety system works so that the upper shaft cannot rotate.</p>

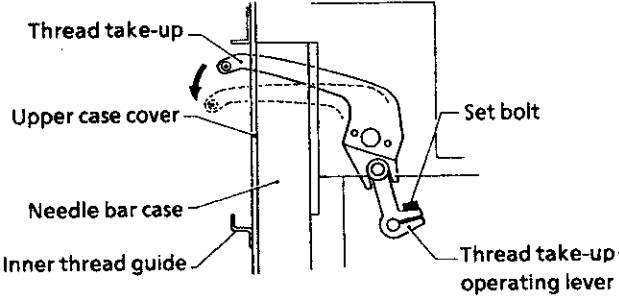
Problem	Check point
<p>8. Upper shaft is locked at some point of a cycle.</p>	<ul style="list-style-type: none"> Is thread take-up stopped with striking upper case cover? [How to adjust]  <p>Loosen the bolt of the thread take-up operating lever to adjust movable range of thread take-up, then re-tighten it.</p> <ul style="list-style-type: none"> Is position of needle bar clamp or stopper correct?
<p>9. Upper shaft does not turn.</p>	<ul style="list-style-type: none"> Is thread tangled in rotary hook? [How to adjust] <p>Remove rotary hook and see whether upper shaft rotates or not. If thread is tangled, turn upper shaft by force to trim thread or remove rotary hook and thread.</p> <ul style="list-style-type: none"> Is the presser foot still raised and at the shunting position?
<p>10. Stitch cannot be made.</p>	<ul style="list-style-type: none"> Is needle attached properly? Is timing of needle and rotary hook correct?
<p>11. When the power is turned on, the hoop moves till the hoop is over the sewing area.</p>	<p>Turn the power off, and then while pressing the <▽> key, turn the power back on again. Then press the <CLEAR> key.</p>
<p>12. When sewing is resumed in restart mode, the hoop moves till the hoop is over the area.</p>	<p>When there is a problem even if this is done, refer to "Flow chart" in the BAS-416A service manual.</p>
<p>13. Thread breakage detector functions and machine stops although thread breakage does not occur.</p>	<p>Is thread breakage detect stud operation normal? (Is spring tension proper?)</p>

Following is displayed when trying to read sewing data from a floppy disk while the floppy disk is inserted into the floppy disk drive.

- ① "Disk ERR." is displayed.
- ② "Data ERR." is displayed.
- ③ "Reading" is displayed and remains .

When another floppy disk is inserted, reading and sewing can be performed normally. The floppy disk drive may not be defective, but it is not clear what is wrong.

<Cause and solution >

(1) Floppy disk has not been previously defective.

If it occurs on the floppy disk which was able to use normally before, the floppy disk may be defective. (Repairing is impossible.)

Carefully deal with floppy disk. And for security, back up data on other storage medium, like personal computer, punching machine and so on.

(2) The floppy disk was originally defective.

If it occurs at a first-time use, the floppy disk may be originally defective.

Consult with shop you bought it or its maker.

(3) Following floppy disk cannot be used in BAS-416A · BES-1210AC even though it can be used in other embroidery machine.

When 3.5 2HD floppy disk was made in 2DD format.

When 3.5 2DD floppy disk was made in 2HD format.

If your problem does not come under case (1), (2) or (3), please consult with Brother's shop.

brother.

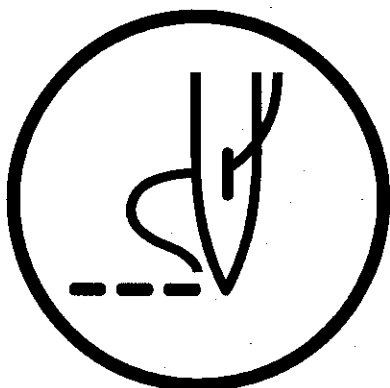

INSTRUCTION MANUAL

BROTHER INDUSTRIES, LTD. NAGOYA, JAPAN

Printed in Japan

155-C10, 416
S93C10-002
1998.08. H ①

Free Manuals Download Website

<http://myh66.com>

<http://usermanuals.us>

<http://www.somanuals.com>

<http://www.4manuals.cc>

<http://www.manual-lib.com>

<http://www.404manual.com>

<http://www.luxmanual.com>

<http://aubethermostatmanual.com>

Golf course search by state

<http://golfingnear.com>

Email search by domain

<http://emailbydomain.com>

Auto manuals search

<http://auto.somanuals.com>

TV manuals search

<http://tv.somanuals.com>