

Brother VX780

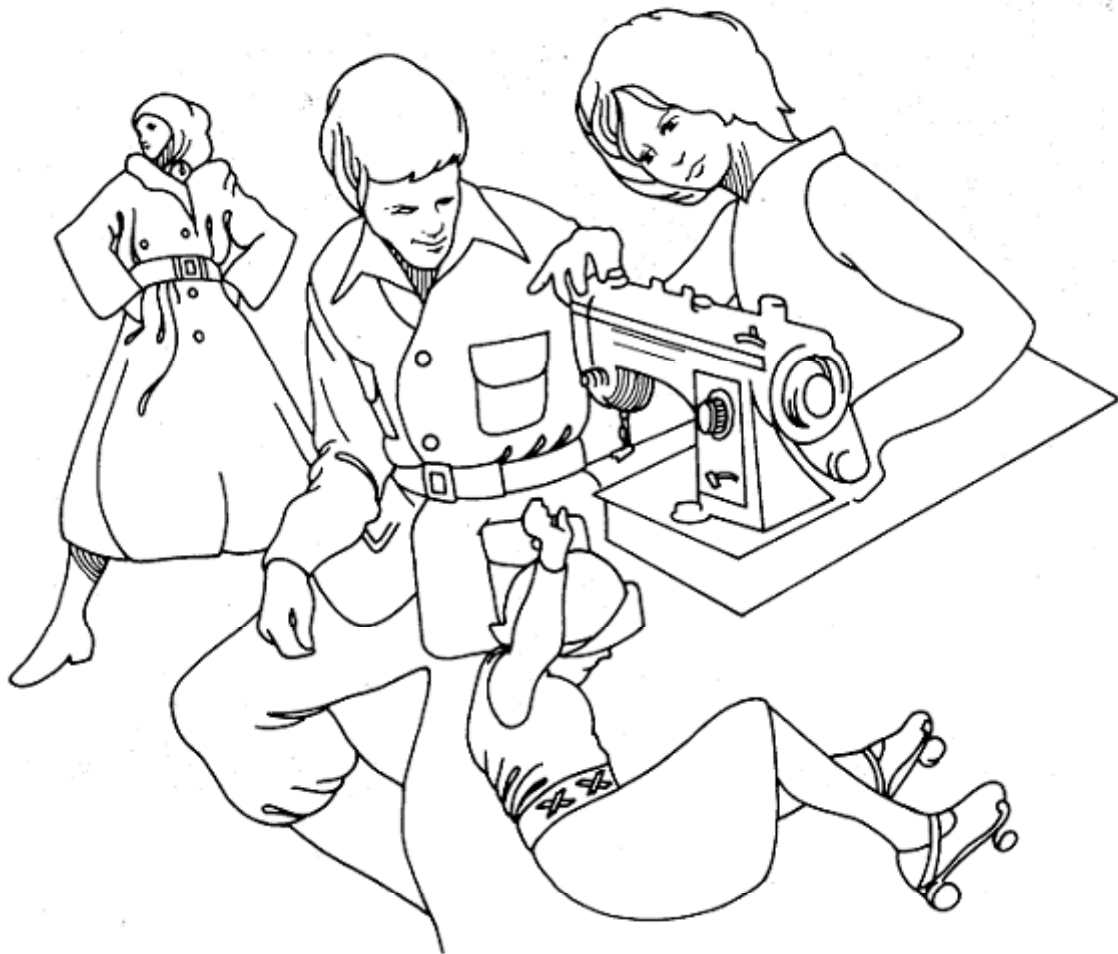

CAUTION

WHEN CHANGING NEEDLE, BOBBIN OR LIGHT BULB, OR WHEN SEWING MACHINE IS NOT IN USE, IT IS RECOMMENDED THAT ELECTRICAL SUPPLY PLUG IS DISCONNECTED TO AVOID ELECTRICAL HAZARDS.

CONTENTS

1. Knowing Your Sewing Machine	2	Simple zigzag stitch.....	19
PRINCIPAL PARTS.....	2	Satin stitch.....	19
MACHINE COVER.....	3	4. Decorative Stitches	20
ACCESSORIES.....	4	5. Built-in Stitches	21
OPERATING YOUR SEWING MACHINE.....	5	Triple stretch stitch.....	21
Connecting plugs.....	5	Shell stitch.....	21
Controlling sewing speed.....	5	Blind stitch.....	22
VARIOUS CONTROLS.....	6	Elastic stitch.....	23
Pattern dial.....	6	Link stitch.....	24
Stitch length dial.....	6	Elastic overlock stitch.....	24
Stitch width dial.....	7	Scallop stitch.....	25
Reverse sewing dial.....	7	6. Buttons and Button Sewing	26
Pressure adjuster.....	7	Buttonholes.....	26
PRESSER FOOT.....	8	Button sewing.....	28
NEEDLE.....	8	7. Attachments	29
How to change the needle.....	8	Zipper insertion.....	29
How to check the needle.....	8	8. Various Other Stitches	30
Twin needle.....	9	Gathering.....	30
RELATIVE CHART OF SEWING MATERIAL, NEEDLE AND THREAD.....	9	Attaching lace.....	30
SEW-LIGHT.....	10	Appliquéing.....	31
Sew-light switch knob.....	10	Cording.....	31
How to change the bulb.....	10	Darning.....	31
EXTENSION TABLE.....	10	Monogramming and embroidering.....	32
UPPER (NEEDLE) THREAD.....	11	9. Maintenance and Care of Your Machine	33
LOWER (BOBBIN) THREAD.....	12	Cleaning.....	33
How to wind bobbin.....	12	How to oil sewing machine.....	34
How to remove and insert bobbin case.....	13	Check list for better sewing.....	36
How to thread bobbin case.....	13	Replacing the machine.....	37
How to pull up lower thread.....	14	Index.....	38
THREAD TENSION.....	15	2. Straight Stitching	17
Upper thread tension.....	15	How to start sewing.....	17
Lower thread tension.....	15	How to change sewing direction.....	17
3. Zigzag Stitching	19	How to finish your sewing project.....	18
How to remove final sewing from machine.....	18	How to remove final sewing from machine.....	18
How to sew very thin material.....	18	How to sew very thin material.....	18
How to guide material.....	18	How to guide material.....	18

1 | Knowing Your Sewing Machine

Principal Parts

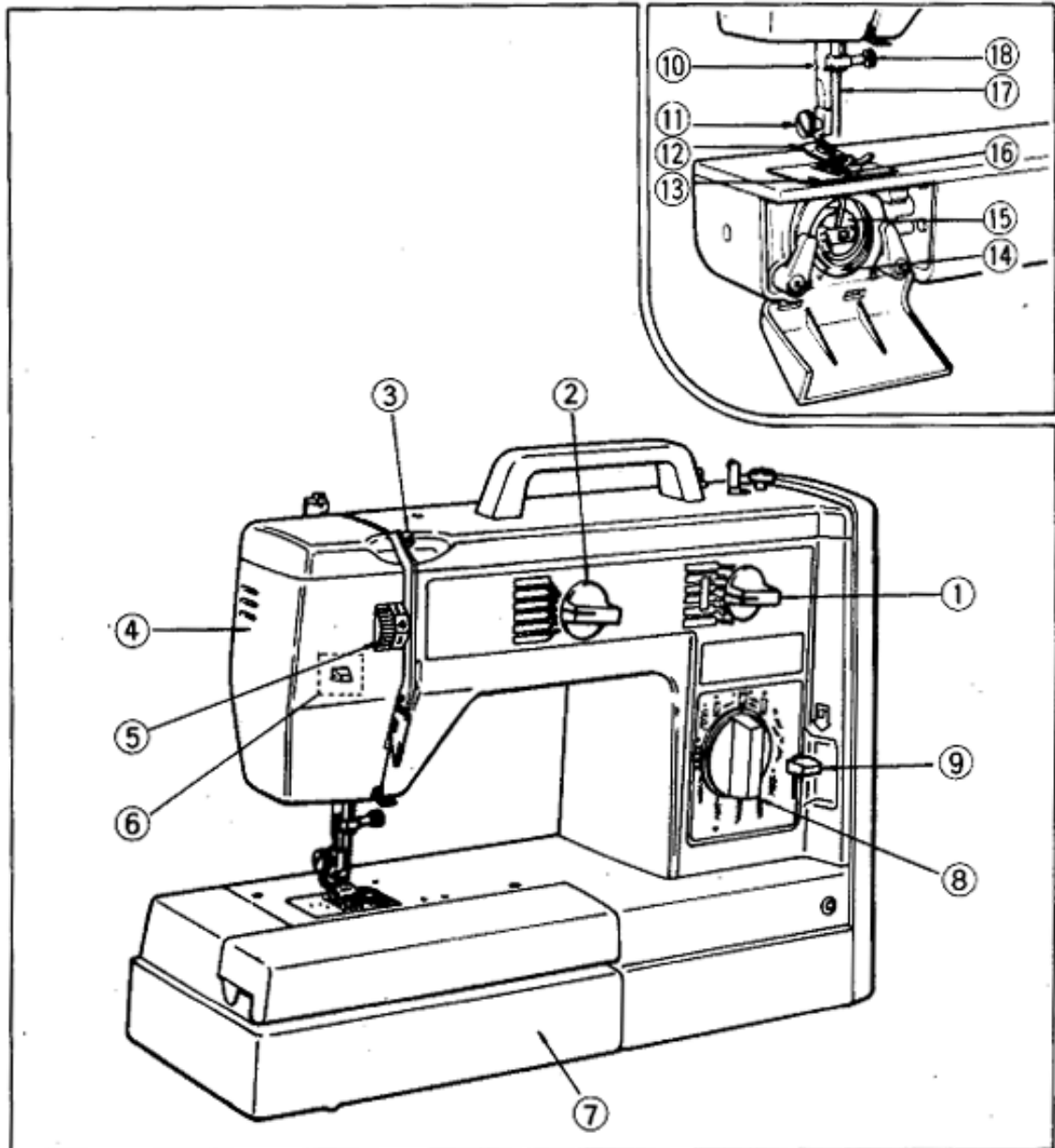

- | | |
|------------------------------|---------------------------|
| 1. Stitch Length Dial | 10. Thread Cutter |
| 2. Stitch Width Dial | 11. Presser Foot Screw |
| 3. Thread Take-up Lever | 12. Presser Foot (Zigzag) |
| 4. Face Plate | 13. Needle Plate (Zigzag) |
| 5. Upper Thread Tension Dial | 14. Shuttle Hook |
| 6. Pressure Adjuster | 15. Bobbin Case |
| 7. Extension Table | 16. Feed Dog |
| 8. Pattern Dial | 17. Needle |
| 9. Reverse Sewing Lever | 18. Needle Clamp Screw |

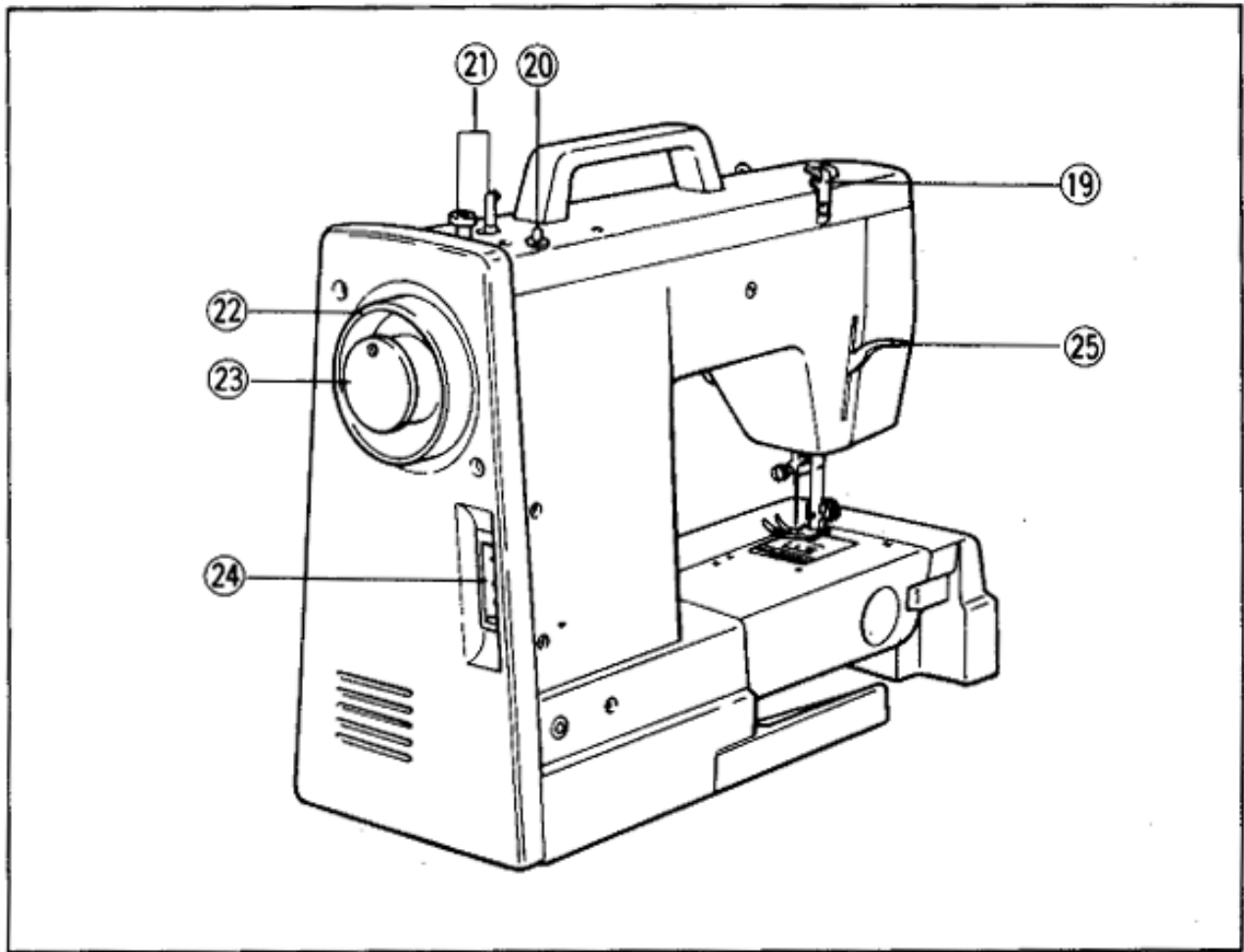

- | | |
|---|-------------------------|
| 19. Thread Guide and Bobbin Winder Disc | 23. Stop Motion Knob |
| 20. Spool Pin | 24. 3-prong Socket |
| 21. Bobbin Winder Device | 25. Presser Foot Lifter |
| 22. Balance Wheel | |

Machine Cover

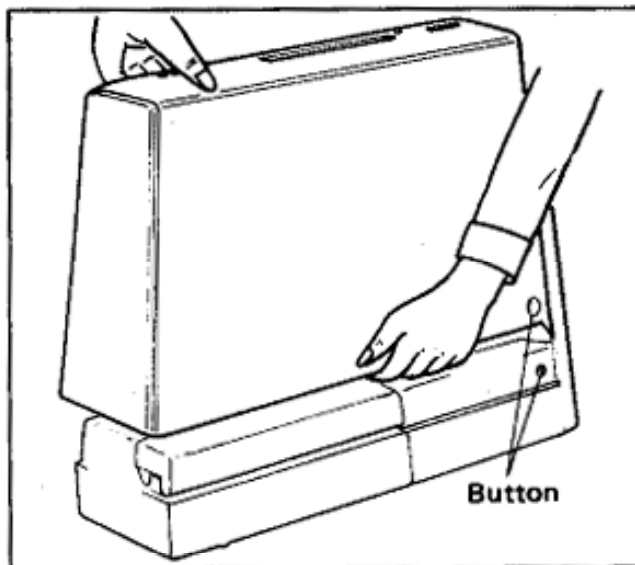

TO REMOVE THE MACHINE COVER FROM SEWING MACHINE

1. Snap open buttons on the front and rear of machine cover.
2. Lift the machine cover gently by hands.

TO REPLACE THE MACHINE COVER

1. Lower the presser foot.
2. Press the spool pin into the machine.
3. Place the foot controller on the machine bed.
4. Push the machine cover down gently.
5. Snap down the machine cover.

Accessories

The following accessories are provided with your sewing machine and they are contained in the extension table. They are designed to help you do many kinds of sewing easily and perfectly. For more details, see each page listed.

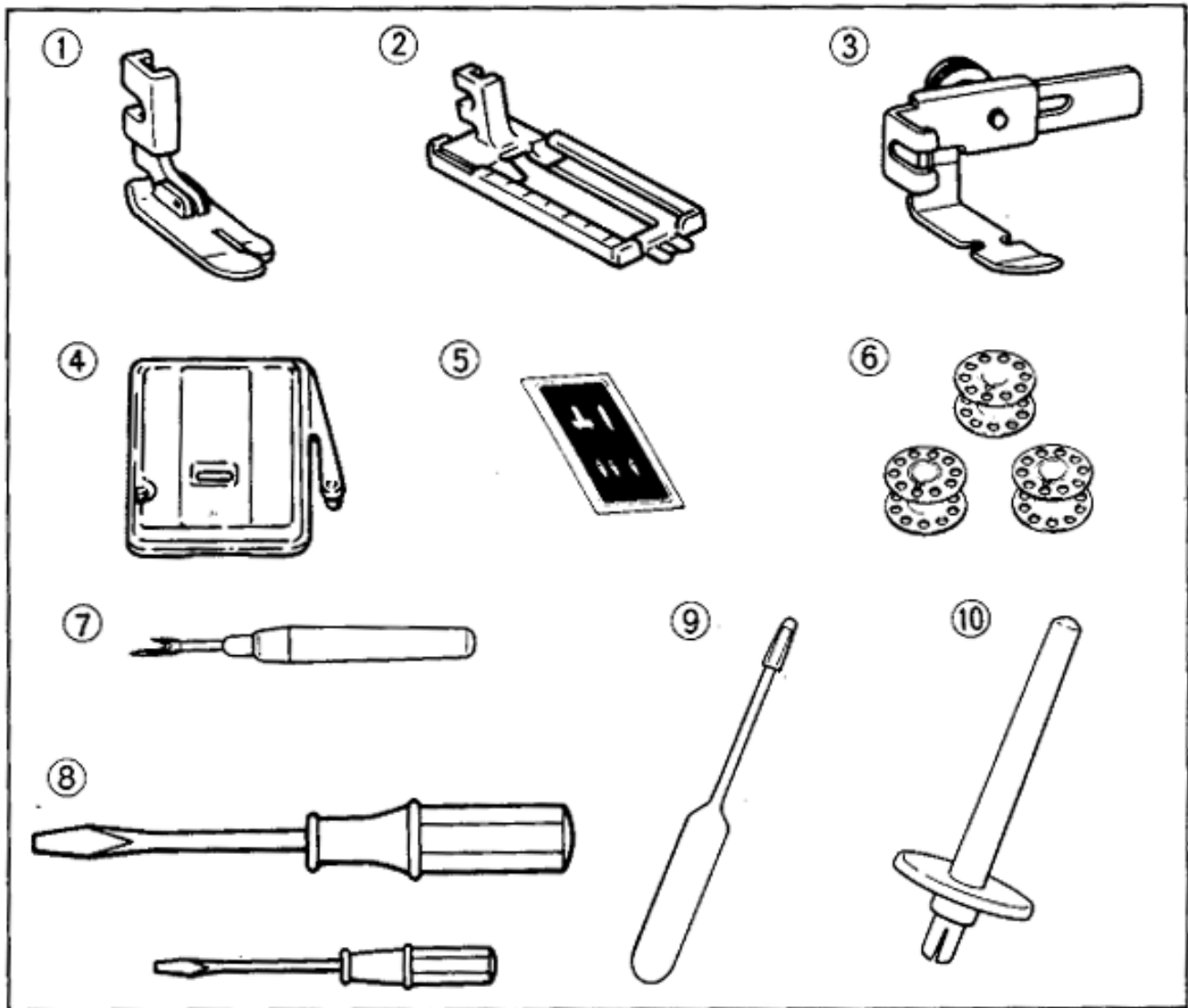

		See page
1.	Straight Stitch Foot	1 pce. 17
2.	Buttonhole & Button Sewing Foot	1 pce. 26
3.	Zipper Foot	1 pce. 29
4.	Darning Plate	1 pce. 31
5.	Needle Pack	
	(Regular Single Needle No. 14.....	3 pcs.) 8
	(Twin Needle.....	1 pce.)
6.	Bobbins	3 pcs. 13
7.	Seam Ripper	1 pce. 27
8.	Screw Driver (Large & Small)	2 pcs.
9.	Oiler	1 pce. 34
10.	Extra Spool Pin	1 pce. 9

The above illustrated accessories are provided with this machine.

Operating Your Sewing Machine

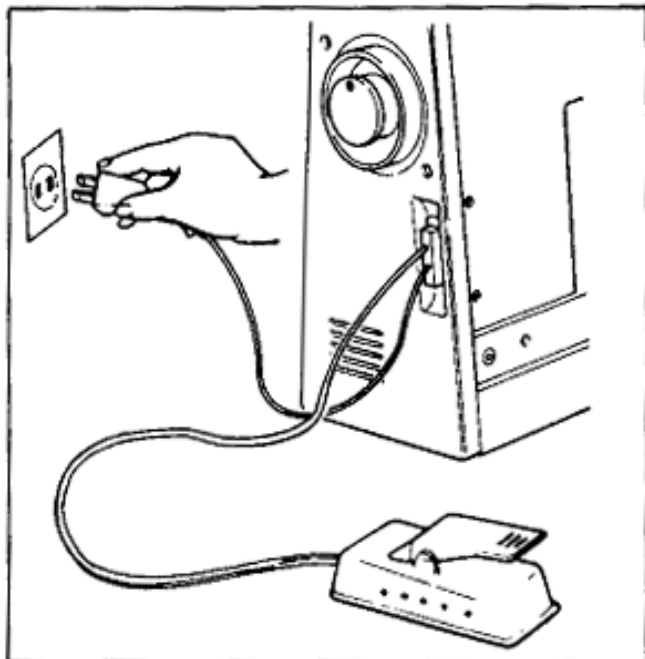

CONNECTING PLUGS

1. First connect the three-prong plug into the machine.
2. Then connect the electric supply plug into a wall outlet.

Caution

When changing needle, bobbin or light bulb, or when sewing machine is not in use, it is recommended that electrical supply plug is disconnected to avoid electrical hazards.

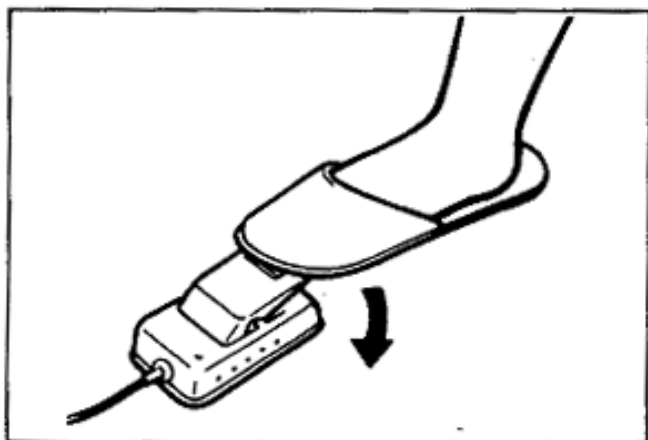

CONTROLLING SEWING SPEED

Place foot on foot control as shown in illustration.

When foot control is pushed down lightly, machine will run at a low speed.

When pressure on foot control is increased, machine will pick up speed.

When foot control is released, machine will stop.

NOTE:

1. Care should be taken that nothing is placed on foot controller when machine is not in use.
2. A new sewing machine or one that has not been in use for a long period of time should be oiled as per instruction on pages 34 & 35. After oiling be sure to wipe up any excess oil.

Various Controls

PATTERN DIAL

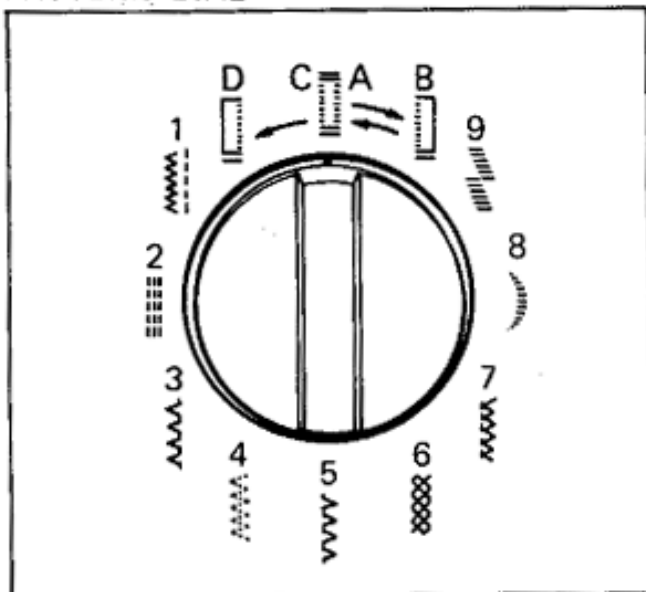

Your built-in pattern sewing machine enables you to obtain perfect buttonholes and various utility stitches, such as triple stretch stitch, elastic stitch, etc., by simply selecting the pattern on this dial.

1. Raise needle to its highest position.
2. Simply turn the dial and set the pattern you desire at the setting point.

NUMBERS AND STITCH OF PATTERN

1. General Zigzag Stitch and Straight Stitch.
 2. Triple Stretch Stitch.
 3. Blind Stitch.
 4. Elastic Stitch.
 5. Shell Stitch.
 6. Link Stitch.
 7. Elastic Overlock Stitch.
 8. Scallop Stitch.
 9. Lightning Stitch.
- A-B-C-D. Automatic Buttonhole.

STITCH LENGTH DIAL

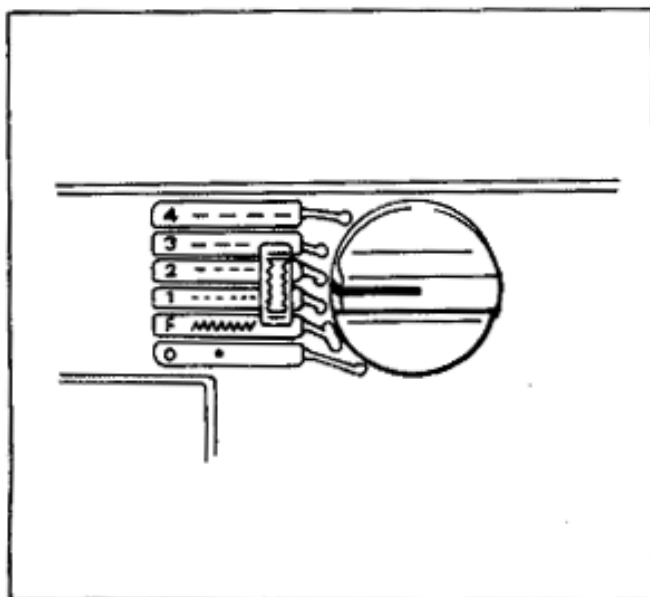

The stitch length is regulated by turning the stitch length dial.

Numerals beside the dial represent the stitch length. THE HIGHER THE NUMBER, THE LONGER THE STITCH.

The "0" means that the material is not fed.

The "F" area is used for making a SATIN STITCH (a close zigzag stitch) and this stitch is used for making decorative patterns.

The dial position needed to obtain the satin stitch is varied according to the material and thread being used. To determine exact dial position, you must observe the feeding of the material.

STITCH WIDTH DIAL

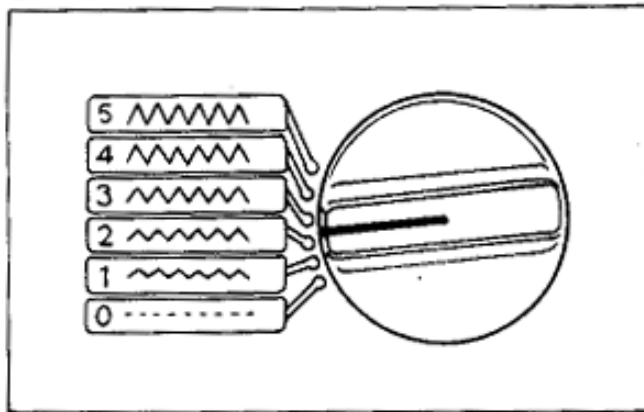

The zigzag width is regulated by operating the stitch width dial.

Numerals beside the dial represent the width of stitch. THE HIGHER THE NUMBER, THE WIDER THE STITCH.

The "0" means straight stitch only.

- NOTE:
1. Do not move the dial while the needle is in the material.
 2. When using twin needle, dial should always be set at under "3".

REVERSE SEWING LEVER

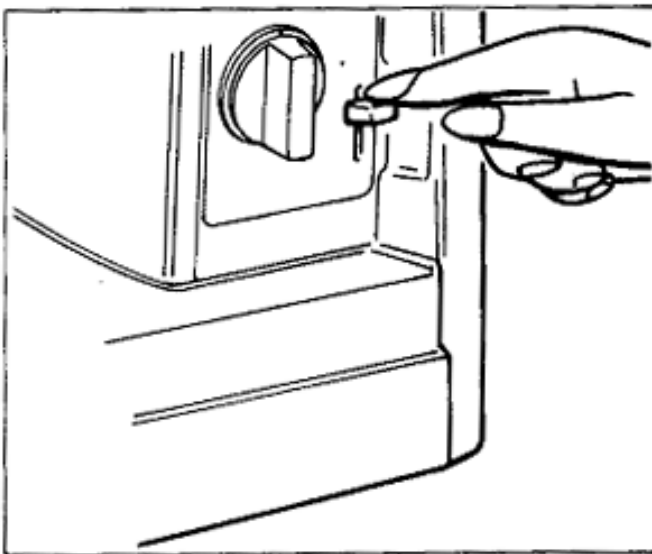

To sew in reverse, depress sewing lever downward as far as it will allow. Hold lever in this position until you wish to sew forward. When lever is released it will spring back in position and you will sew in forward direction.

Reverse sewing is used for back-tacking and reinforcement.

PRESSURE ADJUSTER

Upon opening face plate, you will find pressure adjuster which controls the pressure of presser bar.

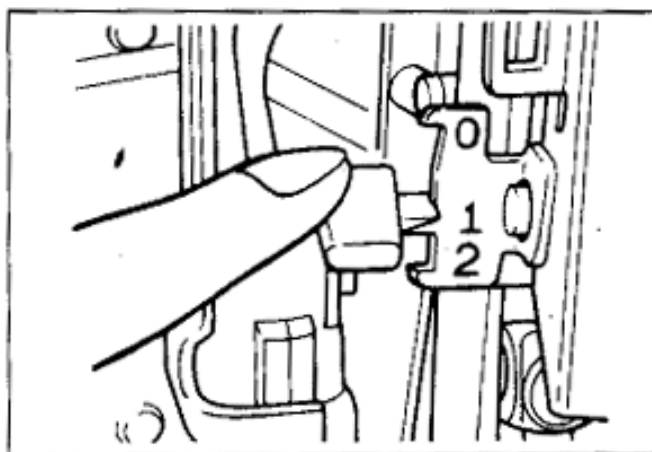

In accordance with sewing material select the desired pressure.

HOW TO MANIPULATE

Pull the knob slightly toward left and shift the lever up or down to your desired position.

0 Darning, Mending, Embroidering

1 Lighter and medium materials.

2 Thick and heavy materials.

NOTE: When pressure is set at "0" for darning, mending etc., also place darning plate on needle plate. (See instruction page 31)

Presser Foot

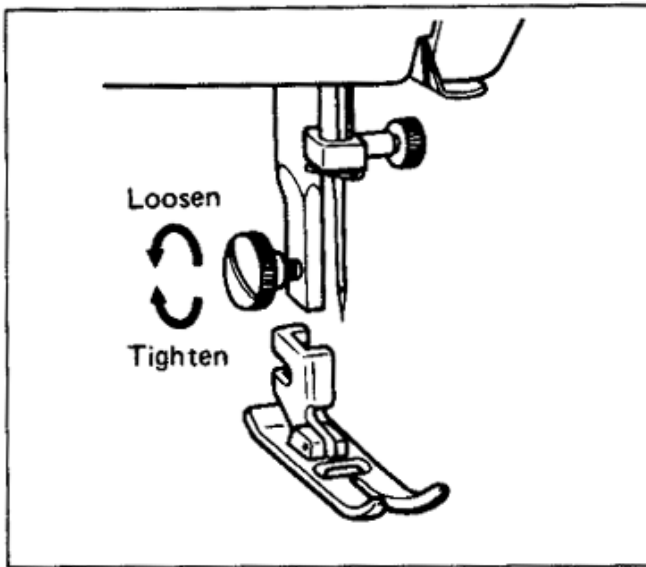

You will find various kinds of presser feet for special use in the extension table.

According to your sewing needs, it may be necessary to change presser foot.

TO CHANGE THE PRESSER FOOT

1. Raise needle to its highest position.
2. Raise presser foot.
3. Loosen presser foot thumb screw and remove presser foot.
4. Place grooved side of the new presser foot against the flat of the presser bar.
5. Tighten thumb screw.

Needle

HOW TO CHANGE THE NEEDLE

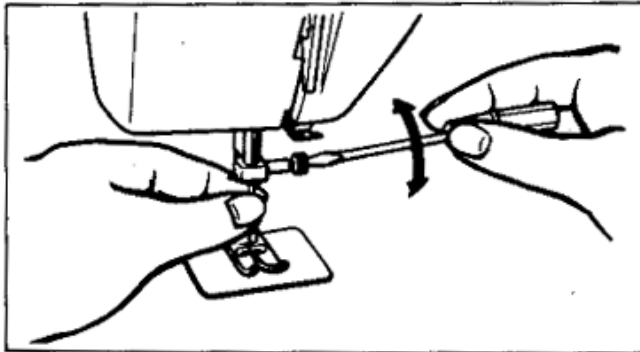

1. Raise needle to its highest position.
2. Loosen needle clamp screw and remove old needle.
3. Insert new needle up into needle clamp hole as far as it will go against the needle stop. Make sure the flat side of the needle faces toward the back and the long groove toward you.
4. Tighten needle clamp screw securely.

HOW TO CHECK THE NEEDLE

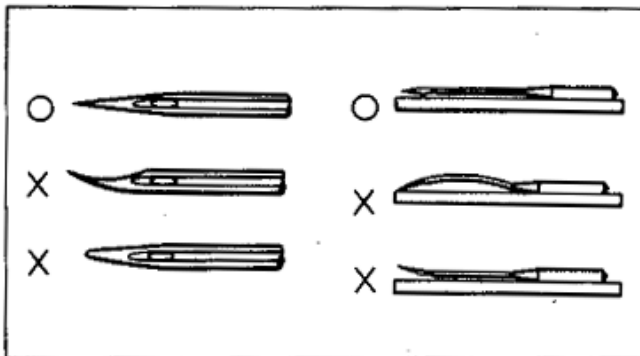

1. The sewing needle must always be straight and sharp for smooth sewing.
2. To check if needle is bent, place flat side of needle down as shown in illustration at left.

Twin Needle

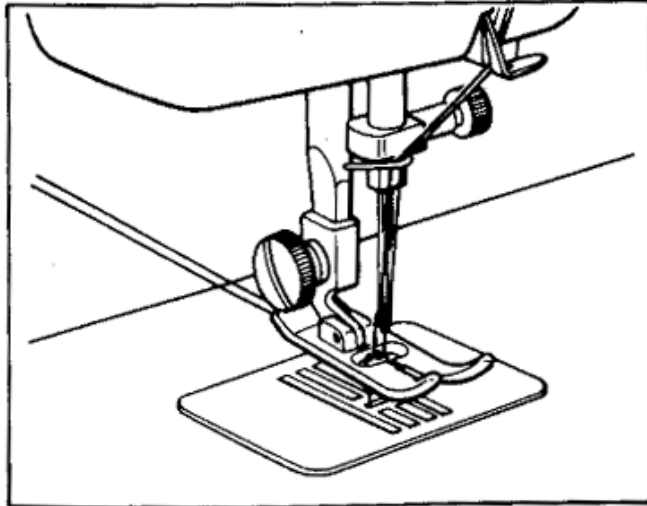

Your sewing machine is specially constructed for optional twin needle sewing by setting extra spool pin into hole on the top of machine. You can use either one or two colors of upper thread.

Make sure that two threads used to thread twin needle are of the same weight. If thread is not of the same weight, stitching will be faulty.

INSERTING TWIN NEEDLE

Insert in same manner as single needle. Flat side of needle should face toward back and long groove should face you.

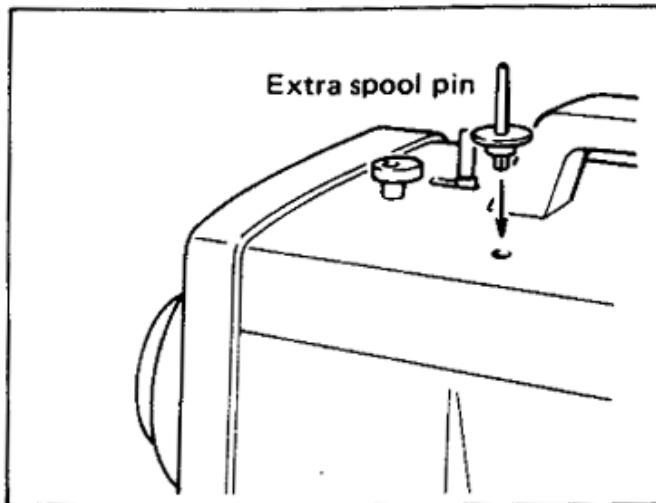

THREADING TWIN NEEDLE

Follow instructions for single needle threading (see page 11), but thread each needle separately.

NOTE FOR TWIN NEEDLE SEWING

1. Use ZIGZAG PRESSER FOOT.
2. Use stitch width dial at under "3".

Relative Chart of Sewing Material, Needle and Thread

SEWING MATERIALS		NEEDLE SIZES	THREAD SIZES
VERY THIN	Fine tricot, Fine lace, Thin linen, Silk, Tulle, Chiffon	9	Cotton: 80-120 Synthetic Fine Mercerized Cotton
LIGHTWEIGHT	Organdy, Jersey, Voile, Taffeta, Synthetics; Silk, Batiste	11	Cotton: 60-80 Silk: "A" Synthetic Mercerized 50
MEDIUM	Cotton, Gingham, Poplin, Percale, Pique, Satin, Velvet, Lightweightwool, Fine corduroy, Suitings	14	Cotton: 50-60 Silk: "A" Synthetic Mercerized 50-60
HEAVY	Denim, Gabardine, Tweed, Corduroy	16	Cotton: 40-50 Mercerized Heavy Duty
VERY HEAVY	Canvas, Overcoating, Upholstery	18	Cotton: 30-40 Mercerized Heavy Duty

- NOTE: 1. Select correct size of needle and thread from above chart.
2. Use the same size thread for upper and lower threads.

Sew-Light

SEW-LIGHT SWITCH KNOB (BUTTON)

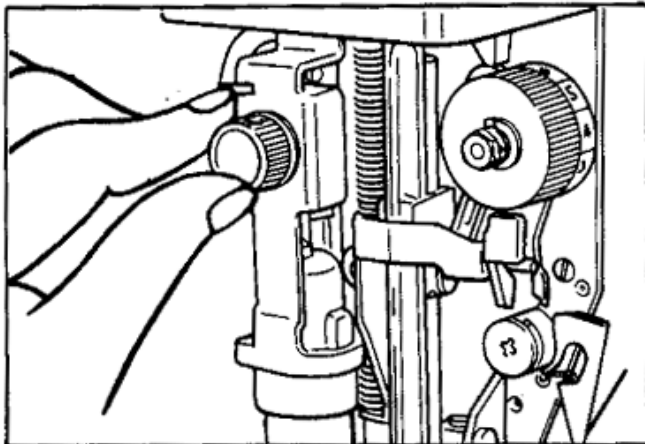

Swing open face plate.

Turn this knob in any direction to switch light on and off. (110/115V AREA)

Push this button to switch light on and off. (220/240V AREA)

HOW TO CHANGE THE BULB

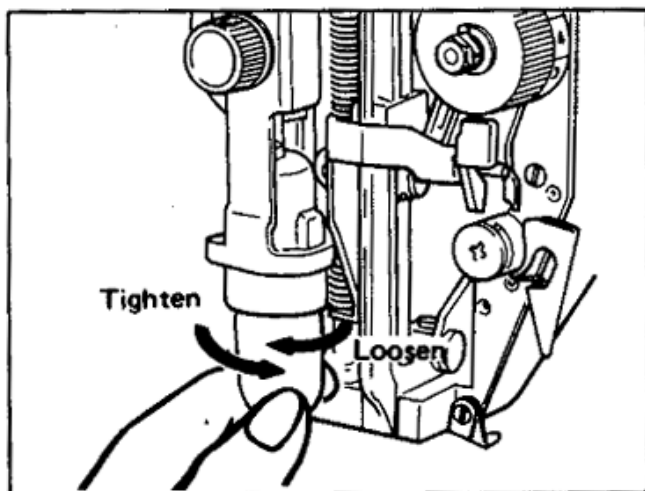

1. Swing open face plate.
2. Remove bulb by turning counter-clockwise.
3. Replace bulb and swing face plate to close.

NOTE: 1) Disconnect electric plug from wall outlet before removing bulb.

2) Always use CORRECT SPARE BULB.

MAXIMUM INPUT OF LAMP
12W 110/115V AREA
15W 220/240V AREA

Extension Table

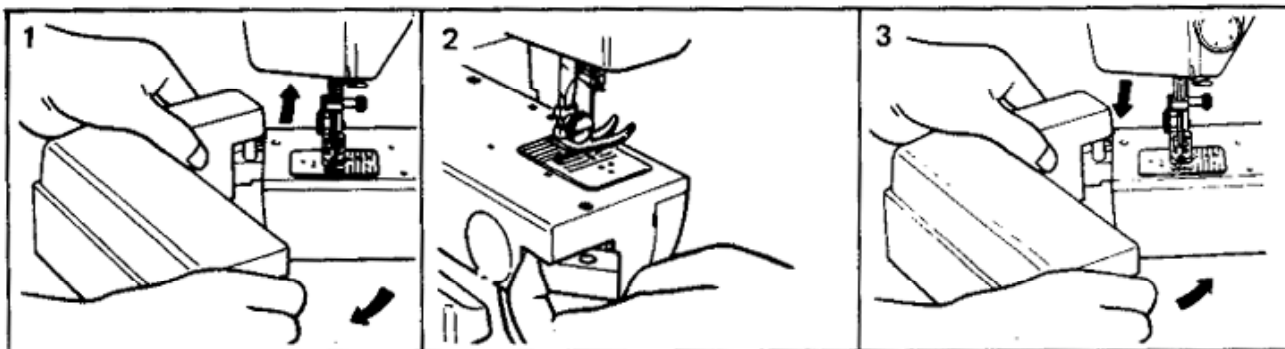

Your sewing machine has an extension table and by moving it, your sewing machine can convert into either a flat bed machine or free arm machine.

1. Move extension table toward you and lift it. Your sewing machine becomes a free arm machine.
2. First push the hinge out of machine bed by finger and insert the shaft of extension table into the hole of hinge.
3. Then move it toward free arm bed. Your sewing machine becomes a flat bed machine.

Upper (Needle) Thread

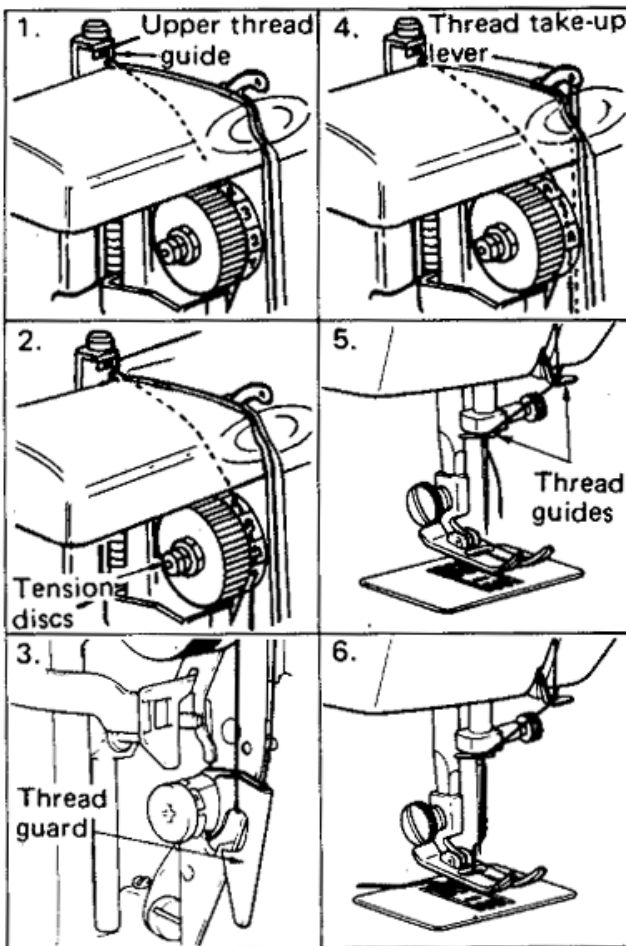
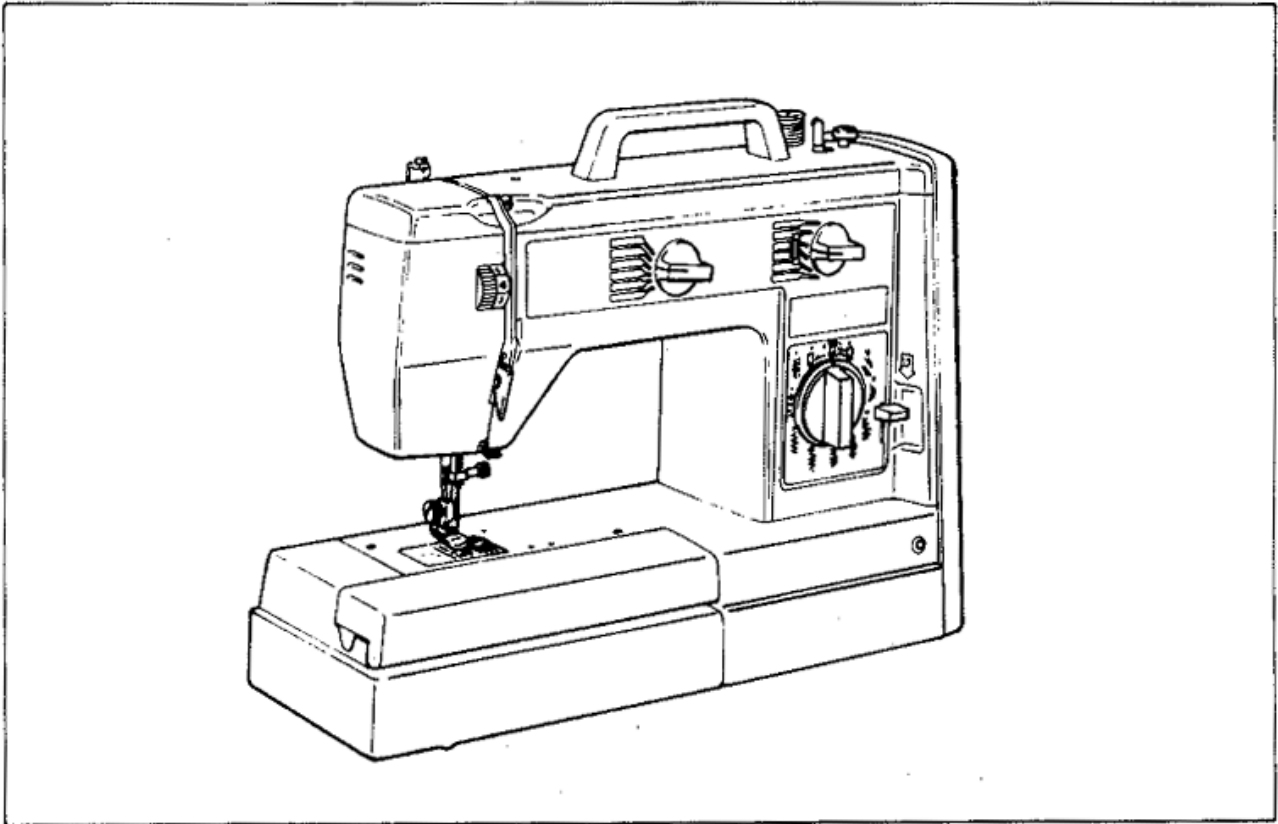

Before threading, raise presser foot and take-up lever to the highest position.

Then place spool of thread on the spool pin.

1. Pass thread through the eye of upper thread guide.
2. Pass thread between upper thread tension discs.
3. Bring thread down and up through thread guard from left to right so that thread picks up the thread check spring.
4. Pass thread into the eyelet of the thread take-up lever from left to right.
5. Bring down again and pass thread through the thread guides.
6. Thread needle from front to back and draw the thread out about 2 inches (5 cm).

NOTE:
IF THE THREADING ORDER IS NOT CORRECT, THREAD BREAKAGE, STITCH SKIPPING, WRINKLING OF FABRIC WILL OCCUR.

Lower (Bobbin) Thread

HOW TO WIND BOBBIN

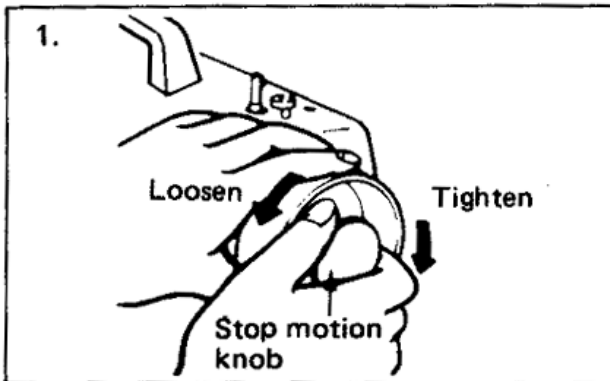
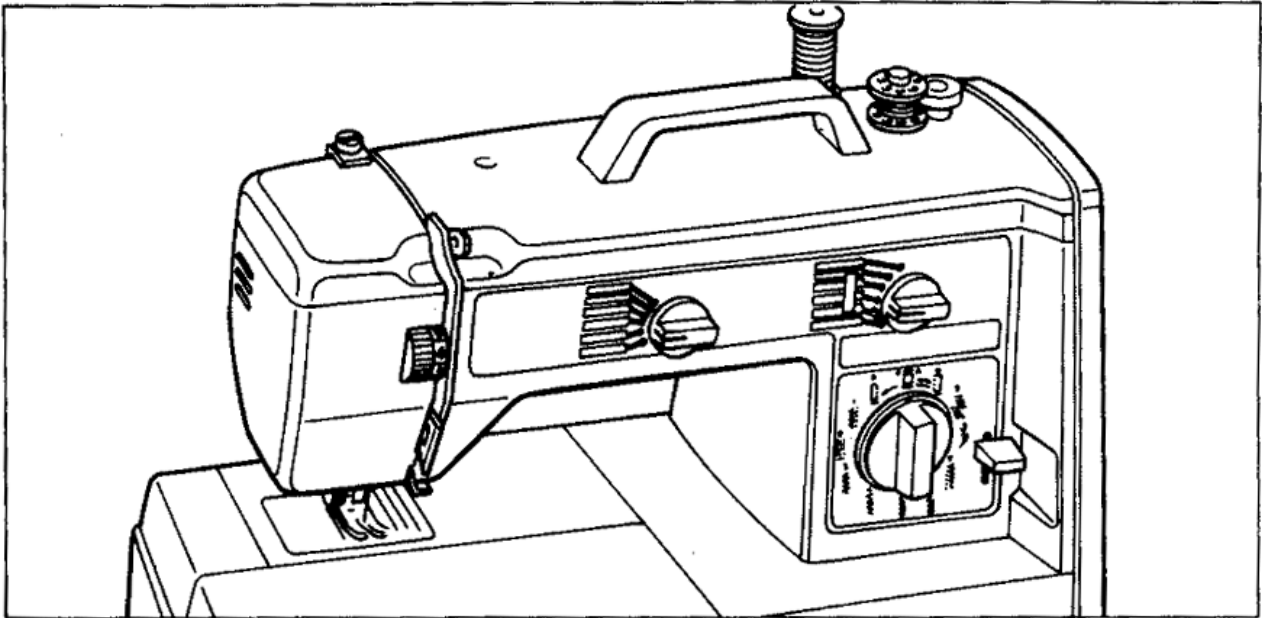

1. Loosen stop motion knob by turning it toward you.

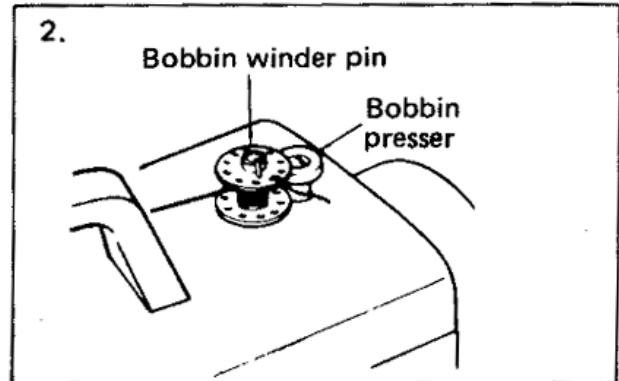

2. Place an empty bobbin on the bobbin winder pin.

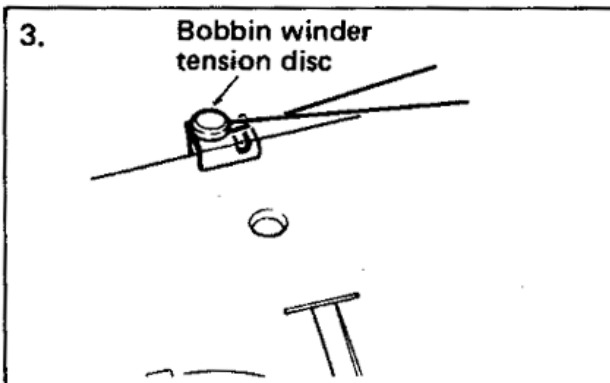

3. Place thread spool on the spool pin and take thread through bobbin winder tension disc.

4. Wind the thread a few times around the bobbin clockwise and push the bobbin toward bobbin presser. Start the machine gently.

5. Bobbin stops winding when full.

6. Push the bobbin to the left and remove it. Tighten stop motion knob securely.

HOW TO REMOVE AND INSERT BOBBIN CASE

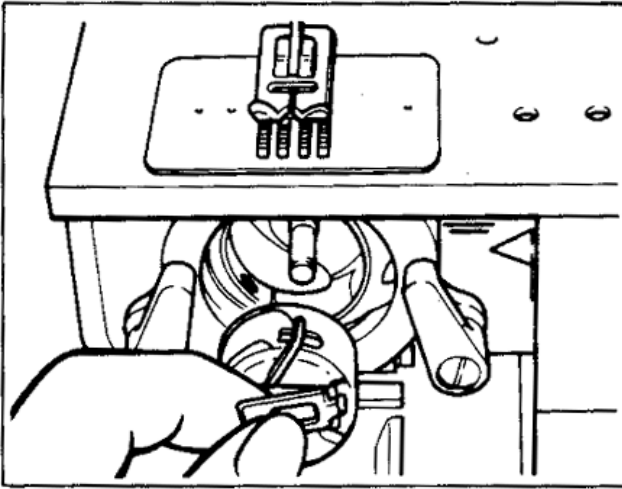

TO REMOVE BOBBIN CASE

1. Raise needle to its highest position.
2. Open the shuttle cover by turning it down.
3. Pull and open the latch of bobbin case.
4. Pull out bobbin case from the shuttle.

TO INSERT BOBBIN CASE

1. Raise needle to its highest position.
2. Holding bobbin case latch with metal finger of case pointing up, fit it into the notch at the top of shuttle race.
3. Push case back fully making sure the case is in the proper position and release the latch.

NOTE:

- (A) Four inches (10 cm) of thread should be drawn out and left out of case.
- (B) Latch of bobbin case should be open fully to prevent bobbin coming out of case.
- (C) If bobbin case is not placed back in machine properly it will come out from the shuttle immediately after starting to sew.

HOW TO THREAD BOBBIN CASE

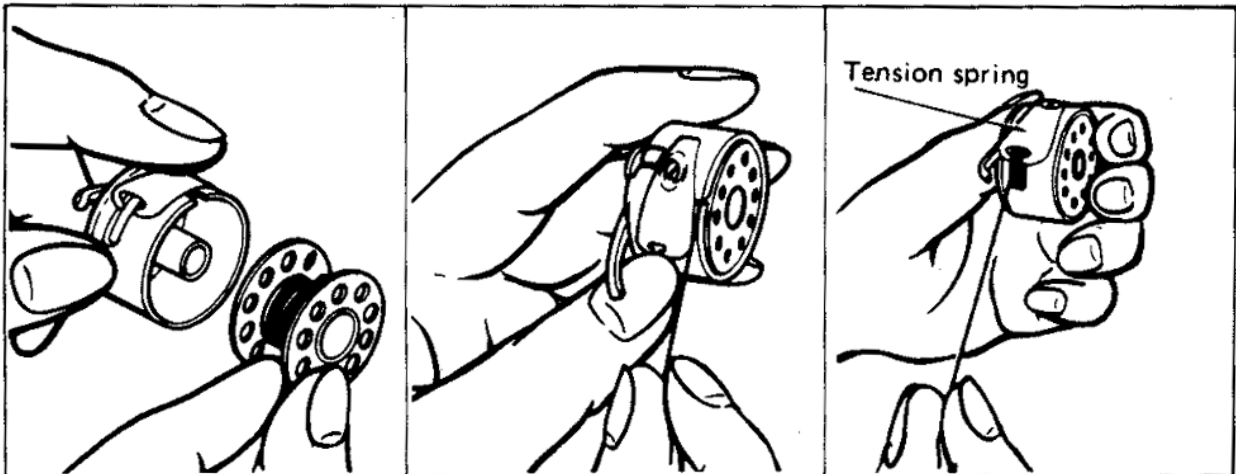

1. Unwind about 4 inches (10 cm) of thread from the bobbin. Insert wound bobbin into bobbin case.
2. Pull trailing thread into the slot of case.
3. Pull thread to the left under tension spring until thread enters into delivery eye.

HOW TO PULL UP LOWER THREAD

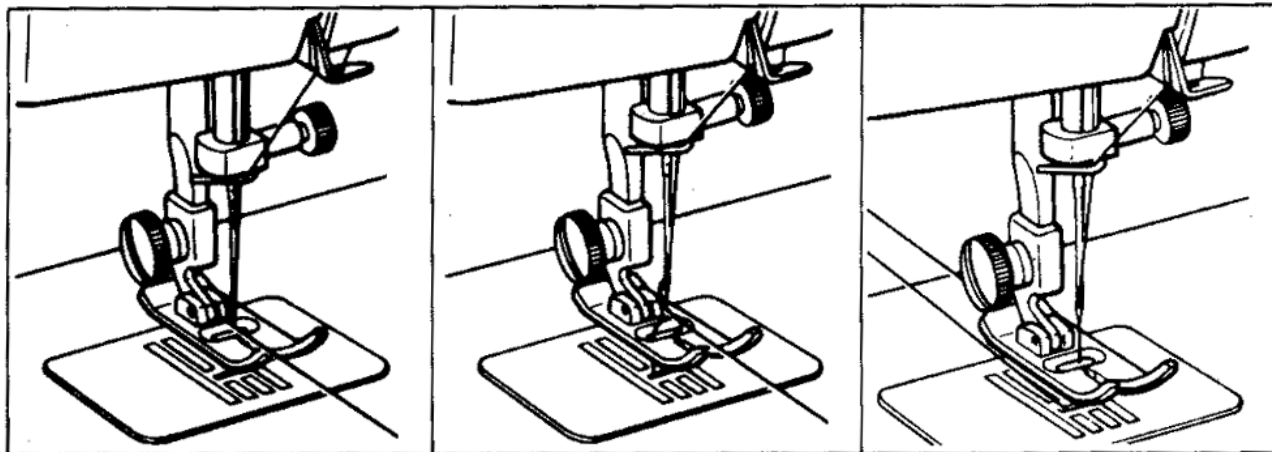

1. Raise needle and presser foot to the highest position. With left hand, hold the end of upper thread and with right hand, turn balance wheel toward you until the needle moves down and up again to its highest position.

2. Now upper thread catches the lower thread in a loop. Pull thread toward you so that lower thread will come up in a large loop from the presser foot.

3. Pull both threads under the toes of presser foot and place them to the rear leaving about 4 inches (10 cm).

Thread Tension

It is important that tension of upper and lower threads be equal to prevent puckering of material or other problems.

It is recommended that a test sample be made before starting to sew.

UPPER THREAD TENSION

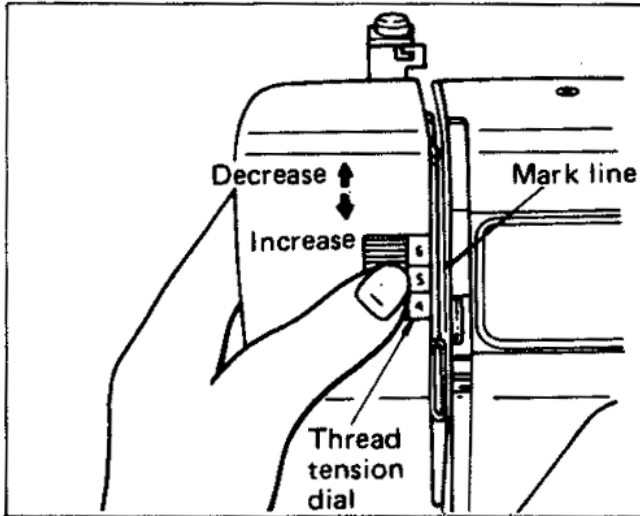

To regulate thread tension, merely turn thread tension dial with left thumb after lowering the presser foot.

THE HIGHER THE NUMBER, THE TIGHTER THE TENSION.

To increase tension: Turn dial downward to large number.

To decrease tension: Turn dial upward to smaller number.

NOTE: The zigzag stitch requires less upper thread tension than straight stitch.

LOWER THREAD TENSION

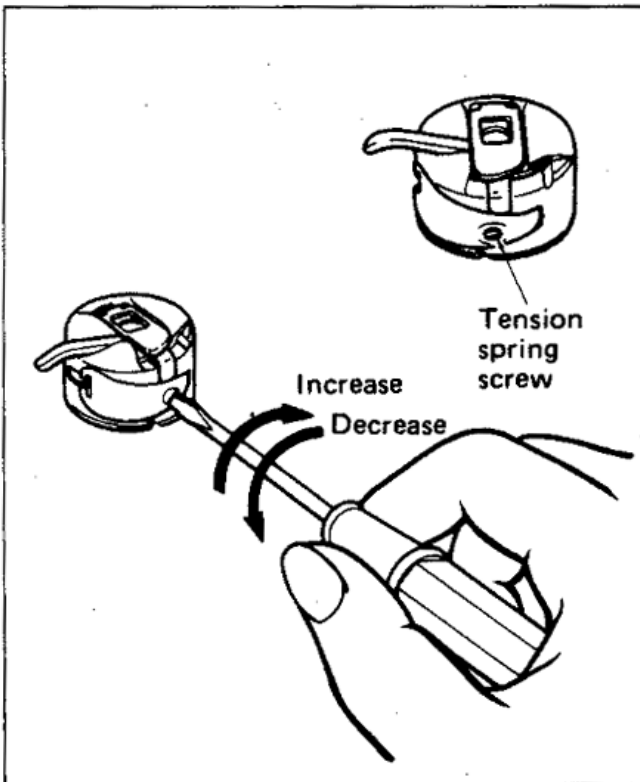

Although lower thread tension has already been adjusted at the factory, when sewing very thin or heavy material it may have to be readjusted.

To regulate the lower thread tension, turn small screw on the tension spring of the bobbin case with the small screw driver.

To increase tension: Turn the small screw clockwise very slightly.

To decrease tension: Turn the screw counter-clockwise very slightly.

PERFECT STITCHING

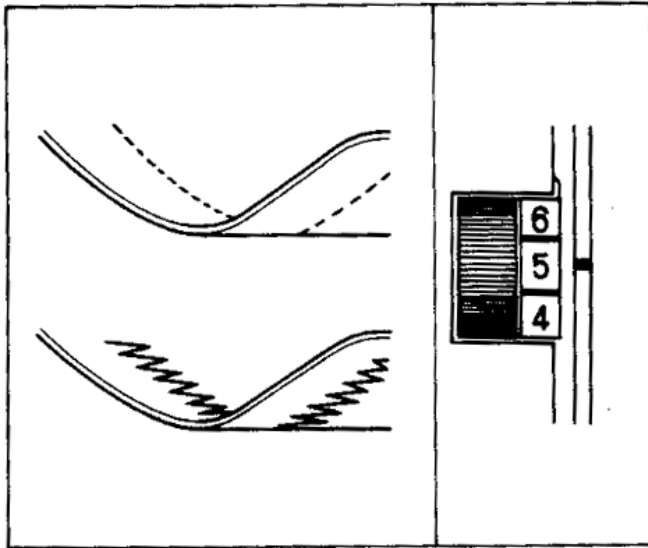

Tension of upper and lower threads should be equal, just sufficiently strong to lock both threads in material.

Perfect stitching appears flat with no puckering of material.

INCORRECT STITCH (A)

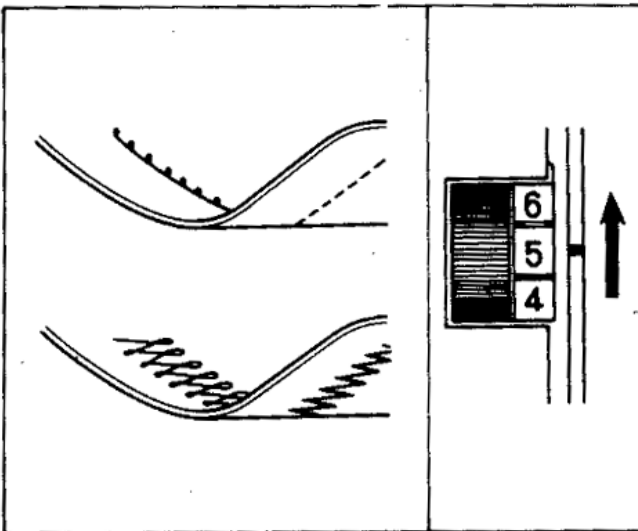

The upper thread lies on the surface of the material by pulling the lower thread up as shown.

This is caused by tight tension on the upper thread or loose tension on the lower thread.

To correct this, turn the upper thread tension dial to a lower number.

When perfect stitch cannot be obtained by only upper thread tension dial, adjust the bobbin tension accordingly.

INCORRECT STITCH (B)

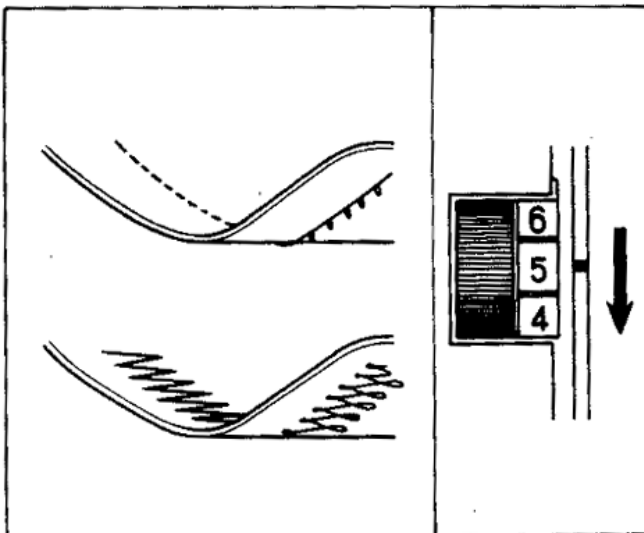

The lower thread lies on the under surface of the material by pulling upper thread down as shown.

This is caused by loose tension on the upper thread or tight tension on the lower thread.

To correct this, turn the upper thread tension dial to a higher number.

If perfect stitching cannot be obtained by changing upper thread tension, adjust the bobbin tension.

NOTE: It is recommended that test samples be made before starting to sew.

2

Straight Stitching

PATTERN DIAL	:	1
STITCH LENGTH DIAL	:	1 ~ 4
STITCH WIDTH DIAL	:	0
PRESSER FOOT	:	Straight or Zigzag
NEEDLE	:	Single
PRESSURE ADJUSTER	:	1 or 2

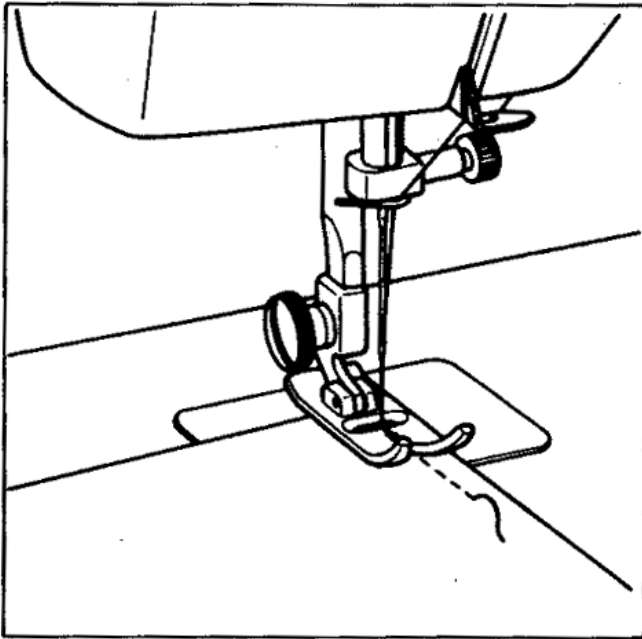

NOTE: Use straight stitch foot when sewing light or elastic type materials with straight stitch.

HOW TO START SEWING

1. Raise needle to its highest position and lift presser foot.
2. Place material under presser foot and position needle 3/8 inch (10 mm) from material edge.
3. Lower presser foot.
4. Pull up lower thread by turning the balance wheel toward you and place both upper and lower thread to the left.
5. For reverse sewing depress Reverse Sewing Lever as far as it will allow. Reverse sewing is used where reinforcement is needed.
6. Release Reverse Sewing Lever and start sewing in forward direction.

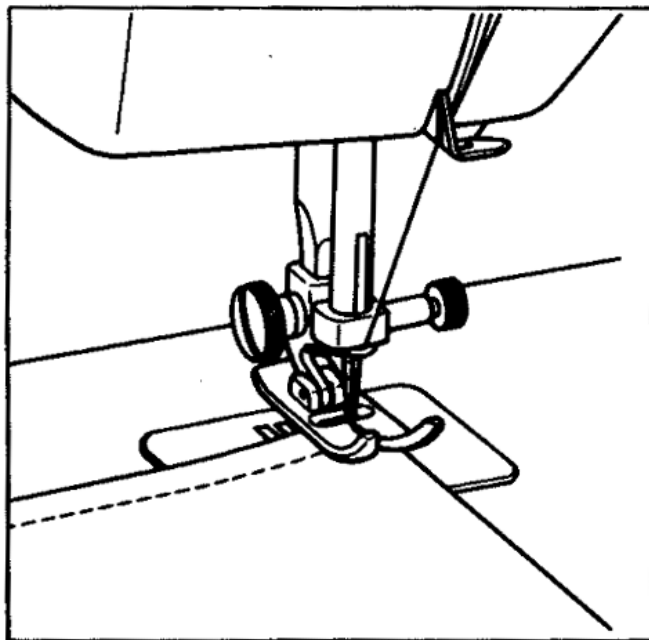

HOW TO CHANGE SEWING DIRECTION

1. Stop machine at the turning point while the needle is in the material.
2. Raise the presser foot and turn the material to the new direction* while the needle acts as the axis.
3. Lower the presser foot and start sewing in new direction.

NOTE: In case of twin needle sewing, raise the needle at the turning point.

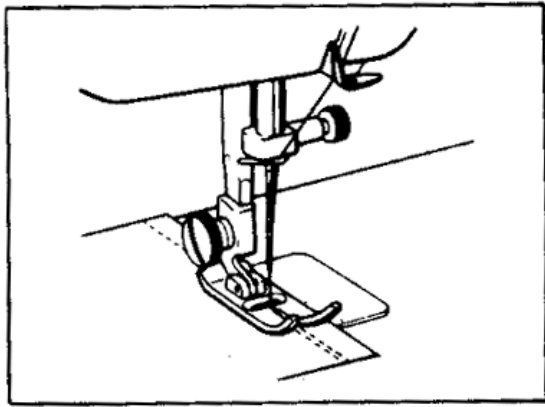

HOW TO FINISH YOUR SEWING PROJECT (REVERSE STITCHING)

Reverse stitching is used to reinforce stitches near the edge of material or wherever reinforcement is needed.

1. This is done by stitching to the edge of material ... then stopping.
2. Depress Reverse Sewing Lever in direction of arrow and stitch backwards for 3/8 inch (1 cm) from material edge.

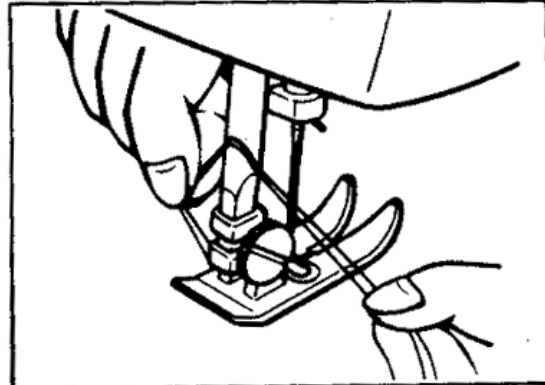

HOW TO REMOVE FINAL SEWING FROM MACHINE

1. Stop the machine.
2. Raise needle to its highest position and make sure that the thread take-up lever is also to its highest position.
3. Lift presser foot and pull out the material gently to the left side diagonally.
4. Cut both threads on the thread cutter.
5. Leave about 4 inches (10 cm) of threads between toes of the presser foot to the rear while the thread take-up lever is at the highest position, and you are ready to sew again without any chance of thread pulling out of the needle.

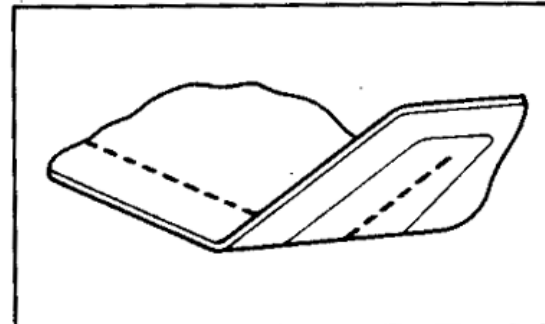

HOW TO SEW VERY THIN MATERIAL

An underlay of thin paper will help to eliminate skipped stitches and puckering on very thin material.

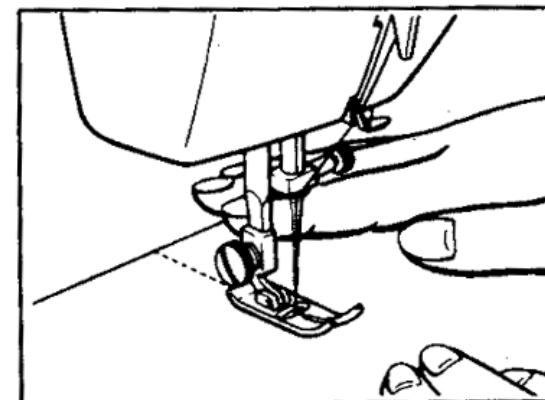

HOW TO GUIDE YOUR MATERIAL

Do not pull the material. Let the machine do the work. Merely guide the material with your fingers in front of the presser foot as shown in the illustration.

If you pull the material, your needle might either bend or break.

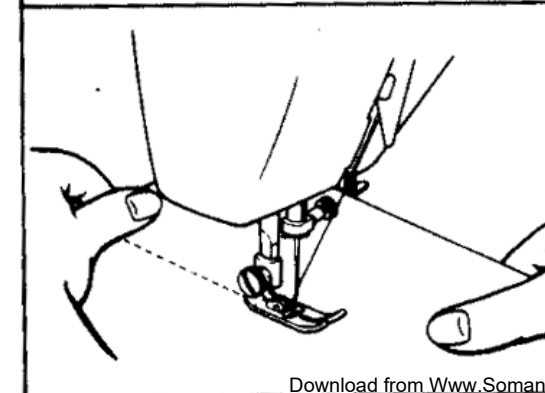

However, in the case of special materials, such as tricot, crepes, knits, etc., we recommend that you support the material both in front and back of the presser foot with gentle tension as shown in the illustration on the left side.

3

Zigzag Stitching

PATTERN DIAL	:	1
STITCH LENGTH DIAL	:	1~4(For SATIN STITCH dial is set at F)
STITCH WIDTH DIAL	:	1~5(Twin Needle sewing, always set at 3)
PRESSER FOOT	:	Zigzag
NEEDLE	:	Single or Twin Needle
PRESSURE ADJUSTER	:	1 or 2

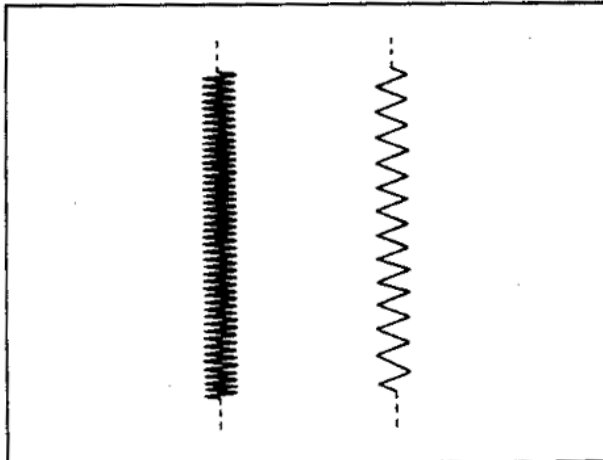
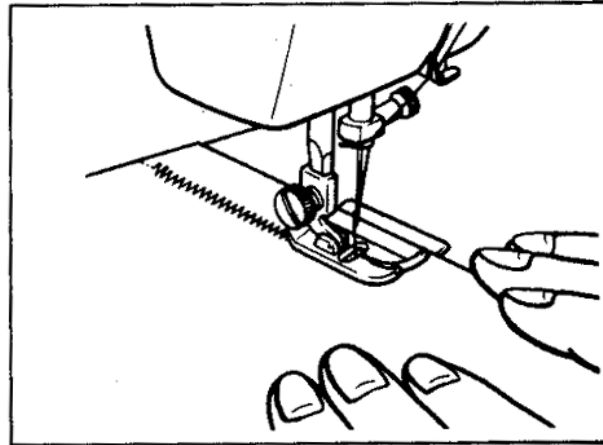
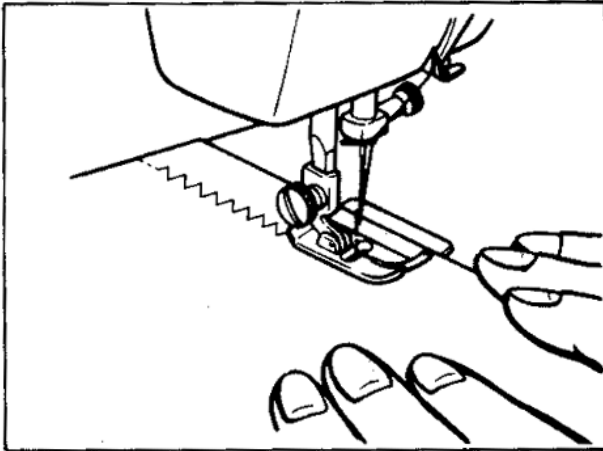

SIMPLE ZIGZAG STITCH

Set Stitch Length Dial between 1-4 for simple zigzag stitch.

1. With Stitch Length Dial to between 0-1 sew 5-6 straight stitches for reinforcement.
2. Set Stitch Width Dial to your desired width and commence sewing.
3. Reset Stitch Width Dial to "0" and set Stitch Length Dial to between 0-1 to again reinforce stitches before removing work from machine.

NOTE: Zigzag stitching requires less upper thread tension than straight stitching.

SATIN STITCH

When Stitch Length Dial is set between 0-1 produces the "SATIN STITCH" which is used for making fine buttonholes or decorative stitches.

NOTE: It is recommended that a test sample be made before starting to sew.

4

Decorative Stitches

- PATTERN DIAL : 1
- STITCH LENGTH DIAL : For SATIN STITCH set dial at F
- STITCH WIDTH DIAL : See Instructions Below
- PRESSER FOOT : Zigzag
- NEEDLE : Single or Twin Needle
- PRESSURE ADJUSTER : 1 or 2

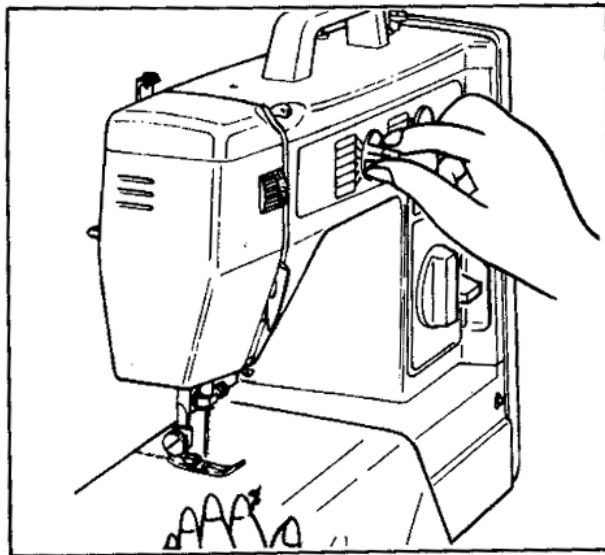

By using the "SATIN STITCH" as in the following instructions various decorative stitches can be obtained.

NOTE: Set Stitch Width Dial at under "3" when using twin needle.

Needle	Patterns to be sewn	How to move Stitch Width Dial
Single needle		At even speed from 0 to 5 (3) and from 5 (3) to 0. Repeat this.
Twin needle		
Single needle		Almost the same manner as above but make round patterns.
Twin needle		
Single needle		Slowly from 0 to 5 (3) and quickly back to 0. Repeat the movement.
Twin needle		

NOTE: Number in brackets represents twin needle sewing.

Triple Stretch Stitch

PATTERN DIAL	:	2 (Triple Stretch Stitch)
STITCH LENGTH DIAL	:	4
STITCH WIDTH DIAL	:	0
PRESSER FOOT	:	Zigzag or Straight
NEEDLE	:	Single (See Note 1)
PRESSURE ADJUSTER	:	1 or 2

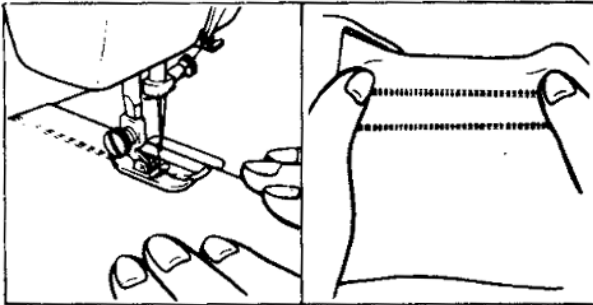

The "Triple Stretch Stitch" is used for any stretch material such as knitted fabric, tricot, etc.

This stitch is three times the strength of a regular stitch and gives elasticity to seams which prevents thread breakage.

NOTE: When sewing extremely light or elastic material use straight stitch presser foot.

Shell Stitch

PATTERN DIAL	:	5 (Shell Stitch)
STITCH LENGTH DIAL	:	4
STITCH WIDTH DIAL	:	5
PRESSER FOOT	:	Zigzag
NEEDLE	:	Single
PRESSURE ADJUSTER	:	1 or 2

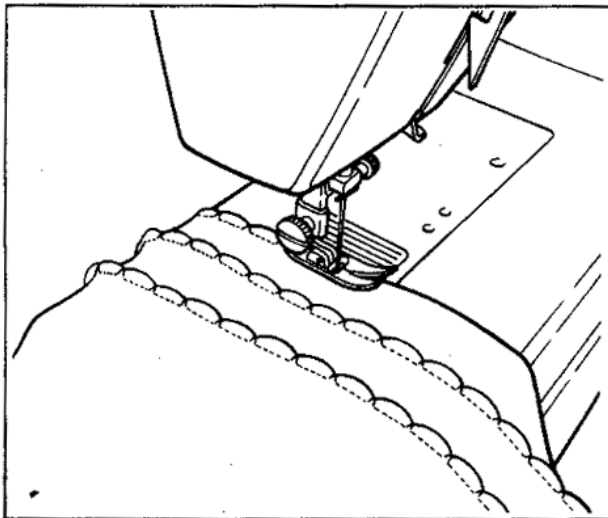

This stitch can be used for sewing a picoted edge on a light material.

1. Sew material on bias, placing material under the presser foot so that straight stitches are sewn on seam line and zigzag stitches are sewn slightly over seam edge.
2. This work requires a little tighter upper thread tension than normal.
3. Sew at slow speed.
4. Edge of material will be picoted.

Blind Stitch

PATTERN DIAL	: 3 (Blind Stitch)
STITCH LENGTH DIAL	: 1 ~ 2
STITCH WIDTH DIAL	: 3 ~ 5
PRESSER FOOT	: Zigzag
NEEDLE	: Single
PRESSURE ADJUSTER	: 1 or 2

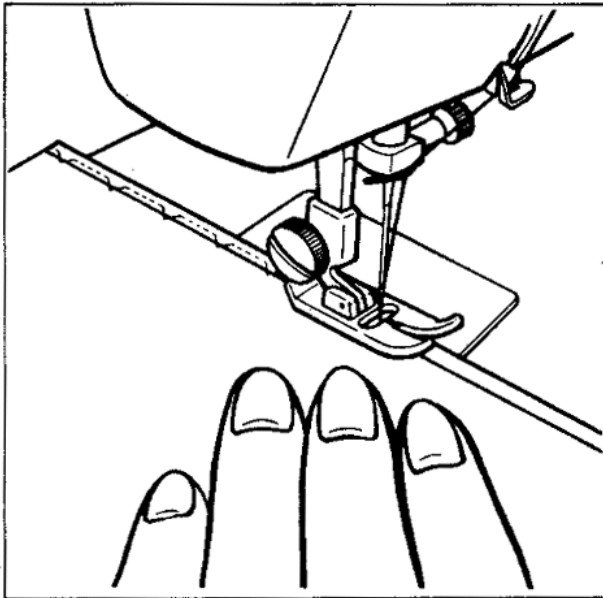

BLIND STITCH

1. Thread used should be the same color as material used.
2. Fold material to size of hem desired and then fold back as shown in Figure A leaving 1/5 inch (5 mm) overlap at edge.
3. Sew on fold as in Figure B.
4. When material is unfolded you will have a blind stitched hem as in Figure C.

Fig. A

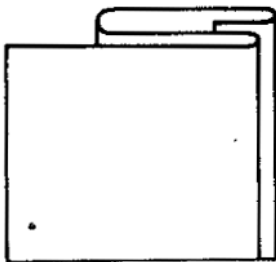

Fig. B

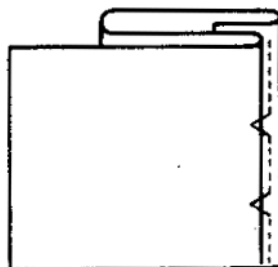
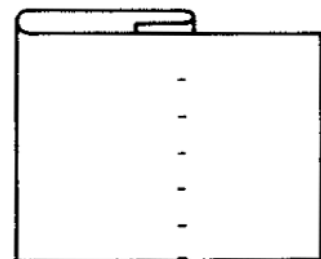
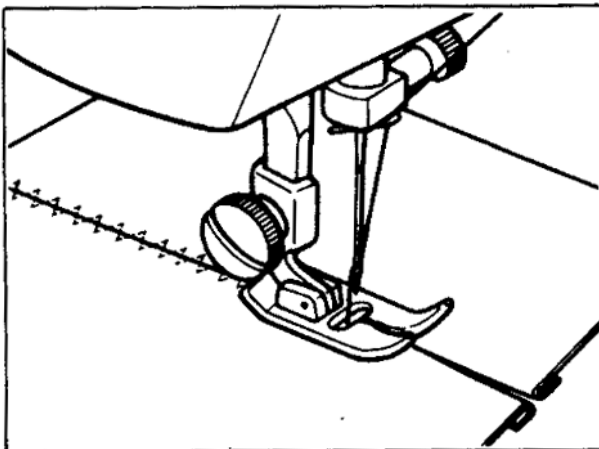
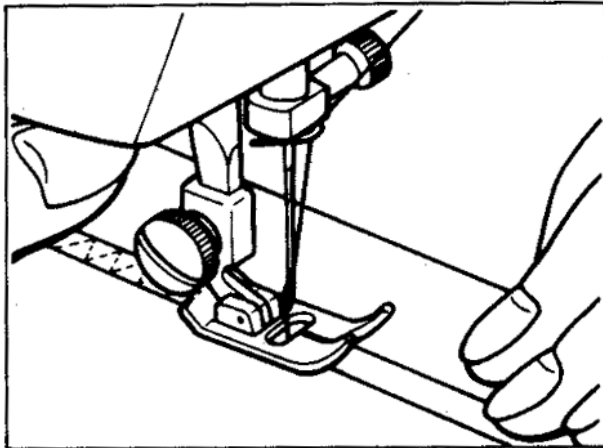
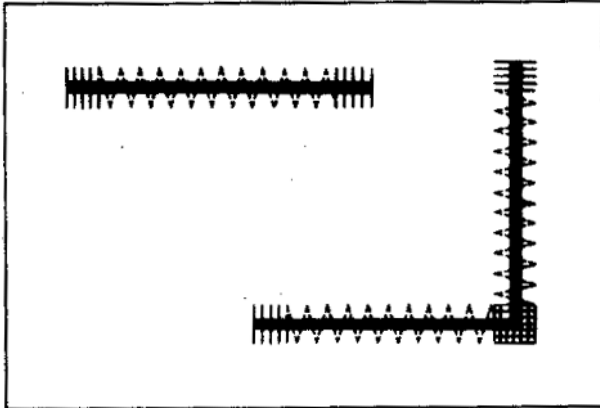

Fig. C



Elastic Stitch

PATTERN DIAL	: 4 (Elastic Stitch)
STITCH LENGTH DIAL	: 1 ~ 2
STITCH WIDTH DIAL	: 3 ~ 5
PRESSER FOOT	: Zigzag
NEEDLE	: Single
PRESSURE ADJUSTER	: 1 or 2



MENDING

1. Set stitch length dial between F-1.
2. Place reinforcement material under tear in material to be repaired.
3. Following the line of tear, sew elastic stitch so that both sides of tear are joined.

SEWING ELASTIC

1. Place the elastic on the material.
2. As you sew, stretch elastic both in front and in back of presser foot as shown in illustration.

JOINING STITCH

1. Elastic stitch is used to join material together.
2. Place material edge to edge under presser foot.
3. Sew together using elastic stitch. Care should be taken to keep the two material edges close together.

SEWING KNITS

Knitted garments are sewn by this elastic stitch effectively. Use nylon thread, and stitch will be invisible.

Link Stitch

PATTERN DIAL	: 6 (Link Stitch)
STITCH LENGTH DIAL	: 4
STITCH WIDTH DIAL	: 3 ~ 5
PRESSER FOOT	: Zigzag
NEEDLE	: Single or Twin
PRESSURE ADJUSTER	: 1 or 2

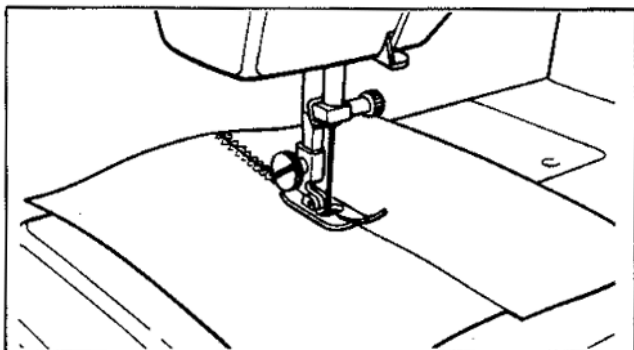

This stitch is ideal for smocking and it is useful for mending, overcasting and attaching elastic, stretch lace and blanket binding. Use this versatile stitch to create decorative designs on fabrics that stretch.

NOTE: If twin needle sewing is used, set zigzag width dial at under "3".

Elastic Overlock Stitch

PATTERN DIAL	: 7 (Elastic Overlock Stitch)
STITCH LENGTH DIAL	: 4
STITCH WIDTH DIAL	: 4
PRESSER FOOT	: Zigzag
NEEDLE	: Single
PRESSURE ADJUSTER	: 1 or 2

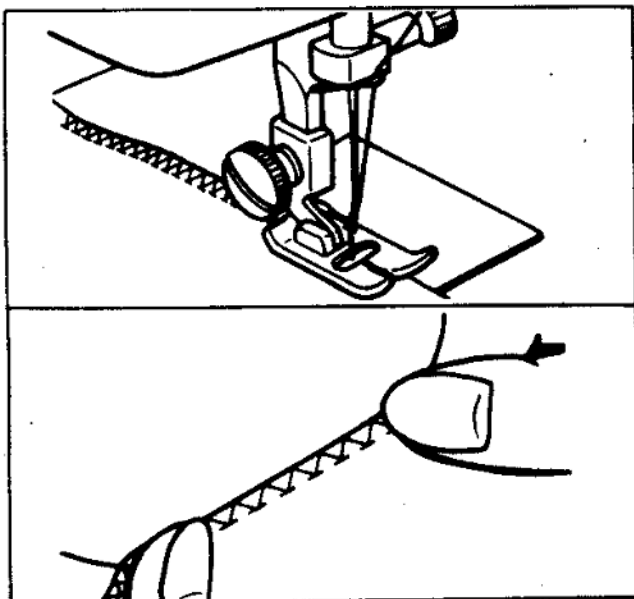

For stretch materials, an elastic overlock stitch can be made as follows:

Place edge of material under presser foot so that left side of straight stitch and right side of zigzag stitch appears and sew in this position.

Scallop Stitch

PATTERN DIAL	: 8 (Scallop Stitch)
STITCH LENGTH DIAL	: F
STITCH WIDTH DIAL	: 3 ~ 5
PRESSER FOOT	: Zigzag
NEEDLE	: Single or Twin Needle
PRESSURE ADJUSTER	: 1 or 2

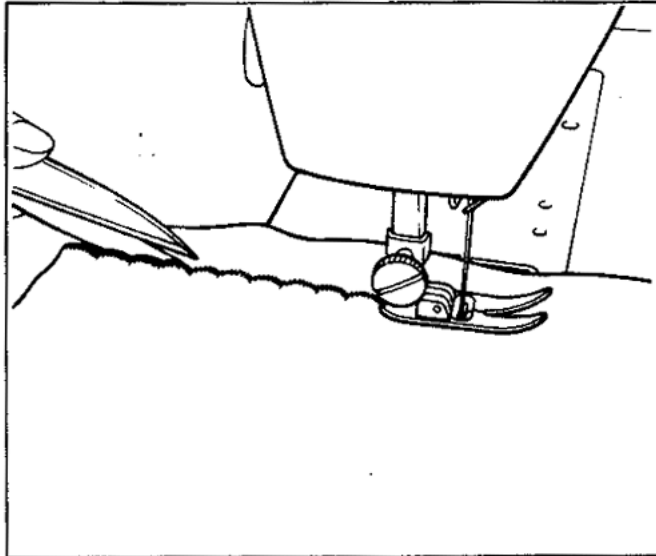

This machine produces decorative stitch (Scallop) automatically.

The "Scallop Stitch" may be used as a decorative edging.

1. Sew scallop stitch along edge of material.
2. If desired, trim around scallop with scissors to create a scallop edge.

NOTE: If twin needle sewing is used, set zigzag width dial at under "3".

Lighting Stitch

PATTERN DIAL	: 9 (Lightning Stitch)
STITCH LENGTH DIAL	: F
STITCH WIDTH DIAL	: 3 ~ 5
PRESSER FOOT	: Zigzag
NEEDLE	: Single or Twin
PRESSURE ADJUSTER	: 1 or 2

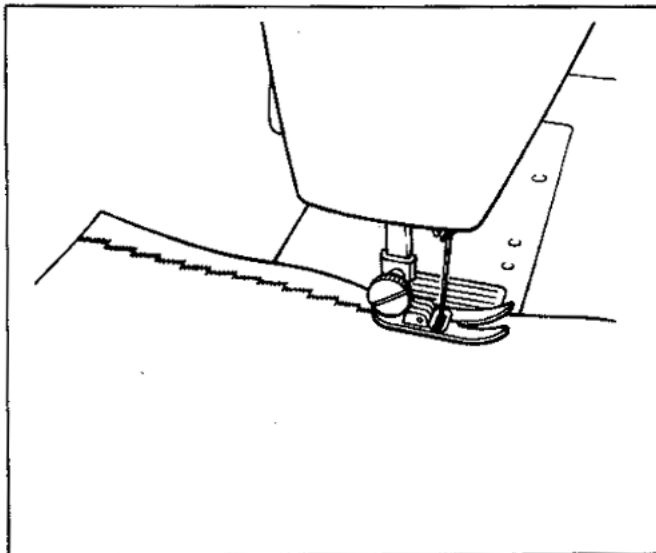

This stitch is designed for decorative use and can apply to clothes and household items. Using this stitch for border designs and smocking is recommended.

NOTE: If twin needle sewing is used, set zigzag width dial under "3".

6

Buttonholes and Button Sewing

Buttonholes

- PATTERN DIAL : A. B. C. D.
 STITCH LENGTH DIAL : F (Fine) ~ 3 (Coarse)
 STITCH WIDTH DIAL : See Instruction Below
 PRESSER FOOT : Buttonhole Foot
 FEED DOG : See Instruction Below
 NEEDLE : Single
 PRESSURE ADJUSTER : 1 or 2

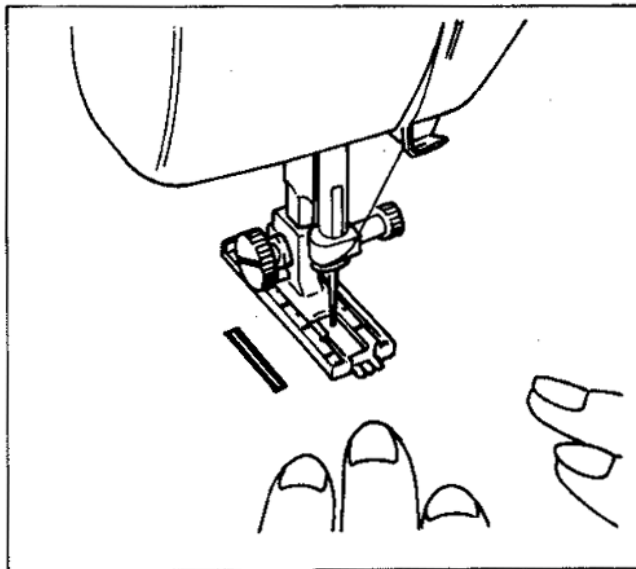

PREPARATION FOR MAKING BUTTONHOLE

1. Use buttonhole foot with sliding portion.
2. Choose the best stitch width (width of bar tack) between 3 to 5 to suit your work.
3. Using tailor's chalk, mark the length of buttonhole you require on the material.
4. Attach the buttonhole foot and push the sliding portion toward rear until it stops.
5. Place the material under the presser foot so that front end of bar tack can be sewn first.

NOTE: We suggest you to make a test sample before actual sewing.

PROCEDURE OF MAKING BUTTONHOLE

Step	Sewing portion	Position of pattern dial	How to sew
Step A (Front end of bar tack)			<ol style="list-style-type: none"> 1. Set pattern dial at A. 2. Lower presser foot and sew 5 to 6 stitches. 3. Stop machine and raise needle from the material.
Step B (Left side row)			<ol style="list-style-type: none"> 1. Turn the dial to the right and set at B. 2. Sew predetermined length. 3. Stop machine and raise the needle.
Step C (Back end of bar tack)			<ol style="list-style-type: none"> 1. Turn the dial to the left and set at C (same position as A). 2. Sew 5 to 6 stitches. 3. Stop machine and raise the needle.
Step D (Right side row)			<ol style="list-style-type: none"> 1. Set the dial at D. 2. Sew the right side row until the needle reaches position D.

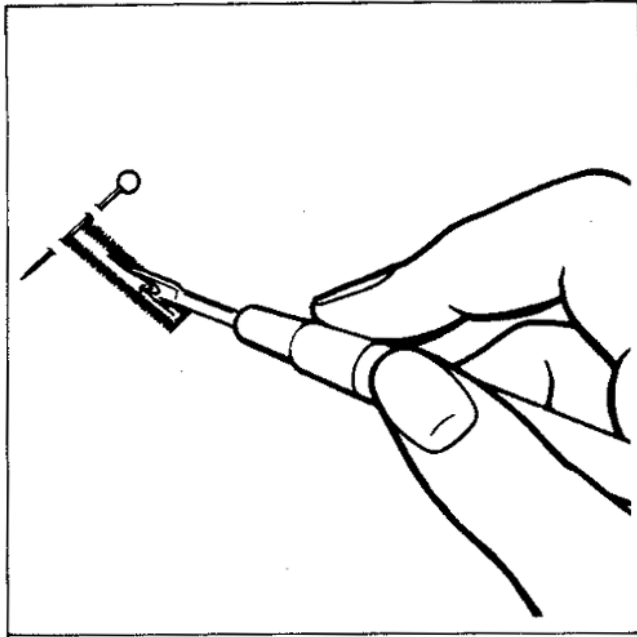

HOW TO SECURE STITCHING AND CUT MATERIAL FOR BUTTONHOLE.

1. To secure stitching, turn the material 90 degrees counter-clockwise and sew 5-6 straight stitches.
2. Remove from machine. Cut opening in buttonhole with seam ripper tool, taking care not to cut through any stitching.
3. It is recommended that pins are placed across both ends of buttonhole as protection against cutting bar tack stitching.

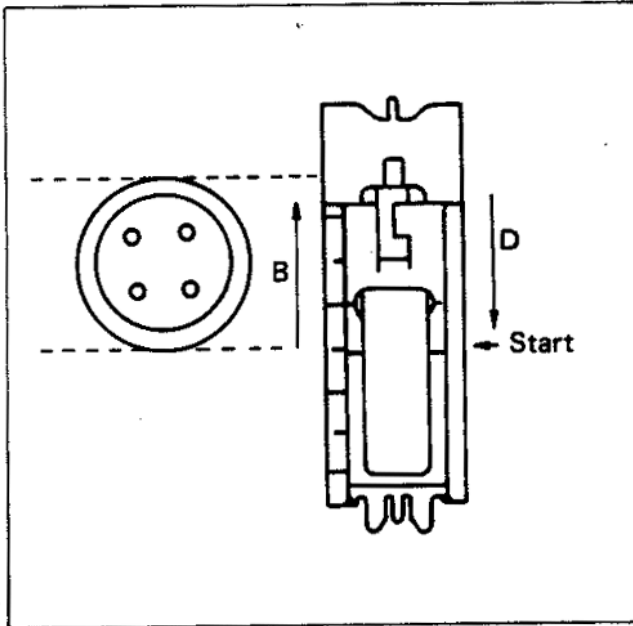

MAKING SEVERAL BUTTONHOLES OF THE EXACT SAME SIZE

1. Set the sliding portion of the buttonhole foot according to the size of the button and sew Step A.
2. Sew Step B until the sliding portion no longer moves.
3. Sew Step C.
4. Sew Step D until the sliding portion returns to Step A.
5. Repeat 1 through 4 for each additional buttonhole of the same size, using the same starting point.

Button Sewing

PATTERN DIAL	: 1
STITCH LENGTH DIAL	: 0
STITCH WIDTH DIAL	: This dial is used to control distance between holes in button.
PRESSER FOOT	: Button Sewing Foot
NEEDLE	: Single
PRESSURE ADJUSTER	: 1

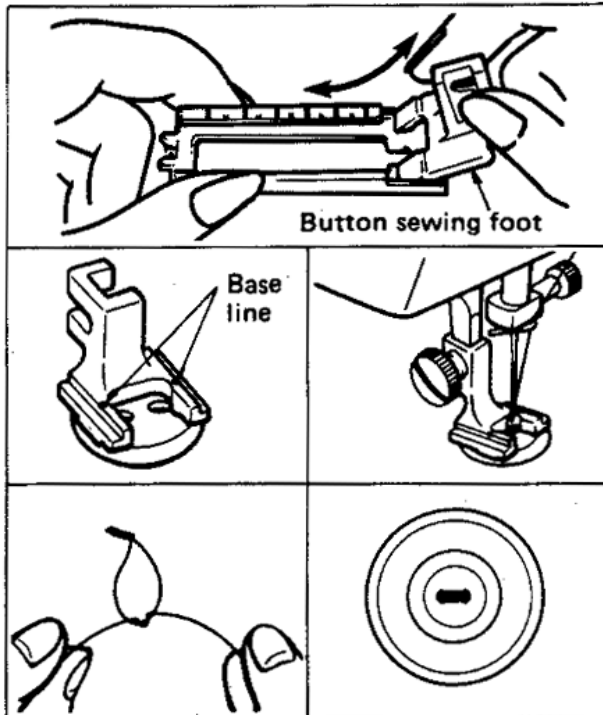

1. Removing the sliding portion of button-hole foot, you will have a button sewing foot.
2. Place button between the presser foot and the material, making sure that holes of button fall in line with the base line of button sewing foot.
3. Set stitch width control to regulate distance of stitch between the holes in the button. Lower presser foot and check to see that needle enters holes in button properly.
4. At slow speed sew approximately 10 stitches.
5. Remove from machine. Cut upper and lower threads and with normal sewing needle sew threads through to back of button and tie.

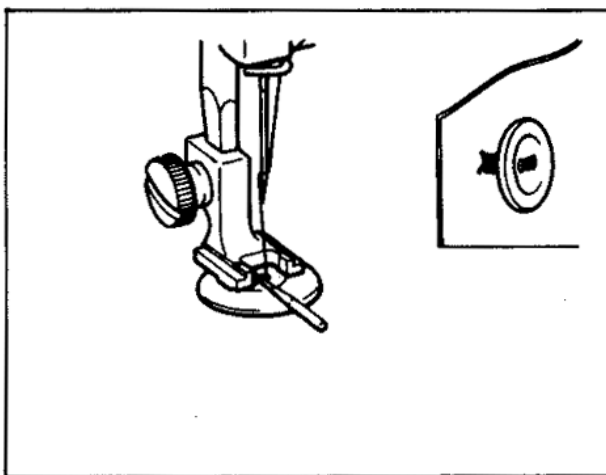

BUTTON FITTING WITH THREAD SHANK

You will often need the thread shank of button for heavier materials.

1. Place a needle on the button as illustrated and sew as regular method of button fitting.
2. After about 10 stitches, remove the fabric from the machine, leaving upper thread little longer in order to form a thread shank.
3. Pull upper thread between the button and the material through the hole of button and upper thread tightly around the stitches.
4. Fasten the thread ends.

Zipper Insertion

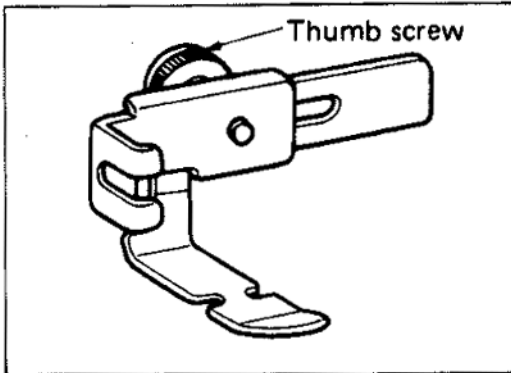

Zipper foot is used to sew various types of zippers and can easily be positioned to right or left side of needle. When zipper is being sewn at right side of needle, position zipper foot by loosening thumb screw and sliding zipper foot to the left.

When the zipper is being sewn at left side of needle, position zipper foot by loosening thumb screw and sliding zipper foot to the right.

PATTERN DIAL	: 1
STITCH LENGTH DIAL	: 2-3
STITCH WIDTH DIAL	: 0
PRESSER FOOT	: Zipper Foot
NEEDLE	: Single
PRESSURE ADJUSTER	: 1 or 2

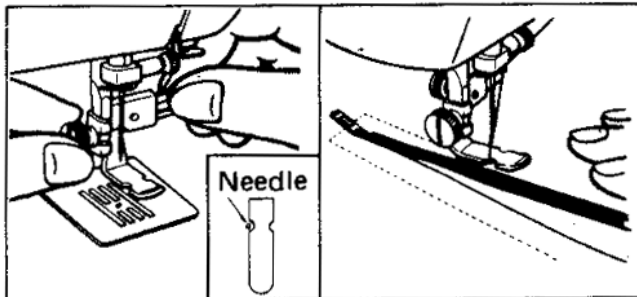

1. Lower needle into side notch located on presser foot (right or left).
2. Tighten thumb screw to lock presser foot into position.
3. Fold edge of material 3/4 inch (2 cm.) and place zipper under folded portion.
4. By guiding zipper foot along the zipper teeth you will stitch close to edge of zipper in correct position.
5. To sew opposite side of zipper loosen thumb screw and position zipper foot (right or left).

Gathering

PATTERN DIAL	: 1
STITCH LENGTH DIAL	: 4
STITCH WIDTH DIAL	: 0
PRESSER FOOT	: Straight
NEEDLE	: Single
PRESSURE ADJUSTER	: 1 or 2

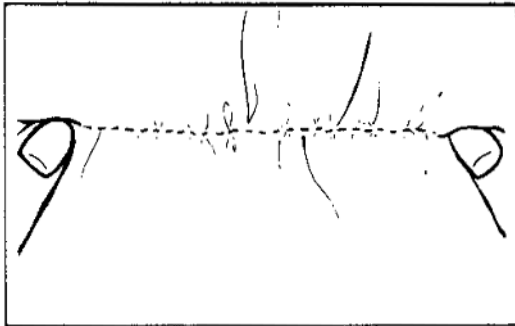

1. Loosen upper thread tension (set dial at about '2') so that lower thread lies on the under side of material.
2. Sew a single row or multiple rows of straight stitching.
3. Pull lower thread(s) to gather up material.

Attaching Lace

PATTERN DIAL	: 1
STITCH LENGTH DIAL	: 2-4
STITCH WIDTH DIAL	: 0
PRESSER FOOT	: Zigzag
NEEDLE	: Single
PRESSURE ADJUSTER	: 1 or 2

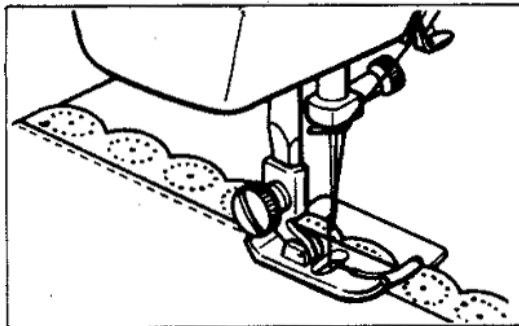

1. Place lace under material letting it overlap edge 1/4 inch (5 mm).
2. Place under presser foot and sew.

NOTE: If satin stitch or a decorative stitch is used to sew lace, it will be most decorative.

Appliqueing

PATTERN DIAL	: 1
STITCH LENGTH DIAL	: F-2
STITCH WIDTH DIAL	: 1-3
PRESSER FOOT	: Zigzag
NEEDLE	: Single
PRESSURE ADJUSTER	: 1

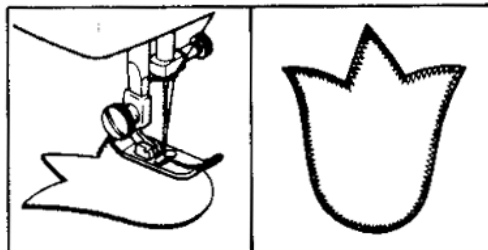

1. Baste cut design to the material.
2. Sew carefully following design.
3. Cut away surplus material outside of stitching.
4. Remove basting.

NOTE: Make reinforcement straight stitch at initial and final sewings.

Cording

PATTERN DIAL	: 1
STITCH LENGTH DIAL	: F-2
STITCH WIDTH DIAL	: In accordance with thickness of cord being used, set stitch width.
PRESSER FOOT	: Zigzag
NEEDLE	: Single
PRESSURE ADJUSTER	: 1

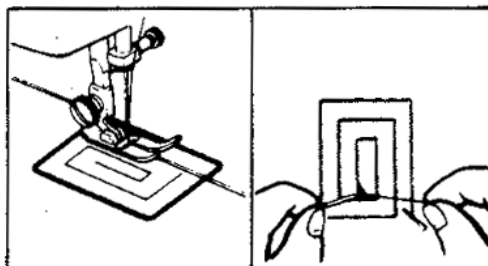

1. Set Stitch Width Dial.
2. Place cord on fabric to be sewn.
3. Lower presser foot making sure cord is centered and sew using zigzag stitch. Guide cord by hand to where you desire it.

Darning

PATTERN DIAL	: 1
STITCH LENGTH DIAL	: Set at any position
STITCH WIDTH DIAL	: 0
PRESSER FOOT	: Straight
NEEDLE PLATE	: Zigzag
NEEDLE	: Single
PRESSURE ADJUSTER	: 0
OTHERS	: Darning plate

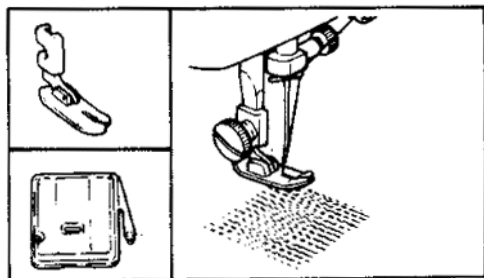

1. Place darning plate on needle plate.
2. Place material with area to be darned under presser foot.
3. Lower presser foot.
4. Stitch by slowly drawing material back and forth.
5. Repeat until area to be darned is completely filled in.

Monogramming and Embroidering, Using Embroidery Hoop

PATTERN DIAL	: 1
STITCH LENGTH DIAL	: Set at any position
STITCH WIDTH DIAL	: 0-5
PRESSER FOOT	: Removed
NEEDLE	: Single
OTHERS	: Darning plate

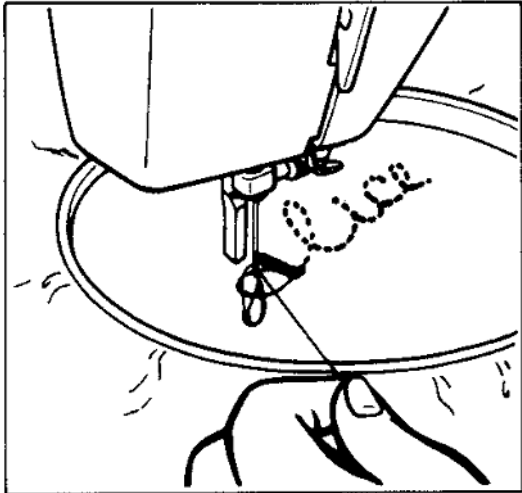

PREPARATION FOR MONOGRAMMING AND EMBROIDERING

1. Place darning plate on needle plate.
2. Set your sewing machine as per side instructions.
3. Draw lettering (for monogramming) or design (for embroidering) on the right side of the material.
4. Stretch work between embroidery hoops as firmly as possible.
5. Place the work under the needle and lower presser bar.
6. Pull lower thread up through the work as starting position by turning balance wheel and make a few holding stitches.
7. Hold the hoop with thumb and forefingers of both hands while pressing the material with middle and third fingers and supporting the outside of hoop with smaller finger.

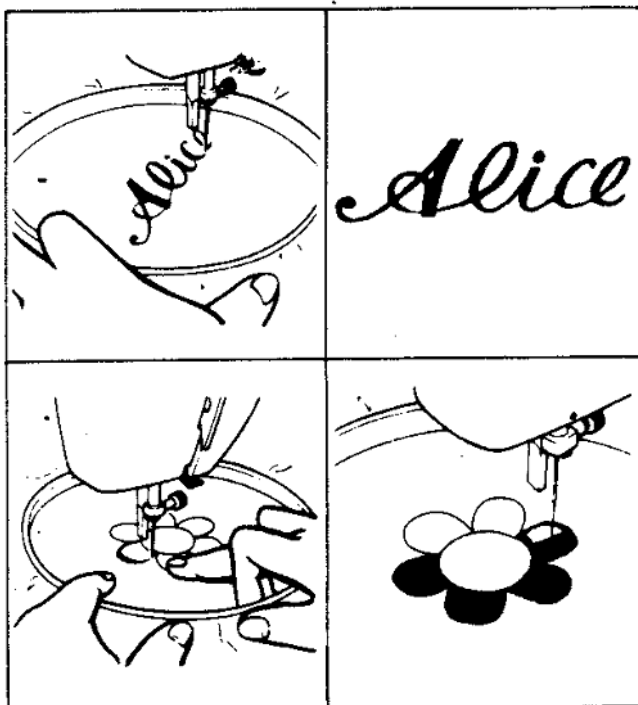

MONOGRAMMING

1. Sew, moving hoop slowly along the lettering at an even rate of speed.
2. Secure with a few straight stitches.

(NOTE: These instructions also apply to embroidering)

EMBROIDERING

1. Stitch outline of design by moving embroidery hoop accordingly.
2. Fill in design stitch from outline of design to inside and from inside to edge of outline alternately until design is completely filled in. Keep stitching close together.

NOTE: A long stitch is made by moving embroidery hoop rapidly and a short stitch is made by moving it slowly.

Cleaning

The sliding parts of the shuttle race should be cleaned regularly so that lint does not accumulate.

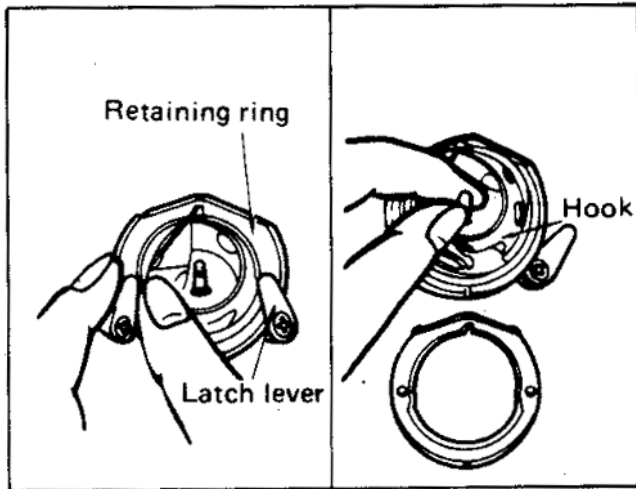

HOW TO REMOVE THE SHUTTLE HOOK

1. Raise needle to its highest position.
2. Open shuttle cover.
3. Take out bobbin case.
4. Push latch levers outside and remove retaining ring.
5. Remove hook by grasping center post of hook.

NOTE: When needle is lowered, shuttle hook cannot be removed.

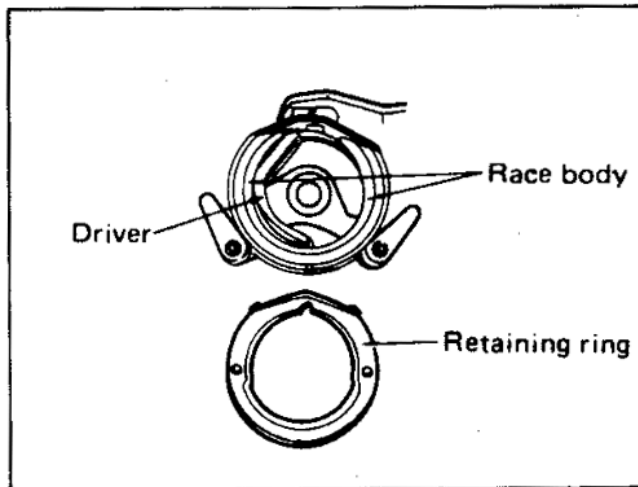

CLEANING SHUTTLE RACE

1. Remove accumulated lint and thread from the retaining ring, hook, driver and race body with brush.
2. A cloth dampened with machine oil should be used to wipe shuttle race clean.
3. Clean shuttle hook in same manner as above.
4. Reassemble.

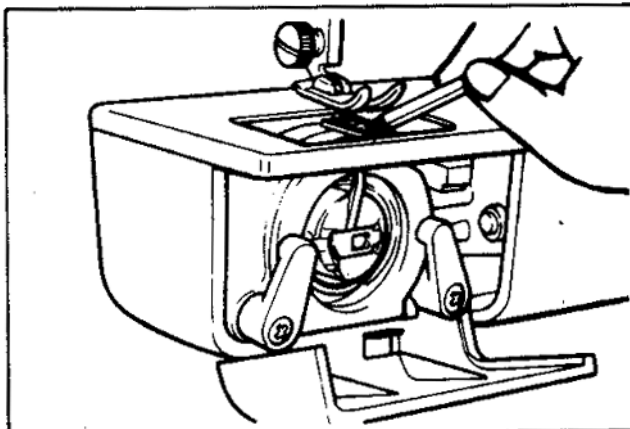

CLEANING FEED DOG

1. Take out needle plate.
2. Clean upper part of feed dog and shuttle race body with brush.

How to Oil Sewing Machine

For smooth and silent operation the moving parts of the machine should be oiled periodically. (See diagram below.)

OIL 1 to 2 DROPS TO THE POINTS MARKED



OIL 3 to 4 DROPS TO THE POINTS MARKED



OIL ONCE A WEEK IF MACHINE IS USED MORE THAN ONE HOUR PER DAY. IF MACHINE IS USED MORE OFTEN OIL EVERY DAY.

After the machine has been oiled, remove thread and with presser foot up, run machine fast. Then wipe up any excess oil.

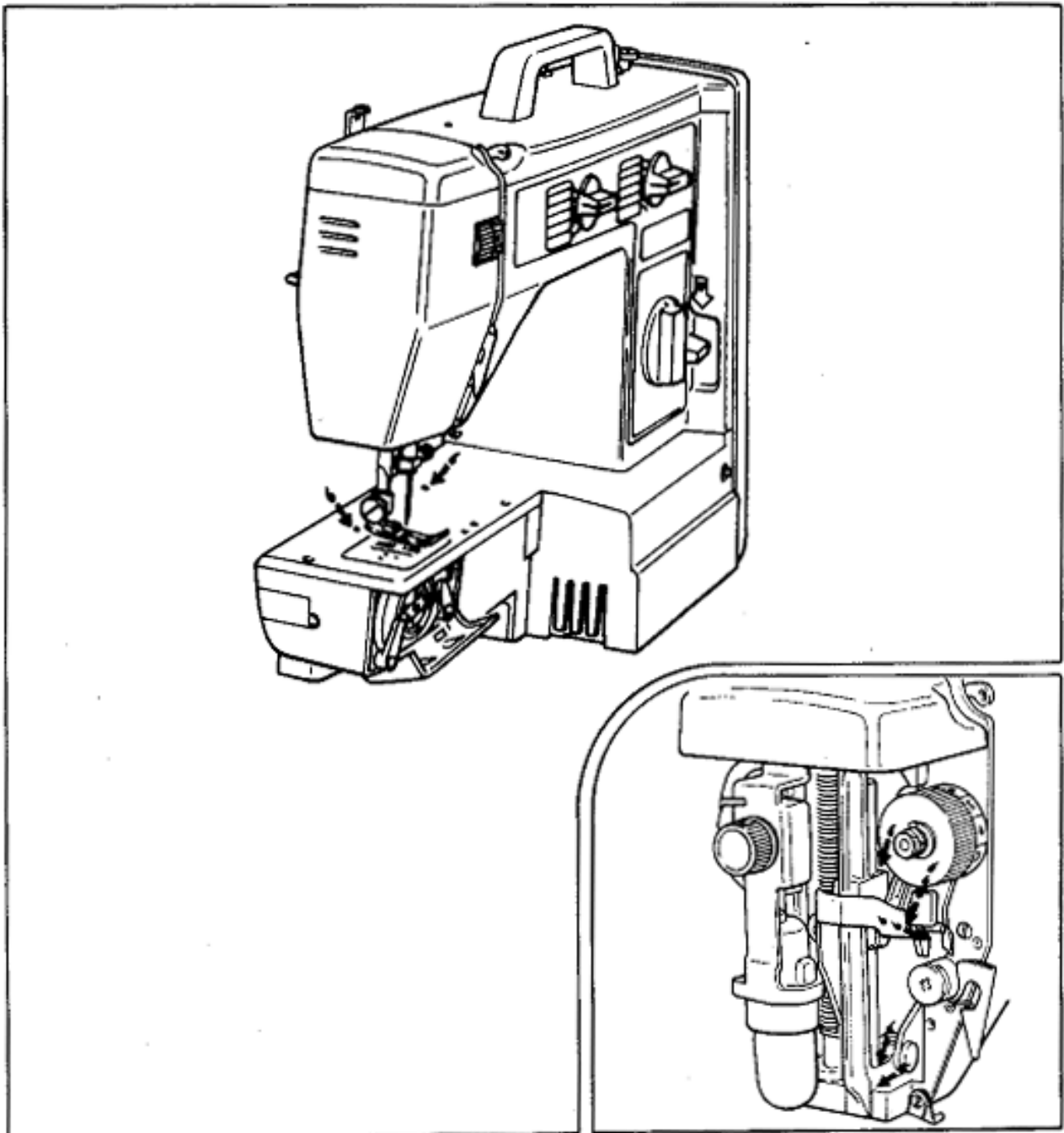

Occasionally, remove the top cover by loosening two screws on it and apply machine oil to oiling points as illustrated. Also, apply machine oil to inner parts of free-arm as illustrated by loosening two screws.

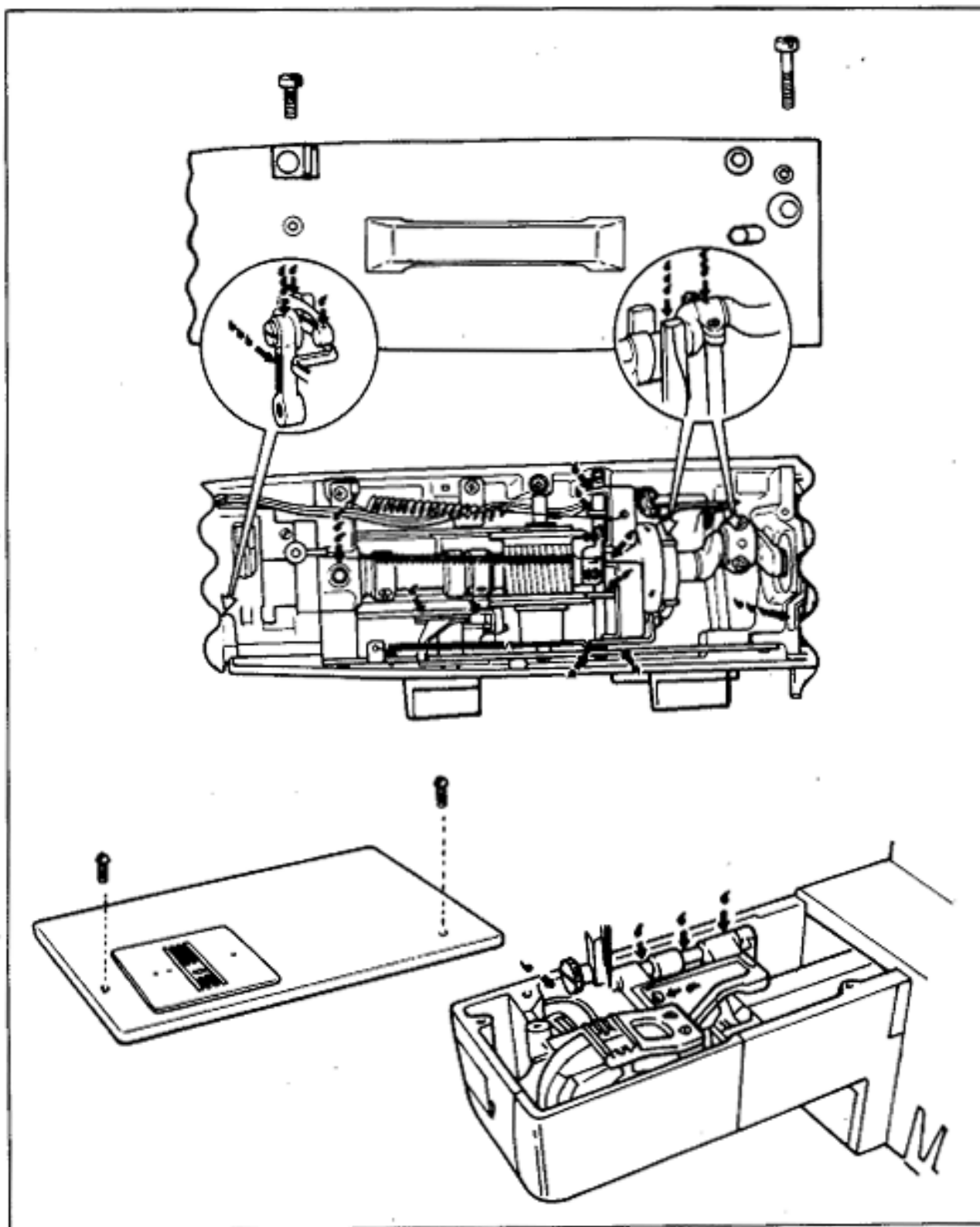

NOTE: If machine has not been used for a long period of time, oil tends to coagulate and operation of machine will not be smooth. Apply a few drops of oil to oiling points, and with presser foot up run machine for a few minutes. Then wipe up any excess oil.

Check List for Better Sewing

Check this list if you are having the following problems:

IF MATERIAL IS NOT FED

1. Darning plate is on the needle plate.
2. Needle plate is out of position.
3. Stop motion knob is loose.
4. Stitch length regulator is at 0.

IF NEEDLE BREAKS

1. Needle is inserted incorrectly.
2. Needle clamp screw is loose.
3. Bent needle is used.
4. Upper threading is not correct.
5. Upper thread tension is too tight.
6. Wrong needle and thread for cloth being sewn are used.
7. Material pulled excessively.

IF LOOPS FORM ON FABRIC

1. Tension of upper or lower thread is wrong.

IF MATERIAL SHOULD PUCKER

1. Thread tension is too tight.
2. Threading is not correct.
3. Thread is caught by something.
4. Lower thread is unevenly wound on bobbin.

IF LOWER THREAD BREAKS

1. Lower thread is entangled in shuttle.
2. Lower thread tension is too tight.
3. Lower threading is not correct.

IF MACHINE SKIPS STITCHES

1. Needle is not sharp and straight.
2. Needle is inserted incorrectly.
3. Wrong needle and thread for cloth being sewn are used.
4. Upper threading is not correct.
5. Lint is clinging to under-side of needle plate.

IF LOWER THREAD BREAKS

1. Lower thread is entangled in shuttle.
2. Lower thread tension is too tight.
3. Lower threading is not correct.

IF MACHINE RUNS HEAVY OR NOISY

1. Machine is out of oil.
2. Lints is accumulated on shuttle and teeth of feed dog.

Repacking the Machine

Keep this carton and packing material for future use in the event it becomes necessary to reship the sewing machine.

(Improper packing or improper packing material could result in damage during shipping.)
Instructions for repacking the machine are illustrated below.

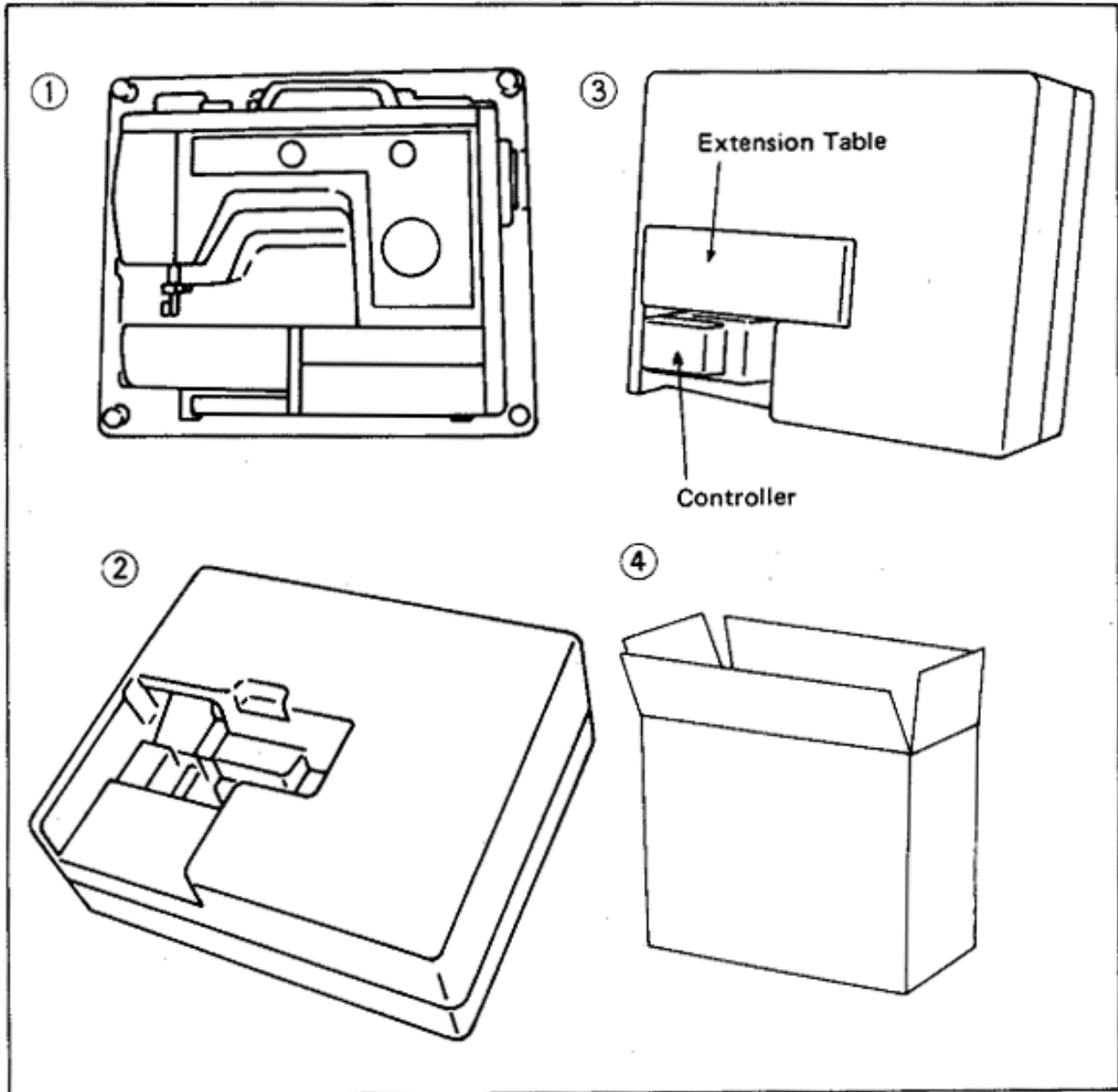

Index

Accessories.....	4
Appliquéing.....	31
Attaching lace.....	30
Blind stitch.....	22
Button-holes.....	26
Button sewing.....	28
Check list for better sewing.....	36
Cleaning.....	33
Cording.....	31
Darning.....	31
Decorative stitches.....	20
Elastic overlock stitch.....	24
Elastic stitch.....	23
Extension table.....	10
Gathering.....	30
How to oil sewing machine.....	34
Link stitch.....	24
Lower (bobbin) thread.....	12
Machine cover.....	3
Monogramming and embroidering.....	32
Needle.....	8
Operating your sewing machine.....	5
Pattern dial.....	6
Presser foot.....	8
Pressure adjuster.....	7
Principal parts.....	2
Relative chart of sewing material, needle and thread	9
Repacking the machine.....	37
Reverse sewing lever.....	7
Satin stitch.....	19
Scallop stitch.....	25
Sew light.....	10
Shell stitch.....	21
Simple zigzag stitch.....	19
Stitch length dial.....	6
Stitch width dial.....	7
Straight stitching.....	17
Thread tension.....	15
Triple stretch stitch.....	21
Upper (needle) thread.....	11
Zipper insertion.....	29

MEMO

MEMO

MODEL VX780
ENGLISH
191578-0-11



Replacement Sewing Manuals

From
<http://www.mastersewusa.com>

Thank you for your purchase.

We try to scan original manuals at the highest DPI settings without compromising the readability of the manual. We also have a technical team that has been working over a year retyping hard to find and in poor shape manuals from many different manufacturers. During the retype operation the technicians try their best to maintain the wording and page set up as of the original manual.

If you are satisfied with this product please tell others about us. Many of our sales are made to people who heard of us by referrals of customers like you. Many homes have sewing machines but their manuals became lost or damaged.

We are here 24/7 on the Internet at:

<http://www.mastersewusa.com>

We have Instructional manuals, service manuals, parts lists, and instructional videos for many industrial and consumer sewing machines.

We assist owners of older Singer sewing machines by using their machines serial number and converting it to their sewing machines model number. Contact us at: sales@mastersewusa.com

Mastersewusa is committed to adding manuals to our library to consistently improve our service in the sewing community.

Our manuals are:

**BERNINA * BROTHER * CONSEW * FEIYUE-YAMATA * ELNA
* GN * PFAFF * JUKI * MORSE * NECCHI * NEW HOME *
SEARS KENMORE * SIMPLICITY * SINGER * WHITE**

For Reprints Visit on the web. <http://www.mastersewusa.com>

May 2006

Free Manuals Download Website

<http://myh66.com>

<http://usermanuals.us>

<http://www.somanuals.com>

<http://www.4manuals.cc>

<http://www.manual-lib.com>

<http://www.404manual.com>

<http://www.luxmanual.com>

<http://aubethermostatmanual.com>

Golf course search by state

<http://golfingnear.com>

Email search by domain

<http://emailbydomain.com>

Auto manuals search

<http://auto.somanuals.com>

TV manuals search

<http://tv.somanuals.com>