

Walk-In Cooler & Freezer Installation/Maintenance & Owner's Instructions

For All W. A. Brown & Son, Inc. Models



W.A. Brown & Son, Inc.
209 Long Meadow Drive • Salisbury, NC 28147
Phone: 704-636-5131 • Fax: 704-637-0919
Website: www.wabrown.com

Table of Contents

	Page No.
Cam Lock Installation	3
Door Section Maintenance	17-19
Drop Off (factory assembled) Walk-Ins	11
Duro-Last Roof Cap Installation	8
EZ Pack Refrigeration Installation	12
Fiber Cement Panel Installation	9
Final Check List & Cleaning	12
Floor Preparation & Installation	2
Treadplate Overlay	2
Floorless Walk-In Layout & Installation.....	3
How to Call for Service	15
Membrane Roof Cap for Outdoor Units	7-8
Multiple Compartment Installation	6-7
Quick Set Roof Cap & Curb Installation	13
Replacing a Pressure Relief Port	22
Receiving and Uncrating.....	1
Replacing Door Gasket.....	20
Replacing Door Heater Cable.....	19
Replacing the Digital Thermometer	22
Replacement Parts Ordering	15
Terminology.....	1
Top Panel Installation	6, 10
Trouble Shooting Guide	26
Wall Panel Installation.....	5
Wainscotting Installation	5
Warranty	16
What to do when there is Freight Damage.....	1
Wind or Seismic Load Installation	4
Wiring Diagrams	23-25
TAI200D Alarm	27

Receiving and Uncrating

Congratulations! You have purchased a brand new W.A. Brown & Son, Inc. Walk-In Cooler or Freezer. To ensure proper set-up and many years of trouble free use, read and follow these instructions carefully before and during installation. This manual covers the basic installation of a standard walk-in. See sheets enclosed with shipment for installation instructions for items not covered in this manual.

If You Have Freight Damage:

Brown walk-ins are shipped on pallets with shrink wrap, in dedicated trucks or in specially marked and designated cartons. These methods have been chosen to decrease the possibility of freight damage, however, each shipment should be inspected for exterior damage. If damage is found, please note it on the delivery freight bill and call W. A. Brown Customer Service. Under NO conditions may a damaged unit be returned to W. A. Brown & Son, Inc. without first obtaining permission.

Checklist Suggestions:

- Read and understand the installation manual and cooler drawings before attempting to install the walk-in.
- Make sure you have the number of pallets or crates listed on the Bill of Lading.
- Remove all panels from their shipping cartons and stack them in rows of like panels; wall panels in one row, ceiling panels in another, etc. Panels with a 6" yellow sticker are non-standard panels and have a particular location in the walk-in. This number can be found on the drawing identifying the location of these panels. All standard panels are interchangeable. You do however, have to put the proper size in the proper location.
- The refrigeration should be inspected upon receipt.
- Check the shipping list to insure you have the correct number of panels, doors and accessories. If any problems are found, please contact the factory as soon as possible.
- Locate accessories box for buttons, assembly wrench and a drawing.
- Panels that have a PVC protective covering on the metal skins should have the PVC removed as the panel is selected for installation. This will make removal of the PVC easier.
- It is recommended to use two people to handle panels. For door sections and larger panels a dolly or pallet jack may be useful.
- If panels must be stored on a job site prior to installation, it is recommended that they be stored inside. Panels received on skids or in cartons, should be stored as received, provided the skid or carton is on a level surface and kept free from moisture. If the panels are received without crating, they should be stored on edge with the female edge of the panel down. (Stacking may cause damage.)
- Your door and section will be labeled with an ID# such as 1D, 1D1, 2D, etc. This ID# along with your drawing will help you locate the door and section in the proper position.

Terminology

Panel Identification Labels

- W.A. Brown Panel Identification (On inside skin of panel and in foam edge) includes shop order number, due date, part number, description, notes, builder number, frame number, and date.
- Special Panel Identification (Round yellow label) includes part number and detail number and corresponds to a detail and location on the drawing.
- U.L. Label (on inside skin of panel) includes U.L. testing information on flame and smoke spread.

Panel Description

- USC (M or F) = Urethane Sidewall Corner (Male or Female)
- USMF = Urethane Sidewall Male Female
- USTM (or F) = Urethane "T" Sidewall Male (or Female)
- UTMF = Urethane Top with Male and Female edges
- UTOSM (or F) = Urethane Top Out Side Male (or Female)
- UTMFW/M (or F) = Urethane Top Male Female w/Male end (or Female)
- UBMF = Urethane Bottom Male Female
- UBOSM (or F) = Urethane Bottom Out Side Male (or Female)
- UBMF W/M (or F) = Urethane Bottom Male Female w/Male end (or Female)
- For Door definitions, see pages 17-19

Floor Preparation and Installation

Installation instructions are provided for walk-ins with insulated floor panels or walk-ins set on spline. Instructions are also provided for the application of walk-ins in areas requiring adherence to wind or seismic loads.



Warning! A level walk-in is essential. If the floor is not level, the vertical panels will not be plumb and the hinged door will not operate properly and panels will not seal properly.

Layout of the Floor

Check the floor plan of the walk-in for the exact location of the floor panels as indicated on the floor panel layout drawing which is furnished with each walk-in. The building area on which the walk-in is to be erected should be chalked to the base of the box. If the walk-in is to be erected next to an existing wall a 2" clearance should be allowed for surface irregularity. Set-up 'Builders Level' per instructions. Take readings at selected intervals on a story pole to determine the highest point of floor assembly. Mark the high point and shim to this level.

Shims of 24 to 12 gauge sheet metal or cedar wood are recommended. Shims should be cut a minimum 4" x 4". Shims must extend under the whole section, not just the edges. Shims should be at each end, at all wall seams and at each floor seam. All shims should be no further than 12" apart. Shimming will reduce load limits. Shims are not supplied with shipment. An alternate method of leveling is to level the unit by filling in with a level bed of sand. Cover the sand with a poly film or asphalt paper before installing the floor. See Figure #1.

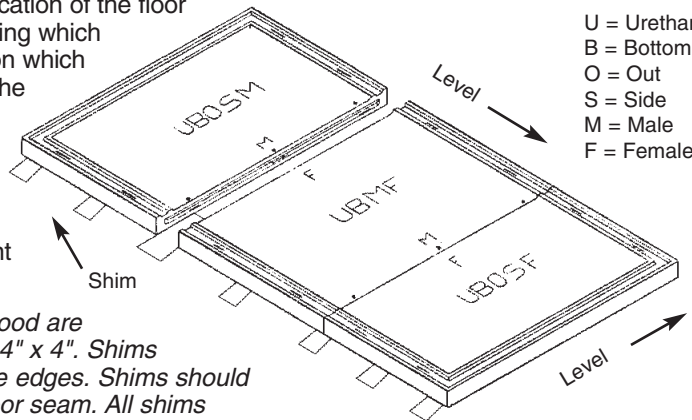

Figure #1

U = Urethane
B = Bottom
O = Out
S = Side
M = Male
F = Female

Installation of floor panels

Installation of the floor may begin when the floor leveling is complete. Refer to the floor panel layout drawing which has been furnished with the walk-in. Begin installing the floor with an end panel. Continue until all panels are set and are level. Engage all cam locks as the panels are installed. Recheck levelness of the floor panels after all are complete.



Warning! Position the floor panels per the drawing to ensure that the door will be properly placed. In multiple compartment walk-ins with a partition section, it is imperative that the panels be located in proper position and turned correctly so that walls and tops will lock securely.



Warning! Attention Floor Contractors: Some chemicals and vapors in field applied floor materials can cause metal corrosion. Use extreme care to keep these materials off of metal surfaces and to keep doors open fully and the cooler ventilated until inside flooring is cured.

Diamond Aluminum Treadplate Overlay Instructions

All treadplate material will be cut to size, to match the entire interior surface less 1/2" on all four sides.

1. Clean and dry subsurface
2. Apply silicone to underside of treadplate
3. Begin laying first row of Treadplate Overlay 1/2" away from the edge of the floor according to the Drawing and secure the subsurface with sheet metal screw/anchor.
4. All sheets must be flush as possible with one another.
5. All sheets can be secured using a sheet metal screw every 24".
6. Continue to follow the layout of treadplate according to the drawing until all sheets are flush and secure to the subsurface.
7. Caulk all seams and edges of treadplate layout.
8. Allow 1-3 hours to dry before resuming use of walk-in.

Cam Lock Installation

All panels are connected with a mechanical Cam lock which is activated by using a hex wrench (included with your shipment). There are both a male section, and a female section. The locks are foamed in place and securely anchored to provide a solid connection, when the locking arm is tightened around the locking pin which is located in the female section.

To operate the latch, insert the wrench through the access hole which is located on the inside of each panel. Turn the wrench counter-clockwise to fully unlock and retrieve the locking arm. Pushing together the two panels you wish joined, you will then turn the wrench one quarter turn clockwise. Continue to turn the wrench until you feel the panels lock together. You should feel the lock hit the stop position.

Some custom panels may have specialized lock locations. They will be so marked. Follow those markings when connecting these panels.

Make sure you have the panels in the correct and final position before locking, as continued locking and unlocking may result in less than satisfactory operation.



Floorless Walk-In Layout

Floor Spline Layout and Installation



Warning! When W. A. Brown does not provide the insulated floor, check carefully before installing the walk-in for appropriate thermal breaks. Severe floor heaving problems occur when floors are not adequately insulated. Consult the W. A. Brown Working Data Catalog for details.

1. Mark on the building floor the exact area the walk-in will occupy.
2. Lay the spline out as indicated on the spline layout drawing (See Figure #2) which is furnished with each walk-in. Each section is numbered and must be layed out as shown in order for the wall panels to lock down properly. Measure diagonally from corner to corner to be sure the floor spline is square.
3. The entire floor spline must be leveled from the highest point.



Warning! On walk-ins larger than 10' x 10' it is recommended that a transit level be used to level the floor spline rather than a spirit level.

4. Determine where shims are needed for leveling, and cut them to the width of the spline. (W. A. Brown does not furnish these shims.)
5. Fasten the spline to the floor using ramset studs, screws, expansion bolts, etc. (See Figure #3)
6. Seal all open areas between the spline and floor using grout or a siliconesealant. (Not provided by WAB.)
7. Seal all joints between sections of spline, similarly to above.
8. Locate and install metal NSF cove molding after walls are installed.

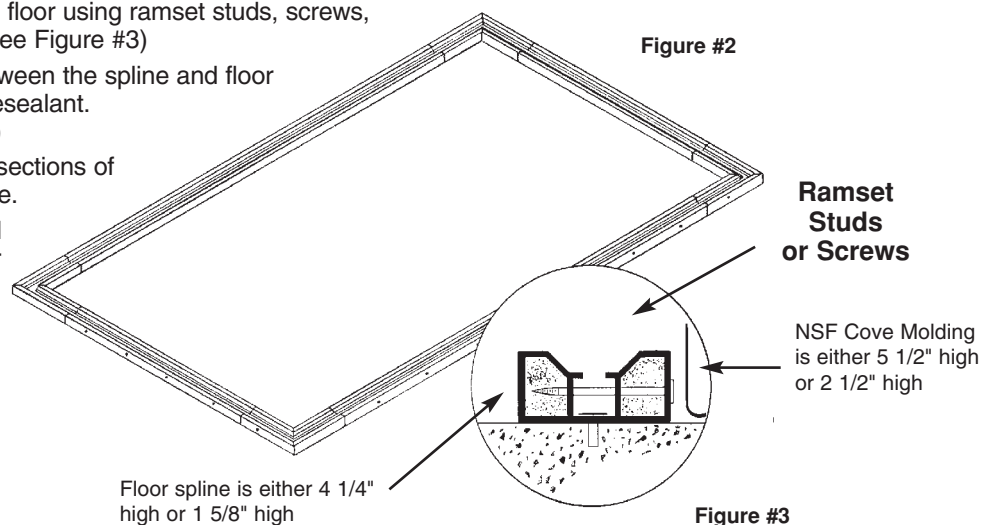

Installation of floor panels secured for seismic and wind - exterior applications

After the floor is installed per the instructions above, obtain the hardware and tools for the application of "Tapcon" anchors.

1. 1/4" "Tapcon" Phillips flat head anchors or equal
2. "Tapcon" drill bit; 3/16" x 6 1/2" (No. 790-1036 or equal)

Drill through the female cam lock located in the floor panel into the concrete pad to a depth of 2" or more to insure the anchor does not bottom out. (If leveling shims are required, locate shims close to the location of the anchors) Space holes around the perimeter of the floor system at each cam lock location (eliminate anchors when space is less than 15" from previous anchor) spaced no further than 24". Insert and tighten the "Tapcon" anchors into each hole. **DO NOT OVER TIGHTEN.** Recheck floor for level and square prior to installation of walls.

PVC Panel Track Installation for Floorless Walk-In



Warning! When W. A. Brown does not provide the insulated floor, check carefully before installing the walk-in for appropriate thermal breaks. Severe floor heaving problems occur when floors are not adequately insulated. Consult the W. A. Brown Working Data Catalog for details.

PVC Panel Track Layout (Required where no insulated floor is ordered from Brown)

1. Mark the exact area the walk-in will occupy on the building floor.
2. Field cut 12' pieces of the PVC panel track to size for your particular walk-in. Cut ends on a 45 degree angle to accommodate corner panels. A hack saw will work well for this cut. (See Figure #4)
3. Mark and cut door opening location.
4. Fasten track to the floor using ramset studs, screws or other fasteners (not supplied by WAB.) (See Figure #5)
5. Determine where shims are needed for leveling, cut them so they will fit in the channel of the track. The wall panels are leveled during the installation process.
6. Seal all open areas around the track using silicone sealant (not provided by WAB.)
7. The wall panels do not lock to the track in this application.

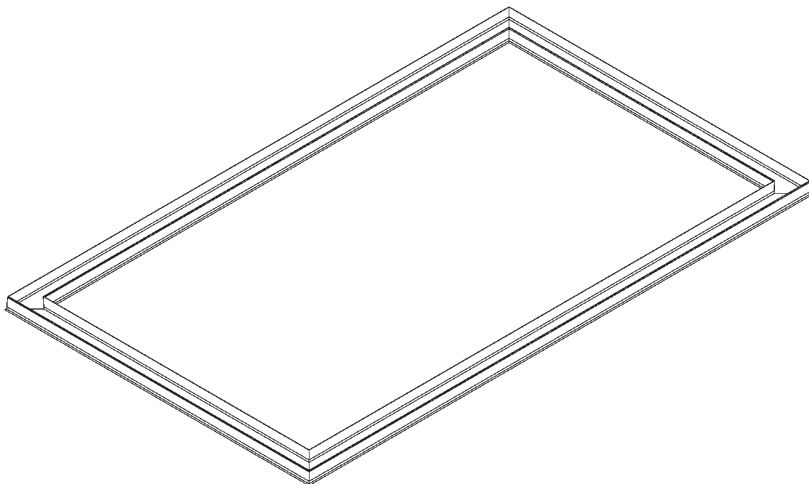

Figure #4

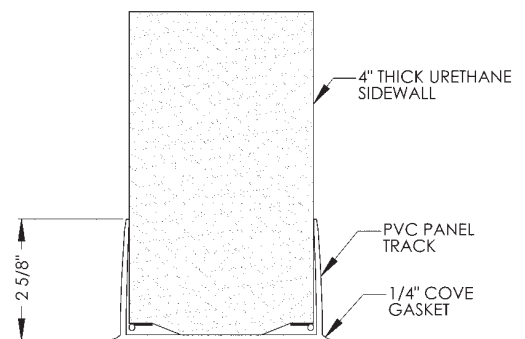



Figure #5

Wall Panel Installation

See separate instructions for installation if box has multiple compartments (page 6-7) with a "Tee" panel.

1. Start installation at the corner panel nearest the door or, if cooler is to be installed in a corner, start with the corner located on the inside. (See Figure 7) Place the first corner panel into position. Be sure the 'arrow' is pointed up and the male tongue of the panel (edge w/cam locks) is on the right side when standing inside the walk-in.
2. When locks are in standard positions, rotate clockwise to engage the locking pin. Refer to prints for locks that are special applications: lock counter-clockwise, lock from exterior of panel, etc.
3. Install a wall panel on each side of the corner panel for stability. Make sure that all wall panels are even at the top.
4. Continue to install all wall and corner panels. Next install the wall containing the door. This provides better support for correct setting of the door.
5. Be sure to engage all cam locking devices in each wall panel. After all wall, corner, and door panels have been installed, check for squareness by measuring diagonally from corner to corner and adjust if necessary. Check that walls are plumb with a 4' spirit level and adjust if necessary.
6. The angle brackets on the interior of the door section must be secured to the floor after the door is plumb.



Warning! If the wall panels have not been properly leveled and squared, the top panels will not align and gapping or stair stepping will occur. This should be corrected before attempting to install the remaining top panels.

Wall Protector Plate (Wainscoting) Instructions

All Wall Protector Plate is cut to size and labeled in accordance to the drawing for easy installation.

1. Clean and dry wall surface
2. Follow the sequence of labels on the sheets of treadplate in accordance to the labeling on the drawing to layout the proper placement of treadplate.
3. Attach corner pieces, if applicable first, by applying to wall. Make sure the treadplate makes contact with the finished outside floor. Secure to wall using sheet metal screw every 24".
4. Attach each wall protector plate flush with one another. Make sure the treadplates make contact with the finished outside floor. Secure to wall using sheet metal screw every 24".
5. Caulk at all perimeter edges for proper finish.

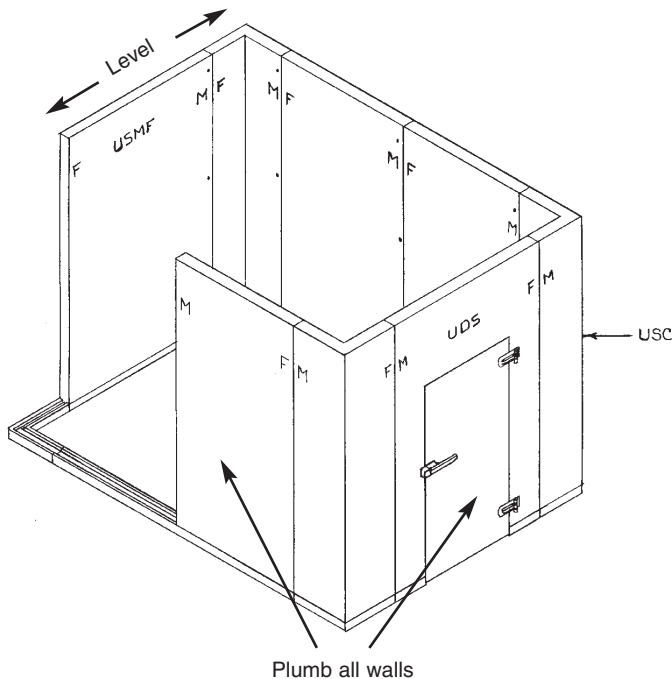

Figure #6

U = Urethane
 S = Side wall
 C = Corner
 M = Male
 F = Female
 D = Door

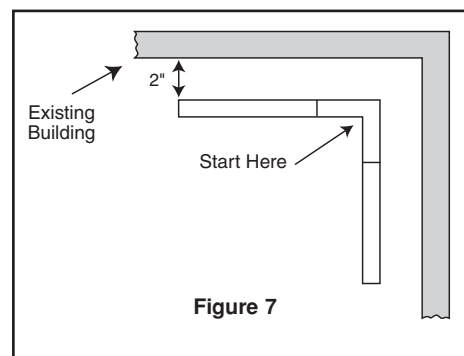

Figure 7

Top Panel Installation

Standard Walk-In: Begin installation of top panels at either end.

1. Check the drawing sent with the walk-in and assemble the top as indicated on this drawing. See Figure #8 for typical top layout.
2. Do not lock the top panels to the wall panels until all panels are positioned and aligned. If top is too large to shift (on larger boxes), go ahead and align, then lock.

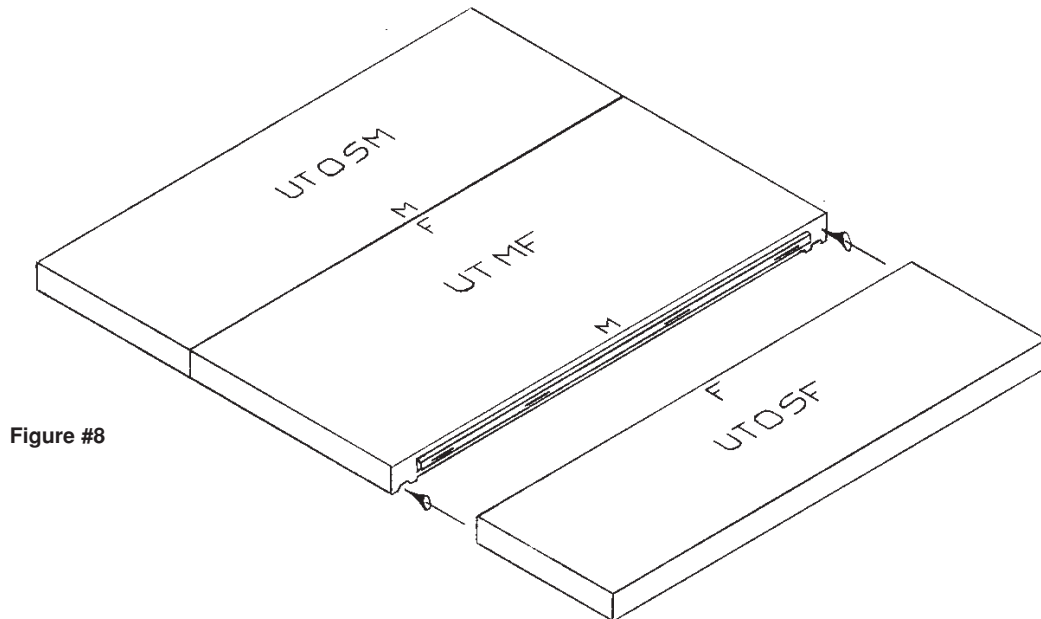
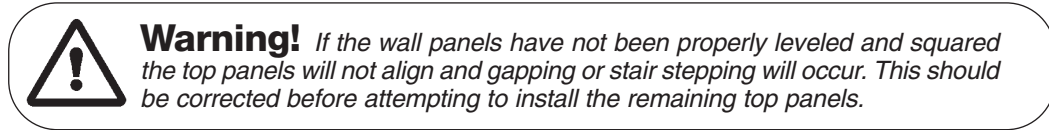

Figure #8

Multiple Compartment with a Partition Floor and Partition Top Panel Installation

1. Be sure the floor panels are installed with the male edge in the proper position.
2. Place the first "Tee" panel into position noting the position of the male edge. (Reference drawing)
3. Install the partition wall and lock into place. Make sure that all wall panels are even at the top.
4. Continue to install all wall and corner panels. Panels should be installed so that a corner panel is the last wall panel to be installed. Be sure to engage all cam locking devices in each wall panel.
5. After all wall, corner, and door panels have been installed, check for squareness by measuring diagonally from corner to corner and adjust if necessary. Check that walls are plumb with a 4' spirit level and adjust if necessary.

Multiple Compartment Walk-Ins With A "Tee" Panel

1. These walk-ins have a special divider for the top, floor, and wall panels. They must be placed in the proper location for the walk-in to assemble correctly.
2. Be sure the floor panels are installed with the male edge in the proper position (See Figure #9 for typical combination)

3. After the floor panels are installed and level, erect the partition wall panels.
4. After this the partition wall can be set in place and locked.
5. Position the remaining wall panels and lock them all down.
6. The top panels should be installed with the "Tee" Section first, then work toward the ends until all the tops are installed.
7. The combination walk-in must be level and square. Use the same methods as mentioned earlier in this manual. Refer to drawing supplied with order for proper placement of "Tee" panels.

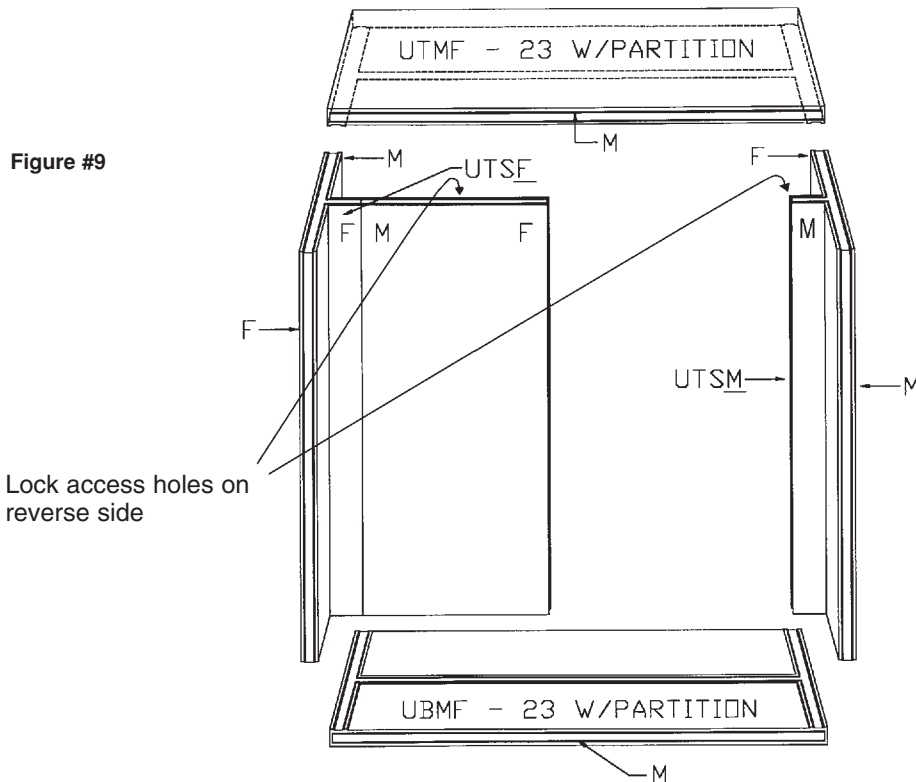

Penetrations of Panels

In some cases it will be necessary to make field penetrations through the walk-in for electrical and refrigeration lines. Some areas of the walk-in contain working parts and should not be penetrated. Refer to special panel details later in this manual under Door Section Cutaway and Door Heater Cable for any possible hazards.

Panels can be penetrated with a drill bit or with metal shears for holes too large to drill. Seal around all lines after installation. These penetrations must be sealed on the outside as well as the inside of the hole with silicon to prevent moisture entering the walk-in. Sealant not provided by W. A. Brown.

Membrane Roof Cap

Installation of Membrane Roof Cap (For Outside Units)

- Position single piece membrane over the walk-in allowing a 6" overhang on all four side without stretching the membrane.
- Allow membrane to relax for 1/2 hour prior to any splicing, cutting, or flashing.
- Beginning with the long side of the box at the center, layout the 2x6 flashing provided for that side. Start the first piece 2 1/2" from the corner. Apply hand pressure until the 2" top break is approximately 90 degrees. Install the #6 self tapping screws (provided) into sidewalls as shown. Working toward the corners, continue pressure to the top of the flashing. Flashing will come to within 2 1/2" of the corner, which will be covered by the corner piece provided. (See Figure #13)

- Repeat this procedure on all four sides.
- Trim extra material prior to sealing.
- Cut, fold, and glue roof membrane using contact cement (not provided)
- Position flashing to corner and form to fit by applying hand pressure to outside edges. Secure the corner flashing to the sidewalls.

Install to existing wall

- Allow membrane to extend up the existing wall approximately 6".
- Position 2 1/2" cove and fasten.

Apply contact cement or caulk (not provided by W. A. Brown) along the top joint where the cove joins the wall, down the edge at each end of the cove and down the edge of flashing at the wall.

Duro-Last® Roof Cap Installation (for outside installation)

The following are general instructions for installing the Duro-Last system. (See Figure #10)

- Surface Preparation: The Walk-In Top must be clean, smooth, free of sharp edges, loose debris and standing water.
- Placement: Select proper pre-manufactured and marked rolled sheet of Duro-Last membrane according to roof lay-out diagram. Orient roofing membrane so the 3" wide fastening tabs are perpendicular to Top Panel Joints. Secure to Walk-In through 3" fastening tab with approved fasteners and plates in accordance with specifications. Unfold Duro-Last membrane over tab. Continue unfolding until next 3" fastening tab appears. Repeat above procedure until entire sheet is fastened in place. Make sure to have 6" overhang on each side before starting fastening.
- Protusions: During the aforementioned procedure, make cutouts in the Duro-Last membrane for protusions. Fasten around cutouts with Duro-Last approved fasteners. The skirts on the factory fabricated accessories, when welded to the deck membrane, will cover these cutouts.
- Breather Vents: For every 1,000 square feet of deck membrane install a Duro-Last two way vent. Install vents according to Duro-Last specifications.
- Parapet Walls: Use custom fabricated parapet wall flashing designed specifically for each individual application and roof. Secure through 3" fastening tab at bottom of parapet wall using approved Duro-Last fasteners and plates, thus holding down edge of deck membrane. The dielectrically welded skirt will cover these and is then welded to the deck membrane.

Install 2 x 6 flashing as noted on page 7.

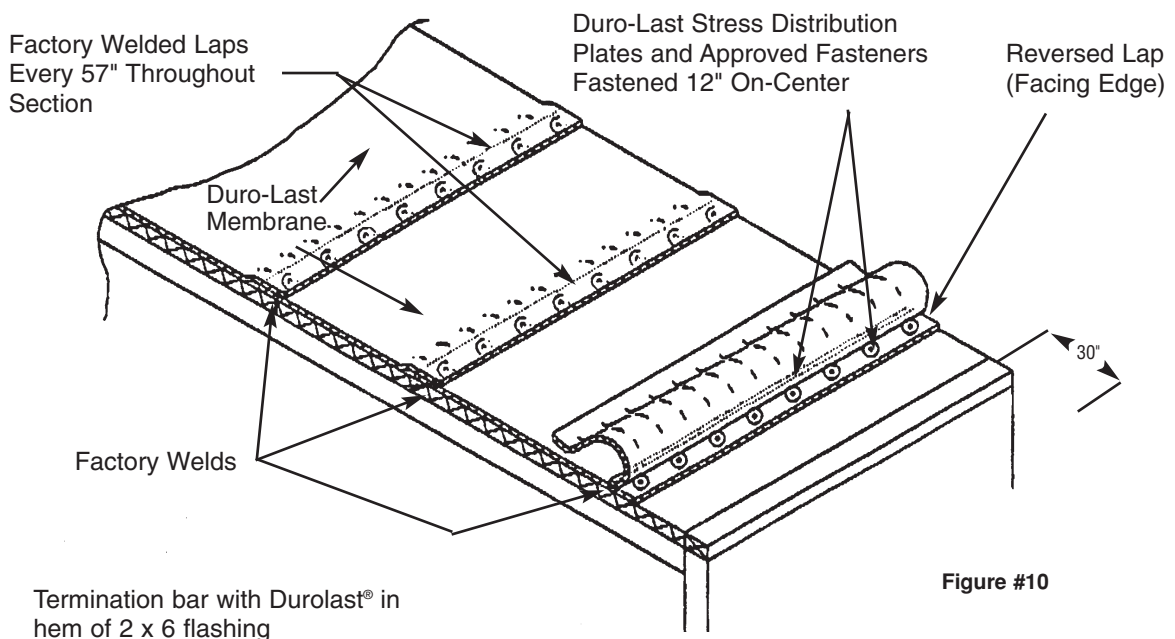

Figure #10

Fiber Cement Finish Panels Installation

Fiber Cement panels are available in vertical siding and smooth styles. Smooth Fiber Cement is designed to have a Stucco finish applied in the field or to be painted. Vertical siding style is meant to be field painted to more closely match existing construction. See instructions below on painting Fiber Cement.

Inspect all panels as outlined on page 1. All door sections and Buck Openings on Fiber Cement Walk-Ins are constructed using W.A. Brown traditional metal finishes.

Set out panels as outlined on page 1. Fiber Cement panels have a gasket on one side (the inside) and require caulking at the joint between the outside skins. Use only the approved ChemCaulk 2000 sealant manufactured by Bostik to seal these joints. This construction grade sealant is specifically designed for fiber cement and Hardie Board materials. If the **include caulk** option was chosen at the time of quotation and purchase, ample material will be supplied with the shipment. If not, this material can be purchased locally.

Caulk all wall to wall, wall to ceiling and wall to floor or floor screed joints with a .25" or 1/4" bead of material before locking the panels together. This will assure a good seal. Complete this process with the installation of each panel. Only the exterior fiber cement skins need to be caulked. No caulking is required on the interior gasketed surfaces.

Painting Fiber Cement

Flashing for Fiber Cement coolers and freezers will be factory primed, and will require on site final painting. Door sections and the door leaf can be primed at the factory for an optional charge if noted at time of order entry.

If you have not ordered factory priming, it can be accomplished on site. Latex paint is suitable for Fiber Cement, however it may not adhere properly to certain vinyl trim pieces.

After your Fiber Cement Walk-In has been fully assembled, it will be necessary to apply a finished coat of paint to all exposed surfaces. It is recommended that primed siding must be painted within 180 days of installation. Apply a high-quality, 100% acrylic paint. Solid or semi-transparent stains should be used only on unprimed Fiber Cement. Never use oil-based paints on Fiber Cement. For further questions on priming and painting Fiber Cement, feel free to contact W. A. Brown, or call Duck Back, Woodperfect Fiber Cement Coating at 800-825-5382. Ask about their water based, alkaline resistant, acrylic Latex primer and paint.

Top Panel Installation

Indoor walk-ins with dimensions of more than 15' 5" in both length and width (Figure #11) must have some type support for ceiling panels. Exterior beams, interior beams or column supports can be used. In these cases, it is imperative to properly install the rod assembly provided to properly support the ceiling panels and keep them from sagging. Failure to do so may result in an unsatisfactory installation.

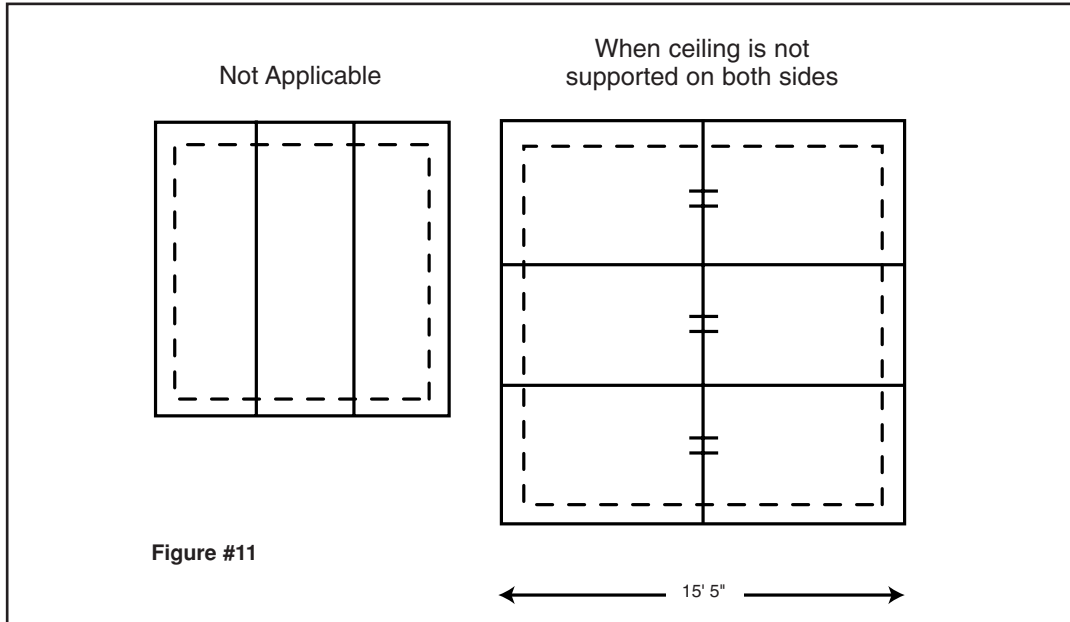

Warning! *Top design is for zero load. Warranty may be void if top is walked on, or other load is placed on top.*

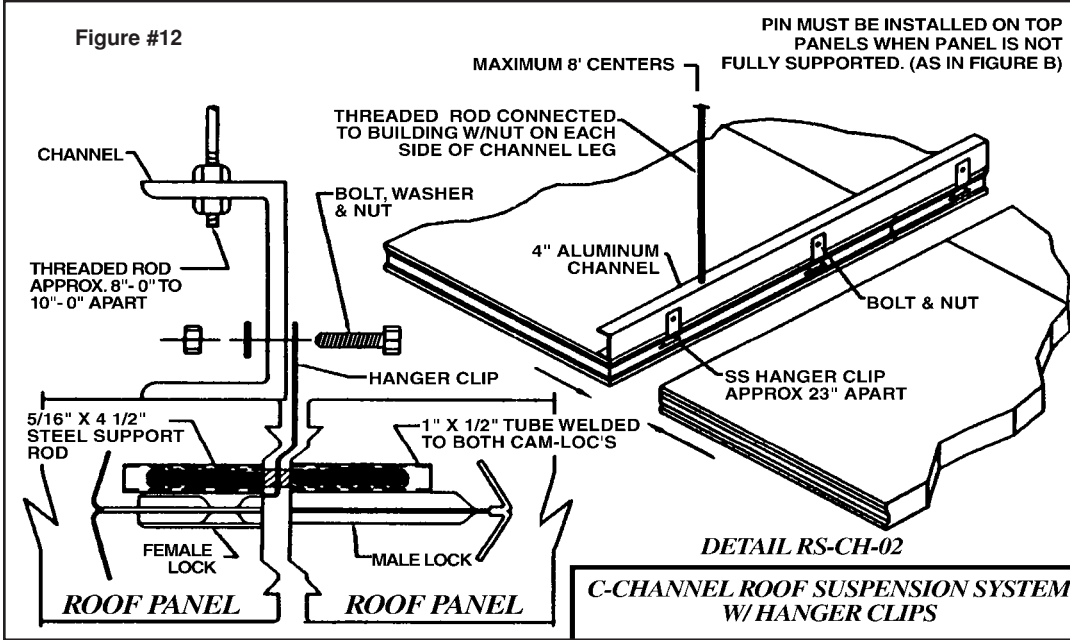

Top Panel Trim Installation

Installation of 1/2" x 5" Trim on Top Panels

- Trim is used to finish off all Walk-In Cooler and Freezers other than Drop-Off units and is left to the installer, as not all field conditions are identical. Trim is packed with each shipment (as required) from W. A. Brown.
- Install corner trim pieces first. Use four #6 self tapping screws supplied (See Figure 13-1). Install trim metal between corners. Overlap all joints by 1/2". Use one screw every 2' (See Figure 13-2). Caulk bottom of trim as needed. An inverted corner will not use corner trim pieces. Full length pieces are to be butted together in the corner (See Figure 13-3)

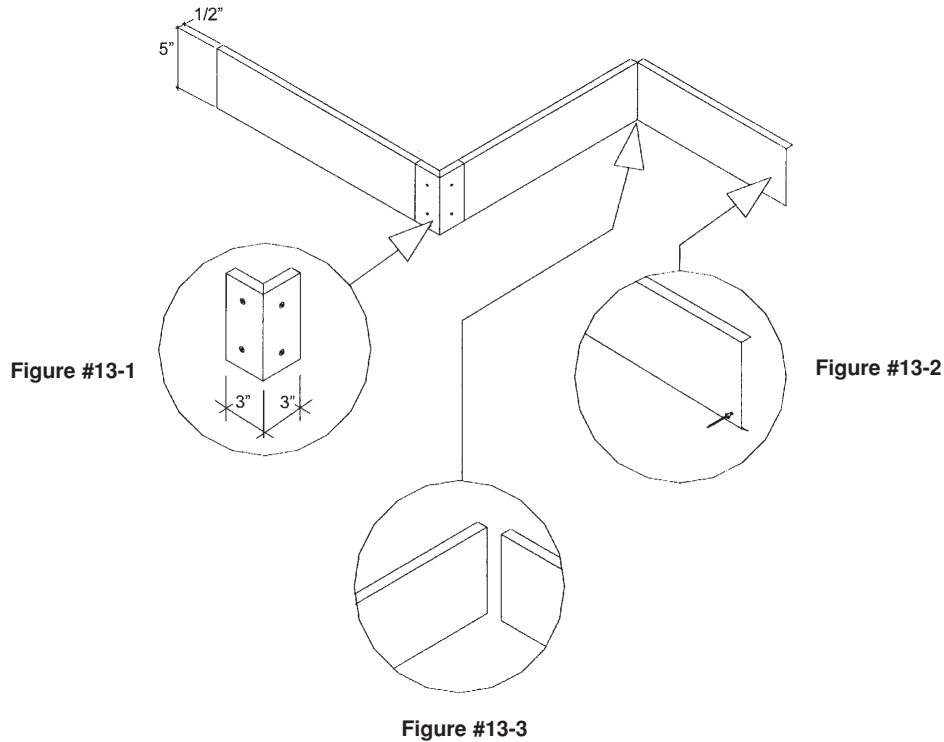

Drop-Off Walk-In Coolers and Freezers

Prior to the arrival of your Drop-Off Walk-In, you are responsible for assuring that the concrete slab is the appropriate size, thickness and level. Remember that the Drop-Off unit comes on metal runners which will affect the height of the floor.

Upon arrival, visually inspect the Walk-In for dents, scratches and other issues.

Unload the Walk-In and position properly. Finish door and threshold trimming.

Final positioning of the Drop-Off unit is the responsibility of the end user or general contractor.

Make final electrical connections in accordance to prevailing codes and start the cool down process.



Warning! *The electricity should not be turned on any door with a heater until the refrigeration system has been activated, as a failed heater wire may result. Do not operate Light with globe unless unit is cooled down. Maximum bulb size is 100 watts*

EZ Pack Installation Instructions

(See Installation Guide taped to top of each unit.)

Installing the Refrigeration System

A qualified technician should install the refrigeration. Contact the dealer from who you purchased your Walk-In for a qualified technician.

Carefully raise refrigeration system to top of walk-in. Insert projecting sleeve of evaporator box in to cut out of panel. Install louvered grill on interior side of top panel. Grill should be installed with fan motors.

NOTE: On smaller systems unit can be installed on top panel before panel is installed on walk-in.



Warning! *Never run system on an extended drop cord.*

Allow sufficient airflow around the condenser. A minimum of 2-foot clearance is required for proper operation. If more than one unit is located in the same area, do not exhaust hot air into other units. Indoor EZ Pack systems do not require drains.

Airflow should always be directed towards door section.

Setting Controls:

On walk-in coolers, the thermostat is factory set at + 35 degrees. Walk-in freezers are set at minus 10 degrees. Step-in freezers are set at 0 degrees. Adjustments can be made at control on thermostat located in evaporator box. On walk-in freezers a defrost timer will have to be set to time of day. Defrost timer is located within condenser housing. Refer to Heatcraft Installation Guide for "Pro" Series.

For Electrical Table, Refer to page 5, Heatcraft Installation Guide.

Final Checks Before Operation

1. If the door has a threshold plate, secure it to the floor with the screws that are provided. These screws are supplied by W. A. Brown and are taped to the door handle.
2. Check the door for alignment and proper operation. Check tightness of the door when it is shut. The use of magnetic gaskets eliminates the need for the positive style door latch to be snug. A little play is acceptable.
3. Check the door for proper seal. If the door does not close and seal properly, check that the door section is plumb with a spirit level and adjust as necessary.
4. When a floor spline is used, secure the door angles to the building floor. We recommend you use expansion bolts or a ram set type gun. Door must be plumb.
5. On door sections that do not have a threshold, it will be necessary to fasten spline covers at the bottom of the door. These covers are fastened to a wood shipping bar used to space the opening at the bottom of the door section.
6. Adjust the drag gasket on the bottom of the door. It should drag lightly on the threshold plate or floor to allow for pressure relief.
7. Secure thermometer bulb if it is not a model secured at the factory.
8. Insert the metal plug buttons into the lock wrench holes in all panels.
9. Check that all penetrations have been sealed. These penetrations must be sealed on the outside as well as the inside of the hole with silicon to prevent moisture entering the walk-in. (Sealant not provided by W. A. Brown.)



Warning! *The electricity should not be turned on any door with a heater until the refrigeration system has been activated, as a failed heater wire may result.*

Roof Cap & Curb Installation (Figure #14)

1. Make sure Walk-in top is completely clean of any debris.
2. Run bead of Silicone around cut-out opening.
3. Install 2 piece Wood Curb (provided) onto Walk-in top with counter sink screws (provided).
4. Follow procedures for installing Membrane Roof Cap over Wood curb, page 7.
5. Cut rubber roof cap over opening in X shape.
6. Roll rubber roof cap inside opening.
7. Run bead of Silicone around cut-out opening.
8. Set refrigeration unit in place.
9. Install protruding sleeve of unit into cut out opening of walk-in.
10. Screw unit base handles down with rubber grommet screws.
11. Install 3/4" PVC drain line with armor flex insulation over copper drain line. (Optional)
12. Install clamps over drain line on side of walk-in.
13. Run bead of silicone around unit base, rubber grommet screws and drain line.

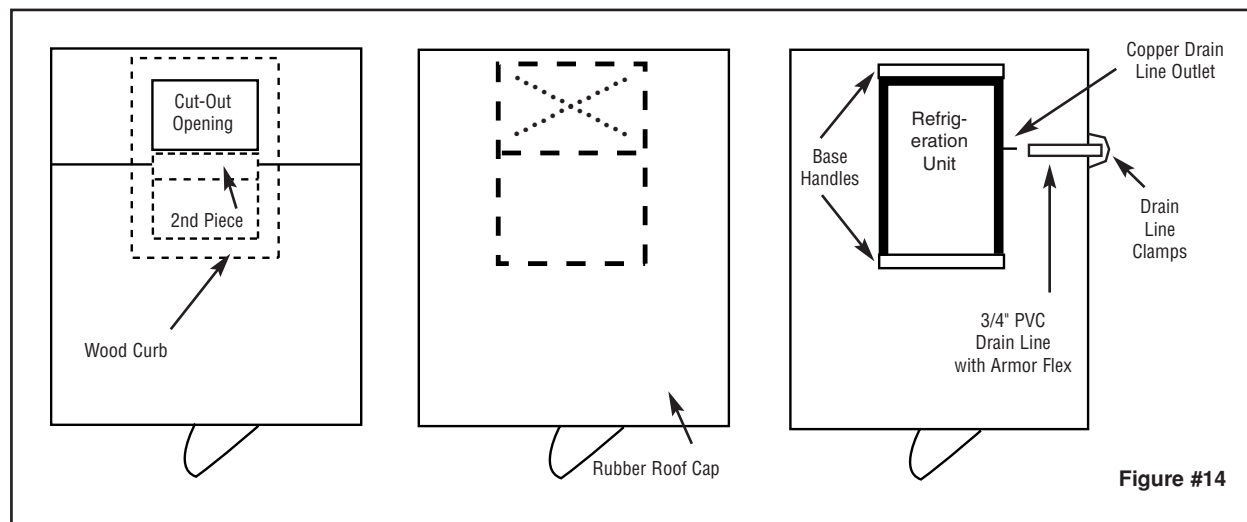

Warning! *Never penetrate rubber roof cap, (with exception of rubber grommet unit mounting screws.)*

Wiring the Door Heater, Lights & Windows

All freezers and some coolers are shipped with a 120V peripheral heater around the door to eliminate condensate and keep the door frame and jamb from “sweating”. Likewise most freezer windows are also designed with a 120V heater for the same reason.

Vapor Proof Light

This light is internally wired to the light switch. Only source power needs to be wired into the junction box powering the light. Maximum bulb size is 100 watts. Do not operate with globe until walk-in is at operating temperature.

Fluorescent Lights

These lights are field installed and will require both source power and internal wiring by a qualified electrician. The above will be wired to door switch via “J” Box on interior of door section in most cases.

All installation should be in accordance with NSF and prevailing electrical code.



Warning! *When installing your Walk-in cooler or freezer, always use a qualified electrician for all your wiring needs. Refer to wiring diagram included in this manual.*

Housekeeping and Safety

Housekeeping and Safety Recommendations

Please use caution when inside any walk-in. The floor may become slippery if allowed to become wet or greasy. To provide user safety, to maintain optimum performance and long life of this product, we recommend regularly reviewing the following procedures with anyone that may enter the walk-in:

- Keep all walkway surfaces clean and free of spilled liquids and food particles. All aisles must be kept clear for passage.
- Inspect the condition of the anti-skid strips monthly. Replace or add additional strips as needed.
- Keep door closed to prevent the accumulation of condensation on floor and other surfaces.
- Inspect refrigeration equipment frequently for proper functioning of evaporator drain pans, defrost controls and drain line heaters.
- Condensate water must never be allowed to drip on the walk-in floor. Refer to the refrigeration instructions for proper condensate line installation.
- Frost or condensation appearing around the door jamb indicates that the heater cable is inoperative or that the door gasket may need to be replaced, or that the door has not been properly closed.
- Hinges used on the doors are self closing with a nylon cam and bushing. The hinges are lubricated at the factory for ease of operation. They should be lubricated every three months with petroleum jelly. Care should be used to keep dirt and trash out of the hinge.
- To help prevent moisture accumulating in the insulation, be sure to replace missing plug buttons. Additional buttons are shipped with each order.



Warning! *If you observe any abnormal or unsafe conditions, you should contact your maintenance manager to have this condition corrected.*

Cleaning of Stucco Aluminum & Galvalume Plus

The ceiling, walls and floors of Brown walk-ins are covered with a metal finish. Cleaning of this surface can be accomplished by the use of a mild detergent, warm water and a soft cleaning cloth.

The use of an abrasive type cleaner can scratch the surface of the metal. The use of any form of cleaning agent that contains any form of acid may cause a discoloring or darkening of the metal finishes. Markings made by felt tip pens or "Magic Markers" can be removed by use of lacquer thinner, varsol, or naphtha. After using these cleaners, wash the space with soap and warm water to remove any chemical residue.

Cleaning Stainless Steel Finishes

1. Always clean in the direction of the grain.
2. Use alkaline, alkaline chlorinated or non-chloride containing cleaners. If you are unsure, check with your cleaner supplier.
3. Rinse, Rinse, Rinse.

Cleaning of Door Gaskets

Magnetic door gaskets should be cleaned with mild detergents and hot water. Remove all soap film and dry thoroughly with a clean cloth. Strong cleaners are corrosive and should not be allowed to come in contact. Never use acids (hydrochloric or muriatic for example) on door gaskets.

How To Call for Service Repair

After your W. A. Brown & Son, Inc. Walk-in has been correctly installed, and the refrigeration system properly connected your new Walk-in should provide you years of uninterrupted service. Should your Walk-In ever require service, please have the following information available upon initiating a service call.

Determine the date your walk-in was placed into service and enter it here. _____

Locate the serial number located on the door of your unit and enter it here. _____

Determine the dealer from whom you purchased your walk-in and enter it here. _____



Should you feel your Walk-in refrigeration system is not operating properly and your unit is covered under warranty, please contact W. A. Brown & Son, Inc. by calling 800-438-2316 and ask for Refrigeration Service. Provide the date your unit was installed for use and the serial number, along with the name of the dealer from which you purchased your unit. Describe the nature of the problem, and our qualified technicians will refer you to the appropriate trained servicer, or, you may use your preferred local refrigeration technician. See exact detail regarding labor warranty if you have purchased the optional one year labor warranty. Of course repairs that are covered under warranty will be handled at no charge to you. Expenses that result from calls not covered under warranty (such as fuses blown or a unit not plugged in) will be invoiced to the person asking for the service call.

Replacement Parts

For best operation, always use official replacement parts for items such as hinges, gaskets, and latches. These can be purchased directly from W. A. Brown by calling Service Parts at 800-640-0593 or visit us on the web at www.wabrown.com. Minimum orders and order handling charges may apply.

Replacement door latch keys are available at a minimum charge.

Data Plate - Located on inside of main door.

	W.A. BROWN & B SON, INC. Since 1910 Salisbury, NC	
REFRIGERATION REQUIREMENTS		
For Storage Temperature of 0 ° F		
○	Evaporator: 6578 BTU / HR at 10° TD	○
Condensing Unit: 6578 BTU / HR at -10 °		
Suction Temperature. in 100° Ambient		
	SERIAL NO. 98949-1D2 UL MODEL: UDS-4 SIZE: 9X13 04	
LISTED 480E DOOR PANEL ASSEMBLY 120 V. A. C. 300 WATTS		COMPONENT

Serial No. (5 digits w/dash for door number ex: 90117-1D2)
(This number is the same as the Order Number)

Size (Size of box and year mfg'd ex: 16X17-01)

UL Model (This number UDS-4 can not be used to identify order - it means there is 4" of urethane foamed in panels)

LIFETIME LIMITED CABINET WARRANTY

W. A. Brown & Son, Inc. warrants to the original purchaser, the full foamed-in-place aluminum and stainless steel panels manufactured and sold by it, to be free from defects in material and workmanship under normal use and service for life from the date of original installation by an authorized representative. All other panels manufactured by W. A. Brown & Son, Inc. shall be warranted against delaminating and/or insulation decay for life from the date of original installation by an authorized representative. Oxidation of panels other than aluminum and stainless steel is expressly excepted from this warranty. All door hardware shall be warranted for a period of five (5) years. W. A. Brown shall warrant all gaskets, and electrical components, which are reasonable and proper, for a period of one (1) year from the date of original installation. This warranty does not apply to equipment, which has been subjected to abuse, misuse, or acts of God and is exclusive of all freight and labor charges unless a labor warranty has been purchased.

ONE (1) YEAR LIMITED REFRIGERATION SYSTEM PARTS WARRANTY

W. A. Brown & Son, Inc. warrants to the original purchaser all parts of the refrigeration system for a period of one (1) year commencing forty-five (45) days after shipment from the W. A. Brown & Son, Inc. factory..

W. A. Brown & Son, Inc. shall be liable for the wholesale cost of these parts. This warranty shall not apply to the refrigerant gas loss from the refrigeration system. W. A. Brown & Son, Inc. deems a refrigerant gas loss warranty, if any, to be the responsibility of the installing dealer or contractor.

ONE (1) YEAR LIMITED REFRIGERATION LABOR WARRANTY

W. A. Brown & Son, Inc. warrants to the original end user the labor for service work on the refrigeration systems for a period of one (1) year commencing forty-five (45) days after shipment from the W. A. Brown & Son, Inc. factory.

This warranty when purchased as an optional item at the time of the original equipment purchase will cover reasonable and proper labor charges in the repair of the refrigeration system.

The refrigerant gas is also covered under this warranty, but shall be limited to the wholesale cost, plus up to a 100% mark-up. The amount of refrigerant is limited to an amount which is ten (10%) percent above maximum pump down capacities. W. A. Brown & Son, Inc. will furnish a list of these capacities to the end user upon request.

This warranty does not apply to drains, drain heaters, electrical circuits which are external to the refrigeration equipment, fuses, adjustments to temperature controls, pressure controls or time clocks.

This warranty does not cover travel time, truck charges, mileage charges, or waiting time.

It is the responsibility of the end user to select or contract the service company to effect the above mentioned repairs. However, W. A. Brown & Son, Inc. retains the right to approve or disapprove any refrigeration service company at its sole discretion.

FOUR (4) YEAR LIMITED CONDENSING UNIT COMPRESSOR WARRANTY

W. A. Brown & Son, Inc. warrants the condensing unit compressor only for four (4) years parts warranty if purchased with at the time of initial order. W. A. Brown & Son, Inc. warrants this compressor to be free from defects in material and workmanship under normal use and service. W. A. Brown & Son, Inc. obligation shall be limited to repairing or replacing the compressor, which proves to be defective upon purchase. This warranty shall not apply to any refrigerant gas loss from the refrigeration system. W. A. Brown & Son, Inc. deems a refrigerant gas loss warranty, if any, to be the responsibility of the installing dealer or contractor.

THE FOREGOING WARRANTIES ARE EXPRESSLY IN LIEU OF ALL OTHER WARRANTIES, EXPRESSED OR IMPLIED AND THERE ARE NO WARRANTIES WHICH EXTEND BEYOND THE DESCRIPTION SET FORTH ABOVE. W. A. Brown & Son, Inc. NEITHER ASSUMES NOR AUTHORIZES ANY OTHER PERSON TO ASSUME FOR IT ANY OTHER OBLIGATIONS OR LIABILITIES IN CONNECTION WITH THE SALE OF ITS WALK-IN COOLER OR FREEZER CABINETS, REFRIGERATION SYSTEM, CONDENSING UNIT COMPRESSOR OR ANY PART OF PARTS THEREOF. W. A. Brown & Son, Inc. shall not be responsible for damage caused in transit, alterations by unauthorized service, negligence, abuse, misuse, damage by war, flood, fire or acts of God.

W. A. Brown & Son, Inc. shall not be responsible for any food spoilage, product loss, transportation charges, labor or other costs in the replacement of any part or parts, or consequential damages of any kind, and the obligation to repair or replace as stated in the applicable warranty or warranties states the entire liability of W. A. Brown & Son, Inc. whether based on tort, contract, warranty or implied warranty. Any and all parts replaced under any of all of the above warranties shall be F. O. B. Salisbury, North Carolina, and the maximum liability by W. A. Brown & Son, Inc., shall be the wholesale value of said part or parts only.

The warranties herein stated shall not be assignable and shall be operative only in favor of the original purchaser-user.

Instructions for removing Door Leaf with Spring Loaded Hinges (See Figure #15)

1. Open Door to dwell position, stopping at approx. 120°.
2. Put mark on floor to indicate position of Door.
See sketch.
3. Lift Door off frame.
4. To replace Door, line up Door with mark on the floor.
5. Place Hex Hole in hinge straps over Hex Rods and lower Door.

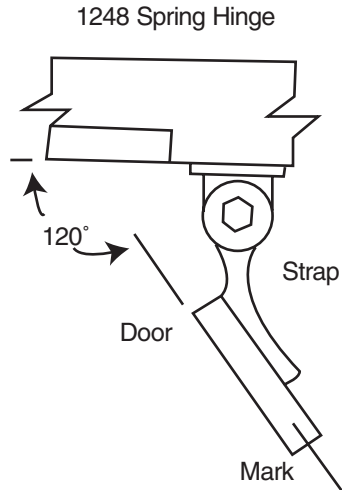

Figure #15

Instructions for Door Hinge Pin replacement, (See Figure #16)

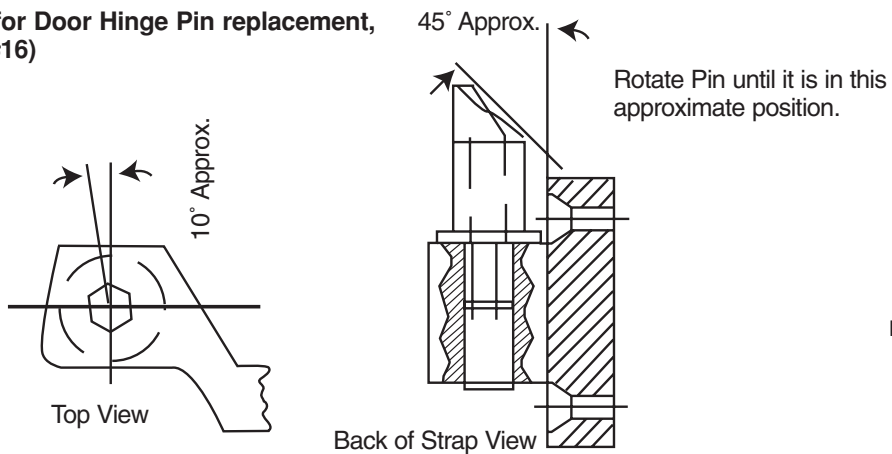

Figure #16

*For Offset Hinge, Pin is rotated 180 Degrees

Adjusting Door Closer (See Figure #17)

For proper operation with roller in down position, adjust hook to 1/32" above roller.

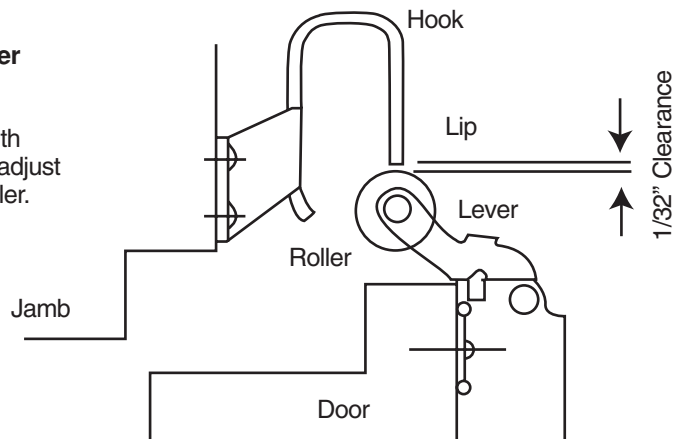

Figure #17



Warning! Door Closure lever must remain horizontal when door is open.

Description Of Numbered Door Section Components

1. Vapor Proof Light (use standard light bulb, maximum 100 watts) with plastic coated glass
2. Electrical Junction Box
3. Door Closer
4. Temperature Indicating Device (Dial Shown)
5. Light Switch With Neon Pilot Light
6. Door Latch Assembly
7. Heater Cable
8. Door Hinge
9. Threshold Plate
10. Drag Gasket
11. Floor Panel

All wiring contained within the door section is 115/60/1 with the exception of the digital thermometer when used. The wiring from the low voltage side of the class 2 transformer is 12 volts. Wiring from the line side of the transformer 115/60/1 phase. Door Sections are UL Approved.

DOOR SECTION CUT AWAY

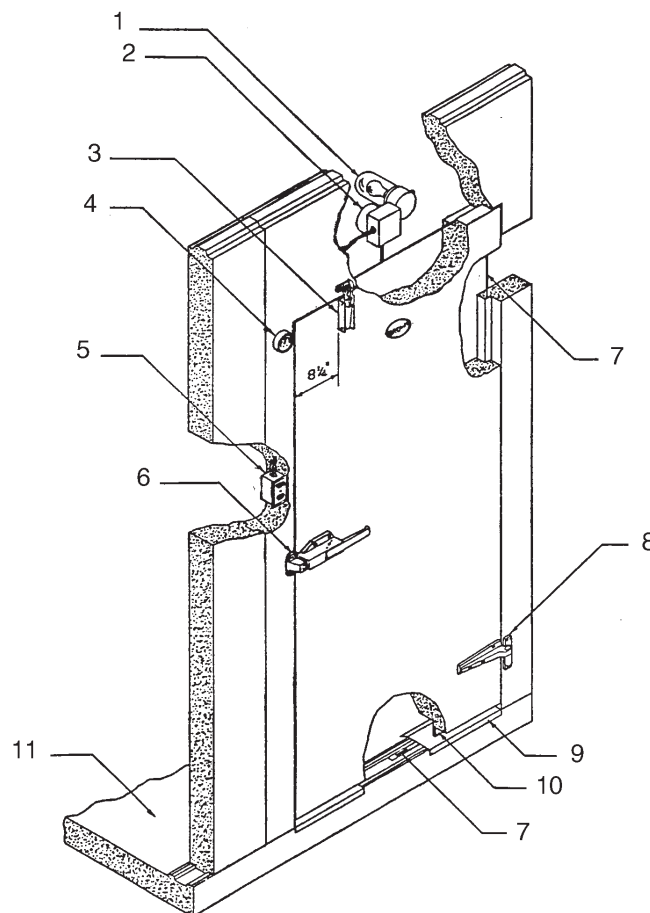

Figure #18

Replacement Keys

Should replacement keys be required, call our Customer Service Department with your serial number (see page 15) They will be able to provide extra keys at an additional charge.



Warning! Do not leave light on or have heater cable activated for extended periods of time when Walk-in is not in operation.

Guidelines For Replacing Door Heater Cable

If door jamb is sweating or icing, you need to use the following guidelines.

1. Check the circuit breaker to see if it is in the on position and functioning properly.
2. Check the heater cable (#1) for current at the junction box.
3. Turn the circuit breaker off that supplies electricity to the heater cable
4. Check the heater cable for continuity. If the circuit is open you will need to replace the heater cable.
5. Remove the screws (#10) from the threshold plate (#6) but DO NOT remove the threshold at this time.
6. Remove the screws (#7) from the stainless steel jamb/heater cover (#3).
7. Remove the stainless steel jamb/heater cover (#3).
8. Remove the threshold (#6) and peel the tape off the cover channel (#9) to the bottom of the threshold.
9. Tape the heater cable in the groove around the door jamb, and run the leads in to junction box.
10. Replace the stainless steel heater covers (#3) and the threshold plate (#6). Install all screws securely.
11. Connect the electricity and turn on the circuit breaker.
12. Allow 15 minutes for the heater to warm up, feel to see if it has warmed the threshold (#6) and the heater covers (#3).

Description Of Numbered Parts in Figure #19 and #20

- | | |
|---|--|
| <ol style="list-style-type: none"> 1. Heater Cable 2. Fiberglass reinforced plastic 3. Magnetic stainless steel heater cover 4. Interior/Exterior metal finish 5. Floor section (may not be on all walk-ins) | <ol style="list-style-type: none"> 6. Stainless steel threshold plate 7. Stainless steel screws 8. 4 inch Urethane insulation 9. Channel cover 10. Stainless steel screws |
|---|--|

Figure #19

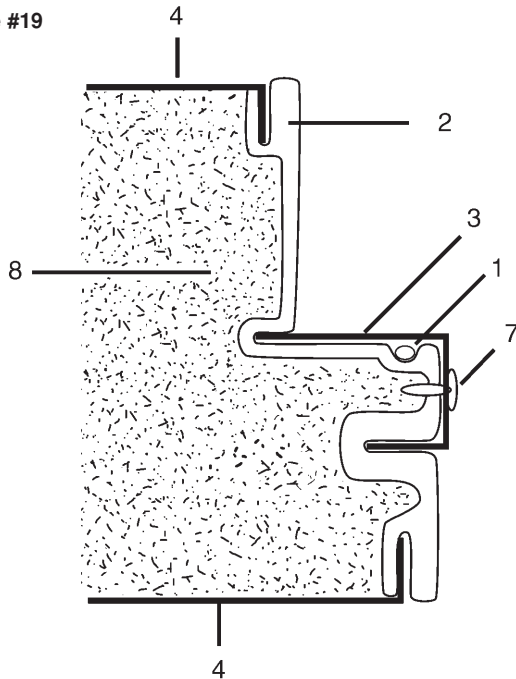
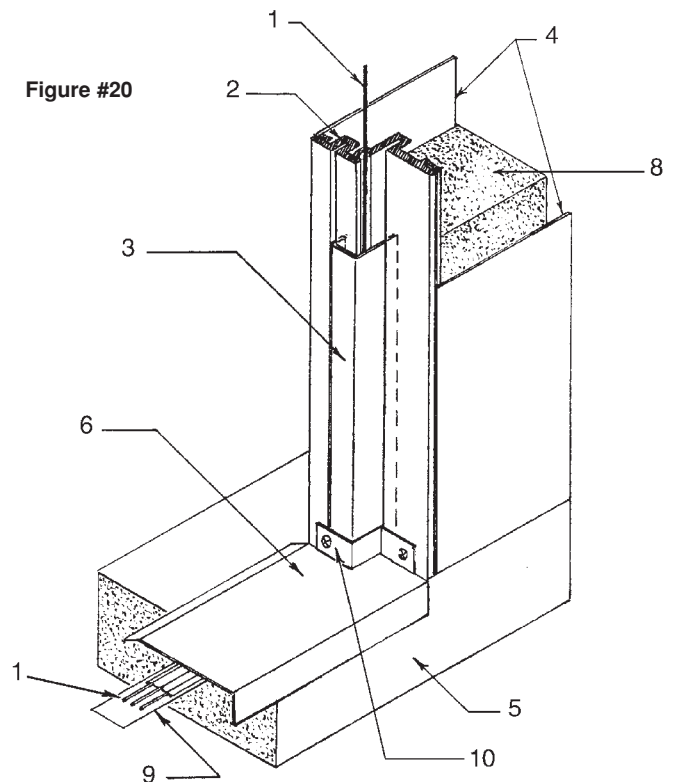

Figure #20



Relacing Door Gasket

1. Open the door to a 90° angle. Using two people, lift the door leaf from the hinges and place it horizontally across two saw bucks or similar supports. (CAUTION: When removing door leaf from door section use caution not to dislodge the hinge pins.) See page 17 if this occurs.
2. Start at the bottom of the door removing the old gasket. Remove it by pulling it from the groove.
3. Lay the new gasket on the door leaf. Begin by pushing the corners in place.
4. Push the gasket into the door along the top, working from each corner toward the middle.
5. Start at the top of the door and work toward the bottom, pressing the gasket into the groove.
6. The gasket will be longer than the door leaf. Take a pair of scissors and cut the gasket off to match the length of the door leaf.
7. Slide the magnet out of the gasket and cut 1/2" to 3/4" off the magnet.
8. Push the magnet in place. Check the top corner to make sure that the gasket meets at the top.
9. Place the vinyl plug in the bottom of the gasket and glue, heat seal, or staple in place. This is to prevent the magnet from falling out.
10. Using two people, place the door back on its hinges.
11. Check the door for proper seal on all sides.

Cross Section Of Door Leaf

Description Of Numbered Parts in Figure #21

1. Magnetic door gasket (NSF approved grey)
2. PVC Door perimeter (NSF approved grey)
3. 4" Urethane foam
4. Metal finish

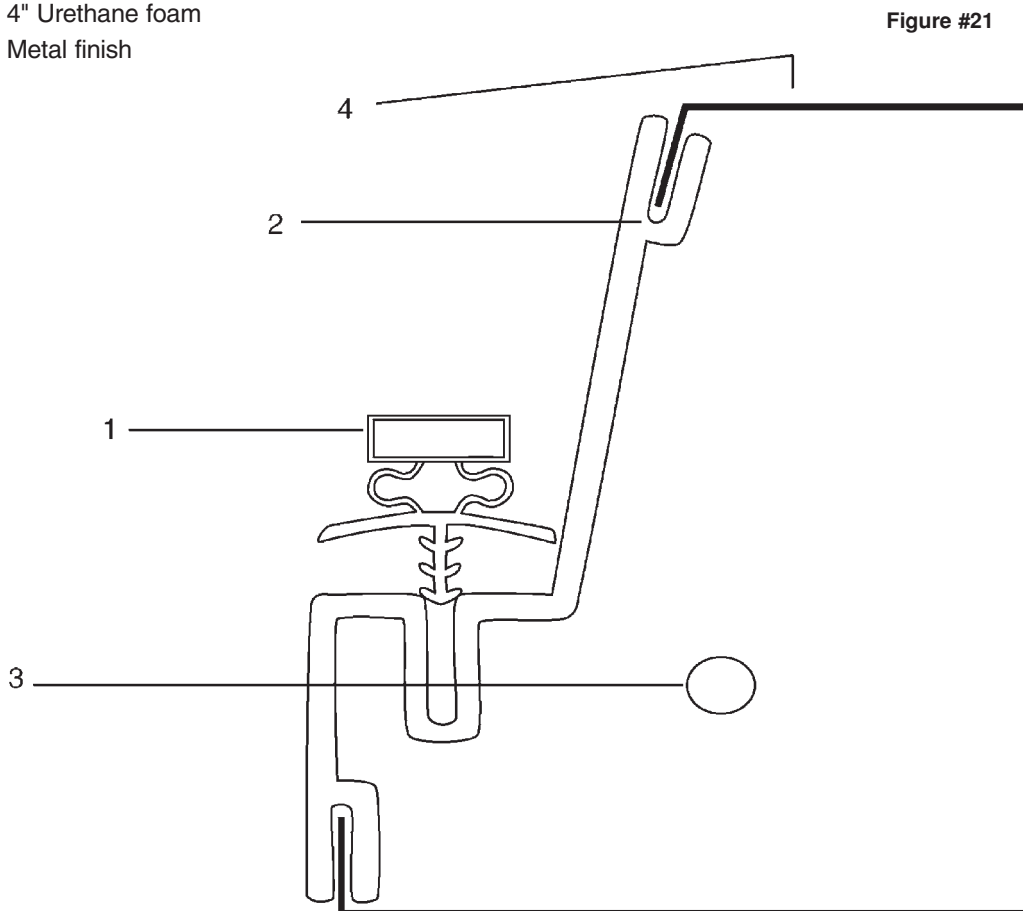

Replacing Flush Dial Thermometer

Dial Thermometer: Complete Field Replacement - Flush Mount in Figure #22

Locate thermometer to be replaced. From inside of box, cut wire tie holding bulb. Remove screws from flange face with screw driver. Work flange free from section. A putty knife works well for this purpose. Applying uniform pressure, pull bulb through section. Clean residual silicone from section.

Retrieve new thermometer, and unwrap. Using old thermometer as reference, re-wrap new thermometer tubing in similar manner as old thermometer. Apply a small amount of silicone (not provided) to section around cutout, and insert thermometer bulb first. Visually center thermometer face and insert screws (holes should align).

Place bulb on cradle and new wire tie wrap, and secure. Trim excess tie and apply silicone to hole in section. After five to ten minutes check thermometer set point to known standard. If adjustment is needed follow instructions to reset pointer.

Figure #22



Installing Surface Dial Thermometer (Figure #23)

Dial Thermometer: Complete Field Installation - Surface Mount

To locate position of thermometer, for standard placement in leg of Door Section, look at leg that has the light switch mounted in it. Measure from the center of the switch up 15 1/2" on center with switch and mark. Installation onto other panels must be clear of locking devices and any other special applications.

Center punch so that the Drill Motor will not lead off as the hole is produced. Using a 7/16" diameter drill bit, produce a through hole. Using a 7/8" diameter drill bit, enlarge the outside 7/16" hole to a depth of approximately 1". Clean loose foam and debris from area.

Retrieve the thermometer and carefully straighten the bulb tubing. Place the bulb through the 7/16" hole towards inside of box. Place a small bead of silicone caulking (not provided) around the 7/8" hole (to act as a seal). Position body of thermometer over 7/8" hole, and rotate to center face visually. Secure screws and fasten flange to outside of section.

Inside the box, locate the bulb in the position for installation, keep in mind amount of traffic and storage in box). Position the plastic cradle where you wish bulb to be, and secure to the skin with the screw. Run a wire tie wrap around cradle so that the bulb can be secured, trim tie and fill 7/16" hole with silicone.

After the Thermometer has been in operation for five to ten minutes, secure a known reference for which to check the set point of the thermometer installed. If adjustment is needed, follow instructions to reset the pointer.

Figure #23



Replacing The Digital Thermometer

Turn off breaker before disconnecting wires.

If the thermometer does not register correctly you will need to check the following:

1. Check the voltage on the load side of the transformer. It should be 12 volts.
2. If the voltage is not 12 volts on the load side of the transformer, check the line side to confirm that proper voltage is reaching the transformer.
3. If you have 115 volts on the line side and nothing on the load side you will need to change the transformer.
4. If the transformer checks good you will need to change the digital display. This is done by removing the two screws from the front of the display and pulling out the whole module. Take the two wire nuts off the incoming power located behind the display. Pull the probe out through the insulated section. Push the new probe through the same hole in the insulated section and secure. Hook the two wires back to the incoming power from the transformer. Replace the display on the door section and secure with the screws. Turn the power on and check the display.

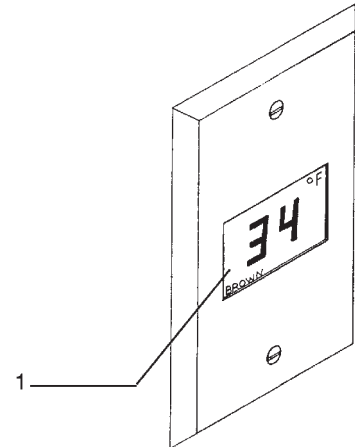

Figure #25

Description Of Numbered Parts, Figure #24 and #25

1. Junction Box
2. Optional wire guard for vapor proof light
3. Plastic coated glass globe for vapor proof light

Replacing A Pressure Relief Port

After determining the pressure relief port is defective use the following guidelines:
(NOTE: THE HEATER IS NOT AVAILABLE SEPARATELY.)

1. Turn off the electrical supply to the pressure relief port.
2. Remove the inside and outside louvers and remove any sealant that might be holding the port in place.
3. Open square J. Box and disconnect two small white wires and one green wire to PRP.
4. Pull out the PVC portion of the port along with the wiring.
5. Feed the wire from the new port through the hole up to the junction box.
6. Put the PVC portion back into the wall section making sure that the heater is in the interior of the walk-in.
7. Seal around the interior with silicone (not provided) then install the interior louvered flange.
8. Push the vent in tight against the interior flange.
9. Seal around the exterior PVC portion with silicone (not provided) and install the exterior louver.
10. Connect the electrical wires and turn the electricity on.
11. After 15 minutes check to see if the heater is working on the new port.

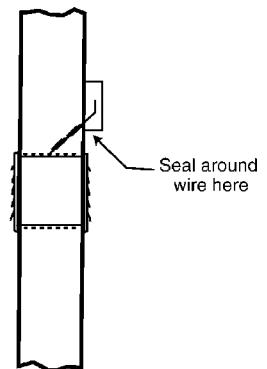

Figure #27

2 1/2"
Pressure Relief Port

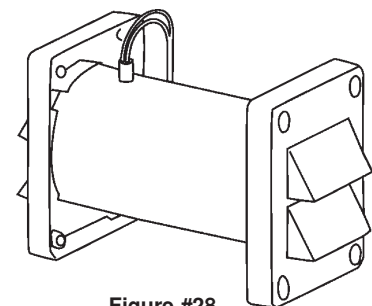

Figure #28

Description Of Numbered Parts, Figure #27, and #28

1. 4" Urethane wall
2. 45 degree 1/2" hole
3. 1/2" groove to hole
4. Wire
5. Junction Box at header of door
6. 2 1/2" hole

Electrical Hook-Up to Junction Box

1. Connect incoming conduit to 3/4 diameter hole on right side of junction box.
2. Selection of conduit type, connection method and wire type in accordance with local codes. Responsibility of installing contractor.
3. Once 120 volt power is pulled to the junction box, insert a sharp pointed tool into the box marked ①. Apply pressure downward to open the wire termination opening in the box marked "Black". Insert Black wire and release tool. The spring loaded insert should now have a tight connection on the wire. If the wire pulls out, repeat procedure until the wire will not pull out under hand pulled pressure.
4. Repeat step 3 except for box marked ② and "White" wire location.
5. Land ground wire on either the post on the lid or within the junction box.
6. Make final check before energizing panel and securing the junction box lid.

Electrical Hook-Up to Junction Box

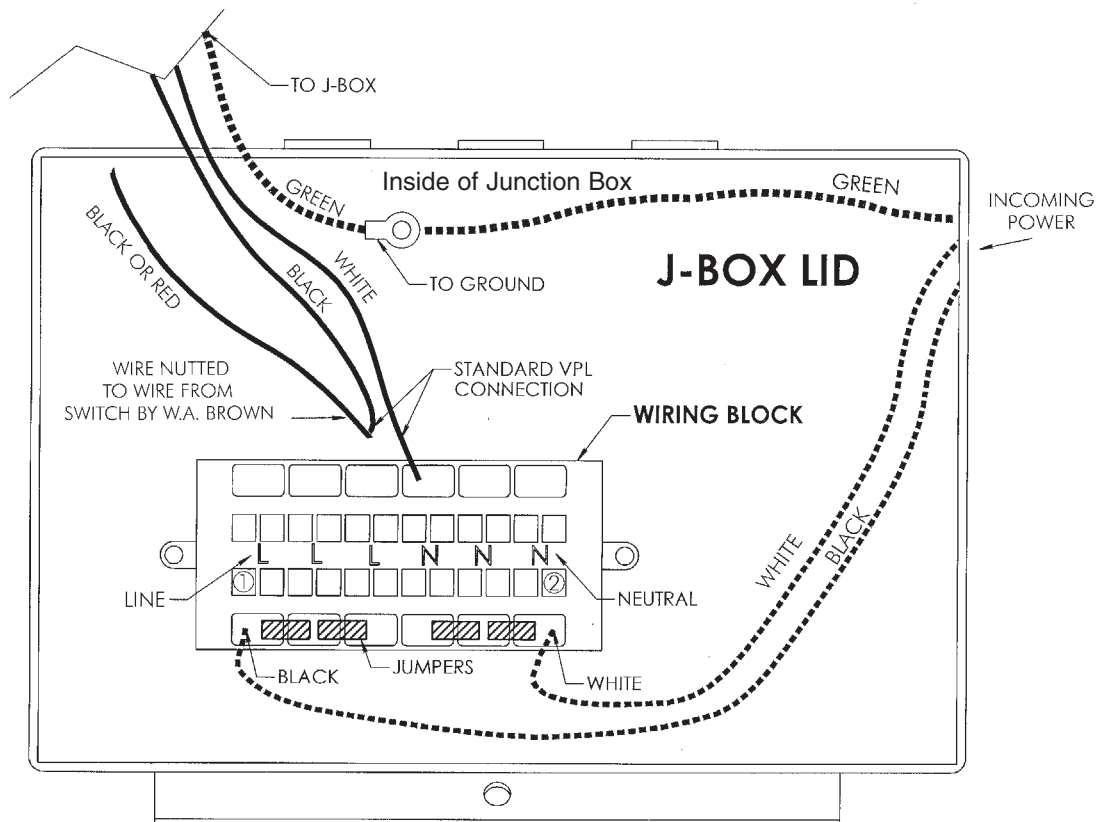

Figure #26

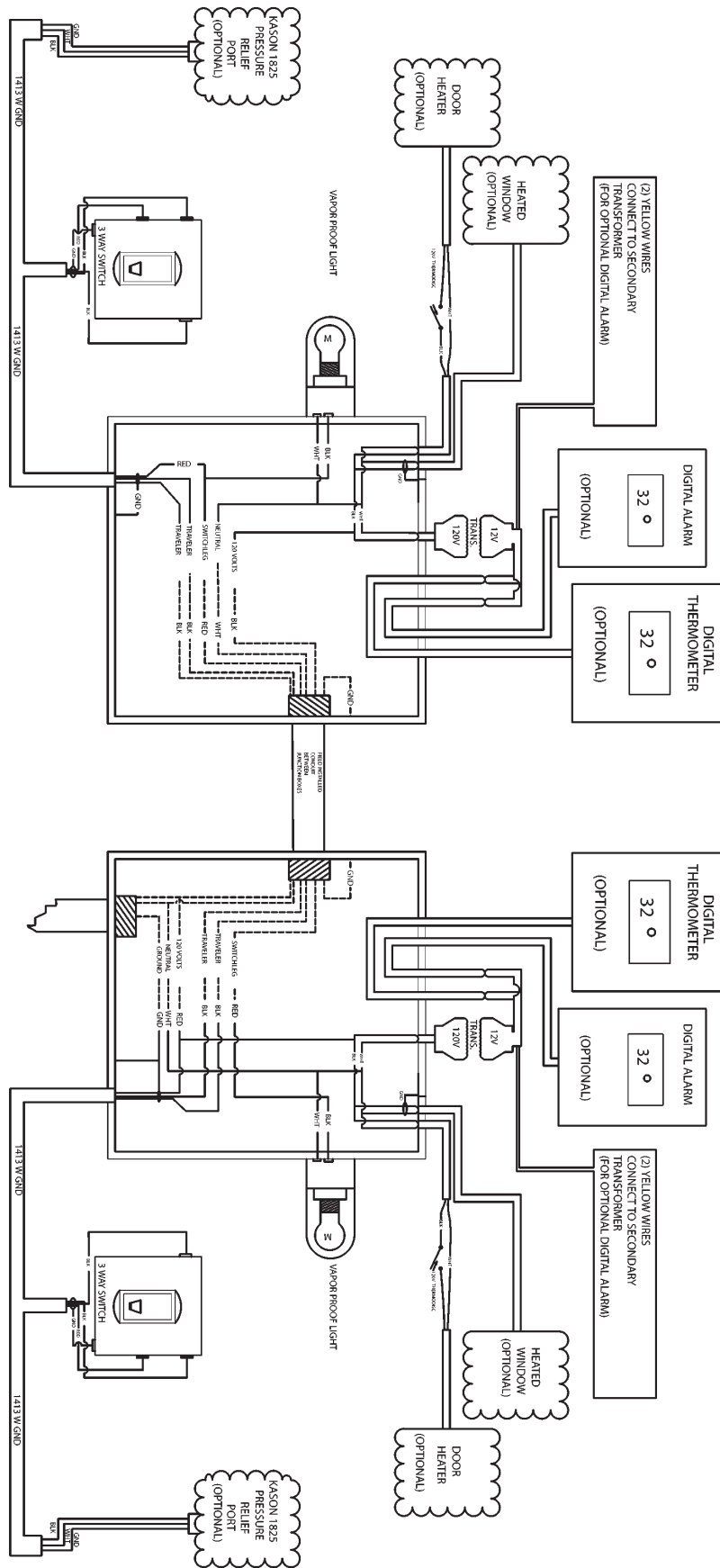

Figure #30

Refrigeration Trouble Shooting Guide

Always use a certified trained Refrigeration Technician when repair of your refrigeration system is required.

Malfunction	Possible Cause	Solution
Compressor will not start - no hum	Service cord unplugged Fuse blown or removed Overload tripped Control stuck open Wiring incorrect	Plug in service cord Replace fuse Determine reasons and correct Repair or replace Check wiring against diagram
Compressor will not start - hums but trips on overload protector	Improperly wired Low voltage to unit Starting capacitor defective Relay failing to close	Check wiring against the diagram Determine reason and correct Determine reason and replace Determine reason, correct or replace
Compressor starts & runs, but short cycles on overload protector	Low voltage to unit Overload defective Excessive head pressure Compressor very hot-return hot gas	Determine reason and correct Check current, replace overload protector Check ventilation or restriction in system Check refrigerant charge, fix leak if req 'd
Compressor operates long or continuously	Short of refrigerant Control contact stuck Evaporator coil iced Restriction in refrigeration system Dirty condenser	Fix leak, add charge Repair or replace Determine cause, defrost manually Determine location & remove Clean condenser
Compressor runs fine, but short cycles	Overload protector Cold control Overcharge Air in system Undercharge	Check wiring diagram Differential too close-widen Reduce charge Recover and recharge Fix leak, add refrigerant
Starting capacitor open, shorted or blown	Relay contacts stuck Low voltage to unit Improper relay	Clean contacts or replace relay Determine reason and correct Replace
Relay defective or burned out	Incorrect relay Voltage too high or low	Check and replace Determine reason and correct
Refrigerated space too warm	Control setting too high Refrigerant overcharge Dirty condenser Evaporator coil iced	Reset control Recover refrigerant Clean condenser Determine reason and defrost
Standard temperature system freezes the product	Control setting is too low Control points stuck	Reset the control Replace the control
Objectionable noise	Fan blade hitting shroud Tube raffle Vibrating fan blade Condenser fan motor raffles General vibration Worn fan motor bearings	Reform/cut away small section of shroud Locate and reform Replace fan blade Check motor bracket mounting, tighten Compressor suspension bolts too tight Replace fan motor

Operating Instructions for TAI-2000D-12 Temperature Display & Alarm

Input Voltage

12 VAC Only DO NOT CONNECT THIS UNIT TO 120VAC

The line voltage of 120VAC shall be connected to the two (2) black leads, one with a white sleeve, from the transformer provided and attached to the exterior of the junction box located on the interior of the cooler above the door. These wires will be found within the junction box. Connect one black to the hot leg & one black with white sleeve to the neutral leg. Connect the green wire to ground. The two yellow wires with the fork terminals protruding from the center of the junction box must be connected to the 12VAC side of the transformer. Additional length may be obtained by loosening the black bushing and withdrawing ample wire to make the connection. Reference the wiring diagram on this sheet.

NOTE: (Prior to December 2002 both 120V leads were black & 12V black & white)

Back Up Power

Remove the faceplate of the unit and install a 9 Volt battery to the harness.

During a power failure, the unit will remain dark. The battery backup will allow a momentary check of temperature and will produce an audible alarm should the storage temperature exceed the alarm set points.

To check the temperature when in battery backup mode, depress the reset button. The current temperature will appear. The alarm, if activated, will silence for 5 minutes. After that, the unit will then become active again. This procedure will continue until the temperature returns within the designated set points.

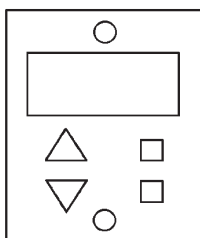

Programming Unit

To set the High Set Point temperature, depress the Set button until HSP appears. Push again to display the factory setting. Using the adjust buttons set the desired upper limit temperature.

To set the Low Set Point temperature, depress the Set button until LSP appears. Push again to display the factory setting. Using the adjust buttons set the desired lower limit temperature.

NOTE: If the programming sequence is interrupted for more than 15 seconds, or not completed to the point where the display flashes once, the unit will automatically revert back to the temperature display mode and to the factory settings for HSP & LSP without acknowledging any new set values.

Normal Operation

Following successful programming, if at any time the temperature within the cooler or freezer travels beyond the set limits (HSP or LSP), the display will flash and the alarm will sound. To silence the alarm push the reset button. The alarm will stop for 5 minutes. The display will continue to flash indicating an alarm condition and will continue to do so until the temperature within the unit returns within programmed settings. If after 5 minutes the temperature remains outside of desired conditions, the alarm will then sound again. The process for silencing the alarm may be repeated.

Three dots...on display indicates that the battery is low or is not installed.

Calibration "CAL"

Calibration "CAL": This temperature display on this unit may be calibrated either up or down if required. This is preset by the manufacturer. Do not attempt to change without checking with the customer service department at W.A. Brown & Son, Inc. Call 1.800.640.0593 for assistance.

During new installation it is suggested that the High Set Point (HSP) be temporarily set at 100° F and the Low Set Point (LSP) to -30° F to eliminate any unnecessary alarms when power is activated to this unit and the refrigeration in the cooler or freezer has yet to be started.

TAI 2000D-12 WIRING DIAGRAM

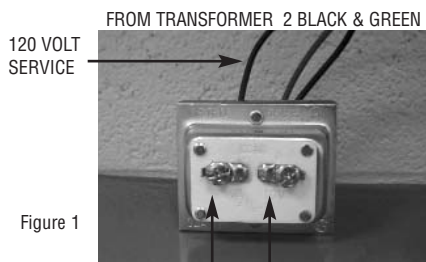

Figure 1

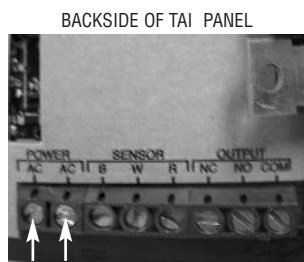

Figure 2

Black wire with spade terminal 10vac
White wire with spade terminal 10vac
THESE WIRES IN JUNCTION BOX

120 VOLT SERVICE

CONNECT INCOMING 120 VOLT SERVICE TO THE 2 BLACK WIRES AND GREEN GROUND WIRE FROM TRANSFORMER. THESE WIRES ARE IN THE JUNCTION BOX ON INSIDE OF DOOR PANEL. SEE FIGURE 1.

CONTROL VOLTAGE FOR TAI 2000D-12

CONNECT WHITE AND BLACK WIRES WITH SPADE TERMINAL CRIMPED ON ENDS LOCATED IN JUNCTION BOX TO SECONDARY TERMINALS ON TRANSFORMER. SEE FIGURE 1 & 2.

Free Manuals Download Website

<http://myh66.com>

<http://usermanuals.us>

<http://www.somanuals.com>

<http://www.4manuals.cc>

<http://www.manual-lib.com>

<http://www.404manual.com>

<http://www.luxmanual.com>

<http://aubethermostatmanual.com>

Golf course search by state

<http://golfingnear.com>

Email search by domain

<http://emailbydomain.com>

Auto manuals search

<http://auto.somanuals.com>

TV manuals search

<http://tv.somanuals.com>