

Installation

Operation

Service Manual

for

Forced Draft Steam

Boilers

BRYAN BOILERS
783 N. CHILI AVENUE, PERU, INDIANA 46970
Telephone: 765-473-6651 / Fax: 765-473-3074

E-Mail: bryanboilers@iquest.net / Internet: www.bryanboilers.com

INSTALLATION INSTRUCTIONS FORCED DRAFT STEAM BOILERS

NOTE:

- Please read all of instruction manual before attempting installation.
- Insurance and local or state regulatory codes may contain additional or more stringent requirements than those contained in this manual. Installation must conform to these codes and any other authority having jurisdiction.

1.1 BOILER FOUNDATION

Before uncrating, the boiler location should be prepared. The boiler should set upon a good level concrete floor. If the boiler is not level or the floor in good condition, a concrete foundation should be built, the dimensions larger than the outside dimensions of the boiler base.

DO NOT INSTALL BOILER ON COMBUSTIBLE FLOORING. The only exception to this is UL Labeled F -Series boilers which may be installed on combustible flooring.

IMPORTANT

If the boiler is installed directly on a concrete floor where it is important that the floor be kept cool (such as an upper floor or mezzanine or when sitting over wiring conduits) set the boiler up on insulating tile or steel framework so that air may circulate underneath. For atmospheric gas fired boilers, it is advisable to build up an insulating floor under the boiler using high temperature mineral fiber board at least 1 1/2" thick.

1.2 CLEARANCES

See Table 1 for minimum clearances to wall, ceilings, or obstructions. The clearances in Table 1 are intended as a general recommendation only. Local codes must be applied to specific installations and the minimum clearances established accordingly. Provisions must also be made for service, accessibility and clearance for piping and electrical connections.

Do not obstruct combustion air and ventilation openings with piping or any other construction. All

boilers must be installed in a space which is large, compared to the boiler. Only UL Labeled F-Series boilers are suitable for installation on combustible flooring.

NOTE

ADHERE TO ALL APPLICABLE LOCAL CODES REGARDING BOILER INSTALLATION AND CLEARANCES.

1.3 UNCRATING THE BOILER

Uncrate the boiler near its permanent location. Leave it on the bottom crating until ready to place permanently. Leave the plastic shroud on the boiler until all piping work is complete, cutting holes in the plastic for access to connections.

Remove the bolts attaching the boiler to the crate at the underside of the bottom crating. Lift or slide the boiler off of the bottom crating into position. Be careful not to tip the boiler up on one corner or side, which could cause damage to jacket.

MINIMUM CLEARANCES

NOTE: These boilers are intended to be installed in a room which is large compared to the size of the boiler. They are not intended for alcove installation and are suitable for installation on non-combustible flooring only.

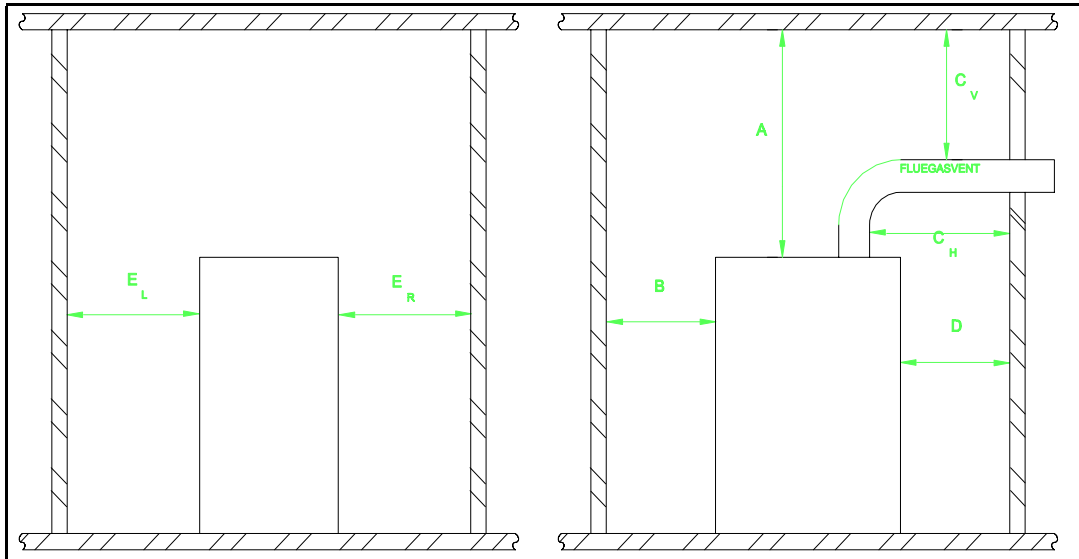

DIMENSION	D-SERIES		F-SERIES ¹		CL-SERIES		K-SERIES		RV, RW & AB SERIES	
	WATER/ STEAM TO 50#	STEAM OVER 50#	WATER /STEAM TO 50#	STEAM OVER 50#	WATER /STEAM TO 50#	STEAM OVER 50#	WATER /STEAM TO 50#	STEAM OVER 50#	WATER /STEAM TO 50#	STEAM OVER 50#
A	18"	36"	18"	48"	24"	24"	18"	36"	24"	24"
B	24"	24"	48"	96"	48"	36"	48"	24"	48"	48"
C _V & C _H	18"	36"	18"	36"	24"	24"	24"	24"	24"	24"
D	48"	96"	18"	36"	24"	24"	24"	24"	24"	24"
E _L & E _R	24"	24"	18"	36"	24"	24"	24"	24"	32"	32"

1 - F-Series boilers are approved for installation on combustible flooring. Do not install on carpeting.

- A - Clearance above boiler
- B - Front of boiler
- C_V - Clearance from gas vent, measured vertically above pipe
- C_H - Clearance from gas vent, measured horizontally or below pipe
- D - From back of boiler
- E_L - Left side of boiler
- E_R - Right side of boiler

These clearances are general minimum clearances. Local codes may dictate larger clearances.

1.4 BOILER CONNECTIONS

1.4.1 GENERAL

Do not run any pipes along the access panel side of the boiler. Maintain clearances as shown on the dimensional drawing for servicing of the boiler tubes. Provide at least 36" from the gas train and burner, unless a larger dimension is indicated on the dimensional. All piping should be designed and installed to avoid any loadings on the boiler connections or piping.

1.4.2 STEAM SUPPLY CONNECTION

A steam shut-off valve must be installed between each boiler and the steam main. This valve must be of the outside screw and yoke design to allow indication from a distance whether the valve is open or closed.

1.4.3 FEEDWATER CONNECTION

Install a check valve and a globe valve between the feed pump and the boiler. It is also recommended to install a globe valve between the feed pump and the receiver

tank. This valve can then be adjusted to bypass excess pump capacity to better control the boiler feed rate.

1.4.4 SAFETY RELIEF VALVE(S)

A connection is provided in the top of the boiler for the relief valve. The relief valve discharge piping must be the same size as the relief valve discharge opening. Avoid over-tightening as this can distort valve seats. All piping from relief valve must be independently supported with no weight carried by the valve.

1.4.4 BLOWDOWN CONNECTION

Blowdown valve(s) must be full size of the connection on the boiler. Steam boilers 15 psig and below require at least one blowdown valve. Higher pressure boilers require two blowdown valves with one or both valves being slow opening type. Each water column and float type low water cut-off must be equipped with a blowdown valve.

1.5 GAS SUPPLY CONNECTION - FORCED DRAFT UNITS

The installation must conform completely to the requirements of the authority having jurisdiction, or in the absence of such, requirements shall conform in the U.S. to the current National Fuel Gas Code, ANSI Z223.1-1984, or in Canada to the current Installation Code for Gas Burning Appliances and Equipment (CAN/CGA B149.1-M91), or Oil Burning Equipment (CSA B139-M91), and applicable regional regulations for the class; which should be followed carefully in all cases.

Drip leg must be installed on gas supply piping.

Consult the local gas utility company for inspection and authorization of all gas supply piping and flue connections.

The regulator vent line must be vented to outside of building on any boiler equipment with electric gas pilot ignition.

1.5.1 DRIP LEG

A drip leg or sediment trap must be installed in the gas supply line. See Fig. 1.5A. The gas line must be connected to a supply main at least as large as the gas train connection at the boiler. This connection should be made with a union so that the boiler gas train components and burner may be easily removed, if necessary, for service.

1.5.2 GAS PIPING LEAK TEST

After completion of the gas piping hookup, the installation must be checked for leaks, using a soap and water solution. Disconnect the boiler and gas train from the gas supply piping during any pressure testing of the gas supply system.

1.5.3 VENTING OF GAS TRAIN COMPONENTS

Gas pressure regulator - The regulator must be vented to the outside air, using minimum 1/4" tubing or pipe. The vent line should terminate in a downward direction to be free of restriction.

Diaphragm gas valves (V48A or V88A) - The vent line off of these gas valves must be vented to outdoors, the same as the regulator.

Normally open vent valves - These valves must be piped to outdoors using pipe no smaller than that of the valve.

Gas pressure switches - Vent these switches to outdoors using a minimum of 1/4" tubing or piping.

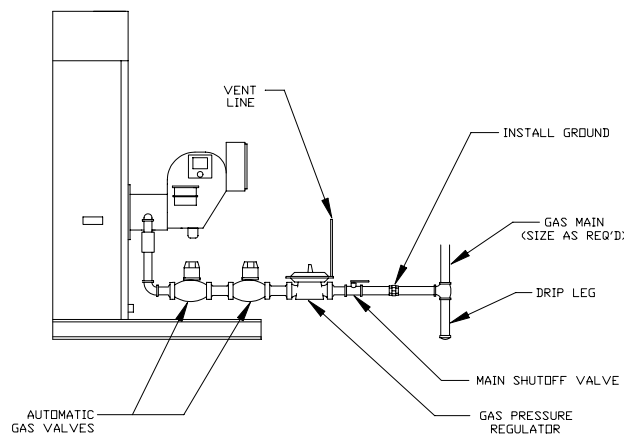

FIGURE 1.5A: GAS BURNER CONNECTION

NOTE: USE PIPE COMPOUND, WHICH IS RESISTANT TO THE ACTION OF LIQUID PETROLEUM GAS. DO NOT USE TEFLON TAPE.

1.6 ELECTRICAL CONNECTION

IMPORTANT: All electrical connections must conform to the National Electrical Code and to all other applicable State and Local Codes. Forced draft boilers may require a high voltage connection. See boiler wiring diagram and equipment list for

details.

Equipment Grounding - The boiler must be grounded in accordance with the American National Standard Electrical Code, ANSI/NFPA #70-1981.

1.7 COMBUSTION AIR SUPPLY

IMPORTANT: Positive means for supplying an ample amount of outside air, allowing complete combustion of the gas, must be provided.

Movable combustion air dampers, automatic or manually adjustable, must be electrically interlocked with the boiler to prevent boiler operation if the dampers are closed.

Combustion air openings must never be blocked or obstructed in any manner.

The boiler room must be at a positive or neutral pressure relative to the outdoors. A negative in the boiler room will result in downdraft problems and incomplete combustion due to lack of air.

WARNING!

Failure to provide an adequate air supply will result in boiler damage and hazardous conditions in the building (fire and asphyxiation hazard as well as equipment damage).

COMBUSTION AIR: Complete combustion of natural or propane gas requires approximately ten cubic foot of air (at sea level and 70°F) for each 1000 Btu of boiler input. In reality, additional air is required to achieve complete combustion. Air is also required for the proper operation of the appliance draft diverter or barometric damper. The combustion air opening recommendations below are designed to provide the air needed for atmospheric gas fired boilers which are equipped with either draft diverters or barometric dampers. Combustion air openings for boilers which are equipped with forced draft burners may be reduced to 70% of that required for atmospheric gas fired boilers. This is because the forced draft

boiler is not equipped with a draft control device (so no air is required for draft control).

COMBUSTION AIR OPENINGS - AREA REQUIRED:

Openings directly through outside wall -

One opening within 12 inches of the ceiling plus one opening within 12 inches of the floor. **Each** opening must have a minimum free area of 1 square inch per 4,000 Btu of total input of all air using appliances in the room.

Example: A boiler room having two boilers with 500,000 Btu input would require two openings through an outside wall, and each opening must have at least 250 square inches of free area.

Openings through vertical ducts -

One duct in the ceiling plus one duct terminating within 12 inches of the floor. **Each** opening must have a minimum free area of 1 square inch per 4,000 Btu of total input of all air-using appliances in the room.

Example: A boiler room having four boilers with 250,000 Btu input would require two ducts, one in the ceiling and one terminating near the floor, each opening having at least 250 square inches of free area.

Openings through horizontal ducts -

One duct opening within 12 inches of the ceiling plus one duct opening within 12 inches of the floor. **Each** opening must have a minimum free area of 1 square inch of per 2,000 Btu of total input for all equipment in the room. NOTE: No rectangular duct may have a dimension of less than 4 inches.

Example: A boiler room having 1 million Btu total input would require two ducts, one in the ceiling and one near the floor, each opening must having at least 500 square inches of free area.

Ventilation Air: In addition to air needed for combustion, sufficient air must be supplied for ventilation, including air required for comfort and proper working conditions for personnel in the boiler room. In colder climates, provision should also be made to heat the boiler room, if necessary, for personnel comfort.

CAUTION

Protection from combustion air contamination: Where corrosive or flammable process fumes are present in the vicinity of the boiler room or the air stream for the combustion air supply, it is essential that suitable means be provided for their safe

disposal. The boiler room and the combustion air supply must not be exposed to the fumes. Such fumes include, but are not limited to, carbon monoxide, hydrogen sulfide, ammonia, chlorine, and halogenated hydrocarbons.

NOTE: Halogenated hydrocarbons are particularly injurious and corrosive after exposure to high temperatures.

1.8 CHIMNEY, FLUE PIPE & DRAFT CONTROL - FORCED DRAFT BOILERS

CODE COMPLIANCE

The installation must conform to the requirements of NFPA 54, the National Gas Code (ANSI Z223.1-1984), Part 7, "Venting of Equipment", or to the applicable requirements of all local building codes. For factory-built and listed chimney systems (such as type B vent), consult the system manufacturer's instructions for correct installation procedures. Gas vents may be of any of the construction types listed in this manual. No portion of a venting system may extend into or pass through any circulating air duct or plenum.

MINIMUM SAFE PERFORMANCE

Venting systems must be designed to develop positive flow adequate to remove flue gases to the outside atmosphere. Guidelines are provided in this manual and in the National Fuel Gas Code, NFPA 54, for sizing and design of flue gas venting systems. For additional reference to good practice in vent design, refer to the "Chimney, Gas Vent, and Fireplace Design" chapter of the ASHRAE Equipment Handbook.

OUTSIDE VENTS AND CHIMNEYS

Outside uninsulated single wall pipe is not recommended for use in cold climates for venting gas-fired appliances since temperature differentials may cause corrosion in such pipe, as well as poor draft on start ups. When local experience indicates that condensate may be a problem, provisions should be made to drain off the condensate in the gas vent or chimney.

ESTIMATING FLUE GAS FLOW RATE (ACFM)

Flue gas volumetric flow rate in SCFM (standard cubic feet per minute) and ACFM (actual cubic feet per minute) can be estimated by using the information in 1.8.1A. Divide the Total Input of appliances connected to the chimney or vent by 1000. Then multiply this result times the factor listed in the SCFM and ACFM table. The ACFM data is required for determining stack exit velocity and induced draft fan requirements.

ESTIMATING STACK EXIT VELOCITY

First, determine the ACFM for the stack as described above. Multiply the total ACFM times the Velocity Factor from the Velocity Table in Table 1.8.1B for the stack diameter used. The result is the Stack Exit Velocity in feet per second.

ESTIMATING STACK EMISSIONS

Table 1.8.1C lists approximate emissions of NO_x (oxides of nitrogen) and CO (carbon monoxide). The table lists both the concentration, in parts per million (ppm), and the flow rate, in pounds per hour (PPH), of each compound: Divide the total input of appliances connected to the chimney or vent by 1,000,000. Then multiply this result times the value listed in the table for PPH emissions.

MANUAL REFERENCES

See Figure 1.8.1 for a graphics listing of applicable sections of this manual for each section of the vent system.

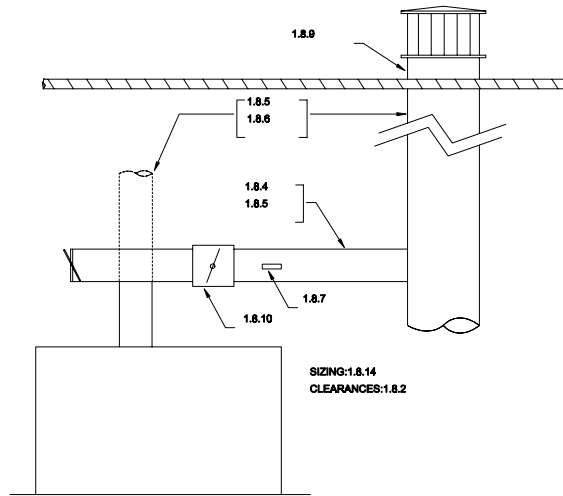

FIG. 1.8.1: VENT DESIGN INSTRUCTION - REFERENCES

TABLE 1.8.1A: ESTIMATING FLUE GAS VOLUMETRIC FLOW RATE

Approximate Flue Gas VOLUMETRIC FLOW RATE (Per 1000 Btu/hr Input) (Multiply factor listed times boiler input in MBH)			
BOILER TYPE	SCFM Per 1000 Btu/hr INPUT	ACFM Per 1000 Btu/hr INPUT	APPROXIMATE FLUE GAS TEMPERATURE
Water & 15# Steam Gas Fired	0.230	0.402	450°F
Oil Fired	0.230	0.402	450°F
150# Steam Gas Fired	0.230	0.425	500°F
Oil Fired	0.230	0.425	500°F

TABLE 1.8.1B: STACK EXIT VELOCITY

Estimated STACK EXIT VELOCITY Calculation (Multiply total ACFM times the velocity factor below velocity in feet per second)					
STACK INSIDE DIAMETER (Inches)	VELOCITY FACTOR	STACK INSIDE DIAMETER (Inches)	VELOCITY FACTOR	STACK INSIDE DIAMETER (Inches)	VELOCITY FACTOR
6	0.0849	18	0.00943	34	0.00264
7	0.0624	20	0.00764	36	0.00236
8	0.0477	22	0.00631	38	0.00212
10	0.0306	24	0.00531	40	0.00191
12	0.0212	26	0.00390	48	0.00133
14	0.0156	28	0.00340	60	0.00085
16	0.0119	32	0.00298		

TABLE 1.8.1C: ESTIMATING FLUE GAS EMISSIONS

Estimated Emissions (Volumetric Flow Rate Per Million Btu/hr Input) (Multiply PPH listed times boiler input divided by 1,000,000)										
BOILER TYPE	PARTICULATES		NOx		CO		SOx		Hydrocarbons	
	PPH per MMBH	PPM	PPH per MMBH	PPM	PPH per MMBH	PPM	PPH per MMBH	PPM	PPH per MMBH	PPM
Gas Fired	N/A	N/A	0.049	50	0.194	200	N/A	N/A	0.010	10
Oil Fired	0.020	20	0.068	70	0.018	18	0.286	290	0.004	4

1.8.2 CLEARANCES

The vent system and draft control devices must be installed so as to achieve the clearances to surfaces outlined in Table 1.2.1, Minimum Clearances chart, in this manual. See also Table 1.8.9 for vent clearances. All clearances must comply with the National Fuel Gas Code (NFPA54), and with all

local and state building codes. The clearances described in this manual are intended to be general guidelines only, additional requirements may occur because of local building design regulations.

1.8.3 BOILER ROOM PRESSURIZATION

The boiler room must be supplied with adequate air for combustion and for proper operation of draft control devices (barometric dampers or draft

diverters) as outlined in "Combustion Air Supply", Section 1.7 of this manual.

WARNING

THE BOILER ROOM MUST BE MAINTAINED AT A POSITIVE OR NEUTRAL PRESSURE (RELATIVE TO OUTDOORS) AT ALL TIMES. EXHAUST FANS OR CONNECTIONS FROM THE BOILER ROOM TO ZONES OF NEGATIVE PRESSURE (AIR DUCTS, NEGATIVE PRESSURE ROOMS, ETC.) WILL CAUSE NEGATIVE PRESSURE IN THE BOILER ROOM. SUCH CONDITIONS WILL CAUSE HAZARDOUS OPERATION OF THE BOILER AND INTRODUCTION OF COMBUSTION PRODUCTS INTO THE BUILDING AIR.

INDUCED DRAFT FAN WILL BE REQUIRED. FURTHER, THE BOILER MUST BE PROVIDED WITH A BAROMETRIC DRAFT CONTROL - NOT WITH A DRAFT DIVERTER. THE FAN MUST BE INTERLOCKED WITH THE BOILER AND A DRAFT PROVING SWITCH MUST BE INSTALLED TO PREVENT OPERATION OF THE BOILER IF THE FAN SHOULD FAIL TO OPERATE.

IF THE BOILER ROOM MUST BE UNDER A NEGATIVE PRESSURE AT ANY TIME, AN

IT ALSO MAY BE ADVISABLE TO INSTALL AN AUTOMATIC VENT DAMPER IN THE VENT SYSTEM TO PREVENT BACKFLOW THROUGH THE VENT SYSTEM DURING BOILER OFF CYCLES. SEE FOLLOWING SECTION ON AUTOMATIC VENT DAMPERS.

1.8.7 ACCEPTABLE VENT TYPES

LISTED GAS VENTS

Listed gas vents must be applied only on those applications for which they are listed. Type B gas vents are NOT listed for use on forced draft appliance vent systems.

Installation of these vents must comply with the vent listing, with the vent manufacturer's instructions and with complete adherence to the codes and clearances as outlined previously.

PRESSURIZED VENT SYSTEMS

Some Bryan Boilers (unless specifically fitted for the application) are not suitable for operation on a pressurized vent systems. Refer to Section 2 of this manual for the allowable range of vent pressure for each series. The RV, RW, and AB series boilers are designed for pressurized vent systems. All others require a neutral pressure.

SINGLE-WALL METAL PIPE

Single-wall metal pipe must be of galvanized sheet or other approved non-combustible corrosion resistant material, with minimum thickness per Table 1.8.7, from the National Fuel Gas Code. Single-wall metal pipe should be insulated to prevent excessive heat in the boiler room and to avoid ignition and spillage problems as well as corrosion from excessive condensation.

MASONRY, METAL AND FACTORY BUILT CHIMNEYS

Installation of factory built vents and chimneys must comply with the vent listing, with the vent manufacturer's instructions and with adherence to the codes and clearances as outlined herein. Masonry or metal chimneys must be built and

installed in accordance with nationally recognized building codes or standards.

MASONRY CHIMNEYS FOR RESIDENTIAL APPLICATIONS MUST BE LINED WITH FIRE-CLAY FLUE LINING (KX C315 OR THE EQUIVALENT) WITH THICKNESS NOT LESS THAN 5/16 INCH OR WITH A LINER OF OTHER APPROVED MATERIAL THAT WILL RESIST CORROSION, SOFTENING OR CRACKING FROM FLUE GASES AT TEMPERATURES UP TO 1800°F.

EXISTING CHIMNEYS SHOULD BE INSPECTED FOR UNSAFE CONDITIONS, SUCH AS DETERIORATED MASONRY AND EXCESSIVE SOOT OR OTHER BLOCKAGE OR POTENTIAL BLOCKAGE. SEE ALSO SECTION 1.8.6.

EXISTING CHIMNEYS MUST BE PROPERLY SIZED FOR THE FLUE GAS LOADING TO BE USED. THAT IS, IF AN EXISTING CHIMNEY IS USED FOR A SMALLER TOTAL INPUT THAN ITS ORIGINAL DESIGN, A LINER OR VENT IS REQUIRED. THE USE OF A PROPERLY SIZED GAS VENT OR LINER WILL PREVENT DETERIORATION OF THE CHIMNEY DUE TO THE EXCESSIVE CONDENSATION WHICH RESULTS ON OVERSIZED SYSTEMS.

WARNING

UNDER NO CIRCUMSTANCES SHOULD THE FLUE PIPE BE CONNECTED TO THE CHIMNEY OF AN OPEN FIREPLACE.

TABLE 1.8.7A WATER BOILER & STEAM BOILERS TO 50 PSIG		TABLE 1.8.7B (STEAM BOILERS OVER 50 PSIG)	
Diameter of Connector, Inches	Minimum Thickness, Inch (Gauge)	Diameter of Connector, Inches	Minimum Thickness, Inch (Gauge)
6 to 10	0.023 (24)	14 and less	0.053 (16)
10 to 12	0.029 (22)	14 to 16	0.067 (14)
12 to 16	0.034 (20)	16 to 18	0.093 (12)
16 +	0.056 (16)	18 +	0.123 (10)

1.8.5 VENT CONNECTORS (HORIZONTAL RUNS)

CONSTRUCTION

Vent connectors may be of any of the acceptable constructions listed in this manual.

AVOID UNNECESSARY BENDS

The vent connector must be installed so as to avoid turns or other construction features which create excessive resistance to flow of flue gases.

JOINTS

Vent connectors must be firmly attached to draft diverter outlets or boiler flue collars by sheet metal screws or other approved means. Vent connectors of Type B vent material must be assembled in accordance with the vent manufacturer's instructions. Joints between sections of connector piping must be fastened using sheet metal screws or other approved means.

SLOPE OR VENT CONNECTOR

The vent connector must be installed without any dips or sags and must slope upward at least 1/4 inch per foot.

LENGTH OF VENT CONNECTOR

The vent connector must be as short as possible and the boiler as close as practical to the chimney or vent.

The horizontal run of an uninsulated vent connector to a natural draft chimney or vent servicing a single appliance must not be more than 75% of the height of the chimney or vent above the vent connector.

The horizontal run of an insulated vent connector to a natural draft chimney or vent servicing a single appliance must not exceed 100% of the height of the chimney or vent above the vent connector.

SUPPORT OF VENT CONNECTOR

The vent connector must be supported in accordance with the vent manufacturer's instructions and listing and with all applicable codes. Support should also be independent of the boiler or the draft diverter (when used). The vent connector must be supported for the design and weight of the material employed to maintain clearances, prevent physical damage and separation of joints, and to prevent sagging of the vent connector.

Supports should usually be overhead hangers, of load bearing capacity appropriate for the weight involved.

LOCATION

When the vent connector used for an appliance having a draft hood must be located in or pass through a crawl space or other area difficult to access or which may be cold, that portion of the vent connector must be of listed double wall Type B gas vent material, or of material having equivalent insulation qualities. Single wall metal pipe used as a vent connector must not pass through any floor or ceiling.

CHIMNEY CONNECTION

In entering a passageway in a masonry or metal chimney, the vent connector must be installed above the extreme bottom to avoid stoppage. Means must be employed which will prevent the vent connector from protruding so far as to restrict the space between its end and the opposite wall of the chimney. A thimble or slip joint may be used to facilitate removal of the vent connector. The vent connector must be firmly attached to or inserted into the thimble or slip joint to prevent the vent connector from falling out.

DAMPERS

Manually operated dampers must not be placed in the vent connector. This does not exclude the use of fixed baffles, locking quadrant dampers which are welded in a fixed position, or automatic vent dampers (when properly installed and interlocked with the boiler gas controls).

USE OF THIMBLES

Vent connectors made of single wall metal pipe must not pass through any combustible wall unless they are guarded at the point of passage by ventilated metal thimbles 6" larger in diameter than the vent connector. This may be done only on water boilers and steam boilers rated for operation at no higher than 50 psig.

SINGLE WALL METAL VENT PIPE USED TO VENT STEAM BOILERS OPERATING OVER 50 PSIG MUST NOT PASS THROUGH WALLS OR PARTITIONS CONSTRUCTED OF COMBUSTIBLE MATERIAL.

1.8.6 CHIMNEY & VENT CONSTRUCTION (VERTICAL SECTION)

INSTALLATION OF FACTORY BUILT SYSTEMS

Listed gas vents and factory built chimneys must be installed in accordance with their listings and the manufacturer's instructions. Vents and venting systems passing through roofs must extend through the roof flashing, roof thimble or roof jack.

INSTALLATION OF MASONRY OR METAL CHIMNEYS

Masonry or metal chimneys must be built in accordance with nationally recognized building codes and standards.

INSTALLATION OF SINGLE WALL GAS VENTS

Single wall metal pipe may be used only for runs directly from the space in which the appliance is located through the roof or exterior wall to the outer air. A pipe passing through a roof must extend without interruption through the roof flashing, roof jack or thimble. Single wall metal pipe must not originate in any unoccupied attic or concealed space. Additionally, it must not pass through any attic, inside wall, concealed space or through any floor. Minimum clearance must be maintained between the single wall metal pipe and any combustible surface as outlined in Table 1.8.9.

When a single wall metal pipe passes through an exterior wall constructed of combustible material, it must be guarded at the point of passage by a ventilated thimble as described under "Use of Thimbles" in Section 1.8.8 of this manual.

Alternatively, a non-ventilating thimble not less than 18" above and 6" below the roof (with the annular space open at the bottom and closed at the top) may be used.

INSPECTIONS OF CHIMNEYS

Before connection of a vent connector to a chimney, the chimney passageway must be examined to ascertain that it is clear and free of obstructions. Cleanouts must be constructed such that they will remain tightly closed when not in use. Tee fittings used as cleanouts or condensate drains must have tight fitting caps to prevent entrance of air into the chimney at such points. When an existing masonry chimney is unlined and local experience indicates that vent gas condensate may be a problem, an approved liner or another vent must be installed. When inspection reveals that an existing chimney is not safe for the intended application, it must be rebuilt to conform to nationally recognized standards, relined with a suitable liner, or replaced with a gas vent or chimney suitable for the appliances to be attached.

SUPPORT OF CHIMNEYS AND VENTS

All portions of chimneys must be adequately supported for the design and weight of the materials employed. Listed factory built chimneys must be supported and spaced in accordance with their listings and the chimney or gas vent manufacturer's recommendations.

THE GAS VENT OR CHIMNEY MUST BE SUPPORTED INDEPENDENTLY OF THE BOILER TOP OR DRAFT DIVERTER.

EQUIPMENT TYPE	MINIMUM REQUIRED DISTANCE FROM COMBUSTIBLE MATERIAL		
	Listed Vent	Single Wall Metal Pipe	Factory Built Chimney
Water and 15 psig Steam Boilers	not permitted	18"	as listed
All Steam Boilers over 15 psig	not permitted	36"	as listed

1.8.7 MARKING OF GAS VENTS

In those localities where solid and liquid fuels are used extensively, gas vents must be plainly and permanently identified by a label reading:

"This gas vent is for appliances which burn gas only. Do not connect to incinerators or solid or liquid fuel burning appliances."

This label must be attached to the wall or ceiling at a point near where the gas vent connector enters the wall, ceiling or chimney.

The authority having jurisdiction must determine whether their area constitutes such a locality.

1.8.8 VENTING MULTIPLE APPLIANCES ON A COMMON VENT

COMMON GAS VENT

When two or more openings (for vent connectors) are provided in a chimney or gas vent, the opening should be at different levels. They should never be opposite one another.

When two vent connectors enter the same gas vent or chimney, the smallest of the two should enter at the highest position possible.

PRESSURIZED VENTS OR VENT CONNECTORS

DO NOT CONNECT THE FLUE OF AN APPLIANCE VENTED BY NATURAL DRAFT TO A VENT SYSTEM WHICH OPERATES UNDER A POSITIVE PRESSURE.

SOLID FUEL APPLIANCE VENTS

Gas appliances must not be vented to a vent or a chimney which serves a solid fuel burning appliance.

1.8.9 VENT AND CHIMNEY TERMINATIONS

HEIGHT ABOVE ROOF OR OBSTACLE

WATER BOILERS AND LOW PRESSURE STEAM BOILERS: No less than 3 feet above the roof and no less than 2 feet above any parapet or obstacle closer than 10 feet from the vent outlet.

HIGH PRESSURE (OVER 15 PSIG) STEAM BOILERS: No less than 10 feet higher than any portion of any building within a distance of 25 feet from the vent.

MINIMUM HEIGHT ABOVE DRAFT CONTROL

Chimneys and gas vents must extend at least 5 feet above the highest connected barometric draft control or any appliance flue outlet.

CLEARANCE FROM AIR INLETS

The vent or chimney must terminate no less than 3 feet above any forced air inlet within a distance of 10 feet. It must terminate no less than 1 foot above, or 4 feet below, or 4 feet horizontally from, any door, window or gravity air inlet into a building.

CLEARANCE FROM PUBLIC WALKWAYS

The vent exit of a mechanical draft system must be at least 7 feet above grade when located next to public walkways.

PROTECTION OF BUILDING MATERIALS FROM POSSIBLE CORROSION OR DISCOLORATION FROM FLUE PRODUCTS

The products of combustion from gas or oil contain potentially corrosive gases and high temperatures. For this reason, the chimney or vent exit must be designed to prevent exposure of the building materials to the flue products. Failure to do so may result in deterioration or discoloration of building materials.

VENT SUPPORT

The gas vent or chimney must be securely positioned and supported. Guy wires or other reliable means must be used to prevent movement of the vent.

PROTECTION AGAINST BLOCKAGE OR OBSTRUCTION

The chimney or vent exit design must prevent any possibility of blockage by snow or any other obstruction.

VENTILATING HOODS AND EXHAUST SYSTEMS

Ventilating hoods or exhaust systems may be used to vent atmospheric gas appliances. When these are used, however, such mechanical exhaust devices must be electrically interlocked with all appliances on the vent system. The circuit must prevent the operation of any appliance on the system if the hood or exhaust system is not in operation.

STACK CAPS

EVERY GAS VENT MUST BE SUPPLIED WITH AN APPROVED VENT CAP WHICH WILL PREVENT THE ENTRANCE OF RAIN OR OTHER PRECIPITATION INTO THE VENT. FAILURE TO PROVIDE SUCH A CAP MAY CAUSE SEVERE BOILER CORROSION, COMBUSTION PROBLEMS, OR BOTH.

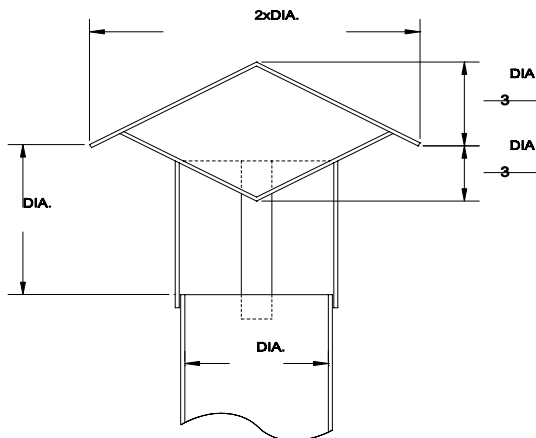

FIG. 1.8.12B: LOW RESISTANCE VENT CAP

Listed gas vents must be terminated with a listed cap, approved for use with the particular gas vent.

Listed vent caps or roof assemblies must have a rated venting capacity no less than the vent.

Single wall vents must terminate in an approved cap which does not obstruct the exit. The preferred type of cap for natural draft vented atmospheric boilers is the Briedert Cap. This is because of the protection this cap provides against wind-generated downdrafts.

Where there is no concern of high winds or turbulence at the vent exit, a low resistance conical cap may be used. See Fig. 1.8.12B for typical dimensions. The diameter of this type cap should be twice the vent diameter. The cap must be securely positioned on the vent such as to provide a clearance of one vent diameter above the vent exit.

1.8.10 AUTOMATIC VENT DAMPERS

ONE APPLIANCE ONLY

An automatic vent must be installed such that it serves only one appliance vent - that to which it is properly interlocked.

LISTING REQUIREMENTS

Automatic vent dampers, if used, must be of a listed type.

INSTALLATION

The damper installation must comply with Appendix I, J, or K of the National Fuel Gas Code, NFPA 54. The installation must also comply with the automatic vent damper listing, the damper manufacturer's instructions and all applicable local or state building codes.

AUTOMATIC VENT DAMPERS MUST BE INSTALLED ONLY BY QUALIFIED SERVICE TECHNICIANS. FAILURE TO PROPERLY INSTALL A VENT DAMPER WILL CREATE A SEVERE HAZARD.

PERFORMANCE TEST

The automatic vent damper must be tested after installation to assure its proper and safe operation.

AUTOMATIC VENT DAMPERS MUST BE IN THE OPEN POSITION AT ANY TIME THE APPLIANCE MAIN GAS VALVE IS ENERGIZED.

1.8.14 SIZING OF CHIMNEY AND VENT

IMPORTANT

The flue system calculations which follow in Section 1.8.15 are applicable to double-wall or insulated single wall breechings (vent connectors) and stacks (vents). Do not apply these calculations to uninsulated vent systems.

HIGH ALTITUDES

At altitudes of 2000 feet and higher, atmospheric boilers must be derated. The amount of derate required by the National Fuel Gas Code is 4% per 1000 feet above sea level. Boilers which are shipped from the factory prepared for these altitudes have the gas orifices properly sized for this derate. The altitude and gas Btu content for which the boilers have been constructed is listed on the Equipment List/Submittal Data in the boiler manual. The boilers will also be provided with a label indicating that they have been prepared for high altitude. If a boiler is to be installed at an altitude other than that for which it was factory built, orifices must be replaced to properly adjust

the gas input. Consult the factory or the local Bryan Representative for the proper parts. For the purpose of vent system sizing, assume full input and determine sizing as if at sea level. The derate factor of 4% per 1000 feet above sea level accounts for the increased volume per Btu/hr of flue products at high altitude.

INDUCED DRAFT FANS

Occasionally, the characteristics of an installation are such that a natural draft vent system will not suffice. In such cases, induced draft may be used. The vent system is then sized with an available "pumping" action equal to the total theoretical draft plus the static pressure capability of the induced draft fan. This will result in a smaller diameter vent than for a natural draft system. Sizing of induced draft fans should be done using the recommendations of the fan manufacturer and the ASHRAE Handbook.

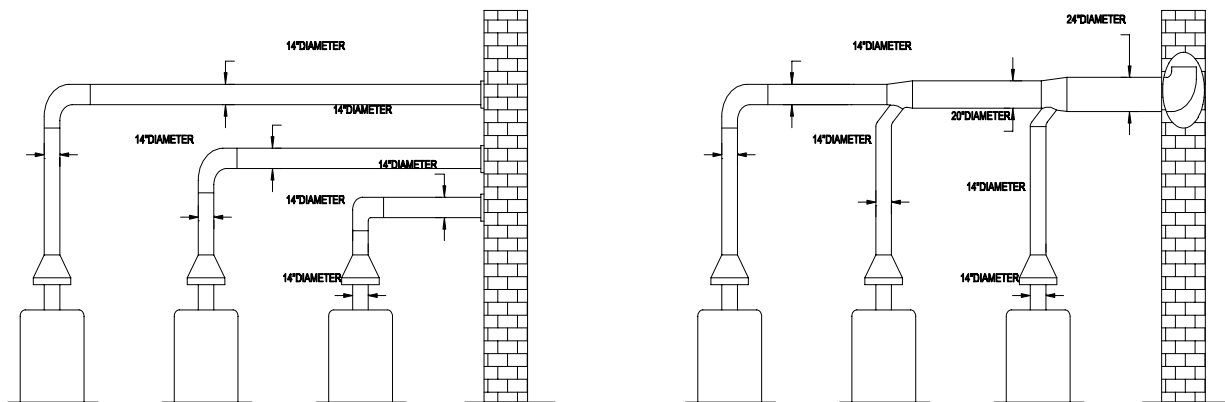

FIG. 1.8.14: SUGGESTED APPLIANCE VENTING PROCEDURE

MULTIPLE APPLIANCE INSTALLATIONS

Bryan recommends that boilers and other gas appliances be individually vented when possible. See figure 1.8.14A. Individual venting provides better draft control and fuel efficiency, and is less likely to cause condensation in the system. When

individual venting is not possible, boilers may be vented to a common breeching (vent connector). See Fig. 1.8.14B for recommended design of such a system. Note that connections of individual boiler or appliance vents into the common breeching should

be done with 45° elbows and not by "bullheading" directly into the vent connector at 90° angles. "Bullhead" connections generally cause excessive turbulence and poor draft conditions. On vent connectors serving multiple appliances, the diameter of the piping should be increased at each appliance's entrance so as to

provide a relatively constant flue gas velocity through the vent system. Using a constant diameter breeching will often result in poor draft at the outermost appliances.

1.8.12 QUICK SELECTION FOR VENT SIZING CHARTS

GENERAL

These charts were generated using the procedure described in Chapter 26 of the ASHRAE Equipment Handbook (1979). The results are consistent with those of the National Fuel Gas Code.

The sizing herein is applicable to vent systems utilizing double wall listed Type B vent as well as single wall insulated vent with insulation equivalent to double wall insulating value.

This sizing procedure is not applicable to vent systems utilizing single wall uninsulated vents or vent connectors.

The sizing information given herein is intended as a general recommendation only. Vent sizing and installation must comply with local codes.

The responsibility for assurance of such compliance is that of the system designer and/or the system installer. All sizing and installation

must be checked against such local requirements.

RECTANGULAR VENTS

Vent systems may be rectangular as well as circular. Table 1.8.15F has been provided to give the circular equivalent of rectangular duct. These equivalent values account for the higher pressure drop per cross section area for rectangular ducts.

STEP 1: EQUIVALENT INPUT - DRAFT CONTROL FACTOR

Determine the boiler (system) Draft Control Factor, F_1 , from Table 1.8.15A.

Determine the boiler (or total system) input in MBH. This is done by dividing the boiler (or total system) input in Btu/hr by 1000.

Multiply the total input times factor F_1 .

The equivalent input, I , (without altitude correction) is then:

$$I = \text{MBH} \times F_1 \quad \text{eq. 15A}$$

TABLE 1.8.15A: DRAFT CONTROL FACTOR F_1 Multiply factor time input in MBH	
Boiler Type	Factor, F_1
Atmospheric with Draft Hood	1.000
Atmospheric with Barometric	0.741
Forced Draft Gas or Oil	0.602

STEP 2: EQUIVALENT INPUT - ALTITUDE FACTOR

Determine the boiler (system) Altitude Correction Factor, F_2 , from Table 1.8.15B.

Multiply the boiler (or total system) input times factors, F_2 and F_1 for the equivalent input.

The altitude correction factor, F_2 for atmospheric boilers is equal to 1, because their inputs are already derated for altitude.

The equivalent input, I , with corrections for altitude is:

$$I = \text{MBH} \times F_1 \times F_2 \quad \text{eq. 15B}$$

Table 1.8.15B ALTITUDE CORRECTION FACTOR, F_2 (Multiple factor times sea level input, MBH)			
Altitude (ft)	Factor, F_2	Altitude (ft)	Factor, F_2
0 to 1999	1.00		
2000	1.075	6000	1.247
2500	1.096	6500	1.272
3000	1.116	7000	1.296
3500	1.136	7500	1.322
4000	1.157	8000	1.346
4500	1.180	8500	1.373
5000	1.202	9000	1.399
5500	1.25	10000	1.453

STEP 3: SELECT TRIAL DIAMETER

Determine the NET STACK HEIGHT for the vent. (The net stack height is the vertical distance from the top of the atmospheric boiler draft control to the top of the stack. On forced draft boilers it is the distance from the boiler flue connection to the top of the stack.)

Find the vent of TRIAL STACK DIAMETER. Enter Table 1.8.15C at the Net Stack Height column equal to the system net stack height. Then proceed down the column to the input which is just larger than the equivalent to an input which is just larger than the Equivalent Input of the system. Read the Trial Stack Diameter in the left hand column.

NOTE: This is only a trial diameter. Proceed to Step 4 to calculate the system k-factor to determine the actual stack diameter required.

STEP 4: CALCULATE SYSTEM K-FACTOR

The system "k-factor" accounts for the pressure drop through fittings and vent piping. It is calculated by adding up the individual k-factors for each of the fittings plus the k-factor for the vent pipe(s).

From Table 1.8.15D find the k-factors for each of the elbows, tee fittings, draft regulators, etc. in the system. Then calculate the vent piping k-factor from the formula:

$$k_{\text{piping}} = 0.4 \times L/D \quad \text{eq. 15C}$$

L = total length of piping in feet

D = diameter of piping in inches

Add all the k-factors together to determine the total system k-factor:

$$k_{\text{total}} = k_{\text{piping}} + k_{\text{fittings}} \quad \text{eq. 15D}$$

NOTE: On multiple appliance systems, multiply the k-factor times 1.5. This is required only on atmospheric boiler vent systems, not on forced draft systems.

Table 1.8.15D: Vent Fitting k-Factors			
Vertical Draft Hood	1.50	Low Resistance Cap	
Barometric Draft Control	0.50		
Round Elbow, 90 deg F	0.75	Converging Exit	$(D1/D2)^4 - 1$
Round Elbow, 45 deg F	0.30	Cone	(D1 is larger than D2)
Tee or 90 degF Breeching	1.25	Tapered Reducer	$1 - (D2/D1)^4$
Y Breeching	0.75		(D1 is larger than D2)

STEP 5: CORRECT EQUIVALENT INPUT FOR SYSTEM K-FACTOR

The capacities listed in Table 1.8.15C are based on a system k-factor equal to 7.5. For any other k-factor, the vent capacity must be adjusted. This is accomplished by adjusting the equivalent input for the system using a k-factor correction factor, designated F_3 .

Refer to Table 1.8.15E for the equivalent input correction factor which applies to the k-factor calculated in Step 4. This factor is designated as F_3 .

Multiply the equivalent input calculated in Step 2 times factor F_3 from Table 1.8.15E. This step will yield a new equivalent input, I:

$$I = MBH \times F_1 \times F_2 \times F_3 \quad \text{eq. 15E}$$

Using this adjusted equivalent input, check the stack diameter by following Steps 2 thru 3 again. If the stack diameter remains the same, the sizing is complete. If not, redo Steps 4 thru 5 etc. until an acceptable result is achieved.

Table 1.8.15E: K-Factor Equivalent Input Correction Factor F_3									
K- Factor F_3		K- Factor F_3		K- Factor F_3		K- Factor F_3		K- Factor F_3	
1.00	0.37	5.50	0.86	10.00	1.15	14.50	1.39	19.00	1.59
1.50	0.45	6.00	0.89	10.50	1.18	15.00	1.41	19.50	1.61
2.00	0.52	6.50	0.93	11.00	1.21	15.50	1.44	20.00	1.63
2.50	0.58	7.00	0.97	11.50	1.24	16.00	1.46	20.50	1.65
3.00	0.63	7.50	1.00	12.00	1.26	16.50	1.48	21.00	1.67
3.50	0.68	8.00	1.03	12.50	1.29	17.0	1.51	21.50	1.69
4.00	0.73	8.50	1.06	13.00	1.32	17.50	1.53	22.00	1.71
4.50	0.77	9.00	1.10	13.50	1.34	18.00	1.55	22.50	1.73
5.00	0.82	9.50	1.13	14.00	1.37	18.50	1.57	23.00	1.75

Stack Diam. (in.)	Table 1.8.15C: Approximate Stack Capacities (MBH) (Based on Atmospheric Boiler with Draft Hood)																			
	5	7	10	12	15	20	25	30	35	40	45	50	60	70	80	90	100	125	150	200
6	100	120	140	150	170	200	220	250	270	280	300	320	350	380	400	430	450	510	550	640
7	130	160	190	210	240	270	310	340	360	390	410	430	480	510	550	580	620	690	760	870
8	180	210	250	280	310	360	400	440	480	510	540	570	620	670	720	760	810	900	990	1140
9	220	270	320	350	390	450	510	560	600	640	680	720	790	850	910	970	1020	1140	1250	1450
10	280	330	400	430	490	560	630	690	750	800	850	890	980	1060	1130	1200	1260	1410	1550	1790
12	400	480	570	630	700	810	910	1000	1080	1150	1220	1290	1410	1520	1630	1730	1820	2040	2330	2580
14	550	650	780	860	960	1110	1240	1360	1470	1570	1660	1750	1920	2070	2220	2350	2480	2770	3040	3510
16	720	850	1020	1120	1250	1450	1620	1770	1920	2050	2170	2290	2510	2710	2900	3070	3240	3620	3970	4590
18	910	1080	1290	1420	1590	1830	2050	2250	2430	2590	2750	2900	3180	3430	3670	3890	4100	4590	5030	5810
20	1130	1340	1600	1750	1960	2260	2530	2770	3000	3200	3400	3580	3920	4240	4530	4810	5070	5670	6210	7170
22	1370	1620	1940	2120	2370	2740	3060	3360	3630	3880	4110	4340	4750	5130	5480	5820	6130	6860	7510	8680
24	1630	1930	2300	2530	2820	3260	3650	4000	4320	4610	4900	5160	5650	6110	6530	6920	7300	8160	8940	10330
26	1910	2260	2710	2960	3320	3830	4280	4690	5070	5420	5750	6060	6640	7170	7660	8130	8570	9580	10490	12120
28	2220	2630	3140	3440	3850	4440	4970	5440	5880	6280	6660	7030	7700	8310	8890	9430	9940	11110	12170	14060
30	2550	3010	3600	3950	4420	5100	5700	6250	6750	7210	7650	8070	8840	9540	10200	10820	11410	12760	13970	16140
32	2900	3430	4100	4490	5020	5800	6490	7110	7680	8210	8710	9180	10050	10860	11610	12310	12980	14510	15900	18360
34	3270	3870	4630	5070	5670	6550	7320	8020	8670	9270	9830	10360	11350	12260	13110	13900	14650	16390	17950	20730
36	3670	4340	5190	5670	6360	7350	8210	9000	9720	10390	11020	11620	12730	13750	14700	15590	16430	18370	20120	23240
48	6530	7730	9230	10120	11310	13060	14600	16000	17280	18470	19600	20660	22630	24400	26130	27710	29210	32660	35780	41320
54	8260	9780	11690	12810	14320	16530	18480	20250	21870	23380	24800	26140	28640	30930	33070	35080	36970	41340	45290	52290
60	10200	12070	14430	15810	17680	20410	22820	25000	27000	28870	30620	32280	35360	38190	40830	43310	45650	51040	55910	64560
72	14700	17390	20780	22770	25460	29400	32870	36000	38890	41570	44100	46480	50920	55000	58800	62360	65740	73500	80510	92970

NOTE: The above vent input capacities in MBH (thousands of Btu/hr) are sea level ratings for double wall or insulated vents allowing for a system K factor of 7.5. Apply the correction factors for altitude, other k-factors and boiler draft control correction factors.

Table 1.8.15F: CIRCULAR EQUIVALENTS OF RECTANGULAR BREECHINGS & STACKS

WIDTH (INCHES)	HEIGHT (INCHES)																	
	6	8	10	12	14	16	18	20	22	24	26	28	30	36	42	48	54	60
6	7	8	8	9	10	10	11	11	12	12	13	13	14	15	16	17	17	18
8	8	9	10	11	11	12	13	13	14	15	15	16	16	15	19	20	21	21
10	8	10	11	12	13	14	15	15	16	17	17	18	18	17	21	22	23	24
12	9	11	12	13	14	15	16	17	18	18	19	20	20	20	23	25	26	27
14	10	11	13	14	15	16	17	18	19	20	21	21	22	22	26	27	29	30
16	10	12	14	15	16	17	19	20	20	21	22	23	24	24	28	29	31	32
18	11	13	15	16	17	19	20	21	23	23	24	24	25	26	29	31	33	34
20	11	13	15	17	18	20	21	22	24	24	25	26	27	27	31	33	35	37
22	12	14	16	18	19	20	22	23	25	25	26	27	28	29	33	35	37	39
24	12	15	17	18	20	21	23	24	26	26	27	28	29	31	34	37	39	40
26	13	15	17	19	21	22	24	25	27	27	28	29	31	32	36	38	40	42
28	13	16	18	20	21	23	24	26	28	28	29	31	32	35	37	40	42	44
30	14	16	18	20	22	24	25	27	31	29	31	32	33	36	39	41	44	46
36	15	17	20	22	24	26	27	29	33	32	33	35	36	39	42	45	48	50
42	16	19	21	23	26	28	29	31	35	34	36	37	39	42	46	49	52	55
48	17	20	22	25	27	29	31	33	37	37	38	40	41	45	49	52	56	59
54	17	21	23	26	29	31	33	35	39	39	40	42	44	48	52	56	59	62
60	18	21	24	27	30	32	34	37	39	40	42	44	46	50	55	59	62	66

1.8.16 SPECIAL APPLICATIONS

FLUE GAS ECONOMIZERS

When applying flue gas economizers, care must be taken to assure that:

1. Proper draft must be maintained. This requires that the gas side pressure drop be considered and that the economizer exchanger must be designed so as to allow cleaning.
2. The vent system materials must be considered, regarding resistance from corrosion, which might result from the lower flue gas temperature.
3. In general, it is recommended that the boiler manufacturer be consulted when a flue gas economizer is to be added.

HIGH EFFICIENCY APPLIANCES

High efficiency appliances require special consideration in vent design because of the reduced stack gas temperatures. Under no circumstances can a condensing type appliance be vented into the same vent system with other appliances. The vent system for such appliances must be provided by or specified specifically by the manufacturer of the condensing appliance.

High efficiency non-condensing appliances should generally be installed only on vent systems that are resistant to corrosion from flue gas condensate. This generally requires stainless steel vent construction.

1.9 BURNERS AND GAS TRAIN - FORCED DRAFT BOILERS

GENERAL

Refer to separate manual on the forced draft burner for start-up and adjustment procedures. Do not attempt to start burner when excess oil has accumulated, or when the combustion chamber is full of gas, or if chamber is very hot.

FUEL CONNECTIONS

Gas supply connections must comply with the National Fuel Gas Code (NFPA54). Oil supply connections must comply with NFPA31. Any additional local or state codes must also be adhered to.

Oil supply lines must be sized for the circulation rate of the burner pump. This is referred to as the suction gear capacity of the pump. If a transfer pump is used, it must have a pumping capacity no less than the total suction gear capacity of all burner pumps on the system. Refer to Burner Manual for the suction gear capacity of standard oil pumps. Two-pipe oil systems are recommended in all cases, although a one-pipe system might be acceptable on smaller boilers (under 6 gph). Two-pipe systems tend to have fewer problems with air entrainment in the oil. Air in the oil will cause nuisance problems and delayed ignition.

1.10 PROCEDURES TO BE FOLLOWED BEFORE PLACING BOILER IN OPERATION

1.10.1 HYDROSTATIC TEST OF BOILERS AND SYSTEM

After completing the boiler and burner installation, the boiler connections, fittings, attachments and adjacent piping must be inspected for leaks by filling the unit with water. The pressure should be gradually increased to a pressure just below the setting of boiler safety relief valve(s).

Remove the boiler tube access panels (see dimensional drawing in this manual). Inspect the tube to header joints to be certain that all tube fittings are sealed. This is necessary because,

although the boiler is hydrostatically tested at the factory, minor leaks in fittings and at attachments can develop from shipping vibration or from installation procedures. It is often necessary to retighten such fittings after the installation and after the boiler has been operated for some time. Replace tube access panels before proceeding to start boiler.

1.10.2 TEST OF GAS PIPING

Reference gas system test under Section 1.5, "Gas Connection", in this manual.

START-UP AND OPERATION STEAM BOILERS

WARNING:

IMPROPER SERVICING AND START-UP OF THIS EQUIPMENT MAY CREATE A POTENTIAL HAZARD TO EQUIPMENT AND TO OPERATORS OR PERSONS IN THE BUILDING.

SERVICING AND START-UP MUST BE DONE ONLY BY FULLY TRAINED AND QUALIFIED PERSONNEL.

CAUTION:

BEFORE DISCONNECTING OR OPENING ANY FUEL LINE, OR BEFORE CLEANING OR REPLACING PARTS OF ANY KIND, TAKE THE FOLLOWING PRECAUTIONS:

Turn OFF the main fuel shutoff valves, including the pilot gas cock if applicable. If the burner is a multiple fuel type, shut OFF all fuel supplies.

Turn OFF all electrical disconnects to the burner, boiler and any other equipment or systems electrically interlocked with the burner or boiler.

All cover plates, enclosures, and guards must be in place at all times except during maintenance and servicing.

2.1 FIRING RATE ADJUSTMENT - ATMOSPHERIC GAS UNITS

2.1.1 The following procedures must be followed carefully before putting the boiler in operation. Failure to do so will present severe hazards to equipment, operating personnel and building occupants.

2.1.2 ADJUST PILOT BURNER

Carefully follow the Lighting Instructions in the boiler manual for the proper adjustment of the pilot burner. This is absolutely essential before attempting to adjust the main burner.

2.1.3 ADJUST BOILER INPUT(S)

The boiler input must be adjusted for both maximum and minimum input values which are listed on the boiler nameplate. First adjust the maximum input rating using the method described in Lighting Instructions in the Boiler Manual. Refer to the following information for the adjustment of the minimum input. To determine the adjustment

which firing rate system is used, see the boiler Equipment List and Wiring Diagram.

2.1.4 ADJUST BOILER MINIMUM INPUT

After setting the correct Maximum input as described in the Lighting Instructions, proceed to adjust the minimum input as outlined below. This applies only to those boilers which are designed and equipped for two-stage (High/Low/Off) firing or Modulation. On those boilers which are equipped for ON/OFF firing only, no minimum input adjustment is required. NOTE: the low firing rate input is adjustable only on boilers equipped with two-stage or modulating motorized gas valves (V4055, V9055, or AH4 actuators) or with motor-operated modulating butterfly gas valves. The other two-stage firing systems (VR850 or VR852 combination valves or dual diaphragm valve type bypass systems) have a non-adjustable minimum input rate.

NOTE

THE LOW FIRE ADJUSTMENT SHOULD RESULT IN A GAS PRESSURE ON THE BURNER MANIFOLD EQUAL TO 1" WATER COLUMN FOR NATURAL GAS AND 3" FOR PROPANE GAS.

2.1.5 MINIMUM INPUT ADJUSTMENT - COMBINATION GAS VALVES (VR850 OR VR852)

The minimum input on these gas valves is NOT adjustable. The maximum input must be properly set as outlined in Lighting Instructions. See the manufacturer's instructions on the VR850 or VR852 included in the Boiler Manual for further information.

2.1.6 MINIMUM INPUT ADJUSTMENT - DUAL DIAPHRAGM GAS VALVE HIGH/LOW BY-PASS SYSTEM

The minimum input on this control system is NOT adjustable. The maximum input must be properly set as outlined in Lighting Instructions. This system consists of two V48A (120 volt coil) or two V88A (24 volts coil) diaphragm gas valves which are piped in parallel. The minimum input is controlled by an orifice plug installed in a coupling in the by-pass piping (low fire valve piping), sized for approximately 1" w.c. manifold pressure at low fire natural gas (2" w.c. if propane gas). When the high fire gas valve is not activated, gas flows only through the bypass piping. When the high fire gas valve is activated, gas will flow through both valves achieving full input.

2.2 FIRING RATE ADJUSTMENT - GAS METER READINGS

2.2.1 CHECKING BURNER INPUT

The burner input rate can be checked by taking readings from the gas meter. Please note checking the rate with a meter is the only way to be sure of input. Manifold readings are only an approximate value and may vary from unit to unit.

In order to obtain accurate data, there must be no other appliances using gas from the same meter while the burner input rate is being checked. The test hand on the meter should be timed for several revolutions. The input rate in cubic feet per hour is

calculated from this timing. The method is described in Lighting Instructions. If the meter is not calibrated for gas temperature and pressure, correction factors must be applied to determine correct rate in SCFH (standard cubic feet per hour). Consult the National Fuel Gas Code (ANSI Z223.1, NFPA 54) or the local gas utility for further information. Refer to Table 2.2A for correction factors for the gas pressure at the meter. Refer to Table 2.2B for the gas temperature correction factors.

Table 2.2A - Pressure Correction		Table 2.2B - Temperature Correction	
Gas Pressure at Meter	Correction Factor	Gas Temp. at Meter	Correction Factor
7" w.c.	1.017	40 °F	0.920
14" w.c.	1.034	50 °F	0.902
21" w.c.	1.051	60 °F	0.885
1 psig	1.061	70 °F	0.868
2 psig	1.136	80 °F	0.852
5 psig	1.340	90 °F	0.836

2.3 SAFETY SHUT-OFF DEVICES (FLAME SUPERVISION)

2.3.1 FLAME SUPERVISORY SYSTEM

The boiler is equipped with a flame supervisory system, either the Thermocouple type (such as a combination gas valve or a pilotstat) or electronic type (such as the RA890, or RM7895). The purpose of this device is to detect the main or pilot flame, depending on the type of device, and control the gas valves accordingly. The device must be checked for proper operation. See Lighting Instructions in the Boiler Manual for the correct procedure. The flame supervisory system must be tested to assure that it will shut off the main gas valves in case of a

flame loss. In addition to the information given in Lighting Instructions, operating sequence and troubleshooting information may be found in the manufacturer's instructions in the Boiler Manual.

2.3.2 AUTOMATIC (ELECTRIC) IGNITION SYSTEMS

On boilers equipped with automatic electrically ignited pilots, follow the procedures described in Lighting Instructions and test the controls for proper operation.

2.4 LIMIT CIRCUIT CUT-OUT TEST

2.4.1 PROTECTIVE DEVICES

All operating and limit controls and low water cutoffs must be tested for proper operation.

2.4.2 STEAM PRESSURE OPERATING CONTROL

The steam pressure in the boiler is regulated by the Boiler Operator. This is a pressure control which senses the steam pressure and turns the boiler on and off accordingly. This control must be operationally tested. Adjust the pressure setting on the control to a pressure less than the boiler pressure (as shown on the boiler pressure gauge). The control should turn the boiler off. Restore the control setting to normal. The boiler should cycle on.

2.4.3 HIGH LIMIT CONTROL

At least one additional pressure control is provided as the high limit control. It is set at a pressure above the operator to act as a back-up should the operator fail. The high limit control must be operationally tested. With the boiler operating, decrease the pressure setting of the limit control below the current pressure of the boiler. The boiler should cycle off. Restore the high limit control setting to normal (pushing reset button if it is a manual reset type). The boiler should now cycle on.

2.4.4 LOW WATER CUT-OFF(S)

Most boilers are supplied with a float-operated primary low water cut-off (and pump control or

water feeder combination) or electric probe type auxiliary control. These water level controls are intended to sense (and control) the level of the water in the boiler. They operate to shut off the boiler if the water level drops below their sensing level. The low water cut-off and water level controls must be operationally tested by manually lowering the boiler water level (by opening the boiler blowdown valve for probe controls, and by opening the control blowdown valve for float type controls). The boiler should cycle off when the water level drops below the control point of the low water cut-off. When the water level is restored, the boiler should cycle back on. Depress the manual reset button of devices which require manual reset in order to restore the boiler to operation. Carefully read the enclosed literature on the low water cut-off controls, particularly installing, operating and servicing.

2.4.5 COMBINATION LOW WATER CUT-OFF & FEEDER

The low water cut-off/feeder supplied with some boiler serves as a low water cut-off (see above) and also causes make-up water to be added to the boiler should the water level drop below its control point.

This type of control must be operationally tested as for low water cut-offs and also to assure that the make-up water is introduced as needed. Carefully read the enclosed literature on the Low

Water Cut-off controls, particularly installing, operating and servicing.

2.4.6 OTHER CONTROLS

Additional controls as required for the particular installation may also be provided. Refer to the literature on these devices included in the Boiler Manual. All such devices must be operationally tested to assure reliable operation of the boiler and system.

2.4.7 BOILER FEED SYSTEM

The boiler feed pump must be operationally tested to assure that it can provide boiler feedwater at the pressure and in the amount needed for safe and reliable boiler operation.

2.4.8 CHEMICAL FEED SYSTEM & SOFTENER

Check the performance of the boiler water softener and chemical treatment system. Chemically test the feedwater to be certain it complies with the recommendations of the chemical treatment consultant.

2.5 RECOMMENDED DRAFT AND COMBUSTION READINGS

ATMOSPHERIC GAS-FIRED BOILERS					
BOILER SERIES	DRAFT AT BOILER OUTLET (i.w.c.)	CO ₂ @ HIGH FIRE	O ₂ @ HIGH FIRE	CO (ppm)	SMOKE NO.
F	-0.01 TO -0.04	7.5 TO 8.5 %	5.0 TO 7.5 %	< 400	0
CL	-0.02 TO -0.04	7.5 TO 9.0 %	4.8 TO 7.5 %	< 400	0
K	-0.02 TO -0.06	8.0 TO 9.5 %	4.0 TO 6.7 %	< 400	0

FORCED DRAFT GAS FIRED BOILERS					
BOILER SERIES	DRAFT AT BOILER OUTLET (i.w.c.)	CO ₂ @ HIGH FIRE	O ₂ @ HIGH FIRE	CO (ppm)	SMOKE NO.
D	-0.01 TO -0.04	7.5 TO 9.5 %	4.0 TO 7.5 %	< 400	0
HED	-0.01 TO -0.04	7.5 TO 9.5 %	4.0 TO 7.5 %	< 400	0
CL	0.0 TO -0.04	8.5 TO 10.0 %	3.2 TO 5.0 %	< 400	0
HECL	0.0 TO -0.06	8.5 TO 10.0 %	3.2 TO 5.0 %	< 400	0
RV & RW	+0.50 TO -0.10	9.0 TO 10.0 %	3.2 TO 5.0 %	< 400	0
AB	+0.25 TO -0.06	9.0 TO 10.0 %	3.2 TO 5.0 %	< 400	0

FORCED DRAFT OIL FIRED BOILERS					
BOILER SERIES	DRAFT AT BOILER OUTLET (i.w.c.)	CO ₂ @ HIGH FIRE	O ₂ @ HIGH FIRE	CO (ppm)	SMOKE NO.
D	-0.01 TO -0.04	10.0 TO 12.0 %	4.0 TO 7.2 %	< 400	0
CL	0.0 TO -0.04	10.0 TO 12.0 %	4.0 TO 7.2 %	< 400	0
RV & RW	+0.50 TO -0.10	11.5 TO 12.5 %	3.7 TO 5.0 %	< 400	0
AB	+0.25 TO -0.06	11.5 TO 12.5 %	3.7 TO 5.0 %	< 400	0

NOTE: THE VALUES FOR CO₂ AND O₂ ARE SHOWN FOR HIGH FIRE ONLY. THE VALUES FOR LOW FIRE OR MID RANGE WILL GENERALLY BE LOWER, PARTICULARLY FOR ATMOSPHERIC GAS-FIRED BOILERS. DRAFT SHOULD BE MEASURED APPROXIMATELY 24" FROM TOP OF BOILER, BEFORE ANY DRAFT CONTROL.

2.5.1 DRAFT ADJUSTMENT - ATMOSPHERIC GAS BOILERS

Refer to Section 1.8.6 for the adjustment method for barometric dampers. Adjust the damper so as to yield a draft which results in values of CO₂ and CO within the allowable limits listed above in the appropriate table.

Draft adjustments are generally not required for boilers equipped with draft diverters. The diverter must be installed without modification. Combustion readings are required, however, to assure that the boiler operation is both safe and efficient.

Draft measurement should preferably be made with an inclined tube manometer. If a draft gauge is not available, check to be sure the flue gases are being carried up the venting system by passing a lighted taper or match around the edge of the draft hood relief opening (or barometric). If the venting system is operating correctly, the match flame will be drawn toward the draft hood relief opening. Otherwise the products of combustion will tend to push the flame and extinguish it.

CAUTION

IF THE PRODUCTS OF COMBUSTION ARE BEING EMITTED INTO THE ROOM (VENTING SYSTEM NOT OPERATING CORRECTLY), THE BOILER MUST NOT BE OPERATED UNTIL PROPER ADJUSTMENTS OR REPAIRS

ARE MADE TO ASSURE ADEQUATE DRAFT THROUGH THE VENTING SYSTEM.

2.5.2 DRAFT ADJUSTMENT -FORCED DRAFT BOILERS

Draft adjustments are generally not necessary on forced draft boilers. The draft must be measured as part of the start-up procedure. The measured draft at the boiler flue should fall within the recommended range specified in the appropriate table.

On some installations the draft may be excessive due to a high chimney. In these cases, the draft should be adjusted within the recommended range specified in the above appropriate table.

This may be done using a barometric damper, a restrictor, or a locking quadrant damper. Such devices must be installed and adjusted by a qualified technician.

2.5.3 COMBUSTION ADJUSTMENTS - FORCED DRAFT

Refer to the separate burner manual for the procedures for burner adjustments. The burner must be adjusted for smooth lightoff. Combustion parameters should be within the range specified in the above appropriate table. In no case should the level of CO be allowed to exceed the limit given, and the smoke spot reading must also not exceed the value shown.

2.6 OPERATING INSTRUCTIONS

2.6.1 FAMILIARIZATION WITH MANUAL(S)

The user of the boiler must familiarize himself with this manual and the burner manual for forced draft boilers to be sure he is prepared to operate and maintain the boiler properly.

The operating instructions should be kept in the pocket in the boiler for F Series boilers, or adjacent to the boiler for all others.

READ THE MANUAL BEFORE ATTEMPTING A START UP.

2.7 MAINTENANCE SCHEDULE

2.7.1 POSTING SCHEDULE

Post a maintenance schedule in accordance with the recommendations in this manual. A copy of a typical schedule is included in this manual.

Section 3

CARE AND MAINTENANCE STEAM BOILERS

CAUTION:

- The boiler area should be kept free of combustible materials, gasoline and other flammable liquids.
- The boiler and venting system must be kept free of obstructions of the air louvers and draft hood relief openings.
- The following procedures must be conducted as outlined to assure safe operation of the boiler.
- All cover plates, enclosures, and guards must be in place at all times except during maintenance and servicing.

3.1 REQUIRED PRECAUTIONS DURING TEMPORARY USE

GENERAL

A boiler is often utilized in new construction to assist in curing of building components or to provide temporary heat for the construction crew or for other purposes during the time the building is under construction. If precautions are not taken during this time to protect the boiler, a great deal of damage can occur before the ultimate owner takes over the building.

It is the mutual responsibility of the installing contractor and the boiler owner to consider the effect of temporary usage on the boiler warranty. The following should be observed so as to assure the longevity of the boiler.

OPERATOR SKILLS/RESPONSIBILITIES

During the temporary use period, a single individual must be assigned responsibility for the care and operation of the boiler. This person's responsibility must include, but not be limited to, the following:

1. Knowledge of burner/boiler operation.
2. Possession and understanding of boiler/burner operating instruction manual.
3. Assurance that the boiler is fed with only treated water at all times and that chemical treatment and blowdown procedures are always followed.
4. Notification to the manufacturer (or manufacturer's agent) to provide start-up services if the boiler was purchased with start-up by a factory representative.
5. Adherence to all of the start-up procedures noted in the boiler/burner manual.
6. Considerations of warranty should the boiler be used for temporary heat without adherence to the recommended start-up and operating procedures outlined in the instruction manuals.

3.2 CLEANING THE BOILER AND SYSTEM - NEW SYSTEMS

BOIL OUT PROCEDURE

The internal surfaces of a newly installed boiler will have oil, grease or other protective coatings used in manufacturing. Such coatings must be removed since these coatings lower the heat transfer rate and could lead to overheating of a tube and reduce operating efficiency. Before boiling out procedures may begin, the burner must be ready for firing. The operator must be familiar with the procedure outlined in the boiler/burner operating instruction manuals.

In combination with system contamination, bacteria may cause objectionable odors, sometimes resembling natural gas. It is important to keep these fumes from air intakes which would distribute them throughout the building. On steam humidification systems this is especially critical. Consult your local water treatment chemist for further information.

CAUTION

The boil out procedure outlined must be performed by, or under the direct supervision of, a qualified technician. The chemicals used present a hazard of burns and physical injury if mishandled. Always use suitable face mask, goggles, protective gloves and garments when handling caustic chemicals. Do not permit the chemical to come into contact with skin or clothing. Always follow the safety precautions on the container's label. Add chemicals slowly and in small amounts to prevent excessive heat and agitation. Do not add water to acid. Do not add water to dry chemical. This will cause splattering and/or explosion and severe risk of personal injury.

Boiling out under pressure is not recommended. If boil out under pressure is required, competent assistance must be provided.

Your water consultant or water treatment company will be able to recommend a cleaning or boil out procedure. In the event that such service is unavailable or as yet not selected, the following may be used.

1. The boil out of the boiler and system is neither difficult nor expensive. The chemicals needed for cleaning are readily available. Trisodium phosphate, and sodium hydroxide (lye) are the most commonly used chemicals. Use only one type of solution in the system. The amount of chemical required will vary according to conditions, but an amount of one pound of chemical per fifty gallons of water is suggested.

2. Before introducing the solution into the boiler, an overflow pipe should be attached to the top of the boiler and routed to a safe point of discharge.

3. Remove all safety valves to ensure that none of the solution will come into contact with the valve seats. Use care in removing and reinstalling valves.

4. All valves in the piping to and from the system must be closed to prevent the chemical solution from getting into the system.

5. Gauge glasses must be protected from contact with the boil out chemicals.

6. Fill the boiler with clean softened water until the water level reaches the upper header. Then add the cleaning solution into the upper header. Add more clean water until the boiler is completely filled. The water used for this initial fill should be at room temperature, and must be softened as noted.

7. After filling, fire the boiler intermittently (at low fire) at a frequency as necessary to hold the boiler solution at boiling point temperature. **DO NOT PRODUCE STEAM PRESSURE.** Boil the water, supervised at all times, for at least five hours.

8. After the five hour boil out, begin to add a small amount of fresh softened water so as to create a slight overflow of the overflow pipe. This will carry out impurities which have accumulated at the water surface. Continue to apply heat and overflow until the water emitted from the overflow pipe clears. Then shut off burner.

9. Let the boiler cool to 120°F or less. Then drain the boiler. Use caution that the water is discharged with safety.

10. Remove the inspection/cleanout openings in the boiler upper and lower headers and wash the waterside surfaces thoroughly using high pressure water stream.

11. Inspect the boiler's internal (waterside) surfaces thoroughly after the procedure. If the surfaces are not clean, repeat the boil out.

12. After boil out, close all openings. Install relief valves, gauge glasses and other components as necessary. Completely fill the boiler with fresh, softened, ambient temperature water. Fire the boiler at low fire until water temperature of at least 180°F is reached. This will drive off dissolved gases.

13. The boiler is now ready to operate.

IMPORTANT

If boiler is not to be operated within 24 hours, a lay-up procedure is required. Refer to instruction for lay-up.

3.3 SYSTEM CLEAN OUT

Many boilers have been ruined with system contaminants such as pipe dope, cutting oil, metal shavings or chips and other debris which are left in the piping. If these contaminants are not removed, they will end up in the boiler.

SYSTEM CLEANING PROCEDURE

For steam systems, the boiler will need to be connected to the header utilizing steam to purge the piping and thus push the debris out of the system. However, at this time all condensate must be wasted until it runs clear and water analysis of the condensate indicates that it is free of contaminants. Steam trap strainers must be periodically opened and cleaned of any debris which accumulates.

During this system clean out, the boiler make-up water must be properly softened and treated. At the conclusion of the system clean out, the condensate must be reconnected.

For old or existing steam systems, the installation process may have jarred debris loose. Following the boil out of the new boiler, the condensate should be wasted until it is within proper guidelines. Check all steam trap strainers to assure their cleanliness. Refer to the succeeding section on replacement boiler installations.

3.4 REPLACEMENT BOILER INSTALLATIONS: PROTECTION AGAINST CORROSION & SEDIMENT

BOILER MUST CONTROL FEED WATER

The water feed to the boiler must be controlled by the boiler-mounted water level control. It is unacceptable to use gravity return or to let the water feed be controlled by a condensate/receiver/ condensate pump system. The water feed to the boiler must be controlled:

- by a feed pump control which is mounted on the boiler. This control is to activate the feed pump on a boiler feed system. It will be necessary to supply such a system if not already installed. - OR -
- by an automatic water feeder mounted on the boiler. This is used only on systems requiring 100% make-up, such as humidification, steam process, etc.

NOTE

It is not recommended to provide the make-up for a closed steam heating system to the boiler by means of a water feeder. It is preferred that system make-up be connected to the condensate return tank of a boiler feed system.

A boiler feed system may be used in conjunction with an existing condensate receiver system by allowing the receiver system to pump condensate into the boiler feed system tank.

CLEAN OR REPLACE ALL SYSTEM PIPING AND HEATING UNITS

Arrange for chemical and mechanical cleaning of

the entire system. A chemical treatment company should be consulted for the proper means of this chemical cleaning.

Replace any piping considered to be deteriorated beyond safe or cleanable condition. Flush the system clean, being certain to isolate the boiler.

DO NOT FLUSH THE SYSTEM THROUGH THE BOILER

NOTE: For some old systems, there is a reluctance to clean the piping because of the possibility of leaks occurring in badly corroded lines. Should the customer refuse cleaning, it is necessary to install filtration equipment. Install either a fibrous filter or a centrifugal filter in the boiler return piping. This will collect and remove sediment from the system. A booster pump may have to be installed as well to overcome the additional pressure drop introduced in the line by the filter. When filling the system, provide chemical treatment as outlined in Section 3.5.

CAUTION

Failure to properly clean the system or to install mechanical sediment removal equipment can result in tube blockage and severe corrosion plus damage to pumps, controls, and air removal device.

3.5 BOILER WATER TREATMENT

PURPOSE OF WATER TREATMENT

Water treatment is required for satisfactory operation of the boiler. It must be devised to prevent depositing of scale and to prevent corrosion from acids, oxygen and other such harmful elements that may be in the water supply. A qualified water treatment chemist should be consulted and the water systematically treated.

OBJECTIVES

The basic objectives of water treatment are:

1. Prevent the accumulation of scale and deposits in the boiler.
2. Remove dissolved gases from the water.
3. Protect the boiler against corrosion.
4. Maintain the highest possible boiler fuel efficiency.
5. Decrease the amount of boiler down time from cleaning.

WATER SOFTENER

It is highly recommended that a zeolite water softener be used for all make-up to the boiler. It is intended that this be used in addition to the chemical treatment of the boiler. Water softening removes calcium and magnesium, the primary causes of hard boiler scale.

CONTINUOUS MONITORING REQUIRED

Water treatment should be checked and maintained whenever the boiler is operating. The boiler operator should be sure that the boiler is not operating for long periods without proper water treatment. Water treatment may vary from season to season or over a period of time. Therefore, the water treatment procedure should be checked not less than four times a year, and possibly more frequently as the local water conditions may indicate.

3.6 EXTERNAL "FIRE-SIDE" CLEANING

PURPOSE

Carbon (soot) is an insulator and is corrosive. The heating surface of a boiler must be kept free from soot accumulation to keep the boiler operating at its highest efficiency and to avoid damage from corrosion.

SOOT REMOVAL

If the yearly inspection of the boiler tube surfaces reveals a build-up of either soot or rust (usually due to condensation), the tubes should be thoroughly brushed. (Tube cleaning brushes are available from Bryan Steam) To inspect and, if necessary, clean the tube surfaces and flue collector, first remove the tube access panels. Examine the exterior of the tubes for evidence of soot or rust. Using a flashlight, carefully look between the tubes. There should be an unobstructed opening between all tubes, and the top surfaces of the tube must be free from soot accumulation. Also inspect the interior of the flue collector. Brush or vacuum the soot from all surfaces. Be sure to cover atmospheric burners with a protective cover during cleaning to prevent soot from falling into them.

If the buildup of soot is appreciable, the flue gas venting system must be thoroughly inspected internally as well, and cleaned as necessary.

IMPORTANT

If either soot or condensation is apparent, a boiler service technician should be consulted. The presence of soot indicates poor combustion and possibly hazardous boiler operation. Failure to do so may result in fire, explosion potential, or asphyxiation. A combustion test and burner adjustments should be undertaken at once.

Rust on the tubes indicates that boiler-operating temperatures are too low. The set point of the boiler operating control must be no less than 130°F for natural gas or propane firing, and 170°F for oil fired boilers. Boilers equipped with outdoor reset control must also follow these limits.

3.7 SUGGESTED MAINTENANCE SCHEDULE

DAILY

1. Make visual inspection of gauges, monitors, and indicators and record readings in boiler log.
2. Make visual check of instrument and equipment settings against factory recommended specifications.
3. Check operation of float type low water cutoffs to ensure control is functioning. The lower piping connections of float type level controls should have a suitable blowdown valve piped into a proper drain. This valve should be opened periodically to allow any sludge accumulated in the control to be flushed out. On closed loop water heating systems this should not be often required. Consult manufacturer's instructions.

WEEKLY

1. On units equipped with firing rate control, verify that it is functioning correctly by adjusting control and observing if input changes accordingly.
2. Make visual inspection of igniter and pilot flame. For an atmospheric unit, confirm pilot flame is as shown in this manual (Section 1.9) and that the main burners light off correctly (smoothly) and that the flame is clean and normal. For units with a power burner, check pilot flame signal strength as specified in burner manual.
3. Check pilot and main fuel valves for correct operation. Open limit switch - make audible and visual check - check valve position indicators and check fuel meters, if supplied.
4. Confirm boiler area is free of combustible materials and that there is nothing obstructing air openings, draft hood relief openings, etc.
5. Check combustion safety controls for flame failure and flame signal strength as specified in manufacturer's instructions located at the back of this manual for atmospheric units or in the burner manual for units equipped with a power burner.
6. Check all limit controls as specified in manufacturer's manual.
7. Check float low water cutoff as described above.

MONTHLY

1. Make visual inspection of linkage and proper operation of flue, vent, stack, or outlet dampers. Check draft as specified in Section 2 of this manual.
2. Check float low water cutoff as described above.
3. For those units equipped with a power burner, check low draft, fan, air pressure and damper position interlocks as specified in burner manual.
4. Check high and low gas pressure interlocks. Refer to manufacturers instructions for correct procedure.
5. Check high and low oil pressure interlocks. Refer to manufacturers instructions for correct procedure.

ANNUALLY

1. Perform leakage tests on pilot and main gas or main oil fuel valves as specified in manufacturers instructions.
2. Check operating control, high limit, low fire start control, and low water cutoff as specified in manufacturers instructions.
3. For units equipped with power burners, check air atomizing interlock, fuel valve interlock switch, purge switch, burner position interlock, and fuel changeover control, as specified in burner manual.
4. The boiler should be checked at least yearly by the local gas utility company. Particular attention should be paid to the pilot burner safety devices. The pilot burner should be checked to ensure that prompt ignition of all burners occurs as the gas valve opens. Refer to Section 1.9.
5. The flue gas passages and the exterior surfaces of the boiler tubes should be inspected at least annually. Any accumulation of soot or debris should be thoroughly cleaned out.
6. If the yearly inspection of the boiler tube surfaces reveals a build-up of soot (carbon) or rust, the tubes surfaces should be thoroughly brushed. Failure to do so may result in fire or asphyxiation hazards.
7. The boiler pressure vessel and piping should be checked annually.
8. Check combustion safety control for pilot turndown and refractory hold-in as specified in manufacturer's instructions.

3.8 FLOAT-ACTUATED WATER LEVEL CONTROLS

Inspect float type water level controls for proper operation. Visually inspect sight glasses for evidence of scale forming residues. Refer to section 3.9 for gauge glass maintenance.

On closed steam heating systems, the float low water cutoff should be blown down by means of opening a blowdown valve on the lower connection of the cutoff once per day.

On humidification or process systems, the blowdown schedule should be based on recommendation from a water treatment and maintenance program specifically designed for the boiler.

At the annual inspection, all float type level controls should be disassembled, cleaned and inspected thoroughly. When re-installed these controls must be given an operational test.

3.9 WATER GAUGE GLASSES

INSTALLATION

Check with the maintenance supervisor and engineering for the proper glass to be used. Compare the box and the glass label or marking to ascertain that the gauge glass ratings or temperature and pressure are suitable for use on the boiler. Use new gaskets when replacing glass. The gaskets used should be the same type as those originally supplied with the boiler. Make certain that the gauge glass valves are properly aligned.

All bolts and nuts must be free running and well lubricated, preferably with a graphite type lubricant. Washers under nuts and bolt heads are desirable. DO NOT tighten while equipment is in operation.

MAINTENANCE

Inspect the gauge glass regularly for any signs of clouding or scratching. In new processes, the gauge glass should be inspected daily until the need for replacement becomes apparent. This will help establish the routine inspection cycle.

The gauge glass should be blown down daily so as to remove accumulated sediment from the valves.

INSPECTION

To examine for scratches, shine a bright concentrated light at about a 45° angle. Anything that glistens brightly should be inspected closely. Any scratch which glistens and will catch a fingernail, or crescent-shaped or star-shaped mark is cause for replacement. This is because scratches, corrosion, chips and surface damage weaken the glass. If inner surface appears cloudy or roughened, and will not respond to cleaning procedures, this is evidence of chemical attack. If severe, this is cause for replacement.

REPLACEMENT OF GLASS

Any glass that has been removed from its mounting in process boilers, regardless of the reason for removal, should be discarded and replaced with a new glass and gaskets. Used glasses may contain hidden damage and represent a safety hazard.

Be sure that the replacement glass is suitable for service conditions.

Protective shields to keep cold air, water, or falling objects from glass must be replaced.

4.0 IDLE BOILER CARE AND LAY-UP

GENERAL

Corrosion damage to boilers is often the result of improper lay-up during non-operating periods. Substantial damage can occur in only a few days if proper precautions are not taken. This damage is irreversible and will reduce boiler reliability, increase maintenance costs and eventually shorten the useful life of the boiler tubes.

Idle boilers are vulnerable to attack when air contacts untreated wet metal surfaces. To prevent corrosion, the boiler metal must be protected by either keeping the surfaces completely dry or excluding air from the boiler. Air exclusion is accomplished either by keeping the boiler completely full of water (short term lay-up) or filling the boiler with nitrogen gas (long-term lay-up). The nitrogen gas prevents air infiltration and does not react with the metal.

In addition to the corrosion damage that occurs, the metal particles that are released will form an insulating scale on the tubes when the boiler is returned to service. These corrosion products will accumulate on critical heat transfer areas of the boiler, increasing the potential for localized corrosion and over heating.

PRE-OPERATIONAL CLEANING AND LAY-UP

Proper lay-up techniques must be used on an idle boiler even if it has never been in operation. Before pre-operational lay-up, the boiler must be chemically cleaned as outlined in Section 3.2 of this manual. This is required, as noted in this section, to remove preservatives, oil and grease from the tube surfaces. Follow the short term or long term lay-up procedure as appropriate.

TAKING BOILERS OFF LINE

In operation, boiler water contains suspended solids which are held in suspension due to water circulation and the action of treatment chemicals. Unless care is exercised when draining the boiler, these suspended solids settle on the tube surfaces and will air dry to an adherent deposit, sometimes requiring chemical cleaning to remove. In addition, these deposits may be misleading regarding the effectiveness of the chemical treatment program.

PRE-SHUTDOWN PRECAUTIONS

For a period of three to seven days prior to shutdown, manual blowdown frequency should be increased. During this period, the lower conductivity limit should be below 3500 micro-mohs per centimeter. The feed of internal treatment must be increased to maintain a specific residual concentration. Continuous blowdown

(when used) should be kept to a minimum so the reduction of solids is achieved by the increased manual blowdown.

WASHDOWN

As the boiler cannot be washed immediately, the heat in the boiler may cause baking of residual sludge. The boiler should not be drained until cooled enough to prevent this. However, never leave the boiler filled with water for any extended period of time without taking measures to prevent corrosion.

LAY-UP CONSIDERATIONS

There are two basic methods of steam boiler lay-up: Wet lay up or Dry lay-up. The choice of which method should be used depends on:

- The possibility that the boiler may need to be placed in operation on short notice.
- Disposal of lay-up solutions
- Freezing potential

Wet Lay-up is recommended for relatively short outages, such as seasonal lay-up. This method has the advantage of allowing the boiler to be brought on line with short notice. But it can pose problems if there is any likelihood of freezing.

Dry Lay-up is recommended for longer periods of boiler shut-down or storage. But it is practical only if boiler can be drained hot (120°F to 170°F) or if external drying can be provided.

WET LAY-UP OF STEAM BOILERS - SHORT TERM

In the wet lay-up procedure, the boiler is to be filled with chemically treated water and sealed to prevent air in-leakage. Nitrogen gas under slight pressure can also be used to displace air and protect the boiler surfaces from corrosion. The following steps should be taken for wet lay-up of a boiler:

1a. Procedure for operational boiler:

At least thirty minutes before the boiler comes off line, add the following chemicals:

Sodium Sulfite - 0.5 lbs. per 100 gallons water

Polymeric Sludge Dispersant - 0.1 lbs. per 100 gallons water

Caustic Soda - 0.3 lbs. per 100 gallons water

1b. Procedure for idle boiler:

If the boiler has never been on line or has been out of service for cleaning - Select the highest quality water available to fill the boiler. Steam condensate, softened water, filtered fresh water, and boiler feedwater are generally acceptable for

lay-up. Raw city water is not recommended and should not be used.

Prepare the chemical solution described in (1a) in a separate tank. Adhere to the safety precautions described in Section 3.2 of this manual. Add the concentrated lay-up solution to the boiler during the time it is being filled.

After the boiler is filled and the lay-up solution has been added, the boiler is to be operated for thirty minutes at low fire to circulate and mix the chemicals.

2. After filling, the boiler must be closed or blanked tightly. The power supply to the boiler must be cut off. Vent all air from the top of the boiler to allow complete fill with the required solution. Nitrogen gas at 5 psig may be introduced through a suitable opening to prevent air in-leakage during the lay-up period. An alternative to the nitrogen gas (see safety precautions under dry lay-up) is to install a 55 gallon drum or auxiliary vessel as shown in Figure 3.11A. This is to be fitted with a cover and filled with properly treated water. This vessel or drum should be connected to an available opening in the top of the vessel. Its purpose is to create a hydrostatic head and to allow a ready visual check of water level loss or in-leakage during the lay-up period.

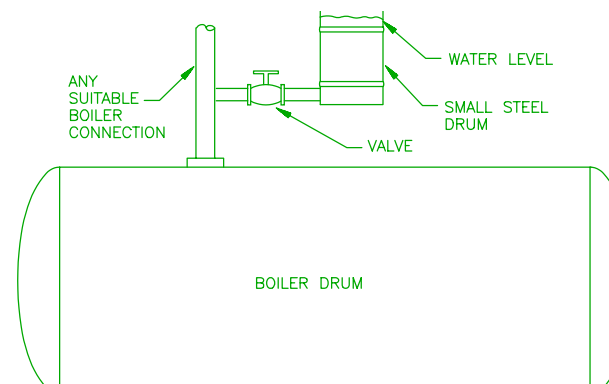

Figure 3.11A: WET LAY-UP STATIC HEAD DRUM

3. During lay-up, test the boiler weekly to assure the proper levels of sulfite and alkalinity. To do this, take a sample of the boiler water from the surface blowdown line or other high point. The test results should be:

- Sodium Sulfite 200 ppm minimum
- Phenolphthalein Alkalinity (as CaCO_3)

400 ppm minimum

If the tests indicate chemical concentration has decreased, chemical may be introduced to the boiler by putting it in the drum shown in Fig. 3.11A. Then lower the boiler water level to introduced it into the boiler. Then operate the boiler at low fire to circulate the water and mix the

chemical. Then repeat Step. 2. Pay attention to the maintenance of the valves being used to isolate the boiler to prevent leakage and resultant dilution of the lay-up solution.

ALTERNATE METHOD

An alternate wet lay-up method is to pipe clean continuous blowdown water from a properly treated boiler into any convenient bottom connection on the idle boiler, allowing the water to flow through the boiler and out the top (through any convenient top opening) to the sewer. This method will insure a continuous, complete fill with warm, properly treated water. It also prevents in-leakage of air by keeping the boiler slightly pressurized. It may also provide enough heat to keep the fireside of the boiler dry and possibly produce adequate freeze protection.

DRY LAY-UP OF STEAM BOILERS - LONG TERM

The dry lay-up method recommended requires that the boiler be drained, dried as completely as is possible, all opening and valves closed. Nitrogen gas at 5 psig is introduced to the boiler to pressurize it and prevent air in-leakage. The success of the procedure depends on the thorough drying of the boiler metal surfaces after draining and the exclusion of air during the lay-up.

CAUTION

The use of nitrogen for blanketing is recommended in both the wet and dry lay-up procedures. Even though nitrogen in dilute quantities is non-toxic, it will not support life. Precautions must be taken before entering equipment filled with nitrogen for inspections or any other purposes. These precautions shall be as follows:

- disconnection of nitrogen supply line
- complete purging and venting of the equipment with fresh air
- testing oxygen levels inside before any attempt to enter
- all confined entry guidelines applicable to site must be followed

Appropriate caution signs shall be posted around the equipment to alert personal that nitrogen blanketing is in use. A boiler laid up dry must be tagged with information that the unit is not to be operated until the boiler is properly refilled.

1. Drain the boiler before the steam pressure falls to zero. Then pressurize with 5 psig nitrogen gas through a suitable top opening during draining. The nitrogen pressure is to be maintained through draining and subsequent storage.

An alternate method is to completely dry a clean boiler (by blowing hot dry air through the boiler) and then purge the air from the boiler and pressurize with 5 psig nitrogen. Be aware that all metal surfaces which are not completely dry are vulnerable to corrosion, particularly if oxygen is present.

2. If a boiler has been down for repairs and is to be laid up, it should be operated to pressurize with steam and then drained and pressurized with nitrogen as in step 1.

3. All connections must be blanked or tightly closed.

Note: Operating boilers must be removed from service to minimize adherence of boiler water suspended solids on boiler metal surfaces. Refer to previous instructions for boiler washdown.

RETURNING IDLE BOILER TO SERVICE

After wet lay-up

To start an idle boiler after wet lay-up, use the following procedure:

1. If the boiler was pressurized with nitrogen, disconnect the nitrogen supply source and vent the boiler.

2. Using the blowdown valve, drain the boiler partially and make up with feedwater so as to dilute the chemical residuals to operating concentration levels.

3. After the boiler water concentrations and the water level are returned to proper operating conditions, the boiler can be started in the normal manner.

After Dry Lay-Up

To start an idle boiler after dry lay-up, use the following procedure:

1. Disconnect the nitrogen supply source and vent the boiler in a safe manner - external to the building and away from air intakes. Then thoroughly purge the boiler of nitrogen with dry air.

2. The boiler was to have been cleaned before the lay up procedure. So it is necessary only to fill the boiler with properly treated water. Then proceed with start-up.

Free Manuals Download Website

<http://myh66.com>

<http://usermanuals.us>

<http://www.somanuals.com>

<http://www.4manuals.cc>

<http://www.manual-lib.com>

<http://www.404manual.com>

<http://www.luxmanual.com>

<http://aubethermostatmanual.com>

Golf course search by state

<http://golfingnear.com>

Email search by domain

<http://emailbydomain.com>

Auto manuals search

<http://auto.somanuals.com>

TV manuals search

<http://tv.somanuals.com>