

BUSH HOG®

Front End Loaders M146 / M246



OPERATOR'S MANUAL

ASSEMBLY ● OPERATION ● MAINTENANCE

CONGRATULATIONS!

You have invested in the best implement of its type on the market today.

The care you give your Bush Hog implement will greatly determine your satisfaction with its performance and its service life. We urge a careful study of this manual to provide you with a thorough understanding of your new implement before operating, as well as suggestions for operation and maintenance.

If your manual should become lost or destroyed, Bush Hog will be glad to provide you with a new copy. Order from Bush Hog, P. O. Box 1039, Selma, Alabama 36702-1039.

As an authorized Bush Hog dealer, we stock genuine Bush Hog parts which are manufactured with the same precision and skill as our original equipment. Our trained service personnel are well informed on methods required to service Bush Hog equipment, and are ready and able to help you.

Should you require additional information or assistance, please contact us.

YOUR AUTHORIZED
BUSH HOG DEALER

BECAUSE BUSH HOG MAINTAINS AN ONGOING PROGRAM OF PRODUCT IMPROVEMENT, WE RESERVE THE RIGHT TO MAKE IMPROVEMENTS IN DESIGN OR CHANGES IN SPECIFICATIONS WITHOUT INCURRING ANY OBLIGATION TO INSTALL THEM ON UNITS PREVIOUSLY SOLD.

BECAUSE OF THE POSSIBILITY THAT SOME PHOTOGRAPHS IN THIS MANUAL WERE TAKEN OF PROTOTYPE MODELS, PRODUCTION MODELS MAY VARY IN SOME DETAIL. IN ADDITION, SOME PHOTOGRAPHS MAY SHOW SHIELDS REMOVED FOR PURPOSES OF CLARITY. **NEVER OPERATE** THIS IMPLEMENT WITHOUT ALL SHIELDS IN PLACE.

M146 / M246 Front End Loader

TABLE OF CONTENTS

SECTION/PARA	PAGE	SECTION/PARA	PAGE
Warranty	2	3-13 Bucket Level Indicator Rod.....	15
Dealer Preparation Check List.....	3	3-14 Transporting.....	20
Safety Alert Symbols.....	4	3-15 Fork Lift Operation.....	20
Safety Precautions.....	5	3-16 Quick Hitch Operation.....	21
Federal Laws & Regulations	7		
I INTRODUCTION & DESCRIPTION	8	IV MAINTENANCE	22
1-1 Introduction	8	4-1 Maintenance Check List.....	22
1-2 Description.....	8	4-2 Lubrication.....	22
		4-3 Hydraulic System	
II LOADER MOUNTING & DISMOUNTING.....	10	Pressure Requirements.....	23
2-1 Preparing Tractors.....	10	4-4 Troubleshooting	23
2-2 Mounting Loader.....	10		
2-3 Dismounting Loader	12	V ASSEMBLY.....	25
III OPERATING INSTRUCTIONS.....	13	5-1 Tractor Preparation.....	25
3-1 General Safety.....	13	5-2 Tractor Ballast.....	26
3-2 Pre Operation	13	5-3 Installation.....	26
3-3 Initial Loader Operation	13	5-4 Hydraulic Hookup	26
3-4 External Loader and/or Tractor Valve.....	14	5-5 Valve Mounting M146 Small Valve	27
3-5 Loader Mounted or Tractor Mounted		5-6 Valve Mounting M146 Series Valve.....	28
Single Lever Control Handle	14	5-7 Valve Mounting M246 Small Valve	29
3-6 Loader Mounted or Tractor Mounted Two		5-8 Valve Mounting M246 Series Valve.....	30
Control Handles	14	5-9 Power Beyond Kit	31
3-7 Neutral Position	14	5-10 Mounting Bracket Eyebolt.....	32
3-8 Float Position	14	5-11 Standard Bucket & Level Indicator Rod...32	
3-9 Loader Sense Loader Valve	14	5-12 Skid Steer Quick Hitch.....	33
3-10 Loader Operation.....	15	5-13 Fork Lift Option	33
3-11 Removing Air From Hydraulic System.....	15	Safety Decals.....	34
3-12 Hose Identification	15	Torque Specifications	36

RETAIL CUSTOMER'S RESPONSIBILITY UNDER THE BUSH HOG WARRANTY

It is the Retail Customer and/or Operator's responsibility to read the Operator's Manual, to operate, lubricate, maintain and store the product in accordance with all instructions and safety procedures. Failure of the operator to read the Operator's Manual is a misuse of this equipment.

It is the Retail Customer and/or Operator's responsibility to inspect the product and to have any part(s) repaired or replaced when continued operation would cause damage or excessive wear to other parts or cause a safety hazard.

It is the Retail Customer's responsibility to deliver the product to the authorized Bush Hog Dealer, from whom he purchased it, for service or replacement of defective parts which are covered by warranty. Repairs to be submitted for warranty consideration must be made within forty-five (45) days of failure.

It is the Retail Customer's responsibility for any cost incurred by the Dealer for traveling to or hauling of the product for the purpose of performing a warranty obligation or inspection.

BUSH HOG® LIMITED WARRANTY



Bush Hog warrants to the original purchaser of any new Bush Hog equipment, purchased from an authorized Bush Hog dealer, that the equipment be free from defects in material and workmanship for a period of one (1) year for non-commercial, state, and municipalities' use and ninety (90) days for commercial use from date of retail sale. The obligation of Bush Hog to the purchaser under this warranty is limited to the repair or replacement of defective parts.

Replacement or repair parts installed in the equipment covered by this limited warranty are warranted for ninety (90) days from the date of purchase of such part or to the expiration of the applicable new equipment warranty period, whichever occurs later. Warranted parts shall be provided at no cost to the user at an authorized Bush Hog dealer during regular working hours. Bush Hog reserves the right to inspect any equipment or parts which are claimed to have been defective in material or workmanship.

DISCLAIMER OF IMPLIED WARRANTIES & CONSEQUENTIAL DAMAGES

Bush Hog's obligation under this limited warranty, to the extent allowed by law, is in lieu of all warranties, implied or expressed, **INCLUDING IMPLIED WARRANTIES OF MERCHANTABILITY AND FITNESS FOR A PARTICULAR PURPOSE** and any liability for incidental and consequential damages with respect to the sale or use of the items warranted. Such incidental and consequential damages shall include but not be limited to: transportation charges other than normal freight charges; cost of installation other than cost approved by Bush Hog; duty; taxes; charges for normal service or adjustment; loss of crops or any other loss of income; rental of substitute equipment, expenses due to loss, damage, detention or delay in the delivery of equipment or parts resulting from acts beyond the control of Bush Hog.

THIS LIMITED WARRANTY SHALL NOT APPLY:

1. To vendor items which carry their own warranties, such as engines, tires, and tubes.
2. If the unit has been subjected to misapplication, abuse, misuse, negligence, fire or other accident.
3. If parts not made or supplied by Bush Hog have been used in connection with the unit, if, in the sole judgement of Bush Hog such use affects its performance, stability or reliability.
4. If the unit has been altered or repaired outside of an authorized Bush Hog dealership in a manner which, in the sole judgement of Bush Hog, affects its performance, stability or reliability.
5. To normal maintenance service and normal replacement items such as gearbox lubricant, hydraulic fluid, worn blades, or to normal deterioration of such things as belts and exterior finish due to use or exposure.
6. To expendable or wear items such as teeth, chains, sprockets, belts, springs and any other items that in the company's sole judgement is a wear item.

NO EMPLOYEE OR REPRESENTATIVE OF BUSH HOG IS AUTHORIZED TO CHANGE THIS LIMITED WARRANTY IN ANY WAY OR GRANT ANY OTHER WARRANTY UNLESS SUCH CHANGE IS MADE IN WRITING AND SIGNED BY BUSH HOG'S SERVICE MANAGER, POST OFFICE BOX 1039, SELMA, ALABAMA 36702-1039.



Record the model number, serial number and date purchased. This information will be helpful to your dealer if parts or service are required.

MODEL NUMBER _____

MAKE CERTAIN THE WARRANTY REGISTRATION CARD HAS BEEN FILED WITH BUSH HOG/
SELMA, ALABAMA

SERIAL NUMBER _____

DATE OF RETAIL SALE _____

DEALER PREPARATION CHECK LIST

M146 & M246 LOADERS

BEFORE DELIVERING MACHINE - The following check list should be completed.
Use the Operator's Manual as a guide.

- Machine properly assembled.
- All safety decals readable. (See decal page)
- All bolts tightened to torque specifications given in torque chart.
- Machine operates properly.
- Customer has appropriate mounting kit for his tractor and loader.
- Customer has appropriate attachments for loader operations. (Buckets for lifting loose materials; bale spear for lifting round bales; fork lift for lifting palletized material)

CAUTION

**IT IS RECOMMENDED THAT TRACTOR BE
EQUIPPED WITH ROLLOVER PROTECTIVE SYS-
TEM (ROPS) AND SEAT BELT BE USED FOR ALL
LOADER OPERATIONS.**

- Operators manual has been delivered to owner and he has been instructed on the safe and proper use of the front end loader.

Dealer's Signature _____

THIS CHECK LIST TO REMAIN IN OPERATOR'S MANUAL

It is the responsibility of the dealer to complete the procedures listed
above before delivery of this implement to the customer.

Safety Alert Symbol



This Safety Alert Symbol means: “**ATTENTION! BECOME ALERT! YOUR SAFETY IS INVOLVED!**”

This symbol is used to call attention to safety precautions that should be followed by the operator to avoid accidents. When you see this symbol, carefully read the message that follows and heed its advice. Failure to comply with safety precautions could result in death or serious bodily injury.

Safety Signs *Signal Words*

The signal words **DANGER, WARNING, AND CAUTION** are used on the equipment safety signs. These words are intended to alert the viewer to the existence and the degree of hazard seriousness.

 **DANGER**

White letters on **RED**

This signal word indicates a potentially hazardous situation which, if not avoided, will result in death or serious injury.

 **WARNING**

Black letters on **ORANGE**

This signal word indicates a potentially hazardous situation which, if not avoided, could result in death or serious injury

It may also be used to alert against unsafe practices.

 **CAUTION**

Black letters on **YELLOW**

This signal word indicates a potentially hazardous situation exist which, if not avoided, may result in minor or moderate injury.

It may also be used to alert against unsafe practices.

IMPORTANT SAFETY PRECAUTIONS

This symbol is used to call attention to safety precautions that should be followed by the operator to avoid accidents. When you see this symbol, carefully read the message that follows and heed its advice. Failure to comply with safety precautions could result in death or serious bodily injury.



In addition to the design and configuration of equipment, hazard control and accident prevention are dependent upon the awareness, concern, prudence and proper training of personnel in the operation, transport, maintenance and storage of equipment. Lack of attention to safety can result in accident, personal injury, reduction of efficiency and worst of all—loss of life. Watch for safety hazards and correct deficiencies promptly. Use the following safety precautions as a general guide to safe operations when using this machine. Additional safety precautions are used throughout this manual for specific operating and maintenance procedures. Read this manual and review the safety precautions often until you know the limitations.

THE TRACTOR

1. Read the tractor operator's manual to learn how to operate your tractor safely. Failure to do so could result in serious injury or death and equipment damage.
2. It is recommended that tractor be equipped with Rollover Protective System (ROPS) and a seat belt be used for all loader operations.
3. Add wheel ballast or rear weight for stability.
4. Move wheels to the tractor manufacturer's widest recommended settings to increase stability.
5. For better stability, use tractor with wide front axle rather than tricycle front wheels.
6. Move and turn the tractor at low speeds.
7. Stop tractor engine, place transmission in park (or neutral), engage parking brake, lower loader arms to ground, cycle all hydraulic controls to relieve pressure, allow machine moving parts to stop, remove ignition key to prevent unauthorized person from starting engine before dismounting tractor or servicing, repairing, or making adjustments to the equipment.
8. Wear personal protective equipment (PPE), such as, but not limited to, protection for eyes, ears, lungs, head, hands and feet when operating, servicing, or repairing equipment. Avoid wearing loose clothing or jewelry that may catch and entangle on equipment moving parts.

THE LOADER

1. Read the loader operator's manual to learn how to operate your loader safely. Failure to do so could result in serious injury or death and equipment damage.
2. Become familiar with all the machine's controls and all the caution, warning and danger decals affixed to the machine before attempting to start or operate.
3. Improper use of a loader can cause serious injury or death.
4. Do not lift or carry anybody on the loader or in the bucket or attachment.
5. Never allow anyone to get under the loader bucket or reach through the booms when the bucket is raised.
6. Do not walk or work under a raised loader bucket or attachment unless it is securely blocked or held in position.
7. Avoid overhead wires and obstacles when loader is raised. Contacting electrical lines can cause electrocution.
8. Make sure all parked loaders on stands are on a hard, level surface.
9. Use a piece of cardboard or wood rather than hands and wear eye protection when searching for hydraulic leaks. Escaping hydraulic oil under pressure can penetrate skin. If oil is injected into skin, it must be surgically removed within a few hours by a doctor or gangrene may result.

SAFETY PRECAUTIONS CONTINUED

10. Before disconnecting hydraulic lines, relieve all hydraulic pressure.
11. Do not tamper with the relief valve setting. The relief valve is pre-set at the factory. Changing the setting can cause overloading the loader and tractor and serious operator injury may result.
12. Always wear safety goggles when repairing or servicing machine.
13. When servicing or replacing pins in cylinder ends, buckets, etc., always use a brass drift and hammer. Failure to do so could result in injury from flying fragments.
14. Replace damaged or illegible safety decals. See decal page for required decals.
15. Do not modify or alter or permit anyone else to modify or alter the loader, any of its components or any loader function without first consulting your local dealer.

OPERATING THE LOADER

1. It is the loader owner's responsibility to instruct and have a person read operator's manual, safety decals and become familiar with machine controls before allowing them to operate loader.
2. Do not allow children to operate the loader.
3. Before starting or operating the equipment, make a walk around inspection and check for loose or damaged components. Correct any deficiency before starting.
4. Keep the area of operation clear of all persons, particularly small children. The operator should cease operation whenever anyone comes within the operating area.
5. Operate the loader from the "Operator's Seat Only."
6. Exercise caution when operating the loader with a raised loaded bucket, fork, or large round hay bale handling attachments.
7. Avoid loose fill, rocks and holes. They can be dangerous for loader operation or movement.
8. Be extra careful when working on inclines.
9. Allow for the loader length when making turns.
10. Stop the loader arms gradually when lowering or lifting.
11. Use caution when handling loose or shiftable loads.
12. Carry loader arms at a low position during transport.
13. Lower loader arms, stop engine, and lock brakes before leaving the tractor seat.
14. Operate the loader controls only when properly seated at the controls.
15. Do not use loader for handling large, heavy objects such as logs, oil drums, etc.
16. Handling large, heavy objects is dangerous due to:
 - *Possibility of rolling the tractor over.
 - *Possibility of upending the tractor.
 - *Possibility of the object rolling or sliding down the loader arms onto the operator.
17. Use large round hay bale handler attachment with bale retaining devices (grapples, bale spears, clamps, etc.) to handle large round hay bales. Failure to use retaining devices could allow round hay bales to roll or fall down loader boom arms onto the operator causing serious injury or death and equipment damage.

IMPORTANT FEDERAL LAWS AND REGULATIONS* CONCERNING EMPLOYERS, EMPLOYEES AND OPERATIONS.

*(This section is intended to explain in broad terms the concept and effect of the following federal laws and regulations. It is not intended as a legal interpretation of the laws and should not be considered as such).

U.S. Public Law 91-596 (The Williams-Steiger Occupational and Health Act of 1970) OSHA

This Act Seeks:

"...to assure so far as possible every working man and woman in the nation safe and healthful working conditions and to preserve our human resources..."

DUTIES

Sec. 5 (a) Each employer—

- (1) shall furnish to each of his employees employment and a place of employment which are free from recognized hazards that are causing or are likely to cause death or serious physical harm to his employees;
- (2) shall comply with occupational safety and health standards promulgated under this Act.
 - (b) Each employee shall comply with occupational safety and health standards and all rules, regulations and orders issued pursuant to this Act which are applicable to his own actions and conduct.

OSHA Regulations

Current OSHA regulations state in part: "At the time of initial assignment and at least annually thereafter, the employer shall instruct every employee in the safe operation and servicing of all equipment with which the employee is, or will be involved." These will include (but are not limited to) instructions to:

Keep all guards in place when the machine is in operation;

Permit no riders on equipment;

Stop engine, disconnect the power source, and wait for all machine movement to stop before servicing, adjusting, cleaning or unclogging the equipment, except where the machine must be running to be properly serviced or maintained, in which case the employer shall instruct employees as to all steps and procedures which are necessary to safely service or maintain the equipment.

Make sure everyone is clear of machinery before starting the engine, engaging power, or operating the machine.

EMPLOYEE TRACTOR OPERATING INSTRUCTIONS:

1. Securely fasten your seat belt if the tractor has a ROPS.
2. Where possible, avoid operating the tractor near ditches, embankments, and holes.
3. Reduce speed when turning, crossing slopes, and on rough, slick, or muddy surfaces.
4. Stay off slopes too steep for safe operation.
5. Watch where you are going, especially at row ends, on roads, and around trees.
6. Do not permit others to ride.
7. Operate the tractor smoothly - no jerky turns, starts, or stops.
8. Hitch only to the drawbar and hitch points recommended by tractor manufacturers.
9. When tractor is stopped, set brakes securely and use park lock if available.

Child Labor Under 16 Years Old

Some regulations specify that no one under the age of 16 may operate power machinery. It is your responsibility to know what these regulations are in your own area or situation. (Refer to U.S. Dept. of Labor, Employment Standard Administration, Wage & Home Division, Child Labor Bulletin #102.)

SECTION I INTRODUCTION AND DESCRIPTION

Figure 1-1 Major Components

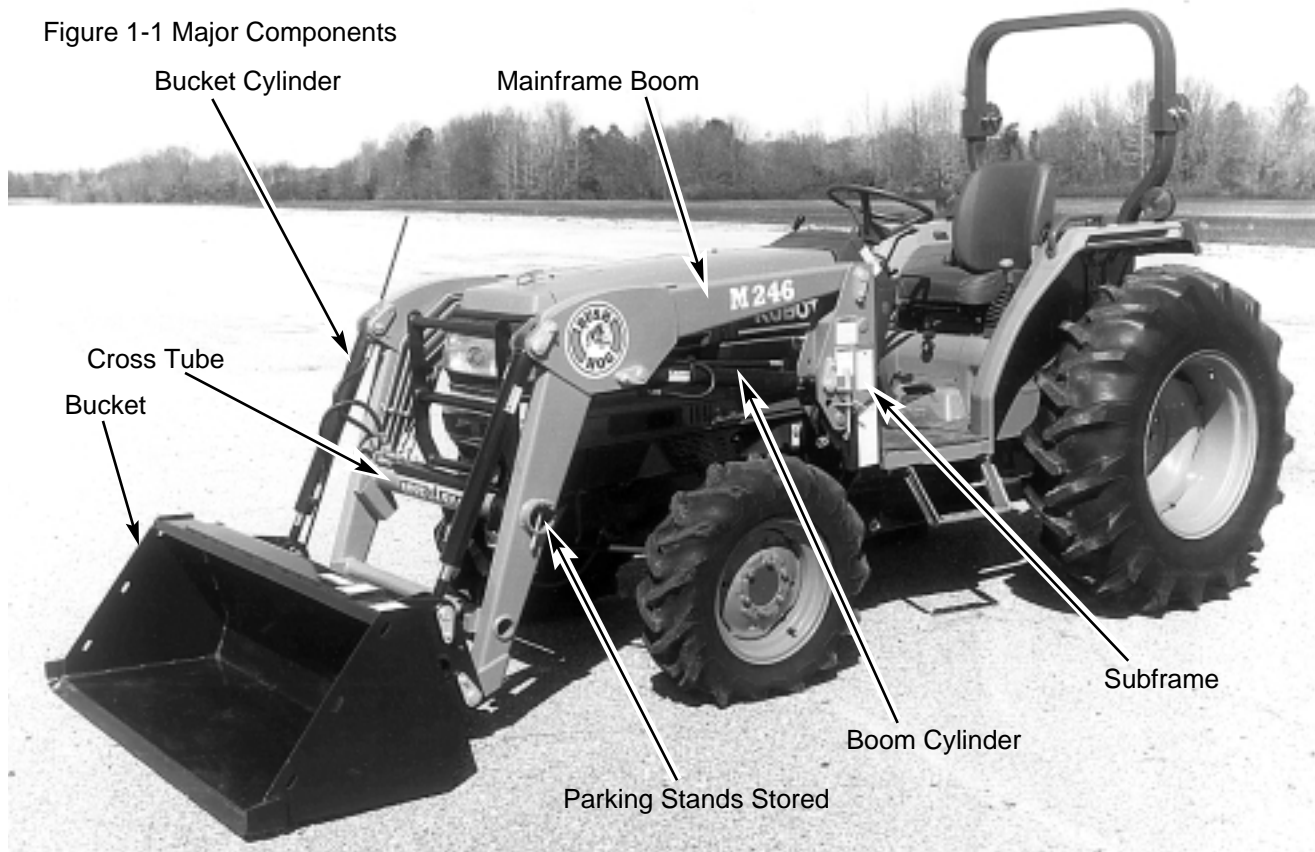

1-1 INTRODUCTION

We are pleased to have you as a Bush Hog customer. Your Front End Loader has been carefully designed to give maximum service with minimum down time. This manual is provided to give you the necessary operating and maintenance instructions for keeping your front end loader in top operating condition. Please read this manual thoroughly. Understand what each control is for and how to use it. Observe all safety precautions decaled on the machine and noted throughout the manual for safe operation of this implement. If any assistance or additional information is needed, contact your authorized Bush Hog dealer.

1-2 DESCRIPTION

Model M146 & M246 Front End Loaders are designed for two wheel and four wheel drive tractors. They come equipped with parking stands to support the loader so the tractor can be "driven in" for quick attachment and a bucket level indicator that allows the operator to gauge bucket position when the bucket cannot be seen. Available attachments include buckets for lifting loose materials and a fork lift (M246 Models only) for palletized material. All operations should be conducted within the loader limits specified in Table 1-1.

Table 1-1 TECHNICAL SPECIFICATIONS

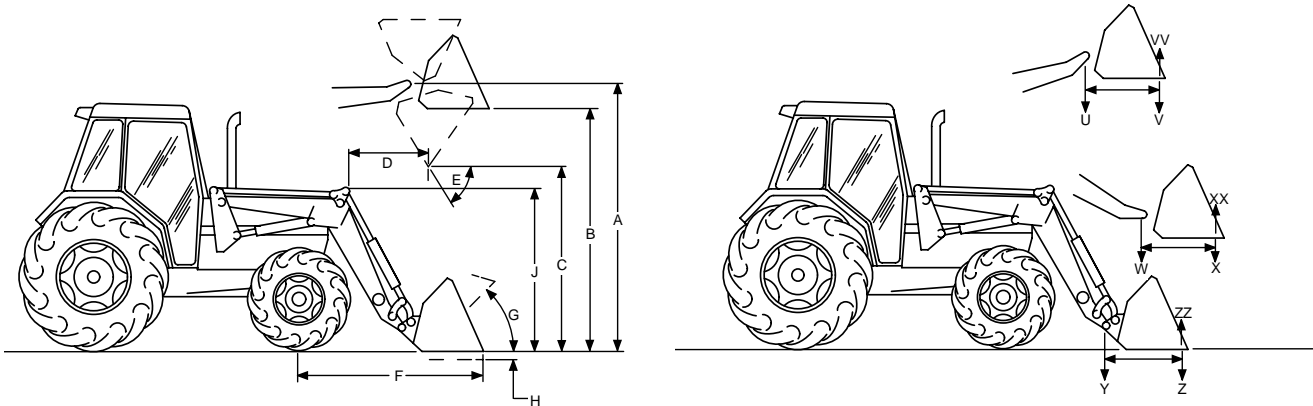

SERIES LOADER	M246	M146
A. Maximum Lift Height - Measured at Pivot Pin	103 in.	86 in.
B. Maximum Lift Height - Under Level Bucket	96 in.	81 in.
C. Clearance with Attachment Dumped 45°	77 in.	67 in.
D. Reach at Maximum Height	22 in.	23 in.
E. Maximum Dump Angle	40°	45°
F. Reach with Bucket on Ground	62 in.	54 in.
G. Maximum Rollback Angle	25°	25°
H. Digging Depth	5 in.	5 in.
J. Overall Height in Carry Position	56 in.	48 in.
U. Lift Capacity to Maximum Height - At Pivot Pin	1530 lbs.	825 lbs.
V. Lift Capacity to Maximum Height - 31.5" (M246), 19.7" (M146) Forward of Pivot Pin	880 lbs.	570 lbs.
W. Lift Capacity to 59" Height - At Pivot Pin	1730 lbs.	940 lbs.
X. Lift Capacity to 59" Height - 31.5" (M246), 19.7 (M146) Forward of Pivot Pin	1195 lbs.	710 lbs.
Y. Breakout Force - At Pivot Pin	2370 lbs.	1335 lbs.
Z. Breakout Force - 31.5" (M246), 19.7 (M146) Forward of Pivot Pin	1530 lbs.	965 lbs.
VV. Rollback Force at Maximum Height - 31.5" (M246), 19.7 (M146) Forward of Pivot Pin	1625 lbs.	1935 lbs.
XX. Rollback Force at 59" Height - 31.5" (M246), 19.7 (M146) Forward of Pivot Pin	2020 lbs.	2300 lbs.
ZZ. Rollback Force at Ground Level - 31.5" (M246), 19.7 (M146) Forward of Pivot Pin	1680 lbs.	1700 lbs.
Raising Time - Ground Level to Full Height	4 sec.	3.5 sec.
Lowering Time - Full Height to Ground	2 sec.	2.5 sec.
Bucket Dumping Time - Full Rollback to Full Dump	3 sec.	4.0 sec.
Bucket Rollback Time - Full Dump to Full Rollback	2 sec.	3.0 sec.
Tractor HP Range	20 - 30 2 & 4 WD	15 -25 2 & 4 WD
Based On Tractor Hydraulic System: Pressure Flow	2000 psi 10 gpm	1875 psi 6.0 gpm

SECTION II LOADER MOUNTING AND DISMOUNTING

2-1 PREPARING TRACTOR



TRACTORS THAT HAVE MOVABLE AXLES MUST BE SET FORWARD IN THE LONG WHEEL-BASE POSITION AS SHOWN IN FIGURE 2-1 TO PREVENT EXCESSIVE LEVERAGE BEING EXERTED ON THE TRACTOR FRAME. FAILURE TO DO SO CAN RESULT IN PERSONAL INJURY AND EQUIPMENT DAMAGE. REFER TO TRACTOR OPERATOR'S MANUAL FOR ABOVE PROCEDURES AND SPECIFICATIONS FOR YOUR TRACTOR.

- A. Check air pressure in tractor tires to be sure it is adequate for heavy loads.
- B. Add rear wheel weights, fluid in tires, or equivalent to provide sufficient tractor stability.
- C. It is recommended that tractor wheels be moved to the widest settings.
- D. Check tractor hydraulic oil reservoir to be sure it is full.
- E. Refer to your tractor operator's manual for above procedures and specifications for your tractor.

2-2 MOUNTING LOADER

To aid in mounting and dismounting loader, apply a small amount of grease, if needed, to each loader bracket in area of top receiver and guide. Figure 2-2.

- A. Slowly drive tractor to a position where the hoses can be connected to the quick couplers. Stop the engine. (Figure 2-3) Connect the loader hydraulic hoses to the correct couplers.
- B. Retract Loader Lift Cylinders.

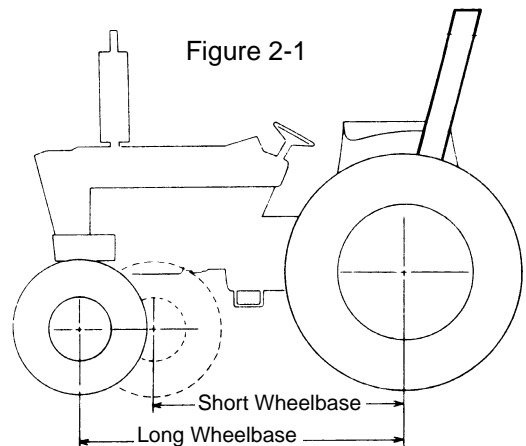

Figure 2-2 Apply Grease To These Areas

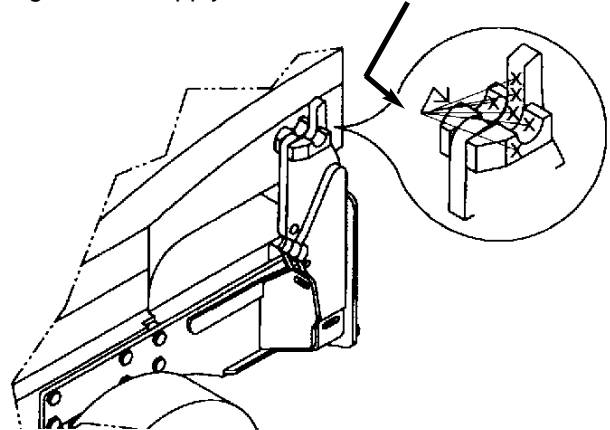
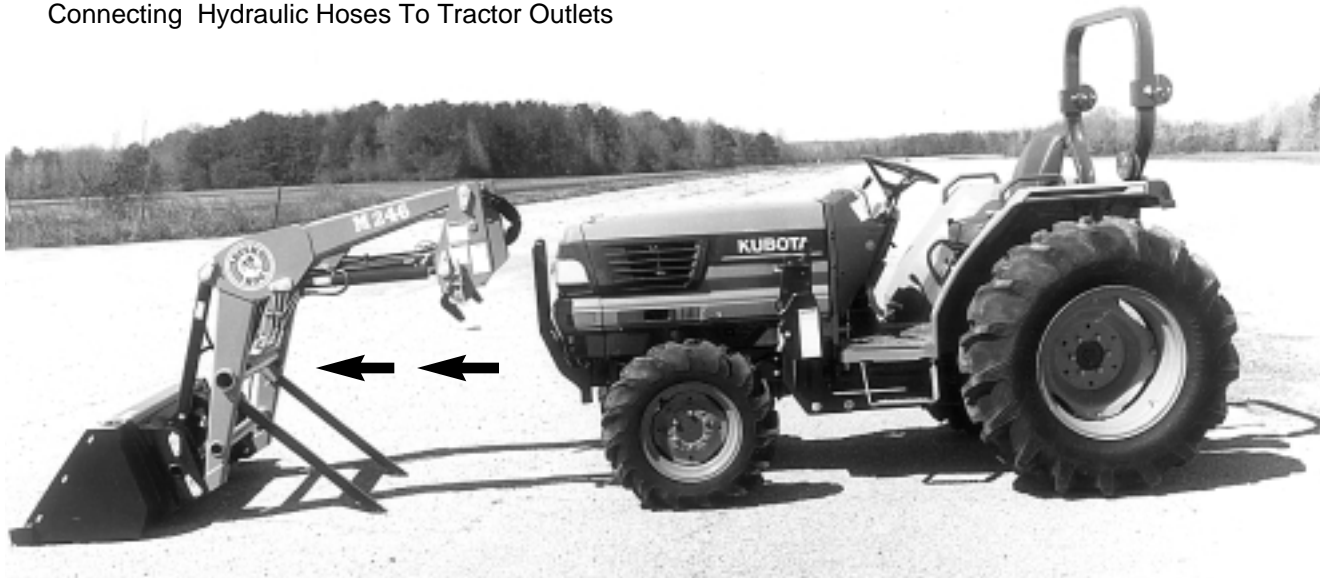
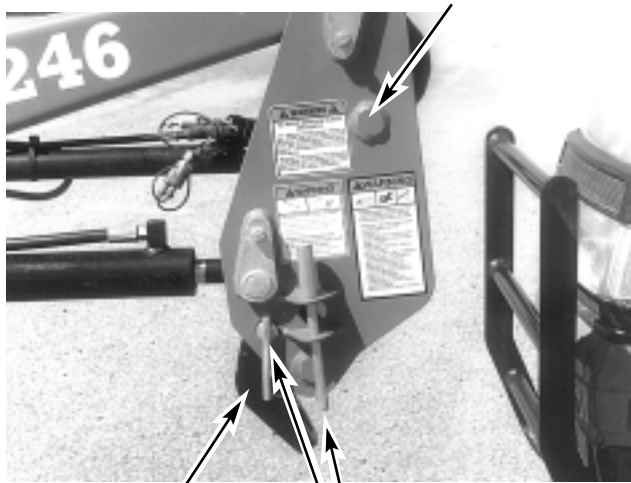

Figure 2-3 Drive In Close Enough To Allow Connecting Hydraulic Hoses To Tractor Outlets



C. Check that lift cylinders are fully retracted. Figure 2-3. Then drive tractor forward. Use bucket cylinders to position height of outer pedestal top pin. Figure 2-4.

Figure 2-4 Outer Pedestal Top Pin



Clamp And Pins In Stored Position

D. Align outer pedestal top pin with mounting bracket guide post on both sides. (Figures 2-2, & 2-4) Make sure loader is centered right to left on both brackets.

E. Extend the bucket cylinders to lower the pedestal top pins into mounting bracket receivers on both sides. Figure 2-5

Figure 2-5 Loader Installed With All Pins In Working Position



F. Extend lift cylinders slowly making sure loader is seated completely in mounting bracket top and bottom receivers. Retract bucket cylinder until bucket is approximately 1/2" off ground.

G. Remove lockwasher, quick attach nut, and self storing tool from holder. Remove quick pin and clamp from storage position. Place clamp and quick pin in working position. Install quick attach nut and lockwasher to eyebolt using self storing tool. Store self storing tool in holder. Figures 2-6 & 2-7.

Figure 2-6 Eyebolt

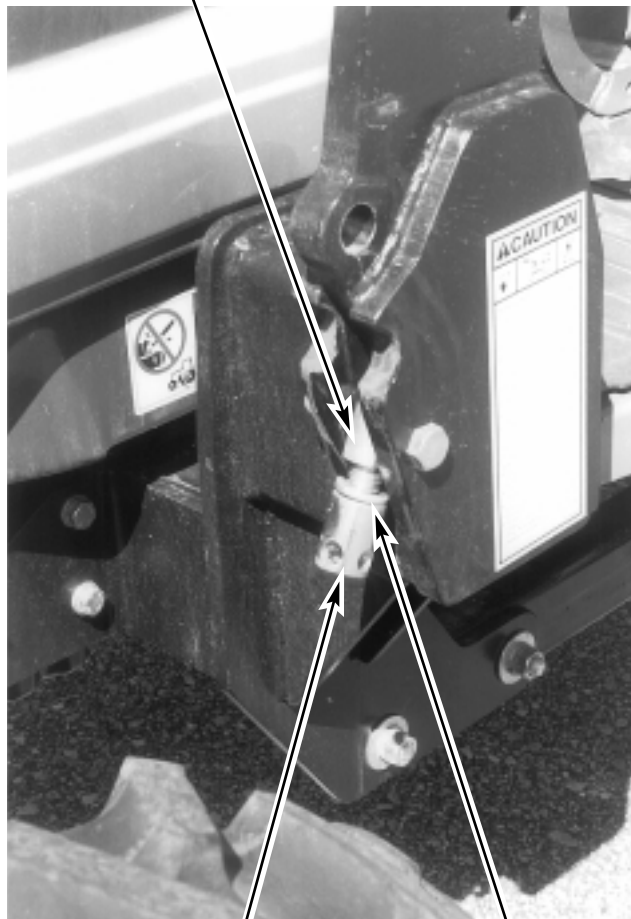

Quick Attach Nut

Lockwasher

Figure 2-7 Clamp Installed In Working Position Tightening Quick Attach Nut Using Self Storing Tool



IMPORTANT

Each time after mounting the loader, operate loader for a short period of time, then retighten the quick attach nuts. Check nuts for tightness during normal maintenance

H. Remove parking stands from the parked position and return them to their storage positions in the cross tube. Secure parking stands in the storage position by using pins. Figure 2-8.

Figure 2-8 Parking Stands

Preparing To Store Stands

Stands In Stored Position

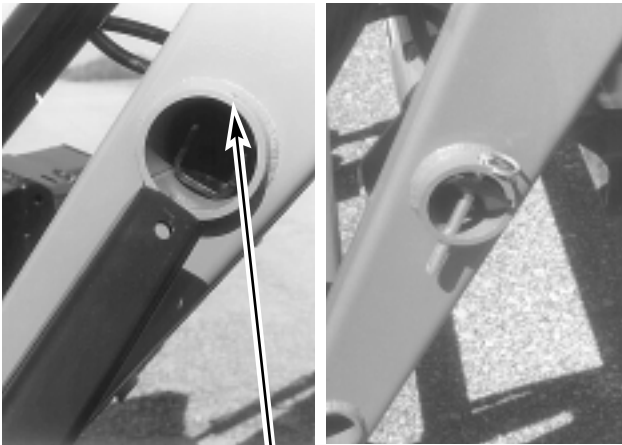

Pin Through Cross Tube Will Secure Stands In Place

I. Lower loader to ground and secure loader hydraulic hoses in a protected area.

IMPORTANT

To avoid hydraulic hose damage, be alert and make sure hoses do not catch on tractor and/or loader during mounting or dismounting.

2-3 DISMOUNTING LOADER

CAUTION

ALWAYS PARK LOADER WITH MATERIAL BUCKET OR AUTHORIZED BUSH HOG ATTACHMENT ATTACHED TO THE LOADER.

CAUTION

BEFORE LEAVING THE TRACTOR SEAT, LOWER ATTACHMENT OR LOADER BOOM TO GROUND, STOP ENGINE, LOCK BRAKES, RELIEVE HYDRAULIC PRESSURE, AND REMOVE KEY.

CAUTION

DO NOT STAND, WALK, OR WORK UNDER A RAISED LOADER OR ATTACHMENT UNLESS IT IS SECURELY BLOCKED OR HELD IN POSITION. ACCIDENTAL MOVEMENT OF A CONTROL LEVER/LEVERS OR LEAKS IN THE HYDRAULIC SYSTEM COULD CAUSE THE LOADER TO DROP, OR ATTACHMENT TO DUMP, CAUSING SEVERE INJURY.

CAUTION

DO NOT ALLOW BYSTANDERS IN LOADER AREA.

IMPORTANT

Never allow weight of tractor to be placed on parking stands when mounting or dismounting loader.

A. Position the loader on a hard level surface. The more level the surface, the easier the loader is to mount and dismount.

B. Raise loader, dump bucket over, and then lower loader so that bucket cutting edge is approximately 1/2" off of ground.

C. Remove parking stands from their storage positions in the boom crosstube as shown in Figure 2-8.

D. Position parking stands in attaching brackets on inside of each loader arm and secure. Figure 2-9.

Figure 2-9 Parking Stands Installed

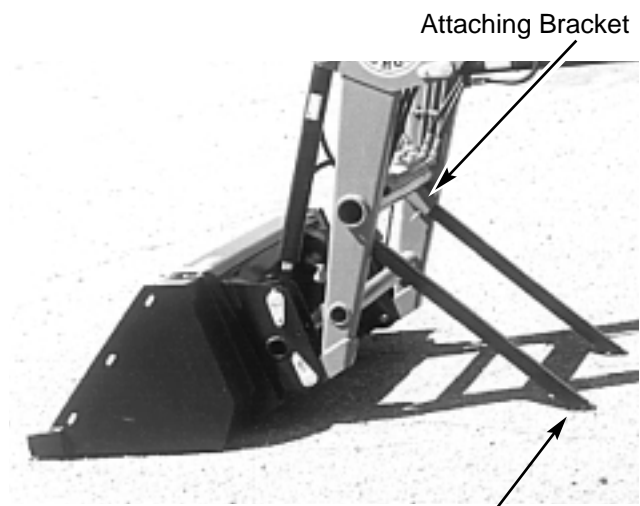

Parking Stands With Flat Side Down

E. Dismounting procedures will be the reverse of the mounting procedure. Refer to Figures 2-3 -- 2-7. Remove self storing tool from holder. Remove quick attach nut and lockwasher from eyebolt using self storing tool. Remove quick pin and clamp from working position. Place clamp and quick pin in storage position. Store lockwasher, quick attach nut, and self storing tool in holder.

F. Rollback bucket slightly while lowering loader boom down until the parking stands make firm contact with ground. Dump bucket until bucket touches the ground.

NOTE

Driving the tractor forward slowly while positioning loader will allow parking stands to contact ground firmly.

G. Retract loader lift cylinders

H. Slowly rollback bucket while driving slightly forward with tractor. Doing this will allow mounting brackets to guide loader as loader is being parked off of tractor.

I. Rollback bucket completely. Make sure all loader components clear tractor. Stop the tractor engine and then work valve control lever/levers to relieve hydraulic fluid pressure in lines. Refer to tractor operator manual for additional information.

J. Disconnect loader hoses from quick couplers. Start tractor and slowly back tractor away from loader. Figure 2-10.

IMPORTANT

To avoid hydraulic hose damage, be alert and make sure hoses do not catch on tractor and/or loader during mounting or dismounting.



WARNING

MAKE SURE PARKED LOADER IS ON A HARD LEVEL SURFACE. ENGAGE ALL SAFETY DEVICES TO PREVENT LOADER FROM FALLING AND BEING DAMAGED OR INJURING SOMEONE. DO NOT REPAIR LOADER IF IT IS NOT MOUNTED ON THE TRACTOR. LOSS OF HYDRAULIC FLUID OR REMOVAL OF PARTS COULD CAUSE LOADER TO COLLAPSE RESULTING IN INJURY.

Figure 2-10 Backing Tractor Away From Loader

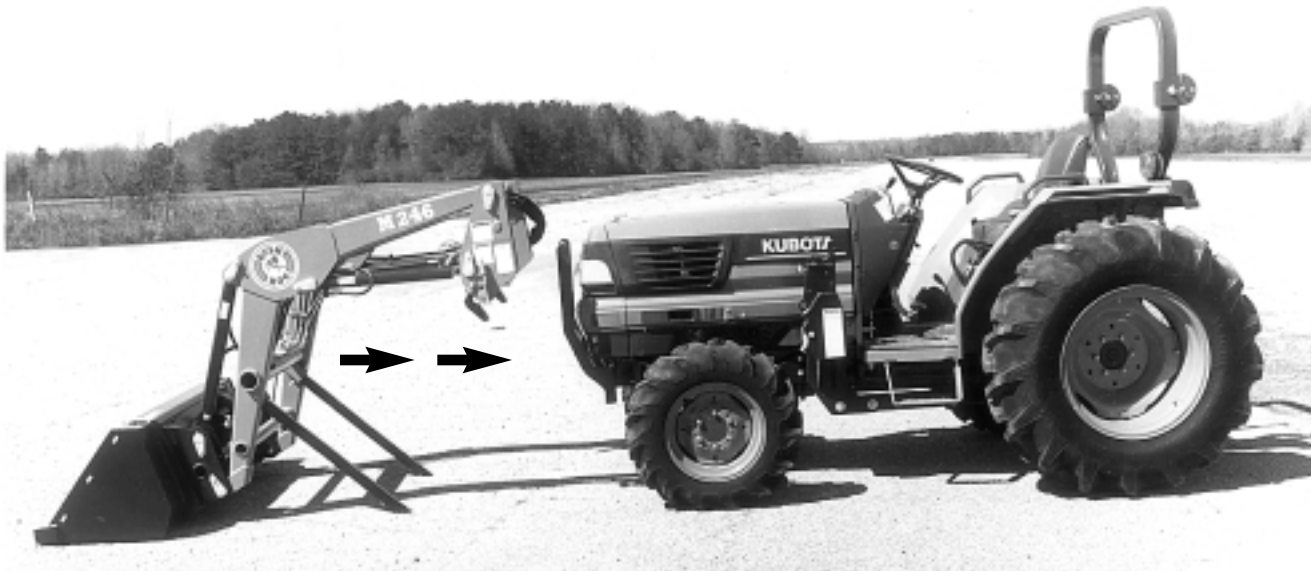

SECTION III OPERATING INSTRUCTIONS

3-1 GENERAL SAFETY

Only qualified people familiar with this operator's manual should operate this machine. Operator should wear hard hat, safety glasses, and safety shoes. The operator should read, understand and practice all safety messages shown on the caution, warning and danger decals affixed to the loader to avoid serious injury or death. It is recommended that tractor be equipped with Rollover Protective System (ROPS) and a seat belt be used. Check for ditches, stumps, holes or other obstacles that could upset tractor or damage loader. Always turn off tractor engine, set parking brake, and lower loader to ground before leaving tractor operator's seat.

3-2 PRE-OPERATION

IMPORTANT

Do not extend bucket cylinders without bucket or quick hitch attachment installed on loader. Failure to follow these instructions could cause bucket cylinder damage and will void loader warranty.

NOTE

Check the tractor hydraulic fluid reservoir and fill, if required.

3-3 INITIAL LOADER OPERATION

NOTE

Keep engine speed at low idle during the initial loader operation.

⚠ WARNING ⚠

ESCAPING HYDRAULIC FLUID UNDER PRESSURE CAN HAVE SUFFICIENT FORCE TO PENETRATE SKIN, CAUSING SERIOUS PERSONAL INJURY. BEFORE APPLYING PRESSURE TO SYSTEM, BE SURE ALL CONNECTIONS ARE TIGHT AND THAT LINES, TUBES, AND HOSES ARE NOT DAMAGED. FLUID ESCAPING FROM A VERY SMALL HOLE CAN BE ALMOST INVISIBLE. USE A PIECE OF CARDBOARD OR WOOD, RATHER THAN HANDS, TO SEARCH FOR SUSPECTED LEAKS. IF INJURED BY ESCAPING FLUID, SEE A DOCTOR AT ONCE. SERIOUS INFECTION OR REACTION CAN DEVELOP IF PROPER MEDICAL TREATMENT IS NOT ADMINISTERED IMMEDIATELY.

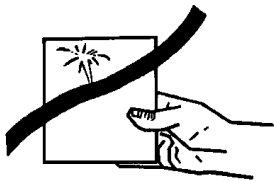

3-4 EXTERNAL LOADER AND/OR TRACTOR VALVE.

NOTE

When properly installed, the tractor remote valve or external valve control lever/levers will control the loader hydraulic circuits as described below. Refer to tractor Operator's Manual for further explanation of tractor remote control lever/levers.

IMPORTANT

Contaminants in hydraulic fluid can cause valve spools to stick. BE ALERT when operating loader and follow your tractor Operator's Manual hydraulic fluid maintenance schedule.

3-5 LOADER MOUNTED CONTROL VALVE EQUIPPED WITH SINGLE LEVER CONTROL HANDLE OR TRACTOR REMOTE VALVE EQUIPPED WITH SINGLE LEVER CONTROL HANDLE

If your loader utilizes a loader control valve equipped with single lever control handle or tractor remote valve equipped with single lever control handle, it will function as shown in Figure 3-1.

Figure 3-1

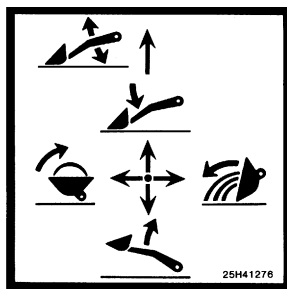

3-6 LOADER MOUNTED SERIES CONTROL VALVE EQUIPPED WITH SINGLE LEVER CONTROL HANDLE

If your loader utilizes a loader mounted series control valve equipped with single lever control handle, it will function as shown in Figure 3-2.

Figure 3-2

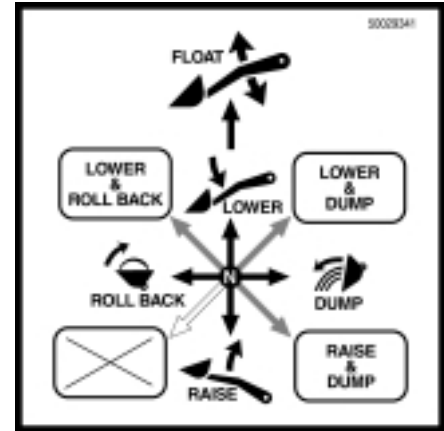

3-7 NEUTRAL POSITION

The loader external valve provided by Bush Hog has a "neutral position" which prevents movement of the loader or attachment. When the control handle is manually released from the work position, the valve spool will return to the neutral position.

3-8 FLOAT POSITION

The loader external valve provided by Bush Hog has a "float position" incorporated into the lift cylinder circuit which allows the loader to float. This float feature is important for satisfactory operation when scraping, sweeping, leveling, or any job where it is necessary to follow the contour of the surface. To activate the float position, lower the bucket or attachment and push the control handle all the way forward into detent. The valve will stay in float detent position until the operator manually pulls the control handle out of detent position to deactivate float.

3-9 LOAD SENSE LOADER VALVE.

IMPORTANT

If your loader is equipped with a load sense type control valve it may demonstrate the following operation characteristic. Attempting to raise the boom by finely feathering the control lever may actually allow the boom to lower very slowly. To prevent this from happening, move the control lever far enough to ensure that the boom raises.

3-10 LOADER OPERATION

Before operating the loader, fully raise and lower the boom three or four times. Then raise the loader bucket approximately four (4) feet above the ground and cycle the bucket two or three times. Lower the bucket or attachment to the ground. Check the tractor hydraulic fluid level and fill as required. Refer to the tractor Operator's Manual for the proper hydraulic fluid and the correct hydraulic fluid level.



BEFORE LEAVING THE TRACTOR SEAT, LOWER ATTACHMENT OR LOADER BOOM TO GROUND, STOP ENGINE, LOCK BRAKES, RELIEVE HYDRAULIC PRESSURE, AND REMOVE KEY.

IMPORTANT

Always keep the cylinders in a retracted position when the loader is not in use to guard against rust and contamination which may cause damage to the cylinder rods and hydraulic system.

3-11 REMOVING AIR FROM HYDRAULIC SYSTEM

Repeat raising and lowering the loader boom and bucket operations until all the air is removed from the system and the system responds properly.

3-12 HOSE IDENTIFICATION

Metal lines on the loader are color coded. Check loader functions. Refer to instruction sheets for hydraulic valve option on your loader.

3-13 BUCKET LEVEL INDICATOR ROD

A bucket level indicator rod (Figure 3-3), located on the loader frame, can be used to determine bucket angle. Before beginning work, observe the position of indicator rod with the bucket flat on the ground. Raise boom to several different positions and operate the bucket cylinders. Observe the indicator rod. Once familiar with the indicator rod positions, operation of the loader will be easier and more efficient.

The text and illustrations on the following pages offer suggested loader and tractor operating techniques.

Figure 3-3

Bucket Level Indicator Rod

Guide Tube



The text and illustrations that follow offer suggested loader and tractor operating techniques.



FILLING THE BUCKET

Approach and enter the pile with a level bucket.

The lift and rollback of the bucket will increase efficiency because...

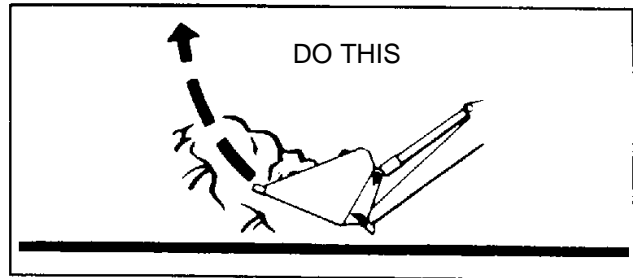
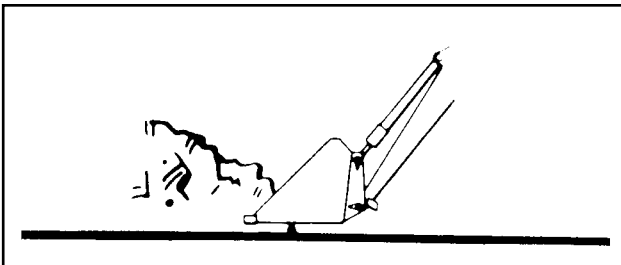

Ease lever back and toward you to lift and rollback the bucket.

... a level bucket throughout the lifting cycle resists bucket lift and increases breakaway effort.

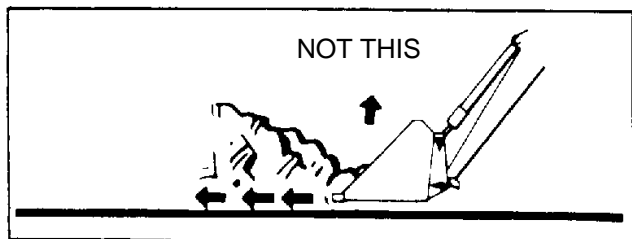
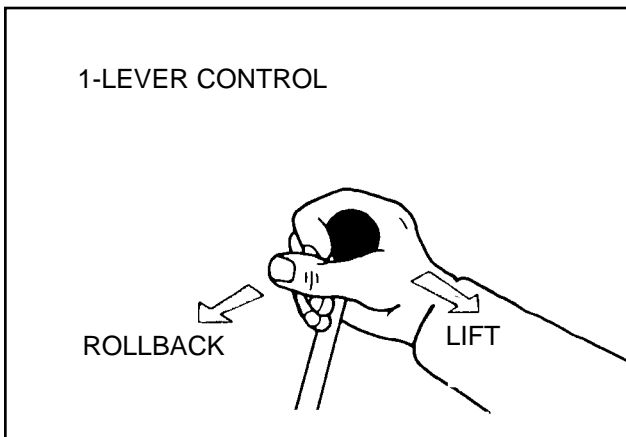

NOTE: Do not be concerned if the bucket is not completely filled during each pass. Maximum productivity is determined by the amount of material loaded in a given period of time. Time is lost if two or more attempts are made to fill the bucket on each pass.

LIFTING THE LOAD

⚠ WARNING ⚠

DO NOT LIFT OR CARRY ANYONE IN THE BUCKET OR ON ANY OTHER POSITION OF THE LOADER OR LOADER ATTACHMENT. INADVERTENT MOVEMENT OF THE LOADER OR ATTACHMENT COULD RESULT IN SERIOUS INJURY OR DEATH FROM FALLING OR CRUSHING.

⚠ CAUTION ⚠

MAKE SURE MATERIAL IN BUCKET CANNOT ROLL OUT AND DOWN ON TRACTOR WHEN BUCKET IS RAISED TO FULL HEIGHT. KEEP CLEAR OF OVERHEAD OBSTRUCTIONS SUCH AS TREES, LIMBS OR POWER LINES WHEN RAISING THE BUCKET.

When lifting the load, keep the bucket positioned to avoid spillage.

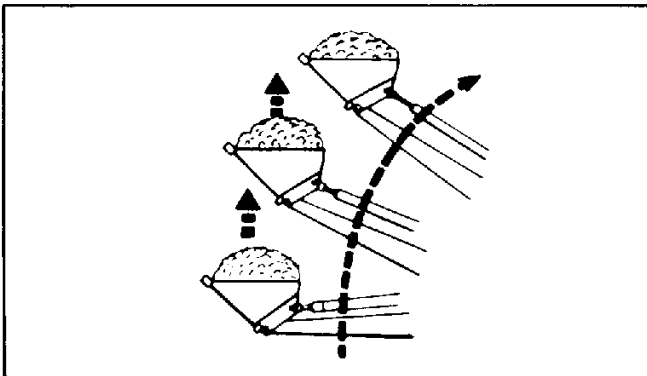

CARRYING THE LOAD

Position the bucket just below the level of the tractor hood for maximum stability and visibility, whether the bucket is loaded or empty.

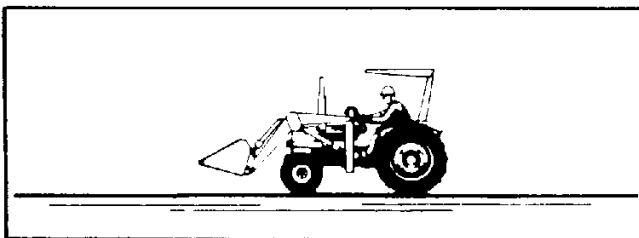

Use extreme caution when operating the loader on a slope and keep the bucket as low as possible. This keeps the bucket and tractor center of gravity low and will provide maximum tractor stability.

⚠ CAUTION ⚠

OPERATING THE LOADER ON A HILLSIDE IS DANGEROUS. EXTREME CARE IS RECOMMENDED.

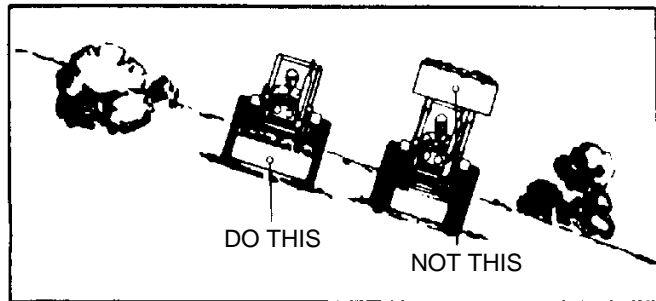

When transporting the load, keep the bucket as low as possible to avoid tipping in case a wheel drops into a rut.

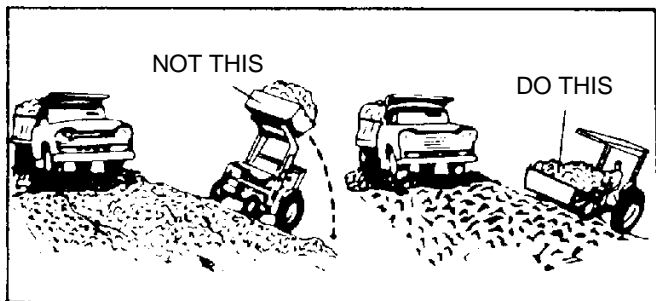

DUMPING THE BUCKET

Lift the bucket high enough to clear the side of the vehicle. Move the tractor in as close to the side of the vehicle as possible, then dump the bucket.

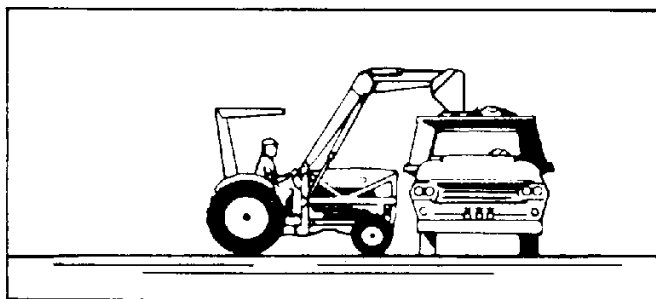

LOWERING THE BUCKET

After the bucket is dumped, back away from the vehicle while lowering and rolling back the bucket.

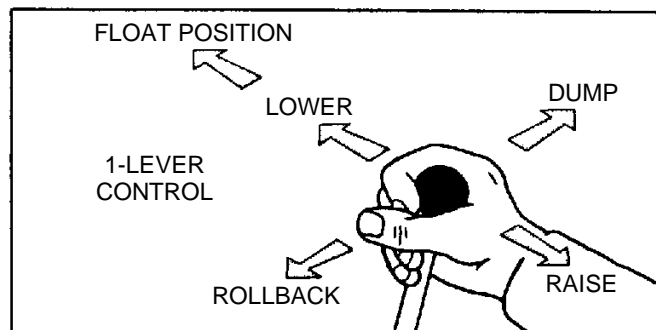

OPERATING WITH FLOAT CONTROL

During hard surface operation, keep the bucket level and put the lift control in the float position to permit the bucket to float on the working surface. If hydraulic down pressure is exerted on the bucket, it will wear faster than normal.

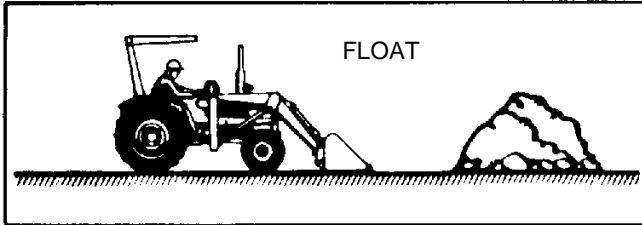

The float will also prevent the mixing of surface material with stockpile material. The float position will reduce the chance of surface gouging when removing snow or other material.

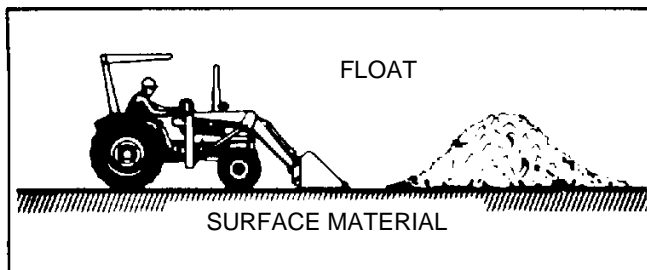

LOADING FROM A BANK

Choose a forward gear that provides sufficient ground speed for loading.

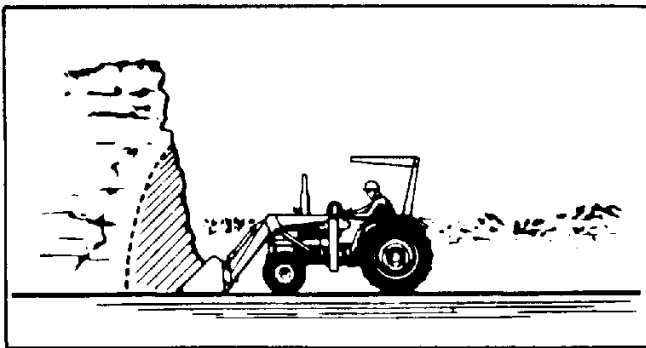

Exercise caution when undercutting high banks. Dirt slides can be dangerous. Load from as low as possible for maximum efficiency. Loader lift and breakaway capacity diminish as loading height is increased.

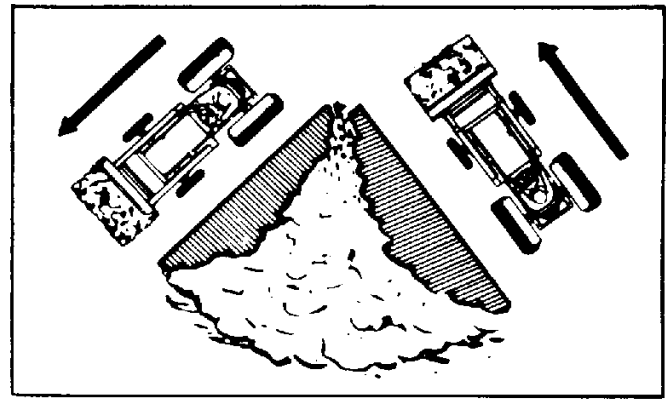

Sidecutting is a good technique for cutting down a big pile.

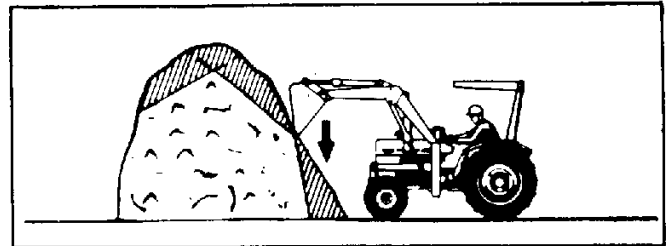

If the pile sides are too high and liable to cause cave-in, use the loader to break down the sides until a slot can be cut over the top.

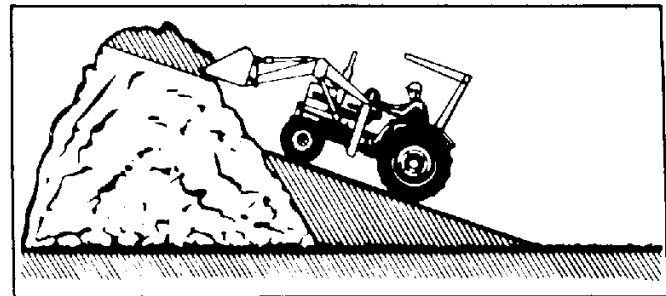

Another method for large dirt piles is to build a ramp approach to the pile.

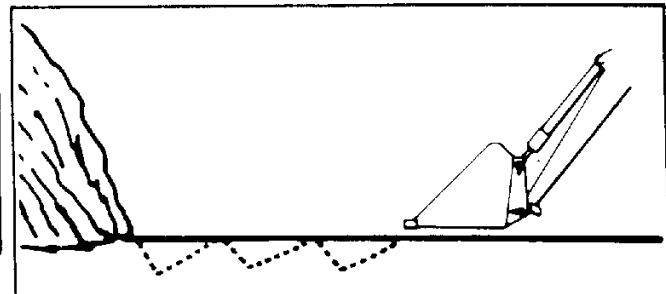

It is important to keep the bucket level when approaching a bank or pile. This will help prevent gouging the work area.

PEELING AND SCRAPING

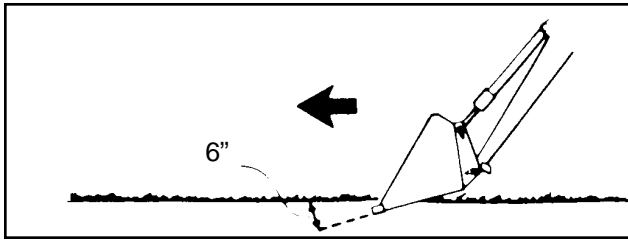

Use a slight bucket angle, travel forward, and hold the lift control forward to start the cut. Make a short, angle cut approximately 6" deep and break-out cleanly.

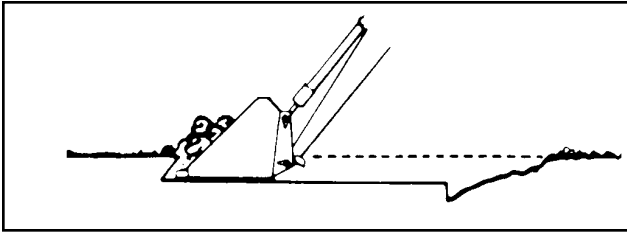

With the bucket level, start a cut at the notch approximately 2" deep. Hold the depth by feathering the bucket control to adjust the cutting lip up or down. When the front tires enter the notch, adjust the lift cylinder to maintain proper depth.

3RD CUT , 4TH CUT, ETC.

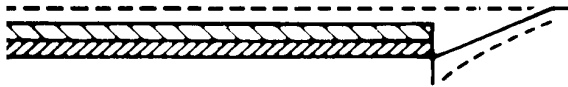

Make additional passes until the desired depth is reached. During each pass, only use the bucket control while at working depth. This will allow you to concentrate on controlling the bucket angle to maintain a precise cut.

LOADING LOW TRUCKS OR SPREADERS FROM A PILE

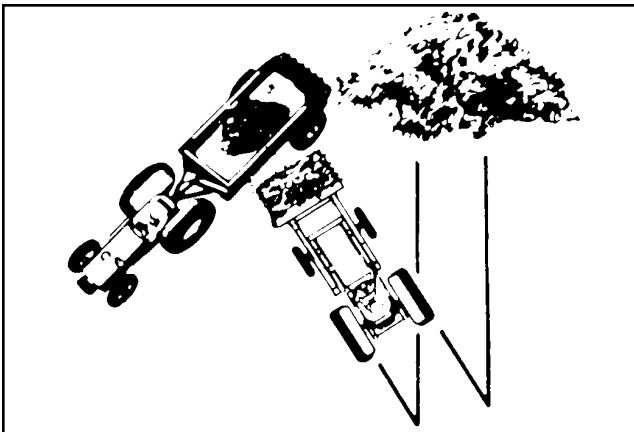

For faster loading, minimize the angle of turn and length of run between pile and spreader.

BACKFILLING

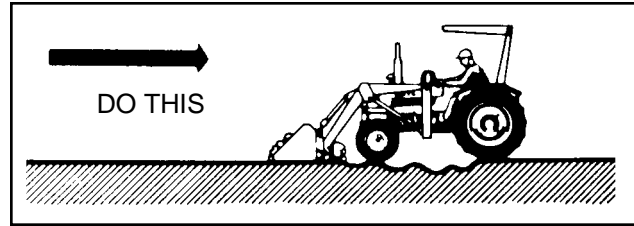

Backgrade occasionally with a loaded bucket to keep the working surface free of ruts and holes. Hold the lift control forward in **FLOAT POSITION** so **the full weight** of the bucket is scraping the ground. Use only the heel of the bucket while backgrading.

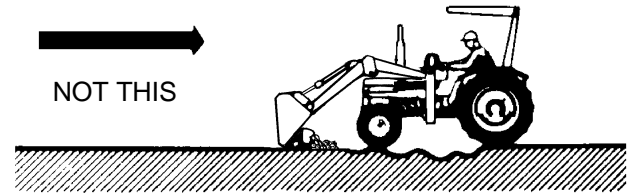

IMPORTANT: To prevent damage to cylinders:

- (1) Do not backgrade with bucket cylinders extended.
- (2) Always backgrade with valve in **float position**.

Approach the pile with a flat bucket.

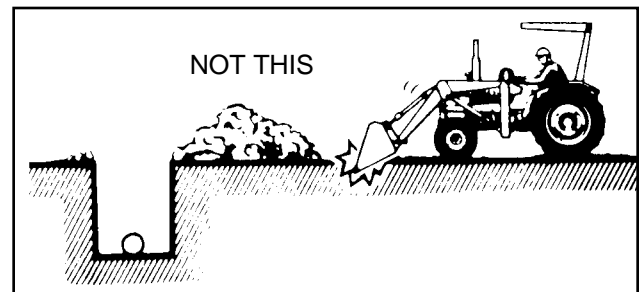
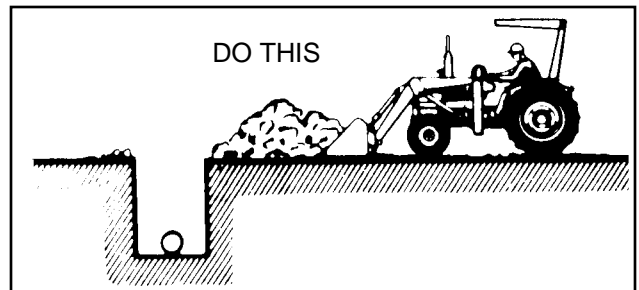

Poor methods actually move no more dirt and make it more difficult to hold a level grade.

Do not use the bucket in the dumped position for bulldozing or backgrading. This method, shown above, will impose severe shock loadings on the dump linkage, the bucket cylinder, and the tractor.

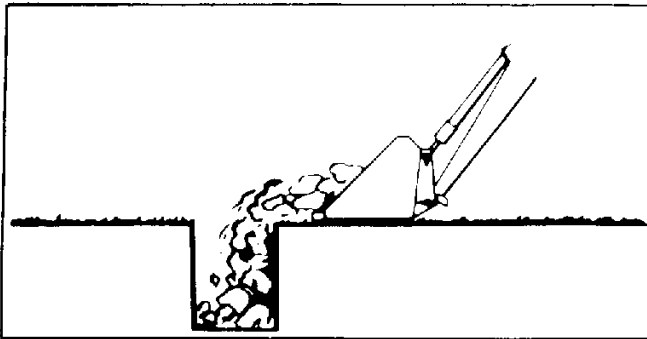

Leave dirt in the bucket because dumping on each pass wastes time.

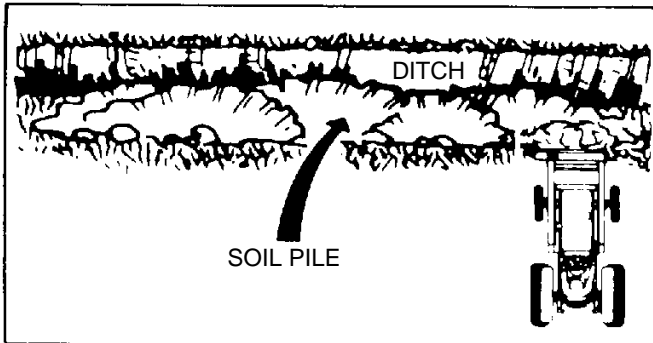

Operate at right angles to the ditch. Take as big a bite as the tractor can handle without lugging down.

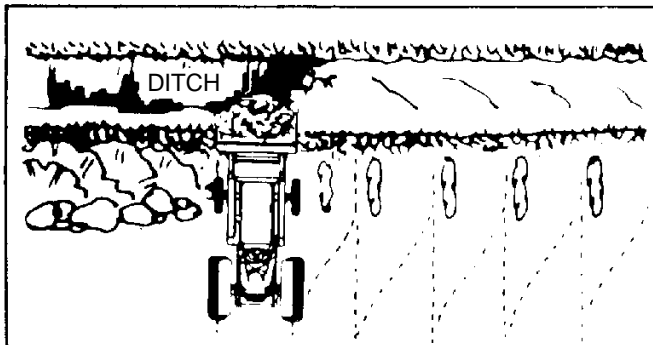

Leave dirt which drifts over the side of the bucket for final clean-up.

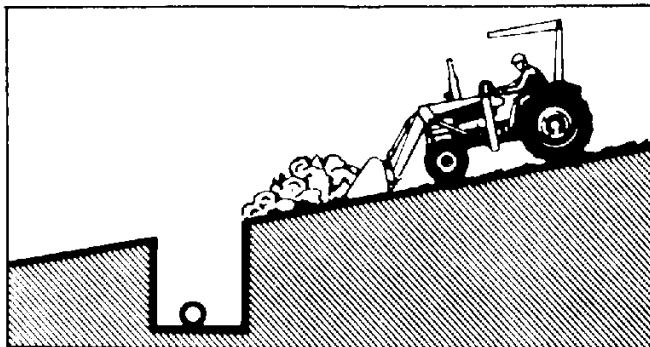

Pile dirt on the high side for easier backfilling on a slope.

HANDLING LARGE HEAVY OBJECTS

⚠ WARNING ⚠

Do not use front end loaders for handling large, heavy objects such as large, round or rectangular bales, logs and oil drums.

Handling large heavy objects can be extremely dangerous due to:

- ★ Possibility of rolling the tractor over.
- ★ Possibility of upending the tractor.
- ★ Possibility of the object rolling or sliding down the loader arms onto the operator.

3-14 TRANSPORTING

When transporting on road or highway, day or night, use tractor flashing warning lights unless prohibited by law. Carry load as low as possible maintaining adequate ground clearance and visibility. Reduce tractor ground speed when transporting a load. Take extra care when traveling over rough terrain or on slopes.

⚠ CAUTION ⚠

WHEN TRANSPORTING THE LOAD, KEEP THE BUCKET AS LOW AS POSSIBLE TO RESIST TIPPING IN CASE A WHEEL DROPS IN A RUT. THIS WILL AVOID TIPPING AND POSSIBLE INJURY.

NOTE

When loader hydraulics are disconnected from tractor the tractor hydraulic circuit must be completed. Failure to do so will result in tractor hydraulic pump damage.

3-15 FORK LIFT OPERATION (M246 ONLY)

⚠ WARNING ⚠

TO AVOID SERIOUS INJURY OR DEATH:

- ★ NEVER LIFT LARGE ROUND HAY BALES OR OTHER LOADS ON THE FORK LIFT ATTACHMENT THAT COULD ROLL BACK ONTO TRACTOR OPERATOR AREA.
- ★ NEVER USE FORK LIFT ATTACHMENT TO LIFT OR SUPPORT PEOPLE.
- ★ TRANSPORT LOADS LOW AND SLOW.
- ★ AVOID CONTACT WITH POWER LINES.

The fork lift attachment (Figure 3-4) is intended for handling palletized material. It is recommended that tractor be equipped with ROPS and seat belts. Use the loader dump cylinders to give the forks the desired tilt. Position the forks on their support rods to the desired width so that the load will be carried approximately equal on each fork. Position load as far back as possible.

Figure 3-4
Fork Lift Attachment

Adjustable Forks

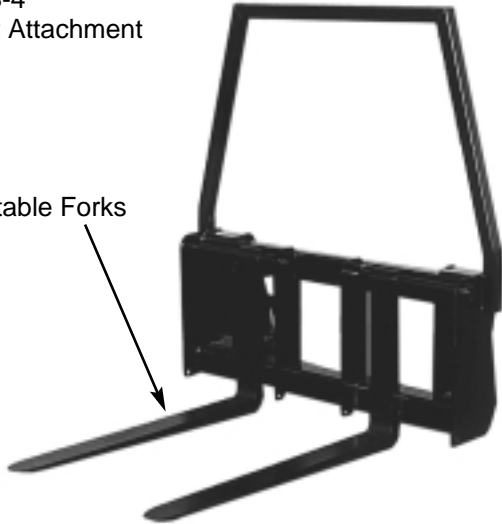

3-16 QUICK HITCH OPERATION (M246 ONLY)

The quick hitch (Figure 3-5) is designed to allow easy mounting and dismounting of skid steer attachments from loader. With attachment on flat, level surface, mount as follows:

Tilt quick hitch slightly forward at top and slowly drive into attachment.

Hook quick hitch under top cuff on attachment and lift off ground using boom cylinders only.

Tilt quick hitch backward using bucket cylinder so that bottom of attachment will swing into position.

Rotate handles downward, locking spring-loaded pins into place in slot on attachment hitch for operation.

To dismount the attachment:

Tilt quick hitch backward and rotate handles up to disengage pins. Reverse the mounting procedure.

⚠ CAUTION ⚠

ALWAYS CHECK TO INSURE THAT QUICK HITCH SPRING LOADED PIN IS IN THE LATCHED POSITION BEFORE OPERATING LOADER OR ACCIDENTAL DISENGAGEMENT OF THE ATTACHMENT COULD RESULT.

Figure 3-5 A, B, C, & D
Quick Hitch Operation

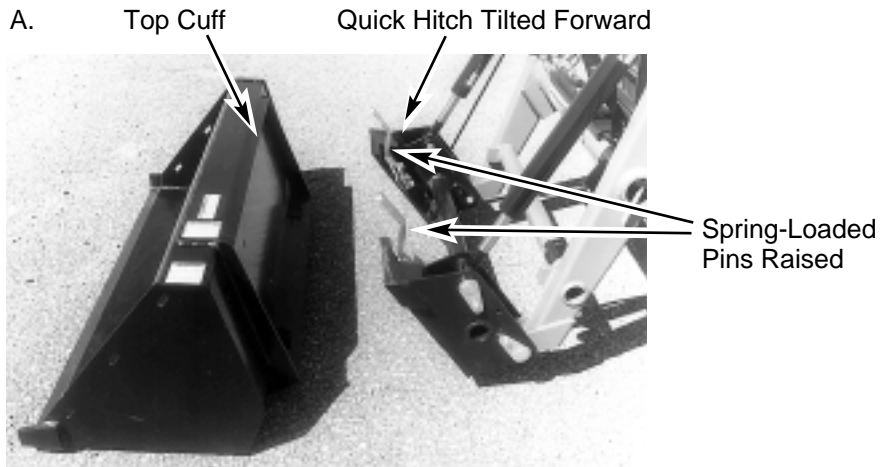

B. Drive Into Attachment



C. Raise And Roll Back Attachment



D. Lower Spring-Loaded Pins

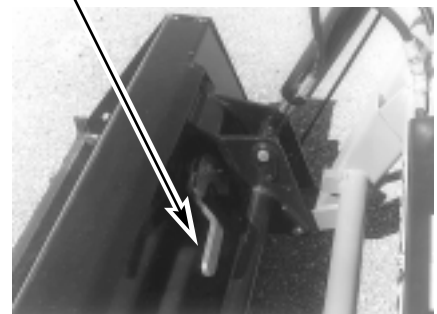

SECTION IV MAINTENANCE

4-1 MAINTENANCE CHECK LIST

Perform scheduled maintenance as outlined below. Lower machine to ground, turn off tractor, and set parking brake before doing maintenance inspections or work. All bolts should be torqued as recommended in torque chart unless otherwise indicated.



WARNING

THE LOADER CAN FALL FROM HYDRAULIC SYSTEM FAILURE. TO AVOID SERIOUS INJURY OR DEATH, SECURELY SUPPORT LOADER BEFORE WORKING UNDERNEATH.

BEFORE EACH USE

1. Inspect hydraulic lines and fittings for wear or leaks. Repair or replace if needed.
2. Inspect all pivot pins for wear. Make certain carriage bolts, lockwashers and hex nuts are installed to retain each pivot pin.
3. Check all bolts for tightness.
4. Perform BEFORE EACH USE lubrication per paragraph 4-2.
5. During operation, listen for abnormal sounds which might indicate loose parts or other damage.

AFTER EACH USE

1. Clean all debris from machine, especially cylinder rods and affixed safety decals. Replace any missing or illegible decals.
2. Inspect loader for worn or damaged components. Repair or replace before next use. Any replacement components installed during repair shall include the components' current safety decals specified by the manufacturer to be affixed to the component.
3. Store loader in a dry place.

To keep mounting kit hardware from loosening during operation, periodically check that all loader mounting kit hardware is torqued to specifications noted in torque chart, Page 36. To aid in mounting and dismounting loader, apply a small amount of grease to areas shown in Figure 4-1.

Figure 4-1 Mounting Kit

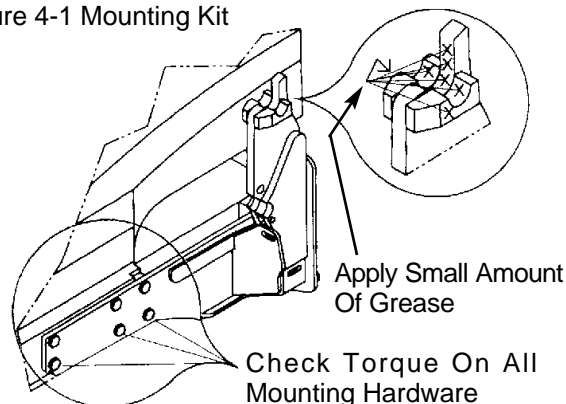

4-2 LUBRICATION (Figure 4-2)

NOTE

The multi-purpose grease referenced in this section is an NLGI grade 2 type grease.

BEFORE EACH USE

1. Boom Pivot Pins - Apply multi-purpose grease to each fitting (1 fitting each side)
2. Boom Cylinders - Apply multi-purpose grease to each fitting (2 fittings each cylinder)
3. Bucket Cylinders - Apply multi-purpose grease to each fitting (2 fittings each cylinder)
4. Bucket Pivot Pin - Apply multi-purpose grease to each fitting (1 fitting each side)
5. Hydraulic Oil - Cycle boom and bucket cylinders 2 or 3 times before each use, then check hydraulic oil level in tractor reservoir.

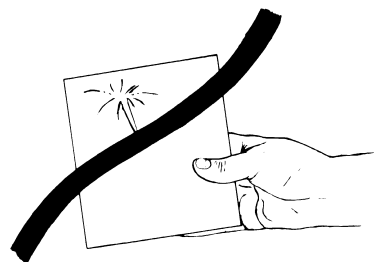

CAUTION

USE A PIECE OF CARDBOARD OR WOOD RATHER THAN HANDS AND WEAR EYE PROTECTION WHEN SEARCHING FOR HYDRAULIC LEAKS. ESCAPING HYDRAULIC OIL UNDER PRESSURE CAN PENETRATE SKIN. IF OIL IS INJECTED INTO SKIN, IT MUST BE SURGICALLY REMOVED WITHIN A FEW HOURS BY A DOCTOR OR GANGRENE MAY RESULT.

Figure 4-2 Lubrication Points

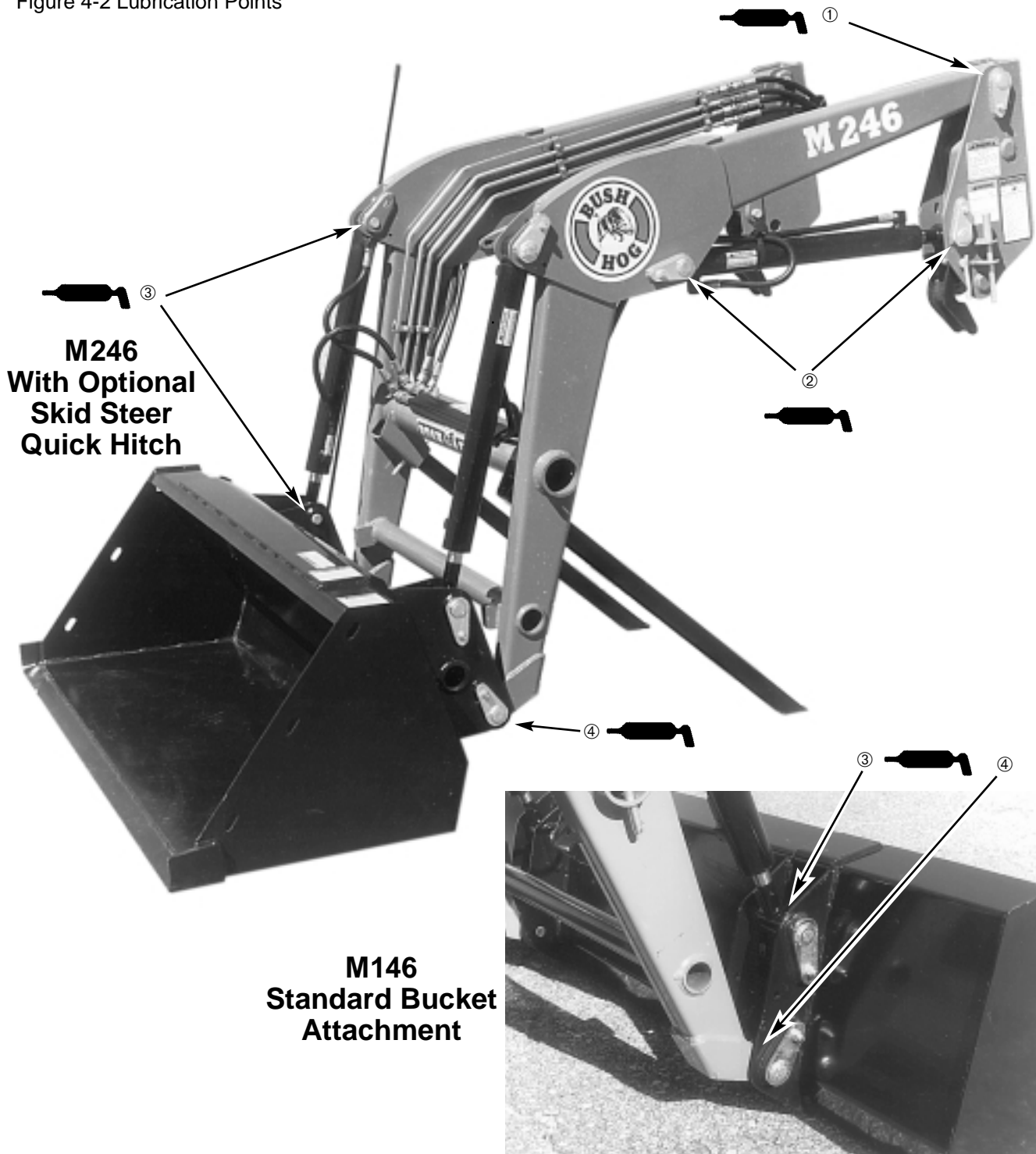

**M246
With Optional
Skid Steer
Quick Hitch**

**M146
Standard Bucket
Attachment**

4-3 HYDRAULIC SYSTEM PRESSURE REQUIREMENTS

A tractor hydraulic system pressure setting of 2500 psi is recommended for maximum efficiency and service. **Do not exceed 3000 psi as this will damage components possibly causing serious injury.** The Bush Hog control valve is pre-set at the factory and should not be adjusted.

4-4 TROUBLESHOOTING

Troubleshooting procedures are listed on page 24. If the problem cannot be solved or replacement parts are necessary, contact your authorized Bush Hog dealer. Please have ready your machine name, model number, serial number, purchase date and exact cause or description of problem.

TROUBLESHOOTING PROCEDURES

PROBLEM	POSSIBLE CAUSE	REMEDY
Loader slow and/or will not dump.	Hydraulic oil too heavy. Oil filter plugged. Hydraulic pump worn. Oil line restricted or leaking. Quick couplers not properly connected. Control valve does not shift properly. Air in hydraulic system. Cylinder leaks internally. Faulty valve.	Change to proper oil. Clean or replace filter. Repair or replace pump. Check all hoses and tubes for leaks, damage or restrictions. Replace damaged or restricted hoses or tube lines. Check connection - Replace if necessary. Inspect clean, repair or replace valve. Cycle lift cylinders and bucket cylinders several times to free system of air. Replace seals. Repair or replace valve.
Loader chatters or vibrates when raising or lowering.	Air in hydraulic system. Oil level too low.	Cycle lift cylinders and bucket cylinders. Add oil as required.
Oil leaks.	Damaged fittings or hoses. Loose connections. Worn or damaged O-ring or wiper seal in cylinder rod end. Worn or damaged O-rings in valve.	Replace damaged parts. Tighten fittings. Install a seal repair kit. Install an O-ring repair kit.
Insufficient lift capacity.	Load is greater than boom lift capacity. Internal boom cylinder leakage. Improper hydraulic valve operation.	Check loader specifications. Check tractor system. Replace any worn parts and install a seal repair kit. Repair or replace valve.
Slow leakdown.	Worn control valve. Worn cylinder piston seals.	Have authorized Bush Hog dealer replace seals. Have authorized Bush Hog dealer replace seals.
Excessive wear on bottom of bucket and wear pads.	Float position not used while operating loader.	Use float position provided on valve.
Hydraulic cylinders inoperative.	Hose from control valve improperly connected.	Refer to plumbing diagrams in Section V.
Pump operating continually on closed center tractor hydraulic system.	Hydraulic control valve relief stuck open. Hydraulic control valve relief set too low. Valve not correct for closed center operation	See your tractor manual for proper adjustment or Bush Hog dealer for loader valve. (3000 PSI is maximum pressure relief setting recommended) Install closed center plug on optional valve.
Loader lift and bucket tilt controls do not work according to decal.	Hoses improperly connected.	Refer to plumbing diagrams in Section V and correct hose connections.
Valve noisy and/or hot.	Open center control valve on closed center tractor.	Install closed center plug on optional valve.
Tractor loads/pump squeals.	Closed center control valve on open center tractor.	Install open center plug on optional valve.

SECTION V ASSEMBLY



THE FOLLOWING SAFETY PRECAUTIONS SHOULD BE THOROUGHLY UNDERSTOOD BEFORE ATTEMPTING MACHINE ASSEMBLY.

1. Do not lift heavy parts or assemblies. Use crane, jack, tackle, fork trucks, or other mechanical devices.
2. Select an area for assembly that is clean and free of any debris which might cause persons working on the assembly to trip.
3. Arrange parts to be assembled neatly in the work area and have tools or other mechanical assisting devices in easy reach.
4. Inspect all parts and assemblies thoroughly and remove any sharp edges, grease, oil, or dirt which might cause pieces to slip when handling.
5. Preview the assembly instructions in your operator's manual before proceeding further.
6. If the assembly instructions call for parts or assemblies to be blocked up, use only blocking material that is in good condition and is capable of handling the weight of the assembly to be blocked. Also insure that the blocking material is on a clean, dry surface.
7. Never put hands or any other part of body under blocked up assemblies if at all possible.
8. Always wear goggles or safety glasses when hammering, grinding or drilling metal parts.
9. If the assembly calls for welding or cutting, be sure that there are no flammable materials close at hand and that bystanders have taken necessary precautions.

AFTER COMPLETING ANY ASSEMBLY STEP, THOROUGHLY READ THE NEXT STEP IN THE ASSEMBLY INSTRUCTIONS BEFORE PROCEEDING WITH THAT STEP.

10. After completing assembly, thoroughly inspect the machine to be sure that all nuts, bolts, hydraulic fittings or any other fastened assemblies have been thoroughly tightened.

11. After completing assembly, be sure that all safety locking devices or guards are in place.
12. Before operating the machine, thoroughly read the operation section of this manual.
13. Before operating, read the maintenance section of this manual to be sure that any parts requiring lubrication, such as gearboxes, are full to avoid any possible damage.
14. Wear personal protective equipment such as, but not limited to, protection for eyes, ears, feet, hands, lungs and head when assembling the equipment. Do not wear loose clothing or jewelry that may catch on equipment moving parts.

BEFORE OPERATING THE EQUIPMENT, IF YOU HAVE ANY QUESTIONS REGARDING THE PROPER ASSEMBLY OR OPERATION, CONTACT YOUR AUTHORIZED BUSH HOG DEALER OR REPRESENTATIVE.



EQUIP YOUR TRACTOR WITH A ROPS CAB OR FRAME FOR YOUR PROTECTION. SEE YOUR TRACTOR/ROPS OPERATOR'S MANUAL FOR CORRECT SEAT BELT USAGE.

Read entire instructions before beginning to install the loader. Personal injury and machine damage may be prevented if you read and understand these instructions and special safety messages.

Any reference to right or left are as if you were in the tractor seat facing forward .

5-1 TRACTOR PREPARATION

Use front tires of equal size and maintain equal pressure in each tire. The pressure of the front tractor tires must be increased to the maximum approved pressure recommended by the tire manufacturer to compensate for additional load placed on the tires with the front end loader. Refer to your Tractor Operator's Manual. Adjust the front tires to the widest recommended setting on adjustable models for maximum stability. Front end weights must NOT be used while loader is on the tractor. Pay particular attention to "minimum tread settings" information in Installation Instructions included with your Mounting Kit.

5-2 TRACTOR BALLAST



TO HELP PREVENT ROLLOVER, USE RECOMMENDED REAR TRACTOR BALLAST AND WIDEST WHEEL SETTINGS TO MAXIMIZE STABILITY. SEE YOUR TRACTOR OPERATOR'S MANUAL FOR RECOMMENDATIONS.

Tractor weight bracket may be left in place on certain tractor models with loader mounted. Front tractor weights can only be used when the loader is parked. Weights must be removed before remounting loader or serious damage will occur to loader or tractor front axle due to excessive weight.

The use of adequate rear counterweight to counterbalance for maximum loader capacity is required for safe loader operation. Weight added to the rear of the tractor provides better traction and easier, more efficient loader operation.

IMPORTANT

Do not exceed the maximum load capacity of the tires on your tractor. Refer to the Tire and Wheel Specifications in your Tractor Operator's Manual for more information.

IMPORTANT

This loader has both standard and metric fasteners. Verify that the proper fasteners are placed in the correct locations. Do not tighten any bolts firmly until all components are attached onto the tractor.

5-3 INSTALLATION



TO AVOID SERIOUS INJURY OR DEATH: READ BEFORE CUTTING BANDS OR REMOVING ATTACHING STRAPS. THE LOADER MAY SHIFT DURING SHIPPING AND HANDLING, MAKING IT UNSTABLE ON THE PALLET. SUPPORT LOADER WITH AN OVERHEAD HOIST OR OTHER SUITABLE MEANS PRIOR TO REMOVING BANDS OR ATTACHING STRAPS SECURING LOADER TO PALLET. FAILURE TO DO SO COULD RESULT IN ACCIDENTAL TIP-OVER OF THE LOADER THAT COULD CAUSE SERIOUS INJURY TO YOU AND/OR BYSTANDERS.

Position the tractor on a hard level surface.

Install mounting brackets on tractor as shown in Installation Instructions included with your Mounting Kit. For ease of handling bracket, insert chain hook into bracket hole. Using hoist, raise and tilt bracket aligning mounting kit holes. Figure 5-1.

Tighten all bolts equally during installation so that outside surface of brackets are level and the center line measurement from right to left hand mounting brackets (Dimension "A") reads 32" plus or minus 1/4" for M146 or 37" plus or minus 1/4" for M246. Figure 5-1.

Figure 5-1

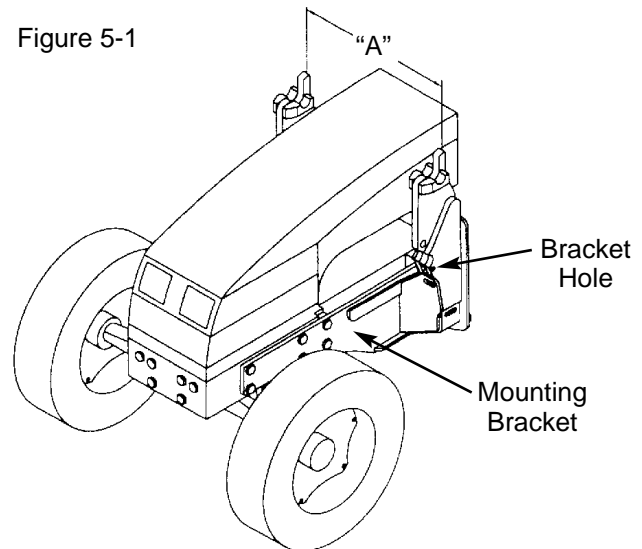

IMPORTANT

To prevent mounting kit hardware from loosening during operation, always torque mounting kit hardware to specified torque noted in Loader Operator's Manual.

IMPORTANT

If external valve is to be used, mount valve stand assembly, pages 27 - 30, to loader bracket before installing loader to the loader bracket. Bolts cannot be installed once loader is in place.

Remove all loader components from shipping packaging.

5-4 HYDRAULIC HOOKUP

For use with tractor hydraulic valve, install hoses to loader steel tubing. Install male quick couplers (cushomer furnished) to free ends of hoses.

For valve and stand mounting, refer to VALVE MOUNTING INSTRUCTIONS on pages 27 - 30.

Refer to individual instructions that come with the various other valve and control options.

IMPORTANT

When properly installed, the tractor remote valve or external valve control lever/levers will control the loader hydraulic circuits as described in Sections 3-4 - 3-8. Refer to tractor Operator's Manual for further explanation of tractor remote control lever/levers.

M146 LOADER VALVE MOUNTING INSTRUCTIONS FOR WALVOIL VALVE 50032442 SMALL VALVE & MOUNT KIT HYDRAULIC ATTACHMENT

VALVE PLUMBING ASSEMBLY

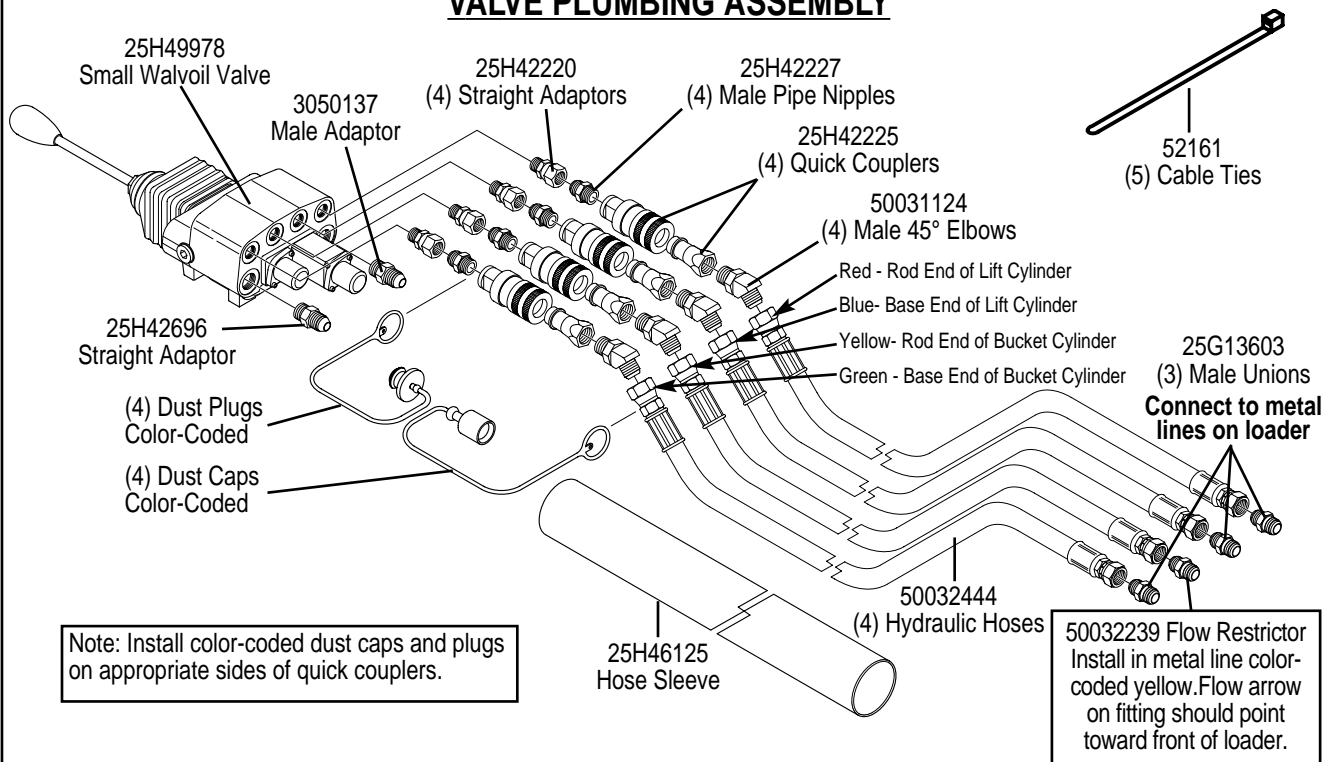

VALVE STAND ASSEMBLY

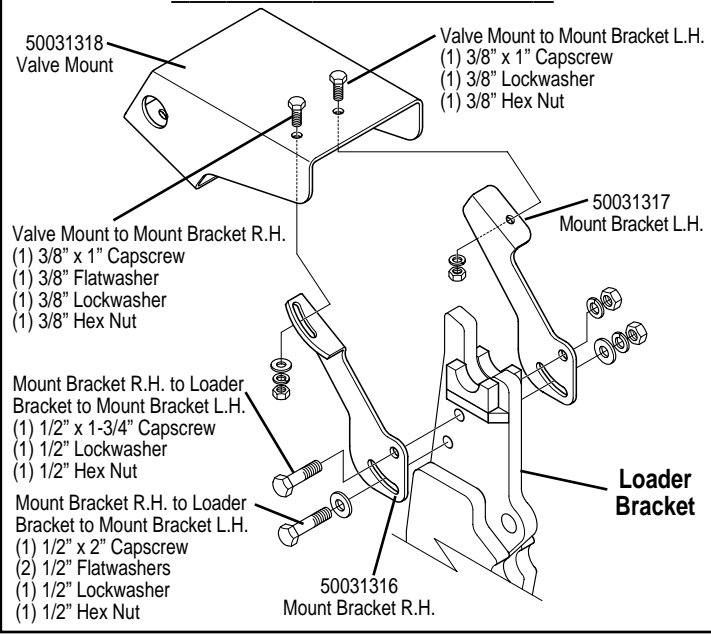

VALVE TO VALVE MOUNT ASSEMBLY

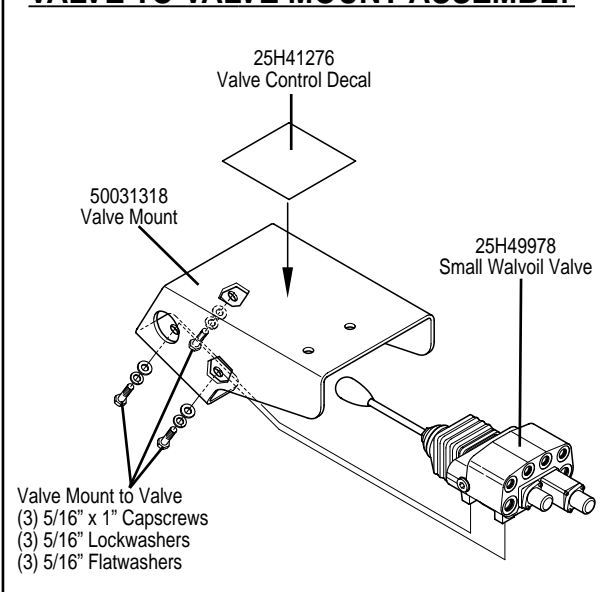

M146 LOADER VALVE MOUNTING INSTRUCTIONS FOR WALVOIL VALVE 50032443 SERIES VALVE & MOUNT KIT HYDRAULIC ATTACHMENT

VALVE PLUMBING ASSEMBLY

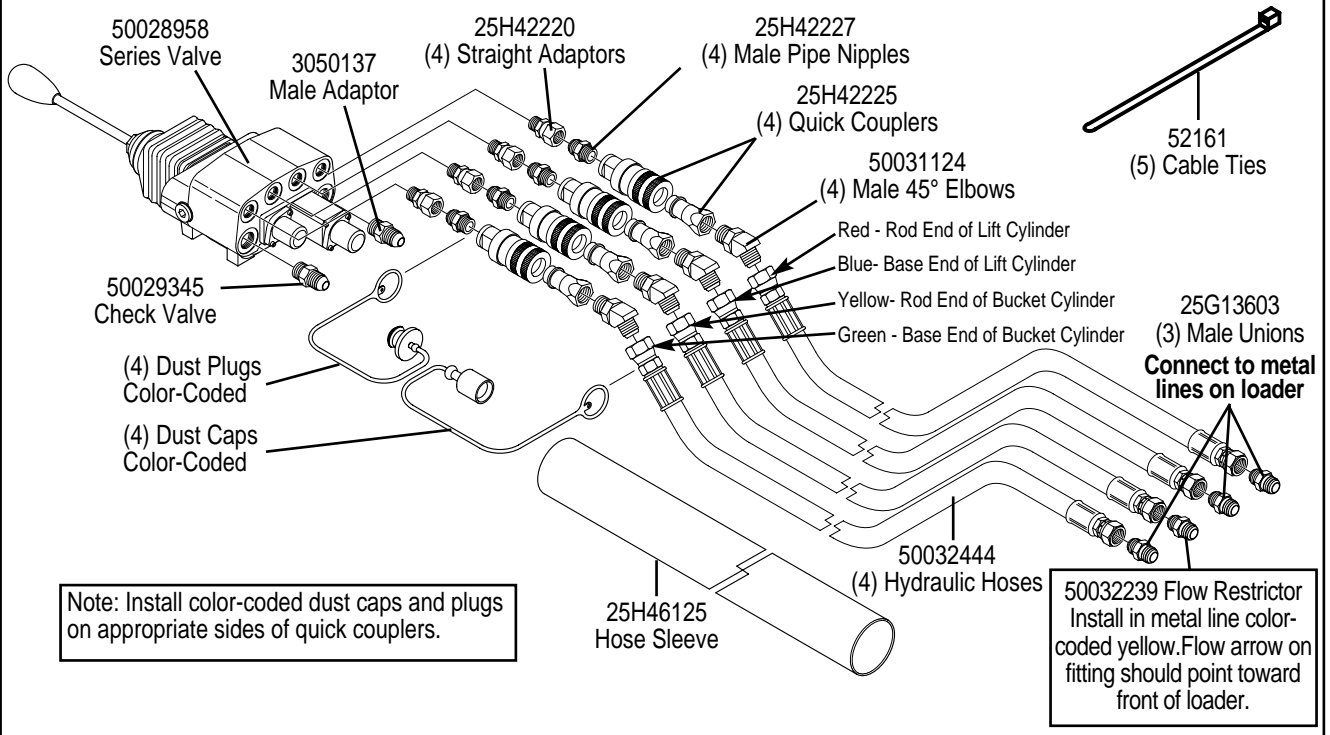

VALVE STAND ASSEMBLY

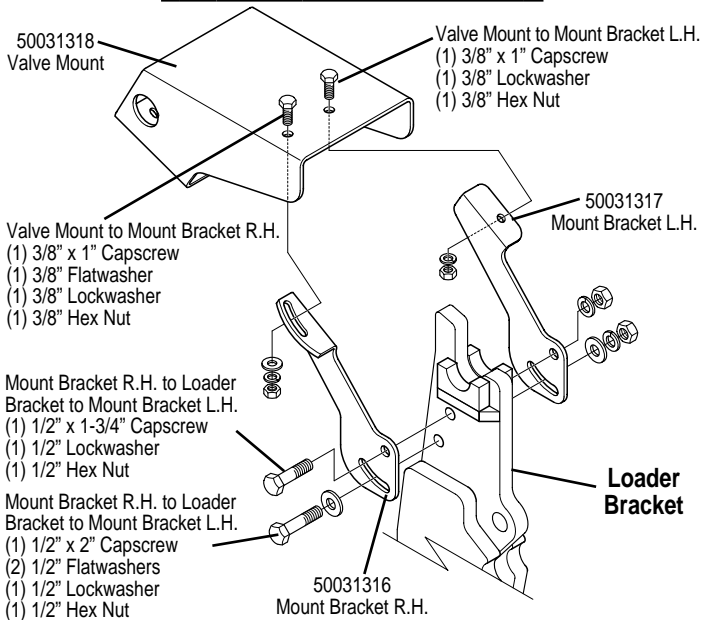

VALVE TO VALVE MOUNT ASSEMBLY

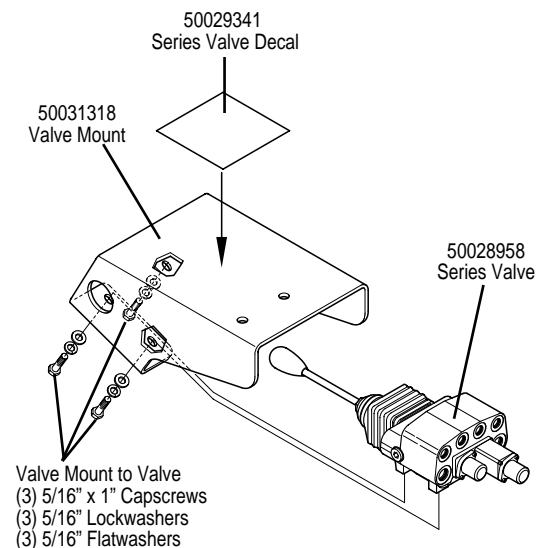

M246 LOADER VALVE MOUNTING INSTRUCTIONS FOR WALVOIL VALVE 50029340 SMALL VALVE & MOUNT KIT HYDRAULIC ATTACHMENT

VALVE PLUMBING ASSEMBLY

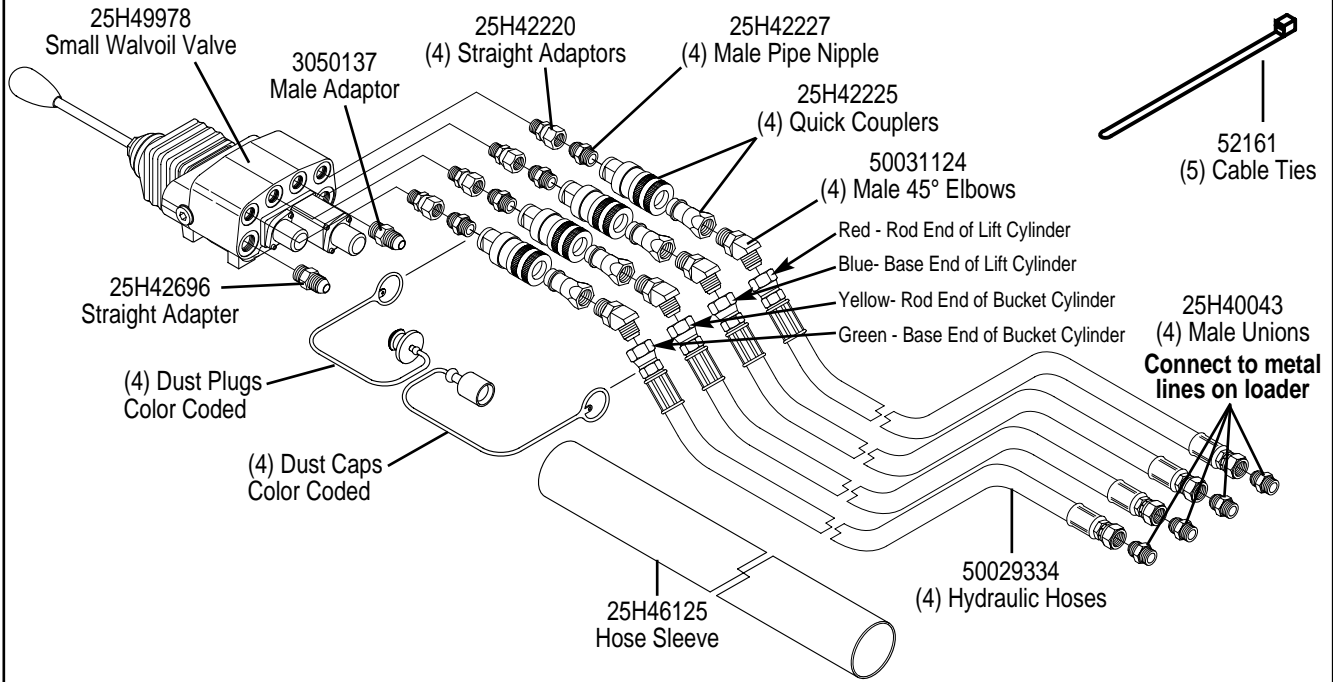

VALVE STAND ASSEMBLY

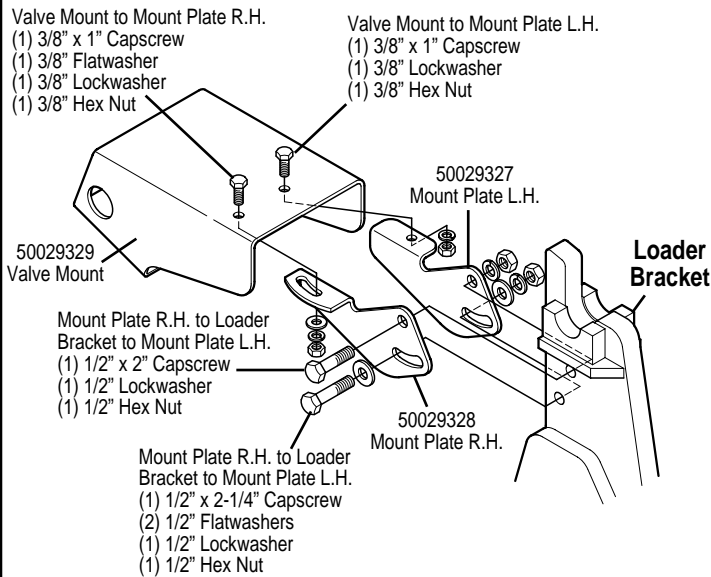

VALVE TO VALVE MOUNT ASSEMBLY

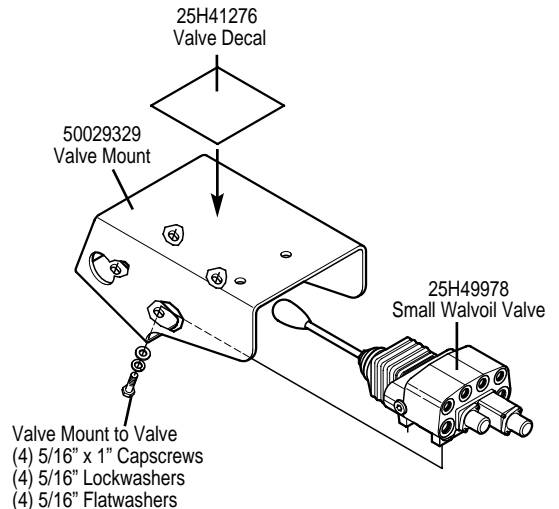

M246 LOADER VALVE MOUNTING INSTRUCTIONS FOR WALVOIL VALVE 50029330 SERIES VALVE & MOUNT KIT HYDRAULIC ATTACHMENT

VALVE PLUMBING ASSEMBLY

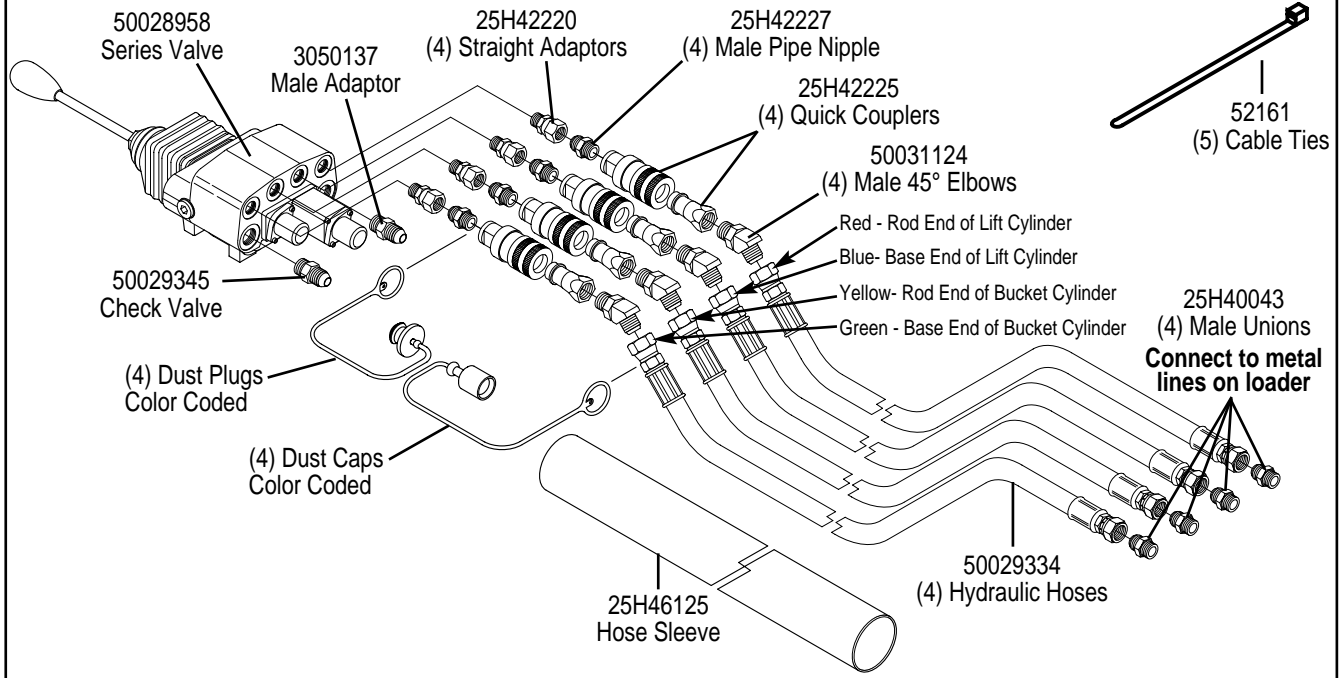

VALVE STAND ASSEMBLY

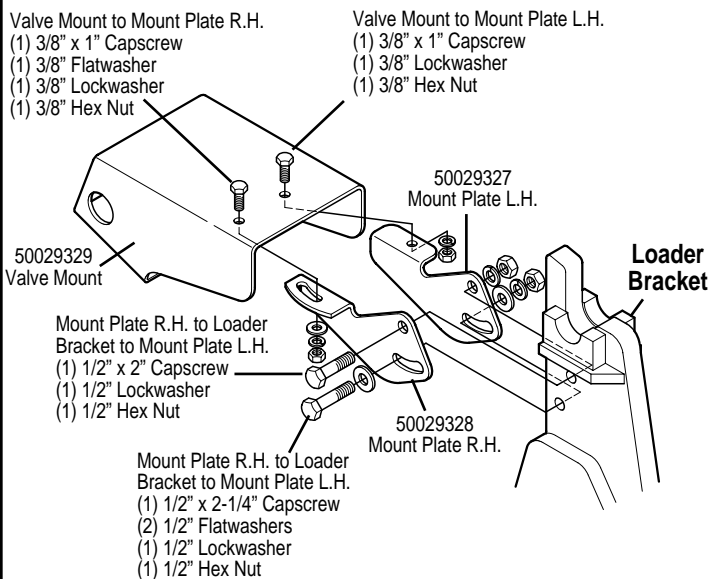

VALVE TO VALVE MOUNT ASSEMBLY

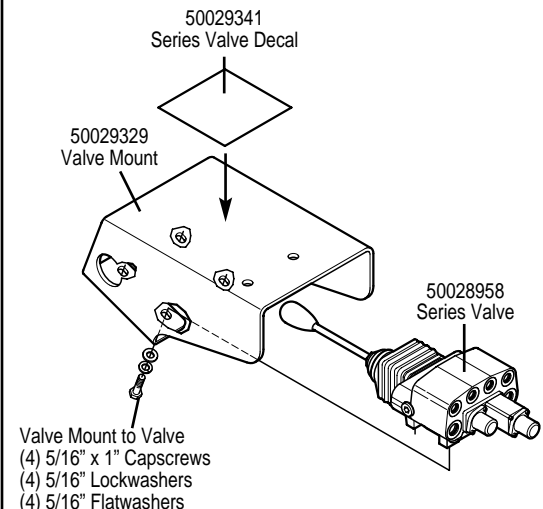

5-9 POWER BEYOND KIT

This Kit is provided to relieve excessive pressure on loader control valve when other implements are used while loader is still attached to tractor.

Kit Includes:

ITEM	QTY.	DESCRIPTION
1	1	Power Beyond Plug Assy.
2	1	Elbow 90° 9/16" ORB to 9/16" JIC
3	1	Hydraulic Hose 1/4" - 9/16" JIC Female
4	2	Straight Fitting 9/16" JIC male to 3/8" Pipe male
5	1	Quick Coupler Assy.

***NOTE:** Use the Power Beyond Plug Supplied with the Walvoil Valve. **DO NOT** use the plug supplied in the power beyond kit, it is only used with the Danfoss Valve.

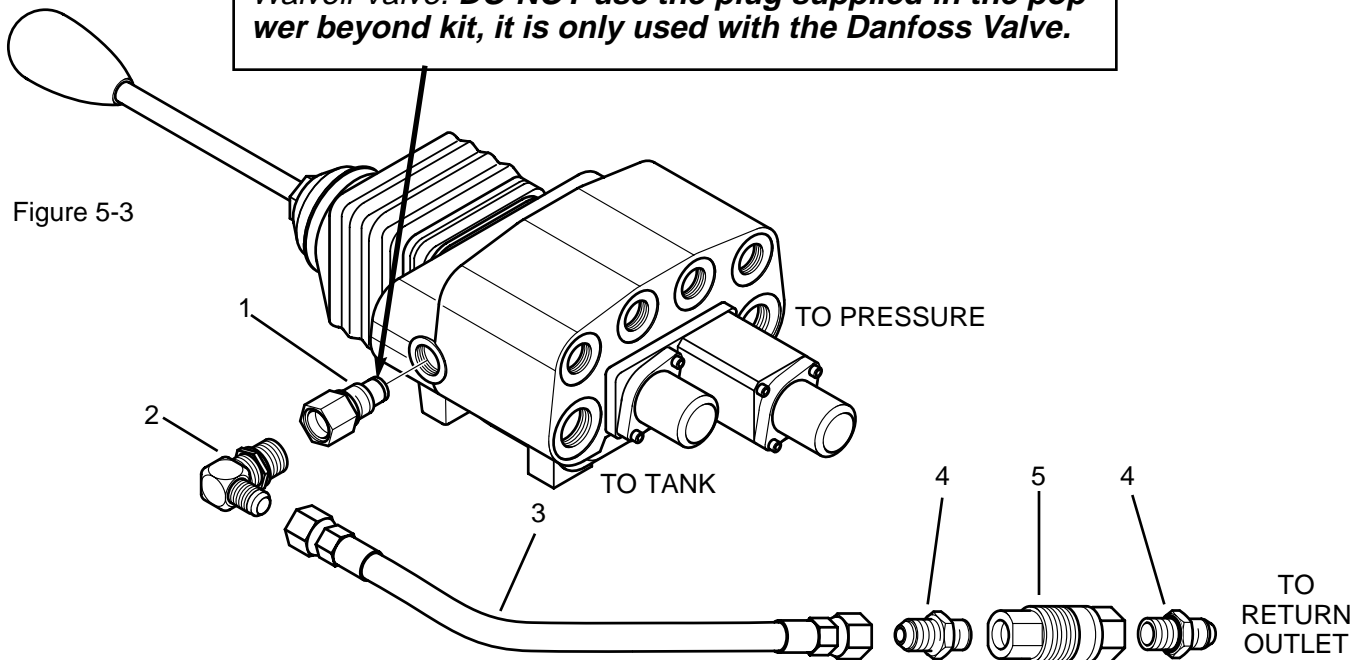

IMPORTANT: When Loader hydraulics are disconnected from tractor, the tractor hydraulic circuit must be completed by connecting pressure port to return port. Failure to do this will cause serious damage to tractor hydraulic pump.

INSTALLATION INSTRUCTIONS

1. Remove plug from right side of valve.
2. Install power beyond plug in valve.
3. Install 90° elbow in power beyond plug.
4. Attach hydraulic hose to 90° elbow and route hose to return outlet on tractor.

NOTE: Additional fittings are required to attach hose to return outlet on tractor.

5-10 MOUNTING BRACKET EYEBOLT

Install eyebolt to each mounting kit center bracket and secure with hardware. Figure 5-2.

Figure 5-2

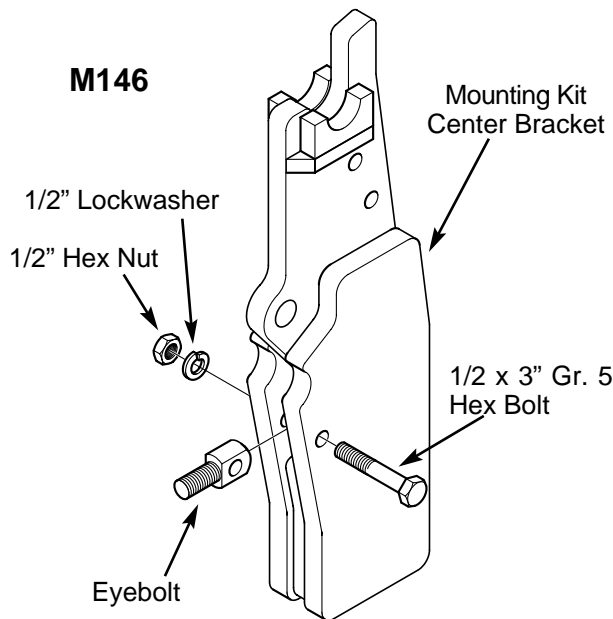
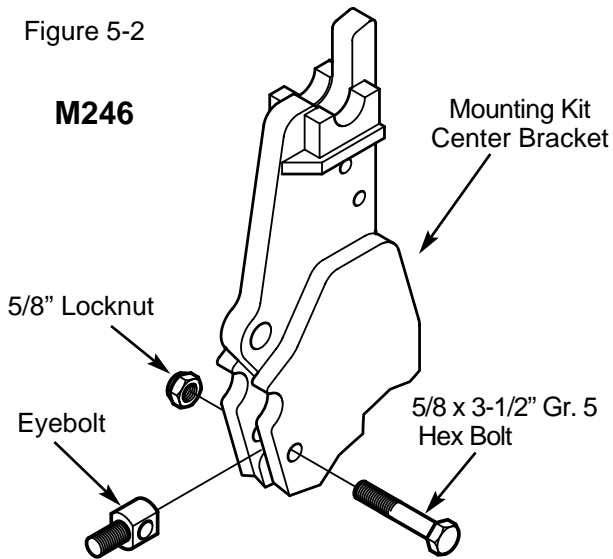

Verify that all mounting kit hardware has been torqued as specified before installing loader.

- Identify hardware size and grade.
- Refer to Torque Specifications, page 34, and find correct torque for your hardware size and grade.
- Torque hardware to this specification unless otherwise specified.

IMPORTANT

To prevent mounting kit hardware from loosening during loader operation always torque mounting kit hardware to specified torque.

Support the loader by using a hoist. Refer to Mounting The Loader, page 10, to install the loader to mounting brackets previously installed on tractor.



LIFT AND SUPPORT ALL LOADER COMPONENTS SAFELY.

5-11 STANDARD BUCKET & LEVEL INDICATOR ROD

- Attach boom and hydraulic cylinders to bucket using fasteners provided, as shown in Figure 5-3.
- Place indicator rod through guide tube and position as shown. (Level Indicator Rod and guide tube may be mounted on the inside or outside of boom, as desired.) Attach guide tube to mainframe using 1/4" bolt, flat washer and lock nut. Do not over-tighten 1/4" locknut as this will prevent guide tube from pivoting freely.
- Attach lower end of indicator rod to bucket bracket using cotter pins and flat washers.

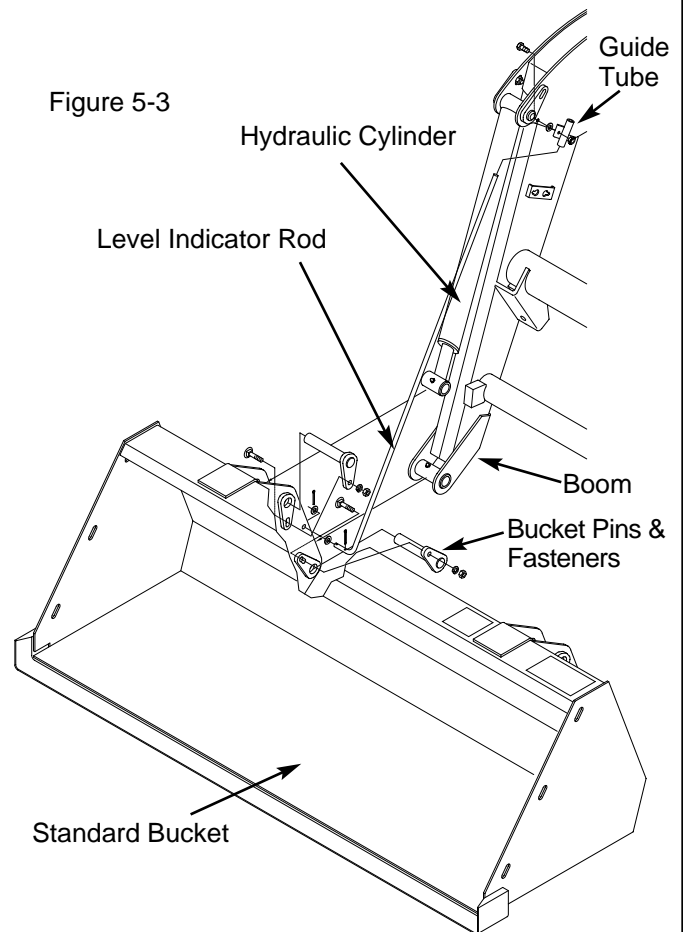

5-12 SKID STEER QUICK HITCH (M246 Only)

Attach the boom and hydraulic cylinders to the quick hitch assembly using the fasteners provided, as shown at right. The bucket level indicator rod is attached as explained in the previous section for the standard bucket.

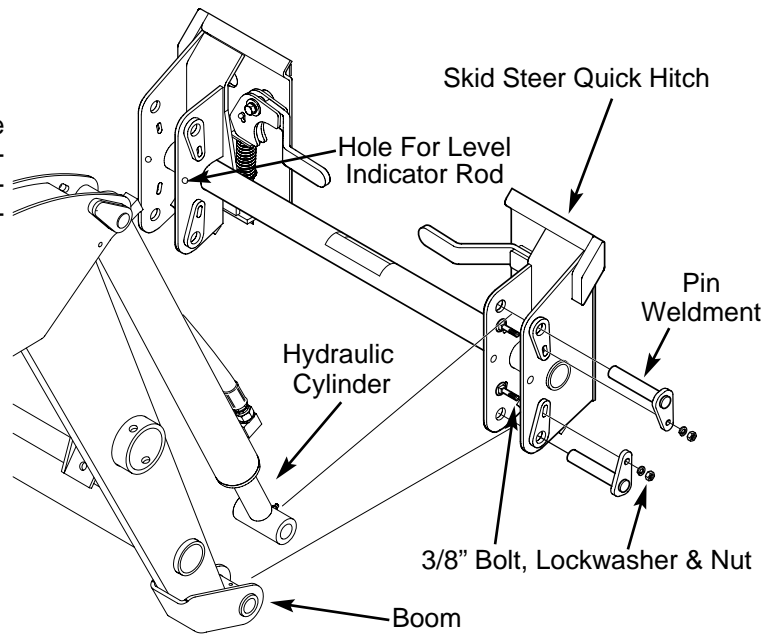

5-13 FORK LIFT OPTIONS (M246 Only)

Insert fork support rods through main frame and fork tubes. Secure in place with roll pins.

QUICK HITCH MODEL - For attaching to loader-mounted quick hitch assembly.

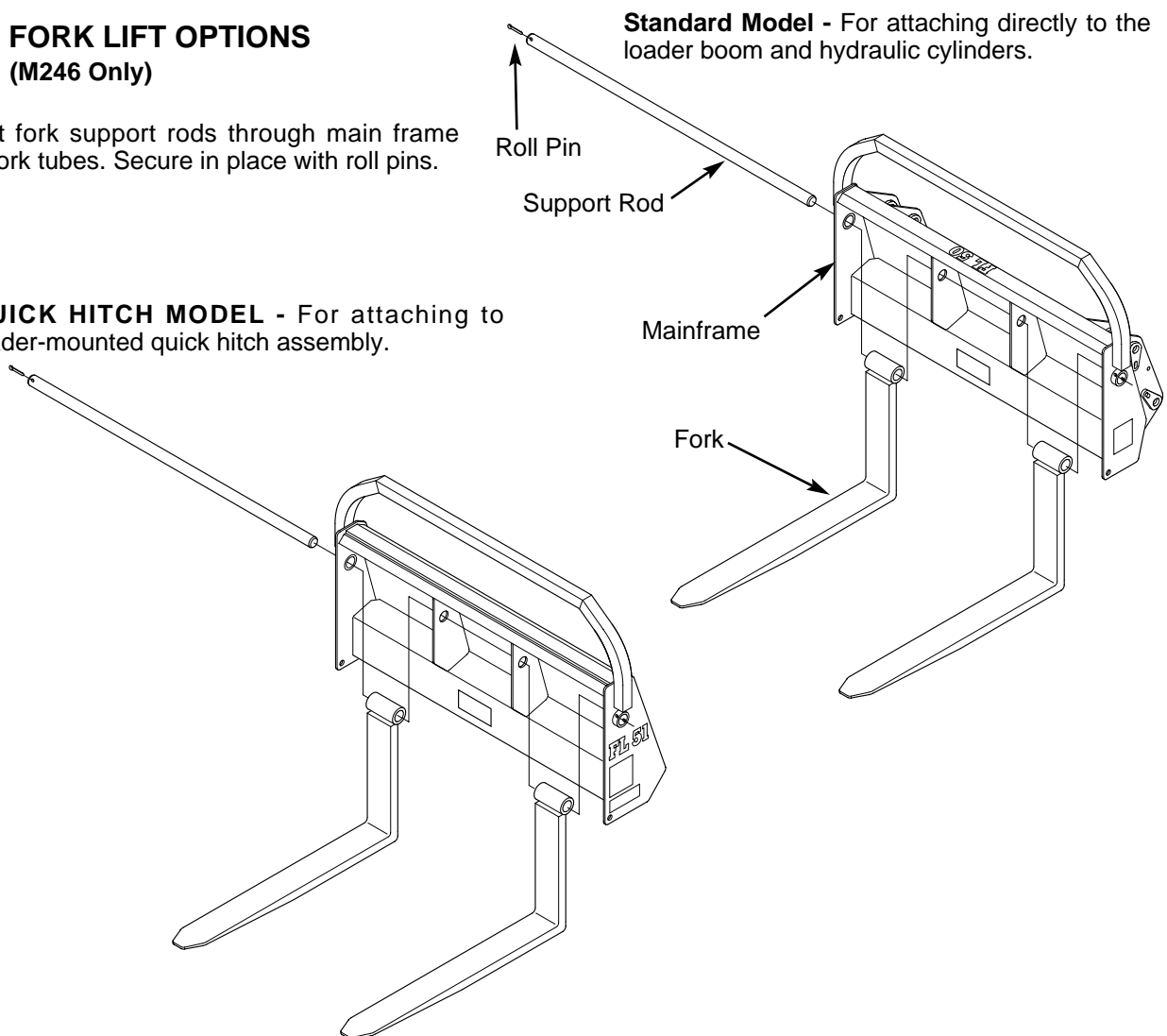

SAFETY DECALS

To promote safe operation, Bush Hog supplies safety decals on all products manufactured. Because damages can occur to safety decals either through shipment, use or reconditioning, Bush Hog will, upon request, provide safety decals for any of our products in the field at no charge. Contact your authorized Bush Hog dealer for more information.

Decals 50100231, 50100233, 50100234 and 24H41969 are located on the left side of the subframe and the mounting kit. Decal 50100238 is located on the lift and bucket cylinders and decal 50100243 is located on the hose shield. Other decals are located on attachments (Bucket, Fork Lift, etc.).



500100233

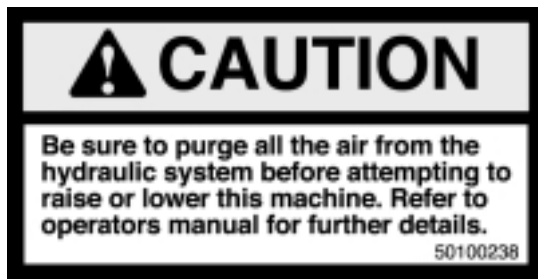

50100238

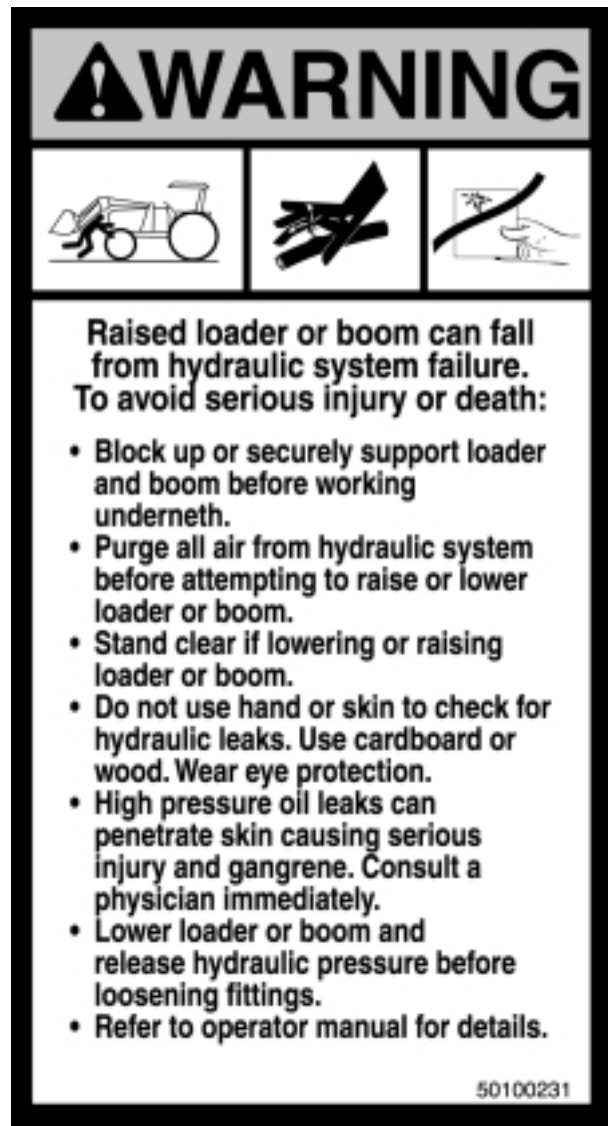

50100231



50100243

WARNING

TO AVOID SERIOUS INJURY OR DEATH:

Use sufficient tractor wheel ballast or rear weight and widest wheel settings for tractor stability during loader operation. See tractor owner's manual for specific recommendations or contact local dealer.

To avoid tractor overturn: Do not handle large heavy objects (large round bales, machinery, etc.) with loader. See owners manual for further information.

24H41969

24H41969

WARNING

Do not operate without confirmation that coupler pins are fully engaged. Loader attachment can fall off if not properly attached.

To avoid serious injury or death:

- Only use loader manufacturer approved attachments.
- Read all operators manuals and decals before operating. Follow all safety, operating, and service instructions. Contact dealer for replacement parts.

50100907

WARNING

THESE FORKS ARE NOT INTENDED FOR USE WITH LARGE OBJECTS SUCH AS ROUND HAY BALES OR OTHER ITEMS WHICH MAY ROLL BACKWARDS AND FALL, CAUSING INJURY TO THE OPERATOR.

Lift only objects that are within the stated lift capacity of the loader. Refer to your owner's manuals for the loader and for this fork attachment for load limits and other safety considerations.

62779

CAUTION

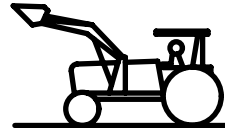

To avoid serious injury or death:

- Read operator manual and decals before operating. Follow all safety, operating, and service instructions. Contact dealer for replacement.
- Allow no children or unqualified persons to operate equipment.
- ROPS (Roll-Over Protective Structure) and seat belt equipped tractors are recommended for operator use in all loader operations.
- Add recommended wheel ballast or rear weight for stability.
- Move wheels to widest recommended settings to increase stability.
- Operate loader only from "Operator Seat".
- Lower attachment or loader boom to ground, stop engine, lock brakes, relieve hydraulic pressure, and remove key before leaving operators seat.
- Do not stand, work, or allow others under raised loader.
- Move and turn tractor at low speeds.
- Avoid tipping by careful operation near loose fill, rocks, holes, and when working on inclines.
- Carry loader arms at a low position during transport.
- Do not lift or carry anyone on buckets, forks, probes, or any other portion of the loader or loader attachments.
- Operator should wear safety hard hat, safety glasses, safety shoes, and other PPE. Avoid wearing loose clothing or jewelry that may catch in moving parts.

50100234

50100234

TORQUE SPECIFICATIONS

Proper torque for American fasteners used on Bush Hog equipment.
Recommended Torque in Foot Pounds (Newton Meters).*

AMERICAN Bolt Head Markings

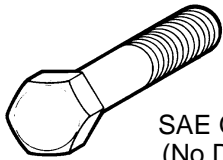

SAE Grade 2
(No Dashes)

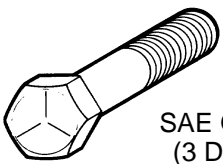

SAE Grade 5
(3 Dashes)

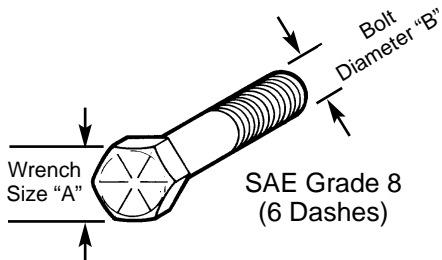

SAE Grade 8
(6 Dashes)

WRENCH SIZE (IN.) "A"	BOLT DIAMETER (IN.) "B" AND THREAD SIZE	SAE GRADE 2	SAE GRADE 5	SAE GRADE 8
7/16	1/4 - 20 UNC	6 (7)	8 (11)	12 (16)
7/16	1/4 - 28 UNF	6 (8)	10 (13)	14 (18)
1/2	5/16 - 18 UNC	11 (15)	17 (23)	25 (33)
1/2	5/16 - 24 UNF	13 (17)	19 (26)	27 (37)
9/16	3/8 - 16 UNC	20 (27)	31 (42)	44 (60)
9/16	3/8 - 24 UNF	23 (31)	35 (47)	49 (66)
5/8	7/16 - 14 UNC	32 (43)	49 (66)	70 (95)
5/8	7/16 - 20 UNF	36 (49)	55 (75)	78 (106)
3/4	1/2 - 13 UNC	49 (66)	76 (103)	106 (144)
3/4	1/2 - 20 UNF	55 (75)	85 (115)	120 (163)
7/8	9/16 - 12 UNC	70 (95)	109 (148)	153 (207)
7/8	9/16 - 18 UNF	79 (107)	122 (165)	172 (233)
15/16	5/8 - 11 UNC	97 (131)	150 (203)	212 (287)
15/16	5/8 - 18 UNF	110 (149)	170 (230)	240 (325)
1-1/8	3/4 - 10 UNC	144 (195)	266 (360)	376 (509)
1-1/8	3/4 - 16 UNF	192 (260)	297 (402)	420 (569)
1-5/16	7/8 - 9 UNC	166 (225)	430 (583)	606 (821)
1-5/16	7/8 - 14 UNF	184 (249)	474 (642)	668 (905)
1-1/2	1 - 8 UNC	250 (339)	644 (873)	909 (1232)
1-1/2	1 - 12 UNF	274 (371)	705 (955)	995 (1348)
1-1/2	1 - 14 UNF	280 (379)	721 (977)	1019 (1381)
1-11/16	1-1/8 - 7 UNC	354 (480)	795 (1077)	1288(1745)
1-11/16	1-1/8 - 12 UNF	397 (538)	890 (1206)	1444 (1957)
1-7/8	1-1/4 - 7 UNC	500 (678)	1120 (1518)	1817 (2462)
1-7/8	1-1/4 - 12 UNF	553 (749)	1241 (1682)	2013 (2728)
2-1/16	1-3/8 - 6 UNC	655 (887)	1470 (1992)	2382 (3228)
2-1/16	1-3/8 - 12 UNF	746 (1011)	1672 (2266)	2712 (3675)
2-1/4	1-1/2 - 6 UNC	870 (1179)	1950 (2642)	3161 (4283)
2-1/4	1-1/2 - 12 UNF	979 (1327)	2194 (2973)	3557 (4820)

METRIC

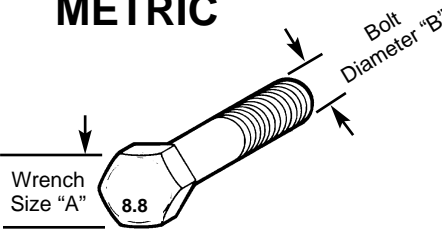

Numbers appearing on bolt heads indicate ASTM class.

Proper torque for metric fasteners used on Bush Hog equipment.
Recommended torque in foot pounds (newton Meters).*

WRENCH SIZE (mm) "A"	BOLT DIA. (mm) "B"	ASTM 4.6	ASTM 8.8	ASTM 9.8	ASTM 10.9
8	5	1.8 (2.4)		5.1 (6.9)	6.5 (8.8)
10	6	3 (4)		8.7 (12)	11.1 (15)
13	8	7.3 (10)		21.1 (29)	27 (37)
16	10	14.5 (20)		42 (57)	53 (72)
18	12	25 (34)	74 (100)	73 (99)	93 (126)
21	14	40 (54)	118 (160)	116 (157)	148 (201)
24	16	62 (84)	167 (226)	181 (245)	230 (312)
30	20	122 (165)	325 (440)		449 (608)
33	22		443 (600)		611 (828)
36	24	211 (286)	563 (763)		778 (1054)
41	27		821 (1112)		1138 (1542)
46	30	418 (566)	1119 (1516)		1547 (2096)

*Use 75% of the specified torque value for plated fasteners. Use 85% of the specified torque values for lubricated fasteners.



BUSH HOG[®], L.L.C.

**P.O. Box 1039 • Selma, AL 36702-1039
Telephone (334) 874-2700**

Free Manuals Download Website

<http://myh66.com>

<http://usermanuals.us>

<http://www.somanuals.com>

<http://www.4manuals.cc>

<http://www.manual-lib.com>

<http://www.404manual.com>

<http://www.luxmanual.com>

<http://aubethermostatmanual.com>

Golf course search by state

<http://golfingnear.com>

Email search by domain

<http://emailbydomain.com>

Auto manuals search

<http://auto.somanuals.com>

TV manuals search

<http://tv.somanuals.com>