

BUSH HOG®

Model 2347 QT Front End Loader Operator's Manual



OPERATION ● MAINTENANCE

1207

\$4.00

50057986

CONGRATULATIONS!

You have invested in the best implement of its type on the market today.

The care you give your Bush Hog implement will greatly determine your satisfaction with its performance and its service life. We urge a careful study of this manual to provide you with a thorough understanding of your new implement before operating, as well as suggestions for operation and maintenance.

If your manual should become lost or destroyed, Bush Hog will be glad to provide you with a new copy. Order from Bush Hog, P. O. Box 1039, Selma, Alabama 36702-1039. Most of our manuals can also be downloaded from our website at www.bushhog.com.

As an authorized Bush Hog dealer, we stock genuine Bush Hog parts which are manufactured with the same precision and skill as our original equipment. Our trained service personnel are well informed on methods required to service Bush Hog equipment, and are ready and able to help you.

Should you require additional information or assistance, please contact us.

YOUR AUTHORIZED
BUSH HOG DEALER

BECAUSE BUSH HOG MAINTAINS AN ONGOING PROGRAM OF PRODUCT IMPROVEMENT, WE RESERVE THE RIGHT TO MAKE IMPROVEMENTS IN DESIGN OR CHANGES IN SPECIFICATIONS WITHOUT INCURRING ANY OBLIGATION TO INSTALL THEM ON UNITS PREVIOUSLY SOLD.

BECAUSE OF THE POSSIBILITY THAT SOME PHOTOGRAPHS IN THIS MANUAL WERE TAKEN OF PROTOTYPE MODELS, PRODUCTION MODELS MAY VARY IN SOME DETAIL. IN ADDITION, SOME PHOTOGRAPHS MAY SHOW SHIELDS REMOVED FOR PURPOSES OF CLARITY. **NEVER OPERATE** THIS IMPLEMENT WITHOUT ALL SHIELDS IN PLACE.

2347 QT

TABLE OF CONTENTS

SECTION/PARA	PAGE	SECTION/PARA	PAGE
Warranty	2	3-5 Quick Hitch Operation.....	18
Dealer Preparation Check List.....	3	3-6 Transporting.....	18
Safety Precautions.....	4	IV MAINTENANCE	19
Federal Laws & Regulations.....	6	4-1 Maintenance Check List.....	19
I INTRODUCTION & DESCRIPTION	7	4-2 Lubrication.....	19
1-1 Introduction.....	7	4-3 Hydraulic System	
1-2 Description.....	7	Pressure Requirements.....	19
II LOADER MOUNTING & DISMOUNTING...9		4-4 Troubleshooting	20
2-1 Preparing Tractors.....	9	V ASSEMBLY	21
2-2 Mounting Loader.....	9	5-1 Mainframe Assembly.....	21
2-3 Dismounting Loader	11	5-2 Hydraulic Valve Stand Assembly	23
III OPERATING INSTRUCTIONS.....	12	5-3 Hydraulic Valve Plumbing	24
3-1 General Safety.....	12	5-4 Power Beyond Plumbing.....	25
3-2 Operation.....	12	5-5 Fork Lift Option.....	26
3-3 Bale Spear Operation	17	5-6 Bale Spear	26
3-4 Fork Lift Operation	18	Safety Decals	27
		Torque Specifications.....	28

RETAIL CUSTOMER'S RESPONSIBILITY UNDER THE BUSH HOG WARRANTY

It is the Retail Customer and/or Operator's responsibility to read the Operator's Manual, to operate, lubricate, maintain and store the product in accordance with all instructions and safety procedures. Failure of the operator to read the Operator's Manual is a misuse of this equipment.

It is the Retail Customer and/or Operator's responsibility to inspect the product and to have any part(s) repaired or replaced when continued operation would cause damage or excessive wear to other parts or cause a safety hazard.

It is the Retail Customer's responsibility to deliver the product to the authorized Bush Hog Dealer, from whom he purchased it, for service or replacement of defective parts which are covered by warranty. Repairs to be submitted for warranty consideration must be made within forty-five (45) days of failure.

It is the Retail Customer's responsibility for any cost incurred by the Dealer for traveling to or hauling of the product for the purpose of performing a warranty obligation or inspection.

UNDERSTAND SIGNAL WORDS

DANGER: Indicates an imminently hazardous situation which, if not avoided, will result in death or serious injury. This signal word is to be limited to the most extreme situations.

WARNING: Indicates a potentially hazardous situation which, if not avoided, could result in death or serious injury.

CAUTION: Indicates a potentially hazardous situation which, if not avoided, may result in minor or moderate injury. It may also be used to alert against unsafe practices.



LIMITED WARRANTY



Bush Hog warrants to the original purchaser of any new Bush Hog equipment, purchased from an authorized Bush Hog dealer, that the equipment be free from defects in material and workmanship for a period of one (1) year for non-commercial, state, and municipalities' use and ninety (90) days for commercial use from date of retail sale. The obligation of Bush Hog to the purchaser under this warranty is limited to the repair or replacement of defective parts.

Replacement or repair parts installed in the equipment covered by this limited warranty are warranted for ninety (90) days from the date of purchase of such part or to the expiration of the applicable new equipment warranty period, whichever occurs later. Warranted parts shall be provided at no cost to the user at an authorized Bush Hog dealer during regular working hours. Bush Hog reserves the right to inspect any equipment or parts which are claimed to have been defective in material or workmanship.

DISCLAIMER OF IMPLIED WARRANTIES & CONSEQUENTIAL DAMAGES

Bush Hog's obligation under this limited warranty, to the extent allowed by law, is in lieu of all warranties, implied or expressed, **INCLUDING IMPLIED WARRANTIES OF MERCHANTABILITY AND FITNESS FOR A PARTICULAR PURPOSE** and any liability for incidental and consequential damages with respect to the sale or use of the items warranted. Such incidental and consequential damages shall include but not be limited to: transportation charges other than normal freight charges; cost of installation other than cost approved by Bush Hog; duty; taxes; charges for normal service or adjustment; loss of crops or any other loss of income; rental of substitute equipment, expenses due to loss, damage, detention or delay in the delivery of equipment or parts resulting from acts beyond the control of Bush Hog.

THIS LIMITED WARRANTY SHALL NOT APPLY:

1. To vendor items which carry their own warranties, such as engines, tires, and tubes.
2. If the unit has been subjected to misapplication, abuse, misuse, negligence, fire or other accident.
3. If parts not made or supplied by Bush Hog have been used in connection with the unit, if, in the sole judgement of Bush Hog such use affects its performance, stability or reliability.
4. If the unit has been altered or repaired outside of an authorized Bush Hog dealership in a manner which, in the sole judgement of Bush Hog, affects its performance, stability or reliability.
5. To normal maintenance service and normal replacement items such as gearbox lubricant, hydraulic fluid, worn blades, or to normal deterioration of such things as belts and exterior finish due to use or exposure.
6. To expendable or wear items such as teeth, chains, sprockets, belts, springs and any other items that in the company's sole judgement is a wear item.

NO EMPLOYEE OR REPRESENTATIVE OF BUSH HOG IS AUTHORIZED TO CHANGE THIS LIMITED WARRANTY IN ANY WAY OR GRANT ANY OTHER WARRANTY UNLESS SUCH CHANGE IS MADE IN WRITING AND SIGNED BY BUSH HOG'S SERVICE MANAGER, POST OFFICE BOX 1039, SELMA, ALABAMA 36702-1039.



Record the model number, serial number and date purchased. This information will be helpful to your dealer if parts or service are required.

MODEL NUMBER _____

SERIAL NUMBER _____

MAKE CERTAIN THE WARRANTY REGISTRATION CARD HAS BEEN FILED WITH BUSH HOG/ SELMA, ALABAMA

DATE OF RETAIL SALE _____

DEALER PREPARATION CHECK LIST

2347 QT LOADER

BEFORE DELIVERING MACHINE - The following check list should be completed.
Use the Operator's Manual as a guide.

- Machine properly assembled.
- All safety decals readable. (See decal page)
- All bolts tightened to torque specifications given in torque chart.
- Machine operates properly.
- Customer has appropriate mounting kit for his tractor and loader.
- Customer has appropriate attachments for loader operations. (Buckets for lifting loose materials; bale spear for lifting round bales; fork lift for lifting palletized material)

 **CAUTION**

**IT IS RECOMMENDED THAT TRACTOR BE
EQUIPPED WITH ROLLOVER PROTECTIVE SYS-
TEM (ROPS) AND SEAT BELT BE USED FOR ALL
LOADER OPERATIONS.**

- Operators manual has been delivered to owner and he has been instructed on the safe and proper use of the front end loader.

Dealer's Signature _____

_____ THIS CHECK LIST TO REMAIN IN OPERATOR'S MANUAL _____

It is the responsibility of the dealer to complete the procedures listed
above before delivery of this implement to the customer.

IMPORTANT SAFETY PRECAUTIONS

This symbol is used to call attention to safety precautions that should be followed by the operator to avoid accidents. When you see this symbol, carefully read the message that follows and heed its advice. Failure to comply with safety precautions could result in serious bodily injury.



In addition to the design and configuration of equipment, hazard control and accident prevention are dependent upon the awareness, concern, prudence and proper training of personnel in the operation, transport, maintenance and storage of equipment. Lack of attention to safety can result in accident, personal injury, reduction of efficiency and worst of all—loss of life. Watch for safety hazards and correct deficiencies promptly. Use the following safety precautions as a general guide to safe operations when using this machine. Additional safety precautions are used throughout this manual for specific operating and maintenance procedures. Read this manual and review the safety precautions often until you know the limitations.

THE TRACTOR

1. Read the tractor operator's manual to learn how to operate your tractor safely. Failure to do so could result in serious injury or death and equipment damage.
2. It is recommended that tractor be equipped with Rollover Protective System (ROPS) and a seat belt be used for all loader operations.
3. Always remove or lockout tractor's hydraulic control valve detents when operating loader directly off of tractor auxiliary outlets. This allows control levers to return to neutral when manually released to stop loader movement.
4. Add wheel ballast or rear weight for stability.
5. Move wheels to the tractor manufacturer's widest recommended settings to increase stability.
6. For better stability, use tractor with wide front axle rather than tricycle front wheels.
7. Move and turn the tractor at low speeds.
8. Stop tractor engine, place transmission in park (or neutral), engage parking brake, lower loader arms to ground, cycle all hydraulic controls to relieve pressure, allow machine moving parts to stop, remove ignition key to prevent unauthorized person from starting engine before dismounting tractor or servicing, repairing, or making adjustments to the equipment.
9. Wear personal protective equipment (PPE), such as, but not limited to, protection for eyes, ears, lungs, head, hands and feet when operating, servicing, or repairing equipment. Avoid wearing loose clothing or jewelry that may catch and entangle on equipment moving parts.

THE LOADER

1. Read the loader operator's manual to learn how to operate your loader safely. Failure to do so could result in serious injury or death and equipment damage.
2. Become familiar with all the machine's controls and all the caution, warning and danger decals affixed to the machine before attempting to start or operate.
3. Improper use of a loader can cause serious injury or death.
4. Do not lift or carry anybody on the loader or in the bucket or attachment.
5. Never allow anyone to get under the loader bucket or reach through the booms when the bucket is raised.
6. Do not walk or work under a raised loader bucket or attachment unless it is securely blocked or held in position.
7. Avoid overhead wires and obstacles when loader is raised. Contacting electrical lines can cause electrocution.
8. Make sure all parked loaders on stands are on a hard, level surface.

SAFETY PRECAUTIONS CONTINUED

9. Use a piece of cardboard or wood rather than hands and wear eye protection when searching for hydraulic leaks. Escaping hydraulic oil under pressure can penetrate skin. If oil is injected into skin, it must be surgically removed within a few hours by a doctor or gangrene may result.
10. Before disconnecting hydraulic lines, relieve all hydraulic pressure.
11. Do not tamper with the relief valve setting. The relief valve is pre-set at the factory. Changing the setting can cause overloading the loader and tractor and serious operator injury may result.
12. Always wear safety goggles when repairing or servicing machine.
13. When servicing or replacing pins in cylinder ends, buckets, etc., always use a brass drift and hammer. Failure to do so could result in injury from flying fragments.
14. Replace damaged or illegible safety decals. See decal page for required decals.
15. Do not modify or alter or permit anyone else to modify or alter the loader, any of its components or any loader function without first consulting your local dealer.

OPERATING THE LOADER

1. It is the loader owner's responsibility to instruct and have a person read operator's manual, safety decals and become familiar with machine controls before allowing them to operate loader.
2. Do not allow children to operate the loader.
3. Before starting or operating the equipment, make a walk around inspection and check for loose or damaged components. Correct any deficiency before starting.
4. Keep the area of operation clear of all persons, particularly small children. The operator should cease operation whenever anyone comes within the operating area.
5. Operate the loader from the "Operator's Seat Only."
6. Exercise caution when operating the loader with a raised loaded bucket, fork, or large round hay bale handling attachments.
7. Avoid loose fill, rocks and holes. They can be dangerous for loader operation or movement.
8. Be extra careful when working on inclines.
9. Allow for the loader length when making turns.
10. Stop the loader arms gradually when lowering or lifting.
11. Use caution when handling loose or shiftable loads.
12. Carry loader arms at a low position during transport.
13. Lower loader arms, stop engine, and lock brakes before leaving the tractor seat.
14. Operate the loader controls only when properly seated at the controls.
15. Do not use loader for handling large, heavy objects such as logs, oil drums, etc.
16. Handling large, heavy objects is dangerous due to:
 - *Possibility of rolling the tractor over.
 - *Possibility of upending the tractor.
 - *Possibility of the object rolling or sliding down the loader arms onto the operator.
17. Use large round hay bale handler attachment with bale retaining devices (grapples, bale spears, clamps, etc.) to handle large round hay bales. Failure to use retaining devices could allow round hay bales to roll or fall down loader boom arms onto the operator causing serious injury or death and equipment damage.

IMPORTANT FEDERAL LAWS AND REGULATIONS* CONCERNING EMPLOYERS, EMPLOYEES AND OPERATIONS.

*(This section is intended to explain in broad terms the concept and effect of the following federal laws and regulations. It is not intended as a legal interpretation of the laws and should not be considered as such).

U.S. Public Law 91-596 (The Williams-Steiger Occupational and Health Act of 1970) OSHA

This Act Seeks:

"...to assure so far as possible every working man and woman in the nation safe and healthful working conditions and to preserve our human resources..."

DUTIES

Sec. 5 (a) Each employer—

- (1) shall furnish to each of his employees employment and a place of employment which are free from recognized hazards that are causing or are likely to cause death or serious physical harm to his employees;
- (2) shall comply with occupational safety and health standards promulgated under this Act.
 - (b) Each employee shall comply with occupational safety and health standards and all rules, regulations and orders issued pursuant to this Act which are applicable to his own actions and conduct.

OSHA Regulations

Current OSHA regulations state in part: "At the time of initial assignment and at least annually thereafter, the employer shall instruct every employee in the safe operation and servicing of all equipment with which the employee is, or will be involved." These will include (but are not limited to) instructions to:

Keep all guards in place when the machine is in operation;

Permit no riders on equipment;

Stop engine, disconnect the power source, and wait for all machine movement to stop before servicing, adjusting, cleaning or unclogging the equipment, except where the machine must be running to be properly serviced or maintained, in which case the employer shall instruct employees as to all steps and procedures which are necessary to safely service or maintain the equipment.

Make sure everyone is clear of machinery before starting the engine, engaging power, or operating the machine.

EMPLOYEE TRACTOR OPERATING INSTRUCTIONS:

1. Securely fasten your seat belt if the tractor has a ROPS.
2. Where possible, avoid operating the tractor near ditches, embankments, and holes.
3. Reduce speed when turning, crossing slopes, and on rough, slick, or muddy surfaces.
4. Stay off slopes too steep for safe operation.
5. Watch where you are going, especially at row ends, on roads, and around trees.
6. Do not permit others to ride.
7. Operate the tractor smoothly - no jerky turns, starts, or stops.
8. Hitch only to the drawbar and hitch points recommended by tractor manufacturers.
9. When tractor is stopped, set brakes securely and use park lock if available.

Child Labor Under 16 Years Old

Some regulations specify that no one under the age of 16 may operate power machinery. It is your responsibility to know what these regulations are in your own area or situation. (Refer to U.S. Dept. of Labor, Employment Standard Administration, Wage & Home Division, Child Labor Bulletin #102.)

SECTION I INTRODUCTION AND DESCRIPTION

Figure 1-1 2346 QT Major Components

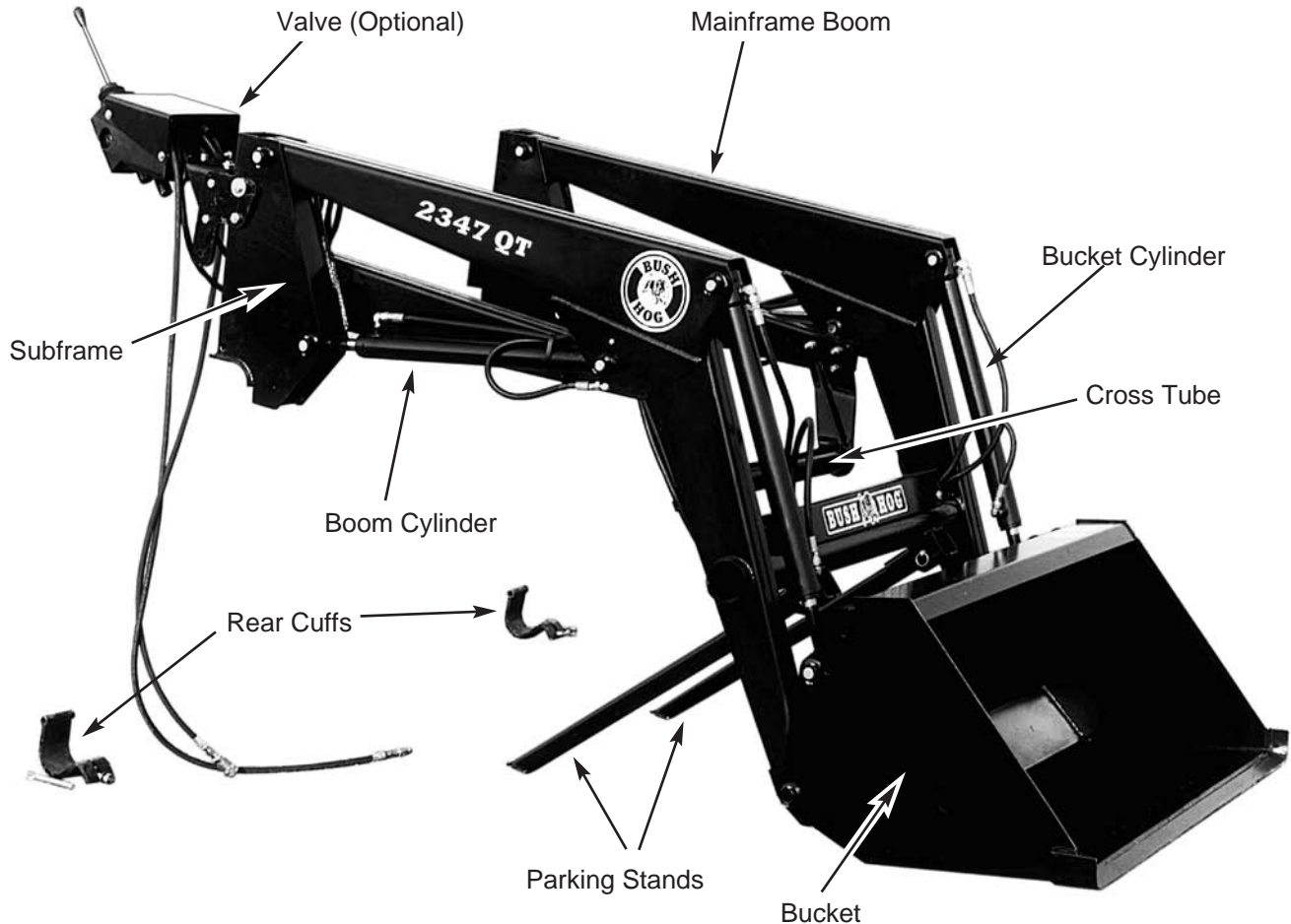

1-1 INTRODUCTION

We are pleased to have you as a Bush Hog customer. Your Front End Loader has been carefully designed to give maximum service with minimum down time. This manual is provided to give you the necessary operating and maintenance instructions for keeping your front end loader in top operating condition. Please read this manual thoroughly. Understand what each control is for and how to use it. Observe all safety precautions decaled on the machine and noted throughout the manual for safe operation of implement. If any assistance or additional information is needed, contact your authorized Bush Hog dealer.

NOTE

All references made to right, left, front, rear, top or bottom is as viewed facing the direction of forward travel with implement properly attached to tractor.

1-2 DESCRIPTION

The model 2347 QT Front End Loader (Figure 1-1) is designed for two wheel and four wheel drive tractors. It comes equipped with parking stands to support loader so tractor can be "driven in" for quick attachment and a bucket level indicator that allows operator to gauge bucket position when bucket cannot be seen. Available attachments include buckets for lifting loose materials; a bale spear for lifting round hay bales; and a fork lift for palletized material. All operations should be conducted within the loader limits specified in Table 1-1.

Table 1-1 TECHNICAL SPECIFICATIONS

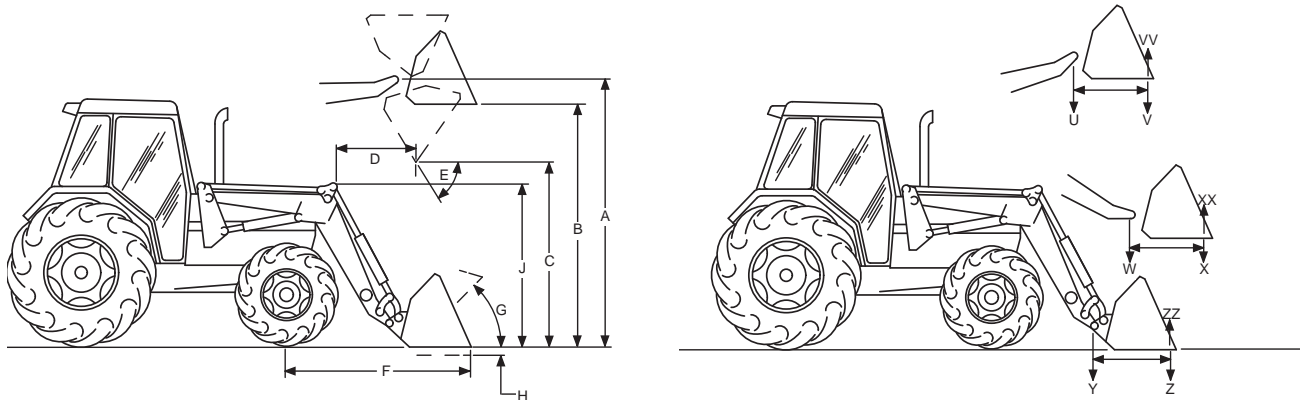

SERIES LOADER	2347QT
A. Maximum Lift Height - Measured at Pivot Pin	107 in.
B. Maximum Lift Height - Under Level Bucket	101 in.
C. Clearance with Attachment Dumped 45°	82 in.
D. Reach at Maximum Height	22 in.
E. Maximum Dump Angle	50°
F. Reach with Bucket on Ground	68 in.
G. Maximum Rollback Angle	22°
H. Digging Depth	3 in.
J. Overall Height in Carry Position	57 in.
U. Lift Capacity to Maximum Height - At Pivot Pin	1970 lbs.
V. Lift Capacity to Maximum Height - 31.5" Forward of Pivot Pin	1270 lbs.
W. Lift Capacity to 59" Height - At Pivot Pin	2200 lbs.
X. Lift Capacity to 59" Height - 31.5" Forward of Pivot Pin	1570 lbs.
Y. Breakout Force - At Pivot Pin	2985 lbs.
Z. Breakout Force - 31.5" Forward of Pivot Pin	2005 lbs.
VV. Rollback Force at Maximum Height - 31.5" Forward of Pivot Pin	2640 lbs.
XX. Rollback Force at 59" Height - 31.5" Forward of Pivot Pin	3220 lbs.
ZZ. Rollback Force at Ground Level - 31.5" Forward of Pivot Pin	2145 lbs.
Raising Time - Ground Level to Full Height	4 sec.
Lowering Time - Full Height to Ground	2 sec.
Bucket Dumping Time - Full Rollback to Full Dump	4 sec.
Bucket Rollback Time - Full Dump to Full Rollback	2 sec.
Tractor HP Range	25 - 50 2 & 4 WD
Specifications Based On Tractor System of	2450 psi hyd. pressure & 9 gpm pump cap.

SECTION II

LOADER MOUNTING AND DISMOUNTING

2-1 PREPARING TRACTOR

CAUTION

TRACTORS THAT HAVE MOVABLE AXLES MUST BE SET FORWARD IN THE LONG WHEELBASE POSITION AS SHOWN IN FIGURE 2-1 TO PREVENT EXCESSIVE LEVERAGE BEING EXERTED ON THE TRACTOR FRAME. FAILURE TO DO SO CAN RESULT IN PERSONAL INJURY AND EQUIPMENT DAMAGE. REFER TO TRACTOR OPERATOR'S MANUAL FOR ABOVE PROCEDURES AND SPECIFICATIONS FOR YOUR TRACTOR.

- A. Check air pressure in tractor tires to be sure it is adequate for heavy loads.
- B. Add rear wheel weights, fluid in tires, or equivalent to provide sufficient tractor stability.
- C. It is recommended that tractor wheels be moved to the widest settings.
- D. Check tractor hydraulic oil reservoir to be sure it is full.
- E. Refer to your tractor operator's manual for above procedures and specifications for your tractor.

2-2 MOUNTING LOADER

- A. Slowly drive tractor into loader. (Figure 2-2).

WARNING

**TO AVOID INJURY OR DEATH:
ALWAYS CONNECT LOADER HOSES TO APPROPRIATE TRACTOR AUXILIARY OUTLET. ALWAYS REMOVE OR LOCKOUT TRACTOR'S HYDRAULIC CONTROL VALVES DETENT POSITIONS FOR CONTROL LEVER NEUTRAL RETURN WHEN RELEASED TO STOP LOADER MOVEMENT.**

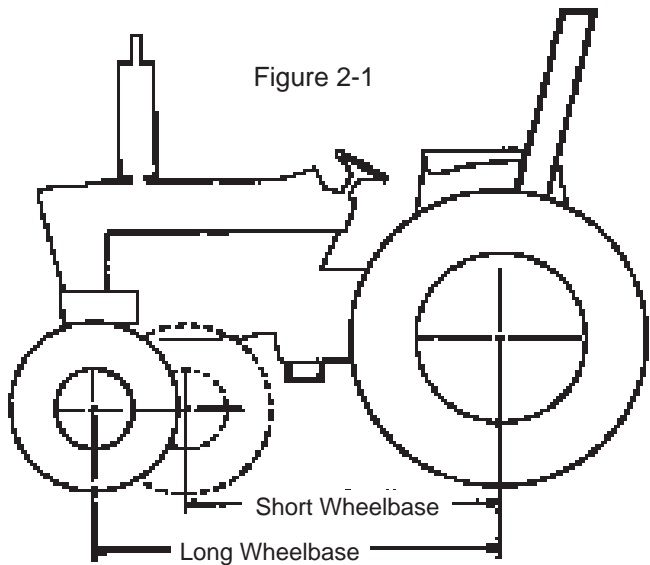

- B. Connect hydraulic hoses to appropriate tractor auxiliary outlets. **Note that proper connection of hoses will cause loader boom to raise and bucket to roll back when corresponding valve controls are pulled rearward. Also control having "float" position should allow boom to "float" when pushed forward to detent. (See decals in Figure 5-5)**

- C. Remove pin from front mounting bracket. Remove cuffs from loader subframe by loosening nut and removing pin. (Figure 2-2)

Figure 2-2 Drive In Close Enough To Allow Connecting Hydraulic Hoses To Tractor Outlets

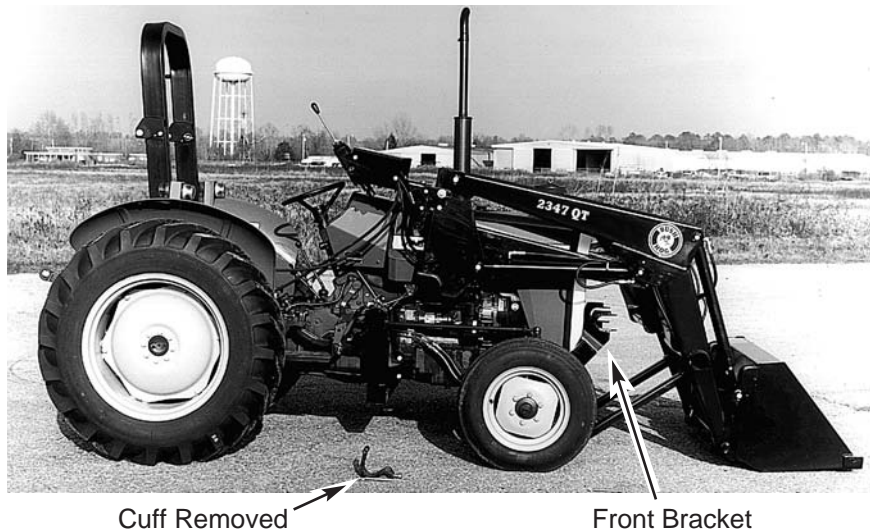

⚠ WARNING

USE CAUTION WHEN MOUNTING LOADERS EQUIPPED WITH OPTIONAL CONTROL VALVE ON TRACTORS EQUIPPED WITH CANOPY. RAISING LOADER SUBFRAME TOO HIGH CAN PINCH HAND BETWEEN CONTROL HANDLE AND CANOPY CAUSING INJURY.

D. With tractor at idle speed, carefully activate boom cylinders to raise/lower cross tube until it aligns with front bracket channel.

E. Drive tractor forward until cross tube fully engages front bracket channel and install front bracket pin. (Figure 2-3)

Figure 2-3 Front Bracket Pin



F. Extend bucket cylinder (dump) until subframe rest on rear bracket.

G. Install cuff as shown in Figure 2-4.

H. **Tighten nut retaining cuff to 85 ft./lbs.**

I. Raise boom, remove parking stands and slide into loader frame for storage. Retain parking stands with pins during storage. (Figure 2-5)

⚠ WARNING

DO NOT STAND UNDER LOADER WHILE REMOVING/INSTALLING PARKING STANDS.

J. Secure hydraulic hoses to tractor to prevent interference. It is recommended that hoses be routed under tractor operator's platform.

K. Extend and retract both sets of cylinders beginning with short strokes. Gradually increase the

Figure 2-4 Cuff Arrangement

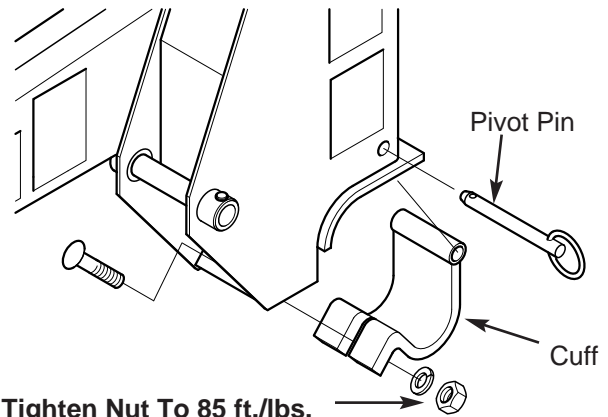

Tighten Nut To 85 ft./lbs.

Figure 2-5 Parking Stand Storage



Fully Insert Stands And Pin Into Place

length of stroke until cylinders "bottom out" in each direction. Hold valve open with cylinders "bottomed out" for 3-5 seconds. This will purge air from hydraulic components.

NOTE

When valve control is held open, a squealing noise will be heard when cylinders "bottom out" and hydraulic oil passes through relief valve. This may cause overheating if valve control is held open longer than 5 seconds.

Make certain optional control valve operates as shown on decal . If valve operation is incorrect, see plumbing diagrams for correct connections.

⚠ CAUTION

AIR IN HYDRAULIC COMPONENTS WILL CAUSE ERRATIC LOADER OPERATION. PURGE AIR FROM SYSTEM AS DESCRIBED ABOVE BEFORE WORKING WITH LOADER. FAILURE TO DO SO CAN RESULT IN PERSONAL INJURY AND EQUIPMENT DAMAGE.

Figure 2-6



2-3 DISMOUNTING LOADER

Dismount loader on firm, level ground to facilitate the next mounting. It is recommended that loader be stored in a dry place to prevent rusting.

A. Observe the position of boom cylinder mount-

ing bushing in relation to the subframe. (Figure 2-6) Remember this position to aid in aligning cross tube with front bracket when loader is being mounted to tractor.

B. Remove parking stands from storage. Raise boom and install as shown in Figure 2-7.

⚠ WARNING

DO NOT STAND UNDER LOADER WHILE REMOVING/INSTALLING PARKING STANDS.

Figure 2-7
Parking Stands Installed

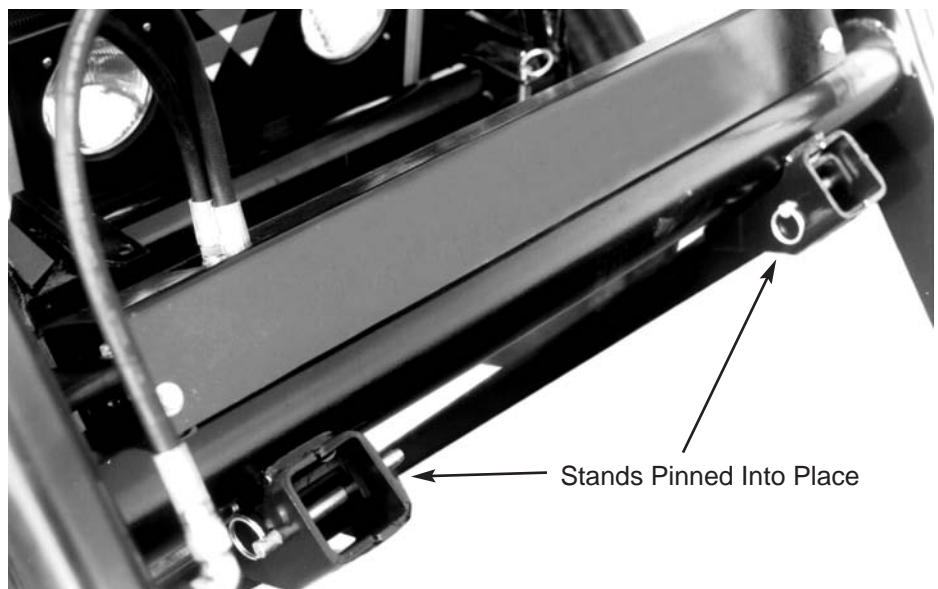

Figure 2-8
Loader Dismounted



C. Lower boom until parking stands contact ground.

D. Extend bucket cylinders until cutting edge of bucket is firmly on the ground.

E. Remove pin from mounting bracket.

F. Loosen nut securing cuffs to loader subframe. Remove pin securing cuff. Remove cuff.

G. With tractor at idle speed, roll bucket back until

subframe raises up off rear bracket.

H. With tractor at idle speed, carefully activate boom cylinder until cross tube is free of pressure within front bracket channel. It may be necessary to roll bucket back further to maintain sufficient clearance between subframe and rear cross tube.

I. Disconnect hydraulic hoses from tractor quick disconnect couplers.

J. Carefully back tractor out of loader. (Figure 2-8)

K. Reinstall cuffs to loader subframe and place pin in front mounting bracket for storage.

L. Clean all dirt and debris from loader. Dirt will hold moisture and cause rust.

M. If loader is to be stored for an extended period of time, perform lubrication per paragraph 4-2. Also apply coat of heavy grease to exposed cylinder rods to prevent rusting.

⚠ WARNING

USE CAUTION WHEN DISMOUNTING LOADERS EQUIPPED WITH OPTIONAL CONTROL VALVE ON TRACTORS EQUIPPED WITH CANOPY. RAISING LOADER SUBFRAME TOO HIGH CAN PINCH HAND BETWEEN CONTROL HANDLE AND CANOPY CAUSING INJURY.

SECTION III OPERATING INSTRUCTIONS

3-1 GENERAL SAFETY

Only qualified people familiar with this operator's manual should operate this machine. Operator should wear hard hat, safety glasses, and safety shoes. The operator should read, understand and practice all safety messages shown on the caution, warning and danger decals affixed to the loader to avoid serious injury or death. It is recommended that tractor be equipped with Rollover Protective System (ROPS) and a seat belt be used. Check for ditches, stumps, holes or other obstacles that could upset tractor or damage loader. Always turn off tractor engine, set parking brake, and lower loader to ground before leaving tractor operator's seat.

3-2 OPERATION

The loader should be operated with the tractor engine running at 1200-1700 rpm. **Excessive speeds are dangerous and may cause bucket spillage and unnecessary strain on both the tractor and loader.**

When operating in temperatures below 30°F (-1°C.), run the tractor engine below 1200 rpm until the oil temperature exceeds 30°F.

A bucket level, indicator rod (Figure 3-1) located on the loader frame can be used to determine bucket angle. Before beginning work, observe the position of indicator rod with bucket flat on ground. Raise boom to several different positions. At each position level bucket, then observe the indicator rod. Once familiar with the indicator rod positions, operation of loader will be easier and more efficient.

The following text and illustrations offer suggested loader and tractor operating techniques.

Figure 3-1

Level
Indicator Rod



FILLING THE BUCKET

Approach and enter the pile with a level bucket.

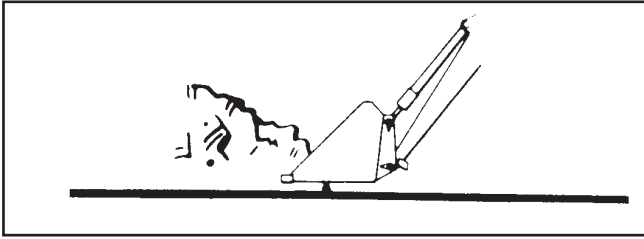

Loaders with 1-lever control, ease lever back and toward you to lift and rollback the bucket.

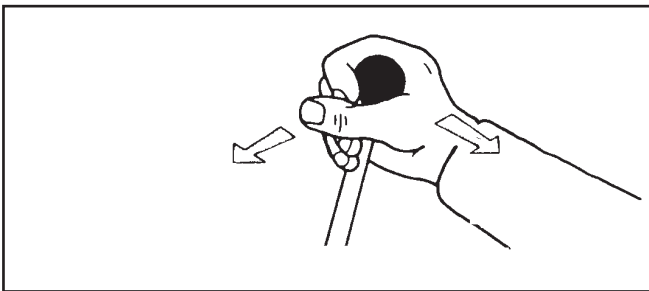

Loaders with 2-lever controls, ease both levers back to lift and rollback the bucket.

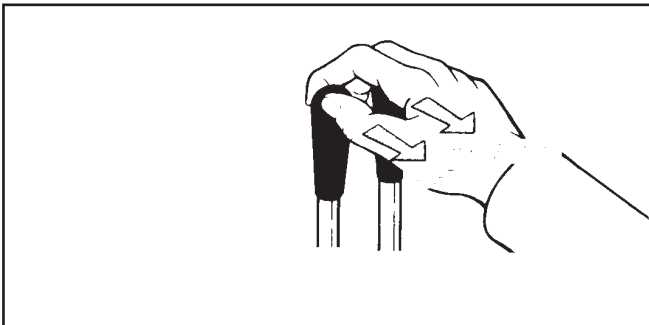

The lift and rollback of the bucket will increase efficiency because...

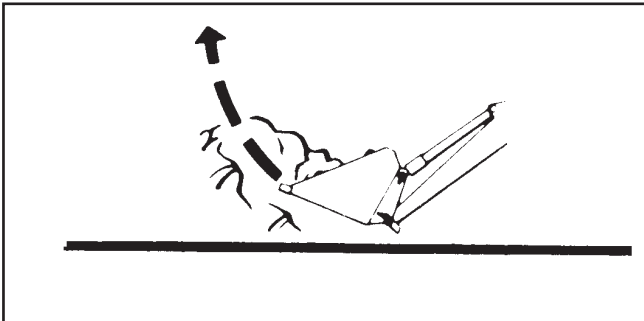

...a level bucket throughout the lifting cycle resists bucket lift and increases breakaway effort.

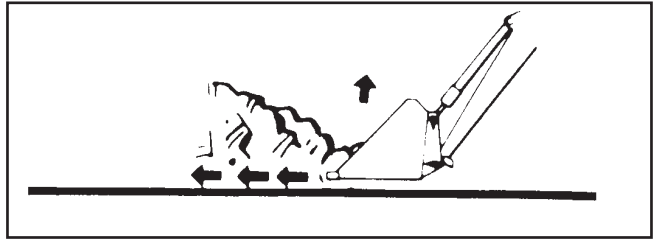

NOTE; Do not be concerned if the bucket is not completely filled during each pass. Maximum productivity is determined by the amount of material loaded in a given period of time. Time is lost if two or more attempts are made to fill the bucket on each pass.

LIFTING THE LOAD

WARNING

DO NOT LIFT OR CARRY ANYONE IN THE BUCKET OR ON ANY OTHER PORTION OF THE LOADER OR LOADER ATTACHMENT. INADVERTENT MOVEMENT OF THE LOADER OR ATTACHMENT COULD RESULT IN SERIOUS INJURY OR DEATH FROM FALLING OR CRUSHING.

CAUTION

MAKE SURE MATERIAL IN BUCKET CANNOT ROLL OUT AND DOWN ON TRACTOR WHEN BUCKET IS RAISED TO FULL HEIGHT. KEEP CLEAR OF OVERHEAD OBSTRUCTIONS SUCH AS TREES, LIMBS OR POWER LINES WHEN RAISING THE BUCKET

When lifting the load, keep the bucket positioned to avoid spillage.

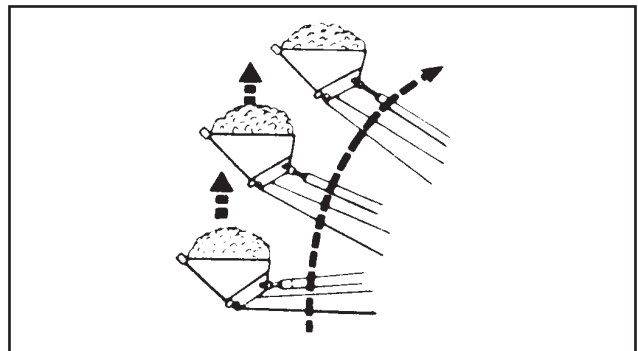

CAUTION

DO NOT ATTEMPT TO LIFT BUCKET LOADS IN EXCESS OF CAPACITIES LISTED IN TABLE 1-1 TECHNICAL SPECIFICATIONS.

CARRYING THE LOAD

Position the bucket as low as possible below the level of the tractor hood for maximum stability and visibility, whether the bucket is loaded or empty.

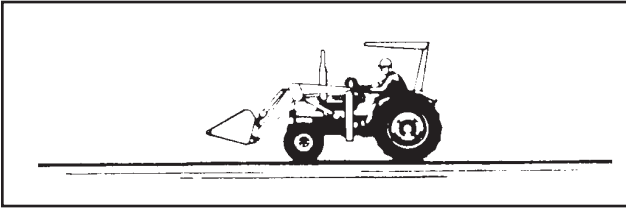

Use extreme caution when operating the loader on a slope and keep the bucket as low as possible. This keeps the bucket and tractor center of gravity low and will provide maximum tractor stability.

CAUTION

OPERATING THE LOADER ON A HILLSIDE IS DANGEROUS. EXTREME CARE IS RECOMMENDED.

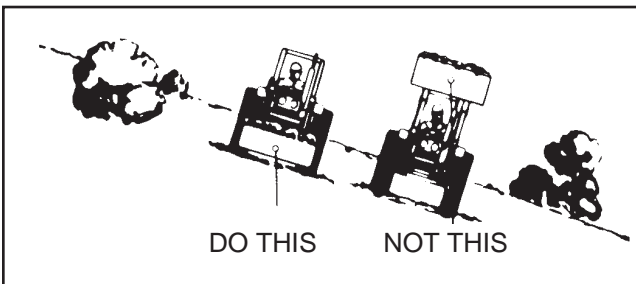

When transporting the load, keep the bucket as low as possible to avoid tipping, in case a wheel drops in a rut.

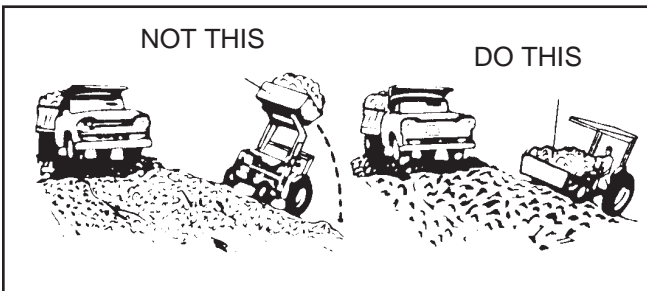

DUMPING THE BUCKET

Lift the bucket high enough to clear the side of the vehicle. Move the tractor in as close to the side of the vehicle as possible, then dump the bucket.

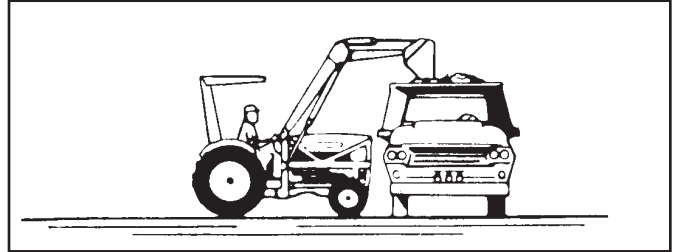

LOWERING THE BUCKET

After the bucket is dumped, back away from the vehicle while lowering and rolling back the bucket.

FLOAT POSITION

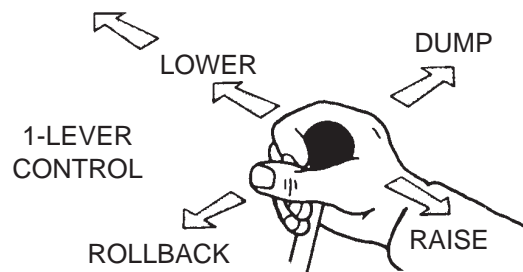

FLOAT POSITION

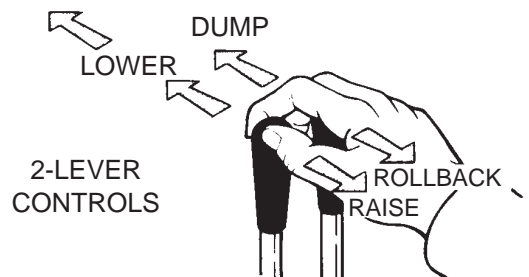

OPERATING WITH FLOAT CONTROL

During hard surface operation, keep the bucket level and put the lift control in the float position to permit the bucket to float on the working surface. If hydraulic down pressure is exerted on the bucket, it will wear faster than normal.

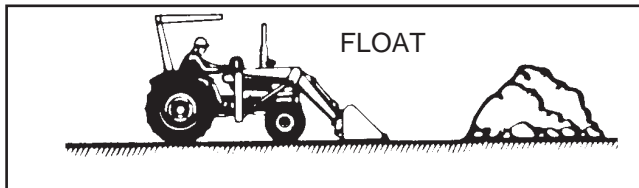

The float will also prevent the mixing of surface material with stockpile material. The float position will reduce the chance of surface gouging when removing snow or other material.

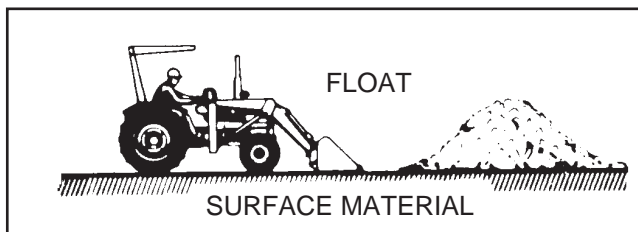

LOADING FROM A BANK

Choose a forward gear that provides sufficient ground speed for loading

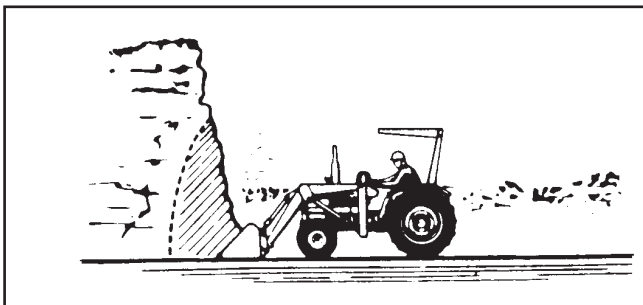

Exercise caution when undercutting high banks. Dirt slides can be dangerous. Load from as low as possible for maximum efficiency. Loader lift and break-away capacity diminish as loading height is increased.

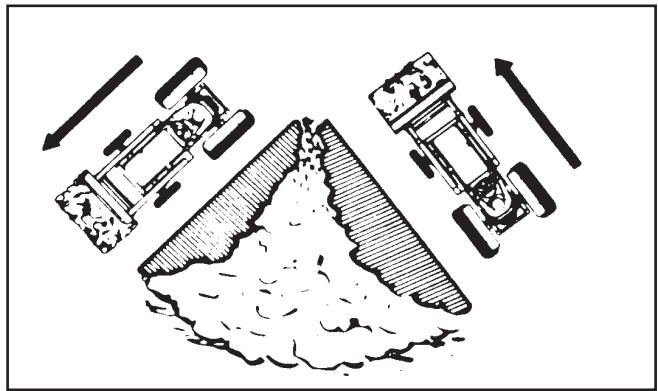

Sidecutting is a good technique for cutting down a big pile.

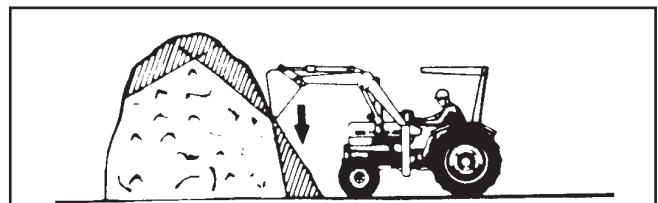

If the piles are too high and liable to cause cave-in, use the loader to break down the sides until a slot can be cut over the top.

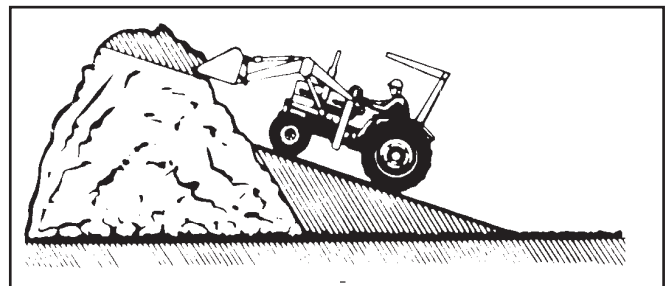

Another method for large dirt piles is to build a ramp approach to the pile.

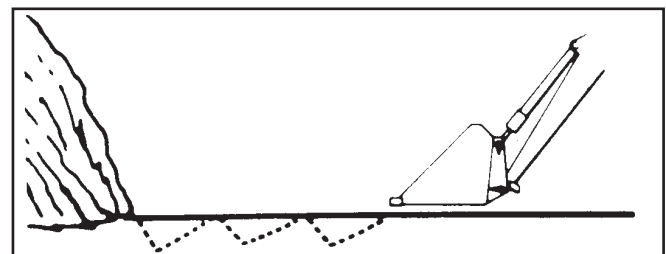

It's important to keep the bucket level when approaching a bank or pile. This will help prevent gouging the work area.

PEELING AND SCRAPING

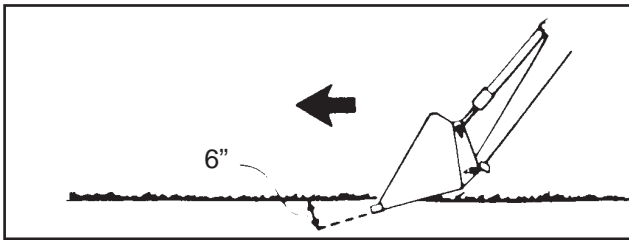

Use a slight bucket angle, travel forward, and hold the lift control forward to start the cut. Make a short, angle cut approximately 6" deep and break-out cleanly.

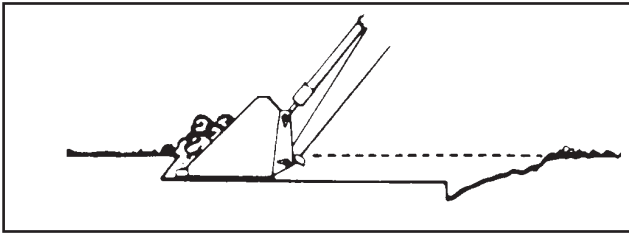

With the bucket level, start a cut at the notch approximately 2" deep. Hold the depth by feathering the bucket control to adjust the cutting lip up or down. When the front tires enter the notch, adjust the lift cylinder to maintain proper depth.

3RD CUT , 4TH CUT , ETC.

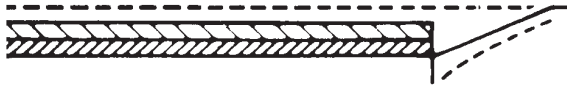

Make additional passes until the desired depth is reached. During each pass, only use the bucket control while at working depth. This will allow you to concentrate on controlling the bucket angle to maintain a precise cut.

LOADING LOW TRUCKS OR SPREADERS FROM A PILE

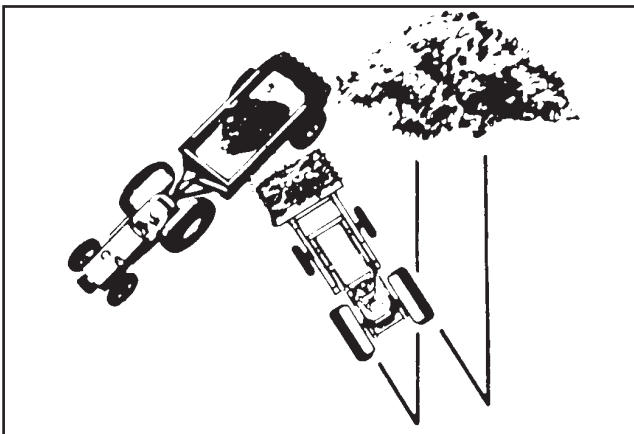

For faster loading, minimize the angle of turn and length of run between pile and spreader.

BACKFILLING

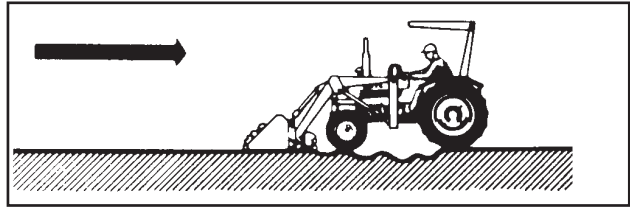

Backgrade occasionally with a loaded bucket to keep the working surface free of ruts and holes. Hold the lift control forward in **float position so the full weight** of the bucket is scraping the ground. Use only the heel of the bucket while backgrading.

IMPORTANT: To prevent damage to cylinders:

- (1) Do not backgrade with bucket cylinders extended.
- (2) Always backgrade with valve in **float position**.

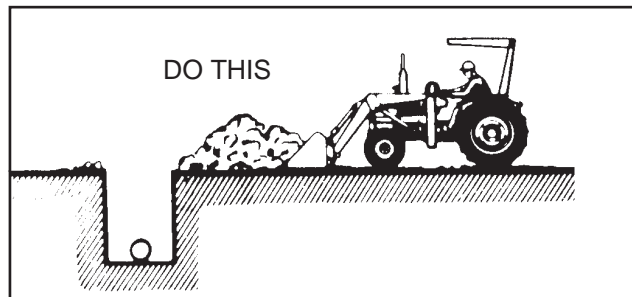

Approach the pile with a flat bucket.

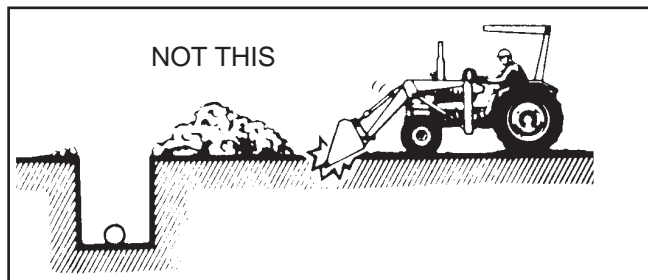

Poor methods actually move no more dirt and make it more difficult to hold a level grade.

Do not use the bucket in the dumped position for bulldozing or backgrading. This method, shown above, will impose severe shock loadings on the dump linkage, the bucket cylinder, and the tractor.

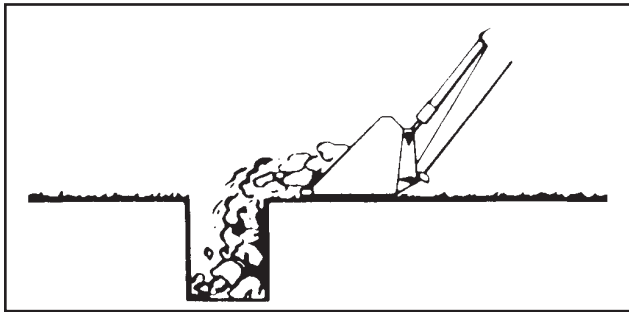

Leave dirt in the bucket because dumping on each pass wastes time.

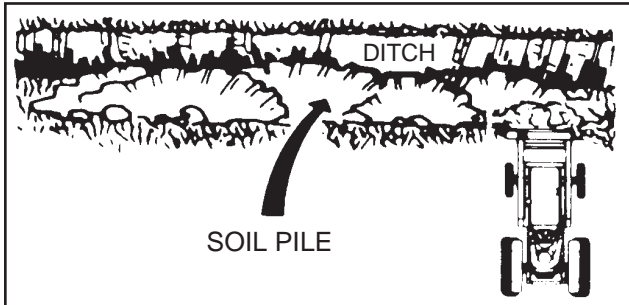

Operate at right angles to the ditch. Take as big a bite as the tractor can handle without lugging down.

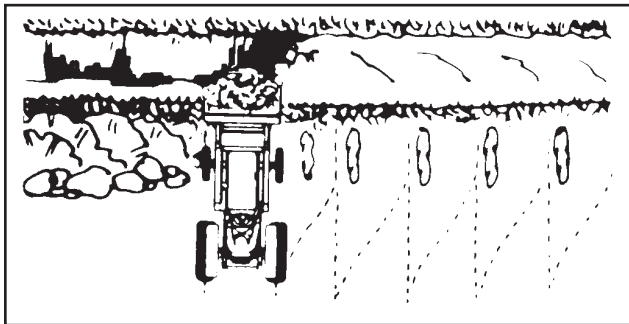

Leave dirt which drifts over the side of the bucket for final clean-up.

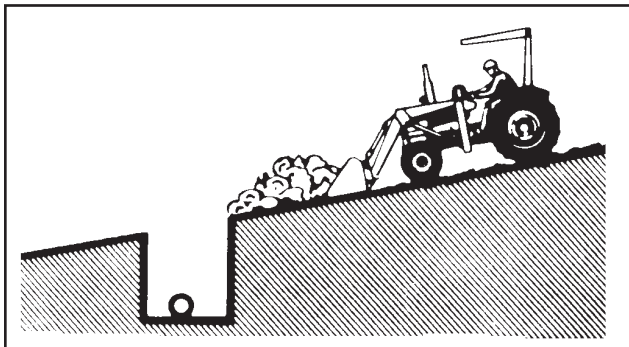

Pile dirt on the high side for easier backfilling on a slope.

HANDLING LARGE HEAVY OBJECTS

⚠ WARNING

Do not use front end loaders for handling large heavy objects such as logs or oil drums. Handle large round hay bales only when loader is equipped with Bush Hog Bale Spear Attachment.

Handling large heavy objects can be extremely dangerous due to:

- ★ Possibility of rolling the tractor over.
- ★ Possibility of upending the tractor.
- ★ Possibility of the object rolling or sliding down the loader arms onto the operator.

3-3 BALE SPEAR OPERATION

The bale spear (Figure 3-2) is intended for handling large round bales. Before operation, set tractor wheels to tractor manufacturer's widest recommended settings and add ballast as necessary to provide adequate stability for handling round bales. It is recommended that tractor be equipped with a ROPS and seat belts. Approach bale from downhill side with tractor in low gear. **Run spears all the way into bale with long spear as close to center as possible. Lift bale just high enough for adequate ground clearance to transport, maintaining good visibility. Always carry load as low as possible when transporting, for improved stability.** Use low gear on downhill grades. Unload round bales on a level surface.

Figure 3-2 Bale Spear

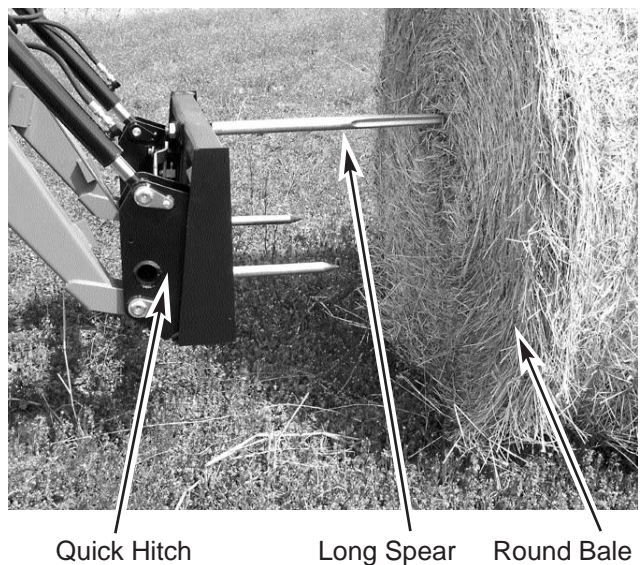

3-4 FORK LIFT OPERATION

⚠ WARNING

TO AVOID SERIOUS INJURY OR DEATH:

- ★ NEVER LIFT LARGE ROUND HAY BALES OR OTHER LOADS ON THE FORK LIFT ATTACHMENT THAT COULD ROLL BACK ONTO TRACTOR OPERATOR AREA.
- ★ NEVER USE FORK LIFT ATTACHMENT TO LIFT OR SUPPORT PEOPLE.
- ★ TRANSPORT LOADS LOW AND SLOW.
- ★ AVOID CONTACT WITH POWER LINES.

The fork lift attachment (Figure 3-3) is intended for handling palletized material. It is recommended that tractor be equipped with ROPS and seat belts. Use the loader dump cylinders to give the forks the desired tilt. Position the forks on their support rods to the desired width so that the load will be carried approximately equal on each fork. Position load as far back as possible.

Figure 3-3
Fork Lift Attachment

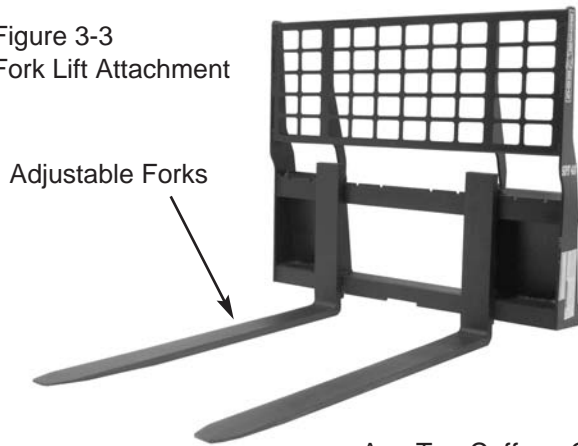

3-5 QUICK HITCH OPERATION

The quick hitch (Figure 3-4) is designed to allow easy mounting and dismounting of attachments from loader. With attachment on flat, level surface, mount as follows:

Tilt quick hitch slightly forward at top and slowly drive into attachment.

Hook quick hitch under top cuff on attachment and lift off ground using boom cylinders only.

Tilt quick hitch backward so that bottom of attachment will swing into position. Release spring-loaded pins into place behind hitch lug for operation.

To dismount the attachment:

Tilt quick hitch backward and rotate handles up to disengage pins. Reverse the mounting procedure.

⚠ CAUTION

ALWAYS CHECK TO INSURE THAT QUICK HITCH PINS ARE IN THE LATCHED POSITION BEFORE OPERATING LOADER OR ACCIDENTAL DISENGAGEMENT OF THE ATTACHMENT COULD RESULT.

3-6 TRANSPORTING

When transporting on road or highway, day or night, use tractor flashing warning lights unless prohibited by law. Carry load as low as possible maintaining adequate ground clearance and good visibility. Reduce tractor ground speed when carrying a load. Take extra care when traveling over rough terrain or on slopes.

⚠ CAUTION

WHEN TRANSPORTING A LOAD, KEEP THE ATTACHMENT AS LOW AS POSSIBLE TO RESIST TIPPING IN CASE A WHEEL DROPS IN A RUT.

Figures 3-4 A, B, C, & D
Quick Hitch Attachment

A. Top Cuff Quick Hitch Tilted Forward

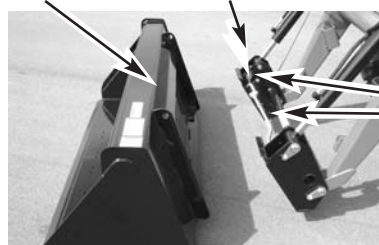

B. Drive Into Attachment



C. Raise And Roll Back Attachment



D. Lower Spring-Loaded Pins

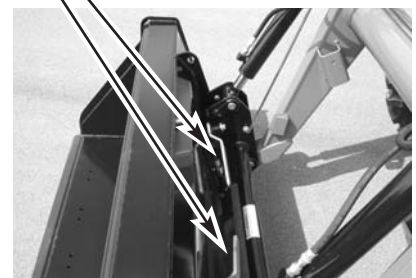

SECTION IV MAINTENANCE

4-1 MAINTENANCE CHECK LIST

Perform scheduled maintenance as outlined below. Lower machine to ground, turn off tractor, and set parking brake before doing maintenance inspections or work. All bolts should be torqued as recommended in torque chart unless otherwise indicated.

WARNING

THE LOADER CAN FALL FROM HYDRAULIC SYSTEM FAILURE. TO AVOID SERIOUS INJURY OR DEATH, SECURELY SUPPORT LOADER BEFORE WORKING UNDERNEATH.

BEFORE EACH USE

1. Inspect hydraulic lines and fittings for wear or leaks. Repair or replace if needed.
2. Inspect all pivot pins for wear. Make certain clevis pins and cotter pins are installed to retain each pivot pin.
3. Check all bolts for tightness.
4. Perform BEFORE EACH USE lubrication per paragraph 4-2.
5. During operation, listen for abnormal sounds which might indicate loose parts or other damage.

AFTER EACH USE

1. Clean all debris from machine, especially cylinder rods and affixed safety decals. Replace any missing or illegible decals.
2. Inspect loader for worn or damaged components. Repair or replace before next use. Any replacement components installed during repair shall include the components current safety decals specified by the manufacturer to be affixed to the component.
3. Store loader in a dry place.

Figure 4-1 Lubrication Points

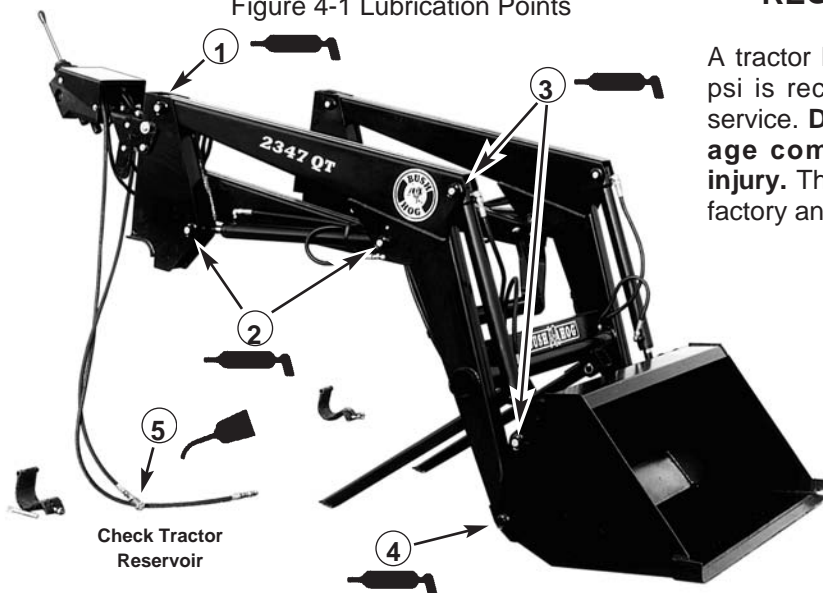

4-2 LUBRICATION (Figure 4-1)

NOTE

The multi-purpose grease referenced in this section is an NLGI grade 2 type grease.

BEFORE EACH USE

1. Boom Pivot Pins - Apply multi-purpose grease to each fitting (1 fitting each side)
2. Boom Cylinders - Apply multi-purpose grease to each fitting (2 fittings each cylinder)
3. Bucket Cylinders - Apply multi-purpose grease to each fitting (2 fittings each cylinder)
4. Bucket Pivot Pin - Apply multi-purpose grease to each fitting (1 fitting each side)
5. Hydraulic Oil - Cycle boom and bucket cylinders 2 or 3 times before each use, then check hydraulic oil level in tractor reservoir.

CAUTION

USE A PIECE OF CARDBOARD OR WOOD RATHER THAN HANDS AND WEAR EYE PROTECTION WHEN SEARCHING FOR HYDRAULIC LEAKS. ESCAPING HYDRAULIC OIL UNDER PRESSURE CAN PENETRATE SKIN. IF OIL IS INJECTED INTO SKIN, IT MUST BE SURGICALLY REMOVED WITHIN A FEW HOURS BY A DOCTOR OR GANGRENE MAY RESULT.

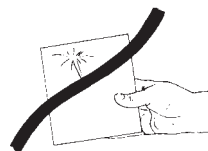

4-3 HYDRAULIC SYSTEM PRESSURE REQUIREMENTS

A tractor hydraulic system pressure setting of 2500 psi is recommended for maximum efficiency and service. **Do not exceed 3000 psi as this will damage components possibly causing serious injury.** The Bush Hog control valve is pre-set at the factory and should not be adjusted.

4-4 TROUBLESHOOTING

Troubleshooting procedures are listed in Table 4-1. If the problem cannot be solved or replacement parts are necessary, contact your authorized Bush Hog

dealer. Please have ready your machine name, model number, serial number, purchase date and exact cause or description of problem.

TABLE 4-1 TROUBLESHOOTING PROCEDURES

PROBLEM	POSSIBLE CAUSE	REMEDY
Loader slow and/or will not dump.	Hydraulic oil too heavy. Oil filter plugged. Hydraulic pump worn. Oil line restricted or leaking. Quick couplers not properly connected. Control valve does not shift properly. Air in hydraulic system. Cylinder leaks internally. Faulty valve.	Change to proper oil. Clean or replace filter. Repair or replace pump. Check all hoses and tubes for leaks, damage or restrictions. Replace damaged or restricted hoses or tube lines. Check connection - Replace if necessary. Inspect clean, repair or replace valve. Cycle lift cylinders and bucket cylinders several times to free system of air. Replace seals. Repair or replace valve.
Loader chatters or vibrates when raising or lowering.	Air in hydraulic system. Oil level too low.	Cycle lift cylinders and bucket cylinders. Add oil as required.
Oil leaks.	Damaged fittings or hoses. Loose connections. Worn or damaged O-ring or wiper seal in cylinder rod end. Worn or damaged O-rings in valve.	Replace damaged parts. Tighten fittings. Install a seal repair kit. Install an O-ring repair kit.
Insufficient lift capacity.	Load is greater than boom lift capacity. Internal boom cylinder leakage. Improper hydraulic valve operation.	Check loader specifications. Check tractor system. Replace any worn parts and install a seal repair kit. Repair or replace valve.
Slow leakdown.	Worn control valve. Worn cylinder piston seals.	Have authorized Bush Hog dealer replace seals. Have authorized Bush Hog dealer replace seals.
Excessive wear on bottom of bucket and wear pads.	Float position not used while operating loader.	Use float position provided on valve.
Hydraulic cylinders inoperative.	Hose from control valve improperly connected.	Refer to plumbing diagrams in Section V.
Pump operating continually on closed center tractor hydraulic system.	Hydraulic control valve relief stuck open. Hydraulic control valve relief set too low.	See your tractor manual for proper adjustment or Bush Hog dealer for loader valve. (3000 PSI is maximum pressure relief setting recommended)
Loader lift and bucket tilt controls do not work according to decal.	Hoses improperly connected.	Refer to plumbing diagrams in Section V and correct hose connections.
Valve noisy and/or hot.	Open center control valve on closed center tractor.	Install closed center plug on optional valve.
Tractor loads/pump squeals.	Closed center control valve on open center tractor.	Install open center plug on optional valve.

SECTION V ASSEMBLY

CAUTION

THE FOLLOWING SAFETY PRECAUTIONS SHOULD BE THOROUGHLY UNDERSTOOD BEFORE ATTEMPTING MACHINE ASSEMBLY.

1. Do not lift heavy parts or assemblies. Use crane, jack, tackle, fork trucks, or other mechanical devices.
2. Select an area for assembly that is clean and free of any debris which might cause persons working on the assembly to trip.
3. Arrange parts to be assembled neatly in the work area and have tools or other mechanical assisting devices in easy reach.
4. Inspect all parts and assemblies thoroughly and remove any sharp edges, grease, oil, or dirt which might cause pieces to slip when handling.
5. Preview the assembly instructions in your operator's manual before proceeding further.
6. If the assembly instructions call for parts or assemblies to be blocked up, use only blocking material that is in good condition and is capable of handling the weight of the assembly to be blocked. Also insure that the blocking material is on a clean, dry surface.
7. Never put hands on any other part of body under blocked up assemblies if at all possible.
8. Always wear goggles or safety glasses when hammering, grinding or drilling metal parts.
9. If the assembly calls for welding or cutting, be sure that there are no flammable materials close at hand and that bystanders have taken necessary precautions.

AFTER COMPLETING ANY ASSEMBLY STEP, THOROUGHLY READ THE NEXT STEP IN THE ASSEMBLY INSTRUCTIONS BEFORE PROCEEDING WITH THAT STEP.

10. After completing assembly, thoroughly inspect the machine to be sure that all nuts, bolts, hydraulic fittings or any other fastened assemblies have been thoroughly tightened.
11. After completing assembly, be sure that all safety locking devices or guards are in place.
12. Before operating the machine, thoroughly read the operation section of this manual.
13. Before operating, read the maintenance section of this manual to be sure that any parts requiring lubrication such as gearboxes are full to avoid any possible damage.

14. Wear personal protective equipment such as, but not limited to, protection for eyes, ears, feet, hands, lungs and head when assembling the equipment. Do not wear loose clothing or jewelry that may catch on equipment moving parts.

BEFORE OPERATING THE EQUIPMENT, IF YOU HAVE ANY QUESTIONS REGARDING THE PROPER ASSEMBLY OR OPERATION, CONTACT YOUR AUTHORIZED BUSH HOG DEALER OR REPRESENTATIVE.

5-1 MAINFRAME ASSEMBLY

BE SURE ALL STEPS ARE COMPLETED IN SUPPLEMENTAL BRACKET INSTRUCTIONS BEFORE BEGINNING FINAL ASSEMBLY.

A. Bolt the front mount, side mounts and cross tube (some models do not require cross tubes) to the tractor according to the supplemental instructions furnished with the mounting kit.

B. Attach level indicator rod guide to right hand side of boom using 1/4" bolt, flat washers and lock nut as shown in Figure 5-1. Do not tighten so as to prevent indicator rod from pivoting.

C. Slide indicator rod through guide and secure other end to outside of quick hitch with flat washer and cotter pin. Check to ensure that indicator rod will pivot freely.

D. Install elbow fitting (supplied in bag of hardware) to the rod end of each bucket cylinder and attach corresponding hoses.

E. Raise rear of loader to install parking stands as shown.(Figure 5-2)

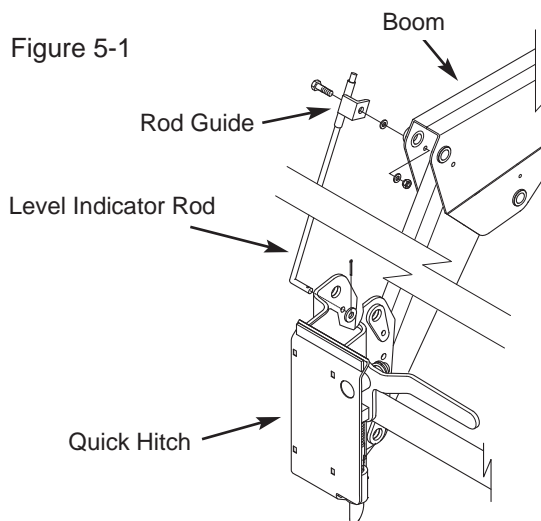
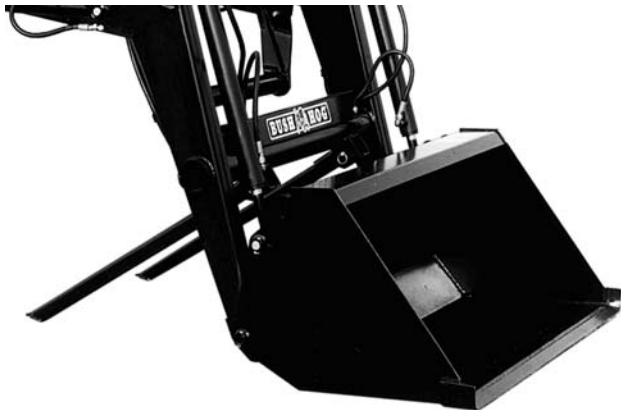

Figure 5-1

CAUTION

INSURE THAT METHOD OF RAISING THE FRAME ASSEMBLY PROVIDES SECURE SUPPORT AT ALL TIMES TO PREVENT IT FALLING ONTO FEET, HANDS, ETC.

Figure 5-2 Parking Stands Installed



F. Connect hydraulic hoses to loader as shown in Figure 5-3. If optional hydraulic valve is used, refer to paragraphs 5-2 and 5-3 for valve and stand assembly instructions.

G. Install cuffs, pins, washers, bolts, and nuts as shown. (Figure 5-4)

Figure 5-4 Cuff Arrangement

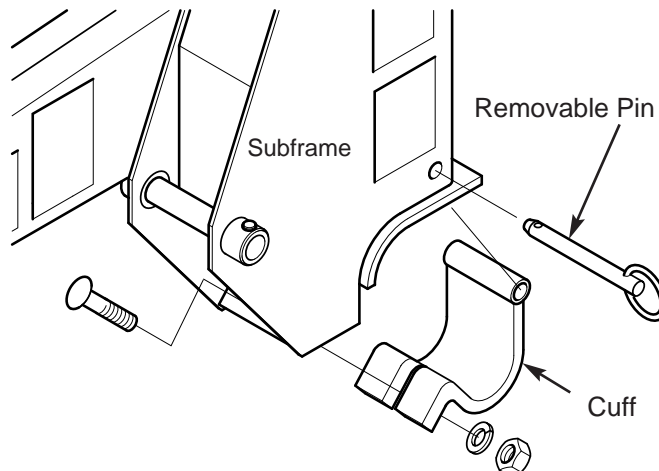

Figure 5-3 Tractor Hydraulic Kit

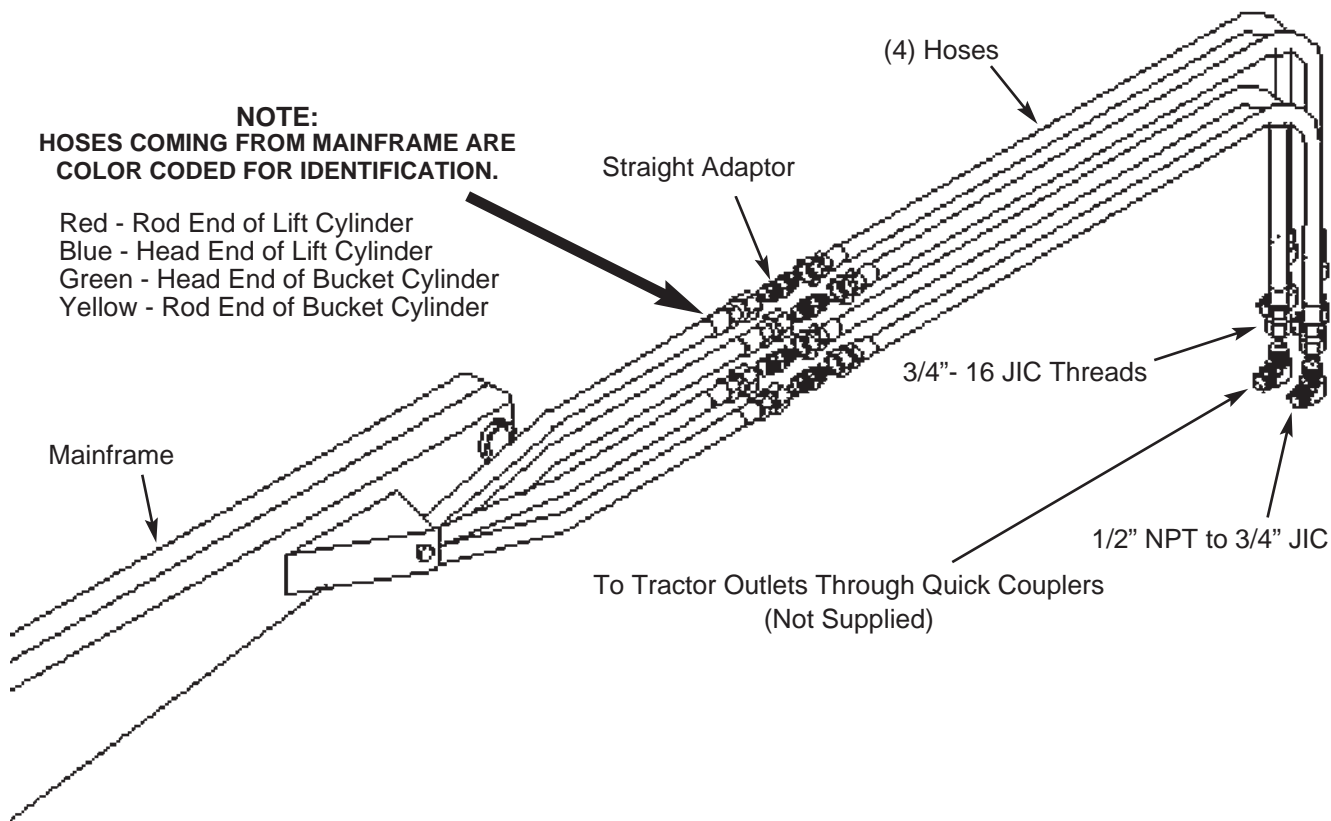
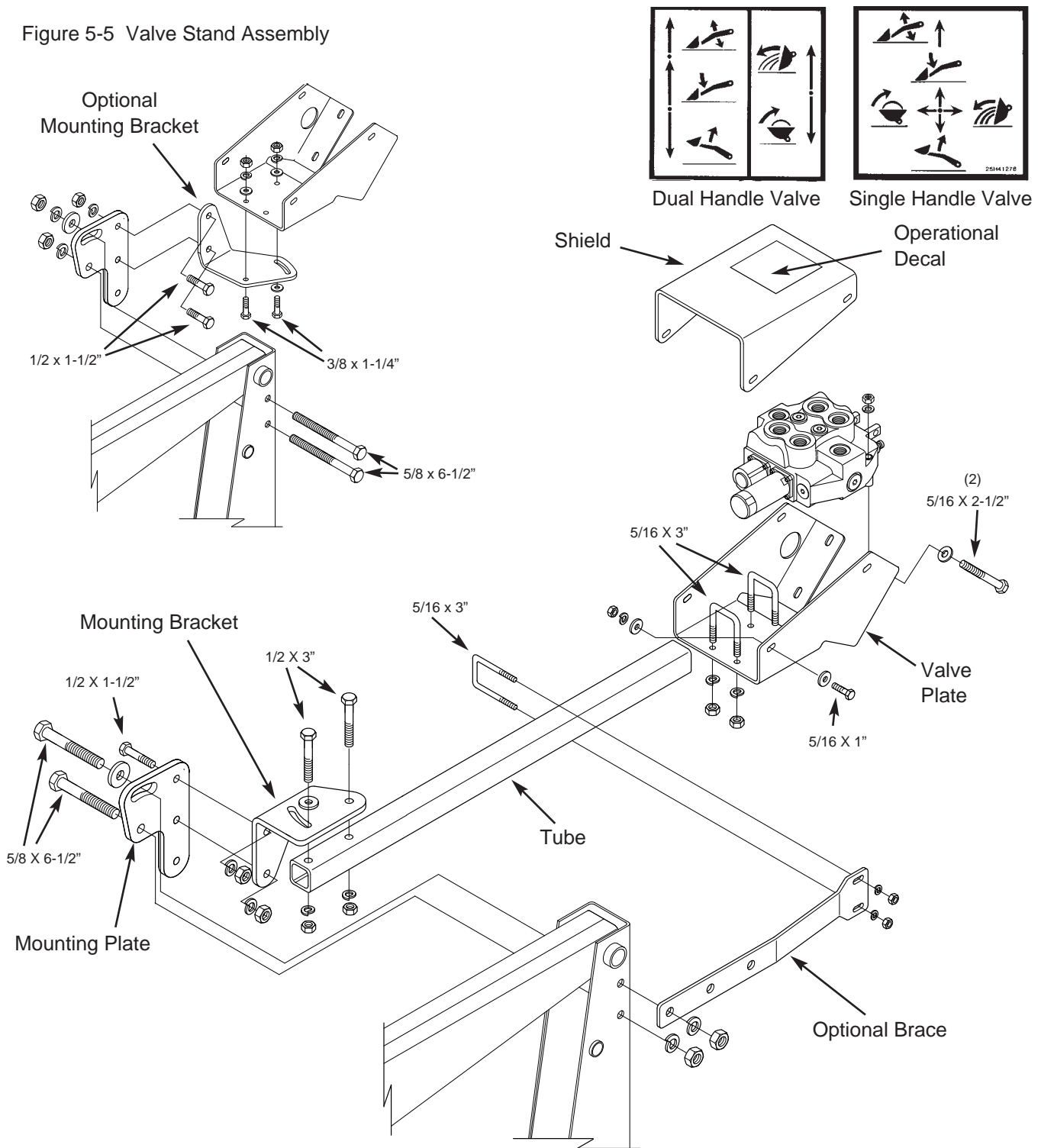

Figure 5-5 Valve Stand Assembly



5-2 OPTIONAL HYDRAULIC VALVE STAND ASSEMBLY (Figure 5-5)

A. Attach mounting plate to loader frame using two $5/8 \times 6-1/2"$ bolts, flatwashers, lockwashers and nuts. Note that this plate may be rotated 180° to allow three different mounting tube heights.

B. Attach mounting bracket to plate using two $1/2 \times 1-1/2"$ bolts, lockwashers and nuts.

C. Attach mounting tube to bracket using $1/2 \times 3"$ bolts, lockwashers and nuts. The slotted hole also requires a flatwasher, as shown.

D. Attach valve plate to tube using U-bolts, lockwashers and nuts. **Note: Mounting tube may be too long for tractor being mounted and should be cut to desired length.**

5-3 OPTIONAL HYDRAULIC VALVE PLUMBING INSTRUCTIONS

A. Mount valve assembly to valve plate using fasteners provided.

B. Plumb valve as shown in Figure 5-5.

C. This valve is set for an open center tractor hydraulic system. If tractor has a closed center hydraulic system, a closed center plug must be installed.

D. Remove open center plug.

E. Install the closed center plug furnished with valve. Note: When converting to closed center configuration open center plug is removed from valve and installed in sleeve of closed center plug assembly.

F. Install valve operational decal on valve shield.

HOSE COLOR CODES

Figure 5-6 Walvoil Hydraulic Control Valve

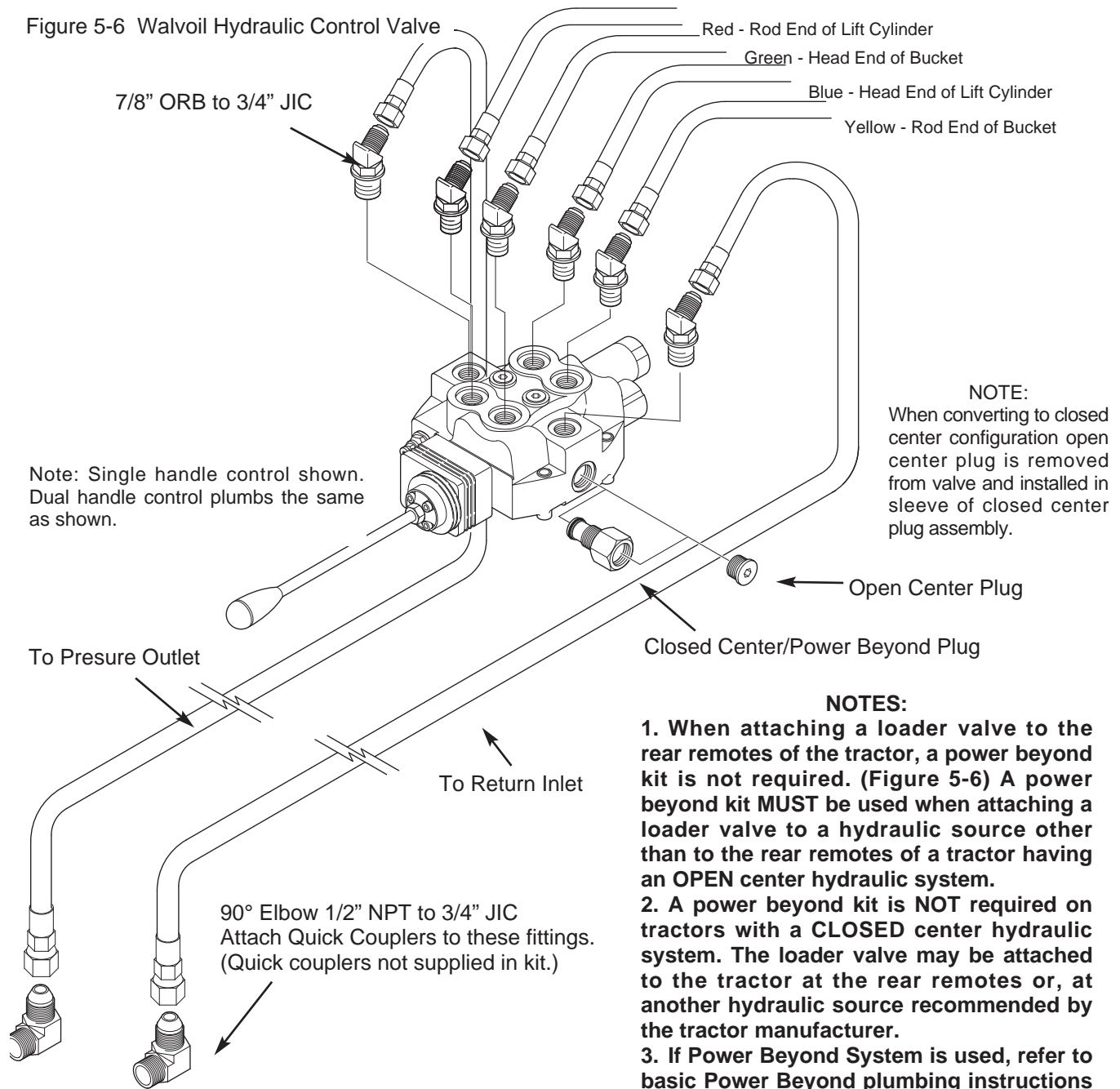

NOTE:
When converting to closed center configuration open center plug is removed from valve and installed in sleeve of closed center plug assembly.

Note: Single handle control shown. Dual handle control plumbs the same as shown.

NOTES:

1. When attaching a loader valve to the rear remotes of the tractor, a power beyond kit is not required. (Figure 5-6) A power beyond kit **MUST** be used when attaching a loader valve to a hydraulic source other than to the rear remotes of a tractor having an OPEN center hydraulic system.
2. A power beyond kit is **NOT** required on tractors with a CLOSED center hydraulic system. The loader valve may be attached to the tractor at the rear remotes or, at another hydraulic source recommended by the tractor manufacturer.
3. If Power Beyond System is used, refer to basic Power Beyond plumbing instructions on the following page. (Figure 5-7)
4. If the tractor has a Pressure Flow Compensated System (PFC) - the loader valve **MUST** be connected to the **TRACTOR REMOTES**.

5-4 BASIC POWER BEYOND PLUMBING INSTRUCTIONS

IMPORTANT

When loader hydraulics are disconnected from tractor hydraulics, hoses A & B must be connected to complete tractor hydraulic circuit. FAILURE TO DO THIS WILL CAUSE SERIOUS DAMAGE TO TRACTOR HYDRAULIC SYSTEM.

Figure 5-7

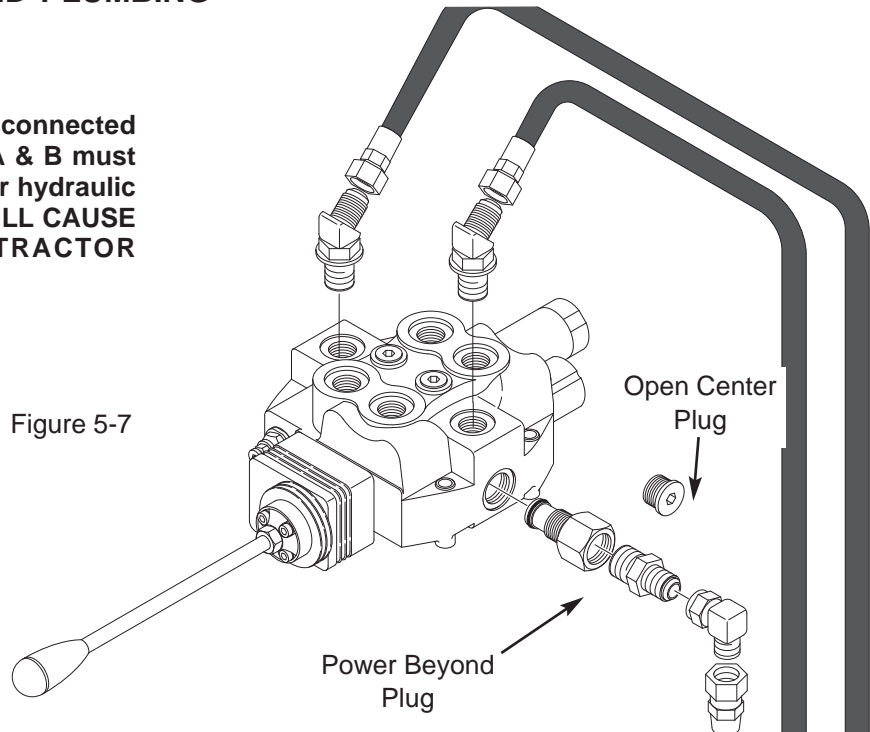

NOTE

More detailed assembly instructions are furnished with individual Power Beyond Kits.

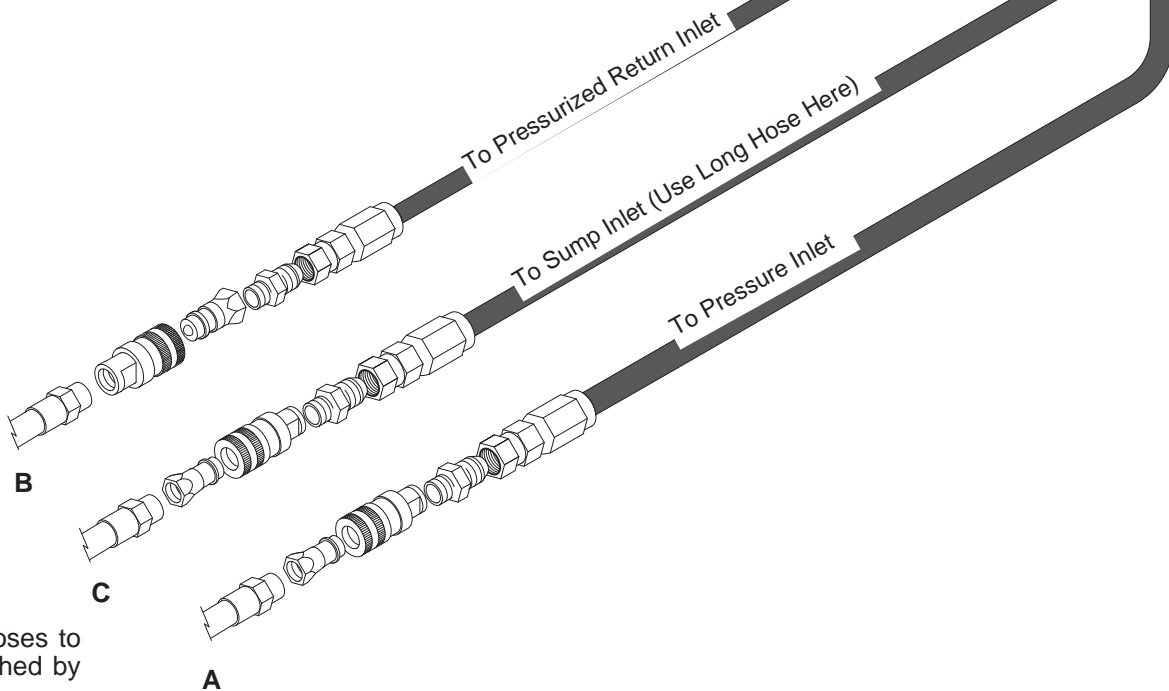

These hoses to be furnished by dealer.

5-5 FORK LIFT OPTION

Raise the positioning lock pins at the top of each fork. Place fork in the middle of the frame over the notch in the lower edge. Slide forks to desired positions and lower pins to lock forks in place.

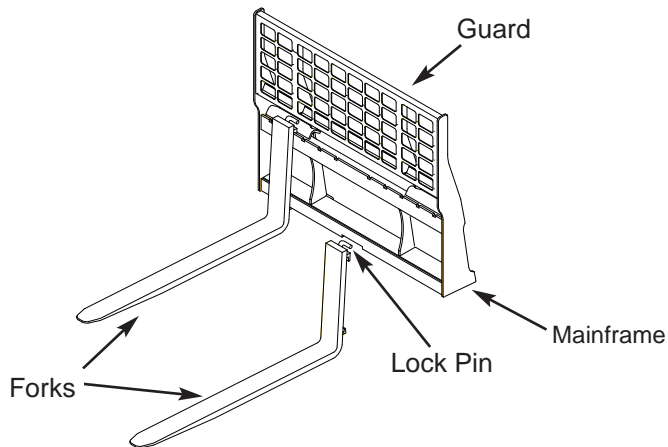

5-6 BALE SPEAR OPTION

Insert long spear into top of frame and fasten with eccentric nut as shown. Tapered side of nut must be against frame. **Torque nut to 470 -505 ft./lbs.** Insert short spears into tubes at bottom of frame and tighten lock bolts.

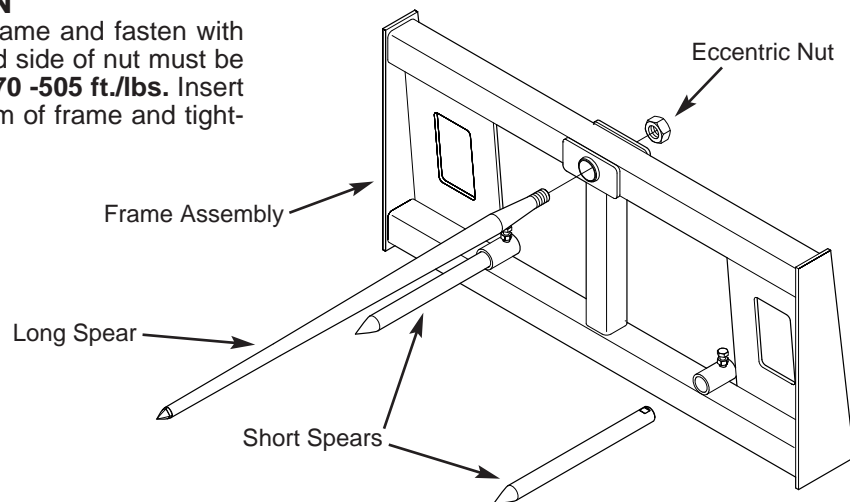

5-7 TINE TEETH

Fasten tine teeth to bucket with fasteners provided as shown.

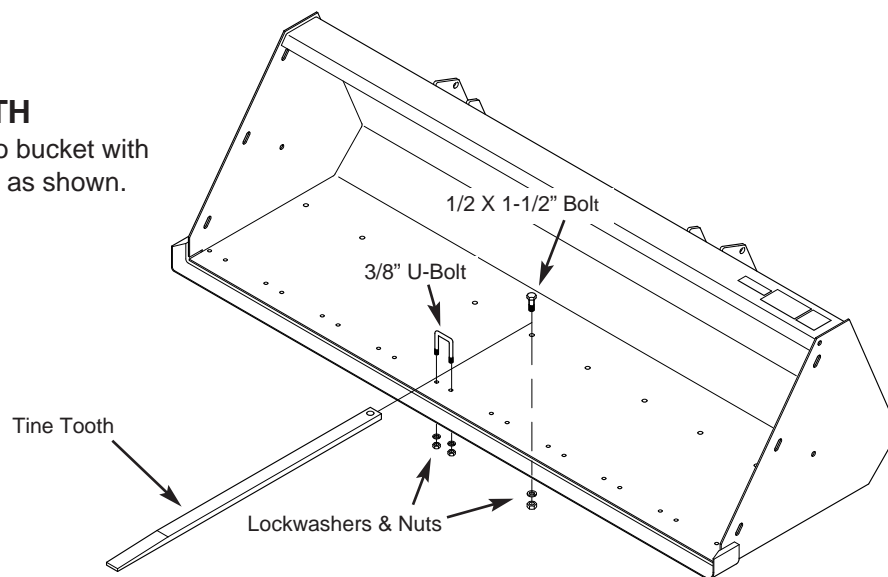



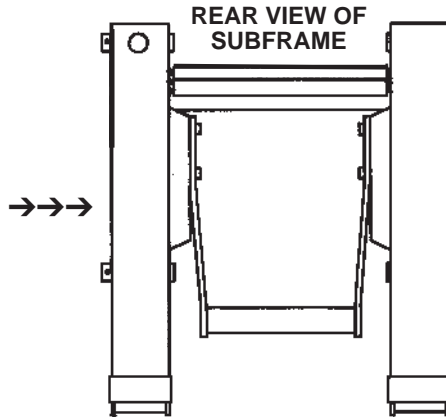

SAFETY DECALS

To promote safe operation, Bush Hog supplies safety decals on all products manufactured. Because damages can occur to safety decals either through shipment, use or reconditioning, Bush Hog will, upon request, provide safety decals for any of our products in the field at no charge. Contact your authorized Bush Hog dealer for more information.

Decals 25H46070, 25H46071, 25H46010 and 25H46012 are located on the left side of the subframe. Other decals are located on attachments (Bucket, Fork Lift, Bale Spear).



CAUTION	TO AVOID SERIOUS INJURY OR DEATH:	
	<ul style="list-style-type: none"> • READ OPERATOR'S MANUAL AND DECALS BEFORE OPERATING & FOLLOW ALL PRECAUTIONS. (CONTACT DEALER OR BUSH HOG FOR REPLACEMENT) • ALLOW NO CHILDREN OR UNQUALIFIED PERSONS TO OPERATE EQUIPMENT. • ROPS (ROLLOVER PROTECTIVE SYSTEM) AND SEAT BELT EQUIPPED TRACTOR IS RECOMMENDED FOR OPERATOR USE IN ALL LOADER OPERATIONS. • ADD RECOMMENDED WHEEL BALLAST OR REAR WEIGHT FOR STABILITY. 	<ul style="list-style-type: none"> • MOVE WHEELS TO WIDEST RECOMMENDED SETTINGS TO INCREASE STABILITY. • OPERATE LOADER ONLY FROM "OPERATOR'S SEAT". • STOP ENGINE, LOWER ARMS, RELIEVE ALL HYDRAULIC PRESSURE AND LOCK BRAKES BEFORE LEAVING OPERATOR'S SEAT. • DO NOT STAND, WORK, OR ALLOW OTHERS UNDER RAISED LOADER. • MOVE AND TURN TRACTOR AT LOW SPEEDS.
		<ul style="list-style-type: none"> • CARRY LOADER ARMS AT A LOW POSITION DURING TRANSPORT. • DO NOT LIFT OR CARRY ANYONE ON LOADER OR ON BUCKETS, FORKS, OR ATTACHMENTS. • OPERATOR SHOULD WEAR SAFETY HARD HAT, SAFETY GLASSES, SAFETY SHOES AND OTHER P.P.E. AVOID WEARING LOOSE CLOTHING OR JEWELRY THAT MAY CATCH IN MOVING PARTS.
		<small>25H46071</small>

WARNING

TO AVOID SERIOUS INJURY OR DEATH:
<ul style="list-style-type: none"> ★ UNLOAD ONLY ON A LEVEL SURFACE ★ KEEP BYSTANDERS CLEAR OF WORK AREA WHEN LOADING AND UNLOADING BALES
<small>Part No. 79104</small>

25H46071

CAUTION
 
TO AVOID INJURIES:
<ul style="list-style-type: none"> ★ READ OPERATOR'S MANUAL AND FOLLOW ALL SAFETY, OPERATING AND SERVICE INSTRUCTIONS (CONTACT DEALER FOR MANUALS). ★ BE CAREFUL DURING LOADING, TRANSPORTING, AND STACKING TO MINIMIZE ROLLING BALES AND TRACTOR TIP OVER. ★ ROPS (ROLL OVER PROTECTION SYSTEM) AND SEAT BELT EQUIPPED TRACTORS ARE RECOMMENDED FOR BALE SPEAR OPERATION. ★ DO NOT ALLOW RIDERS ON TRACTORS OR SPEAR. ★ AVOID LOADING/UNLOADING BALES ON SLOPING OR UNEVEN SURFACES. ★ AVOID TRANSPORTING WITH BALES RAISED HIGH. KEEP BALES LOW TO SURFACE WHILE MOVING. ★ TRANSPORT BALES AT LOW SPEEDS AND REDUCE SPEEDS ON CURVES, HILLS, ROUGH GROUND OR WHEN TURNING.
<small>79103</small>



79104

CAUTION
<p>BE SURE TO PURGE ALL THE AIR FROM THE HYDRAULIC SYSTEM BEFORE ATTEMPTING TO RAISE OR LOWER THIS MACHINE. REFER TO OWNERS MANUAL FOR FURTHER DETAILS.</p>
<small>24-6-423</small>

24-6-423

WARNING
<p>THESE FORKS ARE NOT INTENDED FOR USE WITH LARGE OBJECTS SUCH AS ROUND HAY BALES OR OTHER ITEMS WHICH MAY ROLL BACKWARDS AND FALL, CAUSING INJURY TO THE OPERATOR.</p>
<p>Lift only objects that are within the stated lift capacity of the loader. Refer to your owner's manuals for the loader and for this fork attachment for load limits and other safety considerations.</p>

62779

WARNING
 
TO AVOID SERIOUS INJURY OR DEATH FROM LARGE ROUND HAY BALE HANDLING,
<ol style="list-style-type: none"> 1. USE BUSH HOG BALE SPEAR OR BALE RETAINING HANDLER ATTACHMENTS. 2. DO NOT USE BUCKETS, FORKS, OR OTHER ATTACHMENTS WITHOUT BALE RETAINING DEVICES. 3. DO NOT USE LOADER FOR HANDLING LARGE, HEAVY OBJECTS SUCH AS LOGS, TANKS, ETC. <p>HANDLING LARGE HEAVY OBJECTS CAN BE EXTREMELY DANGEROUS DUE TO:</p> <ul style="list-style-type: none"> • DANGER OF ROLLING THE TRACTOR OVER. • DANGER OF UPENDING THE TRACTOR. • DANGER OF THE OBJECT ROLLING OR SLIDING DOWN THE LOADER ARMS ONTO THE OPERATOR.
<small>25H46010</small>

25H46010

WARNING
  
RAISED LOADER OR BOOM CAN FALL FROM HYDRAULIC SYSTEM FAILURE. TO AVOID SERIOUS INJURY OR DEATH,
<ul style="list-style-type: none"> • BLOCK UP OR SECURELY SUPPORT LOADER AND BOOM BEFORE WORKING UNDERNEATH. • PURGE ALL AIR FROM HYDRAULIC SYSTEM BEFORE ATTEMPTING TO RAISE OR LOWER LOADER OR BOOM. • STAND CLEAR IF LOWERING OR RAISING LOADER OR BOOM. • DO NOT USE HAND OR SKIN TO CHECK FOR HYDRAULIC LEAKS. USE CARDBOARD OR WOOD. WEAR EYE PROTECTION. • HIGH PRESSURE OIL LEAKS CAN PENETRATE SKIN CAUSING SERIOUS INJURY AND GANGRENE. CONSULT A PHYSICIAN IMMEDIATELY. • LOWER THE LOADER OR BOOM AND RELEASE HYDRAULIC PRESSURE BEFORE LOOSENING FITTINGS. • REFER TO OWNERS MANUAL FOR DETAILS.
<small>25H46070</small>

25H46070

WARNING
 
TO AVOID SERIOUS INJURY OR DEATH,
<ul style="list-style-type: none"> • DO NOT LIFT OR CARRY ANYONE ON BUCKETS, FORKS, SPEARS OR ANY OTHER PORTIONS OF THE LOADER OR LOADER ATTACHMENTS. <p>INADVERTENT MOVEMENT OF THE LOADER OR ATTACHMENT COULD RESULT IN SERIOUS INJURY OR DEATH.</p> <ul style="list-style-type: none"> • AVOID CONTACT WITH ELECTRICAL POWER LINES BY LOADER OR ATTACHMENTS
<small>25H46012</small>

25H46012

TORQUE SPECIFICATIONS

Proper torque for American fasteners used on Bush Hog equipment.
Recommended Torque in Foot Pounds (Newton Meters).*

AMERICAN Bolt Head Markings

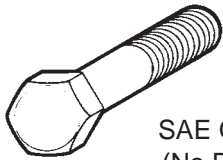

SAE Grade 2
(No Dashes)

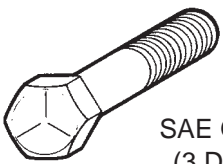

SAE Grade 5
(3 Dashes)

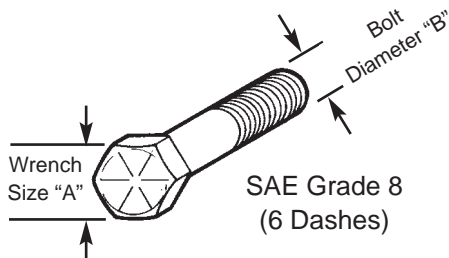

SAE Grade 8
(6 Dashes)

WRENCH SIZE (IN.) "A"	BOLT DIAMETER (IN.) "B" AND THREAD SIZE	SAE GRADE 2	SAE GRADE 5	SAE GRADE 8
7/16	1/4 - 20 UNC	6 (7)	8 (11)	12 (16)
7/16	1/4 - 28 UNF	6 (8)	10 (13)	14 (18)
1/2	5/16 - 18 UNC	11 (15)	17 (23)	25 (33)
1/2	5/16 - 24 UNF	13 (17)	19 (26)	27 (37)
9/16	3/8 - 16 UNC	20 (27)	31 (42)	44 (60)
9/16	3/8 - 24 UNF	23 (31)	35 (47)	49 (66)
5/8	7/16 - 14 UNC	32 (43)	49 (66)	70 (95)
5/8	7/16 - 20 UNF	36 (49)	55 (75)	78 (106)
3/4	1/2 - 13 UNC	49 (66)	76 (103)	106 (144)
3/4	1/2 - 20 UNF	55 (75)	85 (115)	120 (163)
7/8	9/16 - 12 UNC	70 (95)	109 (148)	153 (207)
7/8	9/16 - 18 UNF	79 (107)	122 (165)	172 (233)
15/16	5/8 - 11 UNC	97 (131)	150 (203)	212 (287)
15/16	5/8 - 18 UNF	110 (149)	170 (230)	240 (325)
1-1/8	3/4 - 10 UNC	144 (195)	266 (360)	376 (509)
1-1/8	3/4 - 16 UNF	192 (260)	297 (402)	420 (569)
1-5/16	7/8 - 9 UNC	166 (225)	430 (583)	606 (821)
1-5/16	7/8 - 14 UNF	184 (249)	474 (642)	668 (905)
1-1/2	1 - 8 UNC	250 (339)	644 (873)	909 (1232)
1-1/2	1 - 12 UNF	274 (371)	705 (955)	995 (1348)
1-1/2	1 - 14 UNF	280 (379)	721 (977)	1019 (1381)
1-11/16	1-1/8 - 7 UNC	354 (480)	795 (1077)	1288(1745)
1-11/16	1-1/8 - 12 UNF	397 (538)	890 (1206)	1444 (1957)
1-7/8	1-1/4 - 7 UNC	500 (678)	1120 (1518)	1817 (2462)
1-7/8	1-1/4 - 12 UNF	553 (749)	1241 (1682)	2013 (2728)
2-1/16	1-3/8 - 6 UNC	655 (887)	1470 (1992)	2382 (3228)
2-1/16	1-3/8 - 12 UNF	746 (1011)	1672 (2266)	2712 (3675)
2-1/4	1-1/2 - 6 UNC	870 (1179)	1950 (2642)	3161 (4283)
2-1/4	1-1/2 - 12 UNF	979 (1327)	2194 (2973)	3557 (4820)

METRIC

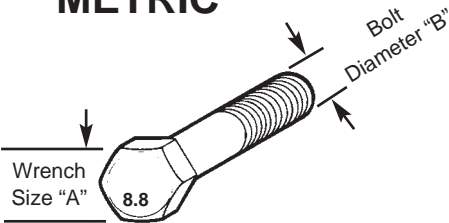

Numbers appearing on bolt heads indicate ASTM class.

Proper torque for metric fasteners used on Bush Hog equipment.
Recommended torque in foot pounds (newton Meters).*

WRENCH SIZE (mm) "A"	BOLT DIA. (mm) "B"	ASTM 4.6	ASTM 8.8	ASTM 9.8	ASTM 10.9
8	5	1.8 (2.4)		5.1 (6.9)	6.5 (8.8)
10	6	3 (4)		8.7 (12)	11.1 (15)
13	8	7.3 (10)		21.1 (29)	27 (37)
16	10	14.5 (20)		42 (57)	53 (72)
18	12	25 (34)	74 (100)	73 (99)	93 (126)
21	14	40 (54)	118 (160)	116 (157)	148 (201)
24	16	62 (84)	167 (226)	181 (245)	230 (312)
30	20	122 (165)	325 (440)		449 (608)
33	22		443 (600)		611 (828)
36	24	211 (286)	563 (763)		778 (1054)
41	27		821 (1112)		1138 (1542)
46	30	418 (566)	1119 (1516)		1547 (2096)

*Use 75% of the specified torque value for plated fasteners. Use 85% of the specified torque values for lubricated fasteners.



BUSH HOG[®]
Performance You Can Count OnSM

P.O. Box 1039 • Selma, AL 36702-1039
Telephone (334) 874-2700 • www.bushhog.com

Free Manuals Download Website

<http://myh66.com>

<http://usermanuals.us>

<http://www.somanuals.com>

<http://www.4manuals.cc>

<http://www.manual-lib.com>

<http://www.404manual.com>

<http://www.luxmanual.com>

<http://aubethermostatmanual.com>

Golf course search by state

<http://golfingnear.com>

Email search by domain

<http://emailbydomain.com>

Auto manuals search

<http://auto.somanuals.com>

TV manuals search

<http://tv.somanuals.com>