

BUSH HOG®

GEARDRIVE HAY MOWERS Models HM2007, HM2008, & HM2009

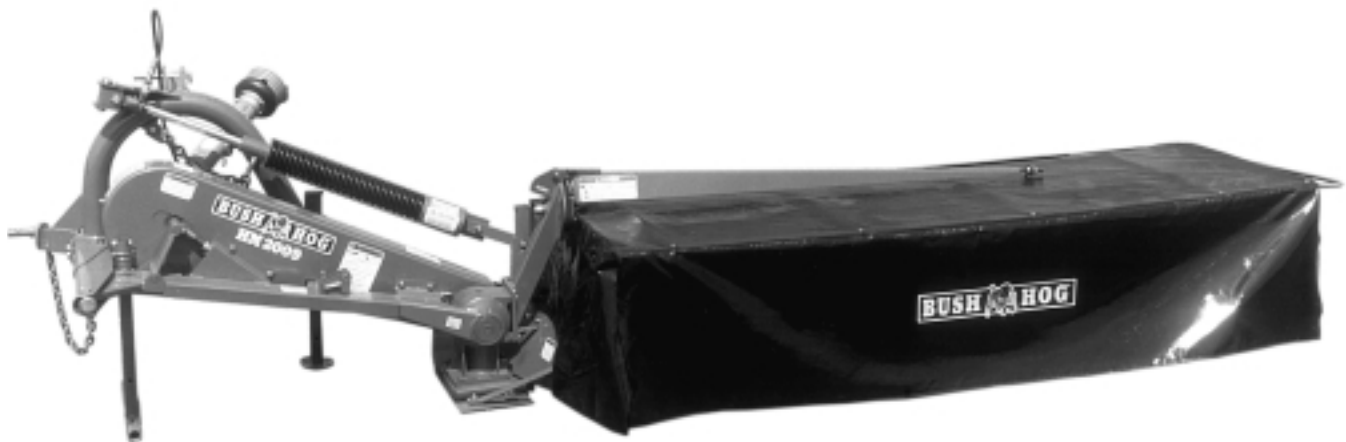

Operator's Manual

ASSEMBLY ● OPERATION ● MAINTENANCE

CONGRATULATIONS!

You have invested in the best implement of its type on the market today.

The care you give your Bush Hog implement will greatly determine your satisfaction with its performance and its service life. We urge a careful study of this manual to provide you with a thorough understanding of your new implement before operating, as well as suggestions for operation and maintenance.

If your manual should become lost or destroyed, Bush Hog will be glad to provide you with a new copy. Order from Bush Hog, P. O. Box 1039, Selma, Alabama 36702-1039.

As an authorized Bush Hog dealer, we stock genuine Bush Hog parts which are manufactured with the same precision and skill as our original equipment. Our trained service personnel are well informed on methods required to service Bush Hog equipment, and are ready and able to help you.

Should you require additional information or assistance, please contact us.

YOUR AUTHORIZED
BUSH HOG DEALER

BECAUSE BUSH HOG MAINTAINS AN ONGOING PROGRAM OF PRODUCT IMPROVEMENT, WE RESERVE THE RIGHT TO MAKE IMPROVEMENTS IN DESIGN OR CHANGES IN SPECIFICATIONS WITHOUT INCURRING ANY OBLIGATION TO INSTALL THEM ON UNITS PREVIOUSLY SOLD.

BECAUSE OF THE POSSIBILITY THAT SOME PHOTOGRAPHS IN THIS MANUAL WERE TAKEN OF PROTOTYPE MODELS, PRODUCTION MODELS MAY VARY IN SOME DETAIL. IN ADDITION, SOME PHOTOGRAPHS MAY SHOW SHIELDS REMOVED FOR PURPOSES OF CLARITY. **NEVER OPERATE** THIS IMPLEMENT WITHOUT ALL SHIELDS IN PLACE.

HAY MOWER

TABLE OF CONTENTS

SECTION	PAGE	SECTION	PAGE
Warranty	2	Stabilizer.....	25
Dealer Preparation Check List	3	Lifting Height	25
Safety Alert Symbols	4	Transport - Unhitching	27
Safety Precautions	5	Maintenance.....	29
Federal Laws and Regulations.....	6	Lubrication.....	31
Machine Measurements	7	Optional Equipment.....	35
Technical Data.....	8	Direction For Repair	41
General Safety Instructions	11	Problem/Fault Analysis & Corrections.....	44
Preparation For Use	19	Winter Storage	45
Mounting.....	21	Conversion Chart & Lubricants	46
PTO Shaft.....	23	Assembly Instructions	47
Height Of The Suspension	25	Safety Decals	57

RETAIL CUSTOMER'S RESPONSIBILITY UNDER THE BUSH HOG WARRANTY

It is the Retail Customer and/or Operator's responsibility to read the Operator's Manual, to operate, lubricate, maintain and store the product in accordance with all instructions and safety procedures. Failure of the operator to read the Operator's Manual is a misuse of this equipment.

It is the Retail Customer and/or Operator's responsibility to inspect the product and to have any part(s) repaired or replaced when continued operation would cause damage or excessive wear to other parts or cause a safety hazard.

It is the Retail Customer's responsibility to deliver the product to the authorized Bush Hog Dealer, from whom he purchased it, for service or replacement of defective parts which are covered by warranty. Repairs to be submitted for warranty consideration must be made within forty-five (45) days of failure.

It is the Retail Customer's responsibility for any cost incurred by the Dealer for traveling to or hauling of the product for the purpose of performing a warranty obligation or inspection.

BUSH HOG® LIMITED WARRANTY



Bush Hog warrants to the original purchaser of any new Bush Hog equipment, purchased from an authorized Bush Hog dealer, that the equipment be free from defects in material and workmanship for a period of one (1) year for non-commercial, state, and municipalities' use and ninety (90) days for commercial use from date of retail sale. The obligation of Bush Hog to the purchaser under this warranty is limited to the repair or replacement of defective parts.

Replacement or repair parts installed in the equipment covered by this limited warranty are warranted for ninety (90) days from the date of purchase of such part or to the expiration of the applicable new equipment warranty period, whichever occurs later. Warranted parts shall be provided at no cost to the user at an authorized Bush Hog dealer during regular working hours. Bush Hog reserves the right to inspect any equipment or parts which are claimed to have been defective in material or workmanship.

DISCLAIMER OF IMPLIED WARRANTIES & CONSEQUENTIAL DAMAGES

Bush Hog's obligation under this limited warranty, to the extent allowed by law, is in lieu of all warranties, implied or expressed, **INCLUDING IMPLIED WARRANTIES OF MERCHANTABILITY AND FITNESS FOR A PARTICULAR PURPOSE** and any liability for incidental and consequential damages with respect to the sale or use of the items warranted. Such incidental and consequential damages shall include but not be limited to: transportation charges other than normal freight charges; cost of installation other than cost approved by Bush Hog; duty; taxes; charges for normal service or adjustment; loss of crops or any other loss of income; rental of substitute equipment, expenses due to loss, damage, detention or delay in the delivery of equipment or parts resulting from acts beyond the control of Bush Hog.

THIS LIMITED WARRANTY SHALL NOT APPLY:

1. To vendor items which carry their own warranties, such as engines, tires, and tubes.
2. If the unit has been subjected to misapplication, abuse, misuse, negligence, fire or other accident.
3. If parts not made or supplied by Bush Hog have been used in connection with the unit, if, in the sole judgement of Bush Hog such use affects its performance, stability or reliability.
4. If the unit has been altered or repaired outside of an authorized Bush Hog dealership in a manner which, in the sole judgement of Bush Hog, affects its performance, stability or reliability.
5. To normal maintenance service and normal replacement items such as gearbox lubricant, hydraulic fluid, worn blades, or to normal deterioration of such things as belts and exterior finish due to use or exposure.
6. To expendable or wear items such as teeth, chains, sprockets, belts, springs and any other items that in the company's sole judgement is a wear item.

NO EMPLOYEE OR REPRESENTATIVE OF BUSH HOG IS AUTHORIZED TO CHANGE THIS LIMITED WARRANTY IN ANY WAY OR GRANT ANY OTHER WARRANTY UNLESS SUCH CHANGE IS MADE IN WRITING AND SIGNED BY BUSH HOG'S SERVICE MANAGER, POST OFFICE BOX 1039, SELMA, ALABAMA 36702-1039.



Record the model number, serial number and date purchased. This information will be helpful to your dealer if parts or service are required.

MODEL NUMBER _____

MAKE CERTAIN THE WARRANTY REGISTRATION CARD HAS BEEN FILED WITH BUSH HOG/
SELMA, ALABAMA

SERIAL NUMBER _____

DATE OF RETAIL SALE _____

DEALER PREPARATION CHECK LIST

HAY MOWER

BEFORE DELIVERING MACHINE — The following check list should be completed.
Use the Operator's Manual as a guide.

- 1. Assembly completed.
- 2. Gearbox filled with oil.
- 3. All fittings lubricated.
- 4. All shields in place and in good condition.
- 5. All fasteners torqued to specifications given in Torque Chart.
- 6. All decals in place and readable. (See decal page.)
- 7. Overall condition good (i.e. paint, welds)
- 8. Operators manual has been delivered to owner and he has been instructed on the safe and proper use of the mower.

Dealer's Signature _____

Purchaser's Signature _____

THIS CHECKLIST TO REMAIN IN OWNER'S MANUAL

It is the responsibility of the dealer to complete the procedures listed above before delivery of this implement to the customer.

Safety Alert Symbol



This Safety Alert Symbol means: “**ATTENTION! BECOME ALERT! YOUR SAFETY IS INVOLVED!**”

This symbol is used to call attention to safety precautions that should be followed by the operator to avoid accidents. When you see this symbol, carefully read the message that follows and heed its advice. Failure to comply with safety precautions could result in death or serious bodily injury.

Safety Signs *Signal Words*

The signal words **DANGER, WARNING, AND CAUTION** are used on the equipment safety signs. These words are intended to alert the viewer to the existence and the degree of hazard seriousness.

 **DANGER**

White letters on **RED**

This signal word indicates a potentially hazardous situation which, if not avoided, will result in death or serious injury.

 **WARNING**

Black letters on **ORANGE**

This signal word indicates a potentially hazardous situation which, if not avoided, could result in death or serious injury

It may also be used to alert against unsafe practices.

 **CAUTION**

Black letters on **YELLOW**

This signal word indicates a potentially hazardous situation exist which, if not avoided, may result in minor or moderate injury.

It may also be used to alert against unsafe practices.

IMPORTANT SAFETY PRECAUTIONS

This symbol is used to call attention to safety precautions that should be followed by the operator to avoid accidents. When you see this symbol, carefully read the message that follows and heed its advice. Failure to comply with safety precautions could result in serious bodily injury.



In addition to the design and configuration of equipment, hazard control and accident prevention are dependent upon the awareness, concern, prudence and proper training of personnel in the operation, transport, maintenance and storage of equipment. Lack of attention to safety can result in accident, personal injury, reduction of efficiency and worst of all—loss of life. Watch for safety hazards and correct deficiencies promptly. Use the following safety precautions as a general guide to safe operations when using this machine. Additional safety precautions are used throughout this manual for specific operating and maintenance procedures. Read this manual and review the safety precautions often until you know the limitations.

1. Read the Operator's Manual. Failure to read the Operator's Manual is considered a misuse of this equipment.
2. Become familiar with all the machine's controls and all the caution, warning and danger decals affixed to the machine before attempting to start or operate.
3. Before starting or operating the machine, make a walk around inspection and check for obvious defects such as loose mounting bolts and damaged components. Correct any deficiency before starting.
4. Do not allow children to operate the mower. Do not allow adults to operate it without proper instruction.
5. Do not carry passengers.
6. Keep the area of operation clear of all persons, particularly small children and pets. The operator should cease mowing whenever anyone comes within the operating area.
7. Clear the work area of objects which might be picked up and thrown.
8. Use a piece of cardboard or wood rather than hands to search for hydraulic leaks. Escaping hydraulic oil under pressure can penetrate skin. If fluid is injected into the skin, it must be surgically removed within a few hours by a doctor familiar with this form of injury or gangrene may result.
9. Do not operate without all guards and shields in place and in good condition.
10. Stop PTO, lower implement to ground, place tractor transmission in neutral or park, set parking brake, stop tractor engine, remove ignition key and wait for all motion to completely stop before leaving the tractor.
11. Keep hands and feet away from blades.
12. This mower is not to be operated in any area where people may be present unless all sides of the unit are enclosed by a curtain guard that is in good repair.
13. Wear personal protective equipment such as, but not limited to, protection for eyes, ears, feet, hands and head when operating or repairing the equipment. Do not wear loose clothing or jewelry that may catch on equipment moving parts.
14. When performing adjustments or maintenance on the mower, first lower it to the ground or block it securely at a workable height.
15. Never stand between tractor and mower while tractor is being backed to the cutter hitch.
16. Reduce speed when transporting mower to avoid bouncing and momentary loss of steering.
17. Use tractor flashing warning lights, day or night, when transporting mower on road or highways unless prohibited by law.
18. Pin transport lock to retain cutter bar in transport position.
19. Lower mower to ground before unhitching from tractor.
20. In the event that someone other than yourself will operate this equipment we firmly suggest that all SAFETY references be discussed prior to operation.
21. It is recommended that tractor be equipped with Rollover Protective System (ROPS) enclosed cab, and a seat belt.

IMPORTANT FEDERAL LAWS AND REGULATIONS* CONCERNING EMPLOYERS, EMPLOYEES AND OPERATIONS.

*(This section is intended to explain in broad terms the concept and effect of the following federal laws and regulations. It is not intended as a legal interpretation of the laws and should not be considered as such).

U.S. Public Law 91-596 (The Williams-Steiger Occupational and Health Act of 1970) OSHA

This Act Seeks:

"...to assure so far as possible every working man and woman in the nation safe and healthful working conditions and to preserve our human resources..."

DUTIES

Sec. 5 (a) Each employer—

- (1) shall furnish to each of his employees employment and a place of employment which are free from recognized hazards that are causing or are likely to cause death or serious physical harm to his employees;
- (2) shall comply with occupational safety and health standards promulgated under this Act.
 - (b) Each employee shall comply with occupational safety and health standards and all rules, regulations and orders issued pursuant to this Act which are applicable to his own actions and conduct.

OSHA Regulations

Current OSHA regulations state in part: "At the time of initial assignment and at least annually thereafter, the employer shall instruct every employee in the safe operation and servicing of all equipment with which the employee is, or will be involved." These will include (but are not limited to) instructions to:

Keep all guards in place when the machine is in operation;

Permit no riders on equipment;

Stop engine, disconnect the power source, and wait for all machine movement to stop before servicing, adjusting, cleaning or unclogging the equipment, except where the machine must be running to be properly serviced or maintained, in which case the employer shall instruct employees as to all steps and procedures which are necessary to safely service or maintain the equipment.

Make sure everyone is clear of machinery before starting the engine, engaging power, or operating the machine.

EMPLOYEE TRACTOR OPERATING INSTRUCTIONS:

1. Securely fasten your seat belt if the tractor has a ROPS.
2. Where possible, avoid operating the tractor near ditches, embankments, and holes.
3. Reduce speed when turning, crossing slopes, and on rough, slick, or muddy surfaces.
4. Stay off slopes too steep for safe operation.
5. Watch where you are going, especially at row ends, on roads, and around trees.
6. Do not permit others to ride.
7. Operate the tractor smoothly - no jerky turns, starts, or stops.
8. Hitch only to the drawbar and hitch points recommended by tractor manufacturers.
9. When tractor is stopped, set brakes securely and use park lock if available.

Child Labor Under 16 Years Old

Some regulations specify that no one under the age of 16 may operate power machinery. It is your responsibility to know what these regulations are in your own area or situation. (Refer to U.S. Dept. of Labor, Employment Standard Administration, Wage & Home Division, Child Labor Bulletin #102.)

Models HM2007 - HM2008 - HM2009

Model HM2007 - 3680 mm (145")
Model HM2008 - 4060 mm (160")
Model HM2009 - 4440 mm (175")

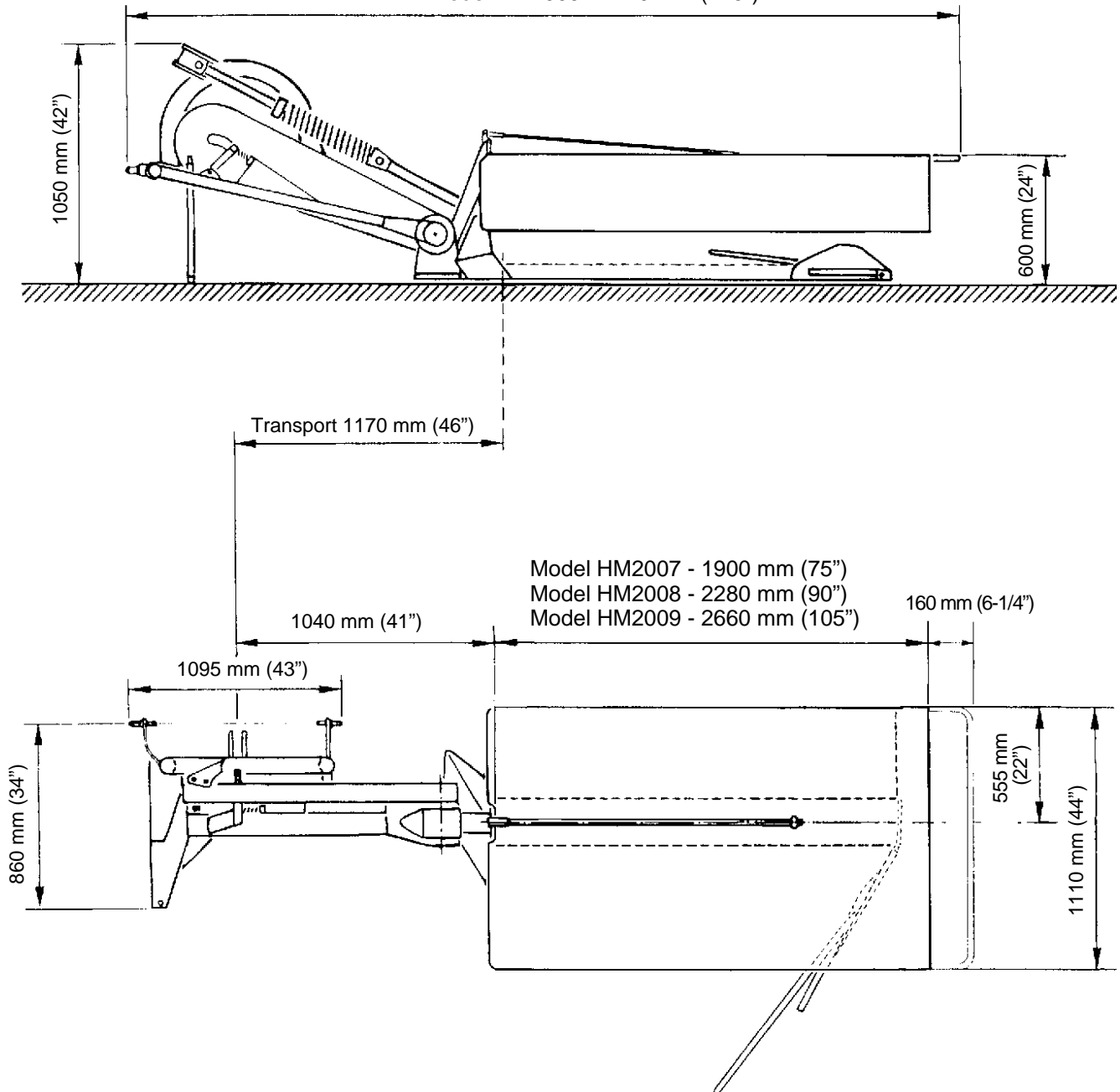

(All measurements are approximate and stated in mm and inches)

Technical Data (Conversion table - see page 46).

	Model HM2007	Model HM2008	Model HM2009
Weight kg (lb.)	415 (915)	440 (970)	465 (1025)
P.T.O. (Input speed) rpm	540	540	540
Power requirement, min. kW (HP)	30 (40)	33 (45)	37 (50)
P.T.O. shaft with overrun clutch	Standard	Standard	Standard
Number of discs pcs.	5	6	7
Number of knives pcs.	10	12	14
Speed of discs rpm	3000	3000	3000
Capacity: Drive speed km/h (mph)	6 - 25 (4-15)	6 - 25 (4-15)	6 - 25 (4-15)
Cutting width mm (in.)	2000 (79)	2400 (95)	2800 (110)
Stubble height mm (in.)	35 - 60 (1-3/8 - 2-3/8)	35 - 60 (1-3/8 - 2-3/8)	35 - 60 (1-3/8 - 2-3/8)
High cut skids (extra equipment) . . mm (in.)	65 - 110 (2-1/2 - 4-3/8)	65 - 110 (2-1/2 - 4-3/8)	65 - 110 (2-1/2 - 4-3/8)

Generally about supplementary equipment:

Machines are from the factory available with several options. See your Bush Hog dealer for more information on these options. This supplementary equipment and other extra equipment are mentioned on page 35.

Fitting to the tractor



The tractor must be of a suitable size, adhere to the local laws. Please note that side-mounted machines affect the stability of the tractor when driving in hilly conditions.

Couple the machine to the three-point suspension of the tractor. The tractor must have stabilizing chains on the lifting arms of the three-point suspension.

IMPORTANT

To achieve a good ground clearance under the machine when it is lifted in the three-point-suspension of the tractor the lifting arms must be able to be raised at least 950 mm (37-1/2") above the ground. Otherwise, the stated ground clearances, shown on page 25 , will be smaller. This especially applies to the wide machines **model HM2008 and HM2009.**

We reserve the right to make alterations without notice. We also make reservations as to the possible misprints in the manual.

Machine Identification

The machine serial number and manufacturer information can be found on the metal plate, as shown.



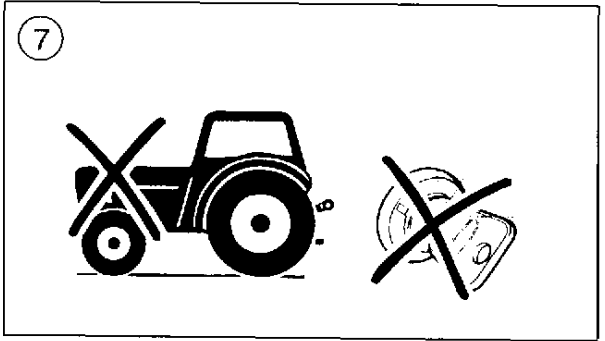
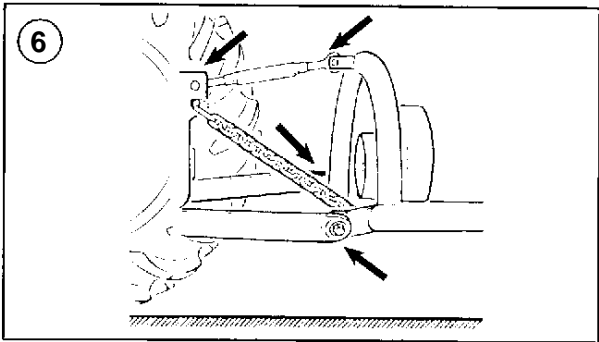
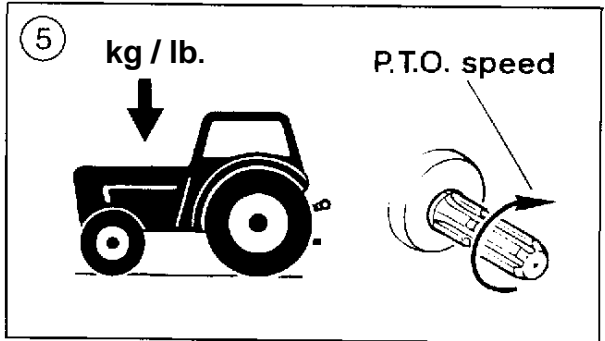
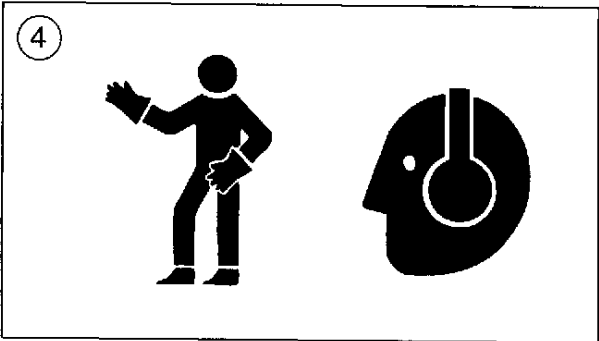
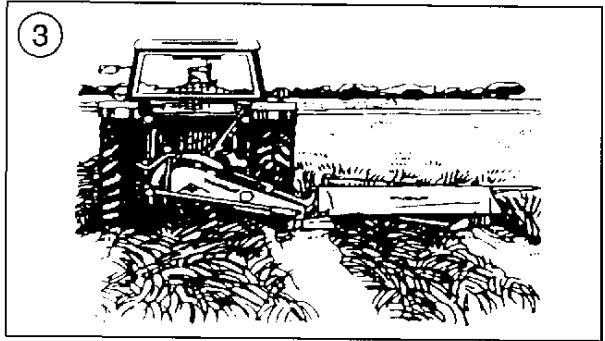
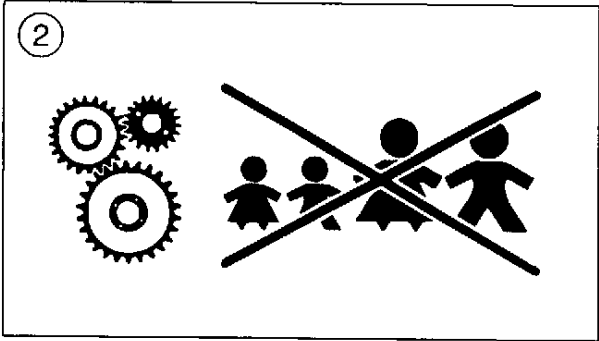
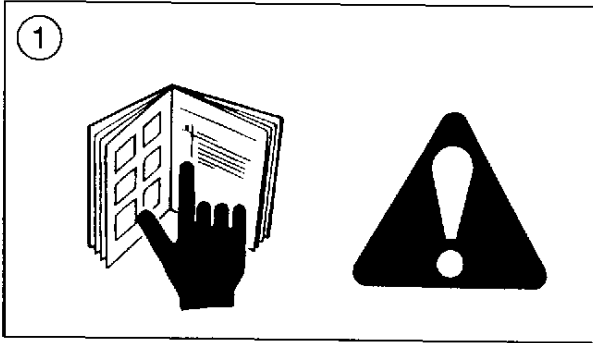

Safety

- ① **Any operator, repairer and owner** must be familiar with the warning instructions for the machine in this manual, before operations commence.

Always work carefully with agricultural machinery. Read through and observe the safety instructions in this manual. Safety is your responsibility.



Pay particular attention to this symbol. It means that there could be a serious hazard. It emphasizes precautions which have to be complied with in order to prevent accidents.

This symbol can be found throughout this manual and on the warning signs on the machine. They are for your safety and should be observed at all times.

General Safety Instructions

- ② **Be careful when other people or animals are close by!** Never start up the machine when people or animals are close or on the machine or tractor. **Never stand between the tractor wheels and the machine.**

Adhere to the local laws regarding children's minimum working age with agricultural machinery.

- ③ **Use of the machine.** The machine must only be used for harvest of common grass and grain crops. The machine must **not** be used for harvest of maize, lawn mowing in parks and cutting of hedges, neither in vertical or in horizontal position.

- ④ **Use personal protection devices.** Do not wear loose clothing which may catch in any of the moving parts. In dusty conditions a suitable mask must be used.

Take care of excessive sound level. Certain tractor/implement combinations, dependent on operating conditions, may generate a noise level in excess of 85 dB at the operators ear, even in a quiet cab. In these circumstances ear protection must be worn. Keep cab windows and doors **CLOSED** at all times to reduce noise level.

- ⑤ **The machine must only be coupled to a correctly sized tractor, and no other machines or implements must be coupled.** The weight of the tractor must correspond to the machine. Observe all local laws. Be careful that the tractor is not unbalanced when coupling.

Make sure that the tractor has the correct PTO. A machine intended for 540 rpm PTO input speed must **never** be coupled to a tractor with 1000 rpm PTO output speed.

- ⑥ **Coupling of tractor and machine** must be carried out as explained in the instructions. All lock pins must have locking retainers. Observe all local laws regarding road transport.

- ⑦ **Work in a safe way.** The tractor engine must **ALWAYS** be stopped and the ignition key removed before carrying out repairs, cleaning, lubricating or maintaining the machine.

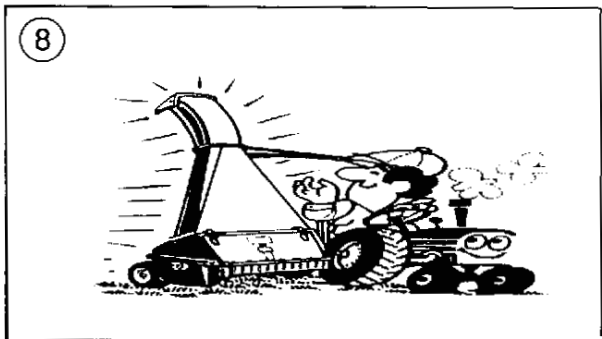
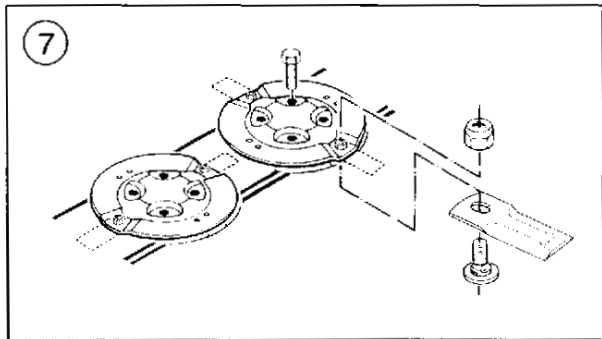
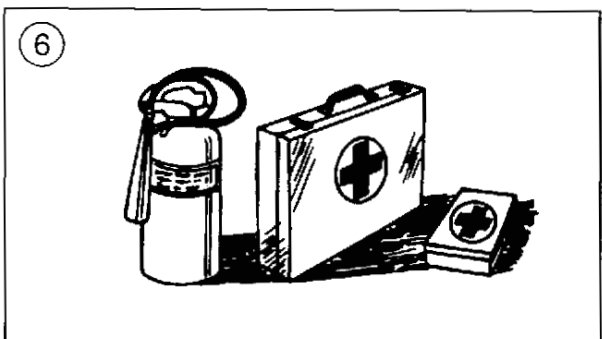
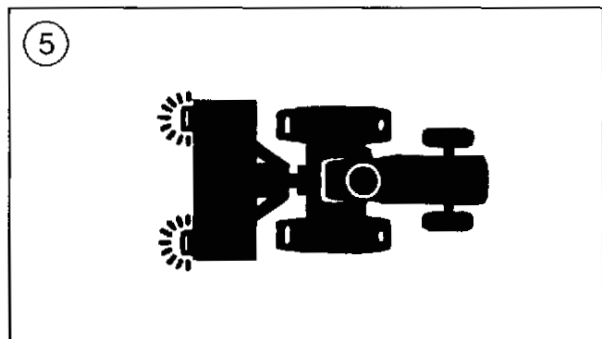
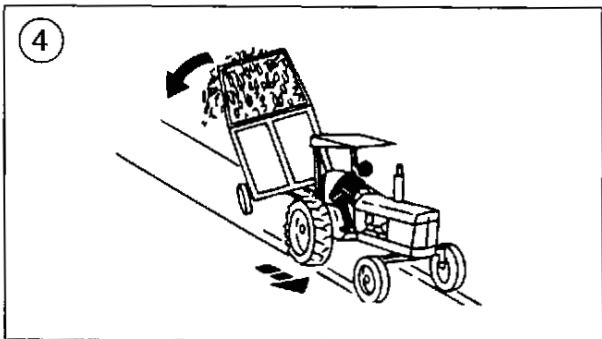
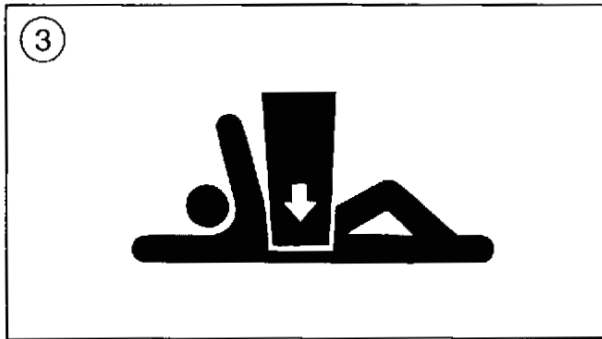
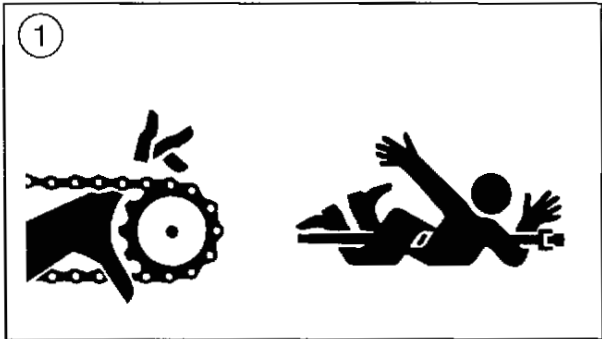

- ① **Safety guards.** Make sure that **ALL GUARDS** are in good order and fitted correctly. **Do no attempt to start the machine** before ensuring this.
Pay particular attention to the plastic guards of the PTO shaft. If damaged they must be replaced. The chain locks of the guards **MUST** always be fitted on a suitable place on the tractor and the machine to prevent the outer plastic guards turning.
- ② **Hydraulics.** Be very careful when dealing with hydraulics. Use eye protection and gloves. Escaping hydraulic oil under pressure might penetrate into the skin and cause serious infection. See a doctor if you have been exposed to injury.

Be watchful - damaged hydraulic hoses **must** be replaced immediately. **Never use** sealing tape or similar to repair the hoses. The hoses must be securely fixed. **All hydraulic hoses of the machine should be replaced at least every 4 years.**
- ③ **Remember when uncoupling, and when leaving tractor/machine.** The machine must be in the working position when uncoupling from the tractor. All hydraulic functions must be in neutral position, the machine must be lowered to the ground and be safely secured. Never allow children to play or be near agricultural machinery.
- ④ **Drive safely.** Be aware of your responsibility - carelessness or slovenliness can cause serious injury or death.

Before transporting on public roads, - always check that the machine is locked with cotter bolt and stop valve, that the coupling is in order, and that possible hydraulic systems and pawls are locked, see the manual of the machine.

Drive carefully. Reduce speed when turning and driving on uneven ground - take care that tractor/machine is not swinging and becoming unstable.

Please note that there is danger of overturning when working on slopes and in soft ground conditions.

The machine must not be used in situations that unbalances the tractor.
- ⑤ **Lighting.** It is the responsibility of the owner/operator to provide correct lights and reflectors on the machine, when it is being transported on public roads after dark. Observe the local laws.
- ⑥ **Safety equipment.** Always carry first aid equipment on the tractor. Also observe local laws concerning fire extinguishers. When working with hay or straw a fire extinguisher must be available at all times.
- ⑦ **Spare parts.** For safety reasons use only original spare parts. If injury occurs when using non-original spare parts the **Bush Hog** warranty is invalidated.
- ⑧ **Maintenance.** Take care that the machine is properly maintained and kept in good safe working condition. **Never** change the technical construction of the machine.



Model	Kg (lb.)
HM2007	415 (915)
HM2008	440 (970)
HM2009	465 (1025)

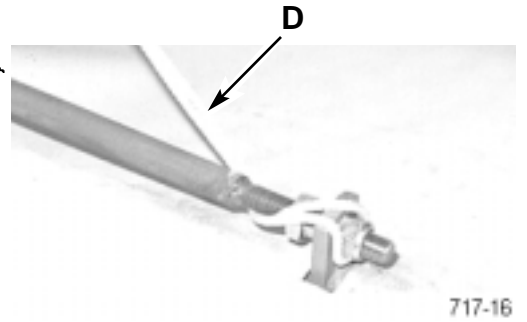
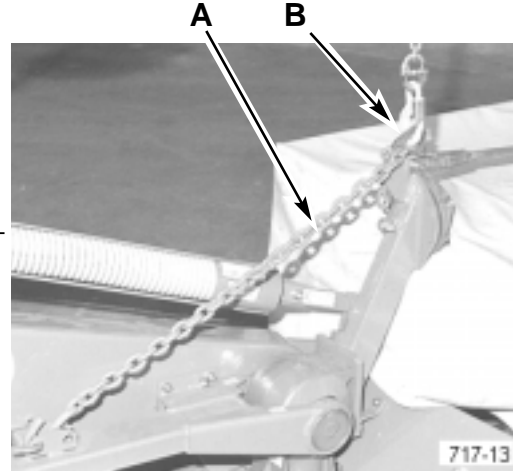
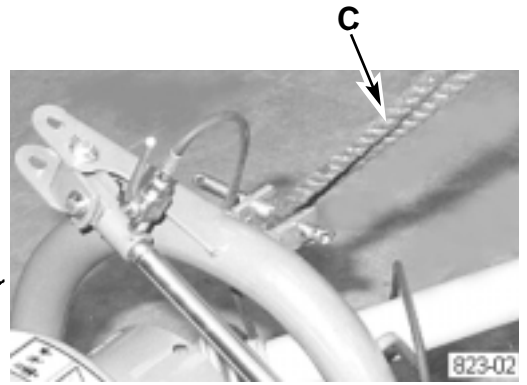
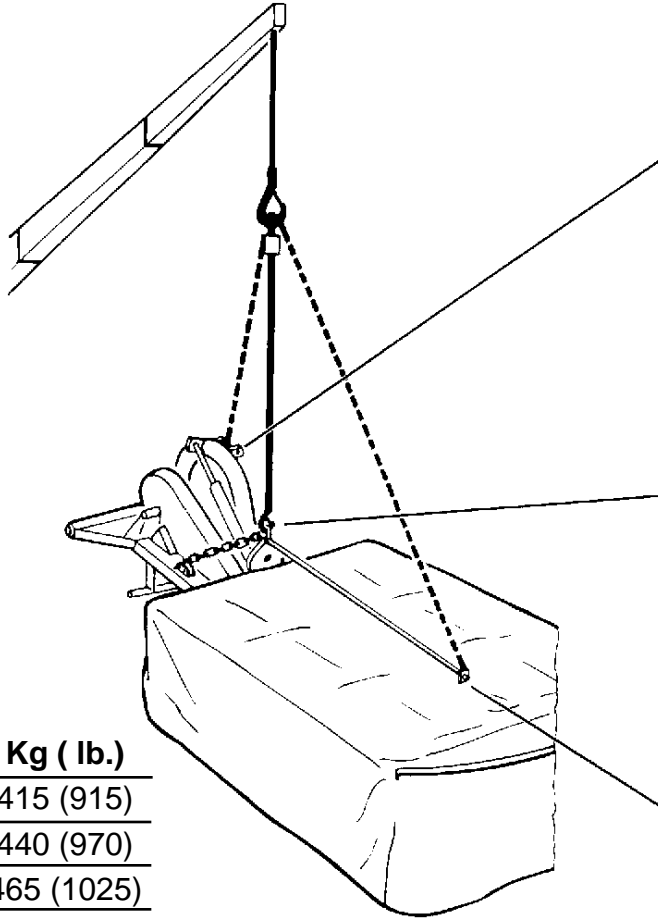

Safety instructions during crane lift



Only use approved crane material. The machine must be in working position. Weight is stated on the drawing. Make sure that crane straps are securely fastened before lifting. Use a guide rope (not shown) to keep the machine in position.

Be careful - make sure that nobody stand under or near the machine when it is being lifted.

Fasten chain (A) on the machine as shown. Lift the machine in crane bracket (B). Use support rope, minimum 6 mm (1/4") nylon rope at (C) and (D).

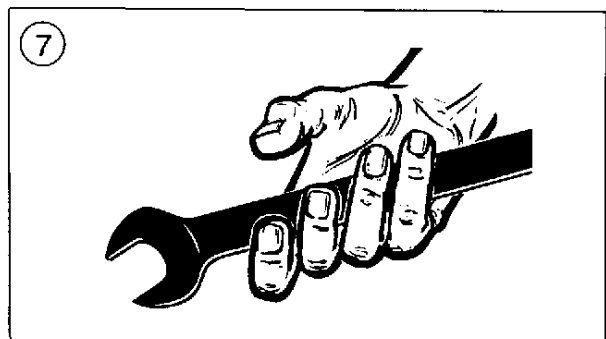
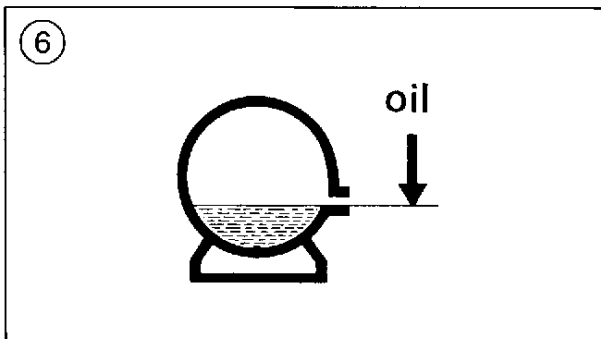
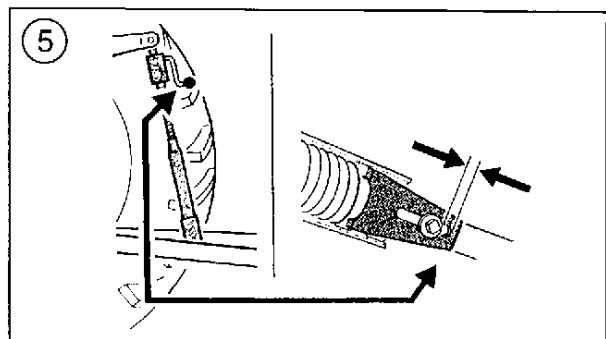
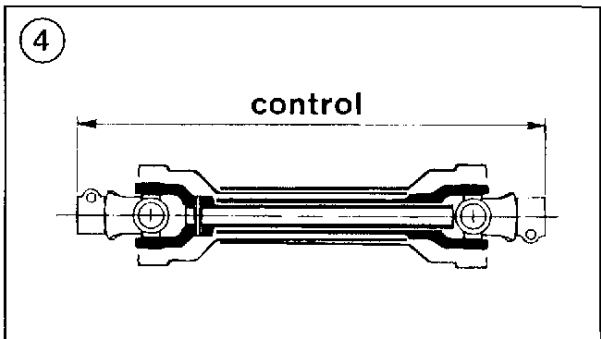
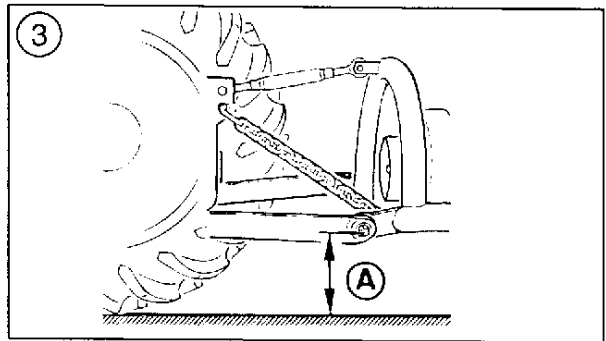
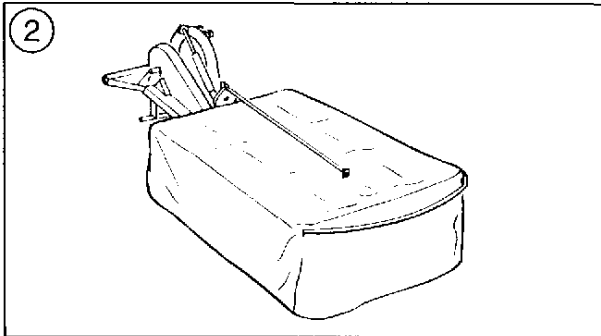
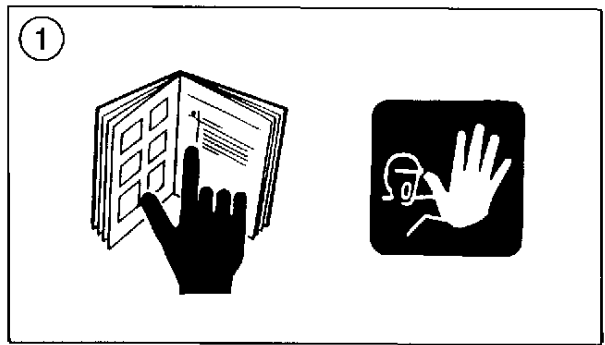

New Machine - be careful

- ① Read the directions for use. Great care must be taken, when starting up a new machine. Incorrect mounting, wrong operations, etc., can result in expensive repairs and loss of profits. **Bush Hog's** factory warranty is voided if the instructions of this manual are not adhered to.

NOTICE

Be especially attentive to the following when starting a new machine.

- ② Check that the machine is mounted correctly, and that it is not damaged. Machines with hydraulic stabilizer: Be certain that the hydraulic hoses are mounted so that they are long enough to allow for cylinder movements.

- ③ Be very careful when the machine is coupled to the tractor. If the coupling has not been carried out as explained in this manual the machine will not work correctly. Please note that the working height (A) is adjusted correctly. See page 24.

- ④ Be very careful when fitting the PTO shaft. If the PTO shaft is too short or too long it can cause great damage to the machine and tractor. Overriding clutch must be fitted on the shaft end of the machine. See pages 22 & 23.

If the PTO shafts of the machine are **noisy or vibrating** the fitting instructions must be repeated. See pages 22 & 23.

- ⑤ It is very important to check the area of motion of the stabilizer. If the adjustment has not been carried out as explained in this manual the machine will not work correctly. See page 24.

- ⑥ Before starting up a new machine it must be lubricated. Check that gearbox and cutterbar are filled with oil and that the oil level is correct. Use only the oil grades prescribed in the manual.

- ⑦ Check that all bolts at cutting discs and knives are tightened before the machine is started.

Check and re-tighten all bolts on the machine after the first hour of operation. This is especially important for quickly rotating parts. Also re-tighten after service work has been carried out.

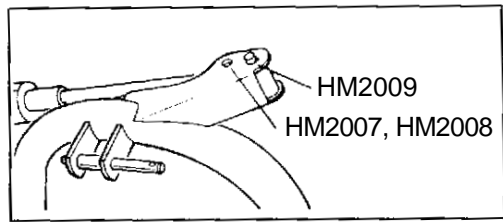

B

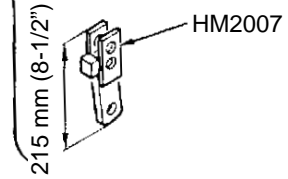
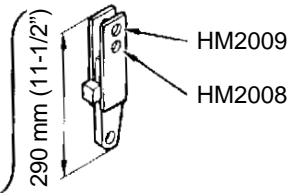

A

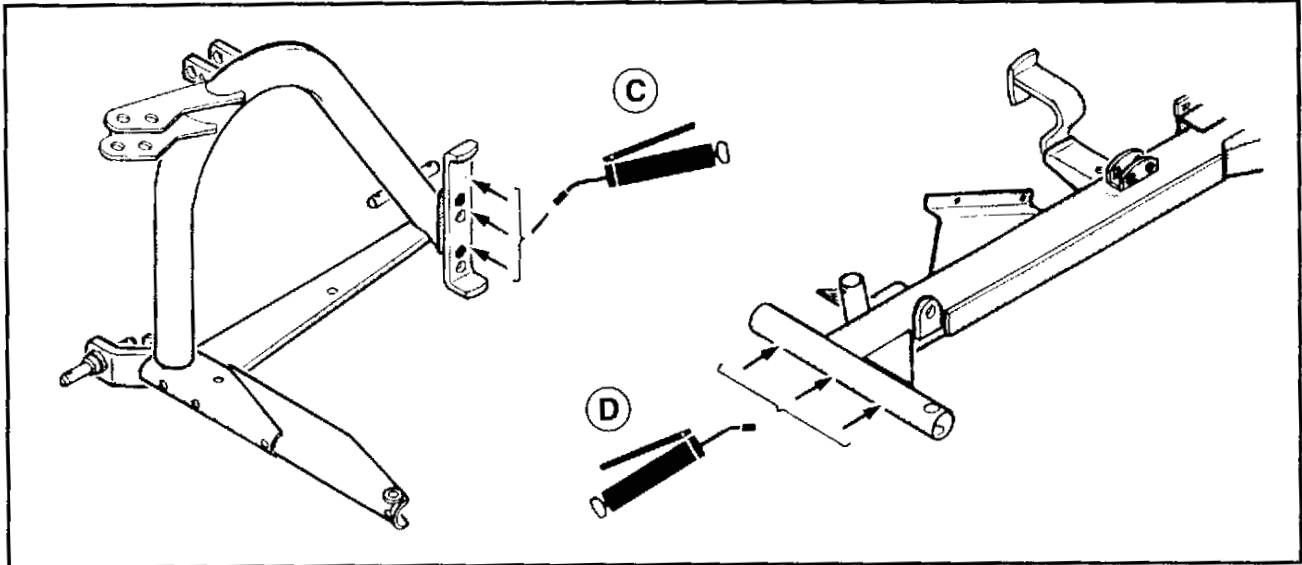
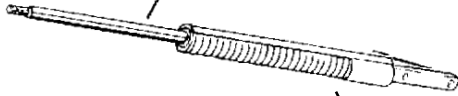

Preparation For Use

①

The photo shows a fully assembled machine. For shipping, the machine has been partly dismantled - reassembling is carried out according to the assembly instructions later in this manual.

Do the following before coupling the machine to the tractor:

- (A) Check that the stabilizer is equipped with the correct spring. The color of the spring must be as shown.

Model	Color
HM2007	Green
HM2008	Green
HM2009	Black

- (B) Check that the machine is equipped with the correct connecting link, and that the stabilizer is fitted in the correct hole.

NOTICE

If the above are not connected correctly the machine will not be able to work properly.

- (C) Lubricate the sliding surface of the lifting bracket with lithium grease or equivalent.
- (D) Lubricate the carrying tube of the swing bar with lithium grease or equivalent. The lubrication is easier to carry out by first removing the front support leg from the right hand hitch lug. The three point lift hitch may then be moved slightly forward and swung down and forward. After this the hitch can be turned to the left, so that the carrying tube can be lubricated at full length.

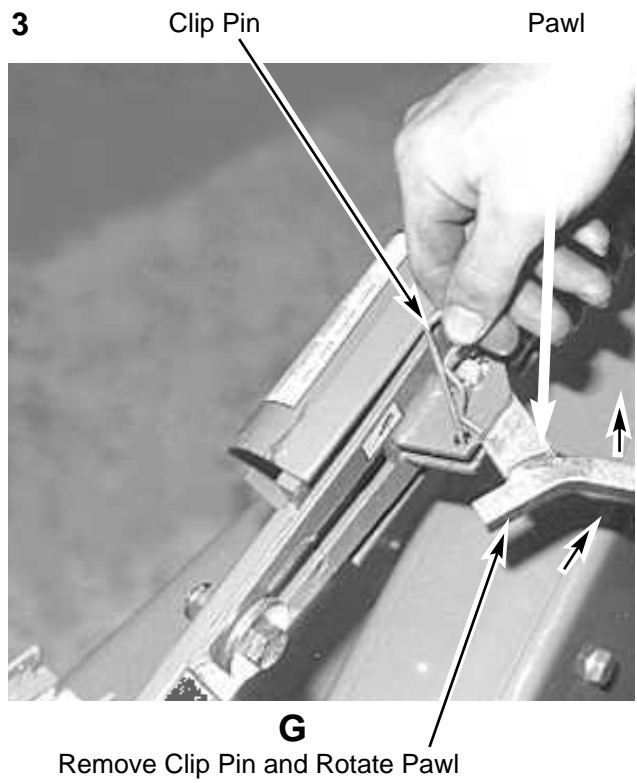
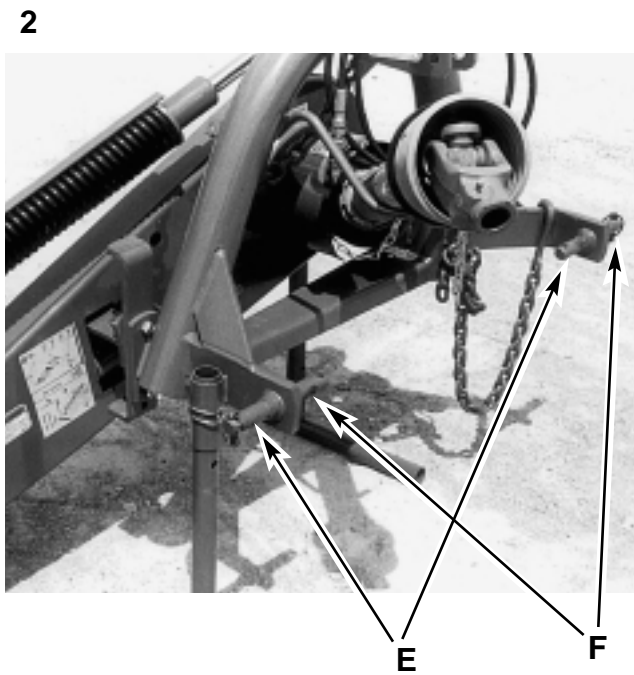
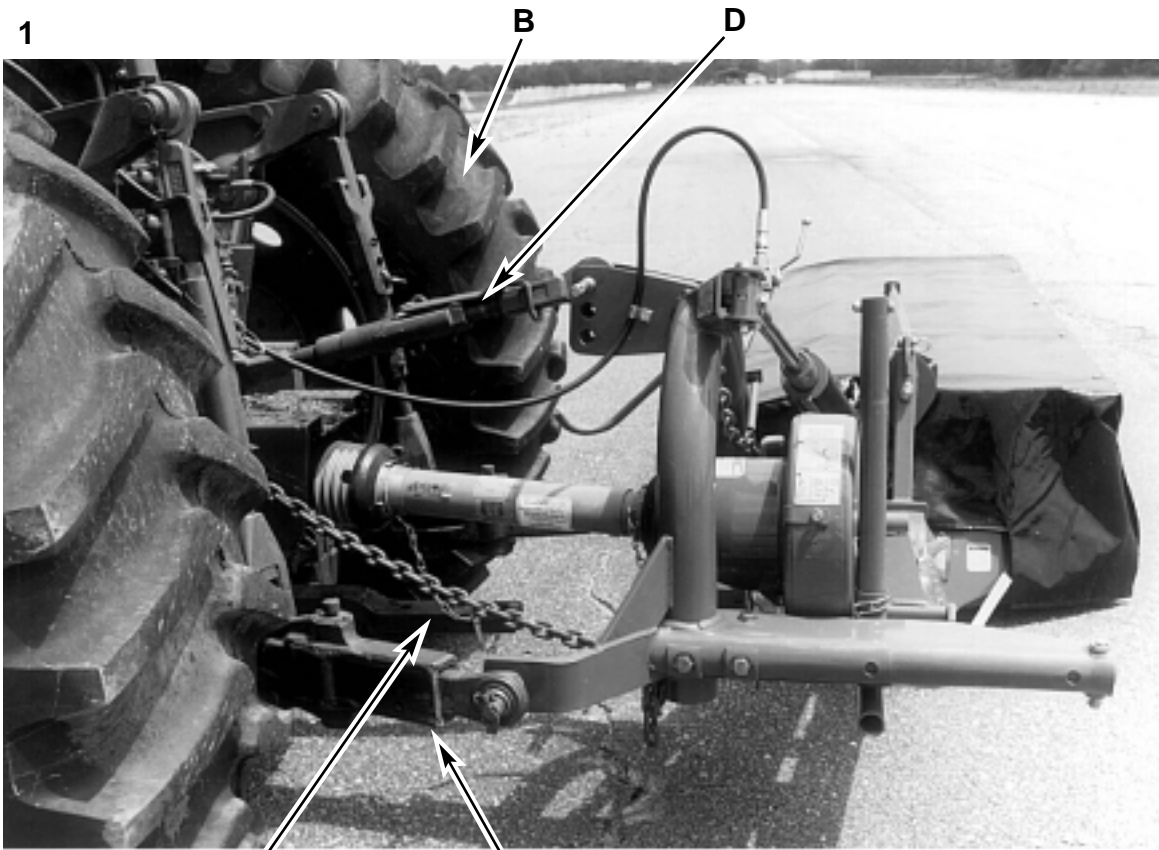

Mounting - coupling



The coupling between machine and tractor must be carried out as explained in the instructions. If the machine becomes disconnected from the tractor it could cause severe damage or death.

Fitting of the suspension

①

Check that the lift arms of the tractor are adjusted to the same height from the ground. Turn the drawbar (A) to the side or remove it. Also check the tire pressure - it is important that the right hand wheel (B) is inflated to the prescribed pressure.

If the width of the tractor is less than 2200 mm (86.6"), measured from the outer edge of the tires, hitch pins (E) must be used. Where the tractor is wider than 2200 mm (86.6"), pins (F) must be used.

NOTE: Model HM2007 is equipped with Cat. II pins to the outside and Cat. I pins to the inside. If used with a Cat. II tractor, a Cat. II bushing must be used on the Cat. I inside pin.

②

Back the tractor to the machine - fit the lift arms (C) (right hand/left hand) and the top link (D).

Raise the machine with the lift arms (C) so that it is clear of the ground and raise both of the support legs.

Tighten the stabilizer links of the tractor. Check that the arms have the same length on the right hand and left hand sides.

③

Turn the lock pawl (G) of the stabilizer in the direction indicated by arrow.

NOTE: The lock pawl can only be operated when the machine is coupled to the tractor, and the machine must be raised clear of the ground with the three-point linkage of the tractor.

1

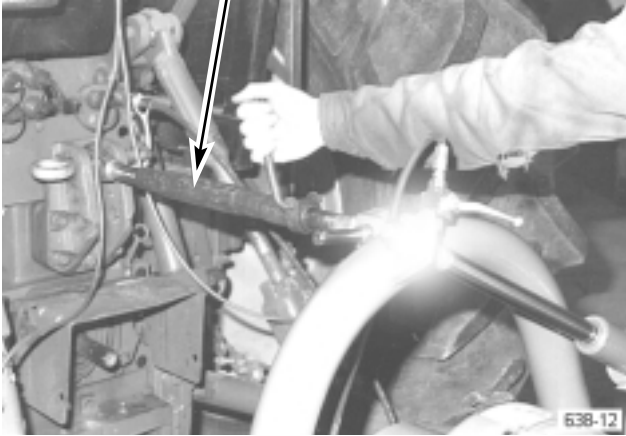

2

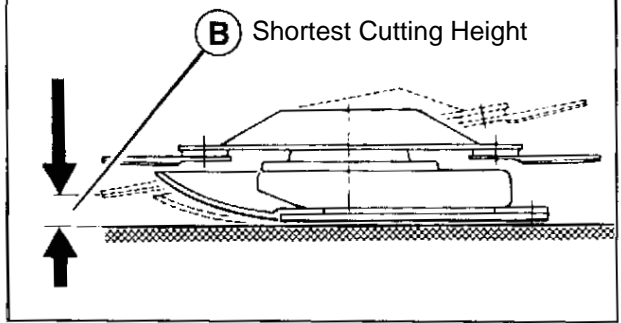

3

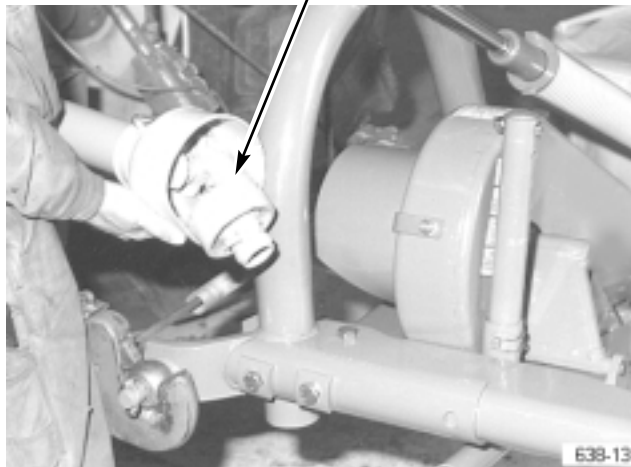

4

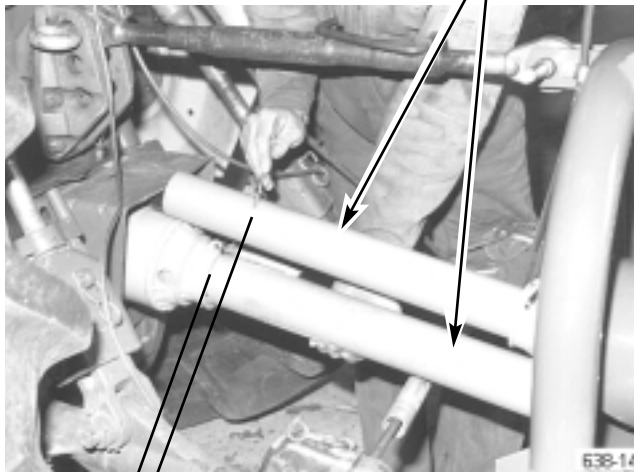

40 mm (1-1/2")

5

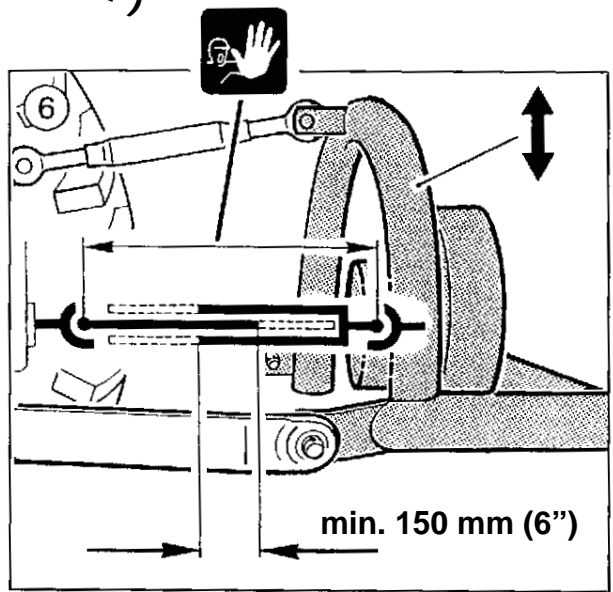
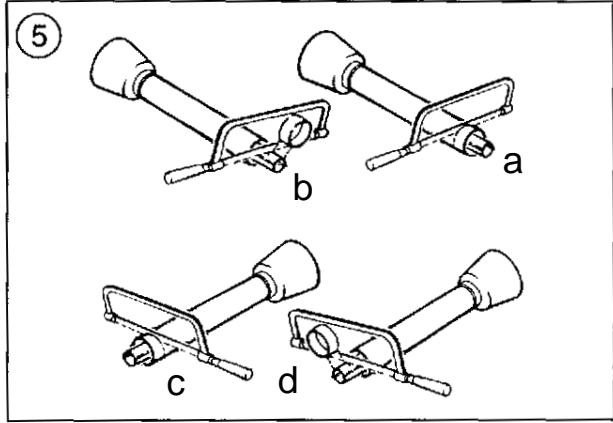

min. 150 mm (6")

① - ②

Lower the machine to the ground. Adjust the top link (A) to the minimum cutting height as shown at (B).

PTO shaft

③ - ④



Only use a tractor PTO shaft set for 540 rpm operation. It is dangerous to couple a tractor with 1000 rpm PTO output to a machine intended for 540 rpm PTO input speed.

IMPORTANT
PTO ADAPTERS SHOULD NOT BE USED WITH ANY BUSH HOG EQUIPMENT. FAILURE TO FOLLOW THESE INSTRUCTIONS WILL CAUSE DRIVELINE FAILURE AND POSSIBLE TRACTOR DAMAGE.

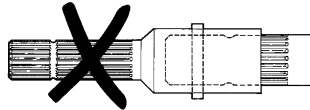

When fitting the first time, **before** checking the shaft length, the top link must be adjusted to minimum cutting height (short top link). Follow this procedure:

- Adjust the linkage so that the PTO stub shafts are level.
- Fit the two parts of the PTO shaft onto the shafts of the tractor and the machine respectively. The clutch is placed at the machine end (C).
- Place the two shaft halves together as shown at (D) and mark the shortening length (about 40 mm (1-1/2") clearance).

⑤

NOTE: Some tractor types do not require a shortening of the shaft.

Shortening of the shaft

⑥

When shortening the PTO shaft the four parts a - b - c - d must be shortened equally. After shortening, the tube ends and the shaft ends have to be filed off, cleaned of filings and lubricated.

Checking of PTO shaft length

NOTICE

Fit the shortened shaft. Carefully check that the shaft does not bottom when the linkage is raised or lowered. Also check that the sliding tubes overlap with at least 150 mm (6"), when the machine is in the working position.

This check should always be carried out when the machine is coupled to the tractor. If the tractor is replaced the above check **must** be carried out and if necessary a new adaptation of the shaft must be done.

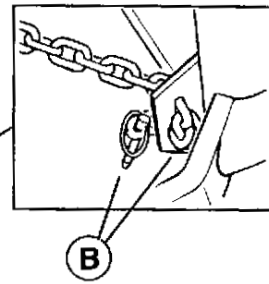
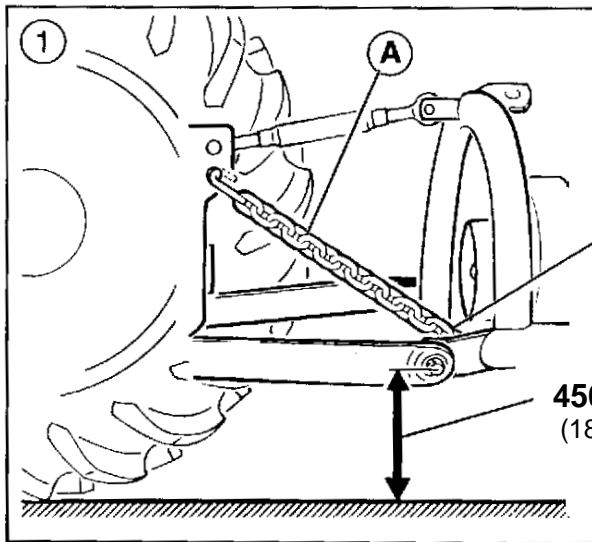

450 - 480 mm (Model HM2009 - max. 450 mm/18")
(18" - 19")

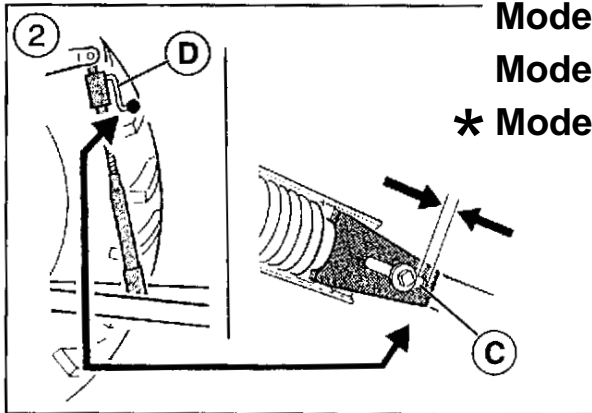

Model HM2007 - 13mm (1/2")
Model HM2008 - 11mm (7/16")
*** Model HM2009 - 8 mm (5/16")**

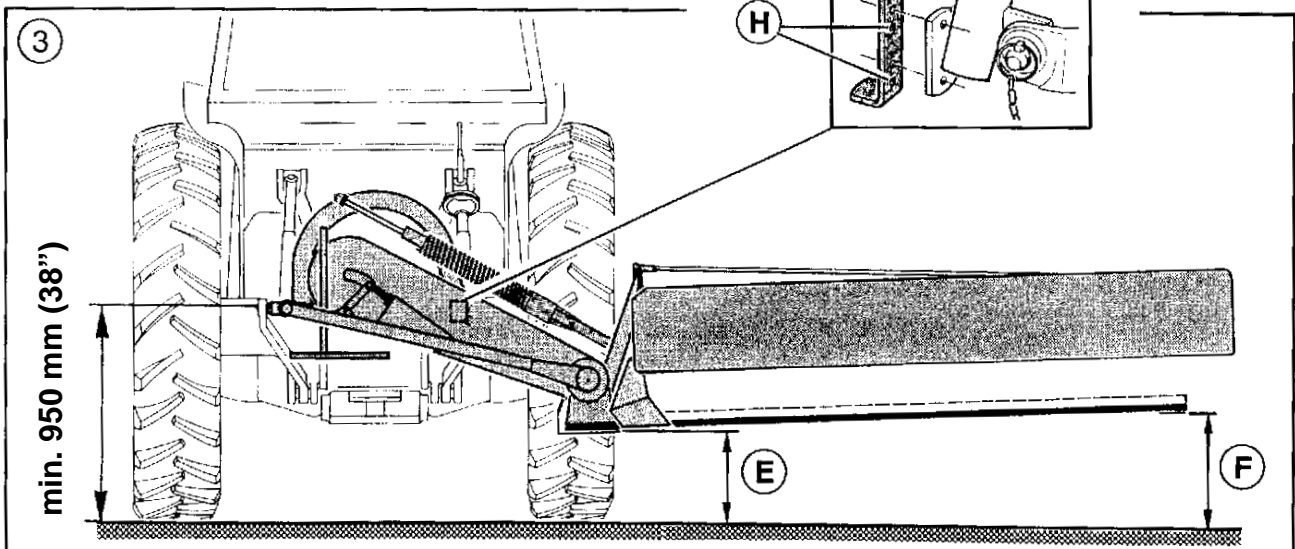

①

Height of the suspension

Important

The working height of the suspension 450 - 480 mm (18 - 19") is maintained with the chain (A). The chain is locked as shown at (B).

NOTE: If the machine is equipped with high cut skids the working height of the linkage must be 500 - 530 mm (20 - 21"). If these settings are not adhered to, it could result in excessive wear to the skids and gearbox bushings, and cause abnormal wear on the breakaway assembly.

②

Stabilizer

Check the movement area (C) of the stabilizer when the machine is in the field and lowered to the working position. If necessary adjust the right hand lift arm of the tractor (D):

If the distance (C) is too big, raise the lift arm at (D)

and oppositely if the distance is too small. **NOTE:** Adjustment of the lift arm is easier to carry out when the machine does not load it - therefore raise the machine, engage pawl, shown at the bottom of page 26, remove suspension chain and lower the machine to the ground.

* **Applies especially for model HM2009**

To assure an optimum ground following ability, it is recommended to work with a distance of 8 mm (5/16") at (C) on even land. When working on uneven land, it is recommended to use a bigger distance than 8 mm (5/16"), but note that the lifting height of the machine will then be reduced when turning in the field. Read more about lifting height in the following paragraph.

Check that the distance from the suspension to the ground does not exceed 450 mm (18"). See Fig. 1.

③

Lifting height

The lifting height of the tractor **must** be at least 950 mm (37-1/2") as shown. This lifting height corresponds to a ground clearance of approx. 300 mm (12") at (E) and 420 - 520 mm (16-1/2 - 21") at (F) depending on machine type and tractor size.

If the ground clearance is too small, check the adjustment of the stabilizer. Also check tire pressure in the right hand rear wheel of the tractor.

Lifting bracket (G) from the factory is fitted in the shown standard position. If the bracket is fitted in the holes (H) the ground clearance will be larger at (E) but smaller at (F).

NOTICE

Make sure that moveable parts are lubricated as shown on page 18. If not lubricated, lifting function will not work satisfactorily.

1 Transport Position



2

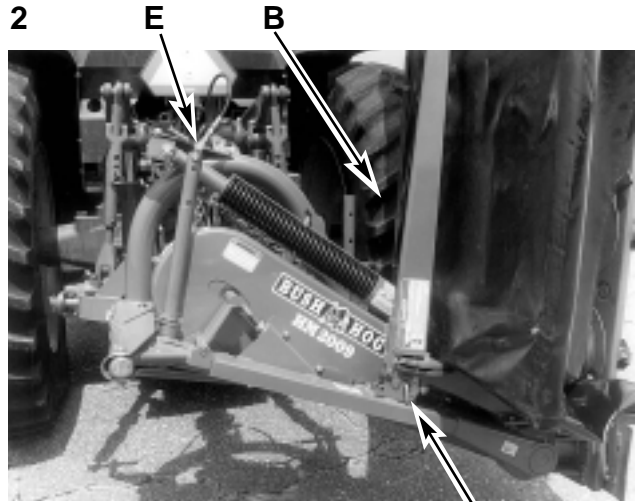

4

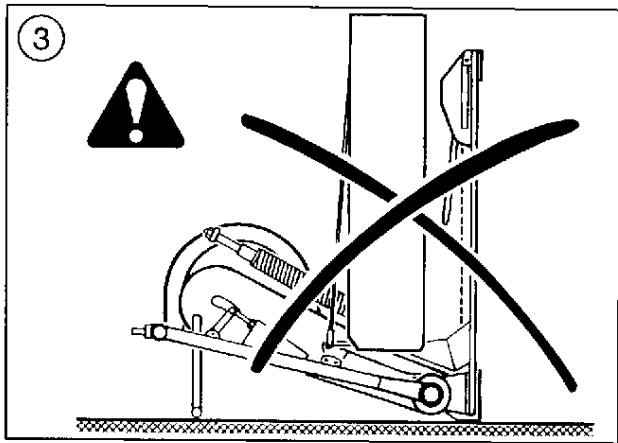
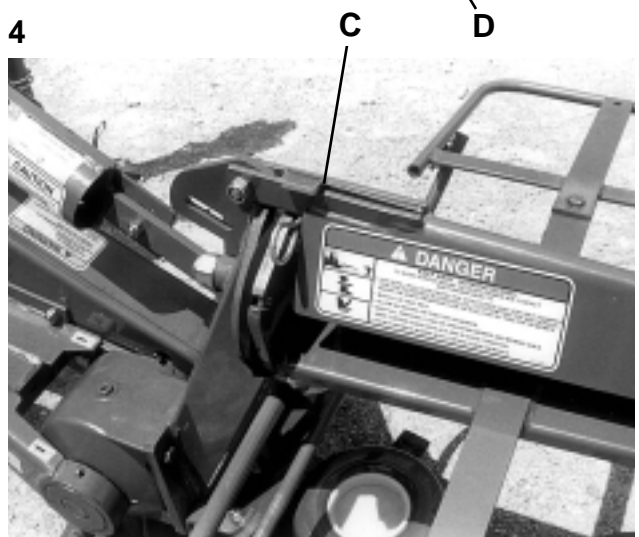

6 Un-Hitched

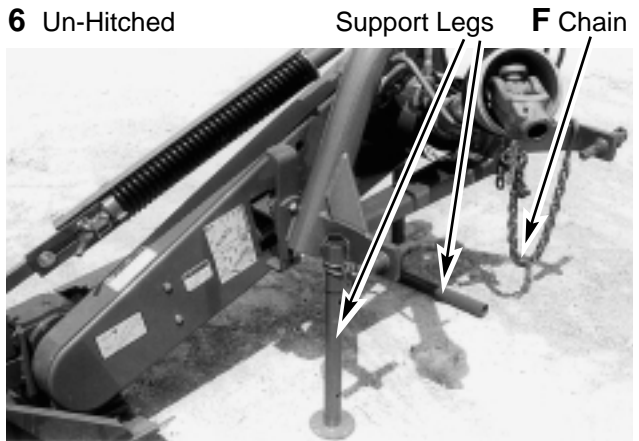

5

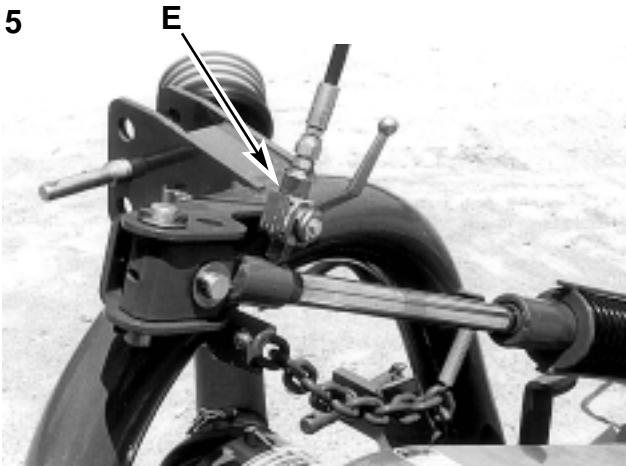

7



Transport - Unhitching

① - ②

Transport

As shown the machine can be raised to the vertical position. Raise the machine clear of the ground with the lift arms (A) of the tractor, then raise the machine to the vertical position with the hydraulic cylinder of the machine.

Be careful, check that the curtain frame of the machine can clear the rear wheel of the tractor at (B): If necessary the curtain frame can be turned forward by disengaging the pawl (C).



Be careful. Make sure that no persons are near the machine when it is being raised or lowered during transport. Lock the machine with "L" pin (D) and retaining valve (E). The "L" pin is placed in the hole on the left hand side, when the machine is lowered to working position.



Great care must be taken during transport on public roads. Reduce speed when turning and driving on uneven roads. Observe local laws for road transport.



It is the responsibility of the owner/operator to provide correct lights and reflectors on the machine, when it is transported on public roads after dark.

Unhitching

③



WARNING

The machine must never be unhitched from the tractor in the transport position. The machine will be unstable and could overturn. Always store the machine in the working position with the cutter bar on the ground.

④ - ⑦

Raise the machine with the lift arms of the tractor, remove the chain (F) and lower both of the support legs. Engage the lock pawl (G), lower the machine to the ground and unhitch the tractor.

1 A



2 B

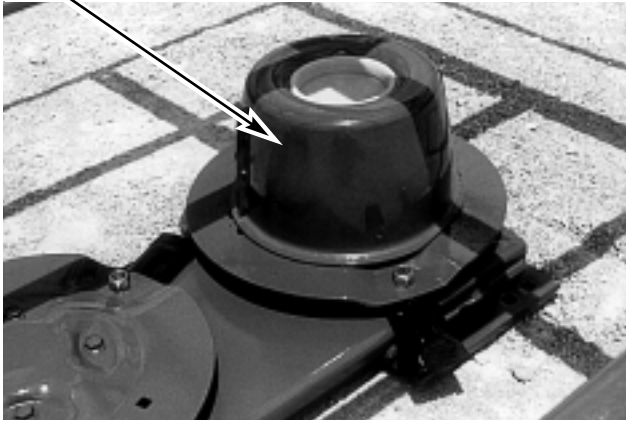

3 C

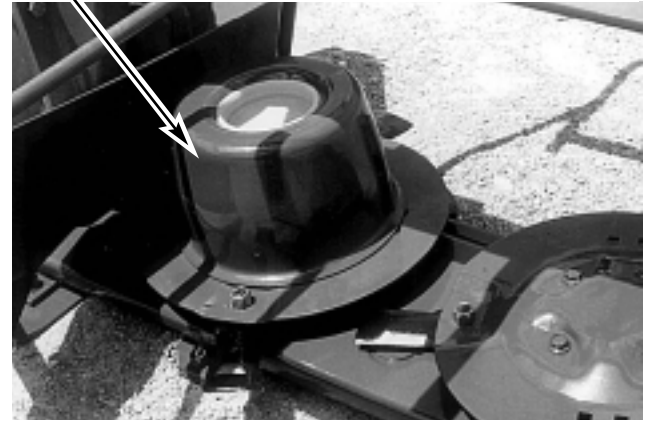

Nm
 80 ± 5



60 ft./lbs.

Nm
 95 ± 5



70 ft./lbs.

④

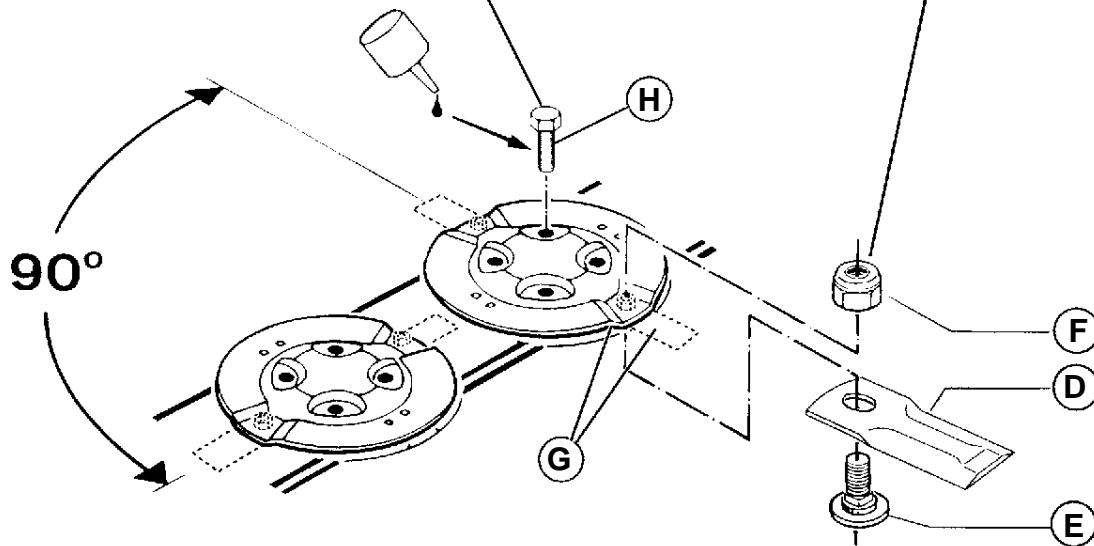

Maintenance



During all service operations concerning knives and cutting discs the tractor engine must be stopped and the hand brake activated. If the machine is in the raised position it must be firmly supported. Also refer to page 5, item 10.



Re-tighten the bolts of the cutting discs and knives on your new machine before starting and again after about 1 hour of operation. The same applies when any service work is done, for example, replacing knives.

① - ④

Knives - cutting discs

The curtain (A) of the machine can be rotated so that there is free access for inspection of cutting discs and knives. Also refer to page 26, Figure 4 - C.

NOTICE

Check daily that the bolts of the cutting discs and knives are tightened, and that cutting discs, cones and knives are undamaged. If the rotating parts are unbalanced, vibrations could occur causing damage to the cutterbar. Damage of this kind voids the warranty.

NOTICE

Keep the cones (B) and (C) on the right hand and left hand sides clean. If the cones are unbalanced, vibrations could occur causing damage to the cutterbar.

Damaged knives (D) must be replaced immediately. Twisted knives (Standard) may be turned over and used in the same location. If flat knives (Optional) are worn on one side only, they can be interchanged by using the knives from another cutting disc that rotates in the opposite direction. This will allow blades to be used on both sides. Check that bolts (E) and nuts (F) are in good order - if not, they must be replaced.

NOTE: The knives have to be in the position shown (G) to remove the bolts.



Only use original replacement parts. The cutting discs of the machine rotate at 3000 rpm - never compromise with safety.

Operate with safety - note the following:

- The cutting discs are to be fitted in pairs as shown (90° displacement of knives).
- Always use LOCTITE 242 on the bolts of the cutting discs (H).
- Torque setting as stated - make sure that splines and holders are kept clean.
- Special for **model HM2007 and model HM2009** with optional flat blade kit: The cutting disc next to the gearbox is different from the others - See page 51 for illustration.

1

D



2

E Hole In Front Belt Guard

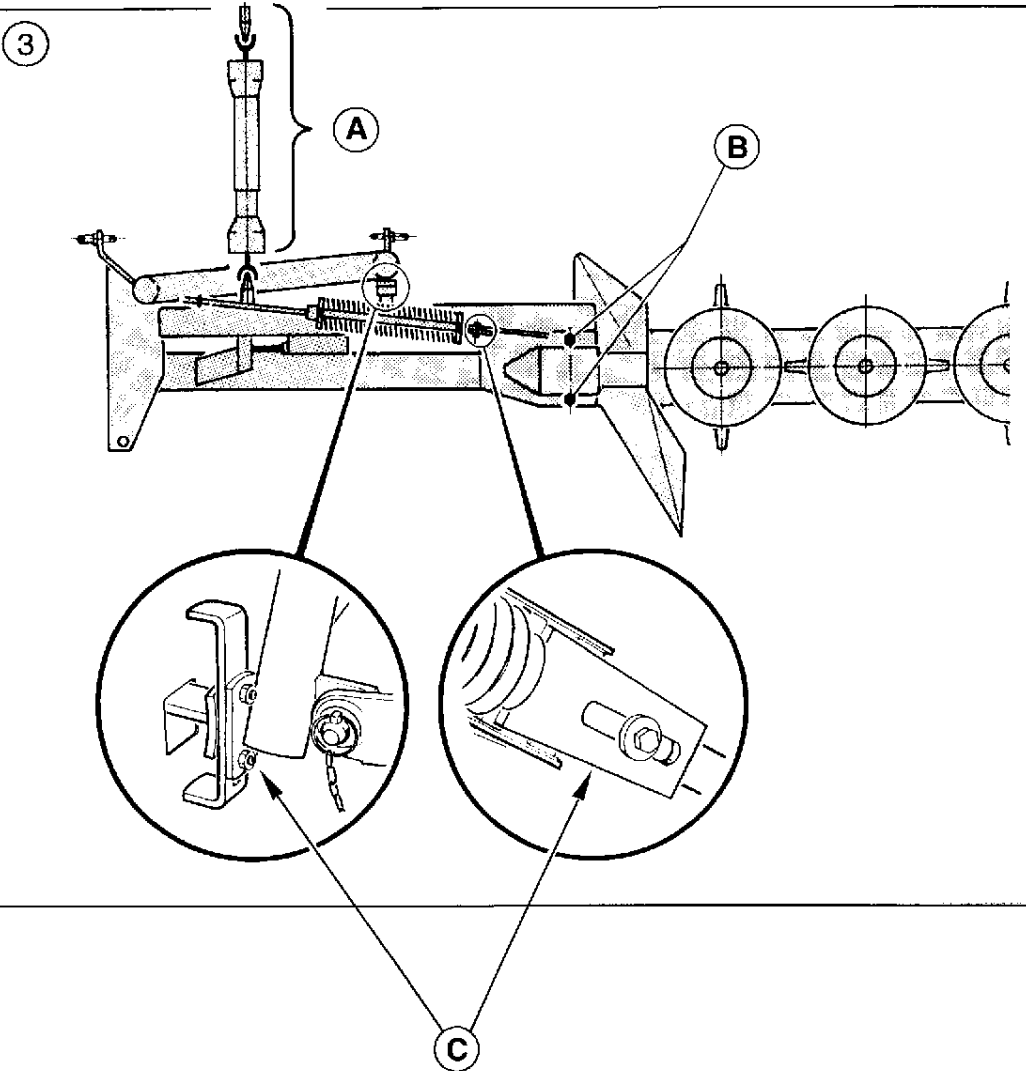

① - ②

V-belts

The spring is to be tightened so that the end of the spring is in alignment with the edge of the bracket, as shown.

Models HM2007 - HM2008 - HM2009 (D) = 0 mm

New V-belts should be re-tightened after a few hours operation. Inspection of V-belts is carried out through hole (E). The front part of the belt guard can easily be removed.

Lubrication (Lubricants, - see page 46)

Before starting to use a new machine: Check the oil level of the gearbox and the cutterbar and lubricate the machine and driveline. See pages 32 & 33 and observe all lubrication decals.

③

Lubrication generally

	Every 10th hour (daily)	Every 40th hour	Number of nipples	
* (A)	●	●	5	Driveline with overrun clutch
(B)	● ●		2	Swivel link (twice daily)
(C)	● ●			All movable parts should be lubricated with oil or grease once-twice/daily - be especially attentive to the sliding surfaces shown.

*

All universal crosses and bearings in the plastic tubes of the PTO shaft are to be lubricated every 8 - 10 hours of operation. Profile tubes should be separated, cleaned and lubricated after 40 hours use. Use lithium grease.

NOTICE

Regularly check the driveline. Any damage or lack of lubrication to the hollow shaft may cause the PTO shaft on the tractor or machine to be damaged beyond repair.

During still periods (one week or more): Wash and lubricate the machine, spray it with a thin layer of rust protecting oil - especially important at cutting discs.

The hydraulic lifting cylinder of the machine: During prolonged storage press the piston rod into the piston housing (remove the complete lifting cylinder at the connection link on the gearbox), or coat the exposed surface of piston rod with grease.

1

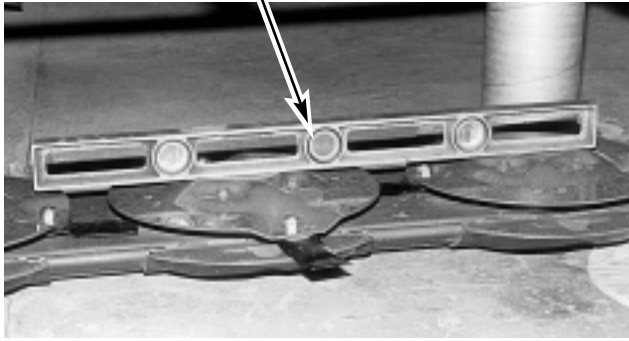

2



3

Oil Filler Plug

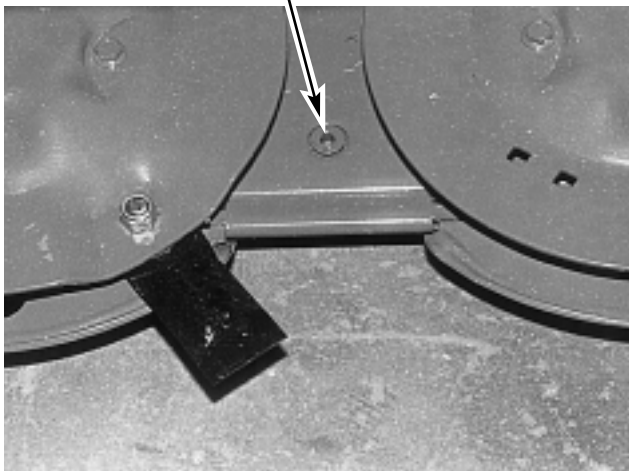

4

C

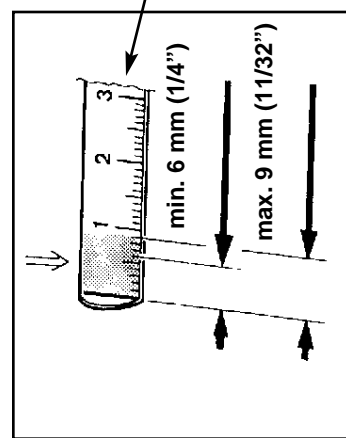

5

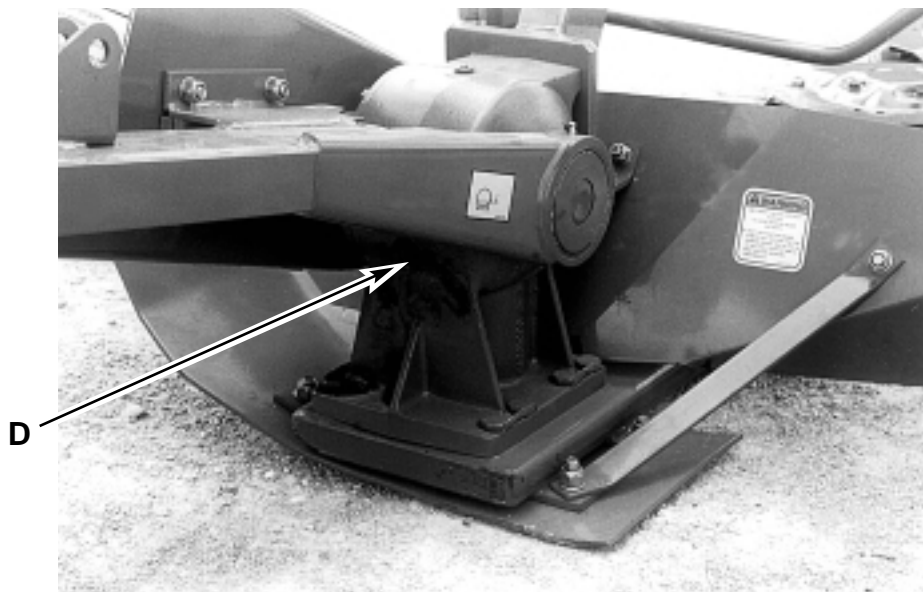

① - ④

Oil - cutterbar



The following operations must be carried out in a safe and secure way. During all work near the cutting discs of the machine the tractor engine must be stopped and the PTO shaft disconnected.

Check the oil level daily in the following way:

- Place the machine on level ground - check the position of the cutterbar with a level as shown at (A). The bar must be level in this direction. Check also that the cutterbar is level in the driving direction, shown at (B).
- Remove the oil filler plug. It is situated between the second and third disc on the left hand side of the machine. Wait for 3 minutes (if the oil is cold: wait for 15 minutes) and check the oil level using a steel tape measure as shown in (C). Amount of oil from minimum to maximum is about 1 litre (33.8 ozs.) which equals 3 mm (.11") difference in depth.

Amount of oil: **Model HM2007** = 3.5 litres (3.7 qts.) and for following oil change approx. 3.1 litres (3.3 qts.).
Model HM2008 = 4.0 litres (4.2 qts.) and for following oil change approx. 3.6 litres (3.8 qts.).
Model HM2009 = 4.5 litres (4.8 qts.) and for following oil change approx. 4.1 litres (4.3 qts.).

Change of oil: First time after about 10 hours operation and thereafter every 200 hours of operation or at least once a year. The drain plug for oil is situated on the left hand side of the cutterbar.

NOTICE

The amount of oil must never exceed the maximum stated. Otherwise the oil will be overheated and may damage the bearings in the cutterbar.

⑤

Oil - bevel gearbox

Check the oil level of the gearbox daily. The gearbox must be level.

Oil level : Plug (D).

Amount of oil: 0.3 litres (10 ozs.).

Change of oil : Change the oil after about 10 hours of operation and thereafter at least once a season. The oil can be drained through level plug when the cutterbar is in vertical position.

NOTICE

This transmission rotates at high speed - about 3000 rpm. Therefore, it is important to use the correct type and amount of oil. Otherwise overheating will occur and damage the transmission. Damage of this kind is excluded from Bush Hog warranty.

At the back of this manual, page 46 "lubricants" are shown. Only use oil types marked (H) for transmission with such high working speeds.

1 Swath Roller

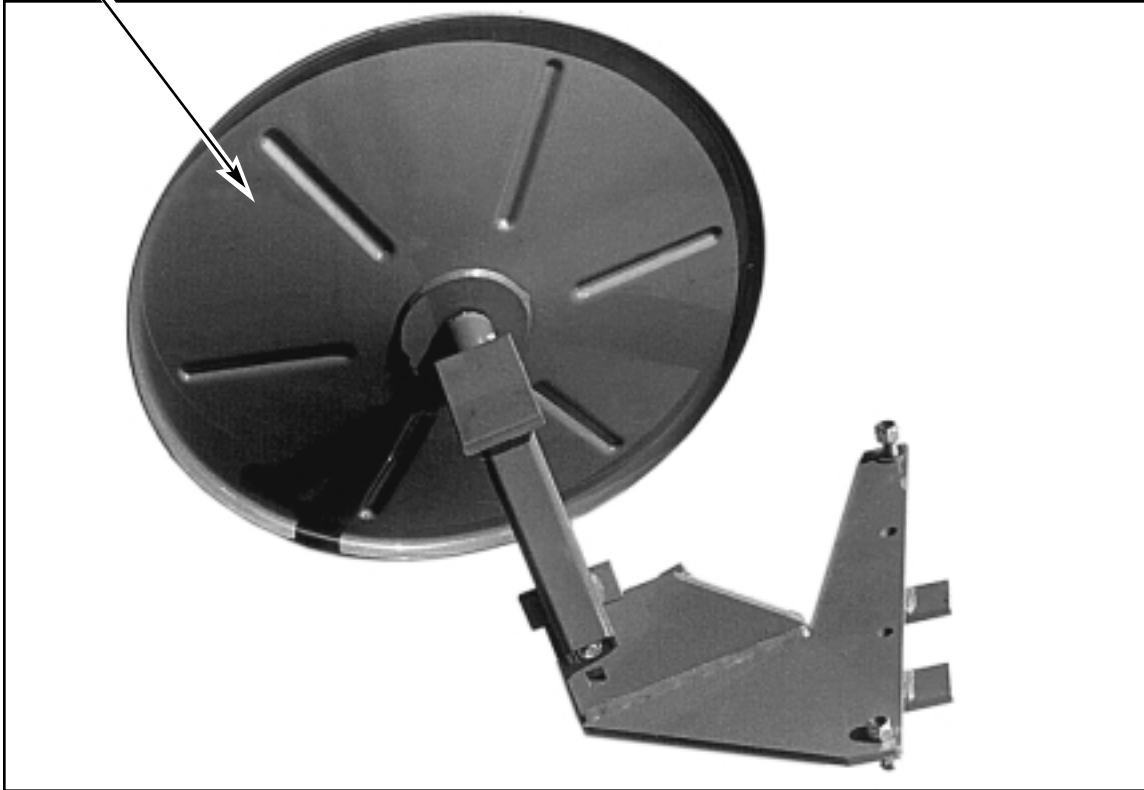

2

Swath Board

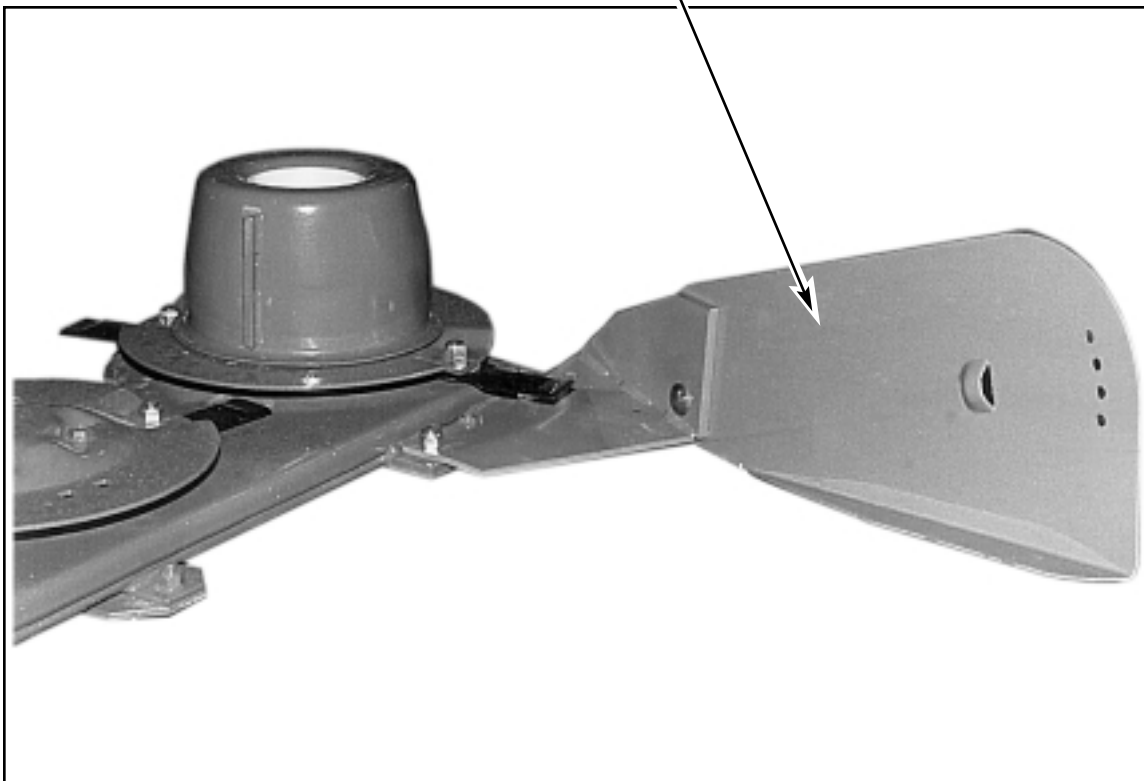

Optional equipment

①

Right-hand & Left-hand swath rollers

The machine can be equipped with swath rollers as shown.

②

Right-hand & Left-hand swath boards

The machine can be equipped with swath boards as shown.

1 Hillside Kit As Seen From Below

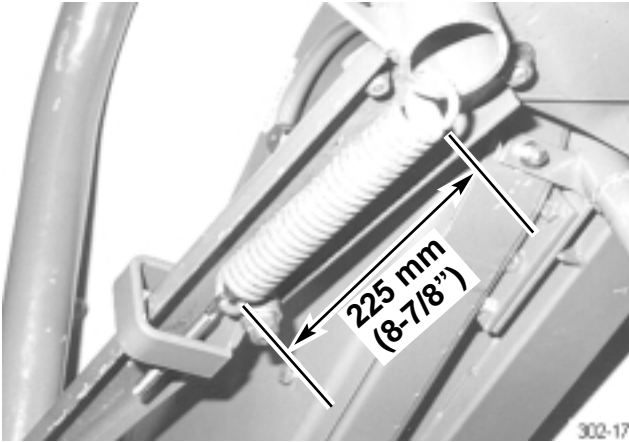

2

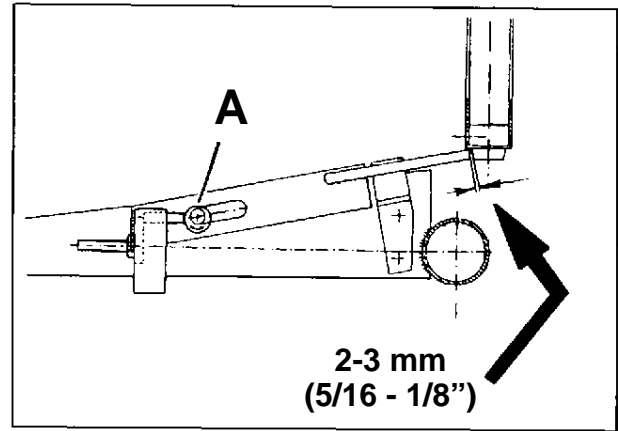

3 Inside High Skid

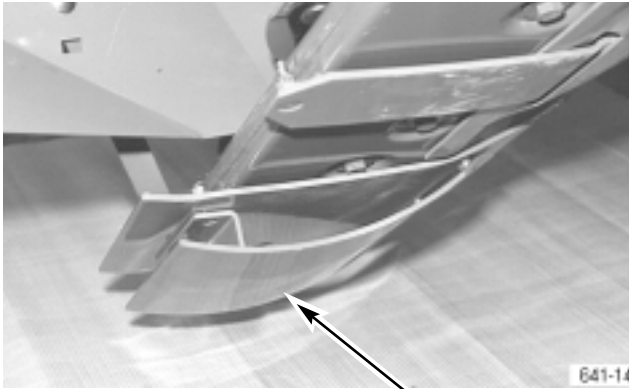

B

4 Outside High Skid

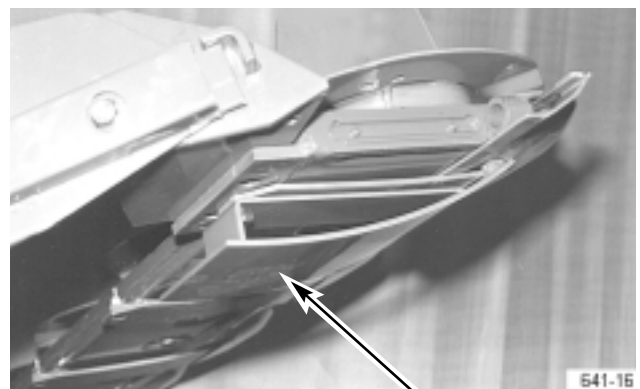

C

① - ②

Optional hillside kit

The spring lock keeps the machine in position in proportion to the tractor. If the machine meets a firm obstacle, the lock is released and the machine swings to the rear. Refer to the Hillside Kit Instructions for more information.

The spring lock must be adjusted. Screw (A) is eccentric. Tighten the bolt to minimum 225 mm (8-7/8") Refer to Hillside Kit Instructions..

③ - ④

Optional high skid

The skids of the machine are fixed and cannot be height-adjusted. If the machine operates in fields with many stones, molehills, etc., high skids (B) and (C) are recommended. The cutting height is then increased to about 60 mm (2 -3/8"). Also refer to NOTE on page 25 for height adjustment.

Fitting: Set of skids, 2 pcs., are to be placed in the right hand and left hand side of the machine. They must be fitted below the fixed skids as shown in photos 3 and 4.

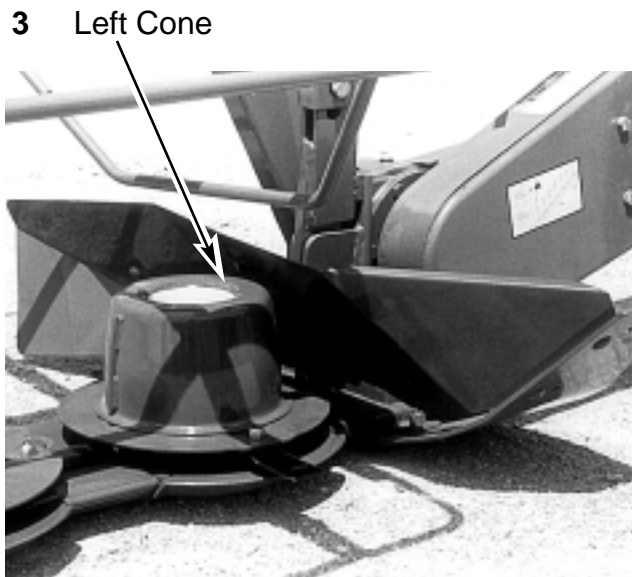
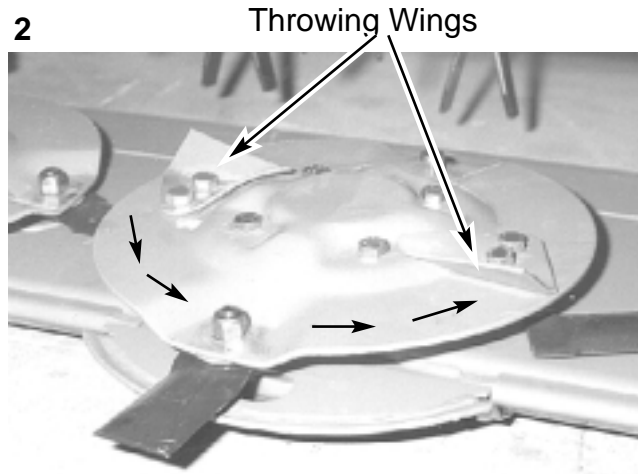
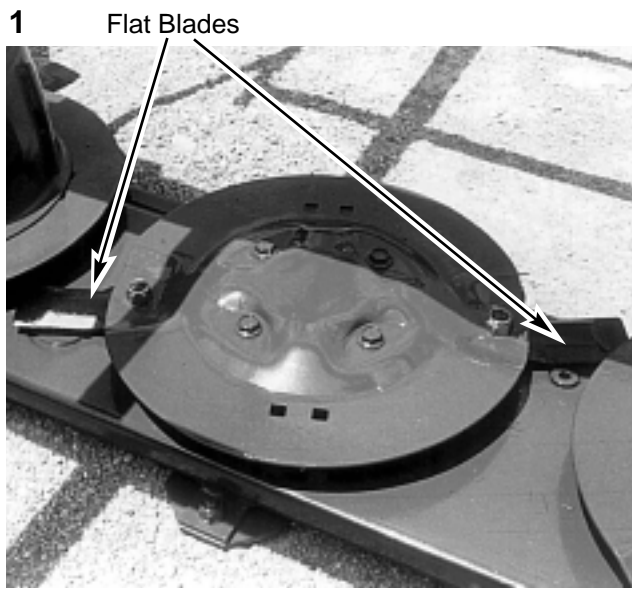

①

Special flat knives

Special flat knives are recommended for rocky conditions.

Special flat knives may be used on all models. However, for Models HM 2007 and HM2009, the number one cutting disc, next to the gearbox, must also be changed. The special flat knives and number one disc are available from your dealer.

②

Throwing wings

Throwing wings are recommended for very light grass conditions.

③

Left cone

The cone (B) at gearbox is standard equipment for model HM2008 and model HM2009. It is available for model HM2007 as extra equipment. The cone is recommended for mowing of long, wilted grass.

1

A

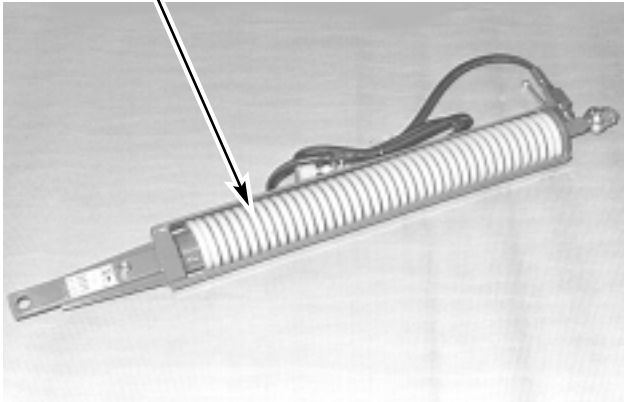

641-18

2

B

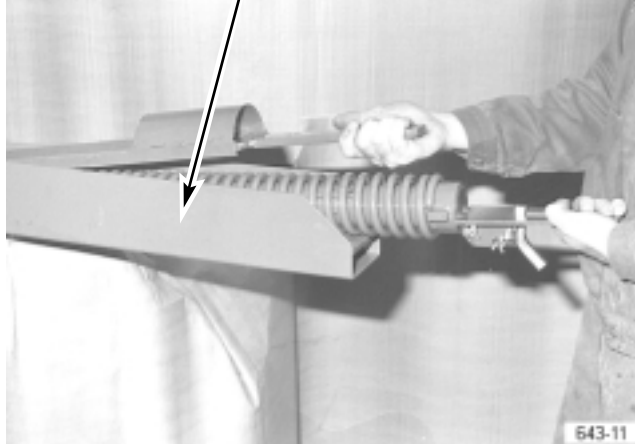

643-11

3

C

D

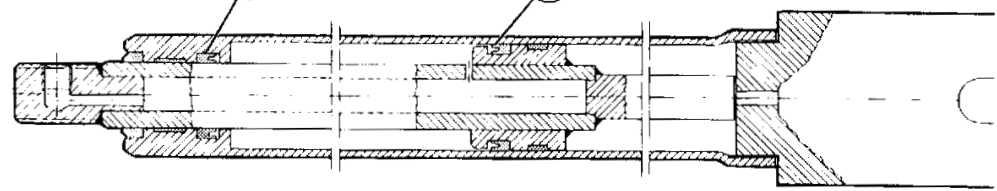

4

1.4 - 2.8 mm
(.055 - .110")

500 mm
(19-5/8")

0 - .05mm
(0 - .002")

E

F

G

H

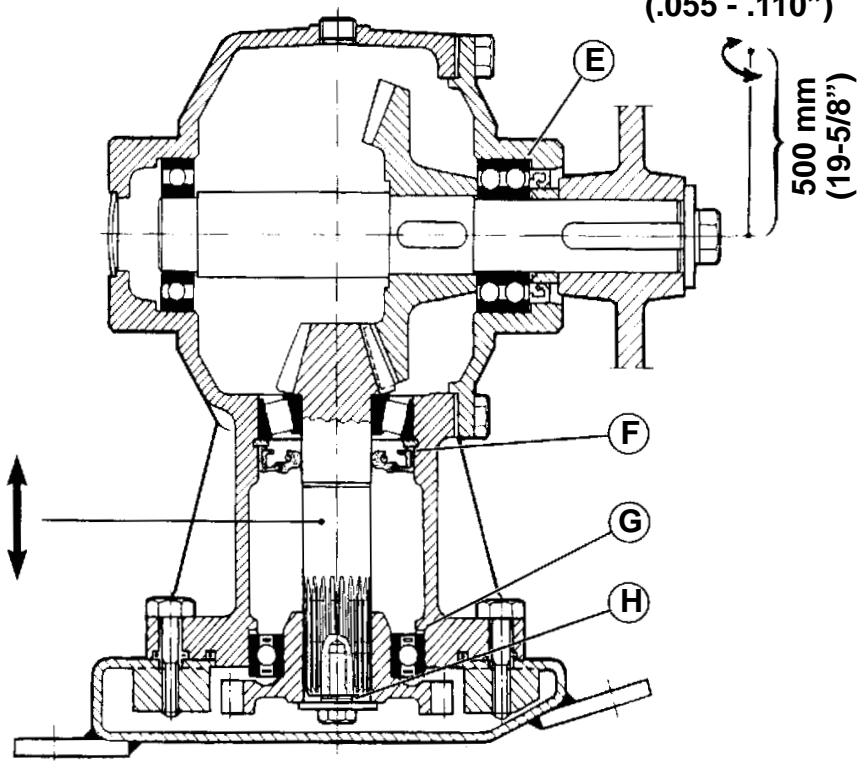

Directions for repair



Repair must only be carried out by competent persons with experience of using workshop equipment and trained in the repair of agricultural machinery in a safe and responsible manner.

① - ②

Stabilizer



Be careful. Remove stabilizer from machine for disassembly. Never disassemble the stabilizer (A) without use of special tools (B). The spring is tightened to 800 - 1000 kg (1764 - 2205 lbs.). Special tools (B) are available.

③

Hydraulic lifting cylinder

New set of seals must be fitted as shown. Sealing rings (C) and (D) must be positioned as shown.

④

Bevel gearbox

NOTICE

Repair of the gearbox must only be carried out by competent persons with thorough knowledge of such work. Tooth clearance must be within the stated values.

NOTE THE FOLLOWING:

Checking of tooth clearance (mesh) can only be measured on a clean and oil free gearwheel. Refer to gearbox repair manual for all gearbox repairs.

Use a 500 mm (19-5/8") long torque bar attached to the pinion shaft bolt when checking the tooth clearance. The stated values from 1.4 to 2.8 mm are valid with a 500 mm torque bar. Adjust tooth clearance with shims at (E). Adjust the slack of the roller bearing at the bevel pinion wheel by means of the washers (G) and (H).

Sealing ring (F) must be turned as shown.

Important, when fitting the gear to the machine:

Use tab to lock the 8 bolts retaining the gear to the cutterbar.

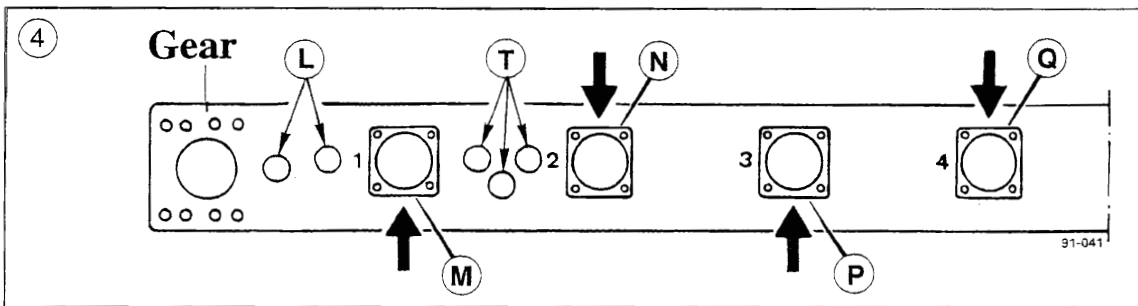
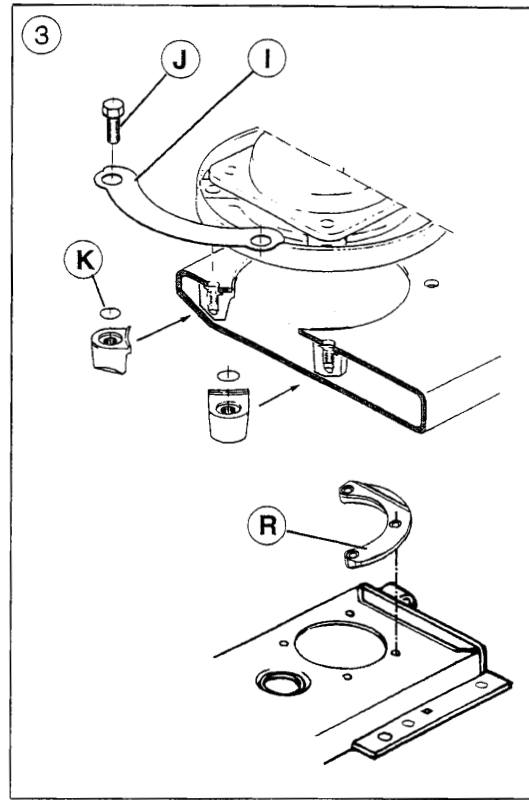
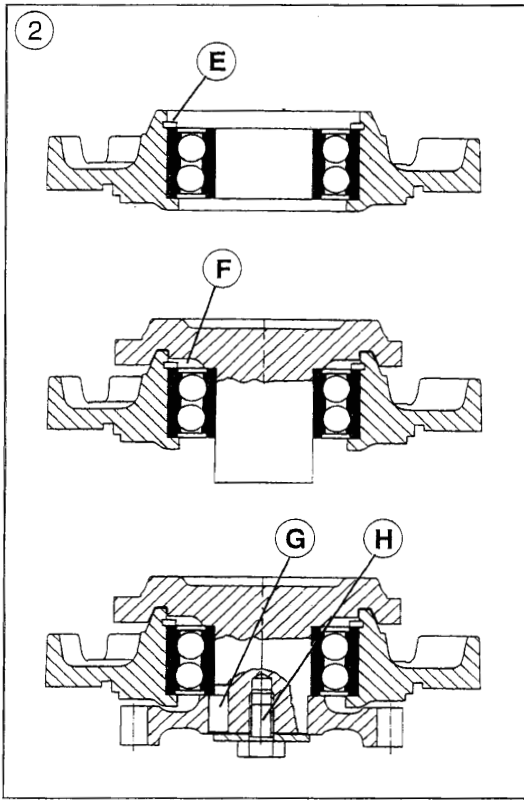
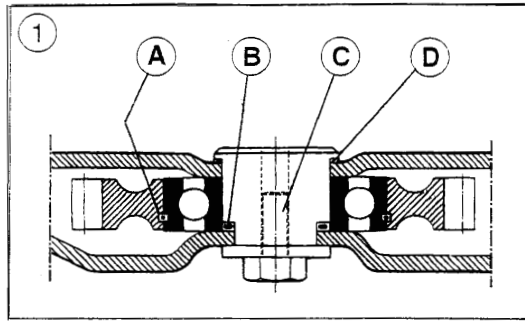

Cutterbar

NOTICE

Be particularly attentive when checking or repairing the cutterbar - it rotates at 3000 rpm. Take care that worn bearings and gear wheels must be replaced in time. Otherwise a single damaged bearing might cause damage to the whole cutterbar. Use LOCTITE when stated - hardening time approx. 15 minutes.

Intermediate gear (illustration 1)

Inspection of intermediate gear can be carried out through the collar bearings holes. Intermediate gears can only be removed through the opening in the right hand side of the cutterbar, but gear at (L) and gear at (T) (only model HM2007 and model HM2009) can be removed through collar bearing hole. These gears are smaller than the others. Note the following when replacing the bearings:

- When pressing out the bearing, sealing ring (A) is pressed into pieces. Use a new sealing ring when fitting a new bearing.
- Check that gasket (B) and (D) have not been damaged. The thread surfaces on bolt (C) must be locked with LOCKTITE type 242. The torque setting is $Nm = 90$ (66.4 ft./lbs.).

Collar bearings (illustration 2)

Press the bearing into the bearing housing. Mount the locking (E). Fill the hollow space (F) of the flange, shown at (F), with grease of good quality. NOTE: A tool kit is available for this procedure.

Use a support on the inner race of the bearing when the flange axle is pressed into the bearing. Place the key (G) in the gear wheel hub, carefully press the parts together, and be sure that the key slides correctly into the keyway of the shaft.

Apply a little LOCTITE 242 to the retaining bolt (H) and tighten with a torque wrench to $Nm = 50$ (37 Ft. Lbs.).

Fixing of collar bearing (illustration 3)

Lock the bolts (J) by means of tabs (I). Torque moment is $90 \pm 3 Nm$ ($66 \pm 2 Ft. Lbs.$). Check that the gaskets (K) in the loose threaded pins are not damaged. Use the threaded rod (R) for the collar bearing in the righthand side.

Synchronizing (illustration 4)

Before fitting the collar bearing take care that the collar bearing flanges are in the correct positions in relation to each other. This is especially important between the 1st and 2nd disc on the model HM2007 and model HM2009, as the discs rotate the same way. This synchronizing can be achieved in the following way:

- Fit the 1st collar bearing - turn the flange so that the marked edge (M) faces to the rear.
- Fit the 2nd collar bearing. Turn the flange so that the marked edge (N) faces forward in the drive direction before lowering the gear wheel into mesh. Continue with this procedure when fitting the other collar bearings (P), (Q), etc.

Problem/Fault Analysis and Corrections

Problem	Possible Cause	Correction
Cutterbar swinging to the rear or cannot follow the ground.	<p>Stabilizer lock engaged.</p> <p>Stabilizer not correctly adjusted.</p> <p>Stabilizer fitted in wrong hole on the tilting bracket or wrong tilting bracket in use.</p> <p>Wrong stabilizer spring fitted.</p> <p>Very hilly ground.</p>	<p>Disengage stabilizer lock.</p> <p>Adjust right hand lifting arm tractor correctly.</p> <p>Check correct fitting.</p> <p>Model HM2007 and model HM2008 thread - diameter = 13mm (.51") . Color = green.</p> <p>Model HM2009 thread - diameter = 15 mm (.59"). Color = black.</p> <p>The machine can be equipped with a spring lock.</p>
Adjustment of spring is changing.	The lifting arms of the tractor are lowering slowly (leaky valve).	Fit chain so that the linkage of the machine is kept in the correct position.
Machine hangs too low when it is raised with the three-point linkage of the tractor.	Working height of linkage wrong and or wrongly adjusted stabilizer.	Check correct fitting.
Swath is not satisfactory.	<p>Swath roller or swath board.</p> <p>Model HM2007:</p> <p>These machines have no cone on the left hand side.</p>	<p>Change, if necessary, from swath roller to swath board or contrary.</p> <p>Fit cone on the left hand side.</p>
Uneven stubble.	<p>Stabilizer not correctly adjusted.</p> <p>Forward speed too slow.</p> <p>PTO rpm of the tractor is too low.</p> <p>Cutting knives too blunt or some knives missing.</p> <p>V-belts too loose.</p>	<p>Adjust right hand lifting arm of the tractor correctly.</p> <p>Increase forward speed.</p> <p>Increase PTO speed to max. do not exceed 575 rpm.</p> <p>Turn cutting knives or replace them.</p> <p>Tighten V-belts.</p>
*Stripes in the stubble.	<p>Inclination of cutterbar not correct.</p> <p>Cutterbar fitted with high cut skid.</p> <p>Packing of material on the cutting discs.</p> <p>Forward speed too slow.</p>	<p>Adjust the top link so that the inclination of the machine is changed.</p> <p>Remove high cut skid.</p> <p>Try to fit throwing wings on one or several cutting discs.</p> <p>Increase forward speed.</p>
Cutterbar overheating.	<p>Too much oil in the bar.</p> <p>Wrong type of oil used.</p>	<p>Check the oil level.</p> <p>Change the oil to correct type.</p>
PTO knocking.	The inclination of the machine is wrong (low stubble height).	Adjust the machine vertically.

*Strip problems can occur especially in short, heavy spring crops harvested under unfavorable weather conditions. At first always ensure that the knives of the cutting discs are kept sharp. Try to change the inclination of the machine a little (forwards or backwards). Be sure that the PTO shaft does not bottom, when the length of the top link is changed.

Winter storage

When the season is finished, preparation for winter storage should take place immediately. Start by thoroughly cleaning the machine - then grease the machine thoroughly so that any remaining water is pressed out of the bearings. Change the oil in cutterbar and gearbox and let the machine rotate for a few minutes.

Go over the machine for wear and other defects - make a note of the necessary parts required for the next season and place your order for spare parts.



Observe the safety instructions of the machine. The winter storage operations must only be carried out by competent persons with experience of working with agricultural machinery in a secure and responsible way.

Pre-winter storage procedure:

- Check all points mentioned in the MAINTENANCE part shown on page 29. Especially pay attention to the cones of the cutterbar.
- Check the cutting discs for wear. The central cutting discs can be interchanged, so that they get the opposite direction of rotation.
- Also check the gear wheel of the cutterbar for wear by removing one collar bearing in the left hand side (maximum load). Also check bearing back-lash. Repair of the cutterbar - see page 43.
- Check V-belt transmission for wear.
- Always make sure that the safety equipment of the machine is not worn or damaged, e.g. the tube protection of the PTO shafts, guards at the rotating parts and the tarpaulin-guard of the machine.
- Press the hydraulic piston into the cylinder housing. Dismantle the linkage pins if necessary.
- Sprinkle a thin coat of rust preventing oil all over the machine. This is especially important on all parts polished with use. Store the machine in an aerated house.

Conversion Chart

BASIC UNIT:	SI-METRIC UNIT:	CONVERSION NUMBER:
LENGTH	1 m =	39,4 in = 3,3 ft = 1,1 yd = 0,00062 miles (US)
AREA	1 m ² =	1,2 yd ² = 10,8 ft ² = 0,00025 acre = 0,0001 ha
VOLUME	1 dm ³ (1 l) =	61 in = 0,035 ft = 0,22 gallons (Imp) = 0,26 gallons (US) = 1,76 pints
SPEED	1 m/s =	3,6 km/h = 2,24 mile/h = 3,28 ft/s = 1,94 knob
FORCE	1 N =	0,10 kp = 0,22 lbf
POWER	1 kW =	1,36 hk = 1,34 hp = 102 kpm/s = 860 kcal/h = 737 ft lbsf/ s
MASS (Weight)	1 kg =	2,2 lbs = 0,0197 cwt. = 0,07 slug = 35 oz
MOMENT of Force	1 Nm =	0,102 kpm = 8,8 lbf in = 0,74 lbf ft
PRESSURE	1 kPa =	0,01 atm (kp/cm ²) = 0,14 lbf/in ² = 7,5 torr
Revolutions	min ⁻¹ =	rpm

Lubricants:

Supplier	Lubricant	Grease Nipples
BP.	Energear Hypo 80 W, GL5 Rating	Energear L 21 M
CASTROL	Castrol EP80 W, GL5 Rating Multitrax 75 W/90, GL5 Rating	Castrol MS 3 Castrol Molymax
MOBIL OIL	Mobilube HD 80 W, GL5 Rating	Mobilgrease Special
SHELL	Spirax GX 80 W, GL5 Rating	Retinax MS
TEXACO.	Geartex EP-A 80 W, GL5 Rating Multigear S 75W-90, GL5 Rating	Multifak T EP 2 Molytex EP 2

*Torque Value:

Torque moment for bolts normal metric thread quality 8.8 black and/or galvanized and ungreased when tightened on a smooth surface or a plain washer.									
Thread Diameter mm	5	6	8	10	12	14	16	20	22
Nm $\begin{matrix} +10\% \\ -0 \end{matrix}$	6	10	26	52	90	144	225	436	594

*Please check Operator's Manual for special torque settings, i.e., for bolts in knives, bearings, etc., as this table only refers to bolts without a torque setting in the Operator's Manual.

Models HM2007, HM2008 & HM2009

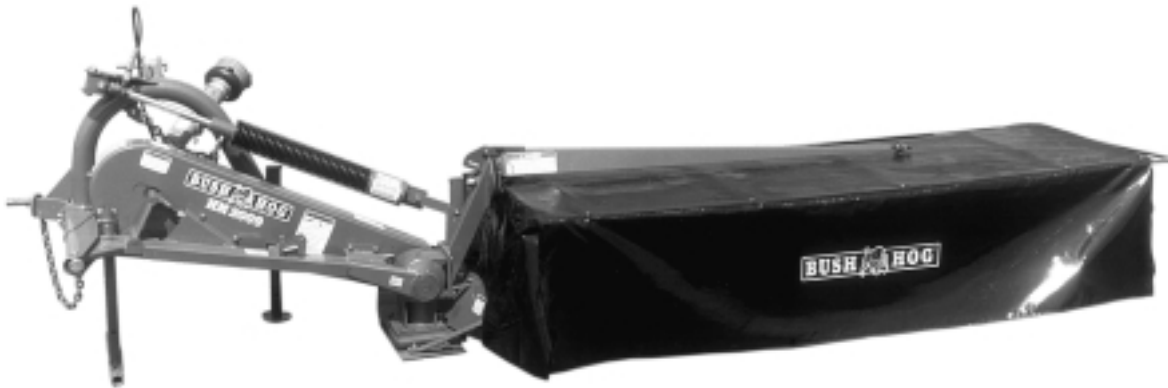

ASSEMBLY INSTRUCTIONS

NOTICE

For transport from the factory to the user the machine has been dismantled into main components. The following assembly instructions will tell you how to reassemble the machine. Please follow the assembly order shown and use the types and sizes of bolts shown for assembly of the parts. Look for the following symbols:

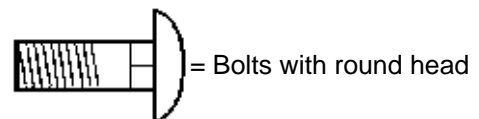
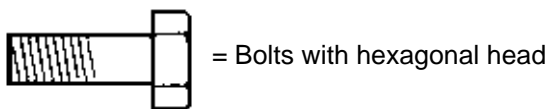

NOTE: If the Hillside Kit will be used, refer to separate instructions and install after Step 3 on following page.



In general, assembly of machines should only be carried out by skilled service staff having knowledge of safe use of workshop tools. The assembly of some machine types also requires knowledge of the tractor hydraulics or hydraulic pump station.

Figure 1 HM2007 In Shipping Crate

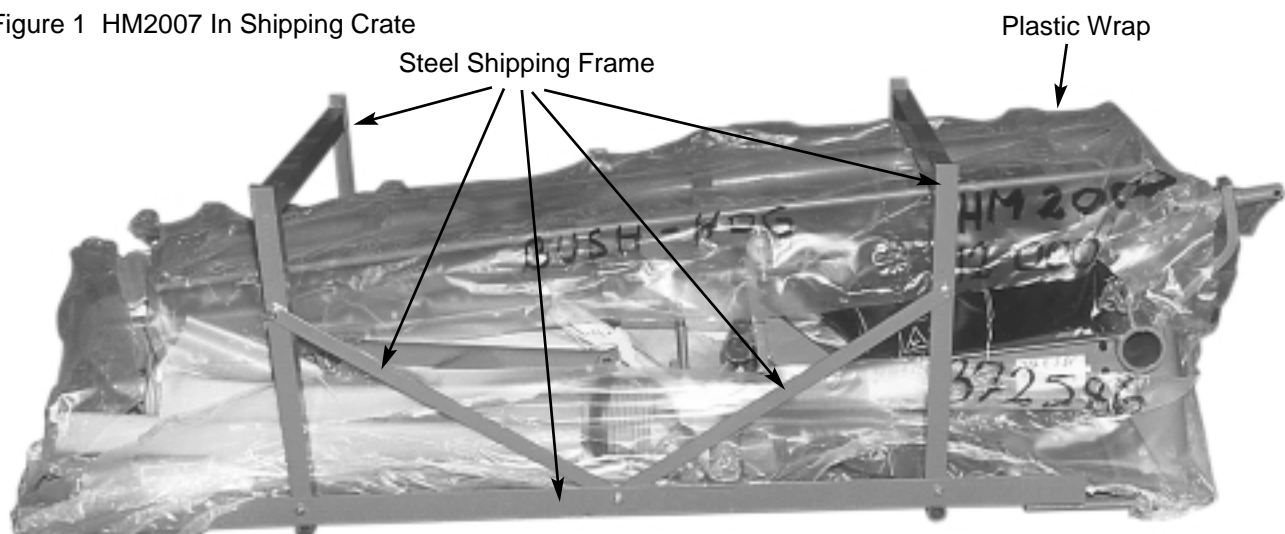
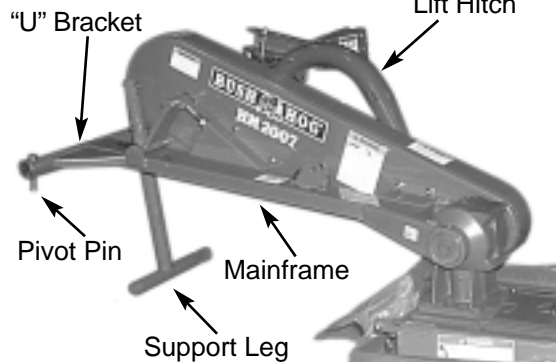

Figure 2



Mainframe assembly unfolded from cutter bar. Three point lift hitch and parking stand have been assembled to mainframe. Cutter bar remains in bottom section of steel shipping frame.

Cutter Bar

ASSEMBLY

1. Unbolt steel shipping frame. (Figure 1) These frame members will be discarded. Remove plastic wrapping and cut wiring that holds loose pieces together.

2. Arrange loose parts on floor for easy identification. Lay out fasteners in groups according to size.

3. Unfold mainframe assembly from over cutter bar. Install "T" shaped support leg up through mainframe and pin in place to support the mainframe. Replace nut and bolt in top of support leg. (Figure 2)

4. Remove threaded block from inside of "U" bracket. Slide the three point lift frame over the "U" bracket and assemble together using the threaded

block on the inside and the two square washers on the outside. Fasten with two M16 x 2 - 40 bolts. Use two M16 x 2 - 35 bolts, flatwashers and locknuts through the vertical holes. (Figure 3)

5. Remove pivot pin from end of mainframe tube. Insure that the threaded plug is screwed in flush with the end of the tube. Fasten the "U" bracket to the mainframe tube using the pin and flatwasher previously removed. Grease the sliding contact points. (Figure 3)

6. Insert and pin the front support leg into position to further stabilize the mainframe. (Figure 4)

Figure 3 Tighten Bolts "A" Before Bolts "B"

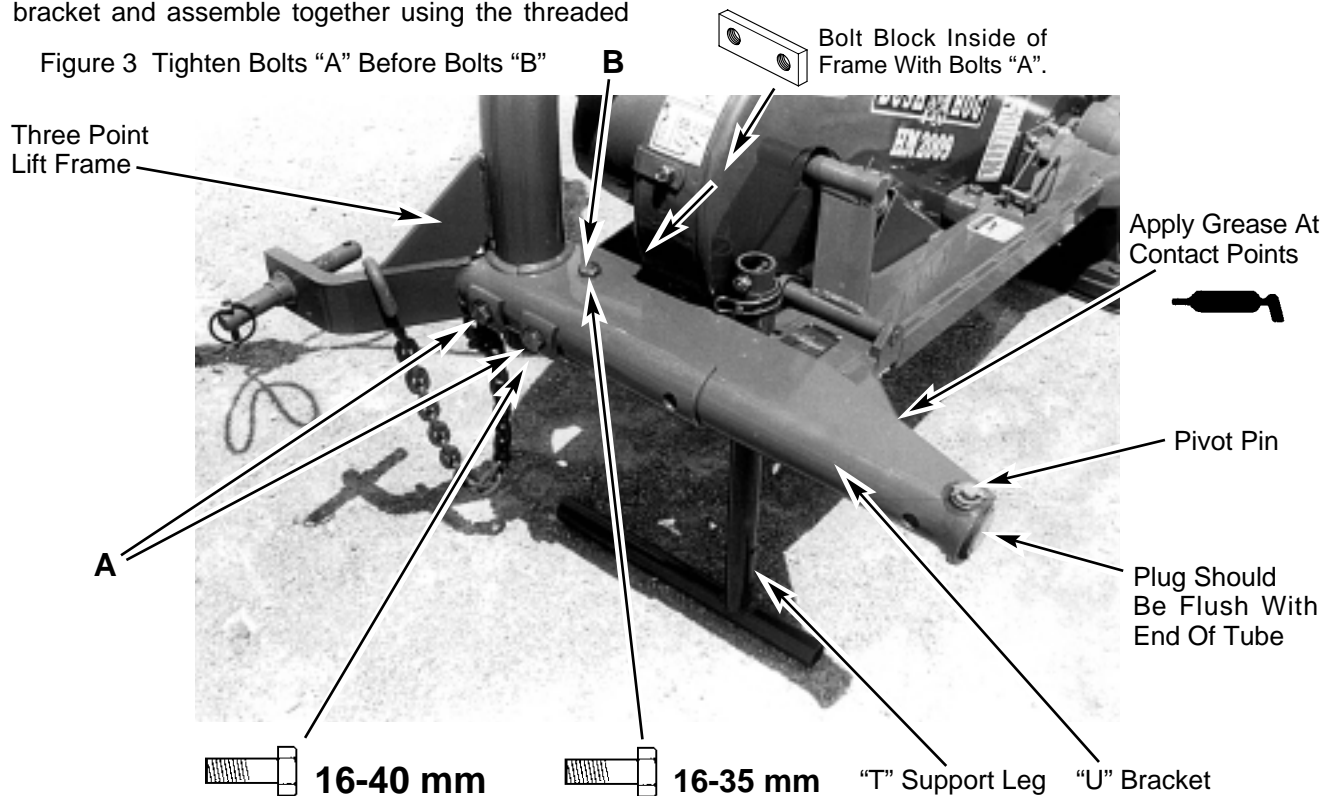
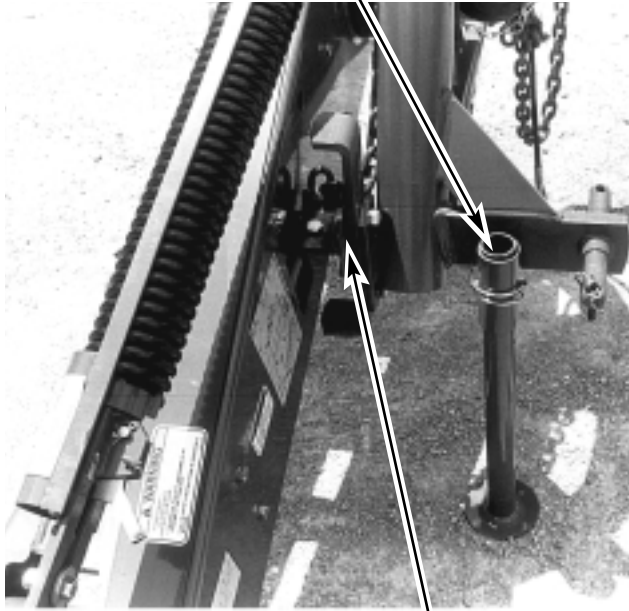

Figure 4

Front Support Leg



Apply Grease At Contact Points

7. Fasten curtain frame upright bracket to gearbox using (3) 12 x 30mm bolts, and (1) 12 x 40mm bolt. The 12 x 40mm bolt is located in the bottom rear hole. Leave this bolt loose as it will be used to fasten other components together. (Figure 5)

Figure 5

Pawl

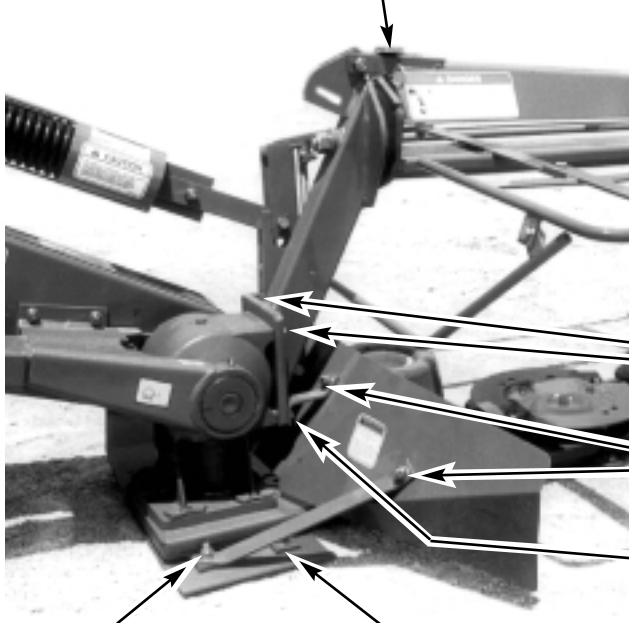

12 - 40 mm Plow Bolt 12 - 35mm Plow Bolt

8. At this point the bottom shipping frame should be removed so as not to interfere with installation of the gearbox skid and swathboard. Save the fasteners removed from the bottom of the cutter bar as they will be used later at the same location.

9. Install gearbox skid, then gearbox swathboard using the 12 x 40mm bolt that was left loose previously. Use two bolts at front to connect skid and swathboard. (Figure 6) At the rear side of gearbox, use twisted strut to connect skid and swathboard. (Figure 7)

Figure 6 Swathboard

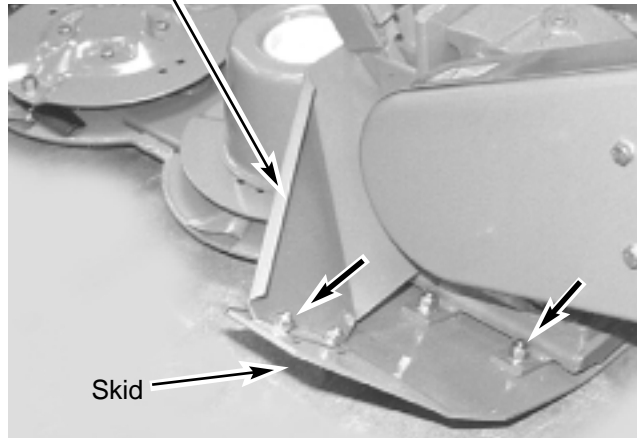
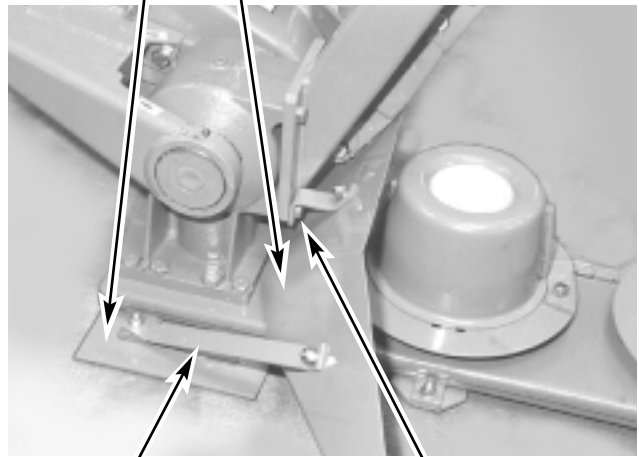

Figure 7 Skid Swathboard



Twisted Strut 12-40 mm

12 - 30 mm (3)
(Also Bottom Front - Not Seen)

10 x 25 mm

12 - 40 mm

10. Remove pin from top of three point lift frame to allow installation of stabilizer cylinder assembly. (Figure 8)

Attach Hydraulic Hose With Clamp

Figure 8 Cylinder Mounting Hole Locations

Model HM2009 Models HM2007 & HM2008

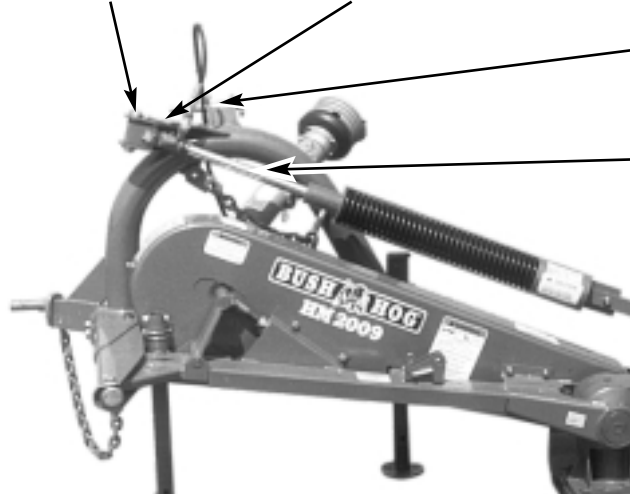

Before mounting stabilizer, pull out the piston/rod of the hydraulic cylinder.

11. Remove pin from lower connection link and stop link to allow installation of lower end of stabilizer.

12. Pin stabilizer in appropriate top hole according to size of cutter bar. (Figure 8) Also refer to decal on machine.

13. Pull out hydraulic cylinder rod (Open hydraulic valve and release poppet in end of hydraulic line) and assemble to connection link and stop link at lower end. Refer to photograph and illustration for correct hole. (Figure 9)

Figure 9

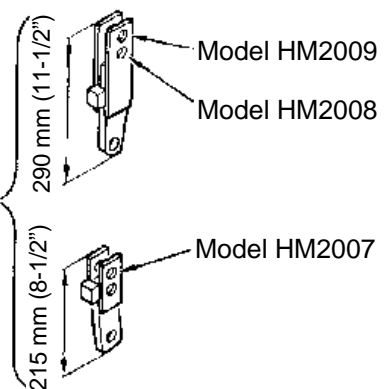

14. Remove bolts from hubs to allow installation of blade cutting discs. (Figure 10) Refer to illustration on next page for correct positioning of blade cutting discs. Pay particular attention to blade rotation and arrange discs at 90° to each other. NOTE: The end discs (outer end only on 7' model) use longer bolts to also hold the cones in place and the nut guards on the cone discs are "cut out" for clearance. A snap-in plastic cap is provided for each cone.

Figure 10

Green - NOTE: Only used with flat blade kit

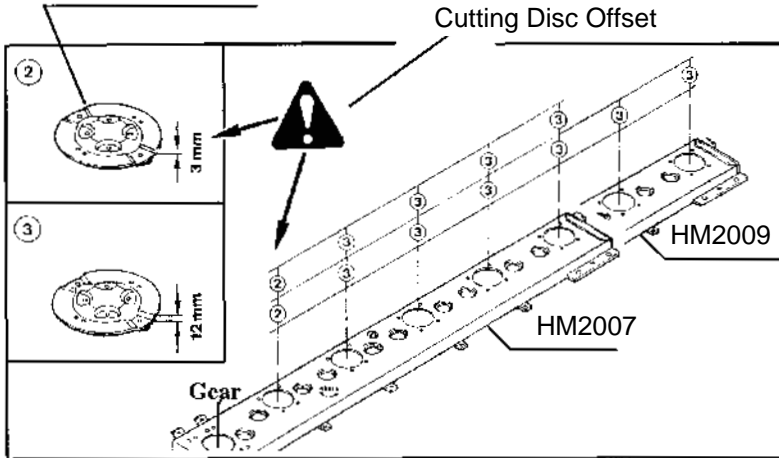

Note the correct mounting of the cutting disc which is to be 3 mm offset.

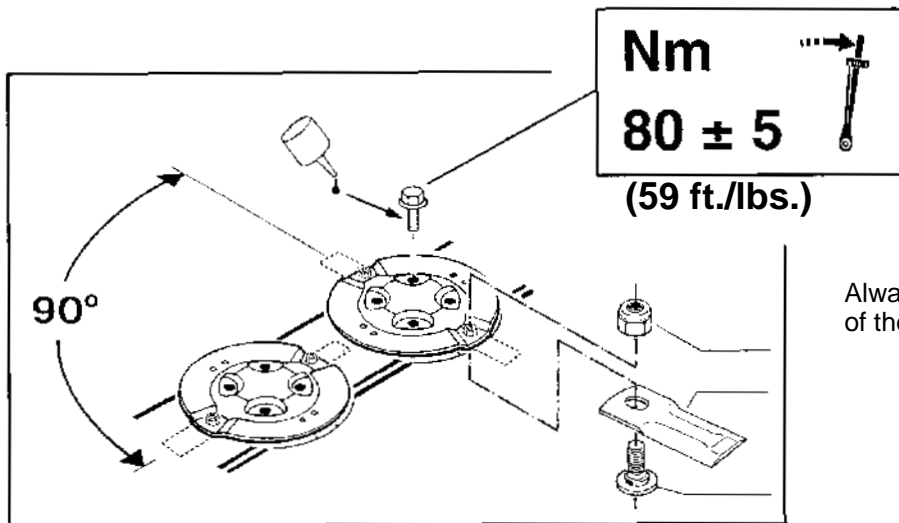

Always use LOCKTITE 242 on the bolts of the cutting discs.

Models HM2007, HM2008, HM2009
(Outside Crop Divider)

Models HM2008, HM2009
(Inside Crop Divider)

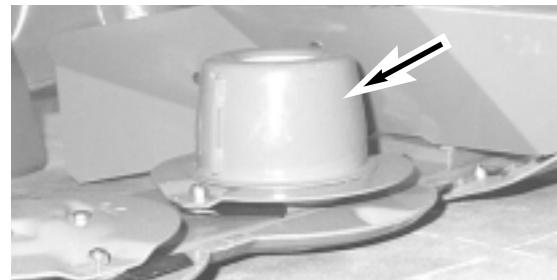

CUTTING DISCS ARRANGEMENT



A

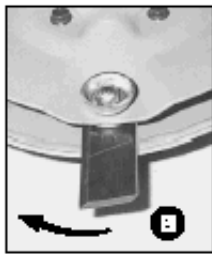

B

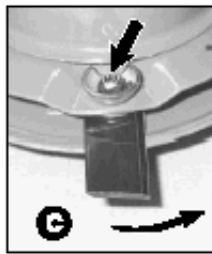

C

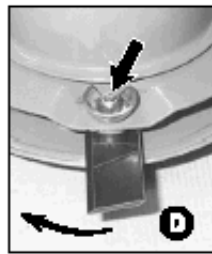

D

D

Blade Rotation

Model
HM2009

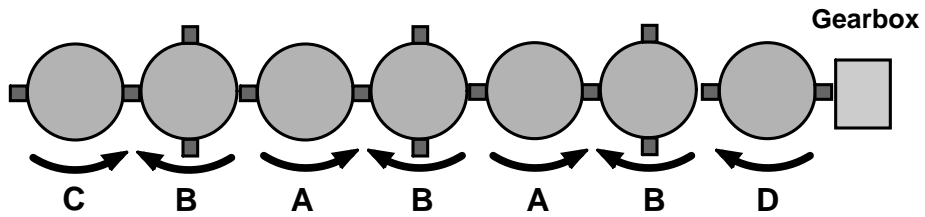

Working Direction

Model
HM2008

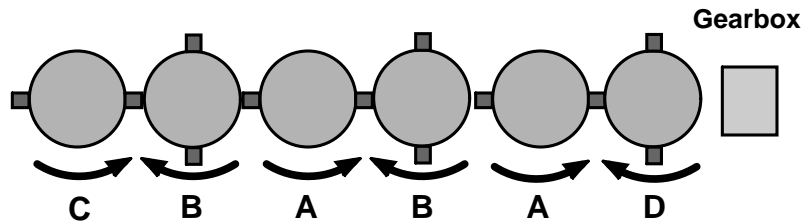

Working Direction

Model
HM2007

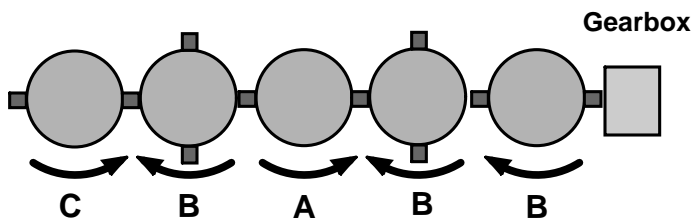

Working Direction

15. Assemble curtain frame as shown in (Figure 11). **Do not attach curtain frame to upright bracket at this time.**

Figure 11 Curtain Frame

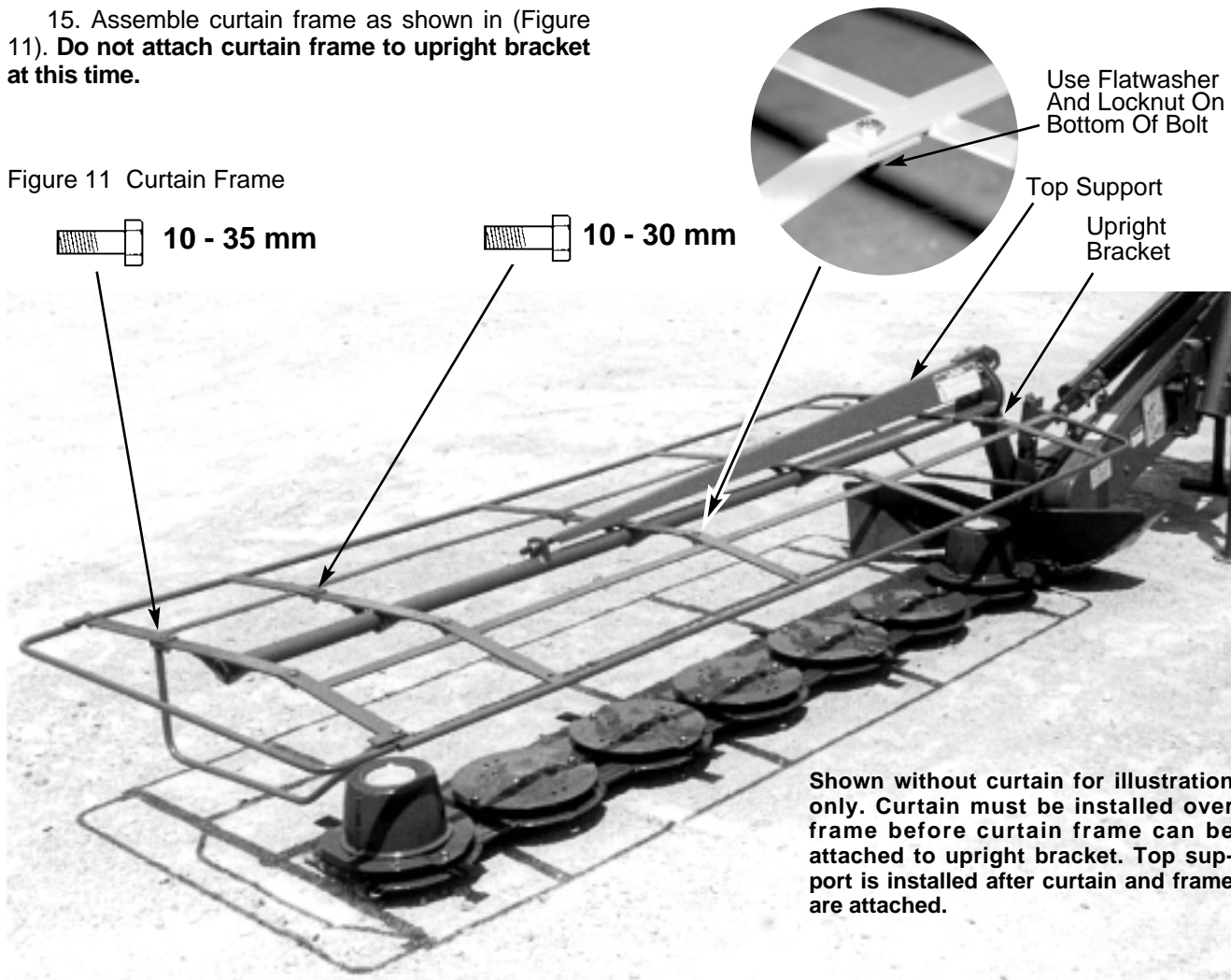

16. Place curtain over frame. Connect curtain frame to upright mount with rubber and metal discs "sandwiched" between the frame and mount. (Figure 12) Tighten "snug", but allow to rotate.

Figure 12 Attaching Curtain Frame To Upright



17. Fasten rails to ends of frame as shown in (Figures 13, 14 and 15). Note that the rail on the inside end of the frame must be inserted through loops in the curtain. (Figure 13)

Figure 13

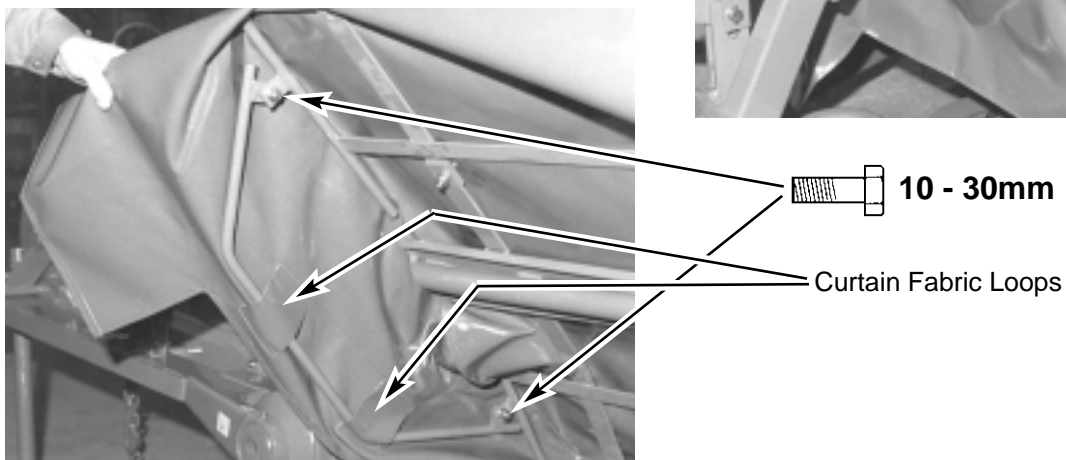

18. Attach front edge rail to frame. (Figure 14)

19. Install top support over curtain and frame. (Figure 16) Note that pawl must be inserted into place
Figure 14

before inner end of support is bolted to the upright bracket. (Refer to Figures 5 & 11) Fasten curtain to frame with bolts and flat washers as shown. (Figure 16)

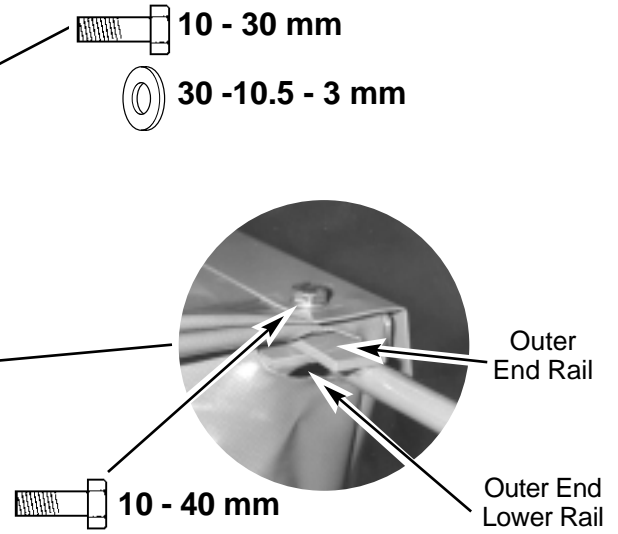
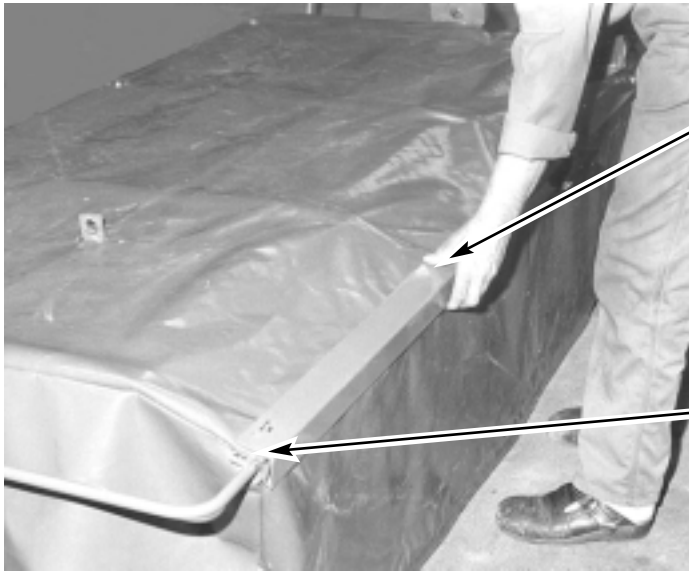
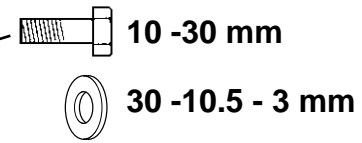

Figure 15



20. Attach limit chain and circular shield as shown in (Figure 17).

21. Attach Slow Moving Vehicle (SMV) bracket to three point lift hitch as shown. (Figure 18)

22. While leaving slack in hydraulic hose, clamp it to the three point lift hitch. (Figure 8)

23. Slide overrunning clutch end of driveline onto

input shaft of hay mower. Insure that clutch end snaps into place.

24. The hook end of the safety chain will be attached to the tractor after the hay mower is mounted to the tractor three point hitch. The free end of the chain is then inserted through the bracket on the hitch frame of the hay mower. The loose end may then be reinserted back through the bracket to capture the chain.(Figure 17)

Figure 16 Top Support

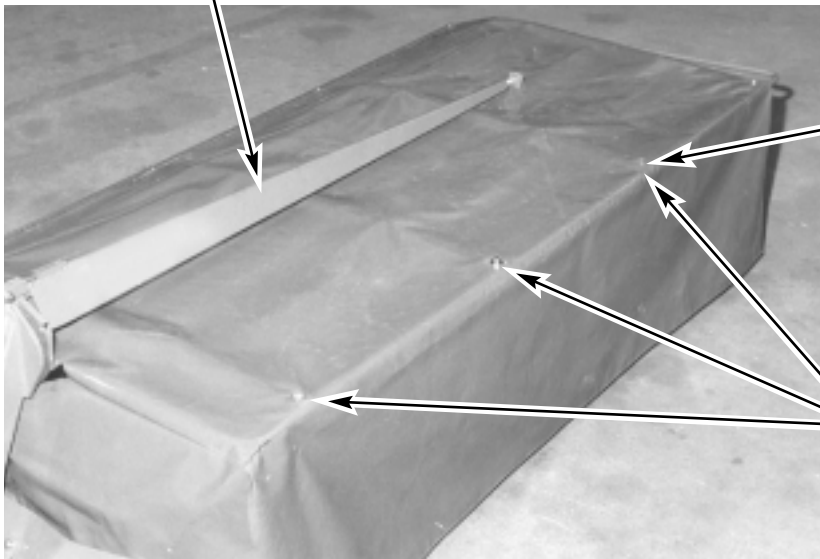



 **10 -30 mm**
 **30 - 10.5 - 3 mm**

Figure 17 Retaining Spring

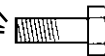

 **12 -40 mm**
12 - 40 mm
 Limit Chain
 Circular Shield
 Safety Chain

Figure 18 Slow Moving Vehicle Sign (SMV) Assembly

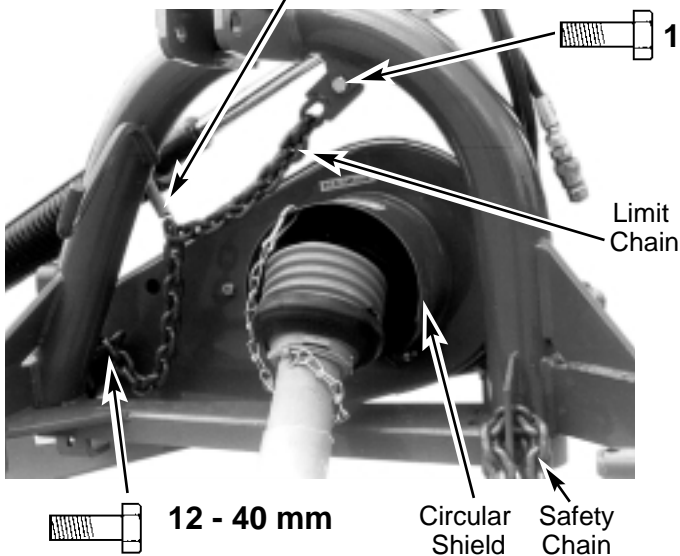

OPTIONAL EQUIPMENT

Left Hand Swath Wheel

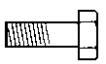
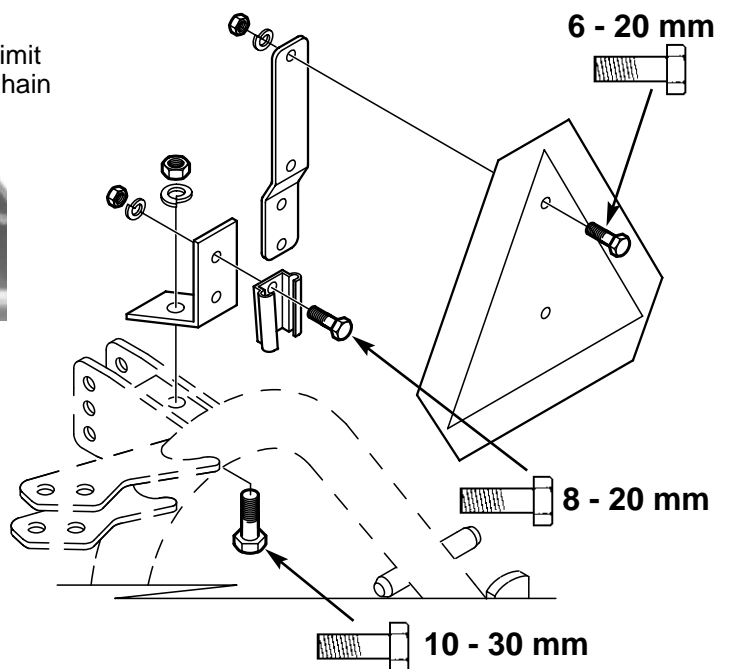
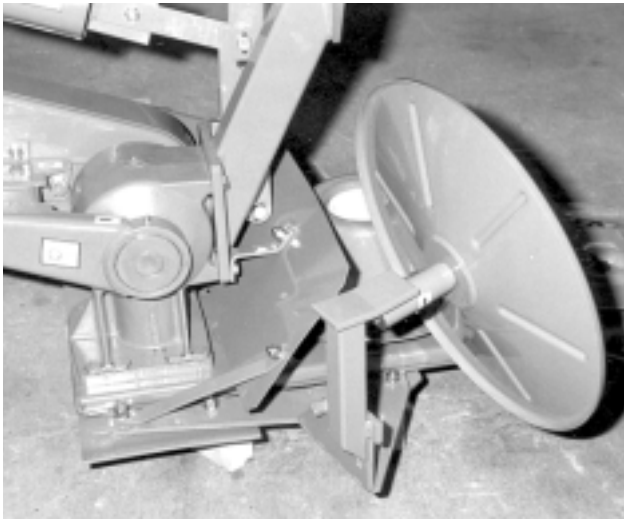

Right Hand Swath Wheel



Right Hand Swathboard

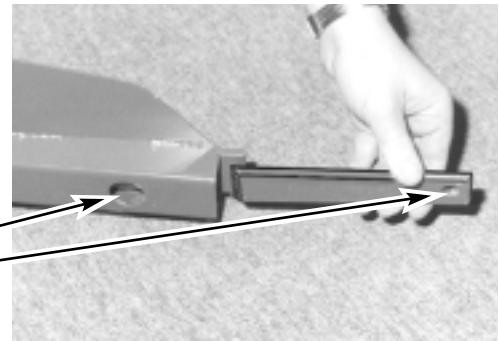
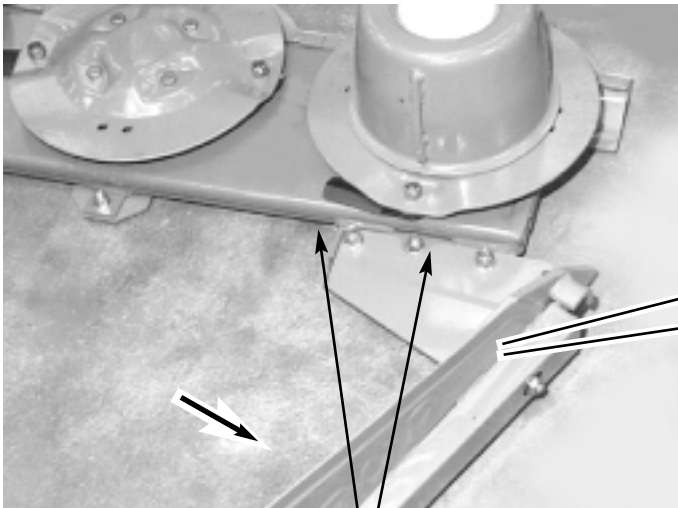

(Shipped preassembled)

12 - 35mm

(Shipped from factory with bolts in mounting bracket)

SAFETY DECALS

To promote safe operation, Bush Hog supplies safety decals on all products manufactured. Because damage can occur to safety decals either through shipment, use or reconditioning, Bush Hog will, upon request, provide safety decals for any of our products in the field at no charge. Contact your authorized Bush Hog dealer for more information.

WARNING

IMPLEMENT IS UNSTABLE WHEN UNHITCHED WITH CUTTER BAR IN TRANSPORT OR RAISED POSITION

TO AVOID SERIOUS INJURY OR DEATH FROM IMPLEMENT OVERTURN:

ALWAYS UNHITCH AND STORE MOWER WITH CUTTER BAR IN THE UNFOLDED OR HORIZONTAL POSITION.

50030640

WARNING

ROTATING MACHINE PARTS TO AVOID SERIOUS INJURY OR DEATH:

- KEEP ALL PERSONS CLEAR OF OPERATING MOWER AND MOWING AREA.
- KEEP CLEAR OF ROTATING BLADES, PARTS AND DRIVELINES.

50030641

WARNING

IMPLEMENT CAN FALL WITHOUT SUPPORT TO AVOID SERIOUS INJURY OR DEATH:

- SHUT OFF TRACTOR ENGINE, REMOVE KEY, SECURE TRACTOR PARKING BRAKE AND BLOCK UP OR SECURELY SUPPORT IMPLEMENT BEFORE WORKING UNDERNEATH.

50030642

DANGER

ROTATING DRIVELINE CONTACT CAN CAUSE DEATH
KEEP AWAY!

DO NOT OPERATE WITHOUT-

- ALL DRIVELINE, TRACTOR AND EQUIPMENT SHIELDS IN PLACE.
- DRIVELINES SECURELY ATTACHED AT BOTH ENDS.
- DRIVELINE SHIELDS THAT TURN FREELY ON DRIVELINE.

50030644

DANGER

KEEP AWAY - ROTATING BLADES

TO AVOID SERIOUS INJURY OR DEATH FROM BLADE CONTACT AND THROWN OBJECTS:

- USE ROPS (ROLLOVER PROTECTIVE STRUCTURES) AND SEAT BELT EQUIPPED TRACTOR TO PREVENT ACCIDENTAL FALL OFF FROM TRACTOR AND SERIOUS INJURY OR DEATH FROM RUN OVER OR ROLLOVER BY TRACTOR OR MOWER.
- BUCKLE UP SEAT BELT.
- ALLOW NO RIDERS ON TRACTOR OR MOWER.
- KEEP ALL PERSONS CLEAR OF OPERATING MOWER AND MOWING AREA.
- KEEP CURTAIN GUARD IN PLACE AND IN GOOD CONDITION.
- DO NOT OPERATE MOWER WITH CURTAIN GUARD REMOVED.

50030643

! DANGER



**SHIELD MISSING
DO NOT OPERATE**

50030645

! WARNING

**ROTATING DRIVE PARTS
BENEATH**

- ENTANGLEMENT WITH ROTATING DRIVE PARTS CAN CAUSE INJURY OR DEATH.
- DO NOT OPERATE WITHOUT THIS AND ALL OTHER SHIELDS IN PLACE AND IN GOOD CONDITION.

50030646

! WARNING



TO AVOID SERIOUS INJURY OR DEATH:

- LOCK CUTTER BAR UP FOR TRANSPORT
- INSTALL TRANSPORT LOCK PINS
- READ OPERATORS MANUAL FOR INSTRUCTIONS

50030647

! WARNING

**HYDRAULIC STABILIZER SPRING HAS
STORED ENERGY THAT CAN SUDDENLY RELEASE
TO AVOID SERIOUS INJURY OR DEATH BY UN-
CONTROLLED RELEASE OF SPRING STORED ENERGY:**

- USE SPECIAL TOOLS TO DISASSEMBLE OR ASSEMBLE THE STABILIZER.
- FOLLOW SAFETY INSTRUCTIONS IN OPERATOR'S MANUAL.

50030649

! DANGER



KEEP AWAY - CURTAIN GUARD MISSING - DO NOT OPERATE

50030648

DANGER



KEEP AWAY!

SHIELD MISSING FROM THIS AREA
TO AVOID SERIOUS INJURY OR DEATH,
DO NOT OPERATE WITHOUT THIS AND
ALL OTHER SHIELDS IN PLACE AND IN
GOOD CONDITION.

50030654

CAUTION

BE SURE TO PURGE ALL THE AIR FROM
THE HYDRAULIC SYSTEM BEFORE
ATTEMPTING TO RAISE OR LOWER
THIS MACHINE. REFER TO OWNERS
MANUAL FOR FURTHER DETAILS.

50030651

WARNING



TO AVOID SERIOUS INJURY OR DEATH:

- READ OPERATOR'S MANUAL BEFORE OPERATING AND FOLLOW ALL PRECAUTIONS. (CONTACT DEALER FOR MANUAL)
- KEEP SHIELDS AND GUARDS IN PLACE. KEEP CLEAR OF DRIVES AND BELTS.
- LOWER IMPLEMENT, STOP ENGINE AND PTO, ALLOW ALL MOVING PARTS TO STOP, AND REMOVE KEY BEFORE DISMOUNTING FROM TRACTOR.
- KNOW HOW TO STOP TRACTOR AND EQUIPMENT QUICKLY IN AN EMERGENCY.
- ALLOW NO CHILDREN OR UNQUALIFIED PERSONS TO OPERATE EQUIPMENT.
- BE CAREFUL ON UNEVEN TERRAIN. DECREASE SPEED WHEN TURNING.
- DO NOT OPERATE MOWER IN TRANSPORT POSITION.

50030652

WARNING



TO AVOID SERIOUS INJURY OR DEATH:

- ONLY OPERATE WITH CUTTER BAR IN GROUND CONTACT POSITION.
- STAND CLEAR IF LOWERING OR RAISING CUTTER BAR.
- BE ALERT TO OVERHEAD OBSTRUCTIONS AND ELECTRICAL WIRES WITH CUTTER BAR IN RAISED POSITION.
- PURGE ALL AIR FROM HYDRAULIC SYSTEM BEFORE ATTEMPTING TO RAISE OR LOWER THIS IMPLEMENT.
- DO NOT USE HAND OR SKIN TO CHECK FOR HYDRAULIC LEAKS, USE CARDBOARD OR WOOD.
- HIGH PRESSURE OIL LEAKS CAN PENETRATE SKIN CAUSING SERIOUS INJURY AND GANGRENE. CONSULT A PHYSICIAN IMMEDIATELY.
- LOWER THE IMPLEMENT AND RELEASE HYDRAULIC PRESSURE BEFORE LOOSENING FITTINGS.

50030650

CAUTION

THIS IMPLEMENT IS DESIGNED TO OPERATE
AT 540 RPM MAXIMUM TRACTOR PTO SPEED.

ALL DRIVE LINE SHIELDS MUST BE KEPT IN
PLACE.

50030653



BUSH HOG[®], L.L.C.

**P.O. Box 1039 • Selma, AL 36702-1039
Telephone (334) 872-6261**

Free Manuals Download Website

<http://myh66.com>

<http://usermanuals.us>

<http://www.somanuals.com>

<http://www.4manuals.cc>

<http://www.manual-lib.com>

<http://www.404manual.com>

<http://www.luxmanual.com>

<http://aubethermostatmanual.com>

Golf course search by state

<http://golfingnear.com>

Email search by domain

<http://emailbydomain.com>

Auto manuals search

<http://auto.somanuals.com>

TV manuals search

<http://tv.somanuals.com>