

BUSH HOG®

RFM 60

Rear Finishing Mower Operator's Manual



BUSH HOG®
Performance You Can Count On™

ASSEMBLY ● OPERATION ● MAINTENANCE

CONGRATULATIONS!

You have invested in the best implement of its type on the market today.

The care you give your Bush Hog implement will greatly determine your satisfaction with its performance and its service life. We urge a careful study of this manual to provide you with a thorough understanding of your new implement before operating, as well as suggestions for operation and maintenance.

If your manual should become lost or destroyed, Bush Hog will be glad to provide you with a new copy. Order from Bush Hog, 2501 Griffin Ave., Selma, Alabama 36703. Most of our manuals can also be downloaded from our website at www.bushhog.com.

As an authorized Bush Hog dealer, we stock genuine Bush Hog parts which are manufactured with the same precision and skill as our original equipment. Our trained service personnel are well informed on methods required to service Bush Hog equipment, and are ready and able to help you.

Should you require additional information or assistance, please contact us.

YOUR AUTHORIZED
BUSH HOG DEALER

BECAUSE BUSH HOG MAINTAINS AN ONGOING PROGRAM OF PRODUCT IMPROVEMENT, WE RESERVE THE RIGHT TO MAKE IMPROVEMENTS IN DESIGN OR CHANGES IN SPECIFICATIONS WITHOUT INCURRING ANY OBLIGATION TO INSTALL THEM ON UNITS PREVIOUSLY SOLD.

BECAUSE OF THE POSSIBILITY THAT SOME PHOTOGRAPHS IN THIS MANUAL WERE TAKEN OF PROTOTYPE MODELS, PRODUCTION MODELS MAY VARY IN SOME DETAIL. IN ADDITION, SOME PHOTOGRAPHS MAY SHOW SHIELDS REMOVED FOR PURPOSES OF CLARITY. **NEVER OPERATE** THIS IMPLEMENT WITHOUT ALL SHIELDS IN PLACE.

RFM 60

Operator's Manual

TABLE OF CONTENTS

SECTION/PARA	PAGE	SECTION/PARA	PAGE
Warranty	2	3-3 Operation	10
Dealer Preparation Check List	3	3-4 Transporting	10
Safety Precautions	4		
Federal Laws and Regulations	6	IV MAINTENANCE	11
I INTRODUCTION AND DESCRIPTION ..7		4-1 Maintenance Check List	11
1-1 Introduction	7	4-2 Lubrication	11
1-2 Description	7	4-3 Belt Adjustment	12
II PREPARATION FOR USE	8	4-4 Belt Replacement	12
2-1 Attaching to Tractor	8	4-5 Blade Replacement	13
III OPERATING INSTRUCTIONS	10	4-6 Troubleshooting	13
3-1 General Safety	10	V DEALER ASSEMBLY	14
3-2 Cutting Height Adjustment	10	5-1 Base Unit Assembly	14
		Safety Decals	16
		Torque Specifications	17

RETAIL CUSTOMER'S RESPONSIBILITY UNDER THE BUSH HOG WARRANTY

It is the Retail Customer and/or Operator's responsibility to read the Operator's Manual, to operate, lubricate, maintain and store the product in accordance with all instructions and safety procedures. Failure of the operator to read the Operator's Manual is a misuse of this equipment.

It is the Retail Customer and/or Operator's responsibility to inspect the product and to have any part(s) repaired or replaced when continued operation would cause damage or excessive wear to other parts or cause a safety hazard.

It is the Retail Customer's responsibility to deliver the product to the authorized Bush Hog Dealer, from whom he purchased it, for service or replacement of defective parts which are covered by warranty. Repairs to be submitted for warranty consideration must be made within forty-five (45) days of failure.

It is the Retail Customer's responsibility for any cost incurred by the Dealer for traveling to or hauling of the product for the purpose of performing a warranty obligation or inspection.



BUSH HOG®
Performance You Can Count OnSM

LIMITED WARRANTY



Bush Hog warrants to the original purchaser of any new Bush Hog equipment, purchased from an authorized Bush Hog dealer, that the equipment be free from defects in material and workmanship for a period of one (1) year for non-commercial, state and municipalities' use and ninety (90) days for commercial use from date of retail sale. Model RFM gearboxes are covered by a five (5) year limited warranty period. The obligation of Bush Hog to the purchaser under this warranty is limited to the repair or replacement of defective parts.

Replacement or repair parts installed in the equipment covered by this limited warranty are warranted for ninety (90) days from the date of purchase of such part or to the expiration of the applicable new equipment warranty period, whichever occurs later. Warranted parts shall be provided at no cost to the user at an authorized Bush Hog dealer during regular working hours. Bush Hog reserves the right to inspect any equipment or parts which are claimed to have been defective in material or workmanship.

DISCLAIMER OF IMPLIED WARRANTIES & CONSEQUENTIAL DAMAGES

Bush Hog's obligation under this limited warranty, to the extent allowed by law, is in lieu of all warranties, implied or expressed, **INCLUDING IMPLIED WARRANTIES OF MERCHANTABILITY AND FITNESS FOR A PARTICULAR PURPOSE** and any liability for incidental and consequential damages with respect to the sale or use of the items warranted. Such incidental and consequential damages shall include but not be limited to: transportation charges other than normal freight charges; cost of installation other than cost approved by Bush Hog; duty; taxes; charges for normal service or adjustment; loss of crops or any other loss of income; rental of substitute equipment, expenses due to loss, damage, detention or delay in the delivery of equipment or parts resulting from acts beyond the control of Bush Hog.

THIS LIMITED WARRANTY SHALL NOT APPLY:

1. To vendor items which carry their own warranties, such as engines, tires, and tubes.
2. If the unit has been subjected to misapplication, abuse, misuse, negligence, fire or other accident.
3. If parts not made or supplied by Bush Hog have been used in connection with the unit, if, in the sole judgement of Bush Hog such use affects its performance, stability or reliability.
4. If the unit has been altered or repaired outside of an authorized Bush Hog dealership in a manner which, in the sole judgement of Bush Hog, affects its performance, stability or reliability.
5. To normal maintenance service and normal replacement items such as gearbox lubricant, hydraulic fluid, worn blades, or to normal deterioration of such things as belts and exterior finish due to use or exposure.
6. To expendable or wear items such as teeth, chains, sprockets, belts, springs and any other items that in the company's sole judgement is a wear item.

NO EMPLOYEE OR REPRESENTATIVE OF BUSH HOG IS AUTHORIZED TO CHANGE THIS LIMITED WARRANTY IN ANY WAY OR GRANT ANY OTHER WARRANTY UNLESS SUCH CHANGE IS MADE IN WRITING AND SIGNED BY BUSH HOG'S SERVICE MANAGER, 2501 GRIFFIN AVE., SELMA, ALABAMA 36703.



Record the model number, serial number and date purchased. This information will be helpful to your dealer if parts or service are required.

MODEL NUMBER _____

SERIAL NUMBER _____

MAKE CERTAIN THE WARRANTY INFORMATION HAS BEEN FILED ONLINE WITH BUSH HOG SELMA, ALABAMA.

DATE OF RETAIL SALE _____

DEALER PREPARATION CHECK LIST

RFM 60 Finishing Mowers

BEFORE DELIVERING MACHINE — The following check list should be completed.
Use the Operator's Manual as a guide.

- 1. Assembled completed.
- 2. Gearboxes filled with oil.
- 3. All fittings lubricated.
- 4. All shields in place and in good condition.
- 5. All fasteners torqued to specifications given in Torque Chart
- 6. All decals in place and readable. (See decal page.)
- 7. Overall condition good (i.e. paint, welds)
- 8. Operators manual has been delivered to owner and he has been instructed on the safe and proper use of the cutter.
- 9. Warranty information has been registered online with Bush Hog.

Dealer's
Signature _____

Purchaser's
Signature _____

THIS CHECKLIST TO REMAIN IN OWNER'S MANUAL
It is the responsibility of the dealer to complete the procedures listed
above before delivery of this implement to the customer.

Safety Alert Symbol



This Safety Alert Symbol means: “**ATTENTION! BECOME ALERT! YOUR SAFETY IS INVOLVED!**”

This symbol is used to call attention to safety precautions that should be followed by the operator to avoid accidents. When you see this symbol, carefully read the message that follows and heed its advice. Failure to comply with safety precautions could result in death or serious bodily injury.

Safety Signs *Signal Words*

The signal words **DANGER, WARNING, AND CAUTION** are used on the equipment safety signs. These words are intended to alert the viewer to the existence and the degree of hazard seriousness.

 **DANGER**

White letters on **RED**

This signal word indicates a potentially hazardous situation which, if not avoided, will result in death or serious injury.

 **WARNING**

Black letters on **ORANGE**

This signal word indicates a potentially hazardous situation which, if not avoided, could result in death or serious injury

It may also be used to alert against unsafe practices.

 **CAUTION**

Black letters on **YELLOW**

This signal word indicates a potentially hazardous situation exist which, if not avoided, may result in minor or moderate injury.

It may also be used to alert against unsafe practices.

IMPORTANT SAFETY PRECAUTIONS

This symbol is used to call attention to safety precautions that should be followed by the operator to avoid accidents. When you see this symbol, carefully read the message that follows and heed its advice. Failure to comply with safety precautions could result in death or serious bodily injury.



In addition to the design and configuration of equipment, hazard control and accident prevention are dependent upon the awareness, concern, prudence and proper training of personnel in the operation, transport, maintenance and storage of equipment. Lack of attention to safety can result in accident, personal injury, reduction of efficiency and worst of all—loss of life. Watch for safety hazards and correct deficiencies promptly. Use the following safety precautions as a general guide to safe operations when using this machine. Additional safety precautions are used throughout this manual for specific operating and maintenance procedures. Read this manual and review the safety precautions often until you know the limitations.

1. Read the Operator's Manual. Failure to read the Operator's Manual is considered a misuse of this equipment.
2. Become familiar with all the machine's controls and all the caution, warning and danger decals affixed to the machine before attempting to start or operate.
3. Before starting or operating the machine, make a walk around inspection and check for obvious defects such as loose mounting bolts and damaged components. Correct any deficiency before starting.
4. Do not allow children to operate the cutter. Do not allow adults to operate it without proper instruction.
5. Do not carry passengers.
6. Keep the area of operation clear of all persons, particularly small children and pets. The operator should cease mowing whenever anyone comes within the operating area.
7. Clear the work area of objects which might be picked up and thrown.
8. Use a piece of cardboard or wood rather than hands to search for hydraulic leaks. Escaping hydraulic oil under pressure can penetrate skin. If fluid is injected into the skin, it must be surgically removed within a few hours by a doctor familiar with this form of injury or gangrene may result.
9. Do not operate without all guards and shields in place and in good condition.
10. Lower implement to ground, stop tractor engine, apply parking brake, and allow blades to completely stop before leaving the tractor.
11. Keep hands and feet away from blades.
12. This cutter is not to be operated along highways or in any area where people may be present unless all sides of the unit are enclosed by permanent bands, safety chains or other factory approved safety shields that are in good repair.
13. Wear personal protective equipment such as, but not limited to, protection for eyes, ears, feet, hands and head when operating or repairing the equipment. Do not wear loose clothing or jewelry that may catch on equipment moving parts.
14. When performing adjustments or maintenance on the cutter, first lower it to the ground or block it securely at a workable height.
15. Never stand between tractor and cutter while tractor is being backed to the cutter hitch.
16. Reduce speed when transporting cutter to avoid bouncing and momentary loss of steering.
17. Use tractor flashing warning lights, day or night, when transporting cutter on road or highways unless prohibited by law.
18. It is recommended that tractor be equipped with Rollover Protective System (ROPS) and seat belt be used in all mowing operations.

IMPORTANT FEDERAL LAWS AND REGULATIONS* CONCERNING EMPLOYERS, EMPLOYEES AND OPERATIONS.

*(This section is intended to explain in broad terms the concept and effect of the following federal laws and regulations. It is not intended as a legal interpretation of the laws and should not be considered as such).

U.S. Public Law 91-596 (The Williams-Steiger Occupational and Health Act of 1970) OSHA

This Act Seeks:

"...to assure so far as possible every working man and woman in the nation safe and healthful working conditions and to preserve our human resources..."

DUTIES

Sec. 5 (a) Each employer—

- (1) shall furnish to each of his employees employment and a place of employment which are free from recognized hazards that are causing or are likely to cause death or serious physical harm to his employees;
- (2) shall comply with occupational safety and health standards promulgated under this Act.
 - (b) Each employee shall comply with occupational safety and health standards and all rules, regulations and orders issued pursuant to this Act which are applicable to his own actions and conduct.

OSHA Regulations

Current OSHA regulations state in part: "At the time of initial assignment and at least annually thereafter, the employer shall instruct every employee in the safe operation and servicing of all equipment with which the employee is, or will be involved." These will include (but are not limited to) instructions to:

Keep all guards in place when the machine is in operation;

Permit no riders on equipment;

Stop engine, disconnect the power source, and wait for all machine movement to stop before servicing, adjusting, cleaning or unclogging the equipment, except where the machine must be running to be properly serviced or maintained, in which case the employer shall instruct employees as to all steps and procedures which are necessary to safely service or maintain the equipment.

Make sure everyone is clear of machinery before starting the engine, engaging power, or operating the machine.

EMPLOYEE TRACTOR OPERATING INSTRUCTIONS:

1. Securely fasten your seat belt if the tractor has a ROPS.
2. Where possible, avoid operating the tractor near ditches, embankments, and holes.
3. Reduce speed when turning, crossing slopes, and on rough, slick, or muddy surfaces.
4. Stay off slopes too steep for safe operation.
5. Watch where you are going, especially at row ends, on roads, and around trees.
6. Do not permit others to ride.
7. Operate the tractor smoothly - no jerky turns, starts, or stops.
8. Hitch only to the drawbar and hitch points recommended by tractor manufacturers.
9. When tractor is stopped, set brakes securely and use park lock if available.

Child Labor Under 16 Years Old

Some regulations specify that no one under the age of 16 may operate power machinery. It is your responsibility to know what these regulations are in your own area or situation. (Refer to U.S. Dept. of Labor, Employment Standard Administration, Wage & Home Division, Child Labor Bulletin #102.)

SECTION I INTRODUCTION AND DESCRIPTION

1-1 INTRODUCTION

We are pleased to have you as a Bush Hog customer. Your RFM Rotary Cutter has been carefully designed to give maximum service with minimum down time. This manual is provided to give you the necessary operating and maintenance instructions for keeping your rotary cutter in top operating condition. Please read this manual thoroughly. Understand what each control is for and how to use it. Observe all safety precautions decaled on the machine and noted throughout the manual for safe operation of implement. If any assistance or additional information is needed, contact your authorized Bush Hog dealer.

NOTE

All references made to right, left, top, bottom, front or rear are as viewed facing the direction of travel with implement properly attached to tractor.

1-2 DESCRIPTION

The RFM cutters (Figure 1-1) are intended for cutting lawns or any maintained area where a clean, uniform finish is desired. Parallel uplift blades form a

suction during operation to lift the grass before cutting it. The four caster wheel arrangement, along with the floating top lift linkage work together to give an even cut and minimize scalping.

Power from the tractor is transmitted through a triangular, telescoping driveline to the 90 degree gear-box. It is then passed to the spindle housings and blades by a single, B-section, Kevlar reinforced belt. Drivetrain protection is provided by belt slippage.

Table 1-1 RFM Specifications

	RFM 60
Cutting Width (in.)	60
Cutting Height (in.)	1-1/2 to 6-1/2
Horsepower Range	14 - 30
Blade Tip Speed (fpm)	18,500
Weight (lbs.)	450

Figure 1-1 RFM 60

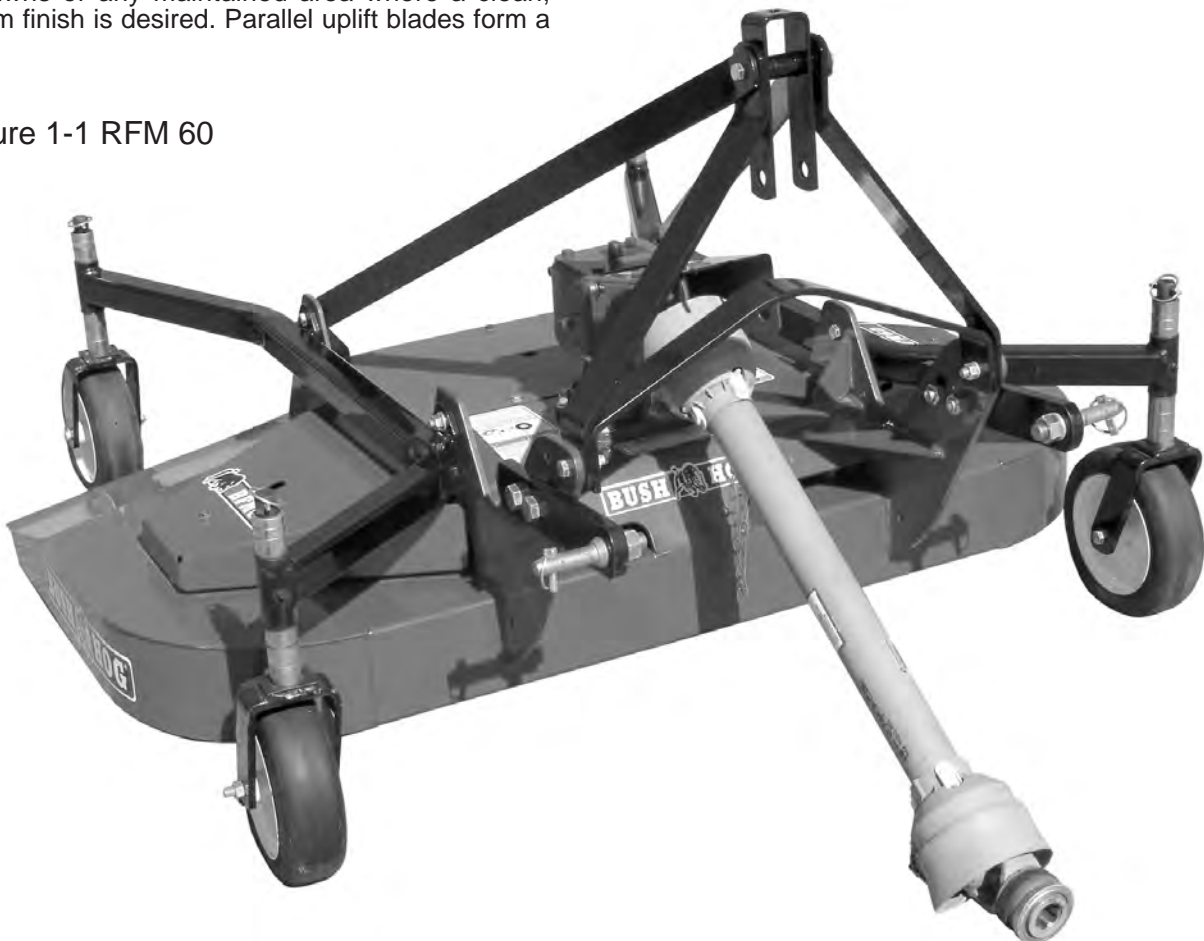

SECTION II PREPARATION FOR USE

2-1 ATTACHING TO TRACTOR

⚠ WARNING

NEVER STAND BETWEEN TRACTOR AND CUTTER WHILE TRACTOR IS BEING BACKED TO HITCH.

⚠ WARNING

ADDITIONAL TRACTOR FRONT BALLAST MAY BE NEEDED FOR STABLE OPERATION AND TRANSPORT OF CUTTER. SEE TRACTOR OPERATOR'S MANUAL FOR RECOMMENDED WEIGHTS. IT IS RECOMMENDED THAT TRACTOR BE EQUIPPED WITH ROLLOVER PROTECTIVE SYSTEM (ROPS) AND SEAT BELTS.

A. Attach to tractor Cat. I three point hitch as described in tractor operator's manual.



Figure 2-1



NOTE

Due to the many variations in tractor/implement hitch points and corresponding differences in distances between tractor PTO shafts and implement input shafts, drivelines may need to be shortened as described in the following steps:

B. Raise and lower cutter to determine position with shortest distance between the tractor PTO shaft and gearbox input shaft. Shut down tractor leaving cutter in position of shortest distance. **SECURELY BLOCK CUTTER IN POSITION.**

C. Pull driveline apart. Attach outer (female) section to tractor PTO shaft. Pull on driveline section to be sure yoke locks into place.

D. Hold driveline sections parallel to each other to determine if too long. Each section should end approximately 3 inches (76mm) short of reaching universal joint shield on opposite section. If too long, measure 3 inches (76mm) back from universal joint shield and mark opposite section. (Figure 2-1). Do this for both sections.

E. Raise and lower cutter to determine position with greatest distance between PTO shaft and gearbox input shaft. Shut down tractor leaving cutter in position of greatest distance. **SECURELY BLOCK CUTTER IN POSITION.**

F. Hold down driveline sections parallel to each other and check for minimum 6 inches (152mm) overlap. (Figure 2-2) If driveline has been marked for cutting, overlap will be the distance between two marks. If driveline has less than minimum overlap, **DO NOT USE.** Contact authorized Bush Hog dealer.

NOTE

If driveline is correct length, omit the following steps "G" through "J" and proceed to step "K".

Figure 2-2

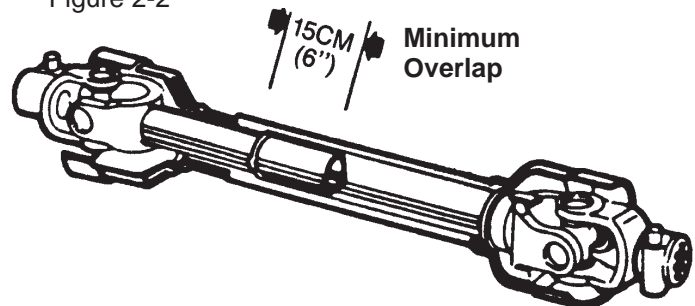

G. Clamp end of driveline in a vice. Cut off shield where marked. (Figure 2-3).

Figure 2-3



H. Using cut off section of shield as a guide, cut shaft the same amount. (Figure 2-4)

Figure 2-4



I. Repeat steps "G" and "H" to other driveline section.

J. Deburr ends of driveline sections and clean away all chips and filings. (Figure 2-5)

K. Apply multi-purpose grease to outside of male driveline section. Assemble driveline and install on tractor and cutter. Pull on each driveline section to be sure yokes lock into place. Make certain driveline shielding is in place and in good condition.

Figure 2-5

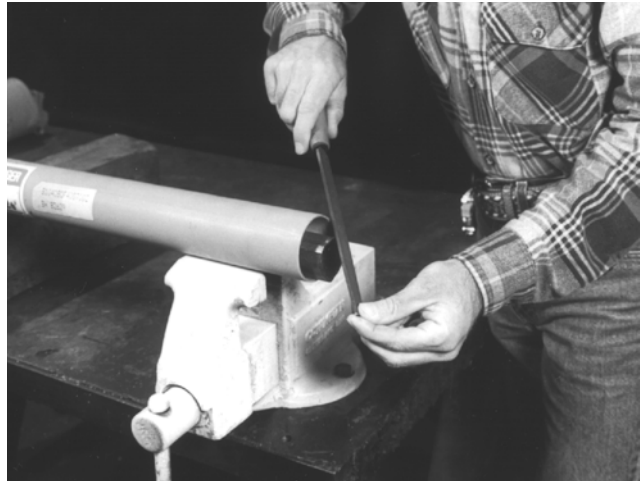

⚠ DANGER

MAKE CERTAIN DRIVELINE YOKES ARE SECURELY FASTENED. FAILURE TO DO SO MAY RESULT IN SERIOUS INJURY.

L. Raise cutter off ground and adjust lower lift arms to level cutter right to left. Refer to tractor operator's manual.

M. Lower cutter to work position. Adjust tractor top link to position cutter top flex link as shown in Figure 2-6. This allows cutter to "float" during operation.

N. Adjust tractor sway chains, stabilizer bar or equivalent to prevent side sway.

Figure 2-6 Flex-Link

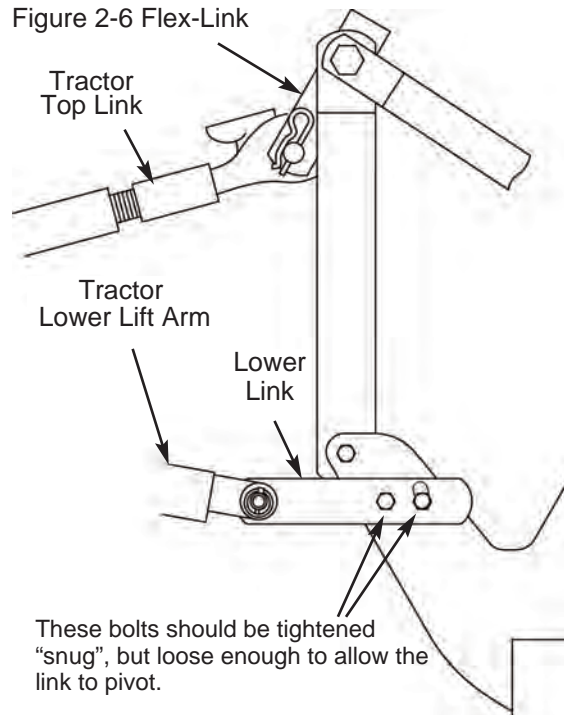

SECTION III OPERATING INSTRUCTIONS

3-1 GENERAL SAFETY

Only qualified people familiar with this operator's manual and tractor operator's manual should operate this machine. Operator should wear hard hat, safety glasses and safety shoes. The operator should read, understand and practice all safety messages shown on the caution, warning and danger decals affixed to the cutter to avoid serious injury or death. Use ROPS (Rollover Protective Structures) and seat belt equipped tractors for mowing operations. Before beginning operation, clear work area of any objects that may be picked up and thrown. Check for ditches, stumps, holes or other obstacles that could upset tractor or damage cutter. Always lower cutter to ground and allow blades to come to a complete stop, set parking brake and turn off tractor engine before leaving tractor operator's seat.

3-2 CUTTING HEIGHT ADJUSTMENT

The cutter should be operated at the highest position that will give desired cutting results. This will help prevent blades from striking the ground, reducing blade wear and undue strain on the machine. Cutting too much material will leave excess clippings on the lawn surface. The more frequently the lawn is mowed, the better the effect will be. Adjust as follows:

A. Raise cutter off ground using tractor 3-point lift. SECURELY BLOCK CUTTER IN POSITION.

⚠ WARNING

THE CUTTER CAN FALL FROM HYDRAULIC SYSTEM FAILURE. TO AVOID SERIOUS INJURY OR DEATH, SECURELY SUPPORT CUTTER BEFORE WORKING UNDERNEATH

B. Remove pin securing caster wheel to bracket. (Figure 3-1) Remove caster wheel from arm.

C. Place amount of spacers on caster wheel to give desired cutting height. With no spacers on the bottom, a 1-1/2" or slightly lower cutting height is given.

D. Reinstall caster wheel into caster arm. Place remaining spacers on caster wheel and install pin to retain.

E. Repeat operation for all caster wheels. Make certain all wheels are adjusted to the same height.

3-3 OPERATION

A. Perform BEFORE EACH USE maintenance list in paragraph 4-1.

B. Start tractor. Lower cutter until it is supported by caster wheels. Position tractor lower lift arms as shown in Figure 2-6, page 9. This will allow cutter to "float" during operation.

Figure 3-1

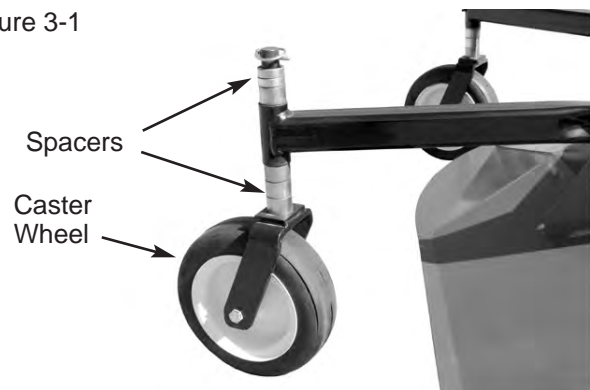

⚠ DANGER

STAY CLEAR OF ROTATING DRIVELINE. DO NOT OPERATE WITHOUT DRIVELINE SHIELDS IN PLACE AND IN GOOD CONDITION. FAILURE TO HEED THESE WARNINGS MAY RESULT IN PERSONAL INJURY OR DEATH.

⚠ DANGER

STAND CLEAR OF ROTATING CUTTER BLADES UNTIL ALL MOTION HAS STOPPED. TO AVOID ACCIDENTAL FALL AND POSSIBLE INJURY FROM CUTTER, USE ROPS (ROLLOVER PROTECTION STRUCTURES) AND SEAT BELT EQUIPPED TRACTORS FOR ALL MOWING OPERATIONS.

C. With tractor at idle speed, engage PTO drive. Advance throttle to 540 PTO rpm.

D. Place tractor in low gear and begin cutting. Tractor forward speed should be controlled by gear selection, not engine speed. For maximum cutting efficiency, forward speed should allow cutter to maintain a constant maximum blade speed.

Cutting height should not put undue strain on tractor and implement drivetrain. If tractor engine or cutter stalls, do not slip tractor clutch to allow engine to retain speed as this will exert undue strain on the implement drivetrain. When stalling occurs, disengage PTO drive, move to a cut area, set tractor throttle to idle, then re-engage PTO drive.

Always cut up and down the face of slopes, never across.

Check belt tension after first 8 hours. Adjust per-paragraph 4-3 if needed.

3-4 TRANSPORTING

Turn off PTO drive and fully raise tractor 3-point lift before transporting. When implement is transported on road or highway, day or night, use tractor flashing warning lights unless prohibited by law. A slow moving vehicle (SMV) sign on the tractor must be visible from the rear by approaching vehicles.

SECTION IV MAINTENANCE

4-1 MAINTENANCE CHECK LIST

Perform scheduled maintenance as outlined below. Lower implement to ground, turn off tractor, and set parking brake before doing maintenance inspections or work. Some checks may require raising machine off ground and supporting with blocks. All bolts should be torqued as indicated in torque chart unless otherwise indicated.

WARNING

THE CUTTER CAN FALL FROM HYDRAULIC SYSTEM FAILURE. TO AVOID SERIOUS INJURY OR DEATH, SECURELY SUPPORT CUTTER BEFORE WORKING UNDERNEATH.

BEFORE EACH USE.

1. Check tractor tire air pressure. Refer to tractor operator's manual. **Check mower tire pressure (if pneumatic tires). Tire pressure should be 30 psi.**
2. Check blades and spindles to be sure that no foreign objects such as wire or steel strapping bands are wrapped around them.
3. Check blade bolts for tightness. **Tighten blade bolts to 76 ft./lbs.**
4. Inspect blades for wear. Replace if necessary per paragraph 4-5. Use only genuine Bush Hog replacement parts. If it is necessary to sharpen the blades, remove the blades from the spindles before sharpening. **DO NOT sharpen blades while still attached to mower.**
5. Make certain all shields are in place and in good condition. Repair or replace any missing or damaged shields.
6. Inspect wheel(s) for wear, damage or foreign objects. Repair or replace if necessary.
7. Perform BEFORE EACH USE lubrication per paragraph 4-2.

Figure 4-1A

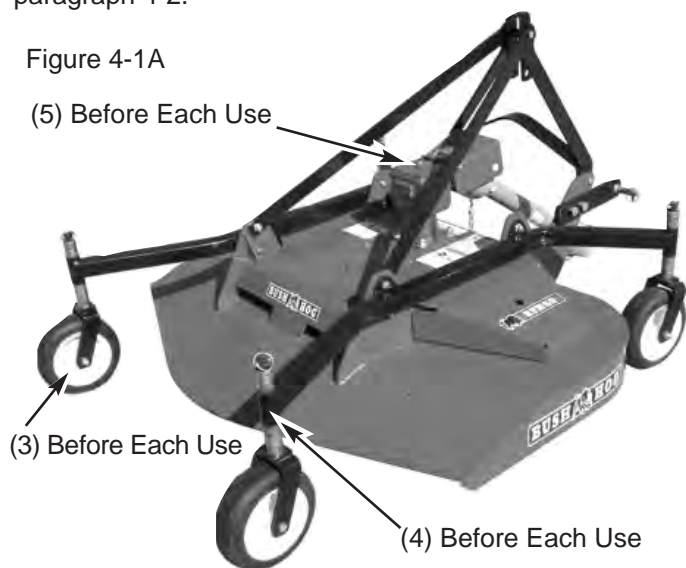

8. During operation, listen for abnormal sounds which might indicate loose parts, damaged bearings, or other damage. Correct any deficiency before continuing operation.

AFTER EACH USE

1. Clean all debris from machine especially underside of deck, underneath belt shield and off safety decals. Replace any missing or illegible decals.
2. Inspect cutter for worn or damaged components. Repair or replace before next use. Any replacement components installed during repair shall include the components' current safety decals specified by the manufacturer to be affixed to the component.
3. Store cutter in a dry place.

40 HOURS

1. Check belt for proper tension. Refer to paragraph 4-3.

4-2 LUBRICATION (Figures 4-1A, & B)

NOTE

The multi-purpose grease referenced in this section is an NLGI Grade 2 type grease.

BEFORE EACH USE

1. Driveline Universal Joints - Apply multi-purpose grease with grease gun.
2. Driveline Guard - Apply 2-3 shots of multi-purpose grease with grease gun to plastic fitting.
3. Wheels - Apply multi-purpose grease with grease gun.
4. Caster Pivot - Apply multi-purpose grease with grease gun.
5. **Input Gearbox - Add EP80W-90 gear oil, if necessary, to bring oil level to check plug.**

20 HOURS

6. Driveline - Disconnect PTO driveline, pull the two sections apart, thoroughly clean old grease from tubes and apply thin coat of multi-purpose grease to outside of inner (male) section. Reassemble sections and install. Pull each section to be sure driveline and shields are securely connected. Make certain PTO shielding is in good condition.

Figure 4-1B

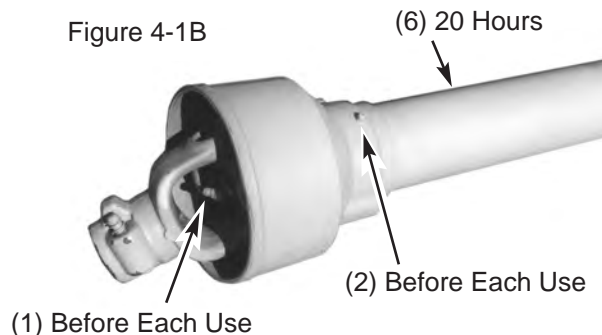

40 HOURS

7. Spindle Assembly - Apply 3 shots of multi-purpose grease with grease gun every 40 hours. Grease fittings for spindles are accessible through holes in the shields.

4-3 BELT ADJUSTMENT

Belt tensions should be checked every 40 hours to get maximum life from drive belts and best performance from the cutter. Belt tension is adjusted by

Figure 4-2 5/16" Hex Nuts - Spring Length Adjustment

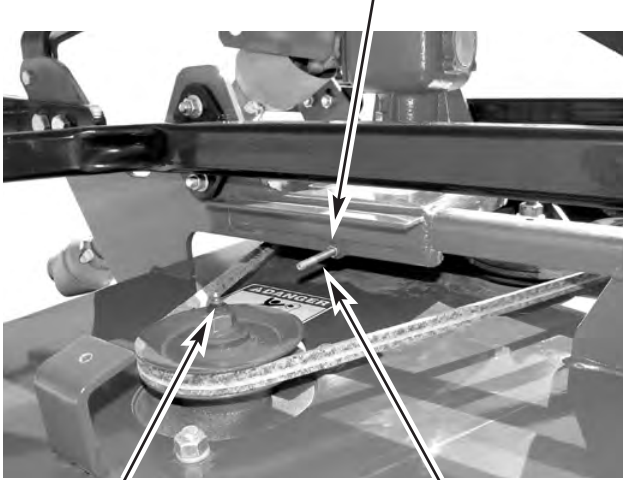

(7) 40 Hours Rod Extends 1-13/16" From Frame

increasing or decreasing the length of the spring on the moveable idler. For proper belt tension on the mower, the spring length should be 6-3/4" (Figures 4-2 & 4-3) To adjust the spring length, loosen or tighten the 5/16" hex nut on the spring adjustment rod until the correct spring length is reached.

4-4 BELT REPLACEMENT

Use only genuine Bush Hog replacement parts.

- A. Remove right and left side shields.
- B. Relieve spring tension by loosening the 5/16" hex nut on the spring adjustment rod. (Figure 4-3)
- C. Remove old belt.
- D. Install new belt as shown below. (Also refer to the decal on underside of belt shield) Be sure that the belt is properly positioned in all sheave grooves.
- E. Adjust tension on the belt by adjusting the length of the spring on the moveable idler. The correct initial rod length is 1-13/16".
- F. Replace all shields before operating machine.

Figure 4-3
RFM 60 BELT DIAGRAM

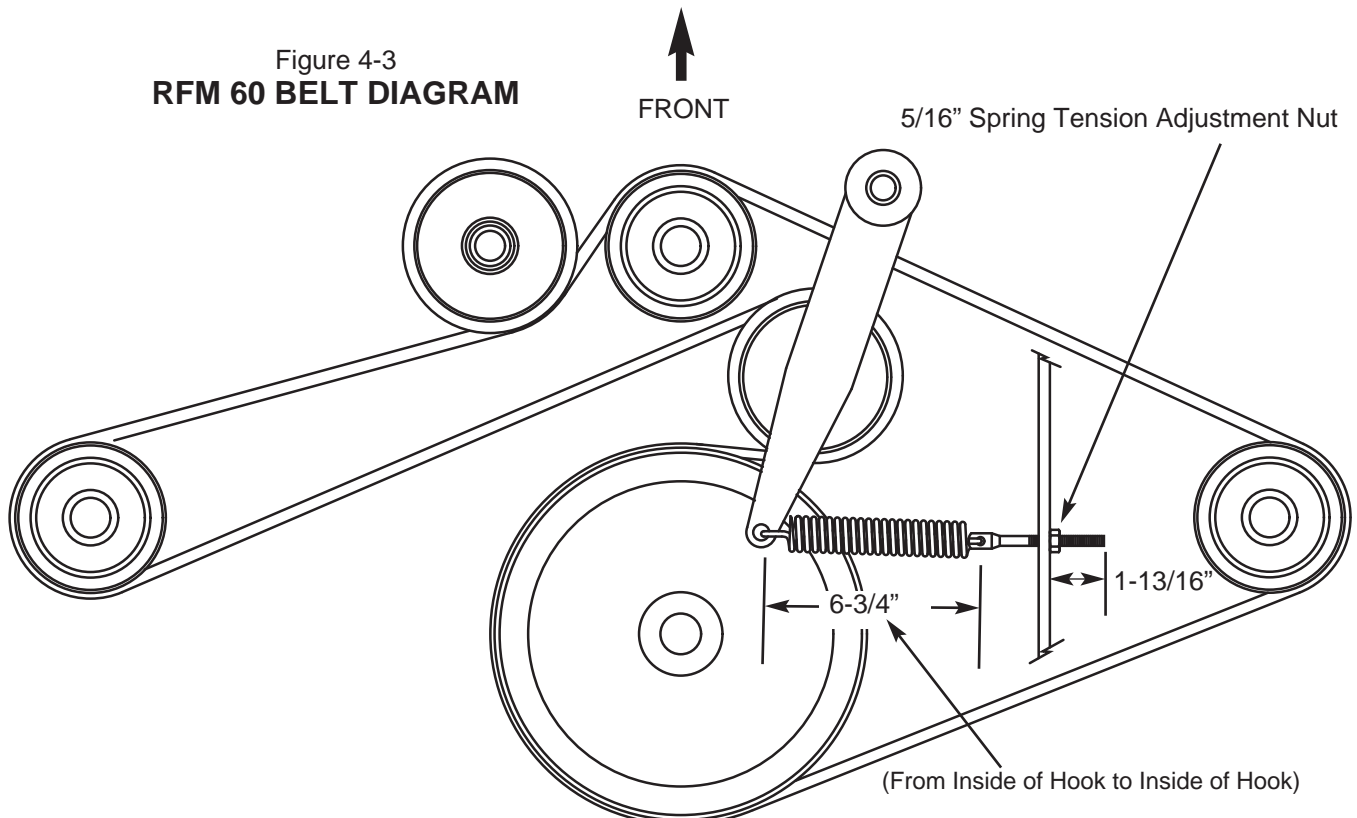

4-5 BLADE REPLACEMENT



CAUTION
WEAR HEAVY WORK GLOVES TO PROTECT HANDS FROM SHARP EDGES.

- A. Raise cutter using tractor 3-point lift and SECURELY BLOCK INTO POSITION.
- B. Turn off tractor, set parking brake and remove key.
- C. Remove bolt and cup washer securing blade to spindle. Remove blade.
- D. Install new blade as shown in Figure 4-4 with concave side of cup washer against blade. Be sure that blades are installed with offset in proper direction. **Tighten retaining bolt to 76 ft./lbs.**

Figure 4-4 Blade Placement

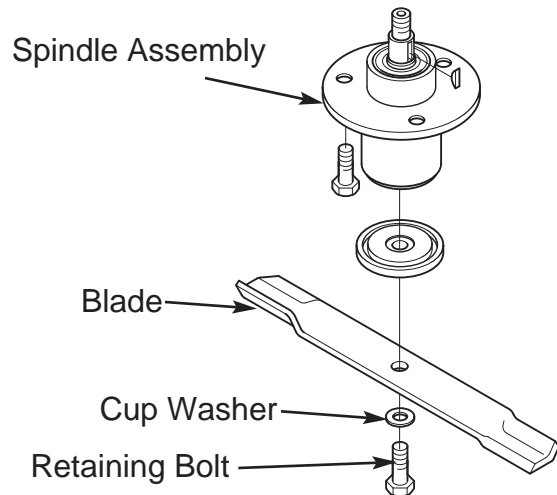

4-6 TROUBLESHOOTING

Troubleshooting procedures are listed in Table 4-1 below. If the problem cannot be solved or replacement parts are necessary, contact your authorized Bush Hog dealer. Please have ready your machine name, model number, serial number, purchase date and exact cause or description of problem.

Table 4-1 Troubleshooting

PROBLEM	PROBABLE CAUSE	REMEDY
Uneven Cut	Cutter not level side to side or front to rear.	See SECTION III.
	Belt slipping.	Adjust belt per paragraph 4-3.
	Worn or bent blade(s).	Replace blade(s).
Streaking or Windrowing	Possible build-up of material under cutter.	Clean cutter.
	Cutter not level.	See SECTION III.
	Worn blades.	Replace blades.
	Belt slipping.	Adjust belt per paragraph 4-3.
Noisy Cutter	Loose components.	Check all bolts for tightness.
	Low oil in gearbox.	Check oil per paragraph 4-2.
Rapid Blade Wear (cutting edge)	Blade contacting ground.	Adjust cutting height to eliminate ground contact.
Cutter Vibrating	Cutter not being operated at rated PTO speed.	Set tractor throttle for proper PTO speed.
	Blade(s) bent.	Replace blades.
	Foreign object wrapped around spindle or blade.	Remove object.

SECTION V DEALER ASSEMBLY

CAUTION

THE FOLLOWING SAFETY PRECAUTIONS SHOULD BE THOROUGHLY UNDERSTOOD BEFORE ATTEMPTING MACHINE ASSEMBLY.

1. Wear personal protective equipment such as, but not limited to, protection for eyes, ears, feet, hands, lungs and head when assembling the equipment. Do not wear loose clothing or jewelry that may catch on equipment moving parts.

2. Do not lift heavy parts or assemblies. Use crane, jack, tackle, fork trucks or other mechanical devices.

3. Select an area for assembly that is clean and free of any debris which might cause persons working on the assembly to trip.

4. Arrange parts to be assembled neatly in the work area and have tools or other mechanical assisting devices in easy reach.

5. Inspect all parts and assemblies thoroughly and remove any sharp edges, grease, oil or dirt which might cause pieces to slip when handling.

6. Preview the assembly instructions in your operator's manual before proceeding further.

7. If the assembly instructions call for parts or assemblies to be blocked up, use only blocking material that is in good condition and is capable of handling the weight of the assembly to be blocked. Also, insure that the blocking material is on a clean, dry surface.

8. Never put hands or any other part of body under blocked up assemblies if at all possible.

9. Always wear goggles or safety glasses when hammering, grinding, or drilling metal parts.

10. If the assembly calls for welding or cutting, be sure that there are no flammable materials close at hand and that bystanders have taken necessary precautions.

AFTER COMPLETING ANY ASSEMBLY STEP, THOROUGHLY READ THE NEXT STEP IN THE ASSEMBLY INSTRUCTIONS BEFORE PROCEEDING WITH THAT STEP.

11. After completing assembly, thoroughly inspect the machine to be sure that all nuts, bolts, hydraulic fittings or any other fastened assemblies have been thoroughly tightened.

12. After completing assembly, be sure that all safety locking devices or guards are in place.

13. Before operating the machine, thoroughly read the operation section of this manual.

14. Before operating the machine, read the maintenance section of this manual to be sure that any parts requiring lubrication such as gearboxes are full to avoid any possible damage.

BEFORE OPERATING THE EQUIPMENT, IF YOU HAVE ANY QUESTIONS REGARDING THE PROPER ASSEMBLY OR OPERATION, CONTACT YOUR AUTHORIZED BUSH HOG DEALER OR REPRESENTATIVE.

5-1 BASE UNIT ASSEMBLY (Figure 5-1)

A. Attach lower lift links to deck assembly using $3/4 \times 2$ " bolts and lock nuts. Both bolts should be tightened "snug", but loose enough to allow link to pivot. Slotted holes are provided to allow the mower to more closely follow ground contours. (Figure 5-2)

B. Install lift pins onto lower links, securing with $7/8$ " lockwashers and hex nuts.

C. Attach mast halves to deck assembly using $1/2 \times 1-1/2$ " bolts, lockwashers and hex nuts.

D. On each side of the mower, the mast support will attach to the inside of the rear lug with the same $1/2 \times 1-1/2$ " bolt and flanged lock nut that fastens the caster arm to the outside of that same lug. Use a $1/2 \times 1-1/2$ " bolt and flanged lock nut to fasten the front end of the caster arm to the front mounting lug. Repeat this procedure on the opposite side.

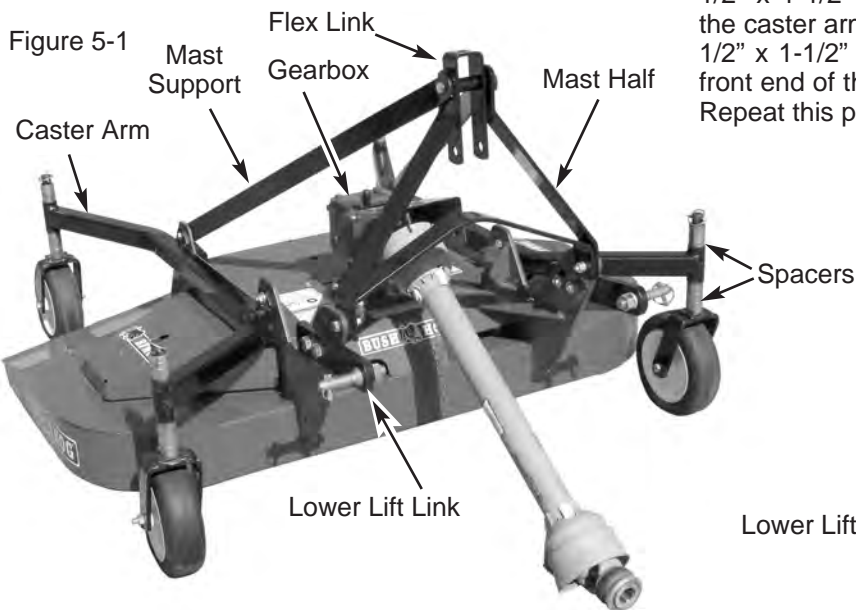
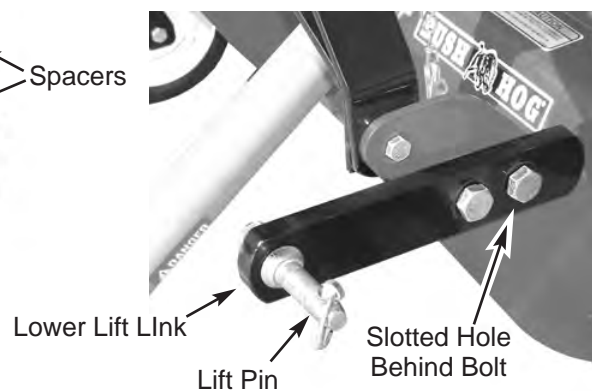

Figure 5-2



E. Fasten mast supports and upper flex link to mast halves using 1/2 x 5" capscrew, pivot tube and locknut.

F. Place two long spacers on the caster stems and insert into caster arms. Place two long spacers and two short spacers on the caster stem above the caster arms. This arrangement will give a cutting height of approximately 3-1/2 inches. Secure with

lynch pin retainers. With weight of cutter resting on all four wheels, ensure that cutter is level. Tighten all bolts on mounting brackets.

G. Fill gearbox with EP80W-90 gear oil until oil level is at check plug on side of gearbox housing. (Capacity is 1 quart) Replace solid fill plug with breather plug supplied in operator's manual package.

RFM 60



SAFETY DECALS

To promote safe operation, Bush Hog supplies safety decals on all products manufactured. Because damage can occur to safety decals either through shipment, use or reconditioning, Bush Hog will, upon request, provide safety decals for any of our products in the field at no charge. Contact your authorized Bush Hog dealer for more information.



50042283



50042282



50042285



78608



50012616



78786



83056



50042284



50042281



50012615

TORQUE SPECIFICATIONS

Proper torque for American fasteners used on Bush Hog equipment.
Recommended Torque in Foot Pounds (Newton Meters).*

AMERICAN Bolt Head Markings

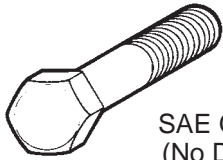

SAE Grade 2
(No Dashes)

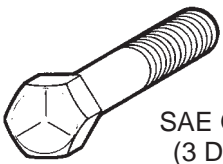

SAE Grade 5
(3 Dashes)

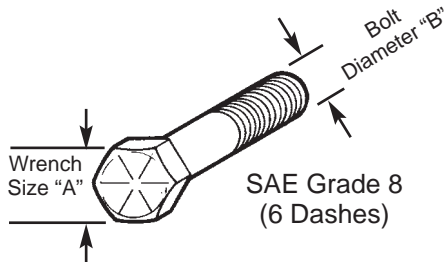

SAE Grade 8
(6 Dashes)

WRENCH SIZE (IN.) "A"	BOLT DIAMETER (IN.) "B" AND THREAD SIZE	SAE GRADE 2	SAE GRADE 5	SAE GRADE 8
7/16	1/4 - 20 UNC	6 (7)	8 (11)	12 (16)
7/16	1/4 - 28 UNF	6 (8)	10 (13)	14 (18)
1/2	5/16 - 18 UNC	11 (15)	17 (23)	25 (33)
1/2	5/16 - 24 UNF	13 (17)	19 (26)	27 (37)
9/16	3/8 - 16 UNC	20 (27)	31 (42)	44 (60)
9/16	3/8 - 24 UNF	23 (31)	35 (47)	49 (66)
5/8	7/16 - 14 UNC	32 (43)	49 (66)	70 (95)
5/8	7/16 - 20 UNF	36 (49)	55 (75)	78 (106)
3/4	1/2 - 13 UNC	49 (66)	76 (103)	106 (144)
3/4	1/2 - 20 UNF	55 (75)	85 (115)	120 (163)
7/8	9/16 - 12 UNC	70 (95)	109 (148)	153 (207)
7/8	9/16 - 18 UNF	79 (107)	122 (165)	172 (233)
15/16	5/8 - 11 UNC	97 (131)	150 (203)	212 (287)
15/16	5/8 - 18 UNF	110 (149)	170 (230)	240 (325)
1-1/8	3/4 - 10 UNC	144 (195)	266 (360)	376 (509)
1-1/8	3/4 - 16 UNF	192 (260)	297 (402)	420 (569)
1-5/16	7/8 - 9 UNC	166 (225)	430 (583)	606 (821)
1-5/16	7/8 - 14 UNF	184 (249)	474 (642)	668 (905)
1-1/2	1 - 8 UNC	250 (339)	644 (873)	909 (1232)
1-1/2	1 - 12 UNF	274 (371)	705 (955)	995 (1348)
1-1/2	1 - 14 UNF	280 (379)	721 (977)	1019 (1381)
1-11/16	1-1/8 - 7 UNC	354 (480)	795 (1077)	1288(1745)
1-11/16	1-1/8 - 12 UNF	397 (538)	890 (1206)	1444 (1957)
1-7/8	1-1/4 - 7 UNC	500 (678)	1120 (1518)	1817 (2462)
1-7/8	1-1/4 - 12 UNF	553 (749)	1241 (1682)	2013 (2728)
2-1/16	1-3/8 - 6 UNC	655 (887)	1470 (1992)	2382 (3228)
2-1/16	1-3/8 - 12 UNF	746 (1011)	1672 (2266)	2712 (3675)
2-1/4	1-1/2 - 6 UNC	870 (1179)	1950 (2642)	3161 (4283)
2-1/4	1-1/2 - 12 UNF	979 (1327)	2194 (2973)	3557 (4820)

METRIC

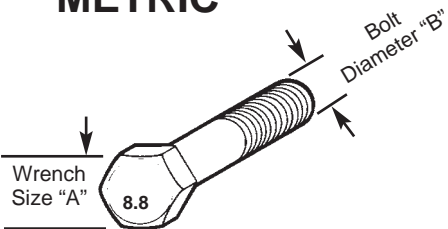

Numbers appearing on bolt heads indicate ASTM class.

Proper torque for metric fasteners used on Bush Hog equipment.
Recommended torque in foot pounds (newton Meters).*

WRENCH SIZE (mm) "A"	BOLT DIA. (mm) "B"	ASTM 4.6	ASTM 8.8	ASTM 9.8	ASTM 10.9
8	5	1.8 (2.4)		5.1 (6.9)	6.5 (8.8)
10	6	3 (4)		8.7 (12)	11.1 (15)
13	8	7.3 (10)		21.1 (29)	27 (37)
16	10	14.5 (20)		42 (57)	53 (72)
18	12	25 (34)	74 (100)	73 (99)	93 (126)
21	14	40 (54)	118 (160)	116 (157)	148 (201)
24	16	62 (84)	167 (226)	181 (245)	230 (312)
30	20	122 (165)	325 (440)		449 (608)
33	22		443 (600)		611 (828)
36	24	211 (286)	563 (763)		778 (1054)
41	27		821 (1112)		1138 (1542)
46	30	418 (566)	1119 (1516)		1547 (2096)

*Use 75% of the specified torque value for plated fasteners. Use 85% of the specified torque values for lubricated fasteners.



2501 Griffin Avenue • Selma, AL 36703
Telephone (334) 874-2700 • www.bushhog.com

Free Manuals Download Website

<http://myh66.com>

<http://usermanuals.us>

<http://www.somanuals.com>

<http://www.4manuals.cc>

<http://www.manual-lib.com>

<http://www.404manual.com>

<http://www.luxmanual.com>

<http://aubethermostatmanual.com>

Golf course search by state

<http://golfingnear.com>

Email search by domain

<http://emailbydomain.com>

Auto manuals search

<http://auto.somanuals.com>

TV manuals search

<http://tv.somanuals.com>