

MAIN OPERATING INSTRUCTIONS



X2-PRO

Digital Solutions

CAMBO

1. INTRODUCTION

Cambo now introduces the new generation technical camera that combines the latest technology of today's digital SLR cameras with full lens shift and tilt possibilities. These instructions give short information about the main functions of this new photographic system.

2. LIST OF FUNCTIONS

- 1. Column Tilt / Lateral Shift
- 2. Knob Lateral Shift
- 3. Knob Tilt
- 4. Lens Plate Housing
- 5. Locking lever Lens Plate
- 6. Lens Plate
- 7. Spirit Level Front Housing
- 8. Front Bracket
- 9. Base Bracket Lens Plate
- 10. Column Swing / Rise & Fall

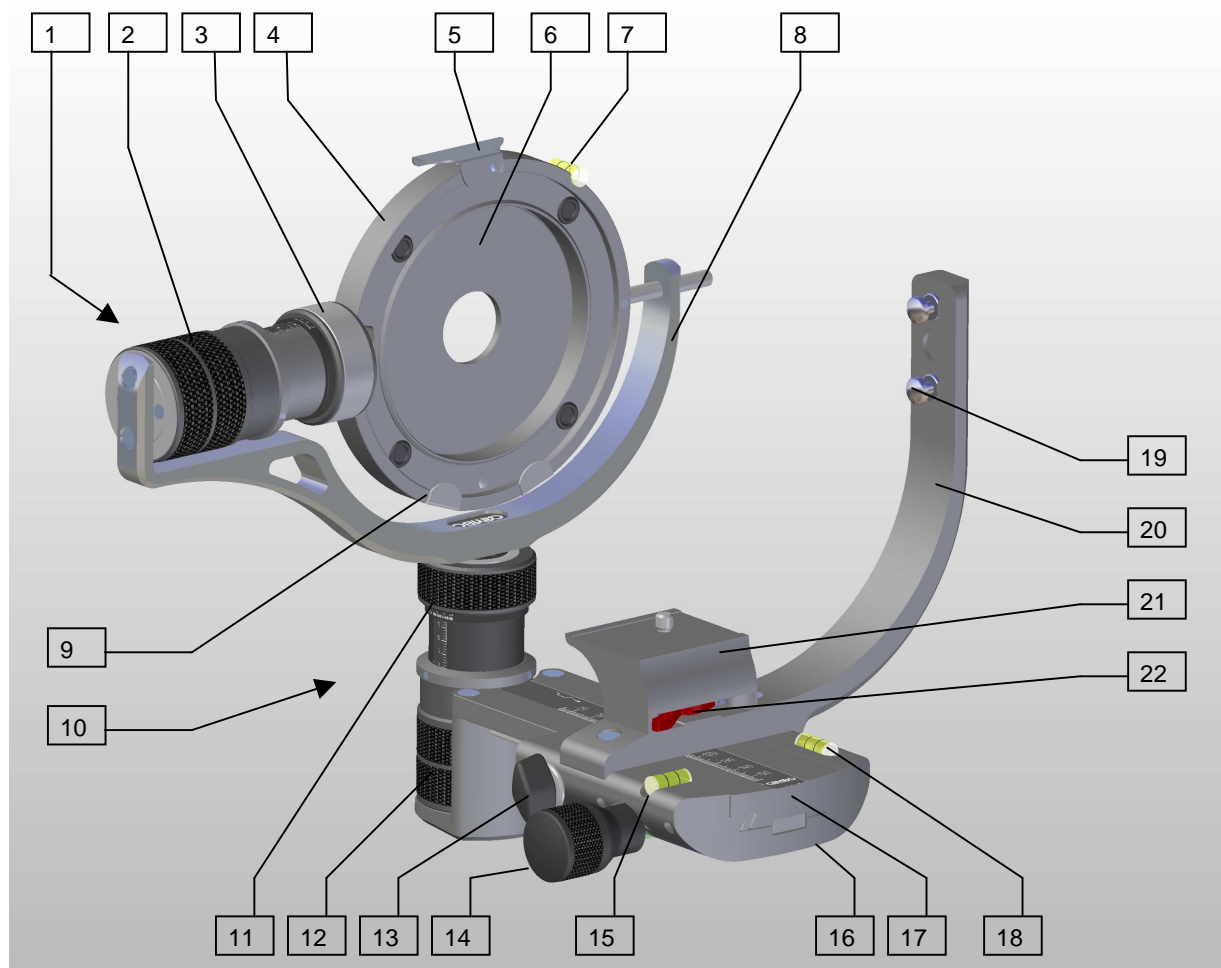

- 11. Knob Swing
- 12. Knob Rise & Fall
- 13. Locking Knob Focus
- 14. Focus Knob
- 15. Spirit level 1 Focus Block
- 16. Focus Block
- 17. Shift Profile
- 18. Spirit level 2 Focus Block
- 19. Pin Mounting Block
- 20. Rear Standard
- 21. Mount Block DSLR Camera
- 22. Lever Mount block clamp

- 23. Safety knob Lever Lens plate
- 24. Bellows
- 25. Scale Swing (Tilt)
- 26. Scale Rise & Fall (Lateral Shift)

- 27. Scale Focus
- 28. Front Ring Bellows (3C)
- 29. ¼" Thumb Screw (3F)

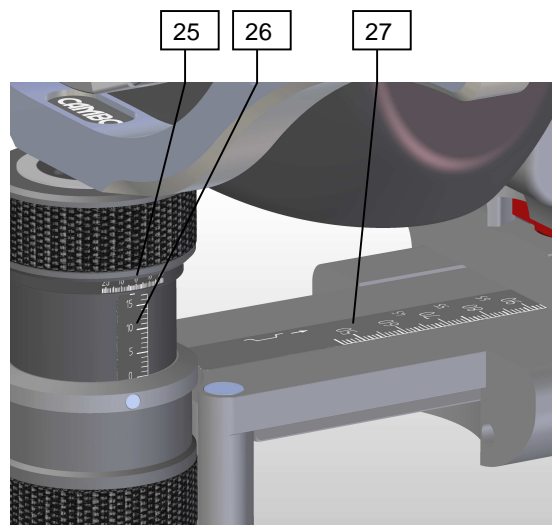
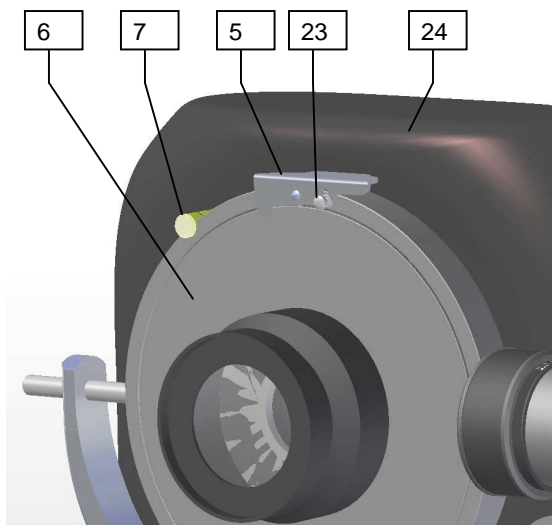

INSTRUCTIONS

These instructions describe the main functions of the X2-PRO camera system. Firstly the set-up of the camera in general is described. Then the possible lenses and interfaces are presented. Finally the way to work with this new camera system is pointed out.

3 Camera Assembly

3A. Checking your parts list

Remove all camera parts from the carton box. To make a complete system make sure that you have one of each of the following:

- X2-PRO Camera Body (is completely assembled)
- Mountblock DSLR camera (see 3B)
- Bellows with bayonet fitting appropriate DSLR camera (see 3B)
- Lens Plate (see 3C)
- Lens (see 3C)
- Your DSLR camera

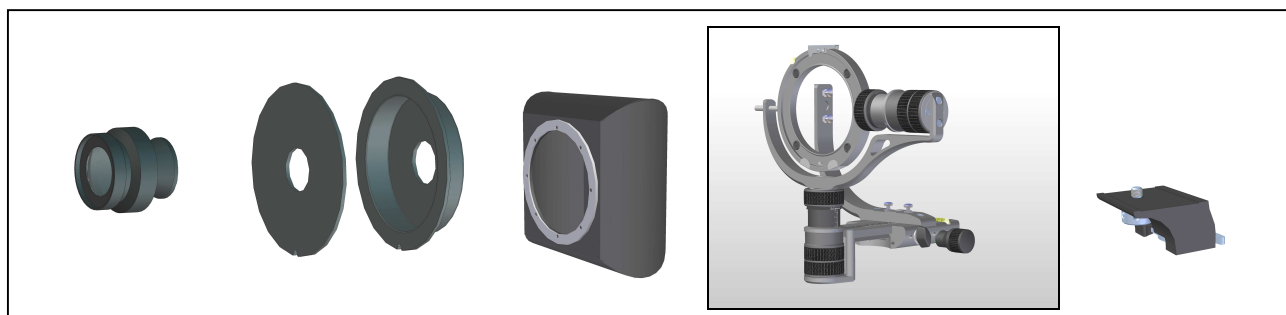

3B. Attaching Camera to Tripod or Stand

To mount the camera, attach the Focus Block (16) to your tripod or stand fitted with a 3/8" mounting thread. (NOTE: Use of a 1/4-20 reducer bushing is not recommended.) Secure tightly. If using a tripod head, level the camera using the spirit levels (15,18) in the Focus Block (16). Unlock the Shift Profile (17) using the Focus locking knob (13) by turning it counter-clockwise. Check if the Shift Profile can be shifted all the way backwards (approximately 63mm on left focus scale (27) reading from behind the camera). If the camera construction touches the tripod or stand, use the 3/8" hole that is closer to the rear of the Focus Block (16).

NOTE: All "right" and "left" references in this instruction guide are made from standing behind the camera.

3C. Attaching the Bellows

Take the bellows and place the bellows front ring (28) behind the Base Bracket (9) of the Lens Plate Housing (4). Push the locking lever (5) at the indicated Bellows "Button". Then push the bellows ring inside the Housing and release the locking lever, locking the ring.

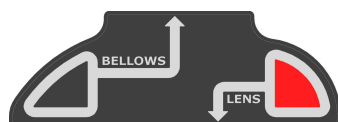

Lens Plate Lever indicator

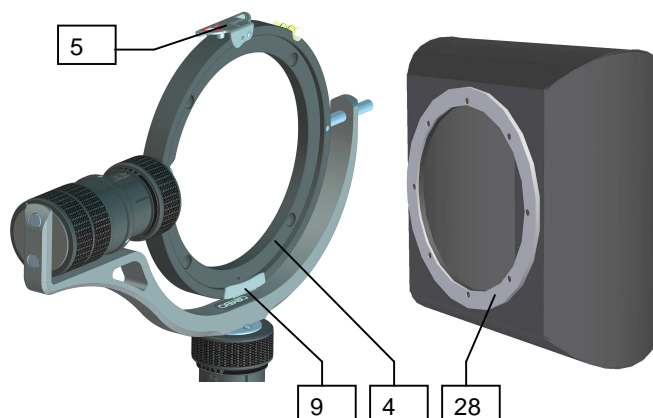

3D. Mounting Lens to Lensboard

Depending on what lens is used, the following methods are used mounting a lens to the Lensboard:

- Hasselblad Lens Adapter: The Lens is placed and locked into the Adapter using the Hasselblad bayonet system. NOTE: This adapter is recessed and therefore it has no locking system on the bayonet construction.
- Mamiya 645pro Lens Adapter: The Lens is placed and locked into the Adapter using the Mamiya bayonet system. Use the instructions with the adapter for the right positioning of the diaphragm ring. NOTE: This adapter is recessed and therefore it has no locking system on the bayonet construction.
- Mamiya RB/RZ Lens Adapter: The Lens is placed and locked into the Adapter using the Mamiya bayonet system. NOTE: This adapter is has no locking system on the bayonet construction.
- Schneider and Rodenstock lenses with "0" size shutter should be mounted directly to the dedicated flat X-223 or recessed X-228 lens panel. The 28,72 and 80mm Schneider ApoDigitars should be mounted in a recessed Lensplate. The 150mm lenses should be mounted on a reversed recessed Lensplate (extending the camera). For macro purposes and the 150mm lenses a macroconverter is available (see 3F)

3E. Mounting Lensboard to Camera

Be sure that the X2-Pro camera is mounted correctly and stable to avoid damaging your lenses / equipment. Take the Lensboard and place it behind the Base Bracket (9) of the Lens Plate Housing (4). Push the safety knob (23) of the locking lever (5) and push the lever at the indicated Lens "button" (5b). Then push the lensboard inside the Housing and release the locking lever. Be sure that the Safety Knob clicks back into the outside position. If necessary push the Lever at the other side till the safety knob clicks. The Lensplate now is locked by the ridge (5a).

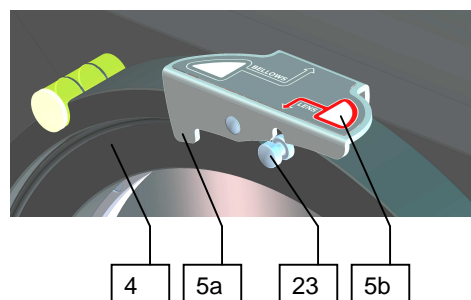

To take off the Lensplate, be sure to hold it with one hand. Then push the safety knob (23) and push the Lever at the indicated Lens "button" (5b).

3F. Mounting DSLR Camera

Take the dedicated Mountblock and mount it under the DSLR camera using the 1/4" Thumbscrew (29). Before tightening it check if the camera is well aligned with the Mountblock.

Be sure that the X2-Pro camera is mounted correctly and stable to avoid damaging your equipment.

Take the DSLR camera with Mountblock and place it on the Pegs (19) of the Rear Standard (20) of the X2-Pro, depending on what orientation is needed for your image set-up. Note that the locking lever (22) should be in the open position (picture shows locked position).

Hold the camera with Mountblock on the Pegs against the Rear Standard and lock the lever. Be sure that the camera is mounted correctly before letting loose.

The camera is demounted again using the reverse order of instructions. Be sure to hold the camera while unlocking the Mountblock lever (22).

For the use of **macro photography** or in combination with the 120 and 150mm lenses a macro converter is available (see picture).

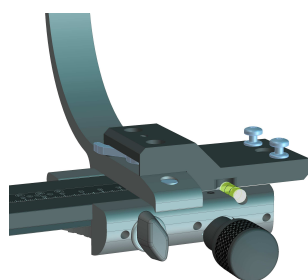
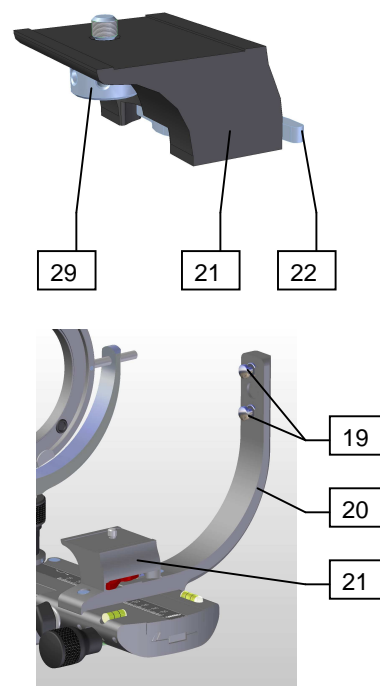

macro converter on X2-Pro

In case of using the converter it is recommended to mount the converter to the X2-Pro before fixing the DSLR camera with Mountblock to the converter again.

Note that the locking lever of the macro converter is situated at the front side of the Rear standard.

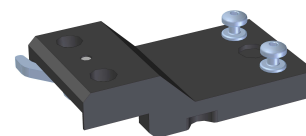

macro converter

4 Camera Functions

After assembling the camera parts, Lensplate and DSLR camera your X2-Pro camera system is ready to be used. In the following instructions the main camera movements and features are described.

4A. Focusing

The Shift Profile makes a linear movement perpendicular to the chip surface. It is manually driven by the Focus Knob (14) and locked if necessary by the locking knob behind (13).

The Profile contains a rough focussing scale that gives an indication of the 'infinity'-position of the lens that is used. The special marks for use of the Hasselblad and Mamiya lenses help you to quickly find the right focusing position for the lens itself.

The right scale with the ballooned 70, 80 and 90 mm indications is based on the use of the recessed Lensplate.

Using the macro converter accessory makes the scale go 70 further than indicated.

4B. Front Standard Movements

The front standard contains horizontal and vertical shift and the tilt and swing movements for the Lens Panel. In the vertical Column (10) the Knob for the Rise & Fall is situated at the bottom (12) with a stroke of 18mm up and down. Every 5mm you can feel an indent. The scale for the Rise & Fall (26) also contains the zero-indication for the Swing scale (25). The Swing Knob (11) gives you a rotation of 20 degrees both ways with an indent for every 5 degrees.

The second column (1) is used for the Lateral Shift and tilt movements. The Shift Knob (2) gives 18mm left and right and the tilt range is like the swing 20 degrees both ways using the Tilt Knob (3).

In the following overview of the "Basic View Camera Movements" the use of the specific movements are explained.

Basic View Camera Movements X2-Pro

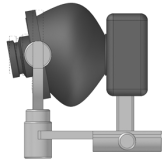

Tilt: Rotating (tilting) the front of the camera left or right.

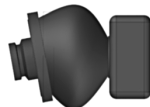

top view

Swing: Rotating (swinging) the front of the camera left or right.

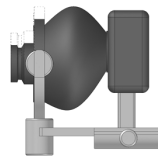

Rise and Fall: Vertically raising or lowering the front of the camera.



top view

Lateral Shift: Moving the front of the camera laterally to the left or right

Vertical Perspective Control (Low Camera Angle)

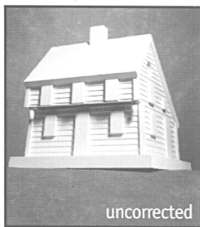

If the camera is pointing upward, and the subject looks like this on the groundglass (converting vertical lines).

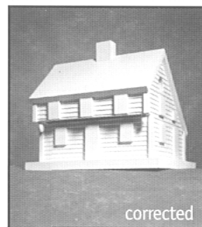

1. Tilt the camera backward to the horizontal position to correct the perspective.
2. Shift the camera front panel upwards to position the subject in the right position and refocus if necessary.



Vertical Perspective Control (High Camera Angle)

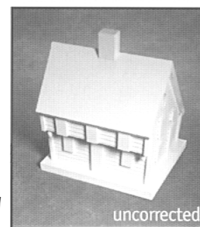

If the camera is pointing downward, and the subject looks like this on the ground glass....

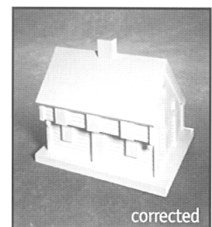

1. Tilt the camera backwards to the horizontal position to correct the perspective.
2. Shift the camera front panel downwards to position the subject to the right position and refocus if necessary.



Horizontal Perspective Control

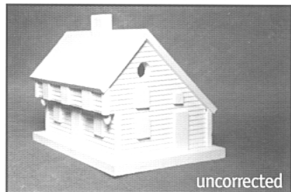

If the camera is pointing at a slight angle to the subject (top view), and the subject looks like this on the ground glass (converging horizontal lines)

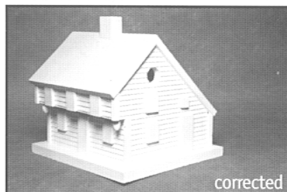

1. Swing camera backwards parallel to the face of the subject to correct perspective.
2. Shift camera front panel to position subject to the right position and refocus if necessary.



Vertical Image Placement

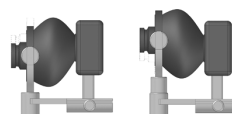
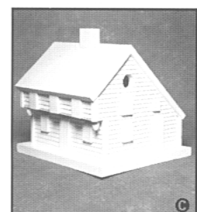
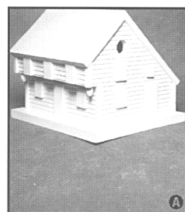

If the subject looks like "A" on the groundglass, or like "B", use the front rise & fall and the subject will look like "C", properly composed. Note: Applying rise on the front panel changes the point of view of the camera. It can make it possible to bring the top of a building into view and keep vertical lines parallel.

Horizontal Image Placement

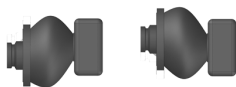
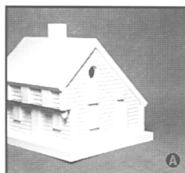

top view

If the subject looks like "A" on the ground glass, or like "B", use the front lateral shift, and the subject will look like "C", properly composed. Note: Using shift on the front panel or lens will change the camera's point of view in relation to the subject. It affects the relationship between near and far subjects.

Plane of Focus

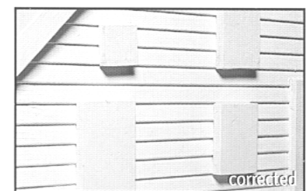
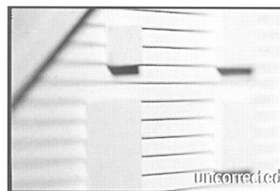

top view

A primary benefit of the view camera is its ability to tilt or swing the plane of the lens to match that of the plane of sharp focus within a scene - without changing the shape of the subject. This also allows the photographer to bring a subject into focus without changing the aperture. Above, the subject was brought into full, sharp focus by swinging the lens until the two were parallel.

5. SPECIFICATIONS

Body specifications:

- **Weight** (body only): 1.9 kg incl. Bellows and mount-block: 2,1kg
- **Size** (hxbxd): 26,3 x 29,3 x 19,5 cm.
- **Front Panel geared movements:**
 - Horizontal Shift:** 17,5mm left, 17,5mm right
 - Vertical Shift:** 17,5mm up, 17,5mm down
 - Tilt angle:** 20° up, 20° down
 - Swing angle:** 20° left, 20° right
- **Focussing range:** 63 to 150mm (global focal length without recessed lensplate)

Note that the possible amount of Lens panel movement is depending on:

- the image circle of the used lens
- the chip size
- the body / bayonet construction of the dslr camera

Lenses:

The X2-PRO camera is suitable for use with Schneider ApoDigitars 28, 72, 80, 90, 100, 120 and 150; for the Rodenstock ApoSironar Digital 90, 105, 135 and 150.

The body is also useable in combination with the following lens adapters:

- Hasselblad CF lens adapter for use of Hasselblad CF lenses
- Mamiya 645Pro lens adapter for use of Mamiya 645 Pro lenses
- Mamiya RB/RZ lens adapter for use of Mamiya RB or RZ lenses.

For other lens solutions contact your Cambo dealer.

DSLR camera compatibility:

The X2-PRO system is introduced with mount-blocks for the following camera bodies:

Canon 1D series and 5D, Nikon D2x and D200, Fuji S3 and Mamiya ZD.

Other mounts will follow, as new DSLR bodies will be introduced.

Spirit levels, Camera demo base.

The spirit levels are of a high quality and used in two directions to level the focusing block. The Lens panel housing has a level for exact horizontal positioning of the lens.

For Cabinet presentation a demo support for the X2-PRO is available.

Accessories:

For more possibilities and accessories please contact your Cambo Dealer.

Cambo R&D

September 2006

This Specification-sheet is prepared by Cambo with care, although no responsibility, financial or otherwise, is accepted for any consequences arising out of the use of this manual or this material. All specifications in this manual are subject to change without notice.

CAMBO Fotografische Industrie B.V.

P.O. Box 200 8260 AE
Haatlanderdijk 45 8263 AP
Kampen, The Netherlands
Telephone: +31(0)38-3314644

Telefax: +31(0)38-3315110
Email: info @cambo.com
Cambo site: www.cambo.com

Free Manuals Download Website

<http://myh66.com>

<http://usermanuals.us>

<http://www.somanuals.com>

<http://www.4manuals.cc>

<http://www.manual-lib.com>

<http://www.404manual.com>

<http://www.luxmanual.com>

<http://aubethermostatmanual.com>

Golf course search by state

<http://golfingnear.com>

Email search by domain

<http://emailbydomain.com>

Auto manuals search

<http://auto.somanuals.com>

TV manuals search

<http://tv.somanuals.com>