



**CAUTION:**  
**READ THIS MANUAL CAREFULLY**  
**BEFORE OPERATING YOUR NEW CANNON®**  
**DOWNRIGGER.**  
**RETAIN FOR FUTURE REFERENCE.**



## MAG 20DT/HS



## MAG 20DT/TS

**NOTE:** Do not return your CANNON® Downrigger to your retailer. Your retailer is not authorized to repair or replace this unit. You may obtain service by:

- calling CANNON® at 1-800-227-6433;
- returning your downrigger to the Factory Service Center;
- sending or taking your downrigger to any CANNON® Authorized Service Center on enclosed list.

**Please include proof of purchase, serial number and purchase date for warranty service with any of the above options.**

## OWNER'S MANUAL

Introduction to Downriggers _____	pg. 2	The Short Stop System _____	pg. 14
MAG 20 DT New Features _____	pg. 3	Positive Ion Control _____	pg. 14
Mounting Your Downrigger _____	pg. 4-7	The Effects of Blowback _____	pg. 16
Terminator & Line Release _____	pg. 8	Troubleshooting _____	pg. 17
Cannon Uni-Release _____	pg. 8	Maintaining Your Downrigger _____	pg. 17
Attaching the Rod Holder _____	pg. 9	Trolling Tips _____	pg. 18
Wiring Your Downrigger _____	pg. 10	Warranty Information _____	pg. 19
Powering Multiple Downriggers _____	pg. 11	Cannon Service Policy _____	pg. 19
Operating Your Downrigger _____	pg. 12	Authorized Service Centers _____	pg. 20

## Introduction to Controlled Depth Fishing

Undoubtedly there are many fishermen familiar with the methods and use of controlled depth fishing. During the mid 1960's the state of Michigan introduced Pacific salmon into the Great lakes in an attempt to revitalize its sport fishing industry. From this successful transplant, new fishing techniques and equipment were developed. One such method was controlled depth fishing which enabled fishermen to place a lure at a desired depth by utilizing downriggers.

Because of the varying factors (water temperature, thermocline, weather, tides, time of day, or time of year) it is necessary for successful fishing to maintain specific water depths that coincide with fish movements and feeding patterns.

One essential feature of the downrigger is the depth meter or gauge that indicates lure depth. This allows the angler to control as well as return to specific depths where fish have been caught.

Due to the success of controlled depth fishing, downriggers are now being used throughout the world to catch a wide variety of species in both fresh and salt water. Whether fishing for blues off Rhode Island, walleyes in Lake Erie, sailfish off the coast of Florida, or stripers in Tennessee, the use of downriggers will make your fishing more successful and more enjoyable.

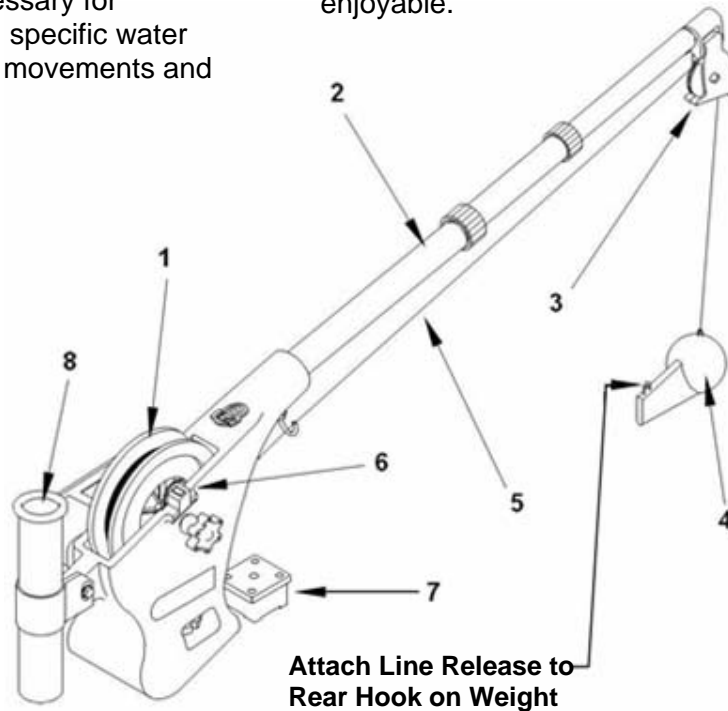

### Parts Description

1. **Reel** This is used to spool the cable, available in lengths ranging from 150 to 400 feet.
2. **Boom** This is used to extend the weight out from the body of the downrigger and has a pulley fixed to its end. Boom lengths range from 24 to 53 inches.
3. **Swivel Head** This relays the cable at the end of the boom to lower the weight.
4. **Weight** This is used to maintain the depth at which you want to fish. Sizes of weights range from 4 to 20 lbs.
5. **Cable** This connects to the weight. Cable material is 150 lb. test stainless steel cable.
6. **Depth Meter** This determines how much cable you have run out, enabling you to choose your trolling depth.
7. **Mounting Base** This attaches to the boat, enabling you to place the downrigger where you choose.
8. **Rod Holder** This holds your fishing rods while trolling and may also be used for storing rods.

## Mag 20 DT New Features

### Magnum Power

The Mag 20 DT/HS and Mag 20 DT/TS feature improved trolling weight capacity, retrieval rate, and quality. The Mag 20 DTs can now accommodate trolling weights up to 20lbs. The newly improved Mag 20 DTs also feature a high retrieval rate up to 250 feet per minute.

### Mag 20 DT/TS Features

The Mag 20 DT/TS (Tournament Series) has an improved appearance featuring a sleek metallic-white finish. An extremely durable stainless steel spool allows for you to outfit your downrigger with monofilament or "super line", eliminating the fish-spooking vibration and harmonics of conventional downrigger cables. With a heavy-duty, brushed stainless steel telescopic boom, adjustable rod holder, and an Off-Shore Release included, the Mag 20 DT/TS is designed specifically for tournament level fishing.

### Battery Alarm

The Mag 20 DT will now beep every two seconds if the battery voltage drops below 9 volts.

### Remote Operation with CannonLink

Your Mag 20 DT has the ability to be operated remotely. Utilizing Humminbird Fishing systems featuring CannonLink, you can control up to 6 Mag 20 DT/HSs and/or Mag 20 DT/TSs simultaneously. CannonLink gives you the ability to cycle downriggers up and down, bottom track, change depth, monitor speed and temp\* (with Cannon Speed & Temp Sensor), and adjust Positive Ion Control from your Humminbird Fishing System (Matrix™, 700, and 900 Series).

### CannonLink Details

The Mag 20DTs connect to the Humminbird unit with the #019095 Mag 20 Master Cable. This cable has an eight-pin plug on one end and a five-pin plug on the other. The eight-pin plugs into the fish finder communication port. Additional Mag 20 DTs are connected to each other in a chain with the #019634 Mag 20 Remote Cable. The last downrigger in the chain must be terminated with the #609198 Endcap plug that comes with the Mag 20 Master Cable. This plug completes the loop allowing the fish finder to get depth and mode information from the Mag 20 DTs. Additional information can be found with the Humminbird fish finder.

The details of CannonLink are described in full in your Humminbird owner's manual. Any one or all Mag 20 DTs can perform these features with CannonLink only from Cannon:

- Set PIC voltage in 1/10ths of volts
- Go to depth (feet or meters)
- Adjustable descent and retrieve speeds
- Cycle mode; includes upper depth, lower depth and time at depth
- Bottom-contour following mode, includes wave height, distance above the bottom
- All up (brings all the weights to the surface immediately)
- Park height (allows you to set individual heights to park the ball above the water)
- Disconnect alarm sounds if the remote cable is accidentally unplugged

The Mag 20DTs communicate through an optically isolated NMEA 0183 standard interface. Each unit is both a listener and a talker to the next unit in the chain. The endcap plug sends the last talker's broadcast back to the first listener/talker, which is usually the fish finder. Only two sentence headers are used: the standard NMEA '\$SDDBT' (SONAR Data Depth Below Transducer) for bottom following, and '\$PCMAG' (Proprietary Cannon MAG) for system control. Several features have been included in the remote interface that would allow the electro-mechanical system to be used for other types of applications.

\*Note: The CannonLink system outputs data from only one single Speed & Temp Sensor Fish.

## Downrigger Mounting on Boats

A downrigger should be mounted where ever it is easy to operate and observe. You want to be able to see your fishing rod and to react quickly. So, choosing a good spot to mount your downrigger on your boat is 99% of the job.

Due to the great variety of boats available, mounting your downrigger can be a dilemma. Having proper mounting accessories is essential. Cannon has a complete line of mounting accessories to conveniently mount your downriggers on any boat.

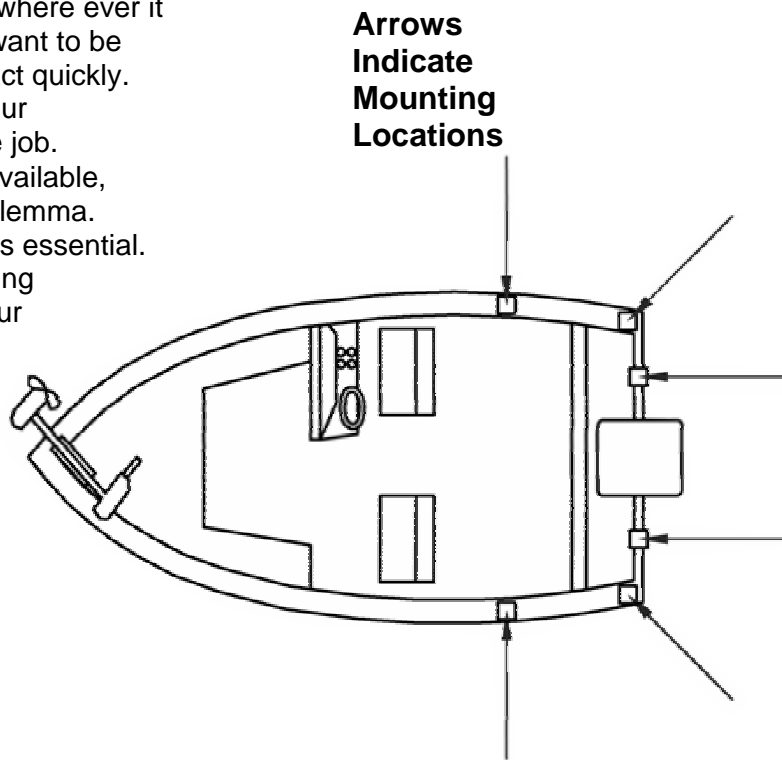

### Mounting Accessories

**Deck Plates** are necessary when extra strength must be added to the base material of the boat and for attaching the downrigger to other mounting accessories.

**Gimbal Mounts** are designed to fit medium-sized flush mounted rod holders built into the gunwale of many larger fishing boats and cruisers. Only sturdy, high quality rod holders should be used for this temporary mounting system. Gimbal mounts are available in 9" or 12" post lengths.

**Clamp Mounts** can be mounted at the junction of two rail sections with the aid of two 1/4" pieces of plywood. They will protect your rail from any marks from the clamp and provide a non-slip surface.

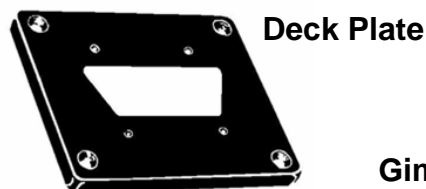

**Gimbal Mount**

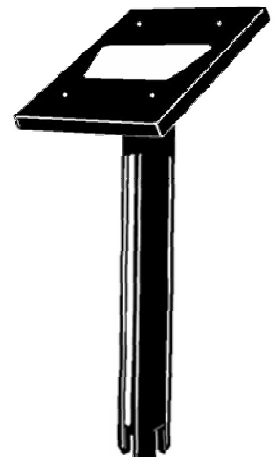

### Side Rail Mounting

Side/Rail mounts can be mounted to a welded T section. They can also be used at the two rail section butt joint. In both installations it is recommended to use a non-slip material, such as rubber or a thin wood sheet, between metal surfaces.

You can also use these for mounting to a very narrow side gunwale. There is a plate provided for back-up with bolts and washers. If the gunwale compartment is foamed in, then wellnuts should be used. It is also recommended to install two additional flat head screws through the top plate for stabilization (you will need to drill and countersink).

**NOTE:** In no case should this mount be used on fiberglass  $\frac{1}{4}$ " thick or less unless it is foamed in.

### Side/Rail on T-Section

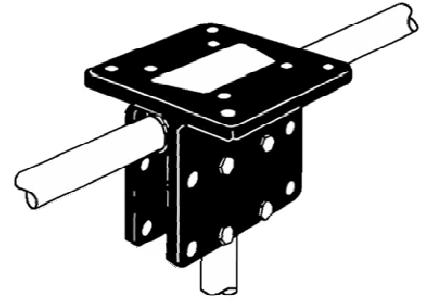

### Side/Rail on Gunwale

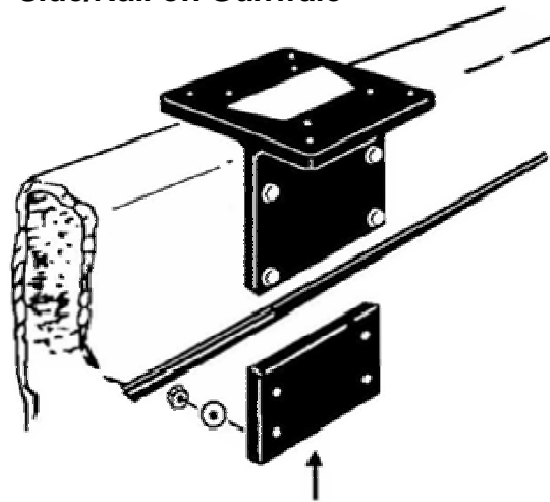

### Pedestal Mounting

Pedestals are used wherever additional height is needed for ease of operation or to clear obstructions, such as handrails.

**Caution:** When using a pedestal mount or side/rail mount, do not extend the telescopic boom on your Mag 20 DT. The increased leverage will cause excessive strain and possible failure of the mount.

### Pedestal for Additional Height

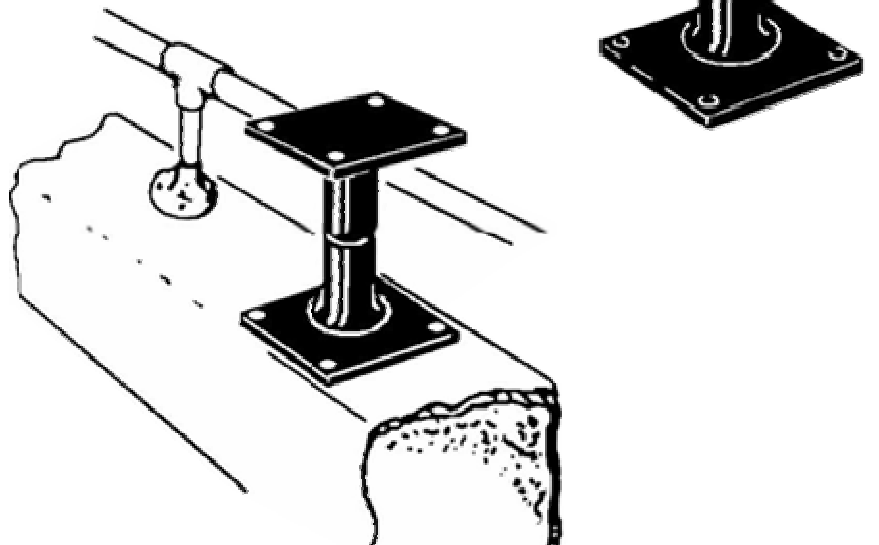

## Installing the Base on Your Boat

### Decks up to 7/16" thick

Where access to the underside of the deck is not available, the mounting base can be mounted using wellnuts. Use the base as a template to mark locations and drill four 1/2" holes. Mount the base using four 1/4-20 x 4" truss head screws and four wellnuts. Tighten the screws so the wellnuts are firmly compressed as pictured.

### Decks thicker than 7/16"

For decks thicker than 7/16", or where the underside of the deck is accessible, mount the base with screws, nuts, and washers. Use the base as a template to mark the locations and drill four 9/32" holes. Use four 1/4-20 x 4" truss head screws and four each flat washers, lock washers, and nuts. Fasten the base to the deck as pictured. **NOTE:** Wellnuts **cannot** be used on decks thicker than 7/16".

### Decks thinner than 1/4"

Use a Cannon deck plate to prevent deflection and add stability to decks thinner than 1/4". Use the deck plate as a template to mark the hole locations.

Decks up to 7/16" Thick

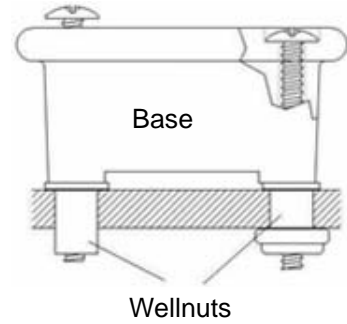

Decks Thicker Than 7/16" Thick

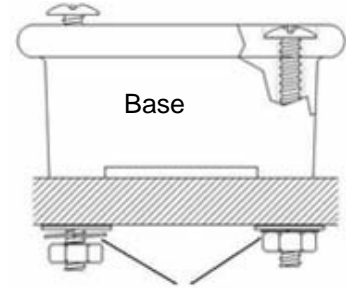

Washer, Lock Washer, and 1/4-20 Hex Nut

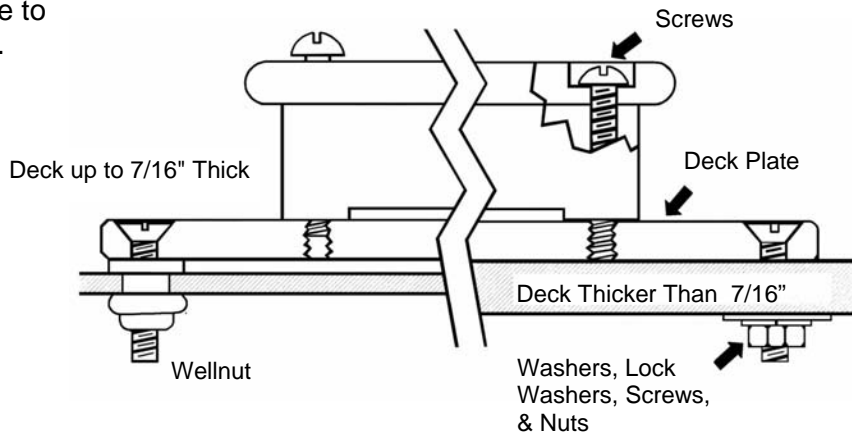

If access to the underside of the deck is not available, the deck plate can be mounted using screws and wellnuts. Drill 1/2" holes. Use four 1/4-20 x 2" flat head screws and four wellnuts to mount deck plate as pictured. Tighten the screws so the wellnuts are firmly compressed.

Where the underside is accessible, the deck plate can be mounted using screws, nuts, and washers. Drill 9/32" holes. Use four 1/4-20 x 2" flat head screws, nuts and washers (flat and lock). Fasten plate to deck as pictured. To secure the mounting base to the deckplate use four 1/4-20 x 2" truss head screws.

**NOTE: When using the telescopic boom, we strongly recommend the use of a deck plate on all boats to provide adequate stability for the downrigger.**

The Low-Profile Swivel Base mounting follows the same procedure as for the deck plate except that four 1/4"-20 x 2 1/2" truss head screws are used to fasten the mounting base and four additional 1/4"-20 x 2 1/2" truss head screws fix the swivel base to the boat deck.

Low-Profile Swivel Base

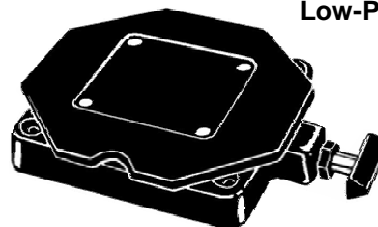

## Mounting the Downrigger on the Base

Slide body over the lip of the base, with boom outboard or facing the stern. Lift Lock Knob to hold threaded shaft clear of base until body completely covers base. Turn Lock Knob clockwise to tighten the downrigger to the base.

**Tip:** Periodically check base to ensure integrity. The base should be replaced at least every 5 years.

## Setting Up Your Downrigger

### Attaching the Boom

#### Telescopic Boom

The intermediate section of the telescopic boom must be extended approximately 5" before the boom locking screw can engage the hole in the boom. Slip the boom end into the frame and align the holes. Secure with boom locking screw.

To adjust boom length, with the boom extending away from you, rotate clamps approximately 1/4 turn counter - clockwise to unlock, and slide boom section to desired position. To lock, rotate clamp clock-wise until tight.

The Standard 24 Inch Boom inserts into the downrigger frame. Be sure that the boom is held securely by seating it firmly against the shoulder inside the frame and fastening the boom locking screw such that it engages the hole in the boom.

#### Assemble Swivel Head To Boom

Insert the telescopic boom-end into the boom-align holes and fasten in place with a #8 x 5/8 screw. Spread the swivel head side plates and slip the assembly over the boom end axle. Snap the assembly together and install two #4 x 1/2" screws into the swivel head.

**TIP:** Adjusting the angle of the boom head can help control cable wrap on the reel.

**TIP:** Whenever downriggers with boom lengths beyond 24" are used, **Cannon's Retro-Ease Weight Retriever** will make bringing in the weight safe and easy. It attaches to the cable below the boom end allowing you to pull the weight to yourself without having to lean way out or collapse the boom to reach the weight.

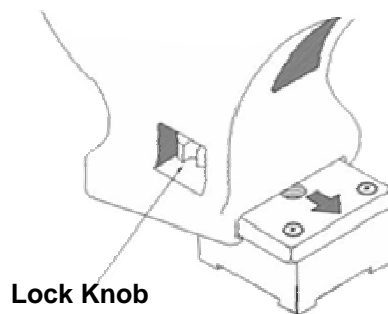

Lock Knob

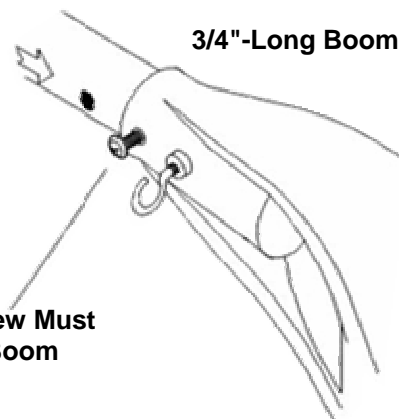

3/4"-Long Boom

The Locking Screw Must Engage Hole in Boom

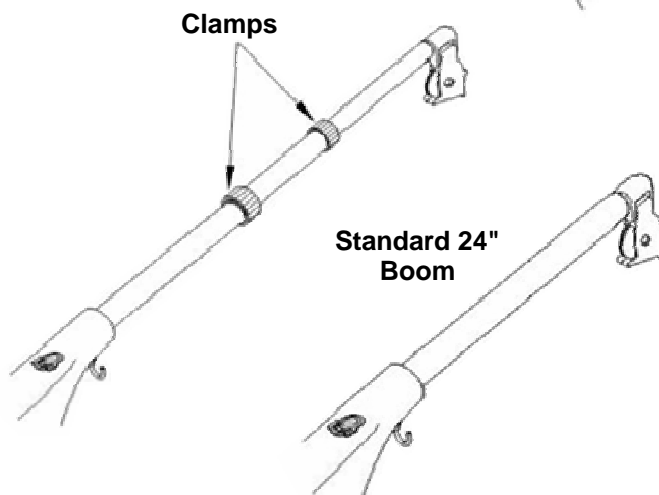

Clamps

Standard 24" Boom

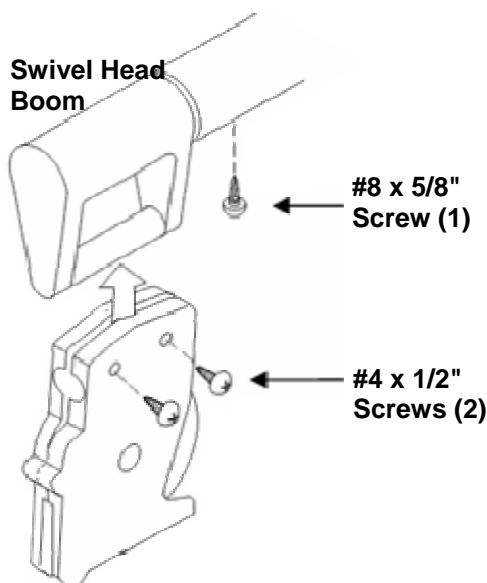

Swivel Head Boom

#8 x 5/8" Screw (1)

#4 x 1/2" Screws (2)

## Terminating the Downrigger Cable

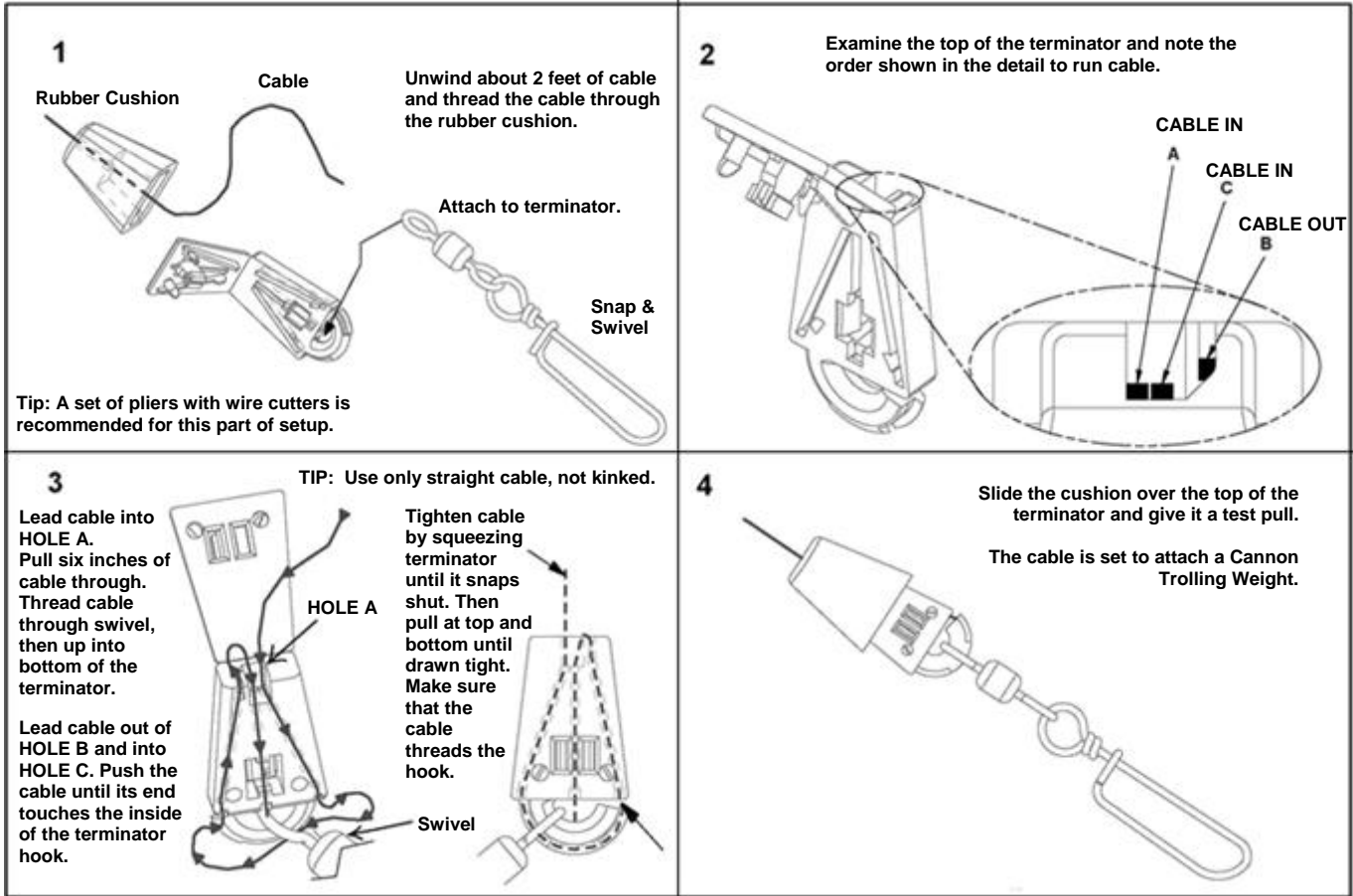

## Cannon Uni-Release

The Cannon Uni-Release attaches directly to the downrigger weight. Attach fishing line to the clip at the end of the release, and then click through a series of increasing tension settings. The release can be used with any test line on salt or fresh water and may be adjusted from 2 to 22 pounds of grip tension on the line.

To change line release tension, turn tension knob to (+) to increase or (-) to decrease. Tension also may vary according to where the line is placed in the grips. Higher tension is on the line if it is set back toward the hinge, and lower if set closer to the opening. To open the release, spread the release arms with thumb and forefinger applying pressure to the sides.

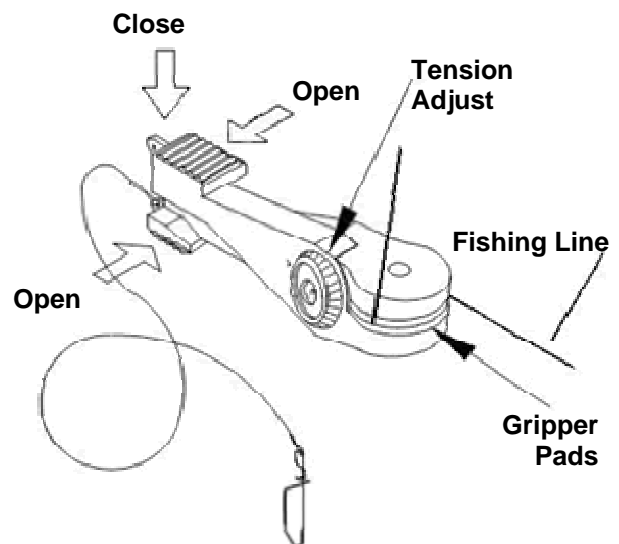



## Attaching the Rod Holder

The positive lock rod holder incorporates a locking disk that allows the rod holder to be aligned in 15 degree increments. Slide the rod holder tube into the clamp to the desired position within the recommended area (see below). Be sure the angled shoulders are facing up. Place the locking disk into the mating recess of the frame. Slip the clamp arms in place where the obround tab on the disk fits into the slot on the clamp. Slide the star washer between the arm of the clamp and the frame. Place the flat washer onto the bolt. Then insert the bolt with washer through the clamp by entering the disk, going through the frame, the star washer, and out the other side of the clamp. Tighten the nut to secure the rod holder. Reposition the rod holder by loosening the nut and adjusting the tilt.

**CAUTION:** This rod holder is intended for use of up to 30 lb. test line only, and is not recommended for use with any tackle IGFA rated higher than 30 lb. A safety strap (not included) is recommended for all applications.

The rod holder assembly is not warranted when used with tackle above 30 lbs.

Equipment placed in the rod holders and the loss thereof is the responsibility of the user and is in no way warranted by JOHNSON OUTDOORS, INC. Mounting must be in accordance with the above instructions and diagram to be warranted.

Single Rod Holder Assembly

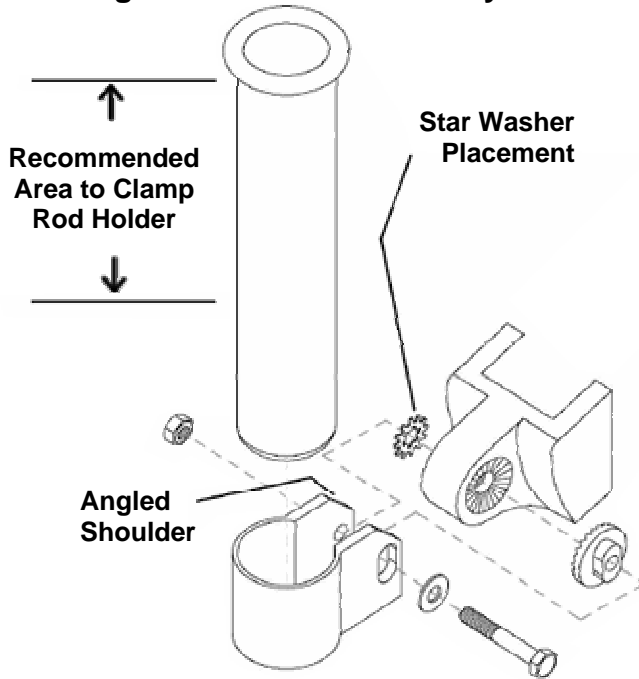

Dual Rod Holder Assembly

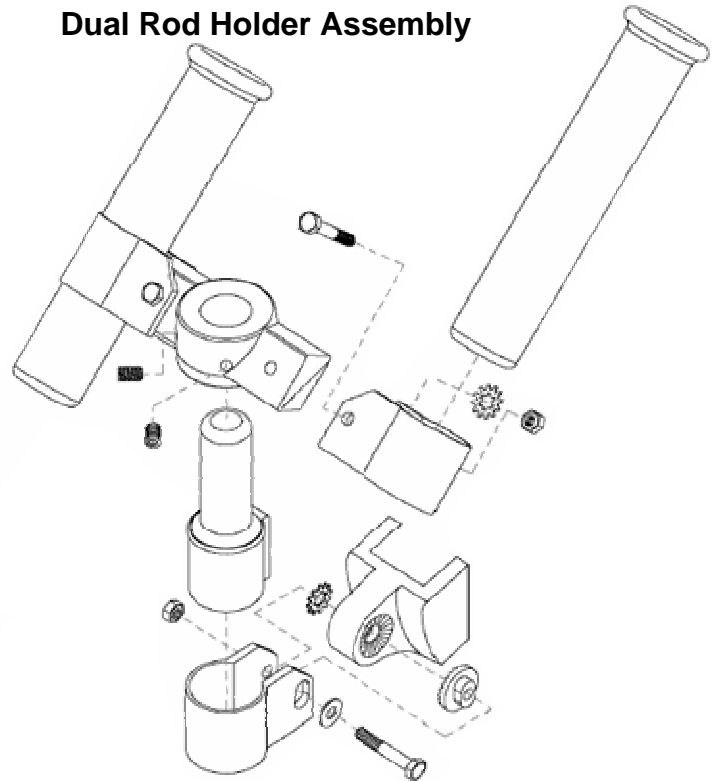

## Wiring Your Downrigger

### Your Boat's Electrical Condition

It is important to make sure that your boat is properly set up before installing your Mag 20 DT with Positive Ion Control (PIC). Whenever a boat is in water, various submerged parts interact to create weak electrical currents. These weak electrical currents must be controlled to extend the life of the boat's metal parts and ensure a good fish catching environment.

Check the zinc sacrificial anodes on your boat and on the outboard/outdrive. If they are more than 50% dissolved they should be replaced. Any coating of slime or growth should be cleaned off. All metal parts including the hull (if metal) must be interconnected by a grounding wire. This includes motor shafts, outdrives, and through hull fittings.

If your boat and zincs are set up correctly, the voltage on the stainless steel downrigger wire of your Mag 20 DT should be positive when in contact with the water. The following tips can be useful:

- Use Cannon vinyl coated lead weights. Lead, if not pure, can produce negative charges.
- Use the trolling weight insulators supplied with your downrigger. This insulates your weight from the positive charge on the cable. This will also ensure that the trolling weight will stop at water level when retrieved.
- The cable on your downrigger should be replaced every 2 years. Etching of the cable can weaken it physically and electrically.
- In saltwater, make sure the sacrificial zincs are replaced when half dissolved. This ensures that the boat will run with a neutral or slightly positive charge. Clean zincs on a regular basis with a non-corrosive brush.
- Always make sure the boat is properly grounded to the water. This will help ensure proper PIC voltage on the cable and that the Short Stop will function properly.

**Note:** You must unplug the Mag 20 DT to check the natural voltage on the reel cable.

### Electrical Specifications & Wiring Instructions

The Mag 20 DT is rated at 25 amps (full load), 12 volts DC and is protected by a 30 amp manual reset circuit breaker (located under motor housing). Be sure to measure the battery voltage of your boat.

**WARNING! - DO NOT RUN THIS DOWNRIGGER ON A 24 VOLT BATTERY SYSTEM. THIS WILL DAMAGE THE UNIT AND VOID YOUR WARRANTY.**

#### Connecting to the Battery:

It is strongly recommended that a fuse or manual-reset circuit breaker be installed at the battery on the positive lead of the power cable or that you connect the downrigger to a battery selector switch. (See Fuse and Wire Specifications) Connect the positive lead (RED) to the (+) post on your battery or the downrigger will not operate. Use the new quick disconnect plug to remove the downrigger without touching the battery.

**NOTE:** It is strongly recommended to power your Mag 20 DT with a Deep-Cycle marine battery. Only run a Mag 20 DT from a Starter battery if is recharged by an alternator while trolling with the outboard motor.

**Tip:** Control degradation of the power cables and limit corrosion by using **Cannon Ox-Not** anti-oxidant gel on all connections.

**FUSE / BREAKER SPECIFICATIONS:**

30 Amp, 32 Volt, waterproof, fast blow.

**WIRE SPECIFICATIONS:**

- 0-15 ft. (0-5 meters) 10 gauge
- 15-25 ft. (5-8 meters) 8 gauge
- 25-30 ft. (8-9 meters) 6 gauge

**CAUTION:** When using wire longer than that provided with your unit, follow the above chart. When running more than 30 feet from the battery, contact a qualified electrician.

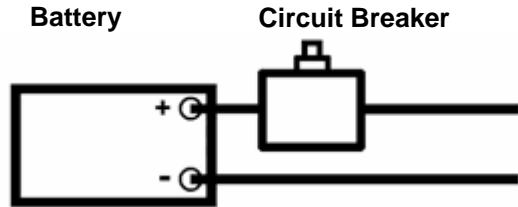
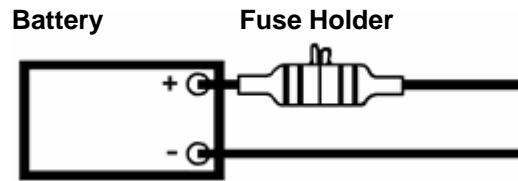

**Powering Multiple Downriggers**

When operating multiple Mag 20 DTs, run a **maximum of 2 downriggers per dedicated battery**. The advanced features of the Mag 20 DT can keep the unit working virtually all the time. (See below for the recommended wiring setup.)

**NOTE:** To ensure proper operation of your Mag 20 DT, ground its battery to your boat's electrical system's ground. Malfunctions with the PIC, communication between units, or loss of operation result from faulty grounding. Always check to see if your boat is properly grounded first.

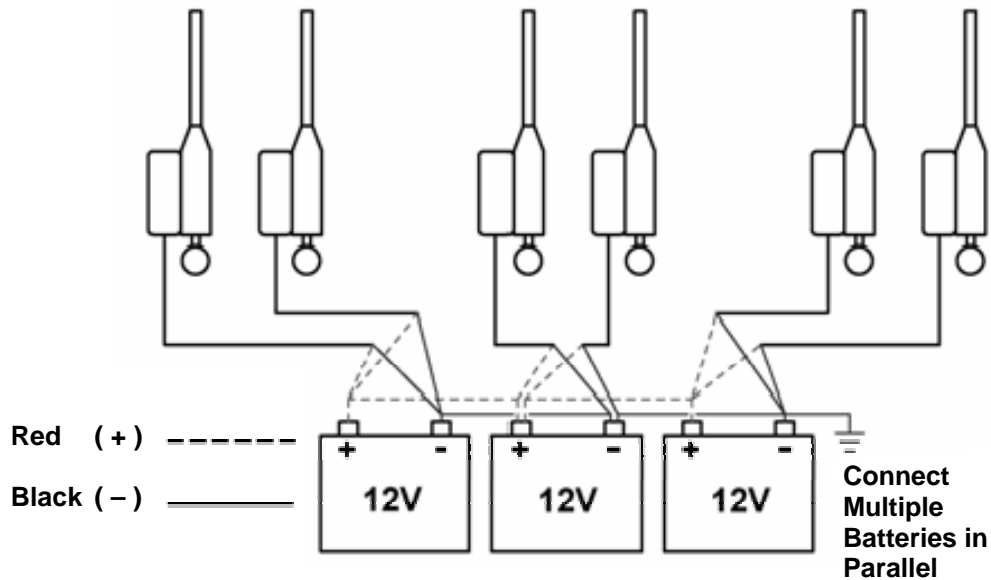

**Typical Operating Time\*:**

- 1 Mag 20 DT per battery – 24 hours.
- 2 Mag 20 DTs per battery – 10 hours.

\*Time based on lab results using a 15lb weight and Deep-Cycle batteries. Actual run time will vary.

**FOR MAXIMUM PERFORMANCE:**

Use Minn Kota Group 27 or 31 sized, Deep-Cycle marine batteries. For extended battery life, add a Minn Kota on-board, DC alternator charger.

## Operating Your Downrigger

After mounting the Cannon downrigger to your boat, release some line from your rod and reel so that the lure is anywhere from 5 to 100 feet behind the boat. This is called drop back.

Attach the fishing line firmly into the line release. Press and hold the toggle switch down to lower the weight to the desired depth as indicated on the depth meter. Place the fishing rod in the rod holder and reel up the slack so that your rod has a slight bend in it. When a fish strikes the lure, the line will separate from the release. Then you will be free to fight the fish and bring it in on your rod and reel.

### Lowering the Weight

The Mag 20 DT can lower the trolling weight manually or powered.

#### Manual Descent: Fast or Slow

By turning the clutch knob gently clockwise (toward the boom), you can let your trolling weight descend as fast or as slowly as you wish. Turning the knob counterclockwise (away from the boom) stops the weight. This gives you control to let it plunge rapidly or sink slowly to a predetermined trolling depth. With multiple downriggers, you could start all your weights creeping down, one at a time, and then stop them each in turn.

#### Powered Descent: One speed fits all

Hold the toggle switch down until the weight reaches the desired depth and release. The motor will stop when switch is released or moved to the neutral position.

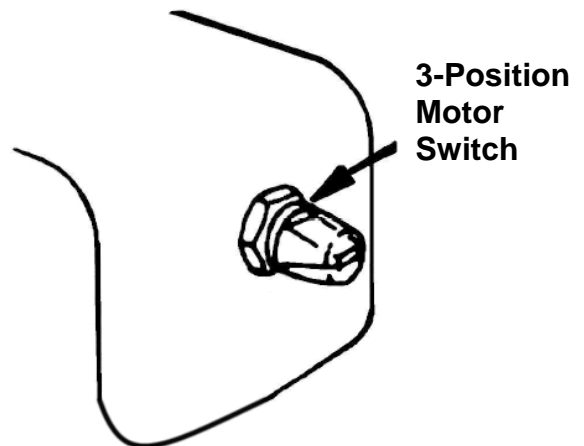
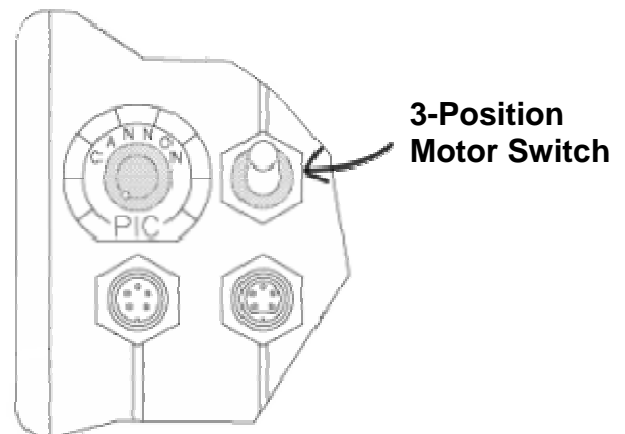
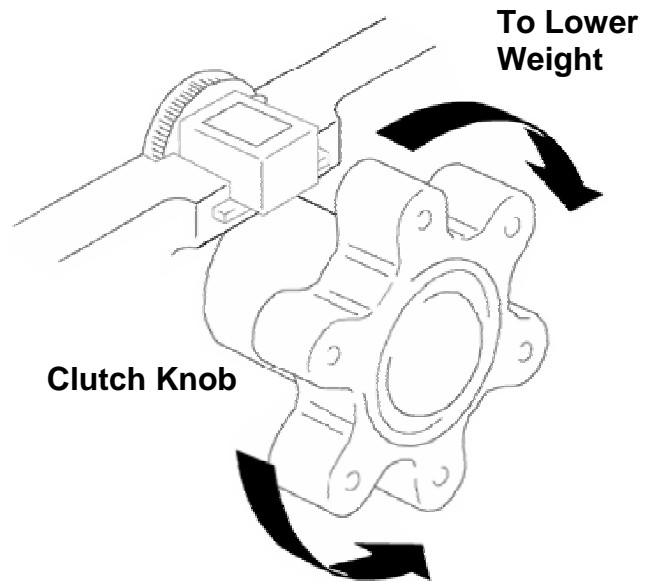

**NOTE:** Make sure that the clutch is well tightened when using powered descent or ascent.

**NOTE:** Actual fishing depth may vary from depth shown on meter due to trolling speed and weight of cannon ball. (See "Blowback")

**NOTE:** If your reel continues to slip no matter how hard you tighten the brake adjust knob, try this suggestion.

1. Unwind the cable from the reel and remove the set screw.
2. Align set screw hole in reel with reel shaft hole by inserting 3/16" or smaller rod. Rotate the reel until you feel the rod drop into the shaft hole.
3. Replace the set screw and tighten until you feel resistance.
4. By gently rocking the reel back and forth while you finish tightening the set screw, you can feel it engage the shaft hole. The half dog point on the set screw **MUST** enter the shaft hole, not just be tightened against the shaft.

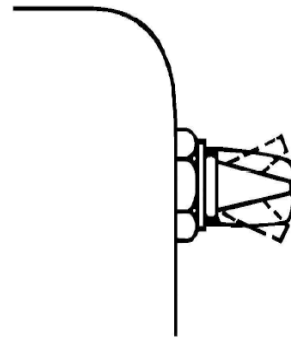

Raise  
Off  
Lower

**Caution:** The brake adjust knob (clutch) should be adjusted so that it is tight enough to hold the weight and the lure at the speed you are trolling. Over tightening may cause damage to your downrigger when weight hangs up on bottom structure or other obstacles.

**Raising the Weight**

Push the toggle switch up momentarily and release. The weight will rise until it reaches the surface and then automatically stop.

If you want to raise the weight farther push the toggle switch up and hold until the weight reaches the desired position, then release.

To stop the weight during ascent, push the toggle switch down momentarily (approximately 1 second).

**Adjusting the Depth Meter**

The Cannon Depth Meter provides non-slip accuracy, plus easy resetting. To reset, just slide the meter away from the reel until the gears are disengaged. Spin meter gear to change setting.

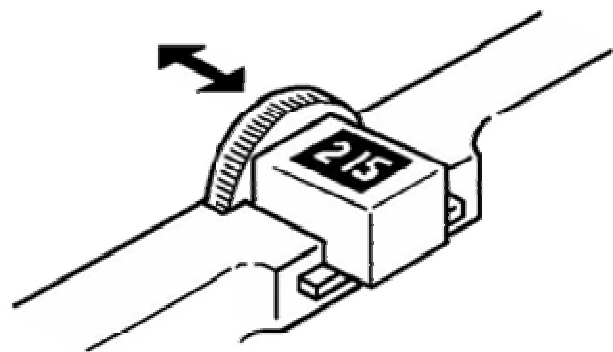

Depth Meter

## The Short Stop System

The Short Stop system is composed of three critical components: the electronic unit, the reel set screw, and the trolling weight insulator.

While the downrigger cable is in the water, there is a minute electrical current that flows between the cable and the grounded metal boat components in the water. When the cable clears the water, this current flow will stop. The Short Stop system senses this interruption and turns off the motor. The trolling weight insulator is used to break the cable contact to the water while the weight is still in the water. The reel set screw allows the circuit path to be made through the structure of the downrigger.

**NOTE:** It may be necessary to use two trolling weight insulators.

Stopping the weight at water level eliminates the cable strain caused by bouncing weights or weights hitting the boom end. Stopping at water level will also keep the weight from hitting the boat hull.

## The Positive Ion Control System

Your boat has an electrical charge around the hull in water. If a boat is properly bonded and properly zinc'd, that charge should be slightly positive when measured from ground to the downrigger cable. Positive Ion Control (PIC) is the use of electricity to control that charge and its fluctuation so that it is always maintained at a specified set voltage.

The practice of setting up and maintaining a slight positive charge on fishing gear has been used by commercial fishermen for many years. This practice has enabled some fisherman to increase yield when used along with other good fishing and boating practices.

Cannon's electric downriggers offer fishermen a big advantage in being able to stabilize and control the positive charge around their boat. Because of the Lexan® construction of the frame, Cannon downriggers are insulated from your boat's hull charge. When the stainless steel downrigger cable is lowered into the water, the natural ionization between the cable and the boat creates a positive charge of 0.7 to 0.9 volts in saltwater and 0.3 to 0.6 volts in fresh water. This natural voltage is dependent upon salinity and mineral content of the water. Your actual voltage may vary.

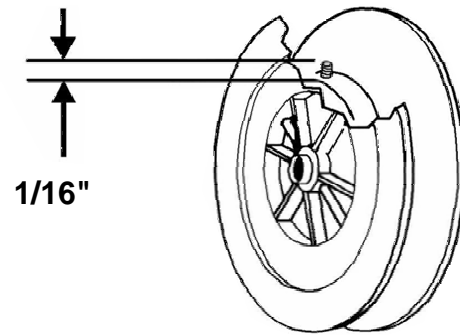

Short Stop System

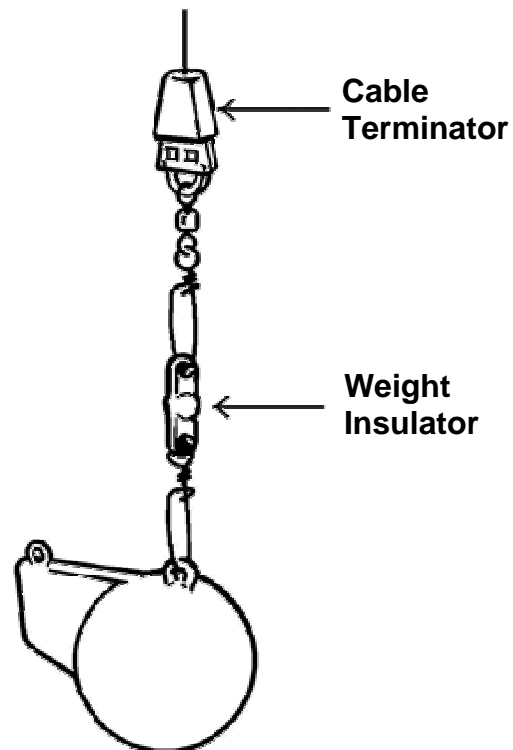

**How the Positive Ion Control System Works**

The PIC system uses an internal circuit that passes the voltage through the drive train of the Mag 20 DT to the reel set screw. The set screw contacts the cable. Care must be taken to ensure contact between the cable and the set screw when replacing the cable.

The positive Ion Control system applies a variable 0.2 to 1.2 volts on the trolling cable at all times. To adjust the Positive Ion Control, simply turn the PIC knob on the back of the Mag 20 DT housing (see below).

**Measuring the Natural Electrolysis and PIC Voltage on Your Boat**

A voltmeter with a scale of zero to one volt will measure the natural electrolysis. Place the ground lead of the meter on the motor or the battery ground. Place the positive lead on the stainless steel downrigger cable while it is in the water. The downrigger must be unplugged. The voltage you measure on the volt meter is your boat's natural electrolysis voltage. Use the same set up to measure the PIC voltage; just plug in the Mag 20 DT and adjust the PIC knob to the voltage desired.

**Using Positive Ion Control**

Positive Ion Control is very effective when trolling. The zone of attraction created at the downrigger wire will attract the fish. It is best to use a short drop back between the downrigger release and the lure. Drop backs of 10 to 20 ft. are typical. A drop back of 50 to 100 ft. will entirely negate the effects of the PIC circuit. Fishing depths greater than 125 ft. may require a slightly higher PIC voltage. If you return to shallow water fishing remember to turn the PIC voltage down again.

The correct PIC setting for your best fishing advantage varies, depending on fish type and location. For example, the proper setting for Puget Sound Steelhead may not be effective for Great Lakes Steelhead. To fully benefit from PIC technology, it is important that you experiment with the PIC setting to find the proper voltage for the gamefish in your area. For more information on this subject, refer to "Secrets of Fishing with Electricity" by Ollie Rode.

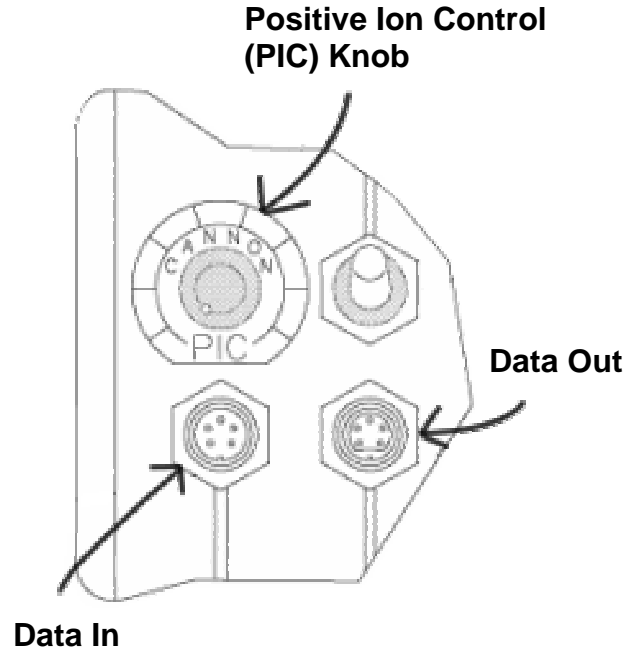

## Blowback

Simply stated, blowback is what happens to the downrigger weight when you pull it through the water behind your boat. As your speed increases, so does the horizontal distance between the weight and your downrigger. The faster you go, the farther the weight is behind you. The farther the weight is behind you, the shallower the weight is.

The following charts provide you with blowback information for three sizes of Cannon downrigger weights pulled at three different speeds with no lures attached and with no current. Current drag, water salinity and the use of non-Cannon products will affect your actual trolling depth.

As an example, the first chart shows that if you are trolling at 4 MPH with an 8 pound weight and you have 100 FT. of cable in the water with no current; the downrigger ball is actually at a depth of about 80 FT.

### Blowback Charts

8-Lb. Weight at 2, 4, and 6 MPH

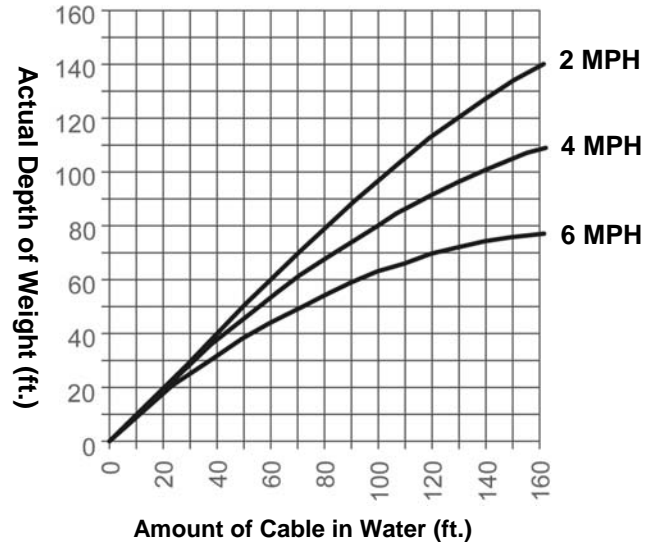

10-Lb. Weight at 2, 4, and 6 MPH

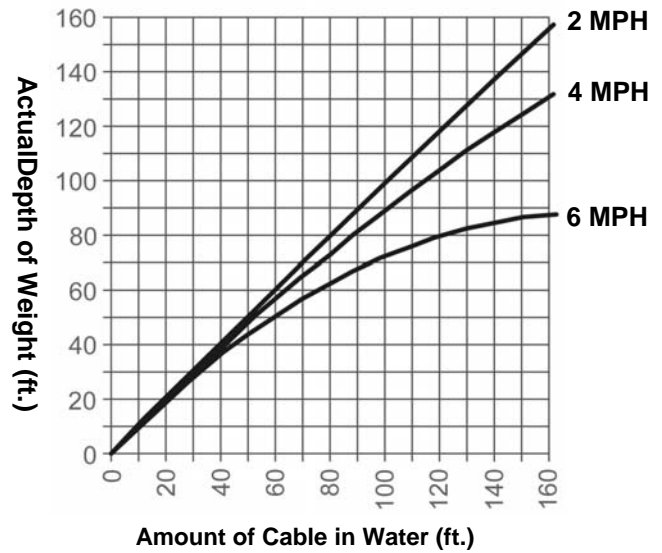

12-Lb. Weight at 2, 4, and 6 MPH

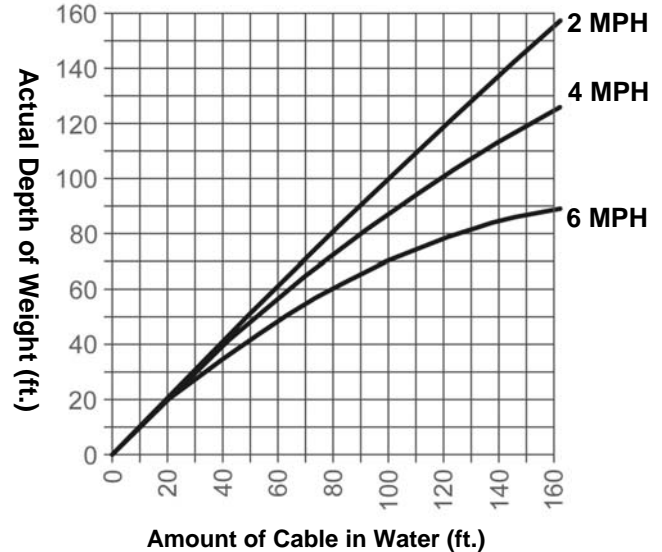



## Trouble Shooting

### PROBLEM:

Up or down will not work.

### SOLUTION:

Check the battery cable polarity then check the battery voltage. A properly connected and charged battery is important for safety and for proper operation of the downrigger.

### PROBLEM:

The Mag 20 DT/HS \ Mag 20 DT/TS fails to continue running after toggle switch is pushed up and held momentarily, while cable is still in water, or is having problems with the PIC voltage.

### SOLUTION:

Make sure your boat is properly bonded. A boat that is properly bonded has an electrical path from the negative battery terminal to all metal parts on the boat that contact water. Additionally, in saltwater the boat must be properly zinc'd to show a natural electrolysis voltage of 0.7 to 0.9 volts. The voltage supply to your downrigger must also be bonded to the boat.

### PROBLEM:

Clutch slips

### SOLUTION:

The set screw in the reel may have come loose off the shaft. Follow the instructions below:

- 1) Unwind the cable from the reel.
- 2) Remove the set screw.
- 3) Align the set screw hole in the reel with the hole in the reel shaft by inserting a 3/16" or smaller rod and rotating the reel until you feel it drop into the shaft hole.
- 4) Replace the set screw and tighten until you feel resistance.
- 5) By gently rocking the reel back and forth while tightening the set screw, you can feel it engage in the shaft hole. The half dog point on the set screw must enter the hole in the shaft; not just be tightened against the reel shaft.
- 6) The set screw should be about 1/16" above the top of the hole when it is properly seated (not so for TS models). The contact between the stainless steel cable and the set screw is important for proper operation of the Positive Ion Control system.

## Maintaining Your Downrigger

Periodically, lightly grease the thrust bearing and bearing race found behind the clutch knob. Replace the cable at least every two years.

**There are no other user serviceable parts on the Mag 20 DTs. Your warranty will be void if the seal on your unit is broken. For repairs or servicing your downrigger refer to the Warranty Information section of this booklet.**

## Ten Good Trolling Tips

**1) Test your lures** over the boat side before sending them down and back. Do this to make sure the lure wiggles and wobbles properly without going belly up or wandering off. Some lures can be adjusted, fine tuned actually, to impart maximum action. For example, a slight bend in the tail of a spoon or twist of the hook eye in the nose of a plug can make a noticeable difference in how the lure performs.

Also, when running two or more lures, make sure the offerings are compatible. Lures that run out of harmony with each other are bound to tangle and that means wasted time to straighten out the mess. Testing them first will avoid the problem.

**2) Consider different sizes, shapes, and colors** of lures. No one has ever figured out with precision what makes a fish strike or snub a lure. There is no doubt, that matching the forage (minnows, crayfish, etc.) in color, shape, action, and size can help trigger those strikes from hungry fish. On the other hand, if fish such as bluegills, small mouth bass or Coho salmon are protecting spawning beds, they may attack whatever is threatening. So, bright colors in lures may out produce bland colors.

**3) Vary trolling speeds.** Goosing the engine now and then or slowing to a crawl every so often will change the action of the lures and may get fish to strike them.

**4) Vary trolling patterns and lead lengths.** The amount of line you let out often determines how deep the lure will run and, to some extent, what degree of action it will impart. For starters, consider running lures about ten feet behind downrigger weights. If flat line trolling, put them back about fifty feet, then experiment depending on what the fish do.

Trolling patterns affect lure action too, that is why some anglers like to wheel a lazy S course. On turns, outside lures will speed up momentarily while inside lures hang for a moment or two. Fish may nail lures that change speeds. Also, zigzag patterns allow for more water coverage, plus it keeps lures out of propeller boil, an important consideration for browns and other wary species.

**5) Locate fish on a vertical plane.** Place lures in areas where fish might be. Skilled fishermen call these areas the "strike zones". They include the edges of the weed beds, structure along bottom, drop-offs, preferred temperature of the target species, and the thermocline. Remember that fish occupy certain areas for certain reasons (sources of food, protective cover, preferred temperatures, etc.).

**6) Consider special knots and swivels.** A good ball bearing swivel will all but eliminate line twist and will aid in getting maximum performance from a lure. Many anglers add the tiny swivels to split rings already on the lure itself. On the other hand, a swivel may dampen the action of a sensitive lure, such as a Rapala. Some fisherman tie tiny improved cinch or loop knots. Loop knots in particular may enhance up and down and side to side action of lures. Any good fishing manual will explain how to tie these and other knots.

**7) Consider releases for flatline trolling.** A good tip is to secure a piece of downrigger cable or heavy monofilament to the water ski hook or handle below the transom of most boats. To the other end of the mono or cable, add a pinch-release. After letting out your lure to the desire distance, put the rod in its holder, then bend the tip and secure the fishing line in the release.

**8) Add a weed guard.** Having trouble with weeds hanging up lures? Consider tying a three-inch piece of monofilament a foot above the lure. Leaves, smaller weeds and other debris may catch here momentarily then fall off to the side of the lure without tangling. Weedless lures are another smart consideration. Downrigger cables are effective weed catchers when trolling for pike, muskies, or bass in weed-infested lakes.

**9) Add a stinger hook.** When fish short strike, slap at lures without becoming hooked, adding a stinger hook can solve the problem. Simply tie a treble hook to one end of a four inch piece of monofilament and then tie the extra hook to the last gang of hooks on your lure. The stinger hook, which trails the lure, provides extra insurance.

**10) Keep hooks sharp.** Some of the best fishermen sharpen all hooks after every fish caught. Hooks get dull through both use and misuse, and probably more fish are lost to dull points than anything else.

## CANNON® LIMITED WARRANTY

Johnson Outdoors Inc. warrants to the original purchaser that if the accompanying product (see exclusions below) proves to be defective in material or workmanship within the following warranty periods, Johnson Outdoors Inc. will, at its option, either repair or replace same without charge (but no cash refunds will be made):

- 1) The boom, motor, and reels, plus all Lexan®\* parts, including but not limited to frames and bases, will be free from defects in materials and workmanship, subject to normal wear and tear, for the original purchaser's lifetime.
- 2) All other items will have 1-year limited warranties from the date of original retail purchase, except THE FOLLOWING ITEMS THAT HAVE NO WARRANTY WHATSOEVER: boot covers, clothing, Dacron line, rubber bands, swivel lock pin, weights, and wire cable.

This limited warranty may be enforced only by the original purchaser; all subsequent purchasers acquire the product "as is" without any benefit of this limited warranty. Repair or replacement of the product as set forth in this limited warranty shall be the original purchaser's sole and exclusive remedy and Johnson Outdoors Inc.'s sole and exclusive liability for breach of this warranty.

### EXCLUSIONS

This warranty does not apply in the following circumstances:

- When the product has been connected, installed, combined, altered, adjusted, serviced, repaired, or handled in a manner other than according to the instructions furnished with the product
- When a serial number has been effaced, altered, or removed
- When any defect, problem, loss, or damage has resulted from any accident, misuse, negligence, carelessness, or abnormal use, or from any failure to provide reasonable and necessary maintenance in accordance with the instructions of the owner's manual

### LIMITATION AND EXCLUSION OF IMPLIED WARRANTIES AND CERTAIN DAMAGES

THERE ARE NO EXPRESS WARRANTIES OTHER THAN THESE LIMITED WARRANTIES. JOHNSON OUTDOORS INC. DISCLAIMS LIABILITY FOR INCIDENTAL AND CONSEQUENTIAL DAMAGES, AND IN NO EVENT SHALL ANY IMPLIED WARRANTIES (EXCEPT ON THE BOOM, MOTOR, REELS, AND ALL LEXAN®\* PARTS), INCLUDING ANY IMPLIED WARRANTY OF MERCHANTABILITY OR FITNESS FOR PARTICULAR PURPOSE, EXTEND BEYOND ONE YEAR FROM THE DATE OF PURCHASE (AND IN THE CASE OF THE BOOT COVERS, CLOTHING, DACRON LINE, RUBBER BANDS, SWIVEL LOCK PIN, WEIGHTS, AND WIRE CABLE, JOHNSON OUTDOORS INC. DISCLAIMS ALL IMPLIED WARRANTIES). THIS WRITING CONSTITUTES THE ENTIRE AGREEMENT OF THE PARTIES WITH RESPECT TO THE SUBJECT MATTER HEREOF; NO WAIVER OR AMENDMENT SHALL BE VALID UNLESS IN WRITING SIGNED BY JOHNSON OUTDOORS INC.

Some states do not allow limitations on how long an implied warranty lasts or the exclusion or limitation of consequential damages, so the above limitation or exclusion may not apply to you. This warranty gives you specific legal rights, and you may also have other rights that vary from state to state.

\* Lexan is a registered trademark of General Electric.

## CANNON® SERVICE POLICY

### AFTER THE APPLICABLE WARRANTY PERIOD

After the applicable warranty period, or, if one of the above exclusions applies, Cannon® products will be repaired for a charge of parts plus labor. All factory repairs, after the applicable warranty period, carry a 90-Day Limited Warranty, subject to the exclusions and limitations stated above.

### TO ENFORCE WARRANTY OR TO OBTAIN REPAIRS AFTER WARRANTY

To obtain warranty service in the U.S., the downrigger or part believed to be defective and the proof of original purchase (including the date of purchase) must be presented to a Cannon® Authorized Service Center or to Cannon®'s factory service center in Mankato, MN. Except as noted below, any charges incurred for service calls, transportation or shipping/freight to/from the Cannon® Authorized Service Center or Cannon®'s factory, labor to haul out, remove, re-install or re-rig products for warranty service, or any similar items are the sole and exclusive responsibility of the purchaser. Downriggers purchased outside of the U.S. (or parts of such downriggers) must be returned prepaid with proof of purchase (including the date of purchase and serial number) to any Authorized Cannon® Service Center in the country of purchase. Warranty service can be arranged by contacting a Cannon® Authorized Service Center listed on the enclosed sheet, or by contacting the factory at 1-800-227-6433 or Fax 1-800-527-4464. If the necessary repairs are covered by the warranty, we will pay the return shipping charges to any destination within the United States.

**DO NOT** return your Cannon® downrigger or parts to your retailer. Your retailer is not authorized to repair or replace them.

Major parts, such as the motor and main frame, must be returned to Johnson Outdoors Inc. in Mankato, Minnesota, or a Cannon® Authorized Service Center, for repair or replacement. To reduce shipping costs, we suggest removal of loose parts such as the boom and rod holders. Small parts that can be easily removed such as the handle and/or the counter, may be removed from the downrigger and returned for repair or replacement.

**Retain your sales receipt! Proof of purchase must accompany product when returned.**

**Return Address:** Johnson Outdoors Inc.  
Cannon Division  
121 Power Drive  
Mankato, MN 56001

### FOR YOUR INFORMATION:

\_\_\_\_\_ Serial No.  
\_\_\_\_\_ Date Purchased  
\_\_\_\_\_ Store Where Purchased

**RETAIN THIS SECTION FOR YOUR RECORDS**

## Authorized Service Centers

Your new Cannon® Downrigger was built to exacting specifications under rigid quality control to provide you years of trouble-free operation. If it should ever need adjustment or service, you may send it to any Cannon® Authorized Service Center near you.

### ALASKA

Alaska Performance  
6820 Arctic Blvd  
Anchorage 99518  
907-522-8965

North Repair  
172 Chandler Rd  
Ketchikan 99902  
907-225-3690

### CALIFORNIA

Fisherman's Warehouse  
9035 Folsom Blvd  
Sacramento 95826  
916-362-1259

B & F Rod & Reel  
1028 W. 4th St.  
Ontario 91762  
909-988-9229

### FLORIDA

Master Repair, Inc.  
4446 SE Commerce Ave  
Stuart 34997  
772-220-7777

Pace's Minn Kota Service Center  
3618-B Fowler St  
Ft Myers 33901  
239-939-9851

Trolling Motor Service  
4125 Blanding Blvd  
Jax 32210  
904-573-0480

### KENTUCKY

Wayne Co. Marine  
Rt 1 Box 290-A  
Monticello 42633  
606-348-5483

### MICHIGAN

Cannon Service Center  
2080 Lakeshore Dr.  
Muskegon 49441  
231-731-8352

### MICHIGAN (continued)

Trolling Motor Repair  
119 E Main St Box 77  
Kingsley 49649  
231-263-5998

Coastline Power & Lighting, LLC  
8338 Anchor Bay Dr  
Algonac 48001  
810-794-5951

### MINNESOTA

Electrotech  
1332 E. 4th St.  
Duluth 55805  
218-727-8919

Lake of the Woods Marine  
3208 Bur Oak Rd  
Baudette 56623  
213-634-2289

### NEVADA

Pyramid Lake Store  
29555 Pyramid Hwy  
Sutcliffe 89510  
775-476-0555

### NEW HAMPSHIRE

Paugus Bay Sporting Goods  
135 Weirs Blvd  
Laconia 03246  
603-524-4319

### NEW JERSEY

Sportsman Center  
Rt. 130  
Bordentown 08505  
609-298-5300

### NEW YORK

A & P Custom Tackle  
155 Hidley Rd  
Wynantskill 12198  
518-283-5920

Bill's Hooks  
5139 W Lake Rd  
Dunkirk 14048  
716-366-0268

### NEW YORK (continued)

Fish307.Com  
1571 State Rt. 9  
Lake George 12845  
518-798-9203

Screwy Louie's  
596 Main St. PO Box 37  
Fairhaven 13064  
315-947-6348

Tony's Reel Repair  
7686 Michael Rd  
Orchard Park 14127  
716-662-5692

### NORTH CAROLINA

Fisherman's Friend  
1401 S Ridge Ave  
Kannapolis 28083  
704-934-2122

### OREGON

Ollie Damon's  
236 SE. Grand Ave.  
Portland 97214  
503-232-3193

### PENNSYLVANIA

Dave's Sport Center  
1127 N. Easton Rd.  
Doylestown 18902  
215-766-8000

### SOUTH CAROLINA

Port-Tronics  
1904 Piedmont Hwy.  
Greenville 29605  
864-299-1432

### SOUTH DAKOTA

Pierre Sports Center  
1440 N. Garfield  
Pierre 57501  
605-224-5546

### TEXAS

Bob Ridgway Repair  
605 W. Mockingbird  
Dallas 75247  
214-630-8161

### UTAH

Swede R's at Croft Power Equipment  
596 W. 1500 St.  
Woods Cross 84087  
801-397-1675

### VERMONT

Vermont Home & Marine  
323 Industrial Ave.  
Williston 05487  
802-658-5427

### VIRGINIA

Queen's Creek Reel & Downrigger  
Intersection of Routes 3 & 198  
PO Box 900  
Cobbs Creek 23035  
804-725-3889

### WASHINGTON

Pacific NW Downrigger Repair  
45795 Geo Star Rd.  
PO Box 238  
Grand Coulee 99133  
509-633-0708

Northern Sales  
510 E. College Way  
Mount Vernon 98273  
360-424-8522

### DROP OFF LOCATIONS

The Duffle Bag  
8207 S. Tacoma Way  
Lakewood, WA 98499

Jerry's Surplus  
2031 Broadway  
Everett, WA 98201

### WISCONSIN

Howie's Tackle  
223 Greenbay Rd.  
Sturgeon Bay 54235  
920-746-9916

For a current list of authorized Cannon Service Centers, including those outside of the US and Canada, please see our web page at [www.cannondownriggers.com](http://www.cannondownriggers.com).



All CANNON Downriggers are covered by US Pat.D-269, 992. Copyright 2006 Johnson Outdoors, Inc. All rights reserved.  
Conforms to 89/336/EEC (EMC) under standards EN 55022A, EN 50082-2 since 1996 LN V9677264

**WARNING:** This product contains chemical(s) known to the state of California to cause cancer and/or reproductive toxicity.

Form No. 339-7101 Rev 07/07

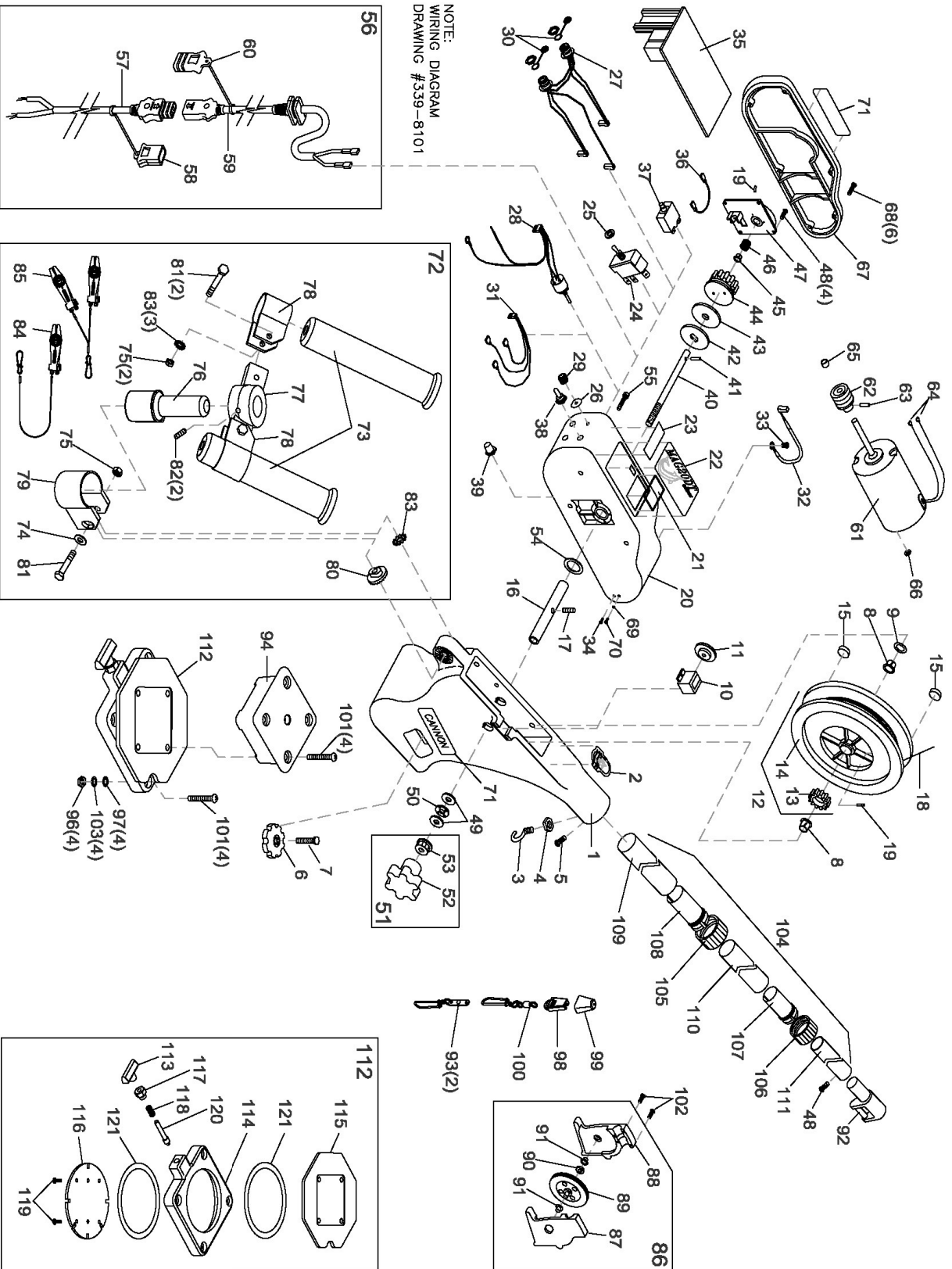

NOTE:  
WIRING DIAGRAM  
DRAWING #339-8101

In the U.S.A., replacement parts may be ordered directly from CANNON Parts Dept., 121 Power Drive, Mankato, Minnesota 56001. In Canada, parts may be ordered from any of the Canadian Authorized Service Centers shown on the enclosed list. Be sure to provide the MODEL and SERIAL numbers of your downtrigger when ordering parts. Please use the correct part numbers from the parts list. Payment for any parts ordered from the CANNON parts department, may be by cash, personal check, Discover Card, MasterCard or VISA. To order, call 1-800-227-6433 or FAX 1-800-527-4464.

1	3392500	FRAME - LARGE BLACK (LEXAN)	42	0467695	BRAKE PLATE - REEL	83	9430160	>WASHER - STAR 5/16" [3.EA]
2	4427005	NOSE DECAL MAGNUM	43	1264670	CLUTCH PAD	84	2277002	>UNIVERSAL LINE RELEASE
3	9040040	HOOK - 1/4" - 20 ROLLED	44	1433074	GEAR - DRIVER WORM	85	3998600	>UNI-STACKER RELEASE
4	2263102	NUT - HEX 1/4"-20	45	9010003	BEARING- DRIVE SHAFT NYLINER	86	3992300	SWIVEL HEAD ASSEMBLY
5	9280750	SCREW - 1/4" - 20 (RH) x 3/4" PPH	46	9400005	SPRING - SHAFT CONTACT	87	0267001	>SIDE PLATE (RH)
6	0849615	BASE LOCK KNOB	47	4421002	COVER - GEAR CASE	88	0267002	>SIDE PLATE (LH)
7	9040340	BOLT - 3/8"-16 X 1-1/2" HEX	48	2372100	SCREW - #8 x 5/8" PPHMS [5.EA]	89	0269726	>PULL Y - SWIVEL HEAD
8	9010001	BEARING- REEL SHAFT NYLINER [2.EA]	49	9010310	WASHER - THRUST [2.EA]	90	3397300	>WASHER - .735 OD X .36 ID
9	9430210	WASHER - 1-1/16" OD X 7/8" ID (NYLON)	50	9010280	BEARING - THRUST	91	9010070	>HDW BEARING BRASS[2.EA]
10	0220477	DEPTH COUNTER - 3 DIGIT	51	2998906	KNOB BRAKE	92	2227820	BOOM END - TELESCOPIC (LEXAN)
11	0833561	GEAR - COUNTER	52	0649001	>KNOB - HAND ADJUST	93	2200148	SNAP & INSULATOR [2.EA]
12	0274000	REEL ASSEMBLY - HS ELECTRIC	53	9130390	>NUT - KNURLED INSERT 3/8"-24	94	1007334	MOUNTING BASE (LEXAN)
13	0233560	>GEAR REEL	54	1479070	O-RING - REEL SHAFT	95	2994893	*BAG ASSEMBLY, MOUNTING (KIT #3)
14	0274731	REEL MAGNET [2.EA]	55	9370205	SCREW - 1/4" x 3/4" HEX WASH HD [3.EA]	96	2263102	NUT - HEX 1/4"-20 [4.EA]
15	1459666	SHAFT - REEL	56	3993200	POWER CABLE ASSEMBLY	97	2371712	WASHER - 9/32" FLAT [4.EA]
16	1480071	SCREW - SET 5/16"-18 x 1-3/4" (REEL)	57	3393200	>POWER CABLE - BATTERY	98	9100100	TERMINATOR
17	9340131	SPOOL CABLE SS [400.FT]	58	3393201	>CAP - POWER CABLE - BATTERY	99	9100101	TERMINATOR CUSHION
18	3775397	CABLE LEADER SLEEVE [2.EA]	59	3393202	>POWER CABLE - MOTOR	100	9100620	TERMINATOR SNAP & SWIVEL
19	9100070	MOTOR HOUSING - MAG 20 (LEXAN)	60	3393210	>CAP - POWER CABLE -MOTOR	101	9280725	BOLT - TRUSS 1/4" - 20 x 2-1/2" [8.EA]
20	3396530	LENSE - WINDOW DISPLAY	61	1458001	GEAR - WORM MOTOR	102	9370010	SCREW - #4 x 1/2" PPH [3.EA]
21	1497071	DECAL - LARGE, MAG 20 DT/HS	62	1497070	TERMINAL - MOTOR, FEM 12-10 [2.EA]	103	9950357	WASHER - LOCK 1/4" SPLIT [4.EA]
22	3396520	SWITCH - UP/DN CONTROL	63	9250001	BEARING - MOTOR SHAFT	104	2210821	TELESCOPIC BOOM
23	3396702	WASHER - SHIM, .750 x .1 UP/DN SWITCH	64	700032	COVER - MOTOR HOUSING (LEXAN)	105	2219822	>BASE TUBE CLAMP
24	2286792	DECAL - PIC KNOB DIAL	65	9010002	SCREW - #8-18 x 1-1/4" PPHMS SS [6.EA]	106	2219823	>MID TUBE CLAMP
25	2286793	CABLE ASSY - MAG20DT (DATA IN/OUT)	66	2263112	NUT - HEX #10-32 BZ	107	2222825	>MID TUBE COLLET
26	33965703	POSTIVE ION CONTROL POT	67	1421072	COVER - MOTOR HOUSING (LEXAN)	108	2222826	>BASE TUBE COLLET
27	050268	KNOB - POSITIVE ION CONTROL	68	3393400	O-RING - SMALL	109	2290828	>BOOM BASE TUBE (BLACK)
28	050215	CAP - CONNECTION PORT [2.EA]	69	701007	SCREW - #6-20 X 3/8"	110	2290829	>BOOM MID TUBE (BLACK)
29	611005	CABLE ASSY - MAG20DT UP/DN SWITCH	70	2332103	DECAL - CANNON LARGE [2.EA]	111	2290830	>BOOM END TUBE (BLACK)
30	700176	CABLE ASSY - ANTENNA IN (SENSOR)	71	3395630	BAG ASSY - DUAL REAR ROD HOLDER	112	2998905	SWIVEL BASE
31	609209	INSERT - 1/4" PRESS THD #6-32	72	3991902	>TUBE - ROD HOLDER [2.EA]	113	2249001	>KNOB - RELEASE PIN (LEXAN)
32	609253	SCREW - MACH #6-32 x 3/8" SS	73	0290796	>WASHER - 5/16" FLAT	114	2267001	>BASE PLATE (LEXAN)
33	1234002	CONTROL BOARD - MAG 20 DT	74	2151726	>NUT - 5/16"-18 SS [3.EA]	115	2267002	>SWIVEL PLATE (LEXAN)
34	603103	WIRE - CIRCUIT BREAKER JUMPER (RED)	75	2383106	>BRACKET - DUAL ROD (LEXAN)	116	2267006	>INDEXING PLATE (TAPPED)
35	050265	CIRCUIT SWITCH BOOT	76	2411386	>CLAMP - ROD HOLDER [2.EA]	117	2277001	>NUT - RETAINER RELEASE
36	1296831	CIRCUIT BREAKER BOOT	77	2411390	>DISK - ROD HOLDER	118	2287002	>SPRING - RELEASE PIN
37	3398205	SHAFT - DRIVE	78	2419470	>BOLT - HEX 5/16"-18 x 2" [3.EA]	119	2372100	>SCREW - #8 x 5/8" PPHMS [2.EA]
38	1221490	PIN - DRIVE SHAFT 3/16" ROLL SS	79	3319005	>SCREW - SET 3/8"-16 x 5/8" [2.EA]	120	3392600	>RELEASE PIN
39	1221491		80	3325002		121	9010004	>BEARING - SWIVEL BASE [2.EA]
40	1480070		81	9040310				
41	9250002		82	9340101				

> PART OF ASSEMBLY

▶ ITEM CANNOT BE SOLD SEPARATELY

\* PARTS USED BUT NOT SHOWN

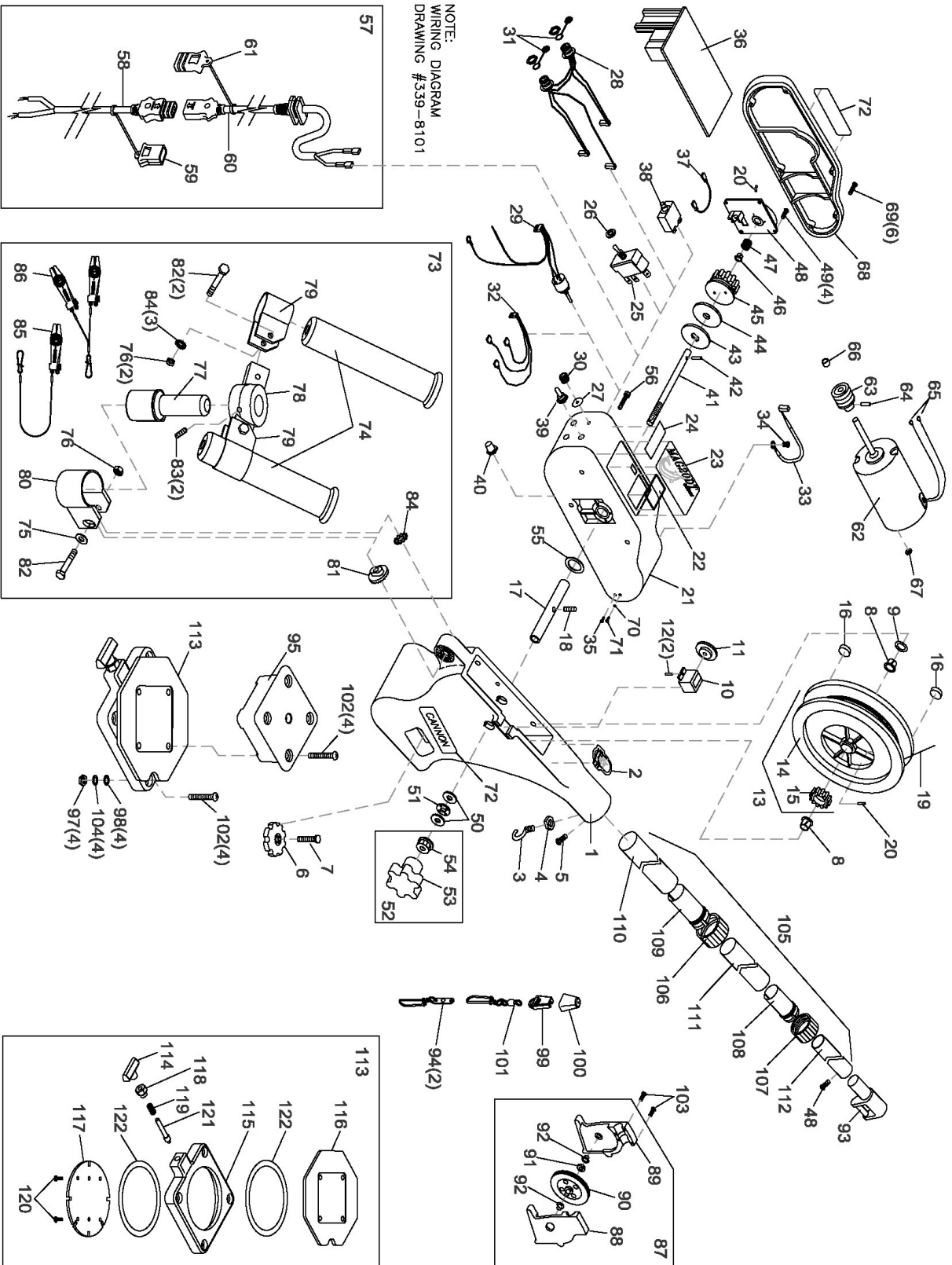

In the U.S.A., replacement parts may be ordered directly from CANNON Parts Dept., 121 Power Drive, Mankato, Minnesota 56001. In Canada, parts may be ordered from any of the Canadian Authorized Service Centers shown on the enclosed list. Be sure to provide the MODEL and SERIAL numbers of your downgrader when ordering parts. Please use the correct part numbers from the parts list. Payment for any parts ordered from the CANNON parts department, may be by cash, personal check, Discover Card, MasterCard or VISA. To order, call 1-800-227-6433 or FAX 1-800-527-4464.

1	3392500	FRAME - LARGE BLACK (LEXAN)	42	9250002	PIN - DRIVE SHAFT 3/16" ROLL SS	83	9340101	>SCREW - SET 3/8"-16 x 5/8" (2EA)
2	4427005	NOSE DECAL MAGNIUM	43	0467695	BRAKE PLATE - REEL	84	9430160	>WASHER - STAR 5/16" (3EA)
3	9040040	HOOK - 1/4" - 20 ROLLED	44	1264670	CLUTCH PAD	85	2277002	>UNIVERSAL LINE RELEASE
4	2263102	NUT - HEX 1/4"-20	45	1433074	GEAR - DRIVER WORM	86	3998600	>UNI-STACKER RELEASE
5	9280750	SCREW - 1/4" - 20 (RH) x 3/4" PPH	46	9010003	BEARING - DRIVE SHAFT NYLINER	87	3992300	SWIVEL HEAD ASSEMBLY
6	0849615	BASE LOCK KNOB	47	9400005	SPRING - SHAFT CONTACT	88	0267001	▶SIDE PLATE (RH)
7	9040340	BOLT - 3/8"-16 X 1-1/2" HEX	48	4421002	COVER - GEAR CASE	89	0267002	▶SIDE PLATE (LH)
8	9010001	BEARING - REEL SHAFT NYLINER (2EA)	49	2372100	SCREW - #8 x 5/8" PPHMS (5EA)	90	0269726	▶PULLY - SWIVEL HEAD
9	9430210	WASHER - 1-1/16" OD X 7/8" ID (NYLON)	50	9010310	WASHER - THRUST (2EA)	91	3397300	▶WASHER - 735 OD X .36 ID
10	3320011	DEPTH COUNTER - 3 DIGIT (METRIC)	51	9010280	BEARING - THRUST	92	9010070	▶HDW BEARING BRASS(2EA)
11	3333010	COUNTER GEAR (METRIC)	52	2998906	KNOB BRAKE	93	2227820	BOOM END - TELESCOPIC (LEXAN)
12	0854654	COUNTER CUSHION/STOPPER (2EA)	53	0649001	▶KNOB - HAND ADJUST	94	2200148	SNAP & INSULATOR (2EA)
13	3374010	REEL ASSY - HS ELECTRIC (METRIC)	54	9130390	▶NUT - KNURLED INSERT 3/8"-24	95	1007334	MOUNTING BASE (LEXAN)
14	0274731	▶REEL - MACHINED 3.75"	55	1479070	O-RING - REEL SHAFT	96	2994893	*BAG ASSEMBLY, MOUNTING (KIT #3)
15	3333011	>GEAR REEL (METRIC)	56	9370205	SCREW - 1/4" x 3/4" HEX WASH HD (3EA)	97	2263102	NUT - HEX 1/4"-20 (4EA)
16	1459666	REEL MAGNET (2EA)	57	3993200	POWER CABLE ASSEMBLY	98	2371712	WASHER - 9/32" FLAT (4EA)
17	1480071	SHAFT - REEL	58	3393200	>POWER CABLE - BATTERY	99	9100100	TERMINATOR
18	9340131	SCREW - SET 5/16"-18 x 1-3/4" (REEL)	59	3393201	>CAP - POWER CABLE - BATTERY	100	9100101	TERMINATOR CUSHION
19	3775397	SPOOL CABLE SS (400.FT)	60	3393202	>POWER CABLE - MOTOR	101	9100620	TERMINATOR SNAP & SWIVEL
20	9100070	CABLE LEADER SLEEVE (2EA)	61	3393210	>CAP - POWER CABLE - MOTOR	102	9280725	BOLT - TRUSS 1/4" - 20 x 2-1/2" (8EA)
21	3396530	MOTOR HOUSING - MAG 20 (LEXAN)	62	1458001	MOTOR 12V DC	103	9370010	SCREW - #4 x 1/2" PPH (3EA)
22	1497071	LENSE - WINDOW DISPLAY	63	1497070	GEAR - WORM MOTOR	104	9950357	WASHER - LOCK 1/4" SPLIT (4EA)
23	3396620	DECAL - LARGE, MAG 20 DT/HS	64	9250001	PIN - MOTOR, 3/32" X 3/4" ROLL SS	105	2210821	TELESCOPIC BOOM
24	3396702	DECAL - POSITIVE ION CONTROL	65	700032	TERMINAL - MOTOR, FEM 12-10 (2EA)	106	2219822	>BASE TUBE CLAMP
25	2286792	SWITCH - UP/DN CONTROL	66	9010002	BEARING - MOTOR SHAFT	107	2219823	>MID TUBE CLAMP
26	2286793	WASHER - SHIM, .750 x .1 UP/DN SWITCH	67	2263112	NUT - HEX #10-32 BZ	108	2222825	>MID TUBE COLLET
27	3396703	DECAL - PIC KNOB DIAL	68	1421072	COVER - MOTOR HOUSING (LEXAN)	109	2222826	>BASE TUBE COLLET
28	050268	CABLE ASSY - MAG20DT (DATA IN/OUT)	69	3393400	SCREW - #8-18 x 1-1/4" PPHSMS SS (6EA)	110	2290828	▶BOOM BASE TUBE (BLACK)
29	050215	POSITIVE ION CONTROL POT	70	701007	O-RING - SMALL	111	2290829	▶BOOM MID TUBE (BLACK)
30	611005	KNOB - POSITIVE ION CONTROL	71	2332103	SCREW-#6-20 X 3/8"	112	2290830	▶BOOM END TUBE (BLACK)
31	700176	CAP - CONNECTION PORT (2EA)	72	3396630	DECAL - CANNON LARGE (2EA)	113	2998905	SWIVEL BASE
32	609209	CABLE ASSY - MAG20DT UP/DN SWITCH	73	3991902	BAG ASSY - DUAL REAR ROD HOLDER	114	2249001	>KNOB - RELEASE PIN (LEXAN)
33	6092653	CABLE ASSY - ANTENNA IN (SENSOR)	74	0290796	>TUBE - ROD HOLDER (2EA)	115	2267001	>BASE PLATE (LEXAN)
34	1234002	INSERT - 1/4" PRESS THD #6-32	75	2151726	>WASHER - 5/16" FLAT	116	2267002	>SWIVEL PLATE (LEXAN)
35	603103	SCREW - MACH #6-32 X 3/8" SS	76	2383106	>NUT - 5/16"-18 SS (3EA)	117	2267006	>INDEXING PLATE (TAPPED)
36	050265	CONTROL BOARD - MAG 20 DT	77	2411386	>POST - REAR MOUNT (LEXAN)	118	2277001	>NUT - RETAINER RELEASE
37	1296831	WIRE - CIRCUIT BREAKER JUMPER (RED)	78	2411390	>BRACKET - DUAL ROD (LEXAN)	119	2287002	>SPRING - RELEASE PIN
38	3398205	CIRCUIT BREAKER - 30 AMP	79	2419470	>CLAMP - ROD HOLDER (2EA)	120	2372100	>SCREW - #8 x 5/8" PPHMS (2EA)
39	1221490	UP/DN SWITCH BOOT	80	3319005	>CLAMP - ROD HOLDER w/ SLOT	121	3392600	>RELEASE PIN
40	1221491	CIRCUIT BREAKER BOOT	81	3325002	>DISK - ROD HOLDER	122	9010004	>BEARING - SWIVEL BASE (2EA)
41	1480070	SHAFT - DRIVE	82	9040310	>BOLT - HEX 5/16"-18 x 2" (3EA)			

> PART OF ASSEMBLY

▶ ITEM CANNOT BE SOLD SEPARATELY

\* PARTS USED BUT NOT SHOWN



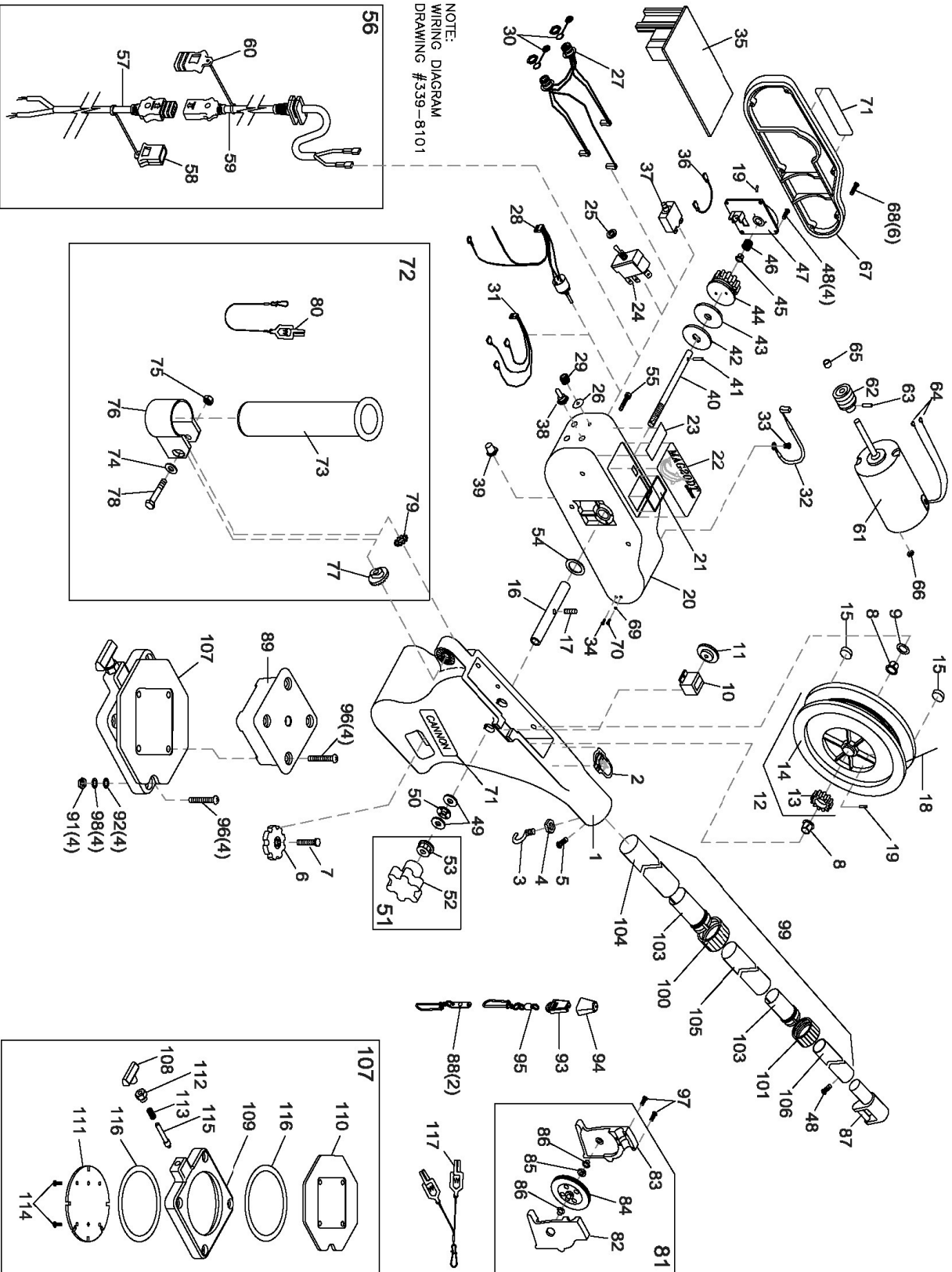

NOTE:  
WIRING DIAGRAM  
DRAWING #339-8101

In the U.S.A., replacement parts may be ordered directly from CANNON Parts Dept., 121 Power Drive, Mankato, Minnesota 56001. In Canada, parts may be ordered from any of the Canadian Authorized Service Centers shown on the enclosed list. Be sure to provide the MODEL and SERIAL numbers of your downrigger when ordering parts. Please use the correct part numbers from the parts list. Payment for any parts ordered from the CANNON parts department, may be by cash, personal check, Discover Card, MasterCard or VISA. To order, call 1-800-227-6433 or FAX 1-800-527-4464.

1	3392505	FRAME - LARGE WHITE (LEXAN)	40	1480070	SHAFT - DRIVE	79	9430160	>WASHER - STAR 5/16"
2	4427005	NOSE DECAL MAGNUM	41	9250002	PIN - DRIVE SHAFT 3/16" ROLL SS	80	2200109	>OFFSHORE SALTWATER RELEASE
3	9040040	HOOK - 1/4" - 20 ROLLED	42	0467695	BRAKE PLATE - REEL	81	3992300	SWIVEL HEAD ASSEMBLY
4	2263102	NUT - HEX 1/4"-20	43	1264670	CLUTCH PAD	82	0267001	▶SIDE PLATE (RH)
5	9280750	SCREW - 1/4" - 20 (RH) x 3/4" PPH	44	1433074	GEAR - DRIVER WORM	83	0267002	▶SIDE PLATE (LH)
6	0849615	BASE LOCK KNOB	45	9010003	BEARING - DRIVE SHAFT NYLINER	84	0269726	▶PULLY - SWIVEL HEAD
7	9040340	BOLT - 3/8"-16 X 1-1/2" HEX	46	9400005	SPRING - SHAFT CONTACT	85	3397300	▶WASHER - .735 OD X .36 ID
8	9010001	BEARING - REEL SHAFT NYLINER [2.EA]	47	4421002	COVER - GEAR CASE	86	9010070	▶HDW BEARING BRASS[2.EA]
9	9430210	WASHER - 1-1/16" OD X 7/8" ID (NYLON)	48	2372100	SCREW - #8 x 5/8" PPHMS [5.EA]	87	2227820	BOOM END - TELESCOPIC (LEXAN)
10	0220477	DEPTH COUNTER - 3 DIGIT	49	9010310	WASHER - THRUST [2.EA]	88	2200148	SNAP & INSULATOR [2.EA]
11	0833561	GEAR - COUNTER	50	9010280	BEARING - THRUST	89	1007334	MOUNTING BASE (LEXAN)
12	3397912	REEL ASSEMBLY - TS ELECTRIC	51	2998906	KNOB BRAKE	90	2994893	*BAG ASSEMBLY, MOUNTING (KIT #3)
13	0233560	>GEAR REEL	52	0649001	▶KNOB - HAND ADJUST	91	2263102	NUT - HEX 1/4"-20 [4.EA]
14	3397902	▶REEL - 3.75" SS	53	9130390	▶NUT - KNURLED INSERT 3/8"-24	92	2371712	WASHER - .9132" FLAT [4.EA]
15	1459666	REEL MAGNET [2.EA]	54	1479070	O-RING - REEL SHAFT	93	9100100	TERMINATOR
16	1480071	SHAFT - REEL	55	9370205	SCREW - 1/4" x 3/4" HEX WASH HD [3.EA]	94	9100101	TERMINATOR CUSHION
17	9340131	SCREW - SET 5/16"-18 x 1-3/4" (REEL)	56	3993200	POWER CABLE ASSEMBLY	95	9100620	TERMINATOR SNAP & SWIVEL
18	3775397	SPOOL CABLE SS [400.FT]	57	3393200	>POWER CABLE - BATTERY	96	9280725	BOLT - TRUSS 1/4" - 20 x 2-1/2" [8.EA]
19	9100070	CABLE LEADER SLEEVE [2.EA]	58	3393201	>CAP - POWER CABLE - BATTERY	97	9370010	SCREW - #4 x 1/2" PPH [3.EA]
20	3396534	MOTOR HOUSING - MAG 20 TS (LEXAN)	59	3393202	>POWER CABLE - MOTOR	98	9950357	WASHER - LOCK 1/4" SPLIT [4.EA]
21	1497071	LENS - WINDOW DISPLAY	60	3393210	>CAP - POWER CABLE -MOTOR	99	3392010	TELESCOPIC BOOM SS
22	3395601	DECAL - LARGE, MAG 20 DT/TS	61	1458001	MOTOR 12V DC	100	2219822	>BASE TUBE CLAMP
23	3395700	DECAL - POSITIVE ION CONTROL TS	62	1497070	GEAR - WORM MOTOR	101	2219823	>MID TUBE CLAMP
24	2286792	SWITCH - UP/DN CONTROL	63	9250001	PIN - MOTOR 3/32" X 3/4" ROLL SS	102	2222825	>MID TUBE COLLET
25	2286793	WASHER - SHIM .750 x .1 UP/DN SWITCH	64	700032	TERMINAL - MOTOR, FEM 12-10 [2.EA]	103	2222826	>BASE TUBE COLLET
26	3395701	DECAL - PIC KNOB DIAL TS	65	9010002	BEARING - MOTOR SHAFT	104	3392001	▶BOOM BASE TUBE (SS)
27	050268	CABLE ASSY - MAG20DT (DATA IN/OUT)	66	2263112	NUT - HEX #10-32 BZ	105	3392002	▶BOOM MID TUBE (SS)
28	050215	POSITIVE ION CONTROL POT	67	3390201	COVER - MOTOR HOUSING TS (LEXAN)	106	3392003	▶BOOM END TUBE (SS)
29	611005	KNOB - POSITIVE ION CONTROL	68	3393400	SCREW - #8-18 x 1-1/4" PPHMS SS [6.EA]	107	2998905	SWIVEL BASE
30	700176	CAP - CONNECTION PORT [2.EA]	69	701007	O-RING - SMALL	108	2249001	>KNOB - RELEASE PIN (LEXAN)
31	609209	CABLE ASSY - MAG20DT UP/DN SWITCH	70	2332103	SCREW #6-20 X 3/8"	109	2267001	>BASE PLATE (LEXAN)
32	609253	CABLE ASSY - ANTENNA IN (SENSOR)	71	3395632	DECAL - CANNON LARGE TS [2.EA]	110	2267002	>SWIVEL PLATE (LEXAN)
33	1234002	INSERT - 1/4" PRESS THD #6-32	72	3991903	BAG ASSY - REAR ROD HOLDER TS	111	2267006	>INDEXING PLATE (TAPPED)
34	603103	SCREW - MACH #6-32 x 3/8" SS	73	0290796	>TUBE - ROD HOLDER	112	2277001	>NUT - RETAINER RELEASE
35	050265	CONTROL BOARD - MAG 20 DT	74	2151726	>WASHER - 5/16" FLAT	113	2287002	>SPRING - RELEASE PIN
36	1296831	WIRE - CIRCUIT BREAKER JUMPER (RED)	75	2383106	>NUT - 5/16"-18 SS	114	2372100	>SCREW - #8 x 5/8" PPHMS [2.EA]
37	3398205	CIRCUIT BREAKER - 30 AMP	76	3319005	>CLAMP - ROD HOLDER w/ SLOT	115	3392600	>RELEASE PIN
38	1221490	UP/DN SWITCH BOOT	77	3325002	>DISK - ROD HOLDER	116	9010004	>BEARING - SWIVEL BASE [2.EA]
39	1221491	CIRCUIT BREAKER BOOT	78	9040310	>BOLT - HEX 5/16"-18 x 2"	117	2200107	OFFSHORE STACKER

> PART OF ASSEMBLY

▶ ITEM CANNOT BE SOLD SEPARATELY

\* PARTS USED BUT NOT SHOWN

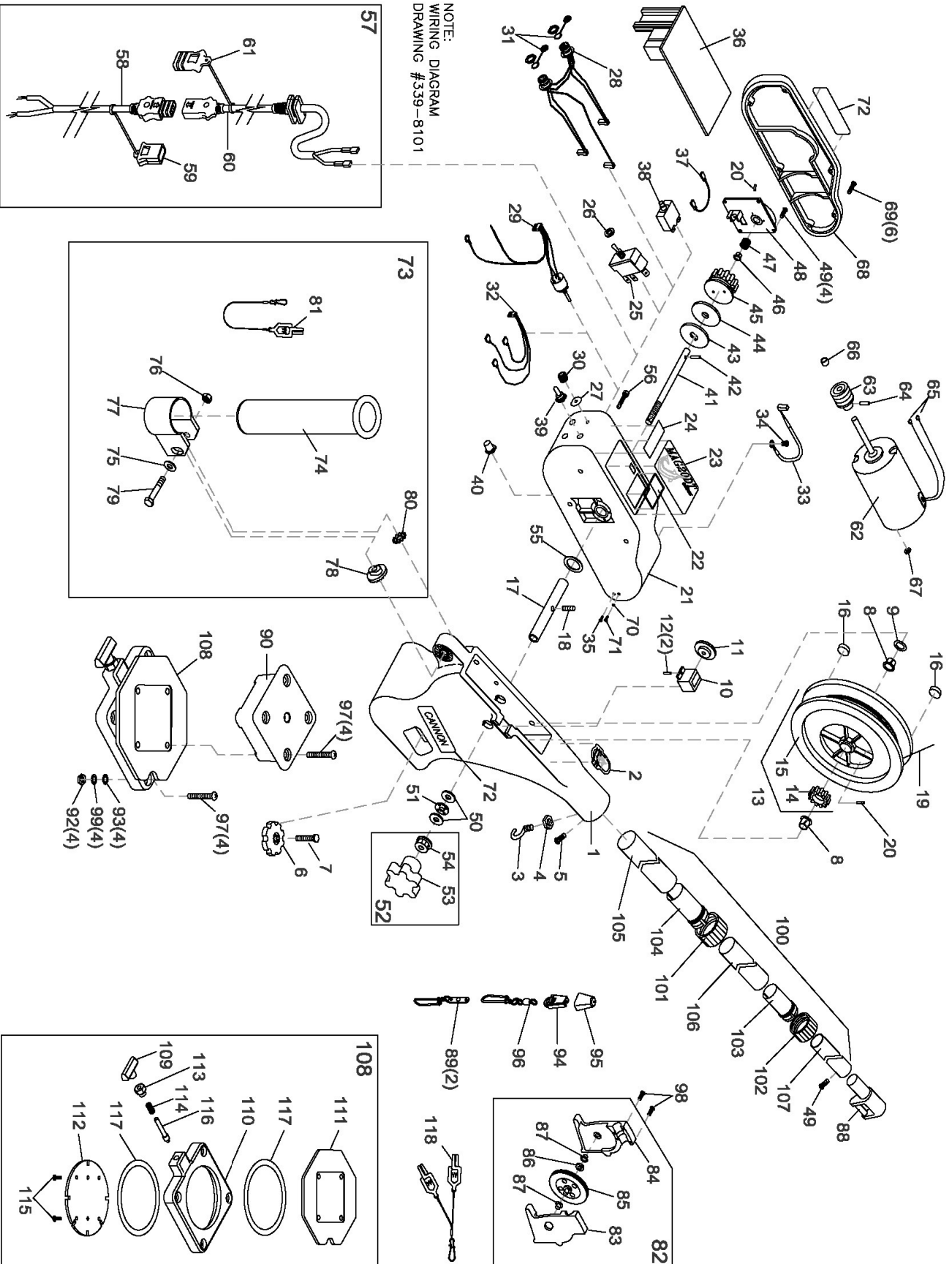

NOTE:  
WIRING DIAGRAM  
DRAWING #339-8101

In the U.S.A., replacement parts may be ordered directly from CANNON Parts Dept., 121 Power Drive, Mankato, Minnesota 56001. In Canada, parts may be ordered from any of the Canadian Authorized Service Centers shown on the enclosed list. Be sure to provide the MODEL and SERIAL numbers of your downligger when ordering parts. Please use the correct part numbers from the parts list. Payment for any parts ordered from the CANNON parts department, may be by cash, personal check, Discover Card, MasterCard or VISA. To order, call 1-800-227-6433 or FAX 1-800-527-4464.

1	3392505	FRAME - LARGE WHITE (LEXAN)	41	1480070	SHAFT - DRIVE	81	2200109	>OFFSHORE SALTWATER RELEASE
2	4427005	NOSE DECAL MAGNUM	42	9250002	PIN - DRIVE SHAFT 3/16" ROLL SS	82	3992300	SWIVEL HEAD ASSEMBLY
3	9040040	HOOK - 1/4" - 20 ROLLED	43	0467695	BRAKE PLATE - REEL	83	0267001	▶SIDE PLATE (RH)
4	2263102	NUT - HEX 1/4"-20	44	1264670	CLUTCH PAD	84	0267002	▶SIDE PLATE (LH)
5	9280750	SCREW - 1/4" - 20 (RH) X 3/4" PPH	45	1433074	GEAR - DRIVER WORM	85	0269726	▶PULLY - SWIVEL HEAD
6	0849615	BASE LOCK KNOB	46	9010003	BEARING - DRIVE SHAFT NYLINER	86	3397300	▶WASHER - .735 OD X .36 ID
7	9040340	BOLT - 3/8"-16 X 1-1/2" HEX	47	9400005	SPRING - SHAFT CONTACT	87	9010070	▶HDW BEARING BRASS(2 EA)
8	9010001	BEARING - REEL SHAFT NYLINER [2EA]	48	4421002	COVER - GEAR CASE	88	2227820	BOOM END - TELESCOPIC (LEXAN)
9	9430210	WASHER - 1-1/16" OD X 7/8" ID (NYLON)	49	2372100	SCREW - #8 X 5/8" PPHMS [5 EA]	89	2200148	SNAP & INSULATOR [2 EA]
10	3320011	DEPTH COUNTER - 3 DIGIT (METRIC)	50	9010310	WASHER - THRUST [2EA]	90	1007334	MOUNTING BASE (LEXAN)
11	3333010	COUNTER GEAR (METRIC)	51	9010280	BEARING - THRUST	91	2994893	*BAG ASSEMBLY, MOUNTING (KIT #3)
12	0854654	COUNTER CUSHION/STOPPER [2 EA]	52	2998906	KNOB BRAKE	92	2263102	NUT - HEX 1/4"-20 [4 EA]
13	3397916	REEL ASSEMBLY - TS ELECTRIC (METRIC)	53	0649001	▶KNOB - HAND ADJUST	93	2371712	WASHER - 9/32" FLAT [4 EA]
14	3333011	>GEAR REEL (METRIC)	54	9130390	▶NUT - KNURLED INSERT 3/8"-24	94	9100100	TERMINATOR
15	3397902	▶REEL - 3.75" SS	55	1479070	O-RING - REEL SHAFT	95	9100101	TERMINATOR CUSHION
16	1459666	REEL MAGNET [2 EA]	56	9370205	SCREW - 1/4" X 3/4" HEX WASH HD [3 EA]	96	9100620	TERMINATOR SNAP & SWIVEL
17	1480071	SHAFT - REEL	57	3993200	POWER CABLE ASSEMBLY	97	9280725	BOLT - TRUSS 1/4" - 20 X 2-1/2" [8 EA]
18	9340131	SCREW - SET 5/16"-18 X 1-3/4" (REEL)	58	3393200	>POWER CABLE - BATTERY	98	9370010	SCREW - #4 X 1/2" PPH [3 EA]
19	3775397	SPOOL CABLE SS [400.FT]	59	3393201	>CAP - POWER CABLE - BATTERY	99	9950357	WASHER - LOCK 1/4" SPLIT [4 EA]
20	9100070	CABLE LEADER SLEEVE [2 EA]	60	3393202	>POWER CABLE - MOTOR	100	3392010	TELESCOPIC BOOM SS
21	3396534	MOTOR HOUSING - MAG 20 TS (LEXAN)	61	3393210	>CAP - POWER CABLE - MOTOR	101	2219822	>BASE TUBE CLAMP
22	1497071	LENS - WINDOW DISPLAY	62	1458001	MOTOR 12V DC	102	2219823	>MID TUBE CLAMP
23	3395601	DECAL - LARGE, MAG 20 DTTTS	63	1497070	GEAR - WORM MOTOR	103	2222825	>MID TUBE COLLET
24	3395700	DECAL - POSITIVE ION CONTROL TS	64	9250001	PIN - MOTOR, 3/32" X 3/4" ROLL SS	104	2222826	>BASE TUBE COLLET
25	2286792	SWITCH - UP/DN CONTROL	65	700032	TERMINAL - MOTOR, FEM 12-10 [2EA]	105	3392001	▶BOOM BASE TUBE (SS)
26	2286793	WASHER - SHIM .750 X .1 UP/DN SWITCH	66	9010002	BEARING - MOTOR SHAFT	106	3392002	▶BOOM MID TUBE (SS)
27	3395701	DECAL - PIC KNOB DIAL TS	67	2263112	NUT - HEX #10-32 BZ	107	3392003	▶BOOM END TUBE (SS)
28	050268	CABLE ASSY - MAG20DT (DATA IN/OUT)	68	3390201	COVER - MOTOR HOUSING TS (LEXAN)	108	2998905	SWIVEL BASE
29	050215	POSITIVE ION CONTROL POT	69	3393400	SCREW - #8-18 X 1-1/4" PPHMS SS [6 EA]	109	2249001	>KNOB - RELEASE PIN (LEXAN)
30	611005	KNOB - POSITIVE ION CONTROL	70	701007	O-RING - SMALL	110	2267001	>BASE PLATE (LEXAN)
31	700176	CAP - CONNECTION PORT [2 EA]	71	2332103	SCREW-#6-20 X 3/8"	111	2267002	>SWIVEL PLATE (LEXAN)
32	609209	CABLE ASSY - MAG20DT UP/DN SWITCH	72	3395632	DECAL - CANNON LARGE TS [2 EA]	112	2267006	>INDEXING PLATE (TAPPED)
33	609253	CABLE ASSY - ANTIENNA IN (SENSOR)	73	3991903	BAG ASSY - REAR ROD HOLDER TS	113	2277001	>NUT - RETAINER RELEASE
34	1234002	INSERT - 1/4" PRESS THD #6-32	74	0290796	>TUBE - ROD HOLDER	114	2287002	>SPRING - RELEASE PIN
35	603103	SCREW - MACH #6-32 X 3/8" SS	75	2151726	>WASHER - 5/16" FLAT	115	2372100	>SCREW - #8 X 5/8" PPHMS [2 EA]
36	050265	CONTROL BOARD - MAG 20 DT	76	2383106	>NUT - 5/16"-18 SS	116	3392600	>RELEASE PIN
37	1296831	WIRE - CIRCUIT BREAKER JUMPER (RED)	77	3319005	>CLAMP - ROD HOLDER W/ SLOT	117	9010004	>BEARING - SWIVEL BASE [2 EA]
38	3398205	CIRCUIT BREAKER - 30 AMP	78	3325002	>DISK - ROD HOLDER	118	2200107	OFFSHORE STACKER
39	1221490	UP/DN SWITCH BOOT	79	9040310	>BOLT - HEX 5/16"-18 X 2"			
40	1221491	CIRCUIT BREAKER BOOT	80	9430160	>WASHER - STAR 5/16"			

> PART OF ASSEMBLY

▶ ITEM CANNOT BE SOLD SEPARATELY

\* PARTS USED BUT NOT SHOWN

## Free Manuals Download Website

<http://myh66.com>

<http://usermanuals.us>

<http://www.somanuals.com>

<http://www.4manuals.cc>

<http://www.manual-lib.com>

<http://www.404manual.com>

<http://www.luxmanual.com>

<http://aubethermostatmanual.com>

Golf course search by state

<http://golfingnear.com>

Email search by domain

<http://emailbydomain.com>

Auto manuals search

<http://auto.somanuals.com>

TV manuals search

<http://tv.somanuals.com>