

Canon

CARD PHOTO PRINTER **CP-100**

Canon Card Photo Printer

User Guide

ENGLISH

Foto-impresora Canon para
tamaño tarjeta

Guía del usuario

ESPAÑOL

Imprimante photo Canon

Guide d'utilisation

FRANÇAIS

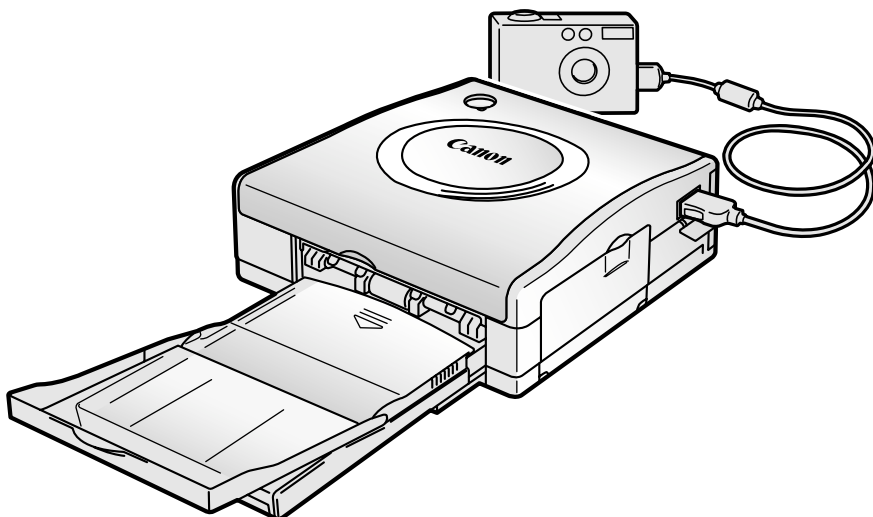

TM
DPOF

**DIRECT
PRINT**

Contents

Quick Start Guide	2
Introduction	4
Features	5
Read This First	6
Package Contents	6
Safety Precautions	8
Proper Usage and Handling	11
Components Guide	15
Let's Print	16
Checking Your Ink/Paper Sets	16
Loading the Ink Cassette	18
Placing the Paper into the Paper Cassette	19
Loading the Paper Cassette	20
Connecting the Printer to a Power Source	21
Connecting the Camera to the Printer	22
Printing	23
Using the Battery/Charge Adapter Kit BCA-CP100 (Optional) ..	24
Charging the Battery Pack NB-CP1L	24
Installing the Battery Pack NB-CP1L	26
Using the Car Battery Adapter CBA-CP100 (Optional)	28
Troubleshooting	29
Error Messages	31
Specifications	34

Quick Start Guide

This section explains the procedures required to print images on postcard size paper, using the ink cassette, the paper cassette and the paper included in your kit. When using the optional Color Ink/Paper (label) set, refer to *Let's Print*. → p. 16

1

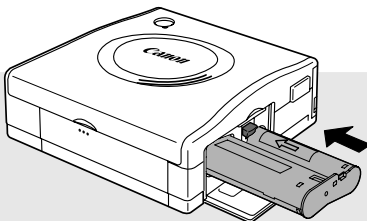

Loading the Ink Cassette → p. 18

Insert the supplied ink cassette (Postcard size) in the printer.

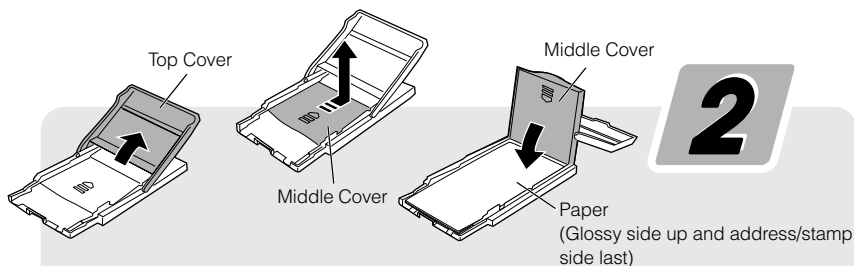

Placing the Paper into the Paper Cassette → p. 19

Place the supplied standard paper (Postcard size, 5 sheets) in the paper cassette.

3

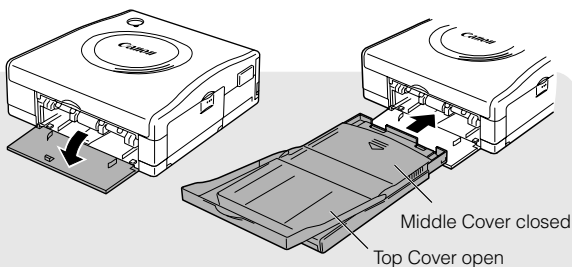

Loading the Paper Cassette → p. 20

Push the paper cassette all the way into the paper cassette slot.

4

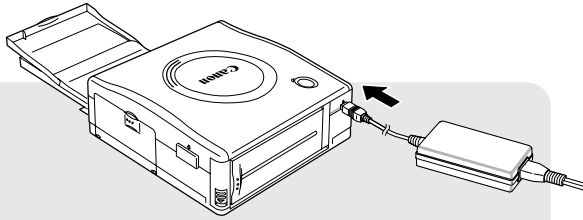

Connecting the Printer to a Power Source → p. 21

Place the printer on a level surface and connect the compact power adapter.

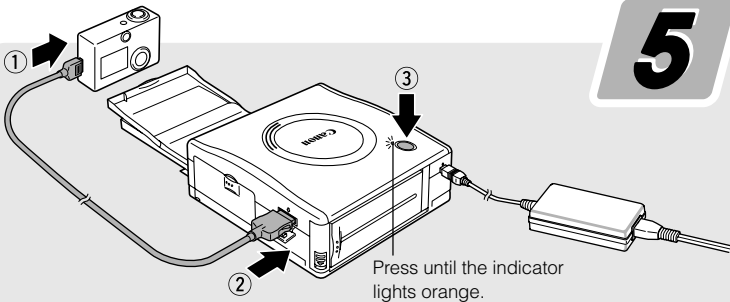

Connecting the Camera to the Printer → p. 22

Connect the camera to the printer using the direct interface cable and press the ON/OFF button.

6



e.g. PowerShot S200 DIGITAL ELPH/
DIGITAL IXUS v²

Printing → p. 23

Set the camera to replay mode and turn the power on. Display the image you wish to print and select [Print] or [OK].

Introduction

Thank you for your purchase of the Canon Card Photo Printer CP-100.

This *User Guide* explains the printer's general flow of operations, from print settings to printing. For information about how to make prints, refer to the *Camera User Guide* that came with your camera.

Before using your printer for the first time, please read through the safety precautions. (→ p. 8)

Warning Against Copyright Infringement

Please respect all copyrights. Use of images produced by this printer for purposes other than personal entertainment may be prohibited by law. The taking of photographs at performances, trade shows, exhibitions, and other such venues may be subject to restrictions regardless of intended use.

Warranty Limitations

This printer's warranty is only effective in the country of sale. If a problem arises while the printer is in use abroad, please convey it back to the country of sale before proceeding with a warranty claim to a Canon Customer Support Help Desk.

For Canon Customer Support contacts, please see the Canon Limited Warranty supplied with your printer.

Disclaimer

- While every effort has been made to ensure that the information contained in this User Guide is accurate and complete, no liability can be accepted for any errors or omissions. Canon reserves the right to change the specifications of the hardware and software described herein at any time without prior notice.
- No part of this User Guide may be reproduced, transmitted, transcribed, stored in a retrieval system, or translated into any language in any form, by any means, without the prior written permission of Canon.
- Canon makes no warranties for damages resulting from corrupted or lost data due to a mistaken operation or malfunction of the product, the CompactFlash™ cards (CF cards) or use of non-Canon CF cards.

Trademark Acknowledgements

- Canon is a trademark of Canon, Inc.
- Any other company and product names used herein may be trademarks of their respective companies.

Features

Connects directly to supporting Canon cameras

Allows easy printing from any Canon camera that supports direct printing. Just connect the interface cable and you're ready to go.

Three paper sizes

You can print on standard paper in postcard size, L size or credit-card size.

Two types of labels (credit-card size)

In addition to the standard size paper, you can print full-sized labels or 8-label stickers with the credit-card size paper.

High-quality prints, fast feeding of the paper

Offers photo-quality prints. Produces up to 18 prints without reloading.

Fast printing

Postcard size images can be printed at the high speed of 81 seconds per sheet.

Coated prints

Applies a protective coating to each print.

Borderless prints

Can produce borderless images that fill the paper completely.

Supports DPOF (Digital Print Order Format)

Supports DPOF settings for print selection, number of copies, and shooting date.

Easy outdoor printing

You can easily print outdoors by attaching the Battery Pack (optional) to the printer. The Car Battery Adapter (optional) can also be used as a power source.



- If  does not display on the camera's LCD monitor when you connect your camera to this printer, your camera's firmware may be incompatible with this printer. Please check the Canon BeBit website (<http://www.canon.co.jp/Imaging/BeBit-e.html>) or your regional Canon website, for information or to download compatible firmware.

Read This First

Package Contents

Card Photo Printer CP-100

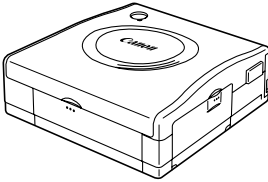

Paper Cassette
(Postcard size)

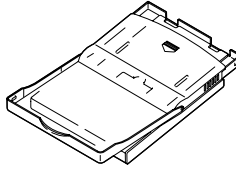

Paper Cassette
(Card size)

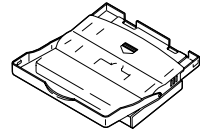

Standard Paper
(Postcard size, 5 sheets)

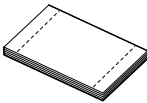

Direct Interface Cable DIF-100

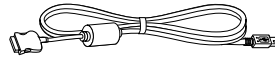

Ink Cassette (Postcard size)

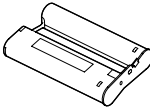

Direct Interface Cable DIF-200

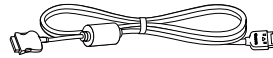

Compact Power Adapter
CA-CP100

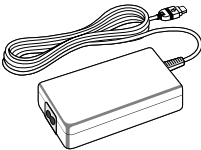

AC Cable

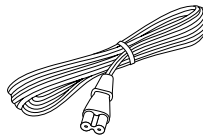

Cleaner Stick

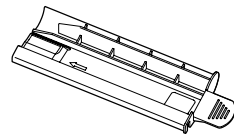

User Guide (this booklet)
*Warranty Card**
*Canon Customer Support Leaflet**
* Not included in some regions.

- For information about which direct interface cable** should be used on your camera, refer to the *Camera User Guide*.

** Direct interface cable is used to connect the camera to the printer.

The following products are sold separately.

- Paper Cassette PCL-CP100 (L size)*
- Color Ink/Paper Set KP-36IP
(Postcard size, 36 standard sheets)
- Color Ink/Paper Set KL-36IP*
(L size, 36 standard sheets)
- Color Ink/Paper Set KC-36IP
(Card size, 36 standard sheets)
- Color Ink/Full-sized Label Set KC-18IF
(Card size, Full-size, 18 Label sheets)
- Color Ink/Label Set KC-18IL
(Card size, Multiple (8-screen), 18 Label sheets)

- Battery Pack NB-CP1L
- Battery/Charge Adapter Kit BCA-CP100
- Car Battery Adapter CBA-CP100

* Not sold in some regions.

Safety Precautions

- Before using the devices, please ensure that you have read and understood the safety precautions described below. Always ensure that the devices are operated correctly.
- The safety precautions noted on the following pages are intended to instruct you in the safe and correct operation of the devices to prevent injuries or damage to yourself and other persons.
- “Devices” refers to the “printer, compact power adapter, battery pack (optional) or charge adapter (optional)” throughout this guide.

WARNINGS

Devices

If the devices emit smoke or a burning odor, or show other signs of significant malfunction, immediately unplug the AC cable from the electrical outlet. Continued operation under these conditions poses risk of fire or electric shock. Be sure that smoke or burning odor subsides, and then contact your dealer or the nearest Canon Customer Support help desk.

If the devices are dropped or the devices casing becomes damaged, unplug the AC cable from the electrical outlet. Continued operation poses risk of fire or electric shock. Contact your dealer or the nearest Canon Customer Support help desk.

Never rest small metallic objects or liquid containers on top of the devices. If liquid splashes onto the devices, wipe the devices dry using a soft absorbent cloth. If liquid spills into the devices or an object falls into the devices, immediately unplug the AC cable from the electrical outlet. Continued operation poses risk of fire or electric shock. Contact your dealer or the nearest Canon Customer Support help desk.

Do not use flammable solvents such as alcohol, benzene, or paint thinner to clean the devices. Use of such solvents poses a fire risk.

Do not drop or insert metallic or combustible objects into the devices. Entry of foreign objects into the devices may result in fire, electric shock, or equipment failure. Store the devices out of the reach of children.

Do not disassemble or modify the devices. The devices contain high-voltage components, and there is risk of electric shock. If your devices need internal adjustment or repair, contact your dealer or a Canon Customer Support help desk.

Do not touch metal parts of the devices or the power plug during thunderstorms. Lightning strikes may produce lethal voltages within the devices. Keep clear of the devices while thunderstorms are in progress.

Power

Do not exceed the cable and power outlet ratings when operating this product. Do not operate this product outside of the specified voltage rating.

Connecting too many lines to the same outlet may result in fire. Check that the voltage of the outlet is compatible with the devices before them in.

If the AC cable becomes damaged (if internal wiring is exposed, etc.), immediately unplug the cable from the electrical outlet. Continued use poses risk of fire or electric shock.

Do not plug in or unplug the AC cable while your hands are wet, as this may result in electric shock. When unplugging the cable, hold it firmly at the plug area. Do not pull directly on the cable, as this may damage or expose the cable's internal wiring, resulting in risk of fire or electric shock.

Be sure that the AC cable is plugged all the way in. A loose connection may result in heat buildup, fire, or electric shock.

Do not damage, modify, or rest heavy objects on the AC cable. Damage to the cable may result in the exposure of live wires, fire, or electric shock.

Keep the AC cable free of dust. The presence of dust or metallic debris on the plug poses risk of fire or electric shock. If the plug area is not clean, unplug the AC cable and then wipe the plug area clean using a dry cloth. Check the plug periodically to make sure it is clean.

Usage Location

Do not place the devices on an unstable or tilted table or desk, as there is risk that the devices may fall and cause injury.

CAUTIONS

Devices

Do not block the air vents on the printer. Blocking the vents may cause the inside of the printer to overheat, resulting in damage to internal components and risk of equipment failure or fire. Use the devices in a well-ventilated area.

Do not rest heavy objects on the devices. Objects may fall off the devices and cause injury. Weight placed on the devices may deform the casing, resulting in damage to internal parts and posing risk of fire.

Unplug the devices when you are not using them. If the devices remain plugged in, there is risk that accidental contact with the device's internal parts may cause electric shock. Leaving the devices plugged in during prolonged periods of non-use poses risk of fire.

Do not remove the paper cassette from the printer while printing is in progress. Paper moves back and forth in the cassette four times during printing. Placing your hand in the way of moving paper may result in injury. Wait for printing to finish completely before removing the cassette. Never place your hand into the paper cassette slot.

Do not reach into internal parts of the devices except as specified in the operating instructions. Reaching into inappropriate parts of the devices may cause your hand to become caught or injured.

Power

Do not move the devices while they are plugged in. Doing so may damage the AC cable. Continued use of a damaged AC cable poses risk of fire or electric shock.

Do not excessively bend or twist the AC cable. Doing so may damage the cable. Continued use of a damaged cable poses risk of fire or equipment failure. Leave about 10 cm (4 in.) of clearance around the devices to ensure adequate ventilation.

Do not pull on the AC cable. Doing so may damage the cable. Continued use of a damaged cable poses risk of fire or electric shock. Always hold the cable by the plug area when unplugging it.

Usage Location

Do not use the devices in locations that are smoky, humid, dusty, or subject to strong vibration. Entry of water or dust into the devices, or internal damage caused by strong vibration, may pose risk of fire or electric shock. Have the devices checked approximately once a year (contact your dealer), preferably before the onset of the your area's humid season.

Do not leave the devices exposed to high temperatures. Do not leave in direct sunlight, or close to heating equipment, or in a car with windows closed on a hot day. High temperatures may cause deformation of the devices and pose risk of fire.

Do not use the devices near an open flame. Sheets ejected from the printer (onto the top of the paper cassette) may fall into the flame, resulting in fire.

Do not use the devices close to TV sets or AM radios. Devices' operation may adversely affect TV and radio reception.

Proper Usage and Handling

Usage Location

- Do not use near strong magnets or near devices that produce strong electromagnetic fields.
Electromagnetic radiation from devices such as TVs and game machines, and strong magnetic fields from devices such as speakers and large motors, may cause distortion in printed images.
- Use in a well-ventilated, level area.
- Leave about 10 cm (4 in.) of clearance around the printer. Be sure to leave clearance around the paper handling slot (at the rear) so that paper has sufficient room to jut out from the slot during printing.

Handling Precautions

- Please avoid turning the printer's power on and off needlessly as the printer initialization consumes ink: There may not be enough ink left for the allotted sheets in the set.
- Never use volatile compounds or insecticides on the printer, and do not allow rubber or vinyl material to remain in prolonged contact with the printer. These materials may cause deformation of the printer's casing.
- Unplug the printer when you are not using it.
But please note that you should plug in and run the printer at least once every six months to ensure that it remains functional.
- Before transporting the printer, remove the paper and ink cassettes and close the paper cassette cover and the ink cassette cover.
- Pack the printer into an appropriate case for transport.
If a case is not available, wrap it with cloth or other protective material to protect against scratches.

Overheating

If the printer overheats, it will temporarily stop operating. *This does not mean that the printer has malfunctioned.* The printer will resume normal printing as soon as it cools down.

Temporary stoppages are most likely to occur in the following cases:

- When printing continuously.
- If the room is unusually warm.
- If the air vents are blocked or if ventilation is inadequate.

To Prevent Damage from Condensation

Condensation may form in the printer if you suddenly move it from a cold location to a warm location. To prevent damage that might be caused by condensation, place the printer in a sealed vinyl bag prior to moving it, and allow it to reach room temperature before using it.

Cleaning the Printer

- Never use benzene, paint thinner, or other volatile solvents to clean the printer. Volatile solvents may cause deformation or peeling of the printer's casing. To clean the printer, wipe it with a soft dry cloth. If stronger cleaning is required, wipe first with a cloth moistened with a dilute neutral solvent, then wipe again with a soft dry cloth. If you use a chemical cleaning cloth, read the instructions that come with it and observe all indicated precautions.
- Keep the air vents clean and free of dust.
Clean the vents as necessary. Dust that enters the printer through the vents may land on the ink sheet, resulting in poor print quality and possibly leading to printer breakdown. If the ink sheet becomes dusty, remove the ink cassette and replace it with a new one.

Proper Handling of Ink Cassettes, Paper Cassettes, and Paper

- Please use only the ink cassettes and paper types specified for use by Canon.
- Allow ink cassettes and paper to reach room temperature before installing and using them.
Condensation may form if you suddenly move ink cassettes or paper from a cold location to a warm location. If there is risk of condensation, leave the cassette and paper in their packaging until they reach room temperature, and wipe away any moisture before loading them.
- Do not place any foreign objects in the print output receptacle (on the top of the paper cassette). This area is for paper only.
- Remember to remove the slack from the ink sheet before installing the ink cassette.
To take up the slack, push in the blue circle and turn it in the direction of the arrow embossed on the top of the cassette.

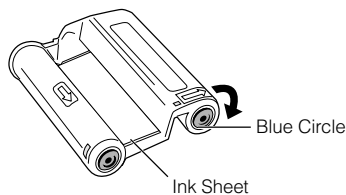

- Do not touch or pull on the ink sheet.
- Do not tear or bend the paper's perforated edges before printing.
- Do not use label sheets on which labels are partially peeled off.
- Paper must be printed on the glossy side (the side without any printed markings). Always load paper into the cassette with the glossy side up. Loading the paper the wrong way may result in poor print quality, and in some cases may cause damage to the printer.
- Do not write on the paper before printing.
Writing on paper before printing on it may result in malfunction.

- You may write on the back of the paper with an oil-based pen, but to avoid smudging please allow ink time to dry before touching it.
- Do not overload the paper cassette.
Do not insert more than 18 sheets in the paper cassette. Overloading the cassette may damage the printer.
- Do not open the ink cassette cover while printing is in progress, and do not pull the ink cassette out. These actions may damage the printer.
- Do not apply excessive force to the paper cassette.
Force or impact on the cassette may result in paper jams or equipment damage.
- Do not bend or deform the spring located at the rear of the middle cover of the paper cassette.

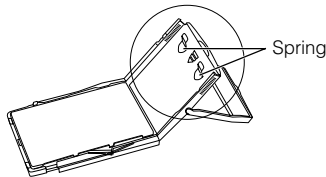

- Do not allow too many prints to accumulate in the print output receptacle. Do not allow more than 9 sheets to accumulate in the print output receptacle.
- Do not touch paper while it is being printed. During printing, the sheet repeatedly moves back and forth along the top of the paper cassette and in and out through the paper handling slot. Please do not touch the sheet during this process.

Maintaining the Quality of Your Prints

- Do not touch the print side of the paper with your fingers. Always hold the paper along the edges (outside the perforated border). Be sure that hands are dry before touching the paper, and do not scratch on the paper surface with a hard object. Keep the paper surface away from dust, water droplets, etc.

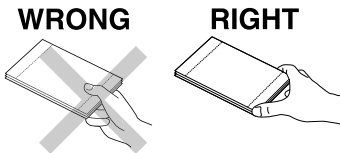

- Do not stick any type of adhesive tape onto the print surface.
- Do not allow print surfaces to come into contact with vinyl materials.
Keep the print surface away from vinyl desk blotters, vinyl wallets and name-card cases, plastic erasers, etc.
- Do not apply alcohol or other volatile solvents to the print surface.
Contact with volatile solvents may cause color loss or color change.
- Do not leave print surfaces tightly pressed against any other surfaces or objects for prolonged periods.
Prolonged contact may cause color bleeding.

- Do not store prints in hot, humid, or dusty locations or where exposed to direct sunlight.
- Color change may occur over time in accordance with conditions of storage. Canon assumes no liability for color changes.
- If you wish to mount prints into an album, select an album with nylon-based sleeves, or with propylene or cellophane sleeves. Other types of sleeves may cause color loss or color bleeding.

Storage

- Do not store in locations that are humid or dusty or that reach temperatures above 40°C (104°F), or where exposed to direct sunlight. Inappropriate storage may impair the print quality.
- Remove unused paper from the paper cassette, return it to its original package, and store the package horizontally.
- If you are not planning to use the printer for a while, remove the ink cassette and paper cassette. Close the paper cassette's upper cover.

Others

- When opening a color ink/paper set (full-sized label set, label set), check the contents. If something seems to be missing or appears to be damaged, contact the dealer for assistance.
- Charge the battery pack using the compact power adapter supplied with the printer.
- When using the battery pack (optional), if the battery status is low, the finished print may not be ejected into the print output receptacle completely. If this happens, please pull out the paper.

Components Guide

Indicator

Indicates the printer's status.

- Orange: Starting-up
- Green: Ready to print
- Flashing green: Printing in progress
- Flashing orange: Low battery
- Red/Flashing red: Error

ON/OFF Button

Turns the printer's power ON and OFF.

DIGITAL Terminal

For direct connection to a camera using the direct interface cable.

Ink Cassette Slot

The ink cassette loads into this compartment.

Ink Cassette Compartment Cover

Paper Cassette Slot

The paper cassette loads into this slot.

Paper Cassette Compartment Cover

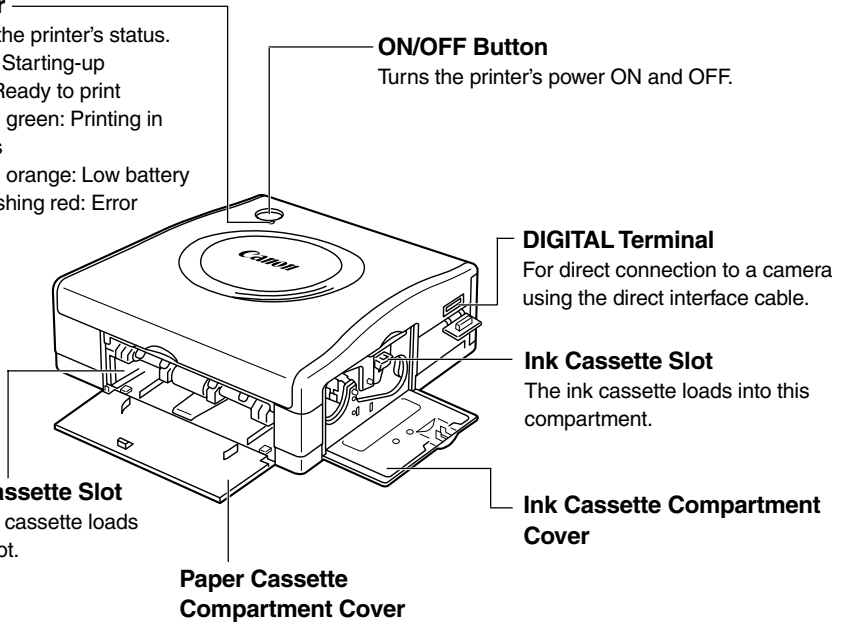

Air Vents

DC IN Terminal

Connects to the Compact Power Adapter.

Paper Handling Slot

Paper extends out from this slot while printing is in progress.

Battery Cover Lever



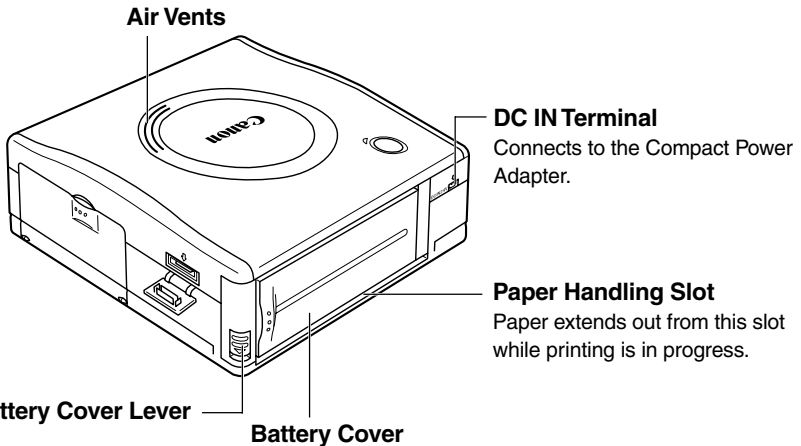



Battery Cover

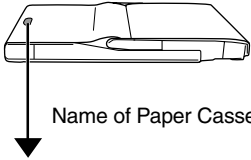
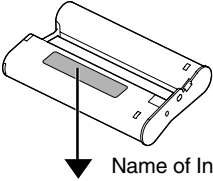

Checking Your Ink/Paper Sets

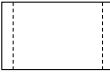
When printing with the Canon Card Photo Printer CP-100, please make sure you are using the right ink cassette, paper cassette and paper. If the set is not correct you will not be able to print.

Please check the sets and the names of their components (ink cassette, paper cassette and type of paper) in the table below.

Paper Cassette / Paper		Ink Cassette
 <p>Name of Paper Cassette</p>		 <p>Name of Ink Cassette</p>
POSTCARD SIZE	 Standard Paper (Postcard size)	Canon Color Ink Cassette (for 5 Printouts) Postcard (4×6in) size
	 Standard Paper (Postcard size)	Canon Color Ink Cassette (for 36 Printouts) Postcard (4×6in) size
L SIZE	 Standard Paper (L size)	Canon Color Ink Cassette (for 36 Printouts) L size
CARD SIZE	 Standard Paper (Card size)	Canon Color Ink Cassette (for 36 Printouts) Card size
	 Full-sized Label (Card size)	Canon Color Ink Cassette (for 18 Printouts) Card size
	 8-sticker Label (Card size)	

 Included in package

You can use the following Color Ink/Paper Set (optional) with the Canon Card Photo Printer CP-100.

- Color Ink/Paper Set KP-36IP
(Postcard size, 36 standard sheets)



- Color Ink/Paper Set KL-36IP
(L size, 36 standard sheets)

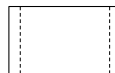

- Color Ink/Paper Set KC-36IP
(Card size, 36 standard sheets)



- Color Ink/Full-Sized Label Set KC-18IF
(Card size, Full-size, 18 Label sheets)



- Color Ink/Label Set KC-18IL
(Card size, Multiple (8-screen), 18 Label sheets)



- The paper cassette PCL-CP100 (optional) is requested to print on L size paper.



- For best results, use the ink cassette together with the paper that it came with. (The cassette's ink sheet is just long enough to print to all of the paper included in the ink/paper set.)

Loading the Ink Cassette

1

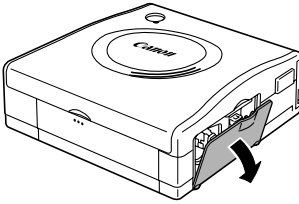

Open the ink cassette compartment cover.

2

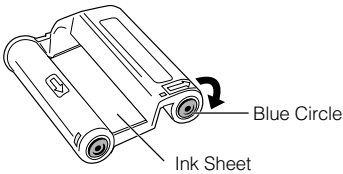

Remove any slack from the ink sheet.

- Push in on the blue circle on the cassette, and turn it in the indicated direction to take up the slack.

3

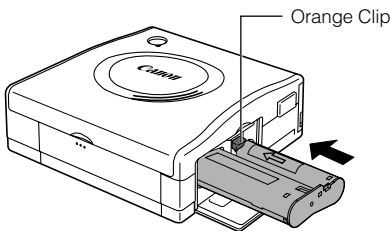

Hold the cassette so that the embossed arrow is at the top, and insert it all the way into the compartment (in the direction of the arrow).

- Be careful to avoid touching or pulling on the ink sheet when inserting the cassette.
- Push the cassette all the way in, so that it clicks into place.
- When you are ready to remove the ink cassette: Lift the orange clip and pull the cassette out.

4

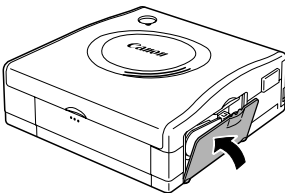

Close the ink cassette compartment cover.



- Do not reuse empty ink cassettes. Attempting to reuse an empty ink cassette may result in malfunction or damage to the printer.
- Please also refer to "Proper Usage and Handling" for advice about proper handling of ink cassettes. (→ p. 12)

Placing the Paper into the Paper Cassette

1

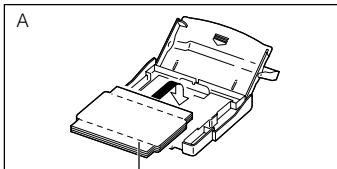
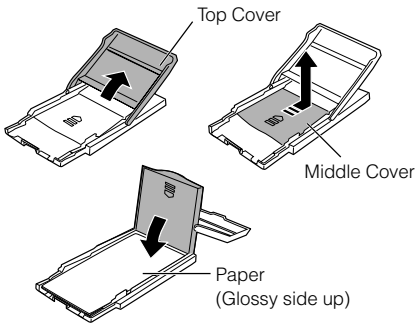

Credit-Card Size
(Standard Paper/Full-sized Label)

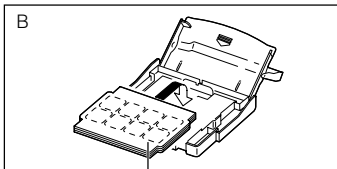

Credit-Card Size (8-label Sticker)

Place the paper into the paper cassette, with the printable side (glossy side) facing up.

- To open the paper cassette: Open the top cover, then push the middle cover in the direction of the arrow and lift it up.
- Insert the postcard size paper with the glossy side up and the address/stamp side last.
- After loading the paper, push the middle cover back toward its original position until it clicks into place. But leave the top cover open.
- Insert the credit-card size (standard paper/full-sized label) as shown in figure A.
- Insert the credit-card size (8-label sticker) as shown in figure B.



- Please use specified paper types only.
- Be sure to fan the paper stack (so that the sheets won't stick together) before loading the paper into the cassette.
- Do not insert more than 18 sheets in the paper cassette.
- Do not bend or tear off perforated edges on the paper prior to printing. Doing so may cause the part of the ink sheet to be wasted. (The ink sheet is just long enough to print to all of the paper in the ink/paper set. Wasting part of the ink sheet will cause it to run out too soon.)
- Never print on a sheet of paper more than once, even if the first printing has left the paper completely blank. The coating applied to the paper as it passes through the printer makes it unsuitable for further use. Reused paper may stick to the ink sheet, resulting in damage to the printer.
- Please also refer to "Proper Usage and Handling" for advice about proper paper handling. (→ p. 12)

Loading the Paper Cassette

1

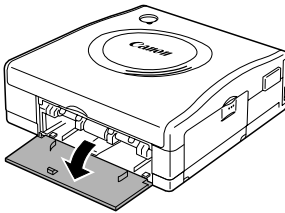

Open the paper cassette compartment cover.

2

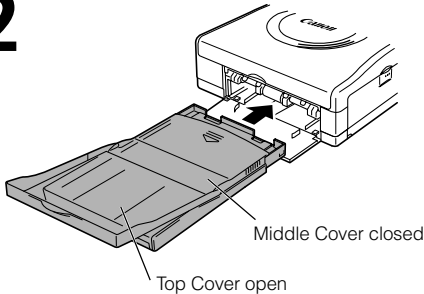

Push the paper cassette all the way into the paper cassette slot.

- Be sure the paper is set correctly before pushing the cassette in.
- Insert the paper cassette evenly so that it slides over the bottom of the slot entrance.



- The printer outputs the finished prints into the receptacle onto the top of the printer cassette (top of the middle cover or inside of the top cover). Be sure to close the middle cover and open the top cover so that output can proceed normally.



- Do not remove the paper cassette while feeding, printing, or ejection is in progress.

Connecting the Printer to a Power Source

1

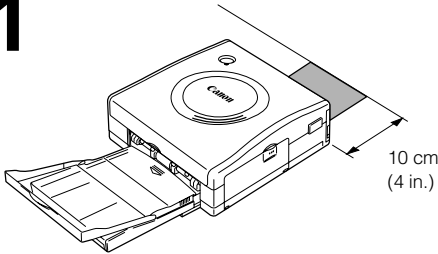

Place the printer on a flat area.

- Be sure to leave about 10 cm (4 in.) of clearance around the paper-handling slot (at the rear) so that paper has sufficient room to jut out from the slot during printing.
- Always check that nothing clogs up the paper-retrieving hole under the printer.

2

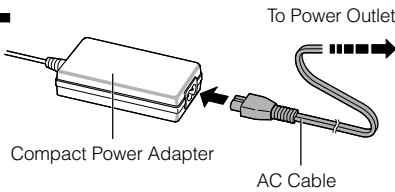

Connect the AC cable to the Compact Power Adapter CA-CP100 and insert the plug in a power outlet.

3

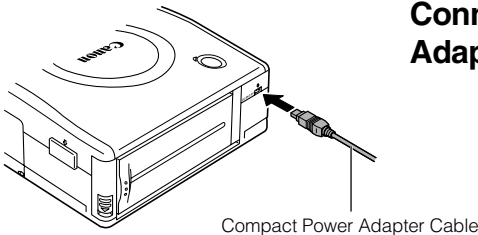

Connect the Compact Power Adapter cable to the printer.



- Please also refer to "Proper Usage and Handling" for advice about proper handling of printer. → p. 11

Connecting the Camera to the Printer

Connect the camera to the printer using the direct interface cable and turn the printer's power on. For more details on the direct interface cable or about camera connection instructions, refer to your *Camera User Guide*.

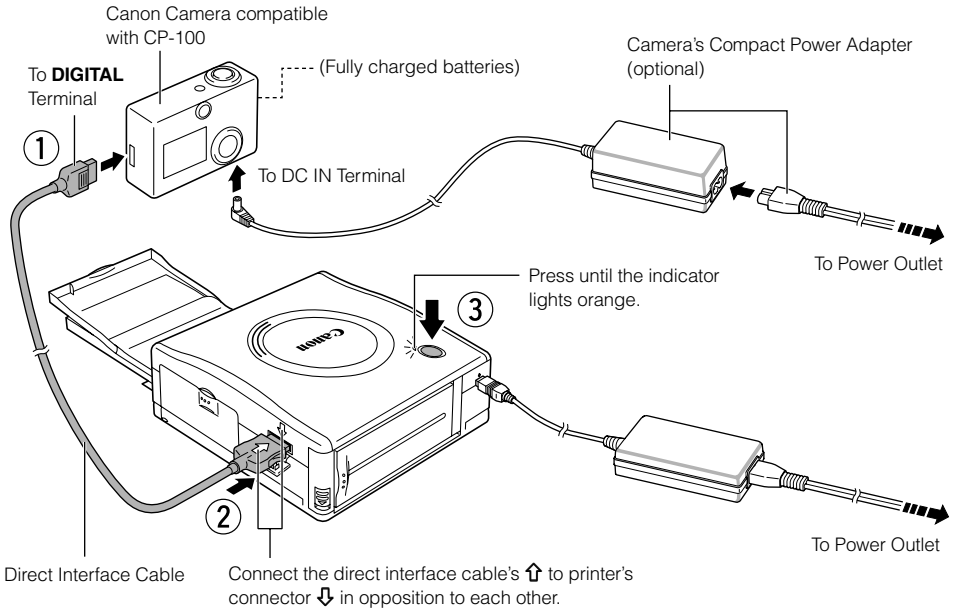

- When the power is turned on, the indicator will change from orange to green.



- We recommend that you connect the camera's (optional) compact power adapter when using the camera with your printer. If you wish to run the camera on battery power, be sure that batteries are fresh (fully charged).
- When connecting the direct interface cable, be sure that the connectors on the cable match up correctly with the connectors on the camera and printer.
- To shut the printer's power off, press the ON/OFF button until the indicator light turns off.
- Use an easily accessible power outlet for the printer's AC cable, so that you can unplug the printer cable quickly in the event of a problem.
- When disconnecting the direct interface cable, remove the connector by pressing both sides.

Printing

This section explains the flow of printing operations.
For more details, refer to your *Camera User Guide*.

1



Set the camera to replay mode and turn the power on.

- Check that  (Direct Print mark) is displayed in the upper left corner of the LCD monitor.



If does not display, check the following:

- Is the cable correctly connected? → p. 22
- Is the printer's power on? → p. 22
- Is your camera's firmware compatible with this printer? → p. 29

2

Display the images to be printed and press the SET button.

3

Select the number of images you wish to print and other settings.

4

Select [Print] or [OK] and press the SET button.

- The camera returns to the replay screen once printing is successfully completed.
- Do not put more than 9 sheets in the print output receptacle.



If printing doesn't start, check the following:

- Are the camera or the printer's batteries depleted?
→ We recommend that you use the compact power adapter or fully charged batteries.
- Are your paper and ink from the same type of set? → p. 16
- Does the camera's LCD monitor display a message? → p. 31

Using the Battery/Charge Adapter Kit BCA-CP100 (Optional)

Keep the battery pack, charge adapter and terminals clean at all times. Dirty terminals may cause a poor contact between the battery pack and printer. Polish the terminals with a tissue or a dry cloth before charging or using the battery pack.

Charging the Battery Pack NB-CP1L

1

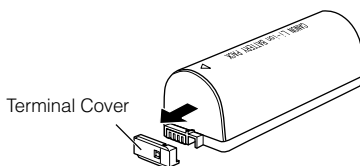

Remove the terminal cover.

2

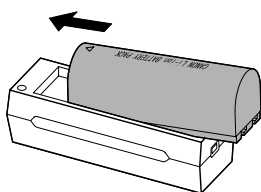

Attach the battery pack to the charge adapter.

- Attach it firmly in the direction of the arrow.

3

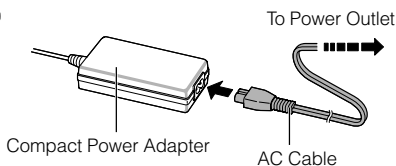

Attach the AC cable to the compact power adapter CA-CP100 and plug it into a power outlet.

- Charge the battery pack using the compact power adapter supplied with the printer.

4

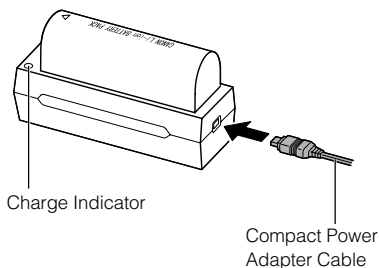

Connect the compact power adapter cable to the charge adapter.

- The charge indicator lights in orange while charging and in green once the battery pack is fully charged.
- Detach the battery pack from the charge adapter once charging is complete.



- The battery cannot be charged when connected to the printer. Please use the charge adapter to charge the battery pack.
- This is a lithium ion battery pack so there is no need to completely use or discharge it before recharging. It can be charged at any charge state.
- It takes approximately 150 minutes to bring a fully discharged battery pack to a full charge state (based on standard Canon testing criteria).
Charging times will vary according to the surrounding temperature and battery pack charge state.
- Charge it within a temperature range of 5 to 40°C (41 to 104°F).
- The charge adapter may emit noises while charging. This is not a malfunction.
- Do not cover the compact power adapter with anything, such as a tablecloth, cushion or blanket, when it is charging. Heat will build up internally and possibly lead to fire.
- Do not charge batteries other than Battery Pack NB-CP1L with the supplied equipment.
- The battery pack continues to discharge a small amount when left in the printer or charge adapter even with the power turned off. This shortens the battery life. Remove it from the printer and charge adapter, attach the supplied terminal cover and store it at room temperature (30°C/86°F or less) in a dry place.
- Charge it before use. Even charged battery packs continue to discharge naturally. You are advised to charge the battery on the day of use, or one day before, to ensure a full charge.
- Since storing a fully charged battery pack for long periods of time (about 1 year) can shorten its lifecycle or affect performance, you are recommended to use the battery pack in the printer and to store it at room temperature (30°C/86°F or less). If you do not use the battery pack for long periods of time, charge it fully and discharge it fully in the printer at least once a year before returning it to storage.



- Do not charge this battery pack with charge adapters other than those recommended by Canon.
- Do not charge the battery pack for more than 24 continuous hours to avoid performance loss.
- Do not carry or store the battery pack with metal objects with sharp edges, such as paper clips and pins. Always put the terminal cover on the battery pack's terminal when carrying it or before storing it.

Installing the Battery Pack NB-CP1L

1

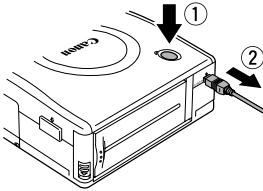

Turn the printer's power off and detach the compact power adapter cable.

2

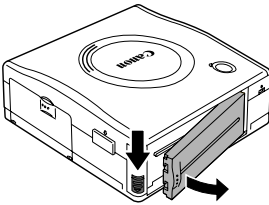

Press the battery cover lever down and remove the battery cover.

3

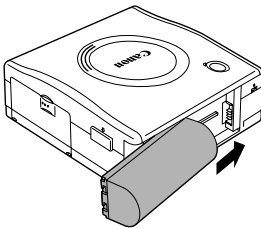

Slide the battery pack into place, in the direction of the arrow.

4

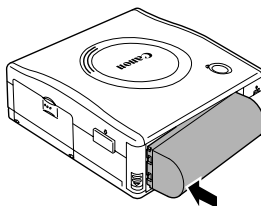

Push the battery pack in, until it clicks into place.

- To remove the battery pack, push the battery cover lever down and pull the battery pack out. Replace the battery cover afterwards.

5

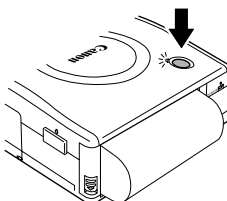

Turn the printer on.



- The printer consumes the battery charge when the power is on even when a function is not being used. To conserve the battery charge, be particularly attentive in turning the power off.
- Although the battery pack's maximum operating range is 5 to 40°C (41 to 104°F), the optimal range is 10 to 30°C (50 to 86°F). At cold temperatures, such as those experienced on ski hills, performance will temporarily decline, reducing the usable time.
- If the usable time of a battery pack diminishes substantially even when fully charged, it should be replaced.



- Avoid dropping or subjecting the battery pack to severe impact.
- Do not apply heat or expose the battery pack to open flame.
- Immediately flush water over parts of the body or clothing that come into contact with the inner contents of a battery if the outer casing incurs damage. If any of these substances should contact internal tissues, such as eyes or the mouth, immediately flush with water and seek medical assistance.
- Do not use the battery pack in products other than those recommended by Canon.
- When the battery pack is attached to the printer, unplug the compact power adapter.
- When the battery pack is attached to the printer, the printer will automatically turn off if it is idle for 5 minutes or more.
- Remove the battery pack when the printer is not in use.

Battery Status

If battery status is low while the printer is connected to the camera, the camera's LCD monitor may display the message indicated below.

Error Message	Correction
Recharge the printer battery	The battery pack's power is too low to operate the printer. Switch the battery pack for a fully charged one or recharge the battery pack.

Battery Performance

Number of prints	Postcard size paper: Approximately 18 sheets
------------------	---

Test conditions:

Room temperature (23°C, 73°F),
Canon images, Continuous print

- * The above data may vary according to the printing environment and the image to be printed.
- * At low temperatures, the battery pack performance may diminish and the low battery icon may appear very rapidly. In these circumstances, the performance can be improved by warming the battery pack in a pocket before use.



Using the Car Battery Adapter CBA-CP100 (Optional)

Car Battery Adapter CBA-CP100 (optional) can be used to power the printer from a car's cigarette lighter socket.

Please refer to the Car Battery Adapter User Guide for advice about proper handling.

Troubleshooting

If the printer does not seem to be working properly, run through the checks below to see if you can identify and correct the problem. If you are not able to solve the problem, please call your dealer or contact a Canon Customer Support help desk for assistance.

Problem	Cause	Correction
The printer has no power.	The compact power adapter or AC cable is not correctly connected.	Be sure that the compact power adapter and AC cable are connected correctly. Be sure that the AC cable is plugged in to a standard household power outlet.
The printer's indicator is flashing red.	There is a malfunction in the printer.	Press the ON/OFF button until the indicator's light turns off and press it again until the printer turns on.
The  (Direct Print mark) does not display in the upper left corner of the LCD monitor.	The cable is not correctly connected.	Connect the cable correctly (→ p. 22).
	The printer's power is off.	Turn the printer's power on (→ p. 22).
	Your camera's firmware is incompatible with this printer.	Please check the Canon BeBit website or your regional Canon website (→ p. 5).
The printer does not print.	The printer is not correctly connected to the camera.	Connect the cable correctly (→ p. 22). If the connection is correct, the  icon will appear on the camera's LCD monitor.
	The camera's batteries are depleted.	Replace with fresh (fully charged) batteries, or plug the camera into a power outlet (using the camera's optional compact power adapter).
	The printer's battery pack is depleted.	Use a new or fully charged battery pack or use the printer's compact power adapter.
	The ink cassette is not loaded correctly.	Load the ink cassette correctly.
	Too much slack in the ink cassette's ink sheet.	Take up the slack.
	The paper cassette is not pushed all the way in.	Load the paper cassette.
	The printer has overheated.	Wait for the printer to cool down.
Printing stopped midway.	The printer is not correctly connected to the camera.	Connect the direct interface cable correctly (→ p. 22).

Problem	Cause	Correction
The printer's indicator glows red without the camera's LCD monitor displaying any error message.	There is a malfunction in the printer.	Remove the paper from the paper handling slot and take up any slack in the ink sheet. Press the ON/OFF button until the indicator's light turns off and press it again until the printer turns on.
Print quality is not good.	You are not using the correct paper type.	Use the designated paper type.
	Paper is loaded wrong-side up.	Load the paper correctly (glossy side up).
	The ink sheet or paper is dirty.	Use a clean ink sheet and clean paper.
	Condensation has formed within the printer.	Wait for condensation to evaporate.
Faint stripes appear in the print.	Dust has accumulated inside the printer.	Remove the ink cassette and insert the cleaner in the direction of the arrow and with the arrow facing up. Push it in completely as shown in figure A and slide it in and out of the printer 2 or 3 times.
Printed images are distorted.	The printer is too close to a TV, video game machine, or other electromagnetic source.	Move the printer so that it is at least one meter (3.3 ft.) away from the electromagnetic source.
	The printer is too close to a stereo speaker, large motor, or other strong magnetic source.	Move the printer away from the strong magnetic source.
Nothing happens when the camera's SET button is pressed.	The printer has overheated.	Wait for the printer to cool down.
	Printing is in progress.	Wait for the printer to finish printing.
Frequent paper jams.	The paper cassette is overloaded.	Do not load more than 18 sheets of paper into the cassette.
	The print output receptacle is too full.	Do not allow more than 9 sheets to accumulate in the receptacle.
	Paper is creased or curled.	Do not use paper that is creased or curled.

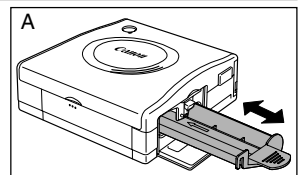

Error Messages

If a problem occurs while the printer is connected to the camera, the camera's LCD monitor may display one of the messages indicated below. (If the camera is connected to a TV, the message will appear on the TV screen.) Please note that these messages do not appear on the printer itself.

Error Message	Cause	Correction
No Paper	Paper cassette is incorrectly installed.	Load the paper cassette correctly.
	Paper is not loaded correctly in the paper cassette.	Load paper into the cassette correctly.
	No paper in the paper cassette.	Load paper into the cassette.
	Paper is not feeding correctly.	Take out the paper cassette, and then manually remove any paper remaining in the printer. Then, insert your finger in the hole under the printer and push out the paper.
No Ink	No ink cassette in the printer.	Load an ink cassette.
	The ink cassette is out of ink.	Load a new ink cassette.
Incompatible paper size	Wrong paper size is loaded in the printer.	Use the designated paper size.
Incompatible ink size	Wrong ink cassette size is loaded in the printer.	Use the designated ink cassette size.
Ink Cassette Error	The ink cassette is not working correctly.	Remove the ink cassette from the printer, take up the slack in the ink sheet, and then reload the cassette. If this does not solve the problem, replace with a new ink cassette. If the ink cassette is stuck in the printer, contact a Canon Customer Support help desk for assistance.
Paper and ink do not match	The paper and ink are from different sets.	Check the ink/paper sets.

Error Message	Cause	Correction
Paper Jam	Paper jammed during printing.	<p>Press the ON/OFF button until the indicator light turns off and press it again until the printer turns on.</p> <ul style="list-style-type: none"> • With postcard size and L size paper, the printer should respond by automatically ejecting the jammed sheet into the print receptacle or out through the paper handling slot. If the printer fails to eject the paper, contact a Canon Customer Support help desk for assistance. • With card size paper, remove the paper cassette, insert your finger in the paper-retrieving hole under the printer and push the paper out.
Paper has been changed.	Paper was changed after the print menu was displayed.	Change back to the original paper size or change the print settings.
Recharge the printer battery	The printer's battery pack is depleted.	Change it with a fully charged battery pack or recharge the battery pack.
Communication Error	Error in communication between printer and camera.	Press the ON/OFF button until the indicator light turns off and press it again until the printer turns on. If the error message does not clear, contact a Canon Customer Support help desk for assistance.
Cannot Print!	The image was taken with a different camera, recorded in a different format, or has been altered by a computer.	Check whether the image's size matches the camera's pixel capacity. If the size is not appropriate, resize the image and convert as necessary so that the image is in a JPEG format that the camera can display.

Error Message	Cause	Correction
Could not print xx images	You have selected a number of images for DPOF printing, but some of these images cannot be printed because they were taken with a different camera, recorded in a different format, or have been altered by a computer. (where xx indicates the number of unprintable images from among those selected.)	Check whether the image size matches the camera's pixel capacity. If sizes are not appropriate, resize the images and convert as necessary so that images are in a JPEG format that the camera can display.

Specifications

Card Photo Printer CP-100

General Specifications

Printer Type:	Full-color direct digital printer
Print Method:	Dye-sublimation thermal transfer (with overcoating)
Resolution Reproduction:	300 × 300 dpi
Gradation:	256 gradations/color
Ink:	Dedicated ink cassette for each paper size (Y/M/C/overcoating)
Paper:	Post card size (standard sheets) L size (standard sheets) Card size (standard sheets, full-sized label and 8-label sticker)
Paper-Feed Method:	Automatic feed from paper cassette
Paper-Eject Method:	Sheets eject onto top of paper cassette
Print Modes:	Standard (1-screen) print (bordered or borderless) Multiple (8-screen) print (for use with labels)
Print Sizes:	Postcard size print (borderless): 148 × 100 mm (5.8 × 3.9 in.) Postcard size print (bordered): 121.9 × 91.4 mm (4.8 × 3.6 in.) L size print (borderless): 119 × 89 mm (4.7 × 3.5 in.) L size print (bordered): 105.3 × 79.2 mm (4.2 × 3.1 in.) Card size print (full-sized, borderless): 86 × 54 mm (3.4 × 2.1 in.) Card size print (full-sized, bordered): 66.7 × 50 mm (2.6 × 2.0 in.) Card size Multiple print: 22 × 17.3 mm (0.9 × 0.7 in.) (per label)
Print Speeds*:	Postcard size print (bordered/borderless): 81 sec. L size print (bordered/borderless): 68 sec. Card size print (full-sized, bordered/borderless): 40 sec. Card size Multiple print: 40 sec.

Interface

Signal Transfer:	Proprietary protocol for Canon cameras
Connection Method:	Dedicated cable

Device Specifications

Operating Environment:	5 - 40°C (41 - 104°F), 20 % to 80 % RH (when running)
Power Source:	100 - 240 V (50/60 Hz)
Power Consumption:	50 W or less (4 W or less when idle)
Dimensions:	172(W) × 178(D) × 60(H) mm (6.8 × 7.0 × 2.4 in.)
Weight:	990 g (34.9 oz.) (excluding ink and paper cassettes)

* Test Conditions: Room temperature (23°C, 73°F), Canon standard images

Compact Power Adapter CA-CP100

Input voltage:	AC 100-240 V (50/60 Hz)
Rated output:	24 V, 2A
Operating temperatures:	0 - 40°C (32 - 104°F)
Dimensions:	100 × 50 × 24 mm (3.9 × 2.0 × 0.9 in.) (excluding cable)
Weight:	Approx. 200 g (7.1 oz.)

Battery Pack NB-CP1L

Supplied with the optional Battery/Charge Adapter Kit BCA-CP100, or sold separately.

Type:	Lithium ion battery
Nominal voltage:	22.2 V
Nominal capacity:	1200 mAh
Charge cycles:	Approx. 300
Operating temperatures:	5 - 40°C (41 - 104°F)
Dimensions:	110.0 × 40.7 × 37.5 mm (4.3 × 1.6 × 1.5 in.)
Weight:	Approx. 230 g (8.1 oz.)

Charge Adapter CG-CP100

Supplied with the optional Battery/Charge Adapter Kit BCA-CP100.

Input voltage:	DC 24 V
Rated output:	24 V, 0.7 A
Charging time:	2.5 hours
Operating temperatures:	0 - 40°C (32 - 104°F)
Dimensions:	136.7 × 46.5 × 41.1 mm (5.4 × 1.8 × 1.6 in.)
Weight:	Approx. 120 g (4.2 oz.)

Car Battery Adapter CBA-CP100 (Optional)

Input voltage:	DC 12 V, 90 W
Rated output:	24 V, 3.2 A
Operating temperatures:	0 - 40°C (32 - 104°F)
Dimensions:	89.4 × 63.3 × 40.0 mm (3.5 × 2.5 × 1.6 in.) (excluding cable)
Weight:	Approx. 370 g (13.1 oz.) (including cable)

The specifications and appearance are subject to change without notice.

FCC Notice

(Printer, Model CD1004)

This device complies with Part 15 of the FCC Rules. Operation is subject to the following two conditions;

- (1) this device may not cause harmful interference, and
- (2) this device must accept any interference received, including interference that may cause undesired operation.

Note: This equipment has been tested and found to comply with the limits for Class B digital devices, pursuant to Part 15 of the FCC rules. These limits are designed to provide reasonable protection against harmful interference in a residential installation. This equipment generates, uses and can radiate radio frequency energy and, if not installed and used in accordance with the instructions, may cause harmful interference to radio communications. However, there is no guarantee that interference will not occur in a particular installation. If this equipment does cause harmful interference to radio or television reception, which can be determined by turning the equipment off and on, the user is encouraged to try to correct the interference by one or more of the following measures:

- Reorient or relocate the receiving antenna.
- Increase the separation between the equipment and receiver.
- Connect the equipment into an outlet on a circuit different from that to which the receiver is connected.
- Consult the dealer or an experienced radio/TV technician for help.

Use of shielded cable with the ferrite core provided with the Printer is required to comply with Class B limits in Subpart B of Part 15 of the FCC rules.

Do not make any changes or modifications to the equipment unless otherwise specified in the manual. If such changes or modifications should be made, you could be required to stop operation of the equipment.

Canon U.S.A. Inc.

One Canon Plaza, Lake Success, NY 11042, U.S.A.

Tel No. (516) 328-5600

Canadian Radio Interference Regulations

THIS CLASS B DIGITAL APPARATUS MEETS ALL REQUIREMENTS OF THE CANADIAN INTERFERENCE CAUSING EQUIPMENT REGULATIONS.

Réglementation canadienne sur les interférences radio

CET APPAREIL NUMERIQUE DE LA CLASSE B RESPECTE TOUTES LES EXIGENCES DU REGLEMENT SUR LE MATERIEL BROUILLEUR DU CANADA.

Canon

日本語

- お買い求めいただいた商品の保証地域は、お手元の保証書に記載した地域に限定させていただきます。
- ここに書かれている内容は大事な情報ですので、大切に保管してください。
- 製品についてのお問い合わせ先は、製品本体の取扱説明書でご確認ください。

English

- The warranty of the product(s) is effective only in the country written on your warranty certificate.
- Please safekeep this sheet as it contains important information.

Deutsch

- Die Gültigkeit der Garantie des Productes/der Produkte beschränkt sich auf das angegebene Land auf Ihrem Garantieschein.
- Bitte bewahren Sie diesen Zettel sicher auf, da wichtige Information enthalten sind.

Español

- La garantía del producto o productos es válida sólo en el país que aparece escrito en su certificado de garantía.
- Guarde este impreso en lugar seguro ya que contiene información importante.

Français

- La garantie de ce ou ces produits n'est valide que dans le pays indiqué sur votre certificat de garantie.
- Veuillez conserver cette feuille car elle contient d'importantes informations.

Italiano

- La garanzia del prodotto (o prodotti) è valida solo nel paese indicato sul vostro certificato di garanzia.
- Siete pregati di tenere questo foglio in un posto sicuro perché contiene informazioni importanti.

中文简体

- 本产品的保证只在保证书上所记载的国家中有效。
- 此单记载有重要内容请妥善保管。

Canon Customer Support

Canon Inc.

30-2 Shimomaruko 3-chome, Ohta-ku, Tokyo
146-8501, Japan

NORTH AMERICA

Canon U.S.A., Inc.

Canon Customer Care Center
Phone (US): 1-800-828-4040 (Available Mon. - Fri., 9 AM to 8 PM Eastern Time)
www.powershot.com

Canon Canada Inc.

Phone (Canada): 1-800-OK-CANON (1-800-652-2666) (24 hours/day, 7 days/week)

EUROPE

Europe, Africa & Middle East

Canon Europa N.V.

PO Box 2262, 1180 EG Amstelveen, The Netherlands

Canon (UK) Ltd.

Helpdesk

Tel.: 08705 143 723 (Calls may be recorded.) Fax.: 08705 143 340

Canon Communication & Image France S.A.

Tél : 01.41.99.70.70 Fax : 01.41.99.79.50

Canon Deutschland GmbH

Customer Hotline: (02151) 349-555

Canon Italia S.p.A.

Pronto: Canon: 02 8249 2000 E-mail: support@canon.it

Canon Belgium N.V. / S.A.

Helpdesk: 0900-10627

Tel.: (02) 722.04.11 Fax: (02) 721.32.74

Canon Luxembourg S.A.

Tel.: (352) 48 47 961 Fax: (352) 48 47 96232

Canon Nederland N.V.

Helpdesk: 023 - 5 681 681

Tel.: 023 - 5 670 123 Fax: 023 - 5 670 124

Canon Danmark A/S

Phone: +45 44882400 e-mail: helpdesk@canon.dk

Canon España S.A.

Help Desk: 906 301 255

Fax: (91) 411 54 48 E-mail: helpdesk1@btlink.net

Canon Norge as

Tlf. 22 62 93 21

Download from www.Somanuals.com. All Manuals Search And Download.

Fax: 22 02 00 15 E-mail: helpdesk@canon.no

Finland

Canon OY

Puhelin: 010 54420 Fax: 010 544 4571
Help Desk: 0600 0 22606 (14,80 mk/min+pvm)
Help Desk: 0600 0 22666 (enint. 40mk/puhelu+pvm)
Sähköposti: helpdesk@canon.fi

Canon (Schweiz) AG

Tel. 01-835-6161 Fax: 01-835-6526 Hotline 0900 57 55 20

Canon Svenska AB

Helpdesk: 08-7448620

Austria

Canon GmbH

Zetschegasse 11, A-1230 Wien Vienna
Helpdesk Tel: 01 66 146 412 Fax: 01 66 146 308

OCEANIA

Canon Australia Pty. Ltd.

Info-Line: (02) 9805 2864
www.canon.com.au

Canon New Zealand Ltd.

Info-Line: 0900-522666
www.canon.co.nz

ASIA

Canon Singapore Pte. Ltd.

79 Anson Road, #09-01 / 06, Singapore 079906
Phone: (65) 532 4400 Fax: (65) 221 7577

Canon Hongkong Co., Ltd.

9/F, The Hong Kong Club Building, 3A Chater Road, Central, Hong Kong
Phone: 852-2739-0802 Fax: 852-2369-7701

Canon Marketing Services

No.1 Jalan Kilang Timor, #09-00, Pacific Tech Centre, Singapore 159303
Phone: (65) 799 8888 Fax: (65) 273 3317

Canon Marketing (Malaysia) Sdn. Bhd.

Wisma General Lumber, Block D, Peremba Square, Saujana Resort, Section U2, 40150,
Shah Alam, Selangor Darul Ehsan, Malaysia
Phone: (60) 3 744 6000, (60) 3 745 0055 Fax: (60) 3 745 0505

Canon Marketing (Thailand) Co., Ltd.

10th Floor, Bangkok City Tower, 179/34-45 South Sathorn Road, Bangkok 10120, Thailand
Phone: (662) 344 9999 Fax: (662) 344 9910

Canon Marketing (Hongkong) Co., Ltd.

10/F, Mirror Tower, 61 Mody Road, Tsimshatsui East, Kowloon HongKong
Phone: 852-2170-2828 Fax: 852-2723-9684

Download from www.Somanuals.com. All Manuals Search And Download.

修理サービスご相談窓口

キヤノン株式会社

キヤノン販売株式会社

〒108-8011 東京都港区三田3-12-15 東急三田ビル

修理サービスのご相談は、機種名をご確認のうえ、お買い上げの販売店または、下記の窓口にご相談ください。

サービスセンター

●北海道地区●

※札幌サービスセンター TEL 011-728-0665 〒060-8522 札幌市北区北7条西1-1-2 (SE山京ビル1F)

●東北地区●

※仙台サービスセンター TEL 022-217-3210 〒980-8560 仙台市青葉区国分町3-6-1 (仙台パークビル1F)

●関東・信越地区●

※新潟サービスセンター TEL 025-246-8765 〒950-0914 新潟市紫竹山1-10-26

※大宮サービスセンター TEL 048-649-1450 〒331-0852 さいたま市桜木町4-247 (OSビル1F)

●東京・神奈川・山梨地区●

東京QRセンター TEL 03-3837-2961 〒110-0005 東京都台東区上野1-1-12 (信井ビル1F)

銀座サービスセンター TEL 03-3573-7834 〒104-0061 東京都中央区銀座5-9-9

新宿サービスセンター TEL 03-3348-4725 〒163-0401 東京都新宿区西新宿2-1-1 (三井ビル1F)

※横浜サービスセンター TEL 045-312-0211 〒220-0004 横浜市西区北幸2-6-26 (HI横浜ビル2F)

●中部・北陸地区●

※静岡サービスセンター TEL 054-253-9010 〒420-0034 静岡市常盤町2-6-8 (トーカイビル3F)

※名古屋サービスセンター TEL 052-939-1830 〒461-8511 名古屋市東区東桜2-2-1 (高岳パークビル1F)

※金沢サービスセンター TEL 076-233-6608 〒920-0853 石川県金沢市本町1-5-2 (リファール1F)

●近畿地区●

※京都サービスセンター TEL 075-255-5953 〒604-0847 京都市中京区烏丸通2条下ル 秋野々町513番地 (京都第一生命泉屋ビル2F)

梅田カメラサービスセンター TEL 06-4795-9100 〒530-8260 大阪市北区梅田3-3-10 (梅田ダイビルB1)

※森ノ宮サービスセンター TEL 06-6942-7418 〒540-0003 大阪市中央区森ノ宮中央2-5-3

●中国・四国地区●

※岡山サービスセンター TEL 086-221-8678 〒700-0907 岡山市下石井2-2-5 (ニッセイ岡山スクエア13F)

※広島サービスセンター TEL 082-240-6712 〒730-0051 広島市中区大手町3-7-5 (広島パークビル1F)

※高松サービスセンター TEL 087-823-4681 〒760-0027 高松市紺屋町4-10 (鹿島紺屋町ビル1F)

●九州地区●

※福岡サービスセンター TEL 092-411-4173 〒812-0017 福岡市博多区美野島1-2-1 (キヤノン販売福岡ビル1F)

技術センター

※DC技術センター TEL 044-811-1670 〒213-0032 川崎市高津区久地487-1

※大阪カメラ技術センター TEL 06-6941-1076 〒540-0003 大阪市中央区森ノ宮中央2-5-3

※印のサービスセンターでは、郵送・宅配による修理品もお取扱いを致しております。

◎修理サービスご相談窓口の営業時間

東京QR: 10:00 ~ 18:00 (日・祝日は休ませていただきます)

銀座: 10:00 ~ 18:00 (土・日・祝日は休ませていただきます)

新宿: 10:00 ~ 18:00 (日・祝日は休ませていただきます)

梅田: 10:00 ~ 18:00 (日・祝日は休ませていただきます)

その他: 9:00 ~ 17:30 (土・日・祝日は休ませていただきます)

●2002年2月1日 Downloaded from www.software.com by All Manuals Search And Download. ご了承ください。



CANON® Card Photo Printer CP-100 Limited Warranty – For U.S.A. & Canada Only

Canon U.S.A.

You may obtain technical support for your Card Photo Printer CP-100 as follows:

- E-mail support via our Web site at www.usa.canon.com
- Telephone assistance from a Canon U.S.A. Customer Care representative free of charge during regular business hours (currently Monday-Friday 9:00 a.m.-8:00 p.m. EST, excluding holidays) at 1-800-828-4040 or 1-800-OK-CANON (1-800-652-2666).

Canon Canada

You may obtain technical support for your Card Photo Printer CP-100 as follows:

- Telephone assistance from a Canon Canada Customer Care representative free of charge during regular business hours (currently Monday-Friday 9:00 a.m.-8:00 p.m. EST, excluding holidays) at 1-800-OK-CANON (1-800-652-2666)

Have your Card Photo Printer CP-100 serial number and your date of purchase available when you make the call to expedite service. A Canon Customer Care representative will attempt to diagnose the nature of the problem and correct it over the telephone. If the problem cannot be corrected over the telephone, you will be asked to follow the applicable procedures for MAIL-IN SERVICE. Note that a dated proof of purchase is required at the time of service. This requirement will be satisfied by providing a copy of your dated bill of sale.

* Technical support program specifics subject to change without notice.

MAIL-IN SERVICE

MAIL-IN SERVICE is a program under which your Card Photo Printer CP-100 is repaired by a Canon U.S.A. or a Canon Canada authorized Card Photo Printer CP-100 service center. You will be given the name, address and phone number of an authorized Card Photo Printer CP-100 service center, by contacting the Canon U.S.A., Customer Care Center at 1-800-828-4040 or Canon Canada Customer Information Centre at 1-800-OK-CANON (1-800-652-2666). It is your responsibility to properly package and send the defective Card Photo Printer CP-100, together with a copy of your dated proof of purchase, a complete explanation of the problem and a return address to the authorized Card Photo Printer CP-100 service center at your expense. Do not include any other items with the defective Card Photo Printer CP-100. The defective Card Photo Printer CP-100 covered by this limited warranty will be repaired and returned to you without charge by the authorized Card Photo Printer CP-100 service center. Any Card Photo Printer CP-100 received by the authorized Card Photo Printer CP-100 service center that is not covered by the limited warranty will be returned unrepaired, or at the discretion of the authorized Card Photo Printer CP-100 service center, you may receive a written estimate of repair at such cost as the service center may establish from time to time.

This limited warranty gives you specific legal rights, and you may also have other rights, which vary from state to state (or province to province in Canada).

Canon U.S.A., Inc.
One Canon Plaza
Lake Success, NY 11042
USA

(The above address is not to be used for the MAIL-IN SERVICE program)

Canon Canada, Inc.
6390 Dixie Road
Mississauga, Ontario L5T 1P7
Canada

(The above address is not to be used for the MAIL-IN SERVICE program)



CANON[®] Card Photo Printer CP-100 Limited Warranty – For U.S.A. & Canada Only

The limited warranty set forth below is given by Canon U.S.A., Inc. (Canon U.S.A.) in the United States or Canon Canada Inc., (Canon Canada) in Canada with respect to the Canon-brand Card Photo Printer CP-100 purchased with this limited warranty, when purchased and used in the United States or Canada. The Card Photo Printer CP-100 purchased with this limited warranty is the only Card Photo Printer CP-100 to which this warranty card and the limited warranty provided by Canon U.S.A. or Canon Canada and stated on the card apply.

Your Card Photo Printer CP-100 or other contents, when delivered to you in new condition in its original container, is warranted against defects in materials or workmanship as follows: for a period of one (1) year from the date of original purchase, defective parts or a defective Card Photo Printer CP-100 returned to Canon U.S.A. or Canon Canada, or their authorized Card Photo Printer CP-100 service centers, as applicable, and proven to be defective upon inspection, will be repaired with new or comparable rebuilt parts or exchanged for a refurbished Card Photo Printer CP-100, as determined by Canon U.S.A. or Canon Canada, or the authorized Card Photo Printer CP-100 service center.

This limited warranty applies to the Card Photo Printer CP-100 itself and the following accessories: paper tray, AC cable, and interface cable. THIS WARRANTY DOES NOT COVER ANY ACCESSORIES NOT MENTIONED ABOVE. This limited warranty shall only apply if the Card Photo Printer CP-100 is used in conjunction with compatible computer equipment and compatible software, as to which items Canon U.S.A. or Canon Canada, shall have no responsibility. Non-Canon brand equipment and software that may be distributed with the Card Photo Printer CP-100 are sold "as is" and without warranty of any kind by Canon U.S.A. or Canon Canada, including any implied warranty regarding merchantability or fitness for a particular purpose, and all such warranties are disclaimed. The sole warranty, if any, with the respect to such non-Canon brand items is given by the manufacturer or producer thereof.

This limited warranty covers all defects encountered in normal use of the Card Photo Printer CP-100, and does not apply in the following cases:

- Loss of or damage to the Card Photo Printer CP-100 due to abuse, mishandling, improper packaging by you, alteration, accident, electrical current fluctuations, failure to follow operating, maintenance or environmental instructions prescribed in Canon U.S.A.'s or Canon Canada's user's manual or services performed by someone other than Canon U.S.A. or Canon Canada, or an authorized Card Photo Printer CP-100 service center. Without limiting the foregoing, water damage, sand/corrosion damage, battery leakage, dropping the printer, scratches, abrasions or damage to the connectors or cables, AC adapter or CompactFlash memory card, will be presumed to have resulted from misuse, abuse or failure to operate the Card Photo Printer CP-100 as set forth in the operating instructions.
- Use of parts or supplies (other than those sold by Canon U.S.A. or Canon Canada) that cause damage to the Card Photo Printer CP-100 or cause abnormally frequent service calls or service problems.
- If the Card Photo Printer CP-100 has had its serial number or dating altered or removed.

NO IMPLIED WARRANTY, INCLUDING ANY IMPLIED WARRANTY OF MERCHANTABILITY OR FITNESS FOR A PARTICULAR PURPOSE, APPLIES TO THE CARD PHOTO PRINTER CP-100 AFTER THE APPLICABLE PERIOD OF THE EXPRESS LIMITED WARRANTY STATED ABOVE, AND NO OTHER EXPRESS WARRANTY OR GUARANTEE, EXCEPT AS MENTIONED ABOVE, GIVEN BY ANY PERSON OR ENTITY WITH RESPECT TO THE CARD PHOTO PRINTER CP-100 SHALL BIND CANON U.S.A. OR CANON CANADA. (SOME STATES AND PROVINCES DO NOT ALLOW LIMITATIONS ON HOW LONG AN IMPLIED WARRANTY LASTS, SO THE ABOVE LIMITATION MAY NOT APPLY TO YOU.) CANON U.S.A. OR CANON CANADA SHALL NOT BE LIABLE FOR LOSS OF REVENUES OR PROFITS, INCONVENIENCE, EXPENSE FOR SUBSTITUTE EQUIPMENT OR SERVICE, STORAGE CHARGES, LOSS OR CORRUPTION OF DATA, OR ANY OTHER SPECIAL, INCIDENTAL OR CONSEQUENTIAL DAMAGES CAUSED BY THE USE OR MISUSE OF, OR INABILITY TO USE, THE CARD PHOTO PRINTER CP-100, REGARDLESS OF THE LEGAL THEORY ON WHICH THE CLAIM IS BASED, AND EVEN IF CANON U.S.A. OR CANON CANADA HAS BEEN ADVISED OF THE POSSIBILITY OF SUCH DAMAGES. IN NO EVENT SHALL RECOVERY OF ANY KIND AGAINST CANON U.S.A. OR CANON CANADA BE GREATER IN AMOUNT THAN THE PURCHASE PRICE OF THE CARD PHOTO PRINTER CP-100 SOLD BY CANON U.S.A. OR CANON CANADA AND CAUSING THE ALLEGED DAMAGE. WITHOUT LIMITING THE FOREGOING, YOU ASSUME ALL RISK AND LIABILITY FOR LOSS, DAMAGE OR INJURY TO YOU AND YOUR PROPERTY AND TO OTHERS AND THEIR PROPERTY ARISING OUT OF USE OR MISUSE OF, OR INABILITY TO USE, THE CARD PHOTO PRINTER CP-100 NOT CAUSED DIRECTLY BY THE NEGLIGENCE OF CANON U.S.A. OR CANON CANADA. (SOME STATES AND PROVINCES DO NOT ALLOW THE EXCLUSION OR LIMITATION OF INCIDENTAL OR CONSEQUENTIAL DAMAGES, SO THE ABOVE EXCLUSION OR LIMITATION MAY NOT APPLY TO YOU.) THIS LIMITED WARRANTY SHALL NOT EXTEND TO ANYONE OTHER THAN THE ORIGINAL PURCHASER OF THE CARD PHOTO PRINTER CP-100, OR THE PERSON FOR WHOM IT WAS PURCHASED AS A GIFT, AND SUCH PURCHASES ARE LIMITED TO THE ORIGINAL PURCHASER.

CANON U.S.A., INC.**CANON CANADA INC.**NAME
NOMADDRESS
ADRESSECITY
VILLE

PROVINCE

POSTAL CODE
CODE POSTALTHIS WARRANTY CARD AND YOUR BILL OF SALE MUST BE
PRESENTED FOR WARRANTY SERVICE.CETTE CARTE DE GARANTIE ET VOTRE PREUVE D'ACHAT
DOIVENT ÊTRE PRÉSENTÉS POUR RECEVOIR LE SERVICE SOUS
GARANTIE.DEALER'S NAME & ADDRESS
MARCHAND NOM & ADRESSE

MODEL

MODELE **Digital Printer CP-100**

BODY NO.

BOITIER NO **4401020611**

PURCHASE DATE

DATE D'ACHAT

Canon

Dealer Record of Canon Purchase
Fiche d'Achat pour Concessionnaire Canon

Complete this card at time of sale.
A remplir au moment de l'achat

PRESENT OWNERSHIP AND PRODUCTS INTERESTED IN

Articles déjà en possession ou jugés dignes d'intérêt

OWNS INTERESTED IN
En Possession Intéressé par

CAMERAS _____ (Camera) _____ (Lens)
APPAREILS _____ (Appareil) _____ (Objectif)
PHOTO _____ (Camera) _____ (Lens)
_____ (Appareil) _____ (Objectif)

•
•

•
•

INTERCHANGEABLE LENS

Objectif interchangeable

OWNS

En possession

INTERESTED IN

Intéressé par

OTHER ACCESSORIES

Autres accessoires

OWNS

En possession

INTERESTED IN

Intéressé par

MODEL Modèle	Digital Printer CP-100	SERIAL NO. No. de série	4401020611

CUSTOMER

Client

NAME

Nom

ADDRESS

Adresse

CITY/STATE

Ville/Province

ZIP

PHONE

Download from www.Somanuals.com All Manuals Search And Download

Canon

Garantie limitée des imprimantes photo format carte de crédit CP-100 card photo printer de CANON® — Pour les États-Unis et le Canada seulement

La présente garantie limitée est fournie par Canon U.S.A., Inc. (« Canon U.S.A. ») aux États-Unis ou Canon Canada Inc. (« Canon Canada ») au Canada à l'égard de l'imprimante photo format carte de crédit CP-100 de marque Canon, du réceptacle papier, du câble c.a. et du câble vidéo pour l'imprimante photo format carte de crédit CP-100 (collectivement « l'imprimante photo format carte de crédit CP-100 »), livrés avec cette garantie limitée, lorsqu'ils sont achetés et utilisés aux États-Unis ou au Canada.

Toute imprimante photo format carte de crédit CP-100, livrée à l'état neuf dans son emballage d'origine, est garantie contre tout vice de matière et de fabrication comme suit : pendant une période de un (1) an à compter de la date de l'achat initial, les pièces ou l'imprimante photo format carte de crédit CP-100 défectueuses qui seront retournées à Canon U.S.A. ou Canon Canada, ou à leurs fournisseurs de service agréés d'imprimantes photo format carte de crédit CP-100, selon le cas, et dont l'inspection confirme une défectuosité seront réparées avec de nouvelles pièces ou des pièces remises à neuf comparables, ou échangées contre une imprimante photo format carte de crédit CP-100 remise à neuf, tel que déterminé par Canon U.S.A. ou Canon Canada, ou le fournisseur de service agréé d'imprimantes photo format carte de crédit CP-100, à leur seule discrétion.

CETTE GARANTIE NE COUVRE PAS LES ACCESSOIRES QUI NE SONT PAS MENTIONNÉS AU PREMIER PARAGRAPHE CI-DESSUS. La présente garantie limitée s'applique seulement si l'imprimante photo format carte de crédit CP-100 est utilisée conjointement avec un équipement informatique compatible et des logiciels compatibles, pour lesquels Canon U.S.A. ou Canon Canada n'assume aucune responsabilité.

L'équipement et les logiciels de marque autres que Canon qui peuvent être distribués avec l'imprimante photo format carte de crédit CP-100 sont vendus « tels quels », sans garantie d'aucune sorte par Canon U.S.A. ou Canon Canada, y compris toute garantie implicite à l'égard de la qualité marchande ou de l'aptitude à une fin particulière. La seule garantie, si garantie il y a, liée à un article d'une marque autre que Canon, est donnée par le fabricant ou le producteur de cet article.

La présente garantie limitée couvre toutes les défectuosités constatées pendant l'utilisation normale de l'imprimante photo format carte de crédit CP-100, et ne s'applique pas aux cas suivants :

- La perte ou l'endommagement de l'imprimante photo format carte de crédit CP-100 causé par l'usage abusif, la manipulation négligente, l'emballage inadéquat fait par vous, les modifications, les accidents, les variations de courant électrique, l'omission d'observer les directives à l'égard du mode d'utilisation, des conditions d'entretien et du milieu ambiant énoncées dans le manuel d'utilisation de Canon U.S.A. ou Canon Canada, ou de l'entretien effectué ailleurs que chez Canon U.S.A. ou Canon Canada, ou un fournisseur de service agréé d'imprimantes photo format carte de crédit CP-100 ;
- L'utilisation de pièces ou de fournitures (autres que celles vendues par Canon U.S.A. ou Canon Canada) ayant pour effet d'endommager l'imprimante photo format carte de crédit CP-100 ou d'entraîner une fréquence anormale d'appels d'entretien ou de problèmes nécessitant le recours au service d'entretien et après-vente ;
- La modification ou le retrait du numéro de série ou de datation de l'imprimante photo format carte de crédit CP-100.

AUCUNE GARANTIE IMPLICITE, Y COMPRIS TOUTE GARANTIE IMPLICITE À L'ÉGARD DE LA QUALITÉ MARCHANDE OU DE L'APTITUDE À UNE FIN PARTICULIÈRE, NE S'APPLIQUE À L'IMPRIMANTE PHOTO FORMAT CARTE DE CRÉDIT CP-100 APRÈS LA PÉRIODE PRÉSCRITE DE LA GARANTIE EXPRESSE LIMITÉE SUSMENTIONNÉE ET, À L'EXCEPTION DE LADITE GARANTIE EXPRESSE LIMITÉE, AUCUNE AUTRE GARANTIE EXPRESSE NI AUCUNE AUTRE GARANTIE ACCORDÉE PAR TOUTE PERSONNE OU ENTITÉ À L'ÉGARD DE L'IMPRIMANTE PHOTO FORMAT CARTE DE CRÉDIT CP-100 N'AURA POUR EFFET DE LIER CANON U.S.A. OU CANON CANADA À TOUTE OBLIGATION, QUELLE QU'ELLE SOIT (CERTAINS ÉTATS ET CERTAINES PROVINCES N'AUTORISENT AUCUNE RESTRICTION SUR LA DURÉE D'UNE GARANTIE IMPLICITE ; AINSI, IL EST POSSIBLE QUE LA RESTRICTION ÉNONCÉE CI-DESSUS NE S'APPLIQUE PAS DANS VOTRE CAS.) CANON U.S.A. OU CANON CANADA N'ASSUME AUCUNE RESPONSABILITÉ À L'ÉGARD DE LA PERTE DE PRODUITS D'EXPLOITATION OU DE PROFITS, NI À L'ÉGARD DES INCONVÉNIENTS ET DES FRAIS ENGAGÉS POUR DE L'ÉQUIPEMENT DE REMPLACEMENT, DES SERVICES D'ENTRETIEN ET APRÈS-VENTE, POUR L'ENTREPOSAGE, LA PERTE OU LA CORRUPTION DE DONNÉES, NI À L'ÉGARD DE TOUT DOMMAGE SPÉCIAL, INDIRECT OU ACCESSOIRE DÉCOULANT DE L'USAGE OU DE L'USAGE IMPROPRE, OU DE L'IMPOSSIBILITÉ D'UTILISER L'IMPRIMANTE PHOTO FORMAT CARTE DE CRÉDIT CP-100, QUELLE QUE SOIT L'ARGUMENTATION JURIDIQUE SUR LAQUELLE S'APPUIE LA DEMANDE, ET MÊME SI CANON U.S.A. OU CANON CANADA A ÉTÉ INFORMÉE DE LA POSSIBILITÉ DE TELS DOMMAGES, AUCUN RECOURS, QUELLE QU'EN SOIT LA FORME, CONTRE CANON U.S.A. OU CANON CANADA NE SERA SUPÉRIEUR AU MONTANT DU PRIX D'ACHAT DE L'IMPRIMANTE PHOTO FORMAT CARTE DE CRÉDIT CP-100 VENDUE PAR CANON U.S.A. OU CANON CANADA ET À L'ORIGINE DES DOMMAGES PRÉSUMÉS, SANS VOUS LIMITER À LA PORTÉE GÉNÉRALE DE CE QUI PRÉCÈDE, VOUS ASSUMEZ TOUS LES RISQUES ET TOUTE LA RESPONSABILITÉ À L'ÉGARD DES PERTES, DES DOMMAGES MATÉRIELS ET DES BLESSURES CORPORELLES SUBIS PAR VOUS, VOTRE PROPRIÉTÉ OU D'AUTRES PERSONNES OU LEUR PROPRIÉTÉ EN RAISON DE L'USAGE, DE L'USAGE IMPROPRE, OU DE L'IMPOSSIBILITÉ D'UTILISER L'IMPRIMANTE PHOTO FORMAT CARTE DE CRÉDIT CP-100 À MOINS QUE LESDITS DOMMAGES MATÉRIELS, PERTES ET BLESSURES CORPORELLES N'AIENT ÉTÉ CAUSÉS PAR LA NÉGLIGENCE DE CANON U.S.A. OU CANON CANADA (CERTAINS ÉTATS ET CERTAINES PROVINCES N'AUTORISENT AUCUNE EXCLUSION NI RESTRICTION DES DOMMAGES ACCESSOIRES OU INDIRECTS ; AINSI, IL EST POSSIBLE QUE LA RESTRICTION OU L'EXCLUSION ÉNONCÉE CI-DESSUS NE S'APPLIQUE PAS DANS VOTRE CAS.) LA PRÉSENTE GARANTIE LIMITÉE NE SERT PAS À ACCORDER À D'AUTRES PERSONNES QUE L'ACHÈTEUR INITIAL DE TOUTE IMPRIMANTE PHOTO FORMAT CARTE DE CRÉDIT CP-100 OU LA PERSONNE QUI A REÇU LADITE IMPRIMANTE PHOTO FORMAT CARTE DE CRÉDIT CP-100 EN CADEAU, ET CONSTITUE VOTRE RECOURS EXCLUSIF



Garantie limitée des imprimantes photo format carte de crédit CP-100 card photo printer de CANON – Pour les États-Unis et le Canada seulement

Canon U.S.A.

Des services de soutien technique pour votre imprimante photo format carte de crédit CP-100 sont offerts comme suit :

- Soutien par courrier électronique au moyen du site Web de Canon U.S.A. : www.usa.canon.com
- Soutien téléphonique auprès d'une représentante ou d'un représentant du Centre de renseignements clientèle de Canon U.S.A., sans frais, pendant les heures normales d'ouverture (actuellement du lundi au vendredi de 9 h à 20 h, HNE, à l'exception des jours fériés) au 1 800 828-4040 ou 1 800 OK CANON (1 800 652-2666)

Canon Canada

Des services de soutien technique pour votre imprimante photo format carte de crédit CP-100 sont offerts comme suit :

- Soutien téléphonique auprès d'une représentante ou d'un représentant du Centre de renseignements clientèle de Canon Canada, sans frais, pendant les heures normales d'ouverture (actuellement du lundi au vendredi de 9 h à 20 h, HNE, à l'exception des jours fériés) au 1 800 OK CANON (1 800 652-2666).

Lors de l'appel, assurez-vous d'avoir le numéro de série de l'imprimante photo format carte de crédit CP-100 et la date de son achat à portée de la main afin d'accélérer le service. Une représentante ou un représentant du Centre de renseignements clientèle de Canon U.S.A. ou de Canon Canada tentera, le cas échéant, de déterminer la source du problème et de résoudre celui-ci par téléphone. S'il est impossible de résoudre le problème par téléphone, on vous priera de suivre les directives appropriées pour le SERVICE POSTAL.

Les conditions du programme de soutien technique sont modifiables sans préavis.

SERVICE POSTAL

Le SERVICE POSTAL est un programme selon lequel les réparations de votre imprimante photo format carte de crédit CP-100 sont effectuées par un fournisseur de service agréé d'imprimantes photo format carte de crédit CP-100 de Canon U.S.A. ou Canon Canada. Vous obtiendrez le nom, l'adresse et le numéro de téléphone d'un fournisseur de service agréé d'imprimantes photo format carte de crédit CP-100, en communiquant avec le Centre de renseignements clientèle de Canon U.S.A., au 1 800 828-4040 ou avec le Centre d'information à la clientèle de Canon Canada au 1 800 OK CANON (1 800 652-2666). Il vous incombe d'emballer adéquatement votre imprimante photo format carte de crédit CP-100 défectueuse et de la faire parvenir, à vos frais, accompagnée d'une copie de votre preuve d'achat datée (un acte de vente dûment daté suffit), d'une explication détaillée du problème et de l'adresse de retour au fournisseur de service agréé d'imprimantes photo format carte de crédit CP-100. Vous ne devez inclure aucun autre article avec l'imprimante photo format carte de crédit CP-100 défectueuse. L'imprimante photo format carte de crédit CP-100 couverte par la présente garantie limitée sera réparée et vous sera retournée sans frais par le fournisseur de service agréé d'imprimantes photo format carte de crédit CP-100. Les imprimantes photo format carte de crédit CP-100 non couvertes par la présente garantie limitée reçues par le fournisseur de service agréé d'imprimantes photo format carte de crédit CP-100 seront retournées sans avoir été réparées ou, à la discrétion du fournisseur de service agréé d'imprimantes photo format carte de crédit CP-100, vous pourrez recevoir une estimation écrite des frais de réparation au coût tel qu'il est établi à l'occasion par le fournisseur de service.

La présente garantie limitée vous accorde des droits particuliers reconnus par la loi et il se peut que vous disposiez d'autres droits qui peuvent varier d'un État à un autre (ou d'une province à une autre au Canada).

Canon U.S.A., Inc.
One Canon Plaza
Lake Success, NY 11042
USA

(L'adresse ci-dessus ne doit pas être utilisée dans le cadre du programme de SERVICE POSTAL.)

Canon Canada Inc.
8390 ch Dixie
Mississauga ON L5T 1P7
Canada

(L'adresse ci-dessus ne doit pas être utilisée dans le cadre du programme de SERVICE POSTAL.)

Download from www.Somanuals.com All Manuals Search And Download.

Tous les autres noms de marques ou de produits sont des marques déposées ou des marques de commerce de leurs propriétaires respectifs.

保護シート

これは保護シートです。ペーパーカセットにペーパーを設置する前に取り除いてください。

Protection Sheet

Remove this sheet before putting paper in the paper cassette.

Feuille de protection

Veillez à retirer cette feuille de protection avant toute impression

Bitte entfernen Sie dieses Blatt, bevor Sie das Papier in die Papierkassette legen.

Retire esta protección antes de colocar el papel en el cassette

Foglio di protezione

Rimuovere questo foglio prima di inserire la carta nel cassetto.

保护片

将纸张放入纸匣之前，请移除此片。

Canon



23MBC0060

Copyright © 2003 Canon U.S.A., Inc. All rights reserved. Canon, the Canon logo, and PowerLite are registered trademarks of Canon U.S.A., Inc. in the United States and other countries. PowerLite is a registered trademark of PowerLite, Inc. in the United States and other countries. All other trademarks are the property of their respective owners.



Free Manuals Download Website

<http://myh66.com>

<http://usermanuals.us>

<http://www.somanuals.com>

<http://www.4manuals.cc>

<http://www.manual-lib.com>

<http://www.404manual.com>

<http://www.luxmanual.com>

<http://aubethermostatmanual.com>

Golf course search by state

<http://golfingnear.com>

Email search by domain

<http://emailbydomain.com>

Auto manuals search

<http://auto.somanuals.com>

TV manuals search

<http://tv.somanuals.com>