

# CanoScan FS2720U Film Scanner

# Product Guide

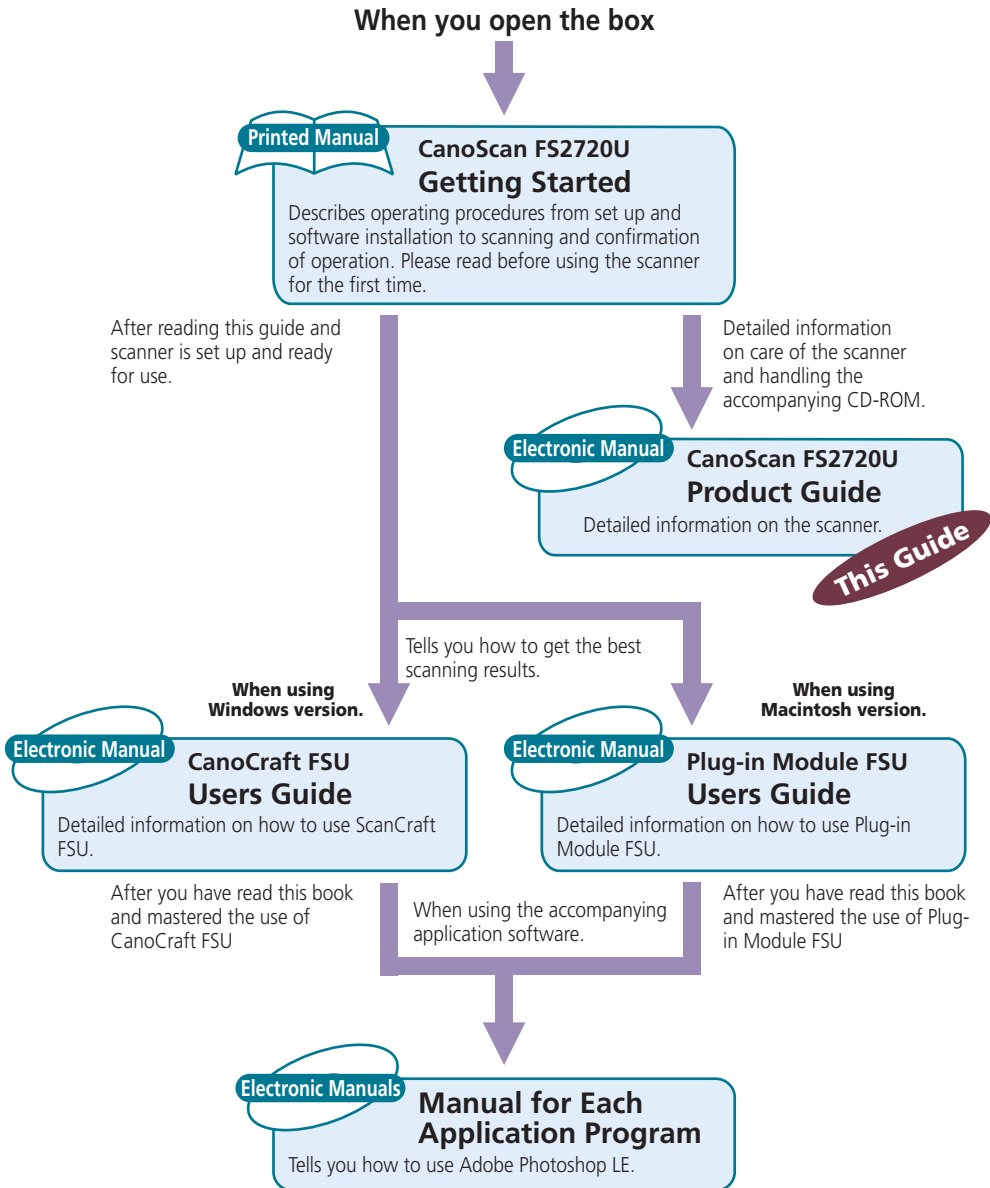

# How to Make Best Use of the Manuals





# How to Use the Product Guide

This guide is the supplementary manual to the *Getting Started Guide* for the CanoScan FS2720U film scanner. First-time users of the CanoScan FS2720U should start by consulting the *Getting Started Guide*, which explains handling procedures. This Product Guide provides more detail for the topics that could not be included in the *Getting Started Guide*.

## Using the Features of this Electronic Manual

---

This guide is an electronic manual intended to be read on your computer screen. You can jump directly to items of interest by clicking them in the table of contents and index, or by clicking hyper links throughout the document.

- The mouse pointer () changes into a pointing finger () when you position it over a topic in the table of contents, an index page number, or a page number in a hyper link. This indicates that the display will jump to the corresponding page if you click the mouse.
- To return to the previous page after jumping, click the [] button at the top of the window.

## Conventions Used in this Guide

---

**WARNING**

This symbol indicates precautions that must be taken when operating the equipment. Ensure that you read all warnings.

**NOTE**

This symbol indicates supplementary operating procedures and other useful information. Read these notes at your own discretion.

- References to Windows in this guide refer to Windows® 98 SE, Windows® 2000 Professional and Windows® Me.

# Table of Contents

Features of the CanoScan FS2720U Film Scanner .....	5
<b>⚠ Safety Precautions</b> .....	<b>6</b>
Placement Precautions .....	6
Power Supply Precautions .....	7
General Handling Precautions .....	8
<b>Safe Locations</b> .....	<b>9</b>
<b>Components Guide</b> .....	<b>11</b>
Scanner .....	11
35 mm Film Holder .....	11
IW-50 Film Viewer for IX240 Film .....	12
<b>Connecting to a Computer</b> .....	<b>13</b>
What is the USB Interface? .....	13
USB Connectors .....	13
Connecting Multiple USB Devices .....	13
<b>Inserting Film</b> .....	<b>14</b>
35 mm Negative and Positive Film (Sleeve Type) .....	14
35 mm Positive Film (Mounted Slides) .....	17
IX240 Film .....	18
IX240 Film Cartridge Removal .....	22
<b>Basic Information About Film</b> .....	<b>23</b>
Film Varieties .....	23
Color/Monochrome Film .....	23
Negative/Positive Film .....	24
Final Film Format .....	25
<b>Care and Maintenance</b> .....	<b>26</b>
<b>Cleaning Film</b> .....	<b>27</b>
Dirty Film .....	27
Dusty Film .....	27
<b>Specifications</b> .....	<b>28</b>
<b>Index</b> .....	<b>29</b>



# Features of the CanoScan FS2720U Film Scanner

This 2720-dots-per-inch scanner is equipped with a range of outstanding features, a few of which are mentioned below.

## **Natural Color Reproduction**

The CanoScan FS2720U utilizes a white cold-cathode xenon lamp, highly rated for reproducing colors closely correlated to natural sunlight. Its proprietary Canon electrode array also eliminates inconsistencies in illumination. What's more, its extensive list of notable features includes long life, low power consumption and immediate startup when the power is switched on.

## **Fine Color Gradations and High Quality**

The scanner is equipped with dedicated line sensors that deliver a basic resolution of 2720 dpi for each red, blue and green (RBG) channel. This is complemented by its single-pass scanning process, which achieves speed without color leaching. By scanning at 12 bits per RBG channel (4096 colors each) and outputting at 8 or 12 bits per channel, the scanner delivers fine color gradations and superior image quality.

## **IX240 Film (Advanced Photo System) Support**

The IW-50 Film Viewer is included so that IX240 film used in Advanced Photo System cameras can be as easily processed as standard 35 mm Film.

## **Fully Automated (Autofocus/Auto Color Balance)**

After the film is inserted, all you need do is click the [Scan] or [Save] button on your computer screen. The focus, brightness and color balance adjust automatically to produce top-quality images effortlessly.

## **Dust Cover Shuts Out Dirt**

The scanner is equipped with a dust cover that stops dirt and dust from entering the interior.



## Safety Precautions

The following tips were compiled to provide you with the requisite information for using this product safely. Please read this section completely before using the equipment.

About the Caution and Attention Symbols

 **CAUTION** This symbol indicates handling precautions that must be observed to avoid the potential risk of death or injury. Ensure that you read and follow the instructions contained in these topics.

 **ATTENTION** This symbol indicates handling precautions that must be observed to avoid potential accidents and damage to equipment. Ensure that you read and follow the instructions contained in these topics.

## Placement Precautions

 **CAUTION**

- Do not place the equipment near alcohol, thinners or other flammable substances. There is a risk of fire or electric shock if flammable substances enter the equipment's interior.
- Do not place any of the following items on top of the equipment. There is a risk of fire or electric shock if any of these items contact the equipment's internal electrical components.
  - Necklaces and other metallic objects
  - Liquid filled vessels, such as cups, glasses, flower pots and vases
- If a liquid enters the equipment, immediately unplug the power cord from the electrical outlet and contact your distributor or the nearest Canon Customer Support Help Desk, which is listed at the back of the Getting Started Guide.

 **ATTENTION**

- Do not place the equipment in the following types of location, which may involve the risk of fire or electric shock.
  - Damp or dusty environments
  - Locations subject to direct sunlight
  - Locations subject to high temperatures
  - Locations close to flames
- Do not place the equipment on uneven or unstable surfaces or places subject to vibration. There is a risk that the equipment could fall and cause injury.
- Do not place heavy objects on the equipment. There is a risk that they could fall and cause injury.

## Power Supply Precautions

---

### CAUTION

- Do not score, damage or dismantle the power cord or plug. In addition, do not place heavy objects on, twist or force the cord. There is a risk that short-circuits from exposed wiring could lead to fire or electric shock.
- Do not handle the plug with wet hands. There is a risk of electric shock.
- Avoid plugging too many power cords into the same electrical outlet. There is a risk of fire or electric shock.
- Do not bunch up or knot the power cord. There is a risk of fire or electric shock.
- Insert the plug of the power cord all of the way into the electrical outlet. Loose plugs may lead to fire or electric shock.
- Do not use a power cord other than the type shipped with the equipment. Use of other cords may lead to fire or electric shock.
- In principle, avoid using extension cords, which may lead to fire or electric shock. If their use is unavoidable, limit the length to 5 meters (16 feet) or less. In addition, unbunch the cords and ensure that power and extension plugs are firmly connected. Do not use more than one extension cord in the same electrical outlet.
- Do not use extension cords in passageways or other locations where people are likely to step on or trip over the cord and damage it. Short-circuits from exposed wiring could lead to fire and electric shock.

### ATTENTION

- Do not use the equipment with electrical supplies exceeding the rated voltage. There is a risk of fire or electric shock.
- Ensure that you grasp the plug by its solid portion when unplugging the power cord. Pulling it out by the cord may wear the cord, expose the insulation and wiring, and lead to fire or electric shock.
- Always leave a clear area around the electrical outlet so that the power cord can be immediately unplugged if a contingency should arise.
- Unplug the power cord from the electrical outlet at least once a year, and clean the area around the base of the plug's metal pins to ensure all dust is removed. If dust accumulates in this area, it may result in a fire.

## General Handling Precautions

---

### CAUTION

- Do not disassemble, alter or attempt to repair any part of the equipment. The internal components include high-voltage parts that may lead to fire or electric shock if incorrectly handled or repaired.
- Unplug the equipment immediately if it emits strange noises, smoke or heat, or responds abnormally. Contact the distributor or the nearest Canon Customer Support Help Desk. Continued use of the equipment could lead to fire or electric shock.
- Do not use flammable sprays or substances near the equipment. There is a risk of fire or electric shock if the spray contacts the equipment's internal components.
- Do not insert or drop metallic objects, such as paperclips or staples, into the interior of the equipment. Be careful also not to spill water, other liquids or solvents (alcohol, benzene or thinners, etc.) into it. There is a risk of fire or electric shock if any of these substances contact the equipment's internal components. Immediately unplug the equipment if anything gets inside it and contact your distributor or the nearest Canon Customer Support Help Desk.
- Do not use the equipment on its side.
- Unplug the equipment before cleaning it. Failure to do so could lead to fire or electric shock.
- Use a well-wrung damp cloth to clean the exterior of the equipment. Do not use alcohol, benzene, thinners or other flammable substances to clean it. Contact between these substances and the equipment's electrical components could lead to fire or electric shock.

### ATTENTION

- Unplug the equipment as a safety precaution if it will be left unused over an extended period, such as a holiday.
- Take adequate care when carrying or moving the equipment. Dropping it may cause injury.
- Wait for the equipment to cool down after removing the plug before covering it with a dust cover or similar device. There is a risk of fire.
- Do not play the CD-ROM in an audio CD player. The loud volume of its contents may lead to ear damage.



## Safe Locations

Follow the guidelines below to locate a safe place to operate the scanner.

- Operate the scanner within the following parameters.
  - Temperature range: 5° to 35° C (41° - 95° F)
  - Humidity range: 10% to 90% relative humidity (without condensation)
- Operate the scanner with a power supply conforming to the following parameters.
  - Voltage: 110V (10% volts alternating current)
  - Frequency: 50/60 Hertz
- Ensure that there is sufficient clear space around the scanner. The diagram illustrates the space that should be kept clear as viewed from directly above the unit.

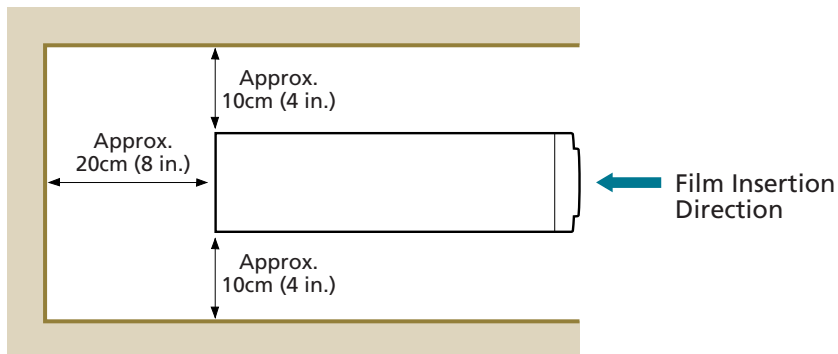

- The interface cable supplied with the scanner is 1.85 meters (6 feet) in length. Ensure that the scanner is placed within its reach.
- Do not place it in locations subject to extreme changes in temperature or humidity, which may cause condensation to form and reduce the scanner's image quality. If the scanner is being transported from a high temperature to a low temperature, or vice versa, allow the unit sufficient time to adjust to the new temperature before using it.
- Do not use the scanner in places subject to direct sunlight or strong light. There is a risk that the elevated temperature of the internal components may cause a malfunction or degraded performance. Shield it with thick curtains if a location subject to direct sunlight is unavoidable.

- Do not place the scanner in the following types of location.

Uneven or unstable surfaces

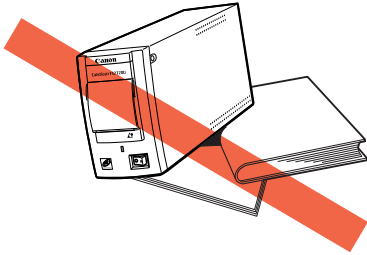

High-temperature environments or places close to flames

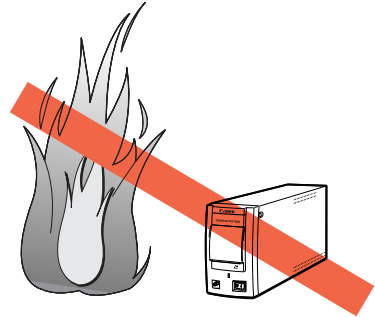

Locations often subject to vibrations, smoke, humidity or dust

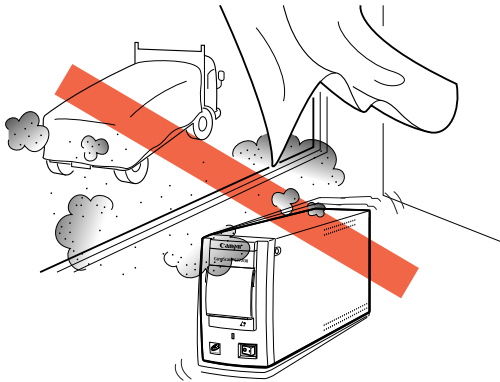

Locations near TVs or devices generating strong magnetic fields

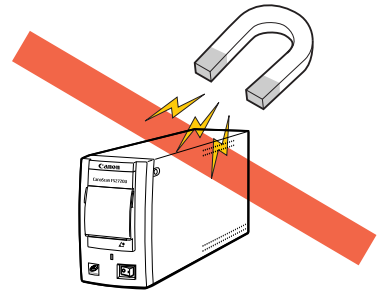

Salty or greasy environments

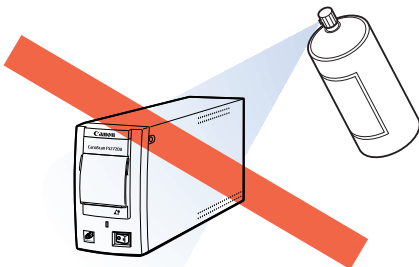

Locations subject to direct sunlight or strong light

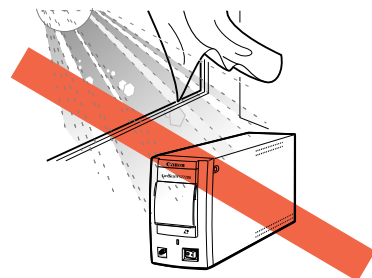

# Components Guide

## Scanner

### Film Guide

Guides 35 mm film in holders or slide mounts as it is inserted. Open this guide to insert IX240 film installed in the IW-50 Film Viewer.

### Dust Cover

Prevents dirt and dust from entering the slot. Close it when the film guide is not in use.

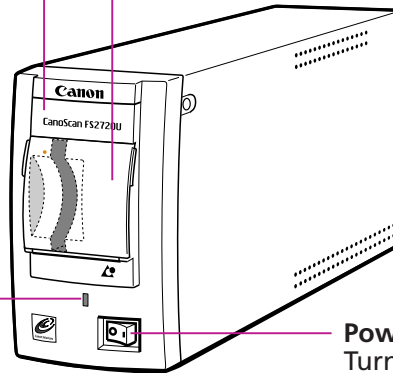

### Power Indicator

Flashes until the unit is ready for use. Shines steadily thereafter while the power is on.

### Power Switch

Turns the scanner power on and off.

### Power Cord Socket

Attach the supplied power cord here.

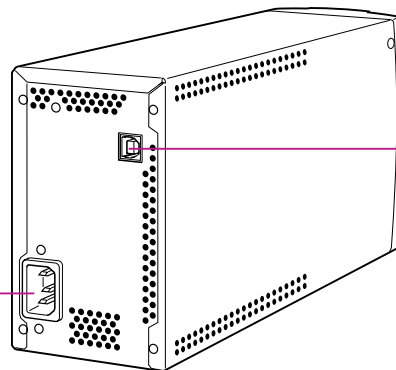

### USB Port

Accepts the supplied USB interface cable.

## 35 mm Film Holder

Place unmounted 35 mm negative and positive films in this holder for scanning. (p. 14)

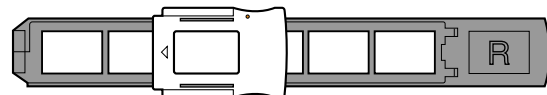

## IW-50 Film Viewer for IX240 Film

Place IX240 (Advanced Photo System) film in the IW-50 Film Viewer for insertion into the scanner.

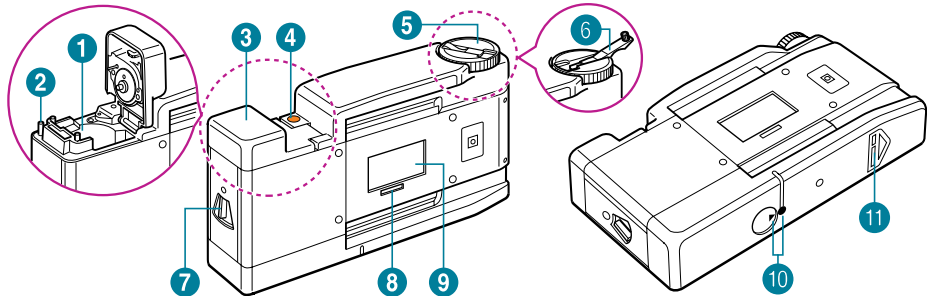

### 1 Cartridge Chamber

Place the IX240 film cartridge in here.

### 2 Exposure Tab

If the exposure tab, which indicates that the film in a cartridge has been developed when snapped down, has not been cleanly snapped, the film will free-wheel and not advance. Ensure that this tab is completely snapped.

### 3 Cartridge Chamber Cover

Open the cover by aligning the indicator marks **10** and pushing the open lever **7** to the open position. Closing it with or without a cartridge present will return the open lever to the closed position and lock it.

### 4 Film Indicator

An orange mark will display when the film is respooled and will disappear when it is unwound. The cartridge chamber cover **3** will not open even if the indicator marks **10** are correctly aligned unless the orange mark displays in the film indicator.

### 5 Winder

Turn the winder counterclockwise to unwind the film for viewing. Turn the winder clockwise to respool the film. A mistakenly inserted cartridge with undeveloped film will free-wheel and not unwind.

### 6 Crank

The crank is useful for speeding up unwinding and respooling.

### 7 Open Lever

This lever opens the cartridge chamber cover **3**. The lever will not operate unless the film is respooled (orange mark displayed in the film indicator **4**). When the chamber is empty, the indicator marks **10** must be aligned for the lever to operate.

### 8 Film Counter Window

Displays the number of the frame appearing in the scan window **9**.

### 9 Scan Window

The contents of this window will be scanned. Use the winder **5** and crank **6** to align images within this window for scanning.

### 10 Indicator Marks

These marks must be aligned so that the cartridge chamber cover **3** can be opened with the open lever **7**.

### 11 Insertion Arrow

Insert a loaded IW-50 Film Viewer into the film scanner with the insertion arrow on top and pointing into the scanner.

## WARNING

- The insertion arrow label **11** is not applied to the film viewer when shipped. Apply the supplied label to the label position on the film viewer before using the unit.

# Connecting to a Computer

This topic discusses USB connectors and methods for connecting more than one USB device to your computer.

## What is the USB Interface?

USB, the acronym for universal serial bus, is an interface for connecting various peripheral devices to your computer. It is easier to use than the serial and parallel interfaces that were widely used before the debut of the USB interface because it allows devices to be hot-swapped (attached or detached with the power on) and the connection and settings adjustments are simple. The USB interface can also accommodate a large number of devices (up to 127). This scanner supports the USB interface for Windows 98 SE, Windows 2000, and Windows Me, as well as for Macintosh computers (Mac OS 8.6 or higher) equipped with built-in USB ports.

## USB Connectors

There are two types of USB connector: A (flat, larger) and B (almost square, smaller). The A type is generally reserved for the computer's USB port and the B for the device port.

**A Type Connector**  
Used for the computer's USB port

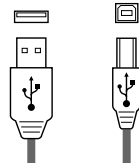

**B Type Connector**  
Used for the device's USB port

## Connecting Multiple USB Devices

When the USB ports on a computer are already in use, additional USB devices can be connected to an unoccupied USB port on one of the devices or to a USB hub (a device that expands a single port in several). Please note, however, that the scanner performance is not guaranteed when connected via a USB hub.

**Configuration Without a USB Hub**



**Configuration With a USB Hub**

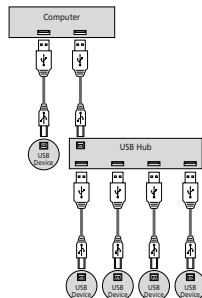

**USB Hub**  
A device for expanding the number of USB ports

The number of connectable devices can be gradually expanded by attaching additional hubs together until the maximum capacity is reached. However, all the devices may not be operable at once.

# Inserting Film

## 35 mm Negative and Positive Film (Sleeve Type)

Load 35 mm negative films and positive films that haven't been slide mounted into the film holder for insertion into the film scanner.

1. Have the film and film holder at hand.
2. Slide the guide on the film holder to the 'R' position.
  - Slide the guide all the way until it rests against the stopper.

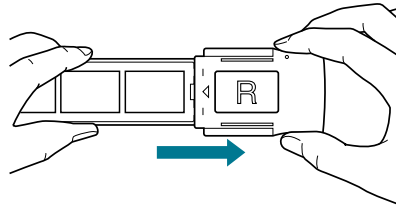

3. Open the film holder.
  - Gently twist the tab at the end of the film holder and open one half as shown.

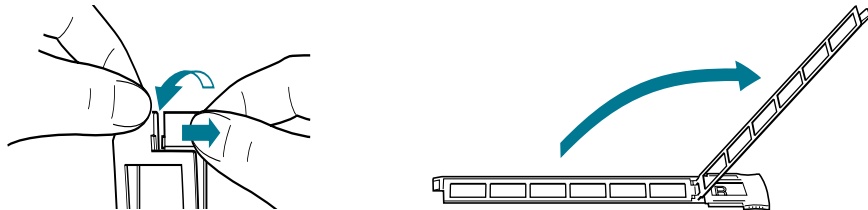

4. Load the film into the holder.
  - Place the film face up in the groove so that the image is viewed correctly when the 'R' on the film holder is facing up.

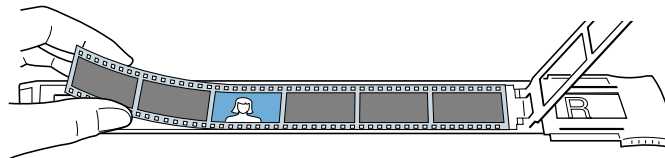

### NOTE

- The orientation of an image can be corrected with the rotate command of the scanning software, CanoCraft FSU or Plug-in Module FSU, if the film is incorrectly loaded.
- Read the section entitled *Final Film Format* (p. 25) for information regarding film mounts and sleeves.

### 5. Close the film holder.

- Align the ends of the holder and lightly pinch them together until they lock.

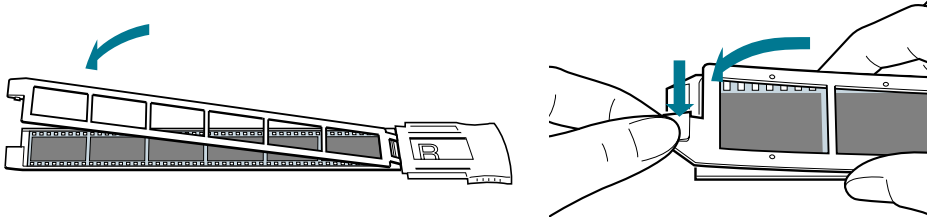

- After you have locked the ends, squeeze and run your fingers along the middle portion to prevent the film from floating.

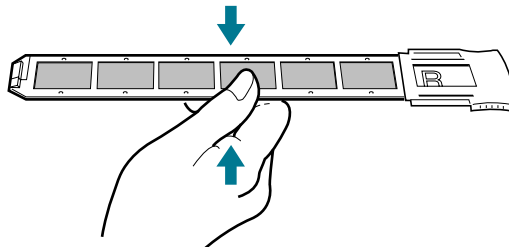

### 6. Position the guide over the frame to be scanned.

- The guide will click into indents in the holder marking the correct position for scanning as you slide it back and forth. Ensure that the tabs on the guide click into the indents and that the image is correctly framed by the guide.

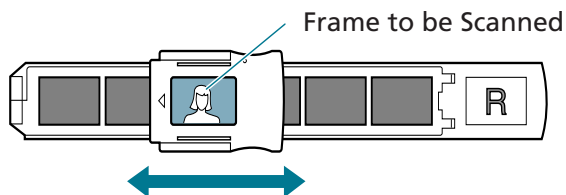

### WARNING

- Reload the film in the film holder if its edges stick out of the holder or the guide's movement is impeded.

### 7. Open the dust cover.

- Insert your fingertips into the notch on either side of the dust cover and pull it gently down.

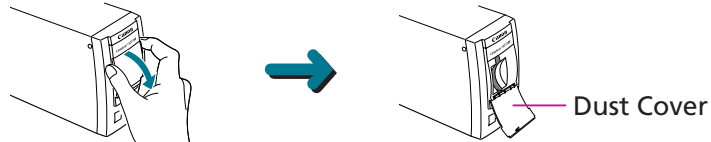

### 8. Insert the film holder into the scanner.

- Hold the film holder horizontally on edge as shown below, orienting it so that the orange mark is on the left side. Insert it straight into the scanner until the orange mark on the guide lines up with the orange mark on the scanner.

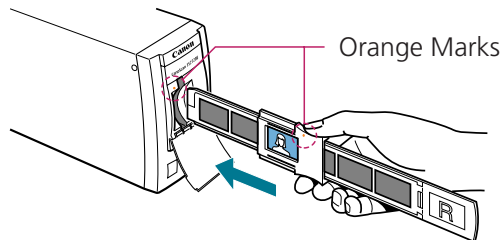

### WARNING

- If the film holder is inserted at an angle, the guide position may be altered and you may not be able to insert it properly.
- Ensure that the film holder is oriented according to the diagram below so that the guide is correctly inserted. The film holder will not fit correctly into the slot if the guide is incorrectly oriented.

#### Viewed from Above

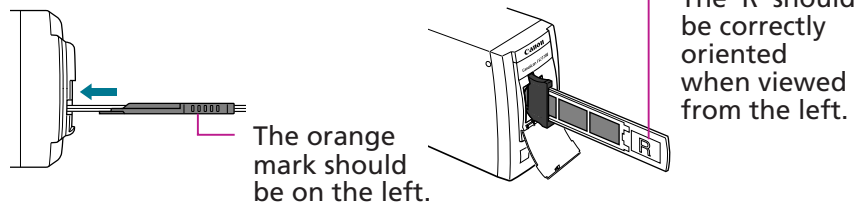

### NOTE

- Film holders can be purchased separately if the supplied one is broken or damaged. Inquire at the distributor from which you purchased the scanner.



## 35 mm Positive Film (Mounted Slides)

- Follow the procedures below to insert mounted positive films (mounted slides) directly into the scanner.

### 1. Open the dust cover.

- Using your fingertips, grasp the notch on either side of the dust cover and pull it gently down.

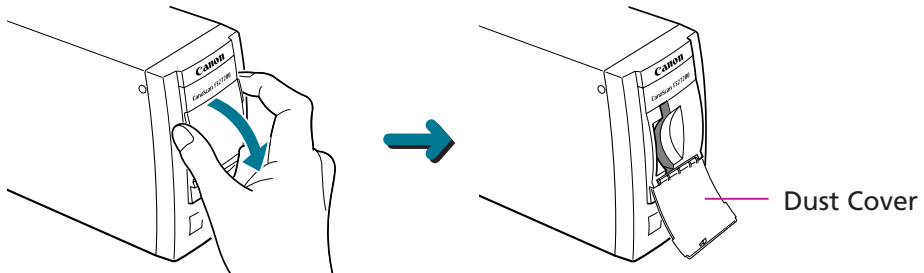

### 2. Insert the slide into the scanner, orienting it so that the image is correctly viewed from the left.

- Insert the slide as far as it will go.

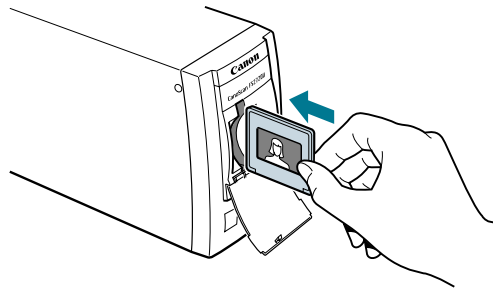

### WARNING

- The image will not be correctly scanned if the slide is inserted at an angle.
- Insert the slide so that the short edge faces the film guide.
- If a slide is inserted at an angle and becomes jammed in the slot, open the film guide and remove it.

### NOTE

- The orientation of an image can be corrected with the rotate command of the scanning software, CanoCraft FSU or Plug-in Module FSU, if the slide is reversed or inverted.

## IX240 Film

Follow the procedures below to load an IX240 film cartridge in the film viewer for insertion into the scanner.

### 1. Have the IX240 film cartridge at hand.

- Confirm that the cartridge has been developed by looking at the development mark and the exposure tab. The exposure tab should have been snapped downward.

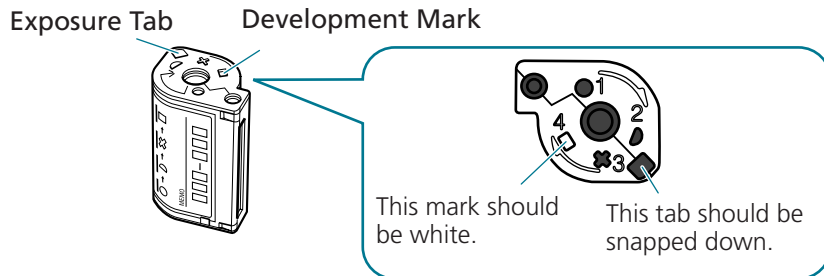

### WARNING

- Only IX240 films in cartridges and slide mounts can be scanned with the CanoScan FS2720U. It will not accept sleeve-type IX240 film.
- Undeveloped IX240 film cartridges that are mistakenly placed in the IW-50 Film Viewer will not unwind.

### 2. Confirm that the film viewer's film indicator is orange.

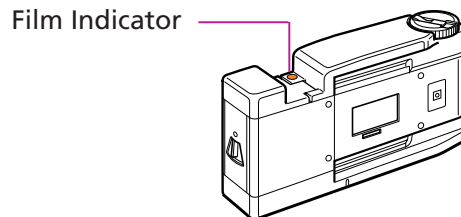

### WARNING

- If the film indicator is not orange, a cartridge is already loaded in the film viewer. Respool the film and remove the cartridge to make way for the cartridge you are scanning. (p. 22)

- 3 Turn the winder to align the indicator marks.

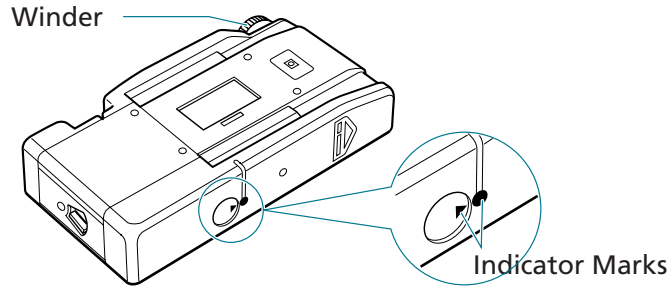

- 4 Push the open lever to the open position.  
The cartridge chamber cover will open.

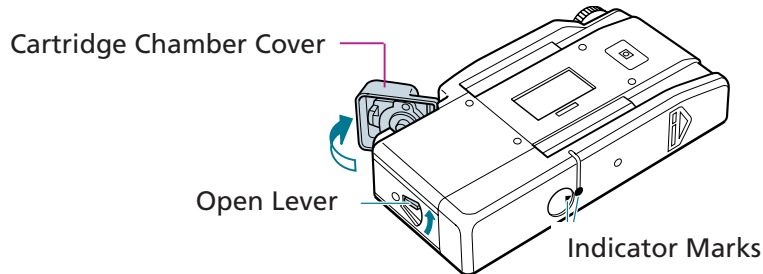

### WARNING

- The open lever will not operate unless the indicator marks are aligned.

- 5 Insert the cartridge into the chamber with the development mark facing upward. Close the cover.

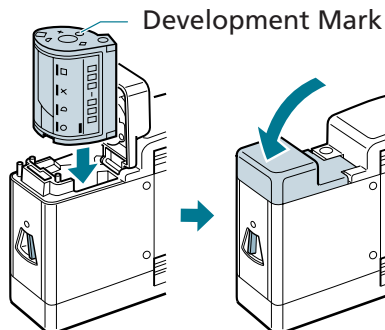

### WARNING

- The cartridge will not fit into the chamber unless it is correctly oriented.
- Close the cartridge chamber cover all the way until it locks into place with a click.

6. Turn the winder counterclockwise until the image you wish to scan appears in the scan window.

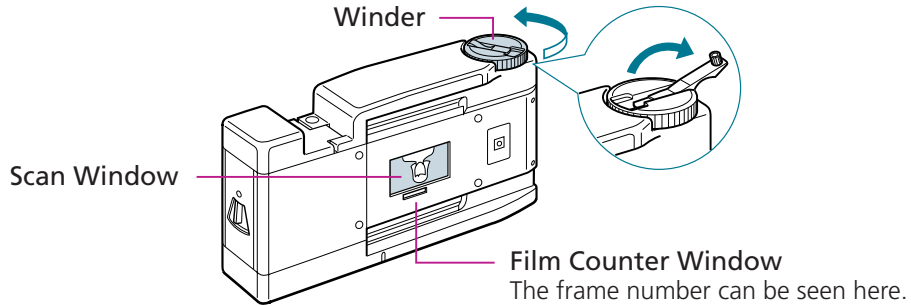
**NOTE**

*The crank is useful for speeding up unwinding and respooling.*

7. Turn the film viewer upside-down so that the insertion arrow is on the top.

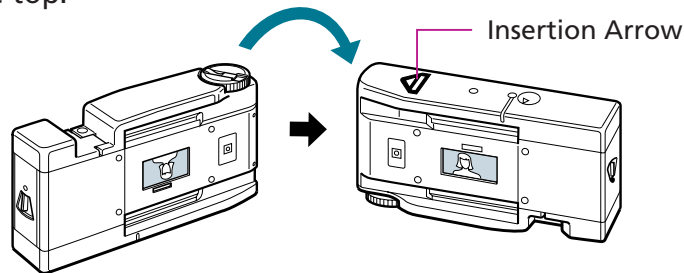

8. Open the film guide on the scanner. Insert the loaded film viewer.
- Orient the film viewer so that the insertion arrow is on top and pointing toward the scanner. Insert it as far as it will go into the scanner until it rests against the end.

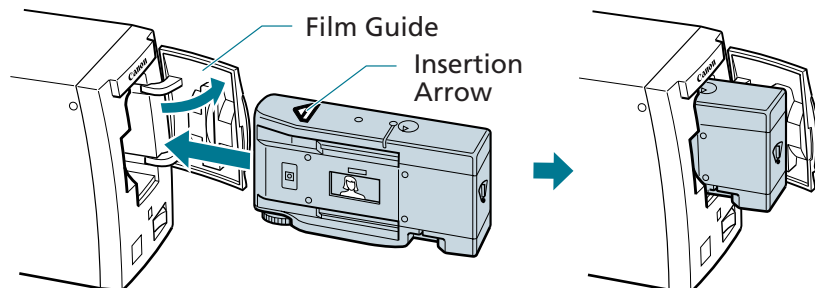

**WARNING**

- *The film viewer will not enter the film scanner if the crank handle is protruding. Confirm that the crank is fully retracted before attempting to insert the film viewer.*
- *Ensure that you pull the film viewer straight out of the scanner without tilting it.*

**NOTE**

- *Film viewers can be purchased separately if the supplied one is broken or damaged. Inquire at the distributor from which you purchased the scanner.*

Exercise due caution with regard to the following when replicating images.

- Copying paper currency, coins and negotiable securities is an offense and subject to criminal prosecution.
- The unauthorized duplication of identification materials, licenses, travel tickets, official documents or private materials is against the law and subject to criminal prosecution.
- Copyrighted material may not be duplicated without permission of the copyright holder except for use by an individual or within the confines of their own residence or a limited area.

## IX240 Film Cartridge Removal

Follow the procedures below to remove IX240 film cartridges from the film viewer.

1. Turn the winder clockwise to completely respool the film.
  - The film indicator will show orange when the film is completely respooled.

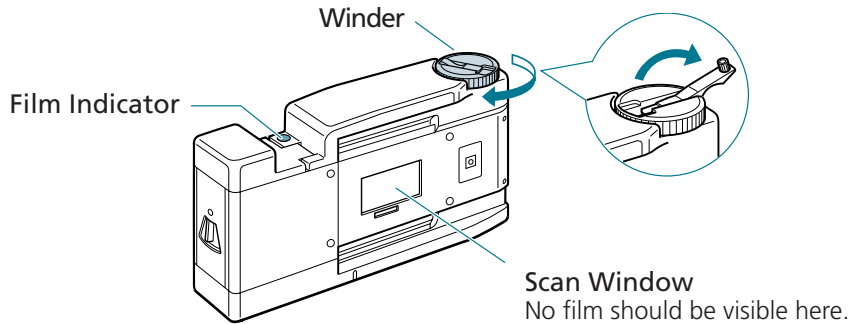

2. Turn the winder to align the indicator marks.

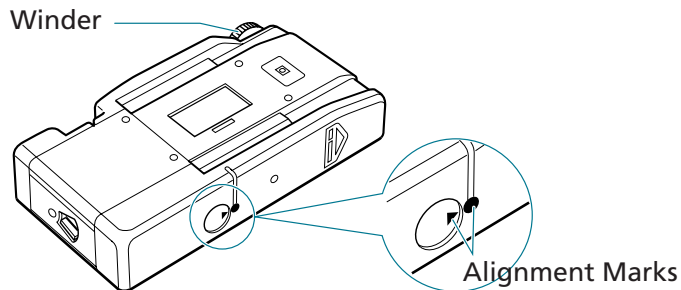

3. Push the open lever to the open position to open the cartridge chamber cover. Remove the cartridge.

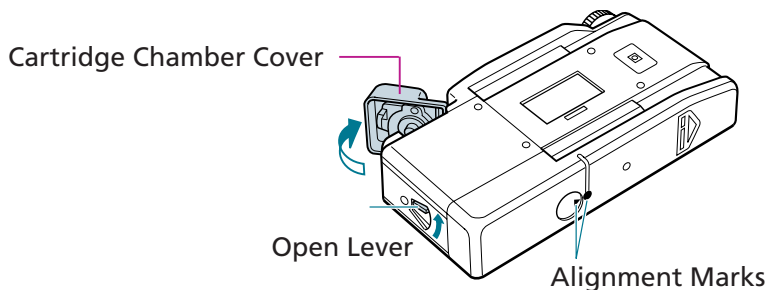

## Basic Information About Film

This section describes the available varieties and characteristics of various types of film. This information is useful when choosing film format and development options.

### Film Varieties

The most common format is 35 mm film (135 film). Recently, a new format has been launched. IX240 film complying to Advanced Photo System standards is compact, simple to handle and equipped with a range of new features.

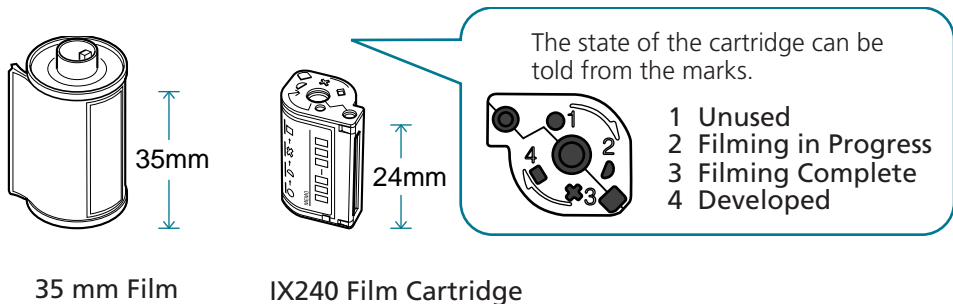

The CanoScan FS2720U accepts both types of film for scanning. Please select the film that matches your camera.

Films in the 4x5, 120 or 220 roll film or similar formats cannot be scanned in the CanoScan FS2720U. The scanner accepts 35 mm films in sleeves or slide mounts and IX240 film in cartridges or slide mounts. Please read the section entitled Final Film Format (p. 25) for information regarding film mounts and sleeves.

### Color/Monochrome Film

Films are available in color or monochrome formats. The CanoScan FS2720U accepts both and can even reproduce color films in the monochrome format.

## Negative/Positive Film

---

### Color Negative Film



Negative film is used to make prints. The light and dark portions of the film are reversed from the image. It permits a large degree of latitude (the extent to which it is under- or over-exposed) so that even if a picture is slightly under- or over-exposed (the amount of light striking the film) when shot, the problem can be corrected by the developer when printed to paper. The negative film format is recommended when you wish to shoot without being strictly conscious of the exposure setting or when you wish to have the picture output as prints. However, the color of the film base (the color of the film itself) varies somewhat between manufacturers and between individual products. For this reason, the CanoScan FS2720U has to utilize a color correction process to reproduce colors correctly. This process is conducted automatically by the CanoScan FS2720U auto color balance function.

### Color Positive Film



Positive film (reversal film) reproduces the colors on film as they are on the photographic subject so that the colors of a photographed object are immediately apparent. This format is used when the pictures are viewed as slides or when printing plates are being made. Compared to negative film, the latitude of positive film is narrow, requiring the photographer to pay more attention to the exposure setting. Since there is no effect on color reproduction because of differing film base colors, the CanoScan FS2720U does not need to perform its auto color balance function on films in this format.



## Final Film Format

When you ask for a 35 mm film to be developed, you can order it to be mounted in a sleeve or in a slide mount. Similarly, IX240 film can be ordered in a sleeve, slide mount or cartridge format.

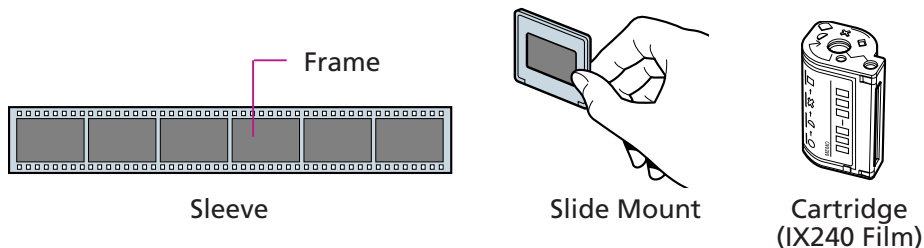

The standard format for 35 mm negative film is a six-frame sleeve. Positive film can be ordered in either a six-frame sleeve or slide mounts. IX240 film is normally developed in the cartridge format, eliminating the need to specify a format. The CanoScan FS2720U accepts 35 mm film sleeves and slide mounts and IX240 film slide mounts and cartridges for scanning. Select any of these four formats to suit your convenience.

Film Type		Final Film Format	Formats Accepted by the CanoScan FS2720U
Positive	35 mm Film	Sleeve	o
		Slide Mount	o
	IX240 Film	Sleeve	x
		Slide Mount	o
Negative	35 mm Film	Cartridge	o
		Sleeve	o
	IX240 Film	Cartridge	o

## Care and Maintenance

Follow the procedures below to clean dirt and dust off the exterior of the scanner.

1. Turn off the computer and peripheral devices, including the scanner.
2. Unplug the scanner's power cord, grasping it by the solid portion of the plug.
3. Moisten a soft cloth with water and wring it well.  
Wipe off the dirt and dust.
  - Do not wet the connectors or metal parts of the back panel. Ensure that you wipe these parts with a dry cloth if they should get wet.
  - Do not wipe the equipment with an extremely wet cloth and do not spray cleansers or water directly onto it. There is a risk that liquids could enter the interior and degrade image quality or cause malfunctions or accidents.
  - Never apply alcohol, thinners or benzene to the equipment. These substances may distort, discolor or dissolve the casing.
4. Wipe off all moisture with a soft, dry cloth.
  - Ensure that all moisture is removed from the unit.

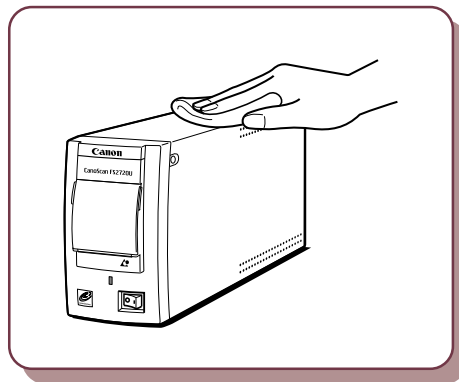

Never apply alcohol, thinners or benzene to the equipment.

## Cleaning Film

Follow the procedures below to clean films if they become dirty or dusty.

### Dirty Film

Wipe the film lightly with a clean eyeglass lens cleaning cloth.

- Do not wipe forcefully. Strong wiping will damage the film.
- Never apply water, alcohol, thinners, benzene or other chemicals to the film. These substances will cause the emulsion to peel, or alter or dissolve the film.

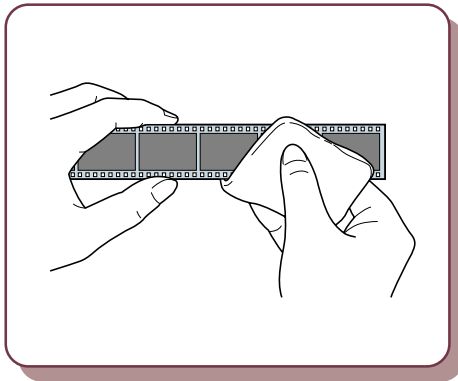

Never apply alcohol, thinners, benzene or other chemicals to film.

### Dusty Film

Hold the film lightly by the edges and remove the dust with a blower brush.

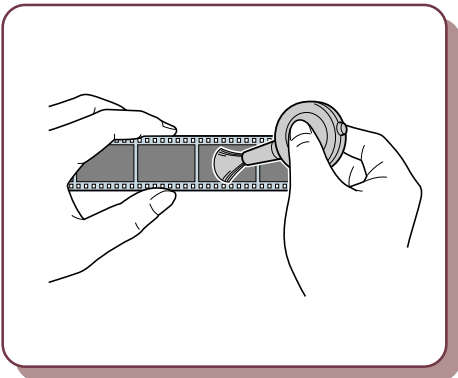

## Specifications

Type	Moving Film Carriage/Desktop Model	
Scanning Element	Charge-Coupled Device 3-Line Color Image Sensor	
Light Source	White Cold-Cathode Xenon Lamp	
Scanning Resolution	2720 dots per inch	
Scanning Modes	Color/Grayscale/Black and White	
Scanning Gradation	12-Bit Scanning/8-Bit or 12-Bit Output	
Maximum Scanning Density	3.2	
Scanning Speed	35 mm Positives	13/20/25 seconds* (Switchable)
	35 mm Negatives	13/26/39/52/78 seconds* (Switchable)
	IX240 Positives	10/15/20 seconds* (Switchable)
	IX240 Negatives	10/20/30/40/60 seconds* (Switchable)
Effective Scanning Area	35 mm Film	24.0 x 36.0 mm ± 1 mm
	IX240 Film	17.4 x 31.3 mm ± 1 mm
Focal Modes	Auto/Manual	
Prescan Speed	7 seconds/175 dots per inch, positives	
Magnification	5~200%	
Interface	USB	
Power Supply	100~240 V AC, 50~60 Hz	
Maximum Power Consumption	Standby: >18 Watts	
	Operating: >30 Watts	
Dimensions (w x l x h)	85 x 321 x 147 mm (3.3 x 12.6 x 5.8 in.)	
Weight	Approximately 2.1 kg (4.6 lbs)	

These specifications may change without notice.

\* Times do not include transmission time to the computer.

# Index

## A

- Advanced Photo System 5
- Auto Color Balance 5
- Autofocus 5

## C

- Care and Maintenance 26
- Cartridge 18, 25
  - Chamber 12
  - Chamber Cover 12, 19
  - Removing the 22
- Cleaning
  - Film 27
  - the Exterior 26
- Clear Space Requirements 9
- Color Film 23
- Components Guide 11
- Crank 12

## D

- Development Mark 18, 19
- Dust Cover 11, 17

## E

- Exposure Tab 18

## F

- Film
  - Guide 11
  - Counter Window 12, 20
  - Format 23
  - Indicator 18
  - Inserting 14
  - Mounts 25
  - Types 25
- Final Film Format 25

## G

- General Handling Precautions 8

## I

- Insertion Arrow 12, 20
- IW-50 Film Viewer 12, 18
- IX240
  - Film 12, 18, 23, 25
  - Film Cartridge Removal 22

## M

- Monochrome Film 23
- Mounted Slides 17
- Mount 25

## N

- Negative Film 24

## O

- Open Lever 12, 19
- Orange Mark 12, 16

## P

- Placement Precautions 6
- Positive Film 24
- Power
  - Cord Socket 11
  - Indicator 11
  - Supply Precautions 7
  - Switch 11

## R

- R Position 14
- Respooling Film 12

## S

- Safe Locations 9
- Safety Instructions 6
- Scan Window 12
- Sleeve 14, 25
- Specifications 28

## T

- 35 mm
  - Film 23
  - Film Holder 11, 14
  - Negative Film 14
  - Positive Film 14, 17

## U

- Unwinding Film 12
- USB
  - Connector 13
  - Hub 13
  - Interface 13
  - Port 11, 13

## W

- Winder 12



### **Caution**

1. No part of this document may be reproduced or transmitted in any form or by any means, electronic or mechanical, for any purpose, without the express written permission of Canon Inc.
2. The equipment and software described in this guide are subject to change without notice.
3. Notwithstanding the considerable care taken in preparing this guide, please note that Canon Inc. does not accept liability for any results arising from the operation of the equipment or software mentioned herein.
4. Please note that scanning copyrighted materials, including documents and images, without permission from the copyright holder is prohibited by law, except for personal or household use.
5. Portions of this guide are reproduced herein with the permission of Abode Systems Incorporated.

### **Trademark Acknowledgment**

- Adobe and Acrobat are trademarks of Adobe Systems Incorporated.
- IBM, IBM PC/AT Series are trademarks of International Business Machines Corp., USA.
- Windows is a registered trademark of Microsoft Corporation in the United States and/or other countries.
- Macintosh is a trademark of Apple Computer, Inc.
- All other brand names and product names used in this manual are trademarks or registered trademarks of their respective holders.

## Free Manuals Download Website

<http://myh66.com>

<http://usermanuals.us>

<http://www.somanuals.com>

<http://www.4manuals.cc>

<http://www.manual-lib.com>

<http://www.404manual.com>

<http://www.luxmanual.com>

<http://aubethermostatmanual.com>

Golf course search by state

<http://golfingnear.com>

Email search by domain

<http://emailbydomain.com>

Auto manuals search

<http://auto.somanuals.com>

TV manuals search

<http://tv.somanuals.com>