

iPF710

SERVICE MANUAL



Canon

DU7-1244-000

**OCTOBER 2007
REV. 0**

Application

This manual has been issued by Canon Inc. for qualified persons to learn technical theory, installation, maintenance, and repair of products. This manual covers all localities where the products are sold. For this reason, there may be information in this manual that does not apply to your locality.

Corrections

This manual may contain technical inaccuracies or typographical errors due to improvements or changes in products. When changes occur in applicable products or in the contents of this manual, Canon will release technical information as the need arises. In the event of major changes in the contents of this manual over a long or short period, Canon will issue a new edition of this manual.

The following paragraph does not apply to any countries where such provisions are inconsistent with local law.

Trademarks

The product names and company names used in this manual are the registered trademarks of the individual companies.

Copyright

This manual is copyrighted with all rights reserved. Under the copyright laws, this manual may not be copied, reproduced or translated into another language, in whole or in part, without the written consent of Canon Inc.

COPYRIGHT © 2001 CANON INC.









Printed in Japan

Caution

Use of this manual should be strictly supervised to avoid disclosure of confidential information.



Symbols Used

This documentation uses the following symbols to indicate special information:

Symbol	Description
	Indicates an item of a non-specific nature, possibly classified as Note, Caution, or Warning.
	Indicates an item requiring care to avoid electric shocks.
	Indicates an item requiring care to avoid combustion (fire).
	Indicates an item prohibiting disassembly to avoid electric shocks or problems.
	Indicates an item requiring disconnection of the power plug from the electric outlet.
 Memo	Indicates an item intended to provide notes assisting the understanding of the topic in question.
 REF.	Indicates an item of reference assisting the understanding of the topic in question.
	Provides a description of a service mode.
	Provides a description of the nature of an error indication.

The following rules apply throughout this Service Manual:

1. Each chapter contains sections explaining the purpose of specific functions and the relationship between electrical and mechanical systems with reference to the timing of operation.

In the diagrams,  represents the path of mechanical drive; where a signal name accompanies the symbol, the arrow  indicates the direction of the electric signal.

The expression "turn on the power" means flipping on the power switch, closing the front door, and closing the delivery unit door, which results in supplying the machine with power.

2. In the digital circuits, '1' is used to indicate that the voltage level of a given signal is "High", while '0' is used to indicate "Low". (The voltage value, however, differs from circuit to circuit.) In addition, the asterisk (*) as in "DRMD*" indicates that the DRMD signal goes on when '0'.

In practically all cases, the internal mechanisms of a microprocessor cannot be checked in the field. Therefore, the operations of the microprocessors used in the machines are not discussed: they are explained in terms of from sensors to the input of the DC controller PCB and from the output of the DC controller PCB to the loads.

The descriptions in this Service Manual are subject to change without notice for product improvement or other purposes, and major changes will be communicated in the form of Service Information bulletins. All service persons are expected to have a good understanding of the contents of this Service Manual and all relevant Service Information bulletins and be able to identify and isolate faults in the machine."

Contents

Chapter 1 PRODUCT DESCRIPTION

1.1 Product Overview	1-1
1.1.1 Product Overview	1-1
1.2 Features	1-2
1.2.1 Features	1-2
1.2.2 Printhead	1-2
1.2.3 Ink Tank	1-3
1.2.4 Cutter unit	1-3
1.2.5 Roll Holder	1-3
1.2.6 Stand	1-4
1.2.7 IEEE1394 (FireWire) Board	1-5
1.2.8 Consumables	1-5
1.3 Product Specifications	1-7
1.3.1 Product Specifications	1-7
1.4 Detailed Specifications	1-10
1.4.1 Print Speed and Direction	1-10
1.4.2 Interface specifications	1-17
1.5 Names and Functions of Components	1-18
1.5.1 Front	1-18
1.5.2 Rear	1-19
1.5.3 Carriage	1-20
1.6 Basic Operation	1-21
1.6.1 Operation Panel	1-21
1.6.2 Main Menu	1-22
1.7 Safety and Precautions	1-40
1.7.1 Safety Precautions	1-40
1.7.1.1 Moving Parts	1-40
1.7.1.2 Adhesion of Ink	1-41
1.7.1.3 Electric Parts	1-42
1.7.2 Other Precautions	1-44
1.7.2.1 Printhead	1-44
1.7.2.2 Ink Tank	1-45
1.7.2.3 Handling the Printer	1-46
1.7.3 Precautions When Servicing Printer	1-48
1.7.3.1 Notes on the Data Stored in the Printer	1-48
1.7.3.2 Confirming the Firmware Version	1-48

1.7.3.3 Precautions against Static Electricity 1-48
1.7.3.4 Precautions for Disassembly/Reassembly..... 1-49
1.7.3.5 Self-diagnostic Feature 1-49
1.7.3.6 Disposing of the Lithium Battery 1-49

Chapter 2 TECHNICAL REFERENCE

2.1 Basic Operation Outline 2-1
 2.1.1 Printer Diagram 2-1
 2.1.2 Print Signal Sequence 2-2
 2.1.3 Print Driving 2-3
2.2 Firmware 2-6
 2.2.1 Operation Sequence at Power-on 2-6
 2.2.2 Operation Sequence at Power-off 2-7
 2.2.3 Print Control 2-8
 2.2.4 Print Position Adjustment Function 2-14
 2.2.5 Head Management 2-14
 2.2.6 Printhead Overheating Protection Control 2-14
 2.2.7 Pause between Pages 2-15
 2.2.8 White Raster Skip 2-15
 2.2.9 Sleep Mode 2-15
2.3 Printer Mechanical System 2-16
 2.3.1 Outline 2-16
 2.3.1.1 Outline 2-16
 2.3.2 Ink Passage 2-17
 2.3.2.1 Ink Passage 2-17
 2.3.2.2 Ink Tank Unit 2-19
 2.3.2.3 Carriage Unit 2-22
 2.3.2.4 Printhead 2-25
 2.3.2.5 Purge Unit 2-26
 2.3.2.6 Maintenance Cartridge 2-32
 2.3.2.7 Air Flow 2-33
 2.3.3 Paper Path 2-33
 2.3.3.1 Outline 2-33
 2.3.3.2 Paper Path 2-35
 2.3.3.3 Cutter Unit 2-36
2.4 Printer Electrical System 2-37
 2.4.1 Outline 2-37
 2.4.1.1 Overview 2-37
 2.4.2 Main Controller 2-39
 2.4.2.1 Main controller components 2-39
 2.4.3 Carriage Relay PCB 2-41
 2.4.3.1 Carriage relay PCB components 2-41
 2.4.4 Head Relay PCB 2-41

2.4.4.1 Head relay PCB components	2-41
2.4.5 Maintenance Cartridge Relay PCB	2-42
2.4.5.1 Maintenance cartridge relay PCB components	2-42
2.4.6 Power Supply	2-42
2.4.6.1 Power supply block diagram	2-42
2.5 Detection Functions with Sensors	2-43
2.5.1 Sensors for covers	2-43
2.5.2 Ink passage system	2-44
2.5.3 Carriage system	2-47
2.5.4 Paper path system	2-49

Chapter 3 INSTALLATION

3.1 Transporting the Printer	3-1
3.1.1 Transporting the Printer	3-1
3.1.1.1 Transporting the Printer	3-1
3.1.2 Reinstalling the Printer	3-4
3.1.2.1 Reinstalling the Printer	3-4

Chapter 4 DISASSEMBLY/REASSEMBLY

4.1 Service Parts	4-1
4.1.1 Service Parts	4-1
4.2 Disassembly/Reassembly	4-1
4.2.1 Disassembly/Reassembly	4-1
4.3 Points to Note on Disassembly and Reassembly	4-3
4.3.1 Note on locations prohibited from disassembly	4-3
4.3.2 Moving the carriage manually	4-3
4.3.3 Units requiring draining of ink	4-3
4.3.4 External Covers	4-4
4.3.5 Waste Ink Box	4-11
4.3.6 Driving Unit	4-12
4.3.7 Ink Tube Unit	4-13
4.3.8 Carriage Unit	4-16
4.3.9 Feeder Unit	4-21
4.3.10 Purge Unit	4-22
4.3.11 Ink Tank Unit	4-23
4.3.12 Head Management Sensor	4-25
4.3.13 Multi Sensor	4-26
4.3.14 PCBs	4-27
4.3.15 Opening the Cap/Moving the Wiper Unit	4-28
4.3.16 Opening/Closing the Ink Supply Valve	4-29

4.3.17 Draining the Ink	4-30
4.4 Applying the Grease	4-31
4.4.1 Applying the Grease	4-31
4.5 Adjustment and Setup Items	4-33
4.5.1 Adjustment Item List	4-33
4.5.2 Procedure after Replacing the Feed Roller or Feed Roller Encoder	4-33
4.5.3 Procedure after Replacing the Carriage Unit or Multi Sensor	4-33
4.5.4 Procedure after Replacing the Head Management Sensor	4-34

Chapter 5 MAINTENANCE

5.1 Periodic Replacement Parts	5-1
5.1.1 Periodic Replacement Parts	5-1
5.2 Consumable Parts	5-1
5.2.1 Consumable Parts	5-1
5.3 Periodic Maintenance	5-2
5.3.1 Periodic Maintenance	5-2

Chapter 6 TROUBLESHOOTING

6.1 Troubleshooting	6-1
6.1.1 Outline	6-1
6.1.1.1 Outline of Troubleshooting	6-1
6.2 Location of Connectors and Pin Arrangement	6-2
6.2.1 Main controller PCB	6-2
6.2.2 Carriage relay PCB	6-12
6.2.3 Head relay PCB	6-19
6.3 Version Up	6-24
6.3.1 Firmware Update Tool	6-24
6.4 Service Tools	6-25
6.4.1 Tool List	6-25
6.4.2 Using the Cover Switch Tool	6-26

Chapter 7 SERVICE MODE

7.1 Service Mode	7-1
7.1.1 Service Mode Operation	7-1
7.1.2 Map of the Service Mode	7-2
7.1.3 Details of Service Mode	7-10
7.1.4 Sample Printout	7-27
7.2 Special Mode	7-32
7.2.1 Special Modes for Servicing	7-32

Chapter 8 ERROR CODE

8.1 Outline.....	8-1
8.1.1 Outline.....	8-1
8.2 Warning Table	8-2
8.2.1 Warnings	8-2
8.3 Error Table	8-3
8.3.1 Error Code List	8-3
8.4 Sevice Call Table	8-6
8.4.1 Service call errors	8-6

Chapter 1 PRODUCT DESCRIPTION

Contents

1.1 Product Overview	1-1
1.1.1 Product Overview	1-1
1.2 Features	1-2
1.2.1 Features	1-2
1.2.2 Printhead	1-2
1.2.3 Ink Tank	1-3
1.2.4 Cutter unit	1-3
1.2.5 Roll Holder	1-3
1.2.6 Stand	1-4
1.2.7 IEEE1394 (FireWire) Board	1-5
1.2.8 Consumables	1-5
1.3 Product Specifications	1-7
1.3.1 Product Specifications	1-7
1.4 Detailed Specifications	1-10
1.4.1 Print Speed and Direction	1-10
1.4.2 Interface specifications	1-17
1.5 Names and Functions of Components	1-18
1.5.1 Front	1-18
1.5.2 Rear	1-19
1.5.3 Carriage	1-20
1.6 Basic Operation	1-21
1.6.1 Operation Panel	1-21
1.6.2 Main Menu	1-22
1.7 Safety and Precautions	1-40
1.7.1 Safety Precautions	1-40
1.7.1.1 Moving Parts	1-40
1.7.1.2 Adhesion of Ink	1-41
1.7.1.3 Electric Parts	1-42
1.7.2 Other Precautions	1-44
1.7.2.1 Printhead	1-44
1.7.2.2 Ink Tank	1-45
1.7.2.3 Handling the Printer	1-46
1.7.3 Precautions When Servicing Printer	1-48
1.7.3.1 Notes on the Data Stored in the Printer	1-48
1.7.3.2 Confirming the Firmware Version	1-48
1.7.3.3 Precautions against Static Electricity	1-48
1.7.3.4 Precautions for Disassembly/Reassembly	1-49
1.7.3.5 Self-diagnostic Feature	1-49
1.7.3.6 Disposing of the Lithium Battery	1-49

1.1 Product Overview

1.1.1 Product Overview

This printer is a large-format printer that prints in a maximum width of 36 inches with high-speed photographic picture quality.
This printer is a desktop product that delivers its output on roll media or cut sheets.

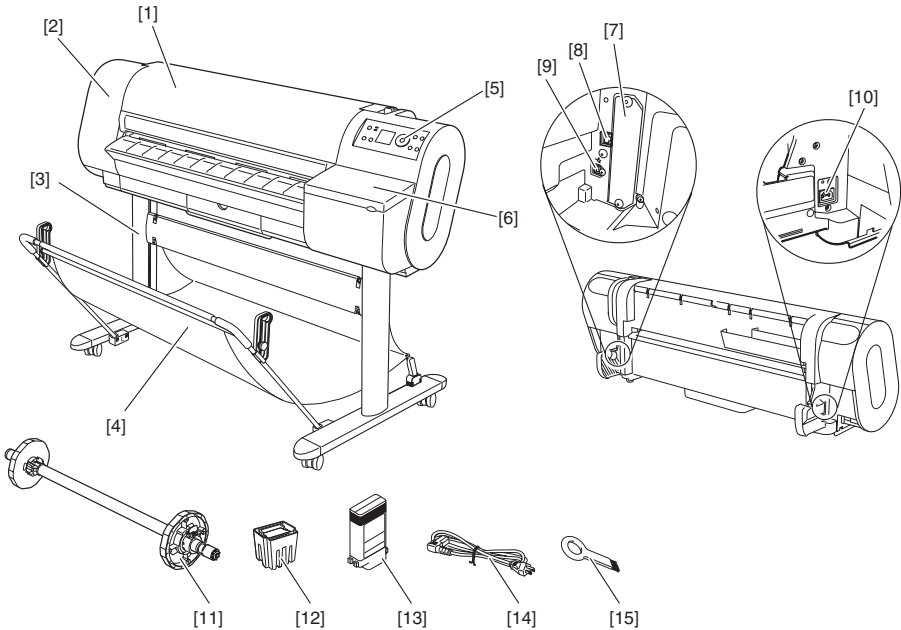

F-1-1

T-1-1

- | | |
|--|-----------------------------|
| [1] Top Cover | [9] USB Port |
| [2] Upper Left Cover | [10] Power Supply Connector |
| [3] Stand (option) | [11] Roll Holder Set |
| [4] Output Stacker (included with stand) | [12] Printhead |
| [5] Operation Panel | [13] Ink Tank |
| [6] Ink Tank Cover | [14] Power Cord |
| [7] Expansion Board Slot | [15] Cleaner Brush |
| [8] Ethernet Connector | |

1.2 Features

1.2.1 Features

- Rear loading of roll media, making for compact, lightweight device geometry.
- Borderless four-side printing support (roll media) removes laborious cutting work, easing the job of creating posters to a significant degree.
- High resolutions of 2400 x 1200 dpi maximum, coupled with the exceptionally light-fast, water-proof and ozone-proof five-color pigment inks of Y, M, C, BK and MBK, deliver high-quality photographic picture quality.
- High-speed printing under bidirectional print control.
- Ink supply through tubing to a completely independent printhead and large-capacity ink tanks.
- Ready for roll media and cut media.
- Roll media pass in widths between 254 and 914.4 mm and in lengths up to 18 m.
- The cutter unit that mounts on the carriage allows paper to be cut automatically.
- Cut media are fed and ejected and ink tanks replaced all in an easy-to-access front panel operation.
- USB2.0 high-speed interface and 10Base-T/100Base-TX in standard support of a TCP/IP network, plus optional support of IEEE1394.

1.2.2 Printhead

The printhead that mounts on the carriage is an integrated six-color disposable printhead. It has 5,120 nozzles for MBK and 2,560 nozzles for each additional color arranged in a zigzag pattern. If print quality remains unimproved even after a specified cleaning operation, replace the printhead. Replacement about one year after the date of initial unpacking is also recommended.

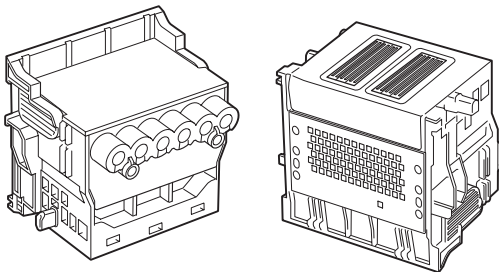

F-1-2

1.2.3 Ink Tank

Ink tanks are disposable.

An ink tank should be replaced when an ink tank replacement prompt message appears or when six months expire after the date of initial unpacking, whichever occurs earlier.

To install ink tanks, open the right cover of the printer. Ink tanks are furnished with a notch for preventing incorrect installation, which will allow the tanks to be installed at the position marked in the right color and nowhere else.

Ink tanks are available in the four dye ink colors of black, cyan, magenta and yellow and the pigment ink color of mat black.

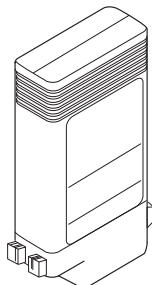

F-1-3

1.2.4 Cutter unit

The cutter unit that mounts on the carriage is disposable.

Replace the cutter unit when it gets dull.

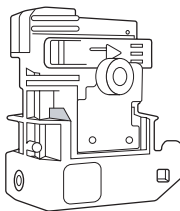

F-1-4

1.2.5 Roll Holder

The printer comes with a roll holder for 2-inch paper tube and 3-inch paper tube attachment.

The roll holder clamps the paper tubes of roll media with an outside diameter of 150 mm or less from inside.

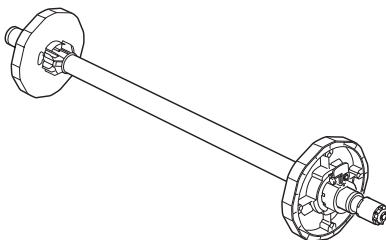

F-1-5

1.2.6 Stand

It is a stand that puts the printer. Equipped with casters so that the printer can be easily moved. The output stacker included with stand can use by the two ways of the regular position or extended position.

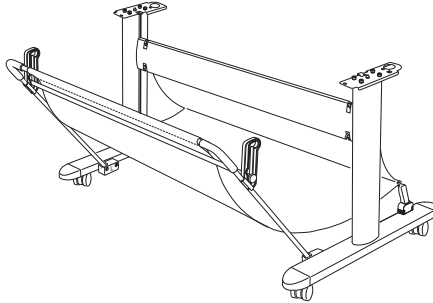

F-1-6

MEMO:

- Use the output stacker in the regular position [A]. However, for the specified media, it can also be used in the extended position [B]. The media can be removed more easily when the output stacker is in the extended position.
- The output stacker can accommodate one sheet. Remove each sheet before printing if you are printing a series of documents.

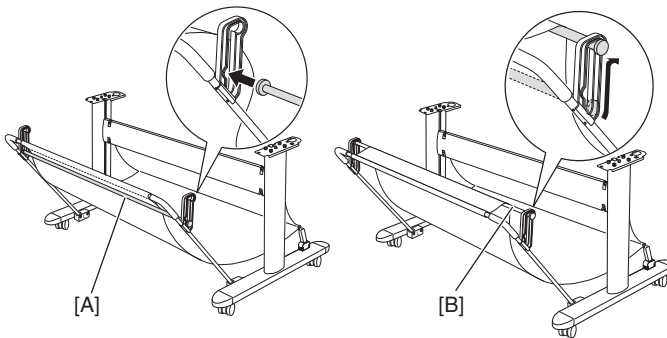

F-1-7

1.2.7 IEEE1394 (FireWire) Board

IEEE1394 (FireWire) expansion board (option)

An interface board that provides an additional IEEE1394 (FireWire) port.

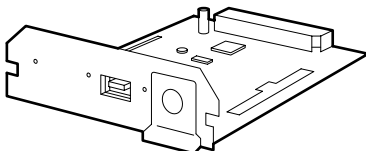

F-1-8

1.2.8 Consumables

a. Printhead

The expendable printhead is the same as the one that comes with the printer.

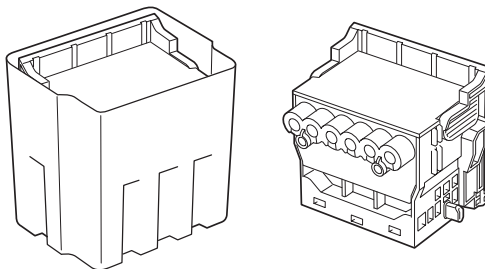

F-1-9

b. Ink Tanks

The expendable ink tanks are available in five colors: mat black, black, cyan, magenta and yellow. They are the same the same as the ones that come with the printer. Usable for six months after unpacking. The ink tank that can be used with this printer is labeled "A".

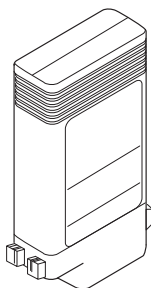

F-1-10

c. Maintenance cartridge

The expendable maintenance cartridge is the same as the one that comes with the printer.
The maintenance cartridge is furnished with a shaft cleaner.

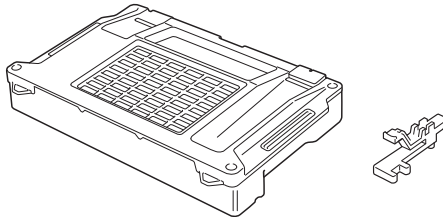

F-1-11

1.3 Product Specifications

1.3.1 Product Specifications

Type	Bubble-jet printer (desktop type)
Feeding system	Roll media: Manual (Rear loading) Cut media: Paper tray (Front loading)
Feeding capacity	Roll media: 1 roll (up to 150mm in outside diameter)/Inner diameter of paper tube: 2 or 3 inches Cut media: 1 sheet
Delivery method	Delivers the media with its printed side up in the forward direction.
Sheet delivery capability	1 sheet (collected in a output stacker)
Cutter	[CT-05] Auto-cutter with replaceable cartridges
Type of media	Plain Paper, Plain Paper(High Quality), Plain Paper(High Grade), All Plain Paper_Conserve MBK, Coated Paper, Heavyweight Coated Paper, Premium Matte Paper, Glossy Photo Paper, Semi-Glossy Photo Paper, Recycled Coated Paper, Extra Heavyweight Coated Paper, Heavyweight Glossy Photo Paper 2, Heavywght SemiGlos Photo Paper 2, Satin Photographic Paper 190gsm, Synthetic Paper, Adhesive Synthetic Paper, Proofing Paper, Colored Coated Paper, CAD Tracing Paper, CAD Translucent Matte Film, CAD Clear Film, Newsprint for Proofing1, Newsprint for Proofing2, Economy Bond Paper, Universal Bond Paper, Premium Coated Paper, Matte Coated Paper 90gsm, Glossy Photographic Paper 190gsm, Glossy Photographic Paper 240gsm, Satin Photographic Paper 240gsm, HW Glossy Photo Paper, HW Satin Photo Paper, Premium RC Photo Luster, Commercial Proofing Paper, Commercial RC Proofing 210gsm, Commercial RC Proofing 270gsm
Supported thickness	0.07mm to 0.8mm
Media size (Roll media)	Width: 254mm to 914.4mm Length: 203.2mm to 18m (Roll media up to 150 mm in outside diameter)
Media size (Cut sheet)	Width: 203.2mm to 917mm Length: 203.2mm to 1600mm

Printable area (Roll media)	<p>Bordered printing: Internal area, excluding 3mm top, bottom, and left and right margins.</p> <p>Borderless printing: Internal area, excluding 0mm top, bottom, and left and right margins.</p> <p>* The printable area may vary with each type of paper media used.</p> <p>Width of media allowing borderless printing: 36"(914mm), A0(841mm), B1(728mm), 24"(610mm), A1(594mm), B2(515mm), 16"(407mm), 14"(356mm), 10"(524mm)</p> <p>Media type allowing borderless printing: Heavyweight Coated Paper, Premium Matte Paper, Glossy Photo Paper, Semi-Glossy Photo Paper, Extra Heavyweight Coated Paper, Heavyweight Glossy Photo Paper 2, Heavyweight SemiGlos Photo Paper 2, Satin Photographic Paper 190gsm, Premium Coated Paper, Glossy Photographic Paper 190gsm, Glossy Photographic Paper 240gsm, Satin Photographic Paper 240gsm, HW Glossy Photo Paper, HW Satin Photo Paper, Premium RC Photo Luster</p>
Printable area (Cut sheet)	<p>Internal area, excluding a 3mm top margin, 23mm bottom margin and 3mm left and right margins.</p> <p>*1 Borderless printing does not support cut media as yet.</p> <p>*2 The printable area may vary with each type of paper media used.</p>
Printing recommendation area (Roll media)	Internal area, excluding a 20mm top margin, 5mm bottom margin, and 5mm left and right margins.
Printing recommendation area (Cut sheet)	Internal area, excluding a 20mm top margin, 23mm bottom margin, and 5mm left and right margins.
Margins (Roll media)	<p>Roll media: 3mm for top, bottom and left and right margins</p> <p>Borderless roll media: 0mm for top, bottom and left and right margins</p>
Margins (Cut sheet)	<p>3mm top margin, 23mm bottom margin and 3mm left and right margins</p> <p>* Borderless printing does not support cut media as yet.</p>
Memory	<p>256MB</p> <p>Increase of memory: none</p>
Firmware	<p>Flash ROM (update from USB or Ethernet, IEEE1394)</p> <p>- Printer description language</p> <p>GARO (Graphic Arts language with Raster Operation), HP-GL/2, HP RTL</p>
Emulation	Not available.
Interface	USB2.0, Ethernet, IEEE1394 (option)

Operation panel	LCD (160 X 128 dots), 12 keys, 5 LEDs - Panel language English - Message language English, German, French, Italian, Spanish, Chinese, Korean, Russian and Japanese
Printhead/Ink Tank type	Printhead and separate ink tanks
Printhead	[PF-03] Number nozzles: 2560 nozzles per color
Ink tank	[PFI-102] MBK, BK, C, M, Y Capacity: 130ml per color (Ink tanks supplied with the printer contain 90ml of each color.)
Detection functions (Cover system)	Head cap position sensor: Yes/ Cover open/closed sensor: Yes
Detection functions (Ink passage system)	Ink tank sensor: Yes/Remaining ink level sensor: Yes/ Maintenance cartridge sensor: Yes/Used ink tank full sensor: Yes/Printhead sensor: Yes
Detection functions (Carriage system)	Paper slip sensor: Yes/Carriage position sensor: Yes/Carriage home position sensor: Yes/Carriage cover open/closed sensor: Yes/Carriage temperature sensor: Yes
Detection functions (Paper path system)	Paper sensor: Yes/Leading and trailing paper end sensors: Yes/ Paper width sensor: Yes/Slant sensor: Yes/Paper release lever position sensor: Yes/Roll media bottom sensor: Yes/ Remaining roll media sensor: Yes/Feed roller rotation sensor: Yes
Operating noise	Sound pressure level: 54dB (A) or less, operating; 35dB or less, idle Acoustic power level: 6.8 Bels
Operating environment	Temperature: 15 to 30 degrees centigrade Humidity: 10% to 80% without dew condensation
Print quality guaranteed environment	Temperature: 15 to 30 degrees centigrade Humidity: 10% to 80%RH
Power supply	100-240VAC (50/60Hz)
Power consumption (Maximum)	140W or less
Power consumption	When idle in energy save mode (sleep mode) 100-120V: 5W or less (When IEEE1394 board installed, 10W or less) 220-240V: 6W or less (When IEEE1394 board installed, 11W or less) When switched off (idle): 1W or less
Printer unit dimensions (WxDxH)	1507mm(width) x 871mm(depth) x 1094mm(height) (including the stand)
Weight	Approx. 64kg (including the stand)

1.4 Detailed Specifications

1.4.1 Print Speed and Direction

T-1-2

Media Type		Print Priority	Print Quality	Print-Pass	Printing Direction	Print Resolution (dpi)	Used BK ink
Plain Paper/ Recycled Paper	Plain Paper	Office Document	Standard	1/2	Bi-directional	1200x1200	BK
		Line Document/ Text	Draft	1	Bi-directional	1200x1200	BK
				1	Bi-directional	1200x1200	BK
			Standard	1	Bi-directional	1200x1200	BK
			High	2	Single-directional	1200x1200	BK
		2		Single-directional	1200x1200	BK	
		Image	Draft	1	Bi-directional	1200x1200	BK
			Standard	2	Bi-directional	1200x1200	BK
			High	4	Bi-directional	1200x1200	BK
	Plain Paper (High Quality)	Office Document	Standard	1/2	Bi-directional	1200x1200	BK
		Line Document/ Text	Draft	1	Bi-directional	1200x1200	BK
				1	Bi-directional	1200x1200	BK
			Standard	1	Bi-directional	1200x1200	BK
			High	2	Single-directional	1200x1200	BK
		2		Single-directional	1200x1200	BK	
		Image	Draft	1	Bi-directional	1200x1200	BK
			Standard	2	Bi-directional	1200x1200	BK
			High	4	Bi-directional	1200x1200	BK
	Plain Paper (High Grade)	Office Document	Standard	1/2	Bi-directional	1200x1200	BK
		Line Document/ Text	Draft	1	Bi-directional	1200x1200	BK
				1	Bi-directional	1200x1200	BK
			Standard	1	Bi-directional	1200x1200	BK
			High	2	Single-directional	1200x1200	BK
		2		Single-directional	1200x1200	BK	
Image		Draft	1	Bi-directional	1200x1200	BK	
		Standard	2	Bi-directional	1200x1200	BK	
		High	4	Bi-directional	1200x1200	BK	
All Plain Paper, Conser ve MBK	Office Document	Standard	1/2	Bi-directional	1200x1200	BK	
	Line Document/ Text	Draft	1	Bi-directional	1200x1200	BK	
			1	Bi-directional	1200x1200	BK	
		Standard	1	Bi-directional	1200x1200	BK	
		High	2	Single-directional	1200x1200	BK	
	2		Single-directional	1200x1200	BK		
	Image	Draft	1	Bi-directional	1200x1200	BK	
		Standard	2	Bi-directional	1200x1200	BK	
		High	4	Bi-directional	1200x1200	BK	

Media Type		Print Priority	Print Quality	Print-Pass	Printing Direction	Print Resolution (dpi)	Used BK ink
Plain Paper/ Recycled Paper	Economy Bond Paper	Office Document	Standard	1/2	Bi-directional	1200x1200	MBK
		Line Document/ Text	Draft	1	Bi-directional	1200x1200	MBK
				1	Bi-directional	1200x1200	MBK
			Standard	1	Bi-directional	1200x1200	MBK
			High	2	Single-directional	1200x1200	MBK
				2	Single-directional	1200x1200	MBK
		Image	Draft	1	Bi-directional	1200x1200	MBK
			Standard	2	Bi-directional	1200x1200	MBK
			High	4	Bi-directional	1200x1200	MBK
	Universal Bond Paper	Office Document	Standard	1/2	Bi-directional	1200x1200	MBK
		Line Document/ Text	Draft	1	Bi-directional	1200x1200	MBK
				1	Bi-directional	1200x1200	MBK
			Standard	1	Bi-directional	1200x1200	MBK
			High	2	Single-directional	1200x1200	MBK
				2	Single-directional	1200x1200	MBK
		Image	Draft	1	Bi-directional	1200x1200	MBK
			Standard	2	Bi-directional	1200x1200	MBK
			High	4	Bi-directional	1200x1200	MBK
	Standard Paper 1569B 80g	Office Document	Standard	1/2	Bi-directional	1200x1200	MBK
		Line Document/ Text	Draft	1	Bi-directional	1200x1200	MBK
				1	Bi-directional	1200x1200	MBK
			Standard	1	Bi-directional	1200x1200	MBK
			High	2	Single-directional	1200x1200	MBK
				2	Single-directional	1200x1200	MBK
		Image	Draft	1	Bi-directional	1200x1200	MBK
			Standard	2	Bi-directional	1200x1200	MBK
			High	4	Bi-directional	1200x1200	MBK
Standard Paper 1570B 90g	Office Document	Standard	1/2	Bi-directional	1200x1200	MBK	
	Line Document/ Text	Draft	1	Bi-directional	1200x1200	MBK	
			1	Bi-directional	1200x1200	MBK	
		Standard	1	Bi-directional	1200x1200	MBK	
		High	2	Single-directional	1200x1200	MBK	
			2	Single-directional	1200x1200	MBK	
	Image	Draft	1	Bi-directional	1200x1200	MBK	
		Standard	2	Bi-directional	1200x1200	MBK	
		High	4	Bi-directional	1200x1200	MBK	

Media Type		Print Priority	Print Quality	Print-Pass	Printing Direction	Print Resolution (dpi)	Used BK ink
Coated Paper	Coated Paper	Line Document/ Text	Draft	1	Bi-directional	1200x1200	MBK
				1	Bi-directional	1200x1200	MBK
			Standard	2	Bi-directional	1200x1200	MBK
			High	4	Bi-directional	1200x1200	MBK
		Image	Standard	4	Bi-directional	1200x1200	MBK
				High	8	Bi-directional	2400x1200
	Highest			12	Bi-directional	2400x1200	MBK
	Heavyweight Coated Paper	Line Document/ Text	Draft	1	Bi-directional	1200x1200	MBK
				1	Bi-directional	1200x1200	MBK
			Standard	2	Bi-directional	1200x1200	MBK
			High	4	Bi-directional	1200x1200	MBK
		Image	Standard	4	Bi-directional	1200x1200	MBK
				High	8	Bi-directional	2400x1200
	Highest			12	Bi-directional	2400x1200	MBK
	Extra Heavyweight Coated Paper	Line Document/ Text	Draft	1	Bi-directional	1200x1200	MBK
				1	Bi-directional	1200x1200	MBK
			Standard	2	Bi-directional	1200x1200	MBK
			High	4	Bi-directional	1200x1200	MBK
		Image	Standard	4	Bi-directional	1200x1200	MBK
				High	8	Bi-directional	2400x1200
	Highest			12	Bi-directional	2400x1200	MBK
	Recycled Coated Paper	Line Document/ Text	Draft	1	Bi-directional	1200x1200	MBK
				1	Bi-directional	1200x1200	MBK
			Standard	2	Bi-directional	1200x1200	MBK
			High	4	Bi-directional	1200x1200	MBK
		Image	Standard	4	Bi-directional	1200x1200	MBK
				High	8	Bi-directional	2400x1200
	Highest			12	Bi-directional	2400x1200	MBK
	Premium Matte Paper	Line Document/ Text	Draft	1	Bi-directional	1200x1200	MBK
				1	Bi-directional	1200x1200	MBK
			Standard	2	Bi-directional	1200x1200	MBK
			High	4	Bi-directional	1200x1200	MBK
		Image	Standard	4	Bi-directional	1200x1200	MBK
				High	8	Bi-directional	2400x1200
	Highest			16	Bi-directional	2400x1200	MBK
	Colored Coated Paper	Image	Standard	4	Bi-directional	1200x1200	BK
High			8	Bi-directional	1200x1200	BK	

Media Type		Print Priority	Print Quality	Print-Pass	Printing Direction	Print Resolution (dpi)	Used BK ink	
Coated Paper	Premium Coated Paper	Line Document/ Text	Draft	1	Bi-directional	1200x1200	BK	
				1	Bi-directional	1200x1200	BK	
			Standard	2	Bi-directional	1200x1200	BK	
			High	4	Bi-directional	1200x1200	BK	
		Image	4	Bi-directional	1200x1200	BK		
			Standard	4	Bi-directional	1200x1200	BK	
	High		8	Bi-directional	2400x1200	BK		
	LightWeight Coated Paper J80270 90g	Line Document/ Text	Draft	1	Bi-directional	1200x1200	BK	
				1	Bi-directional	1200x1200	BK	
			Standard	2	Bi-directional	1200x1200	BK	
			High	4	Bi-directional	1200x1200	BK	
		Image	4	Bi-directional	1200x1200	BK		
			Standard	4	Bi-directional	1200x1200	BK	
	High		8	Bi-directional	2400x1200	BK		
	High Resolution Barrier Paper 180g	Line Document/ Text	Draft	1	Bi-directional	1200x1200	BK	
				1	Bi-directional	1200x1200	BK	
			Standard	2	Bi-directional	1200x1200	BK	
			High	4	Bi-directional	1200x1200	BK	
		Image	4	Bi-directional	1200x1200	BK		
			Standard	4	Bi-directional	1200x1200	BK	
	High		8	Bi-directional	2400x1200	BK		
	Matt Coated Paper 9171 120g	Line Document/ Text	Draft	1	Bi-directional	1200x1200	BK	
				1	Bi-directional	1200x1200	BK	
			Standard	2	Bi-directional	1200x1200	BK	
High			4	Bi-directional	1200x1200	BK		
Image		4	Bi-directional	1200x1200	BK			
		Standard	4	Bi-directional	1200x1200	BK		
	High	8	Bi-directional	2400x1200	BK			
Extra Matt Coated Paper 7215 180g	Line Document/ Text	Draft	1	Bi-directional	1200x1200	BK		
			1	Bi-directional	1200x1200	BK		
		Standard	2	Bi-directional	1200x1200	BK		
		High	4	Bi-directional	1200x1200	BK		
	Image	4	Bi-directional	1200x1200	BK			
		Standard	4	Bi-directional	1200x1200	BK		
High		8	Bi-directional	2400x1200	BK			
				Highest	12	Bi-directional	2400x1200	BK

Media Type		Print Priority	Print Quality	Print-Pass	Printing Direction	Print Resolution (dpi)	Used BK ink
Coated Paper	Opaque Paper White 120g	Line Document/ Text	Draft	1	Bi-directional	1200x1200	BK
				1	Bi-directional	1200x1200	BK
			Standard	2	Bi-directional	1200x1200	BK
			High	4	Bi-directional	1200x1200	BK
		Image	Standard	4	Bi-directional	1200x1200	BK
				8	Bi-directional	2400x1200	BK
				12	Bi-directional	2400x1200	BK
			High	8	Bi-directional	2400x1200	BK
				12	Bi-directional	2400x1200	BK
	Matt Coated Paper 140g	Line Document/ Text	Draft	1	Bi-directional	1200x1200	BK
				1	Bi-directional	1200x1200	BK
			Standard	2	Bi-directional	1200x1200	BK
			High	4	Bi-directional	1200x1200	BK
		Image	Standard	4	Bi-directional	1200x1200	BK
				8	Bi-directional	2400x1200	BK
				12	Bi-directional	2400x1200	BK
			High	8	Bi-directional	2400x1200	BK
				12	Bi-directional	2400x1200	BK
	Photo Realistic Paper 210g	Line Document/ Text	Draft	1	Bi-directional	1200x1200	BK
				1	Bi-directional	1200x1200	BK
			Standard	2	Bi-directional	1200x1200	BK
			High	4	Bi-directional	1200x1200	BK
		Image	Standard	4	Bi-directional	1200x1200	BK
				8	Bi-directional	2400x1200	BK
12				Bi-directional	2400x1200	BK	
High			8	Bi-directional	2400x1200	BK	
			12	Bi-directional	2400x1200	BK	
LightWeight Coated Paper	Line Document/ Text	Draft	1	Bi-directional	1200x1200	BK	
			1	Bi-directional	1200x1200	BK	
		Standard	2	Bi-directional	1200x1200	BK	
		High	4	Bi-directional	1200x1200	BK	
	Image	Standard	4	Bi-directional	1200x1200	BK	
			8	Bi-directional	2400x1200	BK	
			12	Bi-directional	2400x1200	BK	
		High	8	Bi-directional	2400x1200	BK	
			12	Bi-directional	2400x1200	BK	
Photo Paper	Glossy Photo Paper	Image	Standard	6	Bi-directional	1200x1200	MBK
			High	8	Bi-directional	2400x1200	MBK
			Highest	16	Bi-directional	2400x1200	MBK
	Semi-Glossy Photo Paper	Image	Standard	6	Bi-directional	1200x1200	MBK
			High	8	Bi-directional	2400x1200	MBK
			Highest	16	Bi-directional	2400x1200	MBK
	Heavyweight Glossy Photo Paper 2	Image	Standard	6	Bi-directional	1200x1200	MBK
			High	8	Bi-directional	2400x1200	MBK
			Highest	16	Bi-directional	2400x1200	MBK
	Heavywght SemiGlos Photo Paper 2	Image	Standard	6	Bi-directional	1200x1200	MBK
			High	8	Bi-directional	2400x1200	MBK
			Highest	16	Bi-directional	2400x1200	MBK

Media Type		Print Priority	Print Quality	Print-Pass	Printing Direction	Print Resolution (dpi)	Used BK Ink
Photo Paper	Satin Photographic Paper 190gsm	Image	Standard	6	Bi-directional	1200x1200	MBK
			High	8	Bi-directional	2400x1200	MBK
			Highest	16	Bi-directional	2400x1200	MBK
	Premium RC Photo Luster , 10 mil	Image	Standard	6	Bi-directional	1200x1200	BK
			High	8	Bi-directional	2400x1200	BK
			Highest	16	Bi-directional	2400x1200	BK
	Instant Dry Papers Glossy 200g	Image	Standard	6	Bi-directional	1200x1200	BK
			High	8	Bi-directional	2400x1200	BK
			Highest	16	Bi-directional	2400x1200	BK
	Instant Dry Papers Satin 200g	Image	Standard	6	Bi-directional	1200x1200	BK
			High	8	Bi-directional	2400x1200	BK
			Highest	16	Bi-directional	2400x1200	BK
	Photo Paper High Glossy 250g	Image	Standard	6	Bi-directional	1200x1200	BK
			High	8	Bi-directional	2400x1200	BK
			Highest	16	Bi-directional	2400x1200	BK
	Photo Paper Semi Matt 250g	Image	Standard	6	Bi-directional	1200x1200	BK
			High	8	Bi-directional	2400x1200	BK
			Highest	16	Bi-directional	2400x1200	BK
Photo Paper Satin 240g	Image	Standard	6	Bi-directional	1200x1200	BK	
		High	8	Bi-directional	2400x1200	BK	
		Highest	16	Bi-directional	2400x1200	BK	
Photo Paper Pearl 260g	Image	Standard	6	Bi-directional	1200x1200	BK	
		High	8	Bi-directional	2400x1200	BK	
		Highest	16	Bi-directional	2400x1200	BK	
Proofing Paper	Proofing Paper	Image	Standard	6	Bi-directional	1200x1200	MBK
			High	8	Bi-directional	2400x1200	MBK
			Highest	16	Bi-directional	2400x1200	MBK
	Professional Proof and Photo Glossy 195g	Image	Standard	6	Bi-directional	1200x1200	BK
			High	8	Bi-directional	2400x1200	BK
			Highest	16	Bi-directional	2400x1200	BK
	Professional Proof and Photo Semiglossy 195g	Image	Standard	6	Bi-directional	1200x1200	BK
			High	8	Bi-directional	2400x1200	BK
			Highest	16	Bi-directional	2400x1200	BK
	Professional Proof and Photo Semigloss 255g	Image	Standard	6	Bi-directional	1200x1200	BK
			High	8	Bi-directional	2400x1200	BK
			Highest	16	Bi-directional	2400x1200	BK
Synthetic Paper	Synthetic Paper	Image	Standard	6	Bi-directional	1200x1200	MBK
			High	8	Bi-directional	2400x1200	MBK
			Highest	16	Bi-directional	2400x1200	MBK
	Adhesive Synthetic Paper	Image	Standard	6	Bi-directional	1200x1200	MBK
			High	8	Bi-directional	2400x1200	MBK
			Highest	16	Bi-directional	2400x1200	MBK

Media Type		Print Priority	Print Quality	Print-Pass	Printing Direction	Print Resolution (dpi)	Used BK ink
Adhesive Matt Paper	High Resolution Graphic Paper Self ADH	Image	Standard	6	Bi-directional	1200x1200	BK
			High	8	Bi-directional	2400x1200	BK
			Highest	16	Bi-directional	2400x1200	BK
CAD	CAD Tracing Paper	Line Document/ Text	Draft	1	Bi-directional	1200x1200	BK
				1	Bi-directional	1200x1200	BK
			Standard	2	Bi-directional	1200x1200	BK
			High	4	Bi-directional	1200x1200	BK
				4	Bi-directional	1200x1200	BK
	CAD Translucent Matte Film	Line Document/ Text	Draft	1	Bi-directional	1200x1200	BK
				1	Bi-directional	1200x1200	BK
			Standard	2	Bi-directional	1200x1200	BK
			High	4	Bi-directional	1200x1200	BK
				4	Bi-directional	1200x1200	BK
	CAD Translucent Matte Film	Line Document/ Text	Standard	2	Bi-directional	1200x1200	MBK
				4	Bi-directional	1200x1200	MBK
			Highest	4	Bi-directional	1200x1200	MBK
				8	Bi-directional	1200x1200	MBK
				8	Bi-directional	1200x1200	MBK
Special	Special 1	Image	Standard	6	Bi-directional	1200x1200	MBK
			High	8	Bi-directional	2400x1200	MBK
			Highest	16	Bi-directional	2400x1200	MBK
	Special 2	Image	Standard	6	Bi-directional	1200x1200	MBK
			High	8	Bi-directional	2400x1200	MBK
			Highest	16	Bi-directional	2400x1200	MBK
	Special 3	Image	Standard	6	Bi-directional	1200x1200	MBK
			High	8	Bi-directional	2400x1200	MBK
			Highest	16	Bi-directional	2400x1200	MBK
	Special 4	Image	Standard	6	Bi-directional	1200x1200	MBK
			High	8	Bi-directional	2400x1200	MBK
			Highest	16	Bi-directional	2400x1200	MBK
	Special 5	Image	Standard	6	Bi-directional	1200x1200	MBK
			High	8	Bi-directional	2400x1200	MBK
			Highest	16	Bi-directional	2400x1200	MBK

1.4.2 Interface specifications

a. [USB] (Standard)

(1) Interface Type

USB 2.0, full speed (12 Mbits/sec), high Speed (480 Mbits/sec)

(2) Methods of data transfer

Controlled transfer

Bulk transfer

(3) Signal level

Compliant with the USB standard.

(4) Interface cable

Twisted-pair shielded cable, 5.0 m or shorter

Compliant with the USB standard.

Wire AWG No.28, data line pair (AWG: American Wire Gauge)

AWG No.20 to No.28, distribution line pair

(5) Interface connector

Printer side: USB standard, Series B receptacle

Cable side: USB standard, Series B plug

b. [Network] (Standard)

(1) Interface Type

IEEE802.3-compliant interface

(2) Data transfer method

10Base-T/100Base-TX

(3) Signal level

Input: Threshold.

10Base-T: Max +585mV, min +300mV

100Base-TX: Turn-on +1000mV diff pk-pk, turn-off +200mV diff pk-pk

Output:

10Base-T: +2.2V - + 2.8V

100Base-TX: +0.95V - +1.05V

(4) Interface cable

Category 5 (UTP or FTP) cable, 100 m or shorter

Compliant with the ANSI/EIA/TIA-568A or ANSI/EIA/TIA-568B standard.

(5) Interface connector

Printer side: IEEE802.3 and ANSI X3.263-compliant, ISO/IEC60603-7 standard

c. [IEEE1394] (option)

(1) Interface Type

IEEE1394-1995, P1394a (Version 2.0)-compliant interface

(2) Method of data transfer

Asynchronous transfer

(3) Signal levels

Input:

Differential input voltage: +173mV - +260mV during S100 arbitration

+142mV - +260mV, receiving data

+171mV - +262mV during S200 arbitration

+132mV - +260mV, receiving data

+168mV - +265mV during S400 arbitration

+118mV - +260mV, receiving data

Output :
Differential output voltage: +172mV - +265mV

(4) Interface cable
Twisted-pair shielded cable, 4.5 mm or shorter.
Compliant with the IEEE1394-1995 or (Version 2.0) standard

(5) Interface connector
Printer side: IEEE1394-compliant, 6-pin connector (socket)
Cable side: IEEE1394-compliant, 6-pin connector (plug)
Cable side: Compliant with the ANSI/EIA/TIA-568A or ANSI/EIA/TIA-568B standard, Type RJ-45.

1.5 Names and Functions of Components

1.5.1 Front

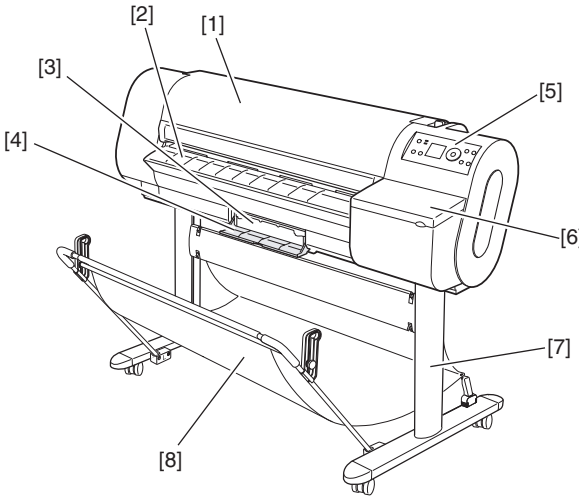

F-1-12

[1] Top cover
Open this cover when installing the printhead, load media and clear jams inside the printer.

[2] Eject guide
Supports ejected media to keep it from floating up.

[3] Maintenance cartridge
Blots excess inks.

[4] Maintenance cartridge cover
Open this cover to replace the maintenance cartridge.

[5] Operation panel
Operate the printer or check its status from this panel.

[6] Ink tank cover
Open this cover to replace ink tanks.

[7] Stand (option)
It is a stand that puts the printer.

[8] Output stacker (included with stand)
It is a stacker made of the cloth that stacks the ejected media.

1.5.2 Rear

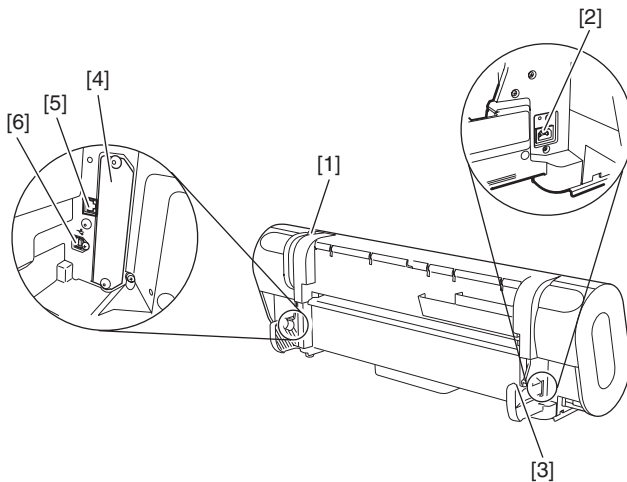

F-1-13

[1] Release lever

Releases the paper retainer. Press this lever rearward to load paper or clean the interiors of the printer.

[2] Power connector

Connect the power cord to this connector.

[3] Roller holder slot

Set the roll holder in this guide slot.

[4] Expansion PCB slot

Mount an IEEE1394 (Fire Wire) expansion PCB on this slot.

[5] USB port

Connect the USB cable to this port. Ready for the USB2.0 hi-speed mode.

[6] Ethernet connector

Connect the Ethernet cable to this connector.

1.5.3 Carriage

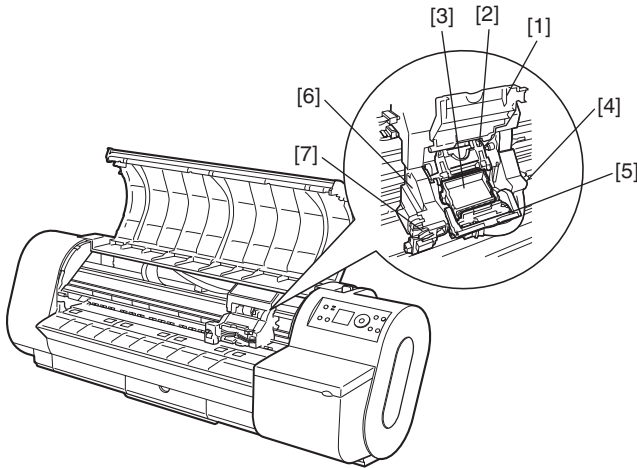

F-1-14

[1] Carriage cover

Protects the carriage.

[2] Printhead fixer cover

Clamps the printhead.

[3] Printhead

A key component that houses nozzles.

[4] Shaft cleaner

Keeps the carriage shaft clean.

[5] Printhead fixer lever

Locks the printhead fixer cover.

[6] Slant adjustment lever

Fine-adjusts slants in ruled lines during printing.

[7] Cutter unit

A curved cutting edge that cuts paper automatically. It is tucked inside when cutting is not performed.

1.6 Basic Operation

1.6.1 Operation Panel

The functions of the keys and meanings of LED indications on the operation panel are described below.

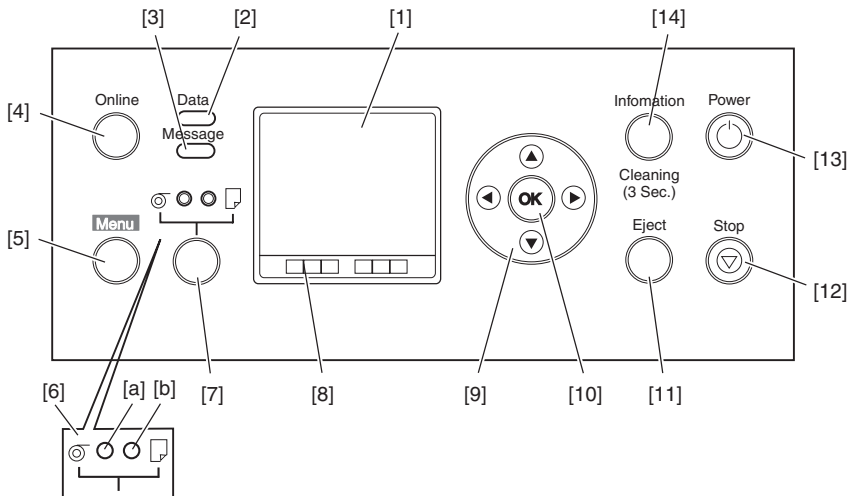

F-1-15

[1] Display

Displays the printer menu, status or messages.

[2] Data lamp (green)

"Blinking" The printer is receiving or processing a print job when it is printing.

The printer has suspended a print job or is receiving firmware data when it is not printing.

"Off" No print job is available.

[3] Message lamp (orange)

"Lit continuously" A warning message is on display.

"Blinking" An error message is on display.

"Off" The printer is normal or is powered off.

[4] Online key

Switches the printer between two alternative modes: online and offline.

"Lit continuously" The printer is in online mode. Lights green.

"Off" The printer is in offline mode.

[5] Menu key

Displays a printer main menu.

[6] Paper source selector

[a] Roll media lamp (green)

"Lit continuously" Roll media have been selected as a paper source.

"Off" Cut media have been selected as a paper source.

[b] Cut media lamp (green)

"Lit continuously" Cut media have been selected as a paper source.

"Off" Roll media have been selected as a paper source.

[7] Paper source selector key

Toggles a paper source between roll and cut media each time the key is pressed.

[8] Color labels

Colors and names of ink tanks associated with the remaining ink levels appearing on the display.

[9] ▲ ▼ ◀ ▶ Keys

[Menu mode]

"▲ key" Displays the previous action or setting.

"▼ key" Displays the next action or setting.

"◀ key" Opens the menu one level above.

"▶ key" Opens the menu one level lower.

[Offline mode]

"▲ key" Feeds roll media manually in the direction opposite to the direction in which paper is ejected.

"▼ key" Feeds roll media manually.

[10] OK key

Sets or runs a selected action or value when the printer is in menu mode.

[11] eject key

Executing menu and ejects paper.

[12] Stop key

Quits a processing job.

[13] Power key

Switches the power to the printer on and off.

[14] Information key

Displays a printer submenu. Information about the inks and paper displays each time this key is pressed.

Hold this key for 3 seconds to clean the printhead.

1.6.2 Main Menu

The printer has a Main menu which includes a menu related to maintenance such as adjustment of ink ejection position of each nozzle and head cleaning, a menu related to printing settings such as auto cutting and ink drying time, and a menu related to parameters such as a message language.

1. Main menu operations

a) How to enter the Main menu

To enter the Main menu, press the [Menu] button on the operation panel.

b) How to exit the Main menu

To exit the Main menu, press the [Online] button.

c) Buttons used with the Main menu

- Selecting menus and parameters: [◀] or [▶] button

- Going to the next lower-level menu: [▼] button

- Going to the next higher-level menu: [▲] button

- Determining a selected menu or parameter: [OK] button

2. Main Menu

The structure of the main menu is as follows. Values at right indicated by an asterisk "*" are the defaults.

T-1-3

First Level	Second Level	Third Level	Fourth Level	Fifth Level
[Media Menu]	[Roll Media Type>(*1)	[HW Glossy Photo>(*5)		
		[HW SemiGl Photo>(*5)		
		[Syn. Paper>(*5)		
		[Adh. Syn. Paper>(*5)		
		[Proofing Paper>(*5)		
		[News Proof 1>(*5)		
		[News Proof 2>(*5)		
		[News Proof 3>(*5)		
		[Colored Coated>(*5)		

First Level	Second Level	Third Level	Fourth Level	Fifth Level
		[CAD Trace Paper>(*5)		
		[CAD Matte Film>(*5)		
		[CAD Clear Film>(*5)		
		Special # Here, the number is 1 to 5(*5)		
	[Chk Remain.Roll]	[Off]*		
		[On]		
	[Roll Length Set)(*2)	[### m]		
		[### feet>(*9)		
[Paper Details]	(The paper type is displayed here.) (*5)	[Roll DryingTime]	[Off]	
			[30 sec.]	
			[1 min.]	
			[3 min.]	
			[5 min.]	
			[10 min.]	
			[30 min.]	
			[60 min.]	
		[Scan Wait Time]	[Off]	
			[1 sec.]	
			[3 sec.]	
			[5 sec.]	
			[7 sec.]	
			[9 sec.]	
		[Feed Priority]	[Automatic]*	
			[Band Joint]	
			[Print Length]	
		[Adjust Length]	-0.70 to 0.70	
		[Head Height]	[Automatic]*	
			[Highest]	
			[High]	
			[Standard]	
			[Low]	
			[Lowest]	

T-1-4

First Level	Second Level	Third Level	Fourth Level	Fifth Level
[Paper Details]	(The paper type is displayed here.) (*5)	[Skew Check Lv.]	[Standard]*	
			[Loose]	
			[Off]	
		[VacuumStrngth]	[Automatic]	
			[Strongest]	

First Level	Second Level	Third Level	Fourth Level	Fifth Level
			[Strong]	
			[Standard]	
			[Weakest]	
		[Width Detection]	[Off]	
			[On]*	
		[NearEnd RollMrgn]	[3mm]	
			[20mm]	
		[Cut Speed]	[Fast]	
			[Standard]	
			[Slow]	
		[Trim Edge First]	[Automatic]	
			[Off]	
			[On]	
		[Cutting Mode]	[Automatic]	
			[Eject]	
			[Manual]	
		[Bordless Margin]	[Automatic]	
			[Fixed]	
		[CutDustReduct.]	[Off]	
			[On]	
[NearEnd Sht Mrgn]	[3mm]			
	[20mm]			
[Return Defaults]	[No]			
	[Yes]			
[GL2 Settings]	[GL2 Replot]	[No]		
		[Yes]		
	[GL2 BufferClear]	[No]		
		[Yes]		
	[Color Mode]	[Color]*		
		[Monochrome]		
	[Print Quality]	[Draft]		
		[Standard]*		
		[High]		
	[Input Resolution]	[600dpi]*		
		[300dpi]		
	[Media Source]	[Roll Paper]*		
		[Cassette]		
		[Manual]		
	[Conserve Paper]	[Off]		
		[On]*		

T-1-5

First Level	Second Level	Third Level	Fourth Level	Fifth Level
[GL2 Settings]	[End Point Shape]	[Software]*		
		[Rounded]		
	[Smoothing]	[Software]*		
		[Smooth]		
	[Line Width]	[1dot]		
		[2dot]		
		[3dot]		
		[4dot]*		
		[5dot]		
		[6dot]		
[7dot]				
[Adjust Printer]	[Auto Head Adj.]	[Standard Adj.]	[No]	
			[Yes]	
		[Advanced Adj.]	[No]	
			[Yes]	
		[Auto Print]	[Off]	
			[On]*	
	[Manual Head Adj]	[No]		
		[Yes]		
	[Auto Band Adj.]	[Standard Adj.]	[No]	
			[Yes]	
		[Advanced Adj.]	[No]	
		[Yes]		
	[Manual Band Adj]	[No]		
		[Yes]		
[Adjust Length](*3)	[No]			
	[Yes]			
[Adjust Head Skew]	[No]			
	[Yes]			
[Interface Setup]	[EOP Timer]	[10 sec.]		
		[30 sec.]		
		[1 min.]		
		[2 min.]		
		[5 min.]		
		[10 min.]*		
		[30 min.]		
		[60 min.]		
	[TCP/IP]	[IP Mode]	[Automatic]	
			[Manual]*	
		[Protocol](*4)	[DHCP]	
			[On]	

First Level	Second Level	Third Level	Fourth Level	Fifth Level
				[Off]*
			[BOOTP]	[On]
				[Off]*
			[RARP]	[On]
				[Off]*

T-1-6

First Level	Second Level	Third Level	Fourth Level	Fifth Level	
[Interface Setup]	[TCP/IP]	[IP Setting]	[IP Address]	0.0.0.0* to 255.255.255.255	
			[Subnet Mask]	0.0.0.0* to 255.255.255.255	
			[Default G/W]	0.0.0.0* to 255.255.255.255	
	[NetWare]	[NetWare]	[NetWare]	[On]	
				[Off]*	
			[Frame Type](*6)	[Auto Detect]	
				[Ethernet 2]	
				[Ethernet 802.2]*	
				[Ethernet 802.3]	
				[Ethernet SNAP]	
			[Print Service](*6)	[BinderyPServer]	
				[RPrinter]	
				[NDSPServer]*	
				[NPrinter]	
	[AppleTalk]	[On]			
		[Off]*			
	[Ethernet Driver]	[Ethernet Driver]	[Auto Detect]	[On]*	
				[Off]	
			[Comm.Mode](*7)	[Half Duplex]*	
				[Full Duplex]	
			[Ethernet Type](*7)	[10 Base-T]*	
				[100 Base-TX]	
			[Spanning Tree]	[Not Use]*	
				[Use]	
				[MAC Address]	
			[Ext.Interface]	[No]	
	[IEEE1394]				
	[Init. Settings]	[No]			
		[Yes]			
[Maintenance]	[Maint. cart.]	[No]			
		[Yes]			

First Level	Second Level	Third Level	Fourth Level	Fifth Level
	[Replace P.head]	[No]		
		[Yes]		
	[Repl. S. Cleaner]	[No]		
		[Yes]		
	[Change Cutter]	[No]*		
		[Yes]		
	[Move Printer]	[No]		
		[Yes]		
[System Setup]	Warning]	[Buzzer]	[Off]	
			[On]*	
		[Detect Mismatch]	[Pause]	
			[Warning]*	
			[None]	

T-1-7

First Level	Second Level	Third Level	Fourth Level	Fifth Level	
[System Setup]	[Keep Media Size]	[Off]*			
		[On]			
	[Paper Size Basis]	[Sht Selection 1]			[ISO A3+]*
					[13"x19"(Super B)]
		[Sht Selection 2]			[ISO B1]*
					[28"x40"(ANSI F)]
	[Noz. Check Freq.]	[Off]			
		[1 page]			
		[10 pages]			
		[Automatic]*			
		[Sleep Timer]			[5 min.]*
		[10 min.]			
		[15 min.]			
		[20 min.]			
		[30 min.]			
		[40 min.]			
		[50 min.]			
		[60 min.]			
		[240 min.]			
	[Length Unit]	[meter]*			
[feet/inch]					
[Time Zone]	[0: London (GMT)]				
	[+1: Paris, Rome]				
	[+2: Athens, Cairo]				
	[+3: Moscow]				

First Level	Second Level	Third Level	Fourth Level	Fifth Level
		[+4: Eerenan, Baku]		
		[+5: Islamabad]		
		[+6: Dacca]		
		[+7: Bangkok]		
		[+8: Hong Kong]		
		[+9: Tokyo, Seoul]		
		[+10: Canberra]		
		[+11: NewCaledonia]		
		[+12: Wellington]		
		[-12: Eniwetok]		
		[-11: Midway is]		
		[-10: Hawaii (AHST)]		
		[-9: Alaska (AKST)]		
		[-8: Oregon (PST)]		
		[-7: Arizona (MST)]		
		[-6: Texas (CST)]		
		[-5: NewYork (EST)]		

T-1-8

First Level	Second Level	Third Level	Fourth Level	Fifth Level
[System Setup]	[Time Zone]	[-4: Santiago]		
		[-3: Buenos Aires]		
		[-2:]		
		[-1: Cape Verde]		
	[Date Format]	[yyyy/mm/dd]*		
		[dd/mm/yyyy]		
		[mm/dd/yyyy]		
	[Date & Time]	[Date]		[yyyy/mm/dd](*8)
		[Time]		[hh:mm]
	[Language]	[Japanese]*		
		[Francais]		
		[Italiano]		
		[Deutsch]		
		[Espanol]		
		[Pyccknn]		
		[Chinese]		
		[Korea]		
[Engulish]				
[Contrast Adj.]	-4 to 4			
[Reset PaprSetngs]	[No]			
	[Yes]			

First Level	Second Level	Third Level	Fourth Level	Fifth Level		
[Test Print]	[Status Print]	[No]				
		[Yes]				
	[Media Details]	[No]				
		[Yes]				
	[Print Job Log]	[No]				
		[Yes]				
	[Menu Map]	[No]				
		[Yes]				
	[Nozzle Check]	[No]				
		[Yes]				
	[Information]]	[System Info]				
		[Error Log]			[##### #####]	
		[Job Log]			(Choose from information about the latest three print jobs.)	[Document Name]
						[User Name]
[Page Count]						
[Job Status]						
[Print Start Time]			[yyyy/mm/dd hh:mm]			
[Print End Time]			[yyyy/mm/dd hh:mm]			
[Print Time]			[xxx sec.]			
[Print Size]			[xxxxxxxxsq.mm]			
[Media Type]						
[Interface]						
[Ink Consumed]	[xx.x ml]					

*1: Displayed if a roll is loaded.

*2: Displayed if Chk Remain.Roll is On.

*3: Displayed if IP Mode is Automatic.

*4: Displayed if IP Mode is Automatic.

*5: For information on the types of paper the printer supports, refer to the Media Guide. The media type setting in the printer driver and related software (as well as on the Control Panel) is updated when you install Media Configuration Tool from the User Software CD-ROM or if you change paper information by using Media Configuration Tool.

*6: Available only if NetWare is On.

*7: Available only if Auto Detect is Off.

*8: Follows the setting in Date Format.

*9: Not displayed if a roll or a sheet has been fed.

3. Main menu during printing

The structure of the main menu during printing is as follows.

First Level	Second Level	Third Level	Fourth Level	Fifth Level
[Menu Durng Prtng]	[Head Cleaning]	[Head Cleaning A]		
		[Head Cleaning B]		
	[Fine Band Adj.]	-5 to 5		
	[Information]	[System Info]		
		[Error Log]		
	[Job Log]	(Choose from information about the latest three print jobs.)	[Document Name]	
			[User Name]	
			[Page Count]	
			[Job Status]	
			[Print Start Time]	
			[Print End Time]	
			[Print Time]	
			[Print Size]	
		[Media Type]		
		[Interface]		
		[Ink Consumed]		

4. Main Menu Settings

Main menu items are described in the following tables.

T-1-10

Setting Item	Description, Instructions
[Paper Cut]	Displayed if a roll is loaded. Choose Yes to cut the roll at the current position. The paper will be fed, if necessary, so that the sheet is at least 10 cm (39.4 in.) long after the cut. The paper will not be cut if there is not enough paper left to feed the paper this much.
[Rep. Ink Tank]	When exchanging the ink tank, choose Yes and follow the instructions on the screen.
[Head Cleaning]	Specify Printhead cleaning options. Choose Head Cleaning A if printing is faint, oddly colored, or contains foreign substances. Choose Head Cleaning B if no ink is printed at all, or if printing is not improved by Head Cleaning A .
[Media Menu]	Specify the type and size of paper.
[Paper Details]	Specify detailed paper-related settings, including the ink drying time and borderless printing options.
[GL2 Settings]	Make settings for making prints using GL2.
[Adjust Printer]	Adjust the Printhead alignment or amount of feed by printing a test pattern.
[Interface Setup]	Configure the network settings.
[Maintenance]	Replace the Printhead , prepare to transfer the printer, and clean the Pick Up Roller .
[System Setup]	Specify the printer system settings, including the date format and display language.
[Test Print]	Choose Status Print to print information about the printer. Choose Media Details to print the paper settings as specified in Med.Detail Set. . Choose Print Job Log to print a record of print jobs, including the paper type and size, amount of ink used, and so on. Choose Menu Map to print a list of the main menu options. Choose Nozzle Check to print a test pattern for checking the nozzles. If you have selected a leading edge margin of 20 mm in Nr End Sht Mrgn in the printer menu, the test print sheet may not be printed completely.
[Information]	Displays the information about the printer and history of print jobs.

[Paper Settings]

T-1-11

Setting Item	Description, Instructions
[Cas Paper Type]	Choose the type of paper in the Cassette .
[Roll Media Type]	Choose the type of roll.
[Chk Remain.Roll]	Choose On to print a barcode at the end of a roll before you remove it. The printed barcode can be used in managing the amount of roll paper left. Choose Off if you prefer not to print the barcode.
[Roll Length Set]	Displayed if Chk Remain.Roll is On . If a barcode is not printed on rolls, specify the roll length. The roll length is displayed in meters (1.0 - 91.0 m) or feet (1 - 300 ft.), depending on the setting in Length Unit .

[Paper Details]

T-1-12

Setting Item	Description, Instructions	
(The paper type is displayed here.)	[Roll DryingTime]	Specify the time to wait for the ink to dry for each sheet.
	[Scan Wait Time]	Specify the time to wait for the ink to dry between each scan in bidirectional printing, in consideration of how quickly the paper absorbs ink. Note that printing will take longer if you specify a wait time.
	[Feed Priority]	Specify exact paper feeding, if desired. Normally, select Automatic . Choose Print Length if you prefer to feed the paper an exact amount. However, note that choosing Print Length may result in slight banding in the direction of Carriage scanning.
	[Adjust Length]	Displayed if Feed Priority is Print Length . Adjustment relative to the amount of stretching or shrinkage of the current paper. For paper that tends to stretch, increase the feed amount by setting the adjustment value toward +. For paper that tends to shrink, decrease the feed amount by setting the adjustment value toward -. The setting for the amount of paper stretching or shrinkage is relative. If you access it again later, it will be displayed as 0.00 %.
	[Head Height]	Adjust the Printhead height.
	[Skew Check Lv.]	If you print on Japanese Paper Washi or other handmade paper that has an irregular width, choose Loose for a higher skew detection threshold, or choose Off to disable skew detection. However, if paper is loaded askew when detection is Off, note that paper jams or Platen soiling may occur. If strict skew detection is required, choose High Accuracy.
	[VacuumStrngth]	Specify the level of suction that holds paper against the Platen .
	[Width Detection]	Make this setting when the print size is different from the media size, for example, when you want to make a print within a frame. When you select [OFF], the paper width is not detected.

Setting Item	Description, Instructions
[NearEnd RollMrgn]	Specify a margin at the leading edge of roll paper to ensure better printing quality at the leading edge. Note that if you choose 3 mm , it may lower the printing quality at the leading edge and affect feeding accuracy. The printed surface may be scratched, and ink may adhere to the the leading edge.
[Cut Speed]	Choose the cutting speed. For media such as film that are more likely to generate debris when cut, choose Fast to reduce the amount of debris.
[Trim Edge First]	The leading edge of roll media is cut when it is loaded.
[Cutting Mode]	Specify if the Cutter Unit is used for cutting. Choose Automatic to have roll paper cut automatically after printing. If you choose Eject , the paper will not be cut after printing. Instead, a line will be printed at the cut position.
[Bordless Margin]	Adjust the margin during borderless printing.
[CutDustReduct.]	Choose On to reduce the amount of debris generated when cutting film and similar media by printing a line at the cut position. This option reduces the amount of debris given off after cutting.
[Manual Feed]	Choose how the paper is supplied, Top for printing from the Tray or Front for printing from the Front Paper Feed Slot .
[NearEnd Sht Mrgn]	Specify a margin at the leading edge of sheets to ensure better printing quality at the leading edge. Note that if you choose 3 mm , it may lower the printing quality at the leading edge and affect feeding accuracy. The printed surface may be scratched, and ink may adhere to the the leading edge. If you have selected 20 mm , the test print sheet may not be printed completely.
[Return Defaults]	Choose Yes to restore Med.Detail Set. to the factory default values.

[GL2 Settings]

T-1-13

Setting Item	Description, Instructions
[GL2 Replot]	Reprint the last printed page stored in the printer.
[GL2 BufferClear]	Delete the last printed page stored in the printer.
[Color Mode]	Choose the color mode.
[Print Quality]	Choose the print quality.
[Input Resolution]	Select [600dpi] or [300dpi] as the print resolution.
[Media Source]	Select the method of feeding paper when using the HP-GL/2 for printing.
[Conserve Paper]	Print using paper sparingly.
[End Point Shape]	Select [Software] or [Round] as the shape of the line end.
[Smoothing]	Select whether to print an arc with a smooth curve or polygon.
[Line Width]	Select the printing line width for the data for which a line width is not specified.

[Adjust Printer]

T-1-14

Setting Item		Description, Instructions
[Auto Head Adj.]	[Standard Adj.]	Choose Yes to have the printer print and read a test pattern for the automatic adjustment of Printhead alignment relative to the printing direction.
	[Advanced Adj.]	Choose Yes to have the printer print and read a test pattern for the automatic adjustment of Printhead alignment relative to the nozzle, ink tank, and printing direction. Three sheets are required when printing on sheets.
	[Auto Print]	Choose On to have the printer automatically execute the Advanced Adj. operations after you replace the Printhead .
[Manual Head Adj]		Choose Yes to print a test pattern for adjustment of Printhead alignment relative to the printing direction. Enter the adjustment value manually based on the resulting pattern.
[Auto Band Adj.]	[Standard Adj.]	Choose Yes to have the printer print and read a test pattern for band adjustment, based on which the printer automatically adjusts the feed amount.
	[Advanced Adj.]	Choose this option when using paper other than genuine Canon paper, or paper for purposes other than checking output. Choose Yes to have the printer print and read a test pattern for band adjustment, based on which the printer automatically adjusts the feed amount. Note that this function takes more time and requires more ink than Standard Adj. Two sheets are required when printing on sheets.
[Manual Band Adj]		Choose Yes to print a test pattern for adjusting the feed amount based on the paper type. Two sheets are required when printing on sheets.
[Adjust Length]		Choose Yes to print a test pattern for adjustment relative to paper stretching or shrinkage, after which you can enter the amount of adjustment.
[Adjust Head Skew]		Selecting [Yes] will print the pattern for adjusting the print head inclination.

[Interface Setup]

T-1-15

Setting Item		Description, Instructions	
[EOP Timer]		Specify the timeout period for print jobs.	
[EOP Timer]	[TCP/IP]	Specify the TCP/IP protocol settings. To apply your changes, choose Store Setting .	
	[IP Mode]	Choose whether the printer IP address is configured automatically or a static IP address is entered manually.	
	[Protocol]	[DHCP]	Specify the protocol used to configure the IP address automatically.
		[BOOTP]	
		[RARP]	
	[IP Setting]	[IP Address]	Specify the printer network information when using a static IP address. Enter the IP address assigned to the printer, as well as the network subnet mask and default gateway.
[Subnet Mask]			
[Default G/W]			
[NetWare]	[NetWare]	Specify the NetWare protocol. To apply your changes, choose Store Setting .	
	[Frame Type]	Specify the frame type to use.	
	[Print Service]	Choose the print service.	
[AppleTalk]		Specify whether to use the AppleTalk protocol. To apply your changes, choose Store Setting .	
[Ethernet Driver]	[Auto Detect]	Specify the communication method. To apply your changes, choose Store Setting . Choose On for automatic configuration of the LAN communication protocol. Choose Off to use settings values of Comm.Mode and Ethernet Type .	
	[Comm.Mode]	Choose the LAN communication method.	
	[Ethernet Type]	Choose the LAN transfer rate.	
	[Spanning Tree]	Choose whether spanning-tree packets are supported over the LAN.	
	[MAC Address]	Displays the MAC address.	
[Ext.Interface]		When installing the expansion interface board, choose whether the expansion interface board is used.	
[Init. Settings]		A confirmation message is displayed if you press the[▼] button. Choose [OK] to restore the network settings to the default values.	

[Maintenance]

T-1-16

Setting Item	Description, Instructions
[Maint. cart.]	When exchanging the maintenance cartridge, choose Yes and follow the instructions on the screen.
[Replace P.head]	Not displayed during a warning message that the remaining Maintenance Cartridge capacity is low. When replacing the Printhead , choose Yes and follow the instructions on the screen.
[Repl. S. Cleaner]	When replacing the shaft cleaner, select [Yes] and take appropriate actions according to the instructions shown on the screen.
[Change Cutter]	When replacing the cutter unit, select [Yes] and take appropriate actions according to the instructions shown on the screen. Replacing the cutter unit will reset the cut count.
[Move Printer]	Not displayed during a warning message that the remaining Maintenance Cartridge capacity is low. When transferring the printer to another location, choose Yes and follow the instructions on the screen.

[System Setup]

T-1-17

Setting Item	Description, Instructions	
[Warning]	[Buzzer]	Set the buzzer. Choose On for the buzzer to sound in case of errors.
	[Detect Mismatch]	Choose Warning for notification (display of a warning message) during printing if the paper type specified in the printer menu does not match the paper type in the printer driver. Choose None to continue print without notification. Choose Pause to have printing paused under these circumstances. In this case, you can continue printing by pressing the Online button.
[Keep Media Size]	Choose On to use the paper size setting as the basis for printing instead of other settings. The margin setting of the printer menu will be used instead of the margin setting of the printer driver if the latter is smaller, which may prevent text or images in the margin from being printed. Choose Off to use the printer driver settings instead. Even if the margin setting of the printer driver is smaller than that of the printer driver, text or images will not be cut off. However, this requires longer paper because the actual margin will be equal to the margin setting of the printer driver plus the margin setting of the printer menu.	
[Paper Size Basis]	[Sht Selection 1]	Select which size is to be recognized, [ISO A3+] or [13"x19"(Super B)], when the detected size of the cut sheet is between these sizes.

Setting Item		Description, Instructions
	[Roll Selection 1]	If roll size detection is activated, choose whether ISO A3 (297 mm) and 300 mm Roll is applied when an inbetween size is detected.
	[Roll Selection 2]	If roll size detection is activated, choose whether 10in. (254 mm) or JIS B4 (257 mm) is applied when an inbetween size is detected.
	[Sht Selection 2]	Select which size is to be recognized, [ISO B1] or [28"x40"(ANSI F)], when the detected size of the cut sheet is between these sizes.
[Noz. Check Freq.]		Specify the timing for automatic checks of nozzle clogging. Choose Off to disable checking. Choose 1 page to check after each page is printed. Choose 10 pages to check once after every ten pages are printed.
[Sleep Timer]		Specify the period before the printer enters sleep mode.
[Length Unit]		Choose the unit of measurement when roll length is displayed. You can switch the unit displayed for Roll Length Set and the remaining paper amount displayed in the submenu.
[Time Zone]		Specify the time zone. Time zone options indicate a main city in this time zone and the difference from Greenwich Mean Time.
[Date Format]		Specify the date format.
[Date & Time]	[Date]	Set the current date.
	[Time]	Set the current time.
[Language]		Specify the language used on the Display Screen.
[Contrast Adj.]		Adjust the contrast of the Display Screen.
[Reset PaprSetngs]		Restores settings that you have changed with Media Configuration Tool to the factory default values.

[Information]

T-1-18

Setting Item		Description, Instructions	
[System Info]	[Version]	[Firmware]	Displays the version of the printer and firmware.
		[Boot]	Displays the Boot ROM version of the printer.
		[MIT]	Displays the DB format version of the MIT.
	[s/n]		Displays the printer serial number.
	[MAC]		Displays the MAC address of the printer.
	[IP]		Displays the printer IP address.
[Error Log]	[#####-#####]		Displays the most recent error messages (up to two).
[Job Log]	(Choose from information about the latest three print jobs.	[Document Name]	Displays the document name in the last print job.
		[User Name]	Displays the name of the user who sent the print job.
		[Page Count]	Displays the number of pages in the print job.
		[Job Status]	Displays the results of the print job processed.
		[Print Start Time]	Displays the time when the print job was started.
		[Print End Time]	Displays the time when the print job was finished.
		[Print Time]	Displays the time required to print the job.
		[Print Size]	Displays the paper size in the print job.
		[Media Type]	Displays the paper type in the print job.
		[Interface]	Displays the interface used for the print job.
		[Ink Consumed]	Displays the ink density of each color in the print job.

5. Main Menu Settings (During Printing)

Main menu items during printing are described in the following tables.

T-1-19

Setting Item	Description, Instructions
[Head Cleaning]	Specify Printhead cleaning options. Choose Head Cleaning A if printing is faint, oddly colored, or contains foreign substances. Choose Head Cleaning B if no ink is printed at all, or if printing is not improved by Head Cleaning A .
[Fine Band Adj.]	Displayed during print jobs. Fine-tune the feed amount manually.
[Information]	Displays the information about the printer and history of print jobs.

[Information]

T-1-20

Setting Item		Description, Instructions	
[System Info]	[Version]	[Firmware]	Displays the version of the printer and firmware.
		[Boot]	Displays the Boot ROM version of the printer.
		[MIT]	Displays the DB format version of the MIT.
	[Ext.Interface]		Identifies boards in the expansion slot.
	[s/n:]		Displays the printer serial number.
	[MAC]		Displays the MAC address of the printer.
	[IP:]		Displays the printer IP address.
[Error Log]	{#####-#####}		Displays the most recent error messages (up to two).
[Job Log]	(Choose from information about the latest three print jobs.)	[Document Name]	Displays the document name in the last print job.
		[User Name]	Displays the name of the user who sent the print job.
		[Page Count]	Displays the number of pages in the print job.
		[Job Status]	Displays the results of the print job processed.
		[Print Start Time]	Displays the time when the print job was started.
		[Print End Time]	Displays the time when the print job was finished.
		[Print Time]	Displays the time required to print the job.
		[Print Size]	Displays the paper size in the print job.
		[Media Type]	Displays the paper type in the print job.
		[Interface]	Displays the interface used for the print job.
		[Ink Consumed]	Displays the ink density of each color in the print job.

1.7 Safety and Precautions

1.7.1 Safety Precautions

1.7.1.1 Moving Parts

Be careful not to get your hairs, clothing, accessories or any other objects caught in the moving parts of the printer.

The moving parts of the printer include the carriage unit, carriage belt, ink tube, flexible cable and feed motor driven by the carriage motor and the feed and pinch rollers driven by the feed motor and the purge unit driven by the purge motor.

To assure safety, the printer locks the top cover from opening while it is printing. When the top cover is opened while the printer is in online or offline mode, the driving power to the carriage and feed motors is shut down.

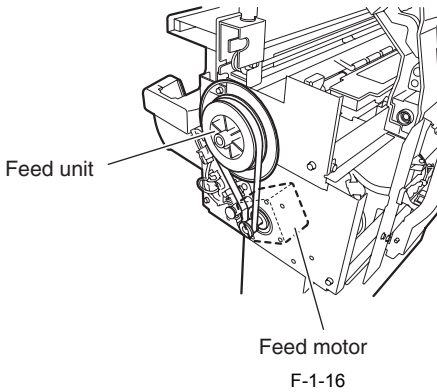
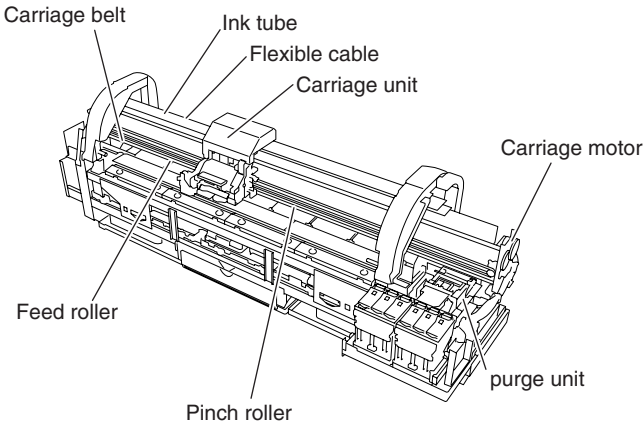

F-1-16

1.7.1.2 Adhesion of Ink

a. Ink passage

Be careful not to touch the ink passage in the printer to get the printer being serviced, workbench, your hands and clothes and so on smeared by the ink.

The ink passage comprises the ink tank unit, carriage unit, purge unit, maintenance cartridge unit and the ink tubes that interconnect the separate parts.

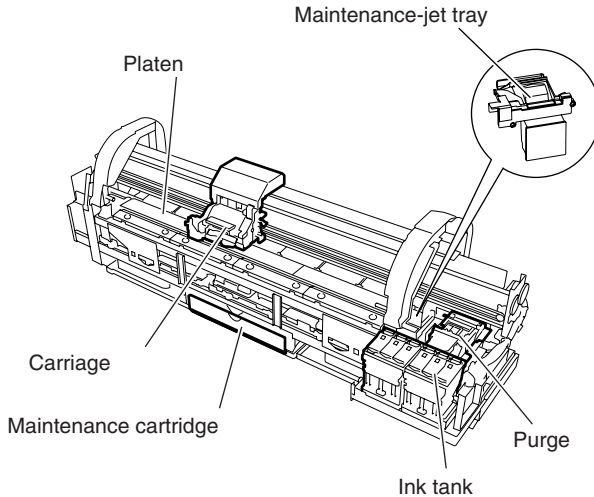

F-1-17



Inks contain an organic solvent, which is not harmful to the human body, though.

When an ink comes into the hands or any other part of your body, wash it away thoroughly. Be careful not to lick an ink or allow it to come into contact with your eyes.

In the event of eye contact, immediately wash with water thoroughly and obtain medical attention.

Also, if you have swallowed an ink in a large quantity by mistake, obtain medical attention immediately.

Inks contain a pigment and would not come off once they adhere to clothing.

b. Ink mists

As the printhead jets an ink against paper to print, traces of ink mists floating during printing or springing back from the paper are produced in the print station. Such ink mists are collected by mist collection air flow into the printer. The uncollected portion of ink mists could smear the platen unit, carriage unit, exterior surfaces and the purge unit, and their surrounding areas.

Such smears could in turn spoil the paper or your hands or clothes during servicing. Wipe such smears off with a soft cloth moistened with water and wrung carefully.

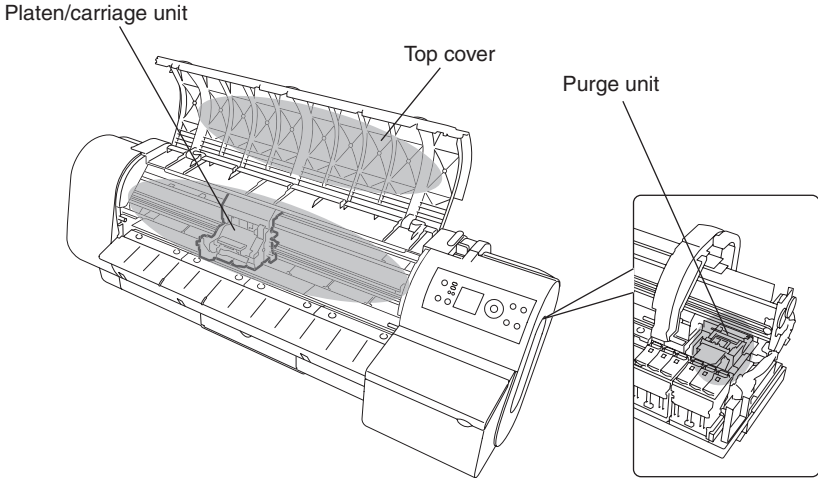

F-1-18

1.7.1.3 Electric Parts

Any electrical portion of the printer becomes live when AC power is supplied to it. The main controller, power supply and interface connector are found on the left rear side of the printer, with the operation panel being located on the upper right cover. In checking printer operations with the cover open during servicing, take maximum care to avoid electrical shocks and not to cause damage to electrical components.

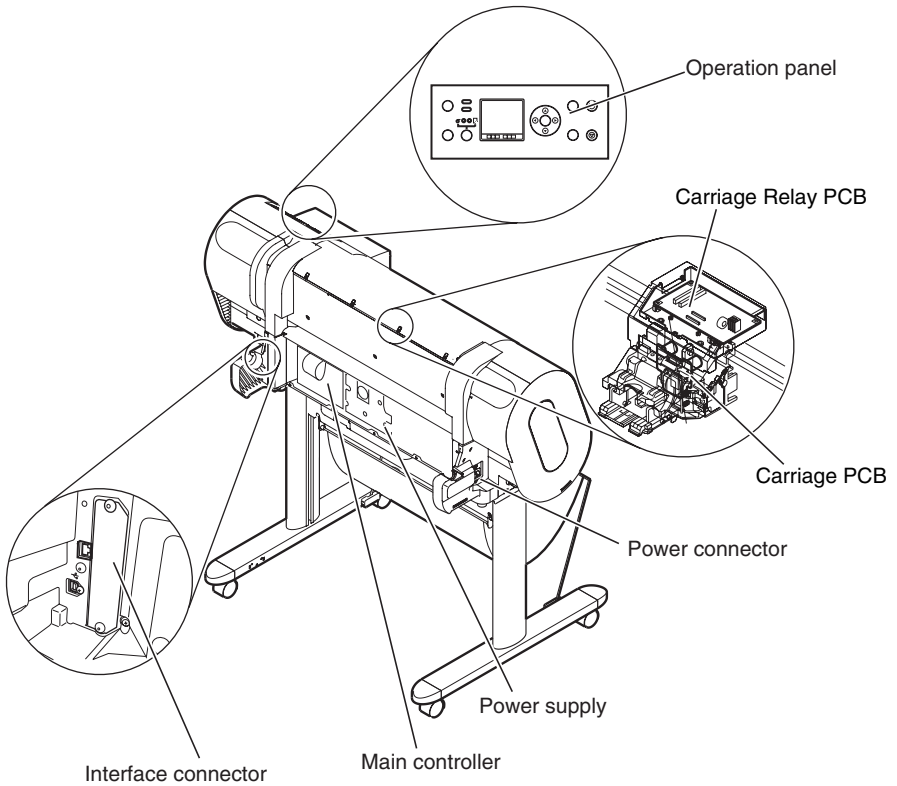

F-1-19

1.7.2 Other Precautions

1.7.2.1 Printhead

a. Handling the printhead

Do not unpack the printhead until it is ready for immediate use.

When mounting the printhead on the printer, remove protective caps 1 and 2 in this order by holding them by the lugs. To prevent possible damage to the nozzle section, do not replace protective cap 2 on the printhead once it has been removed.

After the printhead is removed of its protective caps, assemble it into the printer promptly to prevent the nozzles from being clogged by foreign matter adhering to the printhead to or a dried ink.

Depress the printhead fixer lever until it clicks into position.

To prevent the problems of nozzle clogging and poor ink suction that may be caused by adhering foreign matter, never touch the nozzle section and the ink port of the printhead or never wipe their surfaces with tissue paper or the like. Remember also to keep hands of the electrode section.

The printhead cannot be disassembled/reassembled or rinsed in water.

Memo:

A clogged nozzle or poorly sucked ink could result in a print defect, such as a periodic print void or poor coloring. If these problems persist even after cleaning, replace the printhead with a new one.

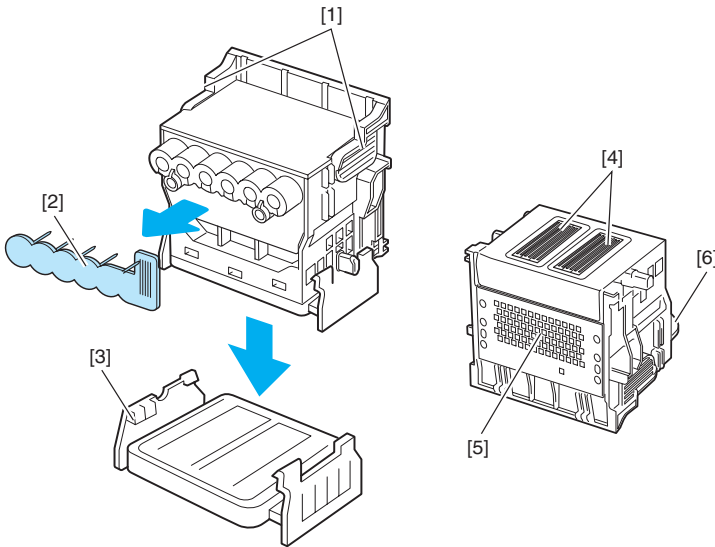

F-1-20

T-1-21

- | | |
|----------------------|-----------------------|
| [1] Lugs | [4] Nozzle section |
| [2] Protective cap 1 | [5] Electrode section |
| [3] Protective cap 2 | [6] Ink port |

b. Capping action

The printer performs a capping action at the end of printing or when it stands by in the wake of an error occurrence, to protect the printhead and prevent ink leaks.

If the printer has been powered off by inadvertently disconnecting the power cord from the wall outlet, reconnect the power cord to the wall out and turn on the power key. When the printer starts up successfully to enter online or offline mode, turn off the power key.



Failure to perform a capping action successfully could result in problems, such as printhead nozzles clogged by a dried ink or inks leaking from the printhead.

c. When leaving the printer of service

Even when the printer is out of service, store it with the printhead mounted on it.



Leaving the printer with the printhead removed from it could allow foreign matter to adhere to the printhead or dry an ink, resulting in clogged nozzles to cause print defects.

If the printhead is drained of inks for shipping purposes even though it is kept mounted on the printer, the nozzles could dry, resulting in print defects.

d. Ink conductivity

The inks used are conductive. If an ink is found to leak to the mechanical assembly, wipe it off with a soft cloth moistened with water and wrung thoroughly. If an ink is found to leak to the electrical assembly, blot it with tissue paper or the like and wipe it off thoroughly. If wiping off a leaking ink thoroughly is difficult, replace with a new component.



Energizing the printer with the electrical assembly being wetted with an ink could cause damage to it. Never connect the power cord to the wall outlet while the electrical assembly is wet with an ink.

1.7.2.2 Ink Tank

a. Opening ink tanks

Do not unpack ink tanks until they are ready for immediate use.

When placing an ink tank in position, shake it slowly seven to eight times before opening it. Without shaking, the ingredients of the ink might settle, resulting in degraded print quality.

Once an ink tank is opened, mount it in the printer promptly to prevent any foreign matter from sticking to the ink port.

b. Handling ink tanks

To prevent foreign matter from infiltrating the ink passage to impair ink suction or print quality, never touch contact [3] or ink port [4] of ink tank [1].
Depressing ink tank cover [2] of the printer would cause a needle to pierce the ink port, linking the ink passage of linking ink tank [1] to the printer.
Do not lift up and down ink tank cover [2] except for purposes other than replacing ink tank [1].

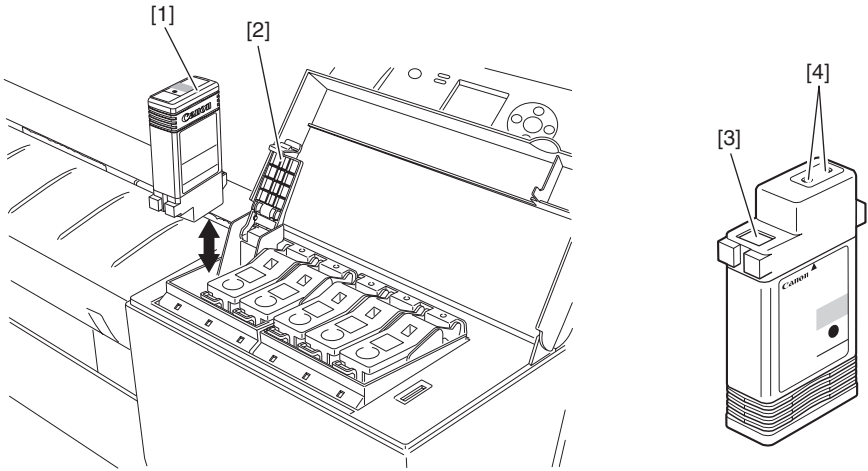

F-1-21

1.7.2.3 Handling the Printer

a. Protecting against electrostatic breakdowns

Pieces of clothing rubbing each other could build up static electricity, producing static charges in human bodies to cause harm to an electrical component or corrupt its electrical characteristics.
You are strongly advised never to touch the printhead contact of the carriage.

[1]Contact with the printhead

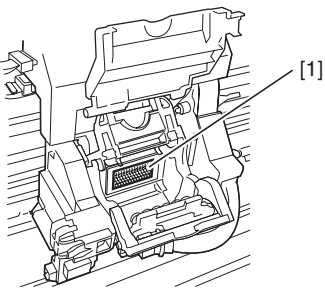

F-1-22

b. Securing the carriage in position

The carriage is mechanically locked by the lock arm in the purge unit at the same time as the printhead caps itself at the end of printing.

Before shipping the printer, secure the carriage at the home position with a belt stopper so the carriage won't be damaged when it is released from the lock arm or inks won't leak during transit.

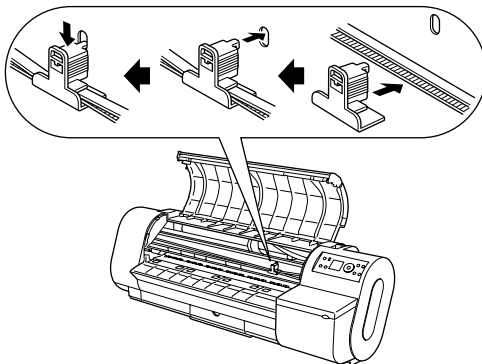

F-1-23

c. Contact of Linear Scale/Carriage Shaft

Please do not touch a linear scale and the carriage shaft when the inside of the top cover is opened, and execute maintenance.

When touching a linear scale and the carriage shaft, it might cause defective movement of the carriage and a defective print.

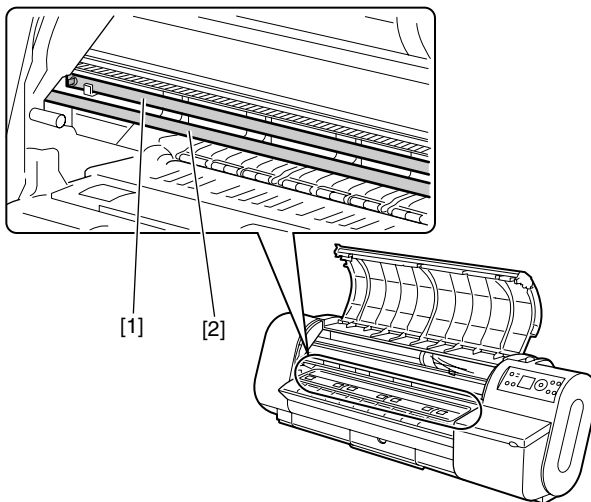

F-1-24

- [1] Linear Scale
- [2] Carriage Shaft

d. Handling maintenance cartridges

Be careful in unloading a maintenance cartridge from the printer not to keep the used ink from spilling over.

e. Refilling the printer with inks

If the printer has been purged of inks through an automatic or manual ink drain for disassembly/reassembly or for reshipping, refill the printer with inks as soon as possible after the completion of the work.

If residual inks in the printer dry, they could seize mechanical components, with the result of malfunctioning.

1.7.3 Precautions When Servicing Printer

1.7.3.1 Notes on the Data Stored in the Printer

This printer counts the print length, number of ink tank replacements, number of cleaning operations, number of cutter operations, and so on and stores them in the main controller's EEPROM as a service mode counter.

This counter provides important information about the printer usage status.

You can check this information by printing it in the service mode or displaying it on the display.

Following the precautions below when servicing the printer.

(1) Repairing/replacing the PCB

When replacing the main controller, follow the specified replacement procedure.

For the main controller replacement procedure, see "Disassembly/Reassembly" > "Points to Note on Disassembly and Reassembly" > "Boards".

(2) After replacing the purge unit

The information about the number of cleanings arises in the purge unit. After replacing the purge unit, select [INITIALIZE] > [PURGE] in the service mode to initialize (clear) the information about the number of cleanings.

(3) On replacement of supplies

After supplies have been replaced, execute [INITIALIZE] > [PARTS COUNTER] > [PARTS xx] in service mode to initialize (clear) the parts counter information.

For the consumable parts, see "Maintenance" > "Consumable Parts".



You cannot check the counter information once it is initialized (cleared). Be careful not to initialize the counter information before checking it.

You cannot modify the counter information from the operation panel.

1.7.3.2 Confirming the Firmware Version

Firmware has been downloaded to the main controller.

When you have replaced the main controller, check that the firmware is the latest version. If not, update it to the latest version.

Reference:

For how to up update the main controller, refer to "TROUBLESHOOTING" > "Update".

1.7.3.3 Precautions against Static Electricity

Certain clothing may generate static electricity, causing an electrical charge to build up on your body. Such a charge can damage electrical devices or change their electrical characteristics.

Before disassembling the printer for servicing, discharge any static buildup by touching a grounded metal fitting or the like.

1.7.3.4 Precautions for Disassembly/Reassembly

The precautions for disassembly/reassembly are described in "Disassembly/Reassembly".

1.7.3.5 Self-diagnostic Feature

The printer has a self-diagnostic feature to analyze hardware problems. The self-diagnosis result is shown on the display and indicated by lamps. For detailed information, see "Error Codes".

1.7.3.6 Disposing of the Lithium Battery

The main controller PCB of this printer is equipped with a lithium battery to back up various data.



Risk of explosion if battery is replaced by an incorrect type. Dispose of used batteries according to the instructions.

"For CA, USA Only

Included battery contains Perchlorate Material-special handling may apply. See <http://www.dtsc.ca.gov/hazardouswaste/perchlorate/> for detail."

Achtung:

Die Lithiumbatterie darf nur durch das Originalersatzteil (Parts Katalog) ersetzt werden; ansonsten besteht Brand-/Explosionsgefahr.

Lithiumbatterien niemals aufladen, demontieren oder durch Verbrennen entsorgen; bei der Entsorgung die örtlichen Entsorgungsvorschriften beachten (Schadstoffe; Sondermüll).

Chapter 2 TECHNICAL REFERENCE

Contents

2.1 Basic Operation Outline	2-1
2.1.1 Printer Diagram	2-1
2.1.2 Print Signal Sequence	2-2
2.1.3 Print Driving	2-3
2.2 Firmware	2-6
2.2.1 Operation Sequence at Power-on	2-6
2.2.2 Operation Sequence at Power-off	2-7
2.2.3 Print Control	2-8
2.2.4 Print Position Adjustment Function	2-14
2.2.5 Head Management	2-14
2.2.6 Printhead Overheating Protection Control	2-14
2.2.7 Pause between Pages	2-15
2.2.8 White Raster Skip	2-15
2.2.9 Sleep Mode	2-15
2.3 Printer Mechanical System	2-16
2.3.1 Outline	2-16
2.3.1.1 Outline	2-16
2.3.2 Ink Passage	2-17
2.3.2.1 Ink Passage	2-17
2.3.2.2 Ink Tank Unit	2-19
2.3.2.3 Carriage Unit	2-22
2.3.2.4 Printhead	2-25
2.3.2.5 Purge Unit	2-26
2.3.2.6 Maintenance Cartridge	2-32
2.3.2.7 Air Flow	2-33
2.3.3 Paper Path	2-33
2.3.3.1 Outline	2-33
2.3.3.2 Paper Path	2-35
2.3.3.3 Cutter Unit	2-36
2.4 Printer Electrical System	2-37
2.4.1 Outline	2-37
2.4.1.1 Overview	2-37
2.4.2 Main Controller	2-39
2.4.2.1 Main controller components	2-39
2.4.3 Carriage Relay PCB	2-41
2.4.3.1 Carriage relay PCB components	2-41
2.4.4 Head Relay PCB	2-41
2.4.4.1 Head relay PCB components	2-41

2.4.5 Maintenance Cartridge Relay PCB	2-42
2.4.5.1 Maintenance cartridge relay PCB components	2-42
2.4.6 Power Supply	2-42
2.4.6.1 Power supply block diagram	2-42
2.5 Detection Functions with Sensors	2-43
2.5.1 Sensors for covers	2-43
2.5.2 Ink passage system	2-44
2.5.3 Carriage system	2-47
2.5.4 Paper path system	2-49

2.1 Basic Operation Outline

2.1.1 Printer Diagram

Shown below is a printer diagram.

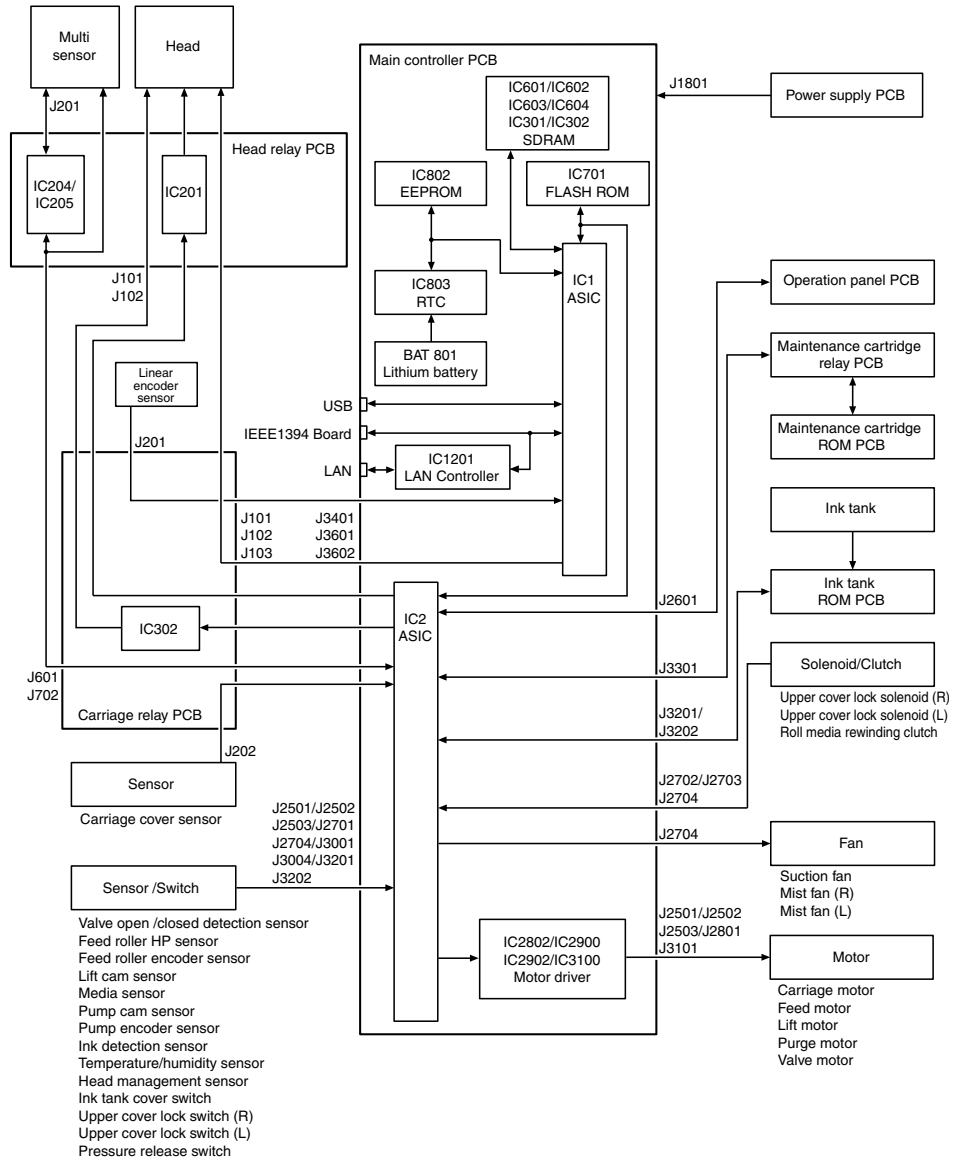

2.1.2 Print Signal Sequence

The signal sequence from when the printer receives the print signals until printing starts is shown in Figure.

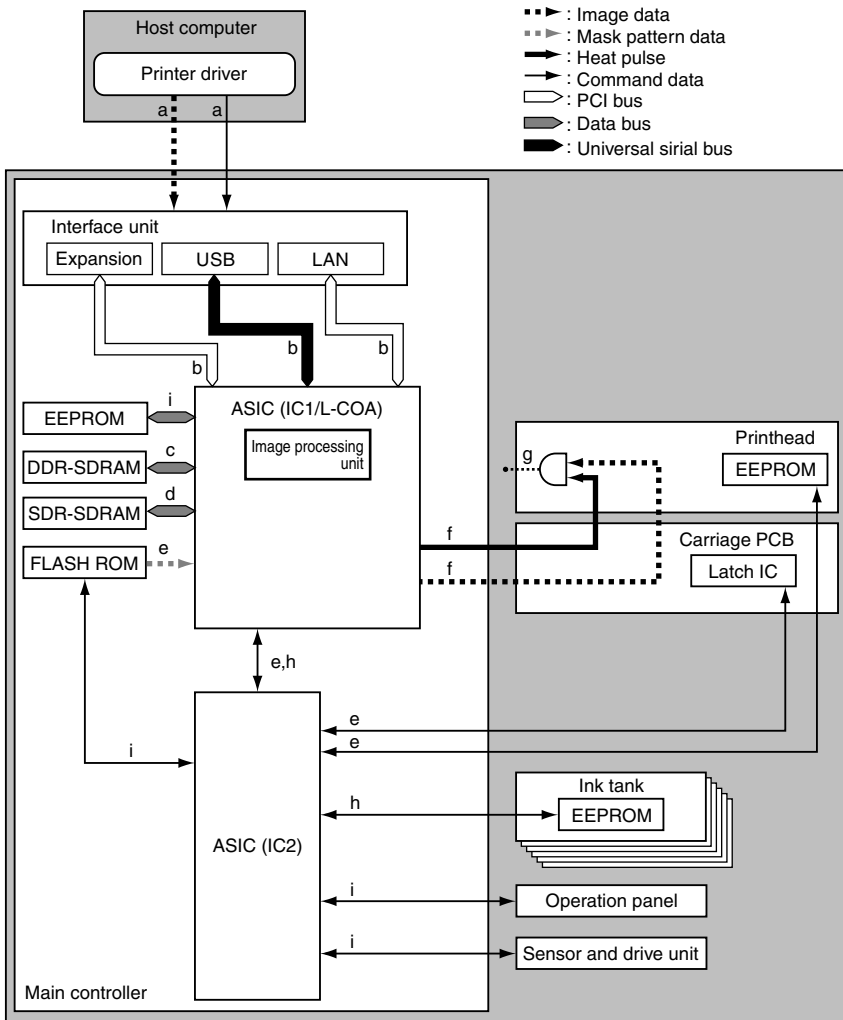

F-2-2

a) The printer driver on the host computer transmits print data, including command data, to the printer after compressing the image data, without resolution, color and 12-color binarization conversion.

To achieve high-quality image output, the image processing table data used for image data color conversion and binarization conversion are generated as command data to meet the Media Type and other specifications of the printer driver.

b) This printer receives print data from the individual interfaces on the main controller, transmitting the received print data to ASIC (IC1).

- c) The main controller decompresses the print data transmitted to the ASIC and gets it through resolution, color and 5-color binarization conversion while loading the data into DDR-SDRAM from time to time. It also converts the print data to 5-color binary equivalents of image and command data.
- d) The ASIC (IC1) generates image data synthesized with mask data within the ASIC in sync with the discharge time while loading the data into DDR-SDRAM from time to time.
- e) The ASIC (IC2) collects printhead information from EEPROM mounted on the printheads and the printer temperature from the latch IC on the carriage board and transmit them to the ASIC (IC1). The ASIC (IC1) also receives mask pattern data from the firmware installed in flash ROM.
- f) The ASIC (IC1) converts the image data synthesized with the mask pattern to data associated with the printhead information and the printer temperature, transmitting the data to the printheads as a print signal. It transmits heat pulses to the printheads at the same time to optimize head driving.
- g) The printheads convert the received print signal from a serial signal to a parallel signal for each row of nozzles and ANDs it with the heat pulses for perform printing.
- h) The ASIC (IC1) controls the general aspects of image processing and print drive control by detecting the status of the individual printer components with reference to the adjustment values stored in EEPROM. SDR-SDRAM is used as work memory.
- i) The ASIC (IC2) controls the general aspects of drive control by controlling button actuations and message displays on the basis of the firmware installed in flash ROM.

2.1.3 Print Driving

Print and control signals are transferred via the carriage relay PCB and head relay PCB to the printheads to discharge inks from the nozzle assembly at printing.

Each printhead has 12 trains of nozzles arranged in a zigzag pattern.

This printer uses one printhead.

(In installed state, from left to right, C, M, Y, MBK, MBK, BK)

Print signals directed at each nozzle train are even-numbered nozzle data (Hx-x-DATA-x-EV) and odd-numbered nozzle data (Hx-x-DATA-x-OD). These are transferred in timing with a data transfer clock (Hx-CLK) and data latch pulses (Hx-LT).

The Heat Enable (Hx-x-HE-x) drive control signal enables inks to be discharged from the nozzles.

1. Print drive control

Each train of nozzles in a printhead has 2,560 nozzles.

Ink discharge nozzles are selected split in 40-, 20- or 10-nozzle blocks according to the Block Enable information in the even-numbered nozzle data and odd-numbered nozzle data.

Each selected block of nozzles is impressed with a Heat Enable signal generated with variable pulse widths according to the head rank, head temperature and printer temperature for optimized ink discharges. The nozzles are driven by heater boards in the nozzles to discharge inks. Optimal nozzle blocks are selected according to the print path.

The diagram below illustrates the relationship between a 40-block nozzle and nozzles driven.

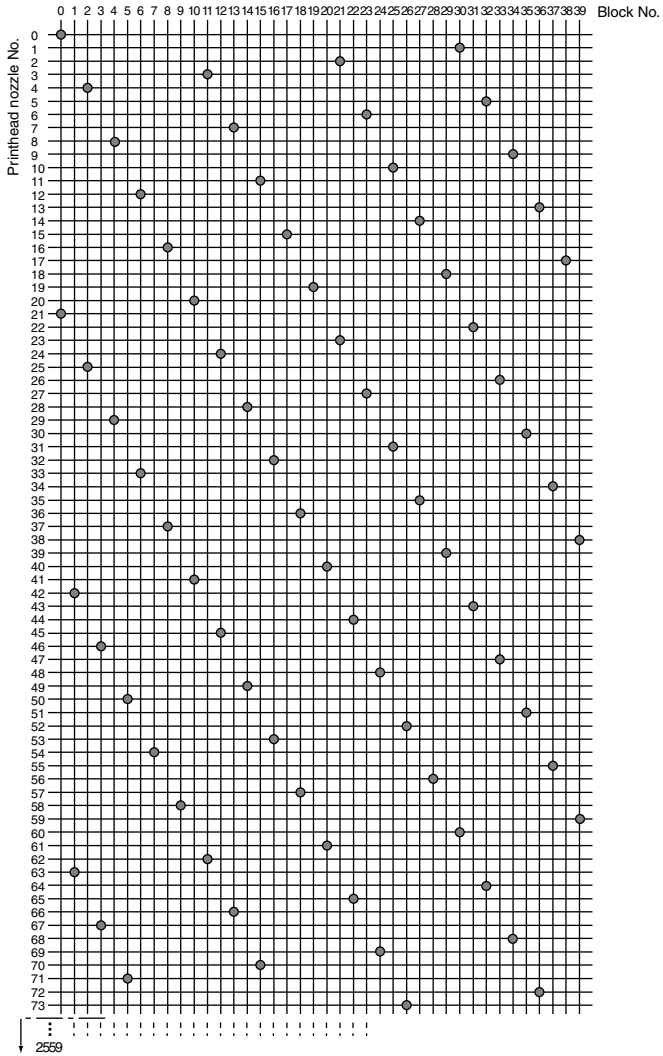

F-2-3

2. Print drive timing

Each printhead houses 12 trains of nozzles, which share the same data transfer clock (Hx-CLK) and data latch pulses (Hx-LT).

Even-numbered nozzle data (Hx-x-DATA-x-EV), odd-numbered nozzle data (Hx-x-DATA-x-OD) and the Heat Enable (Hx-x-HE-x) signal are generated for each nozzle train and controlled individually.

Printing is carried out in two ways through reciprocating motion of the carriage.

An encoder sensor mounted on the carriage generates a 150-dpi-pitched linear scale detection signal (ENCODER_A) and a signal (ENCODER_B) shifted 120 degrees in phase. The direction of carriage motion is detected from the status of the ENCODER_B signal relative to the leading edge of the ENCODER_A signal. The printhead is driven using a 2400-dpi timing signal (internal signal), which is generated by dividing the ENCODER_A signal detected at the 150 dpi timing into 16 equal sections.

Printing in the forward direction is triggered at the leading edge of the detection signal (ENCODER_A).

Printing in the backward direction is carried out the same way as printing in the forward direction but at the trailing edge of the detection signal (ENCODER_A), when the order of heated nozzles is reversed depending on the sequence of transfer of even-numbered nozzle data and odd-numbered nozzle data.

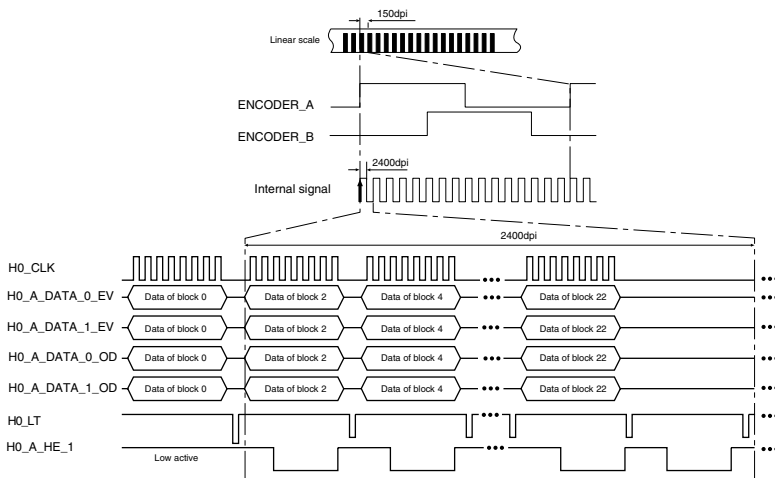

F-2-4

2.2 Firmware

2.2.1 Operation Sequence at Power-on

The sequence of printer operations, from power-on to transition to online mode, is flowcharted below.

* This flowchart does not include the times spent supply inks and cleaning after leaving the printer for extended periods of time.

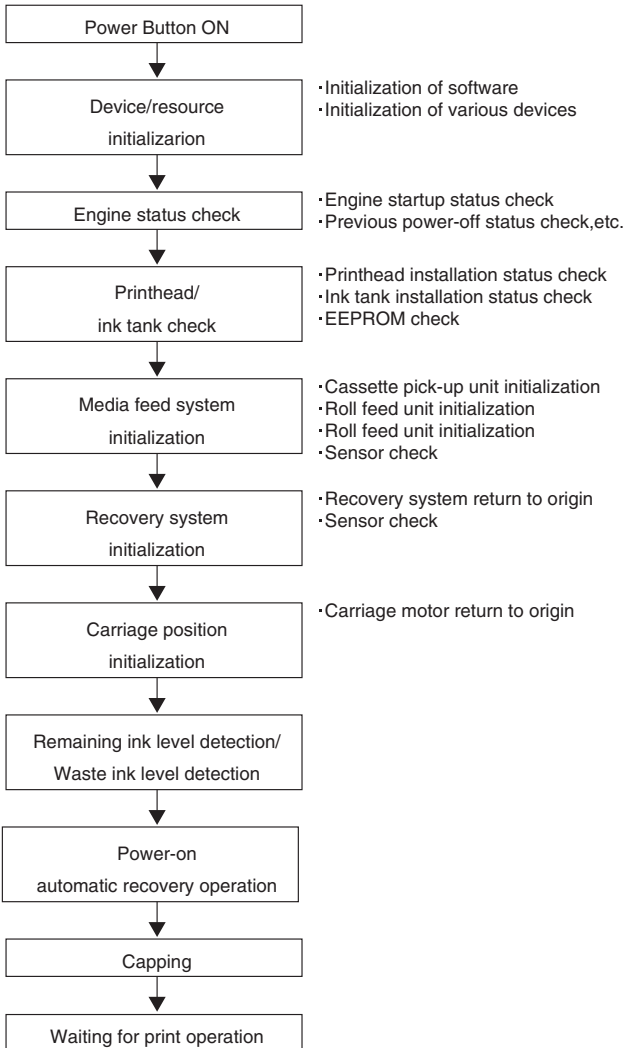

F-2-5

2.2.2 Operation Sequence at Power-off

Turning off the power switch cuts off the drive voltage supply, launching a firmware power-off sequence as shown below.



If the power cord is disconnected from the wall outlet or the top cover or any other cover is opened, the printer cancels the ongoing operation and shuts down immediately. Since printhead capping may or may not have been carried out properly, reconnect the power cord to the wall out and turn on the power switch. Making sure that the printer has entered online or offline mode, turn off the power switch.

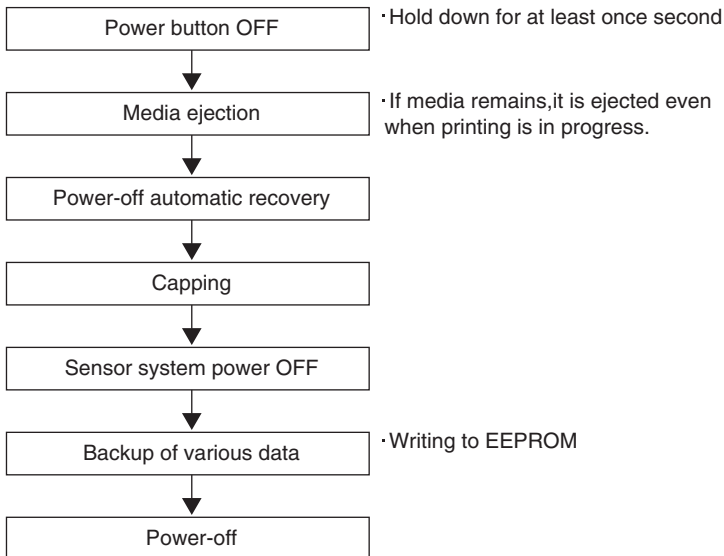

F-2-6

2.2.3 Print Control

1. Print mode

This printer is capable of fast, high-quality printing without blur and non-uniform density by changing the carriage operation, media feeding, other printing methods according to the selected media type, print quality, print data and so on.

Printing is performed for each color using a maximum of 16 paths in each print mode according to the selected print quality.

This reduces density irregularities caused by the variation in the amounts of ink discharged from individual nozzles. In addition, it shifts the printing timing so that the current ink layer is nearly fixed before the next ink layer is applied, thus minimizing bleeding.

Even in the same mode, the printer operates in a different way depending on the media setting made using the printer driver.

a) Draft mode

In the draft mode, image data is thinned out and a single band (equivalent to the width of a nozzle array) is printed using one path.

To use this mode, select "Draft" under "Print Quality" in the printer driver.

b) Standard mode

In the standard mode, a single band (equivalent to the width of a nozzle array) is printed using 1-6 (1, 2, 4 or 6) paths.

To use this mode, select "Standard" under "Print Quality" in the printer driver.

c) High quality mode

In the high quality mode, a single band is printed using 2, 4 or 8 paths.

To use this mode, select "High" under "Print Quality" in the printer driver.

d) Highest quality mode

In the highest quality mode, a single band is printed using 8, 12 or 16 paths.

To use this mode, select "Highest" under "Print Quality" in the printer driver.

T-2-1

Printing Modes

T-2-2

Media Type		Print Priority	Print Quality	Print-Pass	Printing Direction	Print Resolution (dpi)	Used BK ink
Plain Paper/ Recycled Paper	Plain Paper	Office Document	Standard	1/2	Bi-directional	1200x1200	BK
		Line Document/ Text	Draft	1	Bi-directional	1200x1200	BK
				1	Bi-directional	1200x1200	BK
			Standard	1	Bi-directional	1200x1200	BK
			High	2	Single-directional	1200x1200	BK
		2		Single-directional	1200x1200	BK	
		Image	Draft	1	Bi-directional	1200x1200	BK
			Standard	2	Bi-directional	1200x1200	BK
			High	4	Bi-directional	1200x1200	BK
	Plain Paper (High Quality)	Office Document	Standard	1/2	Bi-directional	1200x1200	BK
		Line Document/ Text	Draft	1	Bi-directional	1200x1200	BK
				1	Bi-directional	1200x1200	BK
			Standard	1	Bi-directional	1200x1200	BK
			High	2	Single-directional	1200x1200	BK
		2		Single-directional	1200x1200	BK	
		Image	Draft	1	Bi-directional	1200x1200	BK
			Standard	2	Bi-directional	1200x1200	BK
			High	4	Bi-directional	1200x1200	BK
	Plain Paper (High Grade)	Office Document	Standard	1/2	Bi-directional	1200x1200	BK
		Line Document/ Text	Draft	1	Bi-directional	1200x1200	BK
				1	Bi-directional	1200x1200	BK
Standard			1	Bi-directional	1200x1200	BK	
High			2	Single-directional	1200x1200	BK	
		2	Single-directional	1200x1200	BK		
Image		Draft	1	Bi-directional	1200x1200	BK	
		Standard	2	Bi-directional	1200x1200	BK	
		High	4	Bi-directional	1200x1200	BK	
All Plain Paper_Conserve MBK	Office Document	Standard	1/2	Bi-directional	1200x1200	BK	
	Line Document/ Text	Draft	1	Bi-directional	1200x1200	BK	
			1	Bi-directional	1200x1200	BK	
		Standard	1	Bi-directional	1200x1200	BK	
		High	2	Single-directional	1200x1200	BK	
	2		Single-directional	1200x1200	BK		
	Image	Draft	1	Bi-directional	1200x1200	BK	
		Standard	2	Bi-directional	1200x1200	BK	
		High	4	Bi-directional	1200x1200	BK	

Media Type	Print Priority	Print Quality	Print-Pass	Printing Direction	Print Resolution (dpi)	Used BK ink	
Economy Bond Paper	Office Document	Standard	1/2	Bi-directional	1200x1200	MBK	
	Line Document/ Text	Draft	1	Bi-directional	1200x1200	MBK	
			1	Bi-directional	1200x1200	MBK	
		Standard	1	Bi-directional	1200x1200	MBK	
			High	1	Single-directional	1200x1200	MBK
				2	Single-directional	1200x1200	MBK
	Image	Draft	1	Bi-directional	1200x1200	MBK	
		Standard	2	Bi-directional	1200x1200	MBK	
		High	4	Bi-directional	1200x1200	MBK	
	Universal Bond Paper	Office Document	Standard	1/2	Bi-directional	1200x1200	MBK
		Line Document/ Text	Draft	1	Bi-directional	1200x1200	MBK
				1	Bi-directional	1200x1200	MBK
Standard			1	Bi-directional	1200x1200	MBK	
			High	2	Single-directional	1200x1200	MBK
				2	Single-directional	1200x1200	MBK
Image		Draft	1	Bi-directional	1200x1200	MBK	
		Standard	2	Bi-directional	1200x1200	MBK	
		High	4	Bi-directional	1200x1200	MBK	
Standard Paper 1569B 80g		Office Document	Standard	1/2	Bi-directional	1200x1200	MBK
		Line Document/ Text	Draft	1	Bi-directional	1200x1200	MBK
				1	Bi-directional	1200x1200	MBK
	Standard		1	Bi-directional	1200x1200	MBK	
			High	2	Single-directional	1200x1200	MBK
				2	Single-directional	1200x1200	MBK
	Image	Draft	1	Bi-directional	1200x1200	MBK	
		Standard	2	Bi-directional	1200x1200	MBK	
		High	4	Bi-directional	1200x1200	MBK	
	Standard Paper 1570B 90g	Office Document	Standard	1/2	Bi-directional	1200x1200	MBK
		Line Document/ Text	Draft	1	Bi-directional	1200x1200	MBK
				1	Bi-directional	1200x1200	MBK
Standard			1	Bi-directional	1200x1200	MBK	
			High	2	Single-directional	1200x1200	MBK
				2	Single-directional	1200x1200	MBK
Image		Draft	1	Bi-directional	1200x1200	MBK	
		Standard	2	Bi-directional	1200x1200	MBK	
		High	4	Bi-directional	1200x1200	MBK	

Media Type		Print Priority	Print Quality	Print-Pass	Printing Direction	Print Resolution (dpi)	Used BK ink
Coated Paper	Coated Paper	Line Document/Text	Draft	1	Bi-directional	1200x1200	MBK
				1	Bi-directional	1200x1200	MBK
			Standard	2	Bi-directional	1200x1200	MBK
			High	4	Bi-directional	1200x1200	MBK
		Image	Standard	4	Bi-directional	1200x1200	MBK
				High	8	Bi-directional	2400x1200
	Highest			12	Bi-directional	2400x1200	MBK
	Heavyweight Coated Paper	Line Document/Text	Draft	1	Bi-directional	1200x1200	MBK
				1	Bi-directional	1200x1200	MBK
			Standard	2	Bi-directional	1200x1200	MBK
			High	4	Bi-directional	1200x1200	MBK
		Image	Standard	4	Bi-directional	1200x1200	MBK
				High	8	Bi-directional	2400x1200
	Highest			12	Bi-directional	2400x1200	MBK
	Extra Heavyweight Coated Paper	Line Document/Text	Draft	1	Bi-directional	1200x1200	MBK
				1	Bi-directional	1200x1200	MBK
			Standard	2	Bi-directional	1200x1200	MBK
			High	4	Bi-directional	1200x1200	MBK
		Image	Standard	4	Bi-directional	1200x1200	MBK
				High	8	Bi-directional	2400x1200
	Highest			12	Bi-directional	2400x1200	MBK
	Recycled Coated Paper	Line Document/Text	Draft	1	Bi-directional	1200x1200	MBK
				1	Bi-directional	1200x1200	MBK
			Standard	2	Bi-directional	1200x1200	MBK
High			4	Bi-directional	1200x1200	MBK	
Image		Standard	4	Bi-directional	1200x1200	MBK	
			High	8	Bi-directional	2400x1200	MBK
	Highest		12	Bi-directional	2400x1200	MBK	
Premium Matte Paper	Line Document/Text	Draft	1	Bi-directional	1200x1200	MBK	
			1	Bi-directional	1200x1200	MBK	
		Standard	2	Bi-directional	1200x1200	MBK	
		High	4	Bi-directional	1200x1200	MBK	
	Image	Standard	4	Bi-directional	1200x1200	MBK	
			High	8	Bi-directional	2400x1200	MBK
Highest			16	Bi-directional	2400x1200	MBK	
Colored Coated Paper	Image	Standard	4	Bi-directional	1200x1200	BK	
		High	8	Bi-directional	1200x1200	BK	
Premium Coated Paper	Line Document/Text	Draft	1	Bi-directional	1200x1200	BK	
			1	Bi-directional	1200x1200	BK	
		Standard	2	Bi-directional	1200x1200	BK	

	Media Type	Print Priority	Print Quality	Print-Pass	Printing Direction	Print Resolution (dpi)	Used BK ink
Photo Paper	Glossy Photo Paper	Image	Standard	6	Bi-directional	1200x1200	MBK
			High	8	Bi-directional	2400x1200	MBK
			Highest	16	Bi-directional	2400x1200	MBK
	Semi-Glossy Photo Paper	Image	Standard	6	Bi-directional	1200x1200	MBK
			High	8	Bi-directional	2400x1200	MBK
			Highest	16	Bi-directional	2400x1200	MBK
	Heavyweight Glossy Photo Paper 2	Image	Standard	6	Bi-directional	1200x1200	MBK
			High	8	Bi-directional	2400x1200	MBK
			Highest	16	Bi-directional	2400x1200	MBK
	Heavywght SemiGlos Photo Paper 2	Image	Standard	6	Bi-directional	1200x1200	MBK
			High	8	Bi-directional	2400x1200	MBK
			Highest	16	Bi-directional	2400x1200	MBK
	Satin Photographic Paper 190gsm	Image	Standard	6	Bi-directional	1200x1200	MBK
			High	8	Bi-directional	2400x1200	MBK
			Highest	16	Bi-directional	2400x1200	MBK
	Premium RC Photo Luster , 10 mil	Image	Standard	6	Bi-directional	1200x1200	BK
			High	8	Bi-directional	2400x1200	BK
			Highest	16	Bi-directional	2400x1200	BK
	Instant Dry Papers Glossy 200g	Image	Standard	6	Bi-directional	1200x1200	BK
			High	8	Bi-directional	2400x1200	BK
			Highest	16	Bi-directional	2400x1200	BK
	Instant Dry Papers Satin 200g	Image	Standard	6	Bi-directional	1200x1200	BK
			High	8	Bi-directional	2400x1200	BK
			Highest	16	Bi-directional	2400x1200	BK
Photo Paper High Glossy 250g	Image	Standard	6	Bi-directional	1200x1200	BK	
		High	8	Bi-directional	2400x1200	BK	
		Highest	16	Bi-directional	2400x1200	BK	
Photo Paper Semi Matt 250g	Image	Standard	6	Bi-directional	1200x1200	BK	
		High	8	Bi-directional	2400x1200	BK	
		Highest	16	Bi-directional	2400x1200	BK	
Photo Paper Satin 240g	Image	Standard	6	Bi-directional	1200x1200	BK	
		High	8	Bi-directional	2400x1200	BK	
		Highest	16	Bi-directional	2400x1200	BK	
Photo Paper Pearl 260g	Image	Standard	6	Bi-directional	1200x1200	BK	
		High	8	Bi-directional	2400x1200	BK	
		Highest	16	Bi-directional	2400x1200	BK	

Media Type		Print Priority	Print Quality	Print-Pass	Printing Direction	Print Resolution (dpi)	Used BK ink
Proofing Paper	Proofing Paper	Image	Standard	6	Bi-directional	1200x1200	MBK
			High	8	Bi-directional	2400x1200	MBK
			Highest	16	Bi-directional	2400x1200	MBK
	Professional Proof and Photo Glossy 195g	Image	Standard	6	Bi-directional	1200x1200	BK
			High	8	Bi-directional	2400x1200	BK
			Highest	16	Bi-directional	2400x1200	BK
	Professional Proof and Photo Semiglossy 195g	Image	Standard	6	Bi-directional	1200x1200	BK
			High	8	Bi-directional	2400x1200	BK
			Highest	16	Bi-directional	2400x1200	BK
	Professional Proof and Photo Semigloss 255g	Image	Standard	6	Bi-directional	1200x1200	BK
			High	8	Bi-directional	2400x1200	BK
			Highest	16	Bi-directional	2400x1200	BK
Synthetic Paper	Synthetic Paper	Image	Standard	6	Bi-directional	1200x1200	MBK
			High	8	Bi-directional	2400x1200	MBK
			Highest	16	Bi-directional	2400x1200	MBK
	Adhesive Synthetic Paper	Image	Standard	6	Bi-directional	1200x1200	MBK
			High	8	Bi-directional	2400x1200	MBK
			Highest	16	Bi-directional	2400x1200	MBK
Adhesive Matt Paper	High Resolution Graphic Paper Self ADH	Image	Standard	6	Bi-directional	1200x1200	BK
			High	8	Bi-directional	2400x1200	BK
			Highest	16	Bi-directional	2400x1200	BK
CAD	CAD Tracing Paper	Line Document/Text	Draft	1	Bi-directional	1200x1200	BK
				1	Bi-directional	1200x1200	BK
			Standard	2	Bi-directional	1200x1200	BK
				4	Bi-directional	1200x1200	BK
			High	4	Bi-directional	1200x1200	BK
				4	Bi-directional	1200x1200	BK
	CAD Translucent Matte Film	Line Document/Text	Draft	1	Bi-directional	1200x1200	BK
				1	Bi-directional	1200x1200	BK
			Standard	2	Bi-directional	1200x1200	BK
				4	Bi-directional	1200x1200	BK
	CAD Translucent Matte Film	Line Document/Text	High	4	Bi-directional	1200x1200	BK
				4	Bi-directional	1200x1200	BK
			Highest	8	Bi-directional	1200x1200	MBK
				8	Bi-directional	1200x1200	MBK

Media Type		Print Priority	Print Quality	Print-Pass	Printing Direction	Print Resolution (dpi)	Used BK ink
Special	Special 1	Image	Standard	6	Bi-directional	1200x1200	MBK
			High	8	Bi-directional	2400x1200	MBK
			Highest	16	Bi-directional	2400x1200	MBK
	Special 2	Image	Standard	6	Bi-directional	1200x1200	MBK
			High	8	Bi-directional	2400x1200	MBK
			Highest	16	Bi-directional	2400x1200	MBK
	Special 3	Image	Standard	6	Bi-directional	1200x1200	MBK
			High	8	Bi-directional	2400x1200	MBK
			Highest	16	Bi-directional	2400x1200	MBK
	Special 4	Image	Standard	6	Bi-directional	1200x1200	MBK
			High	8	Bi-directional	2400x1200	MBK
			Highest	16	Bi-directional	2400x1200	MBK
	Special 5	Image	Standard	6	Bi-directional	1200x1200	MBK
			High	8	Bi-directional	2400x1200	MBK
			Highest	16	Bi-directional	2400x1200	MBK

2.2.4 Print Position Adjustment Function

This printer supports a print position adjustment function to adjust the vertical and horizontal print position and the bidirectional print position of the print head mounted on the carriage and the feed rate.

Print position adjustment work in two modes: automatic adjustment, in which print position adjustment patterns printed are detected by a multisensor attached to the lower left part of the carriage, and manual adjustment, in which print position adjustment patterns that are slightly modified from one another are printed, so that visually verified adjustment values can be set from the operation panel.

To make print position adjustment, A4-or-larger-sized roll media or cut media are needed.

2.2.5 Head Management

This printer supports a nozzle check function to spot non-discharging nozzles in the printhead. When the printer detects a non-discharging nozzle, it starts cleaning the printhead automatically to correct its discharge failure. If cleaning does not work, the printer backs up the non-discharging nozzle with an alternative nozzle automatically to ensure unflinching print performance.

Detection timings (automatic): Power-on, open carriage cover detection, print start (check timing variable by selecting Nozzle Check from the system menu)

2.2.6 Printhead Overheating Protection Control

When an abnormal temperature rise in the printhead is detected, overtemperature protection control launches. Overtemperatures could occur in the printhead after a spell of print operations without the nozzles being filled with inks.

Overtemperature protection control prevents non-discharge failures and damages that might result from an overheated printhead.

Overtemperature protection control is implemented on the basis of the temperature detected by the head temperature sensor for each nozzle. When an abnormal temperature is detected in any nozzle train, overtemperature protection control is exerted at one of two levels according to that temperature.

Protection level 1

If the head temperature sensor (DI sensor) has detected a temperature higher than the protection temperature, it halts the carriage temporarily at the scan end position in the direction of travel according to the carriage scan

status.

Printing resumes when the printhead radiates naturally to cool down to below a predetermined temperature or when 30 seconds or longer have elapsed since the detection of the temperature higher than the protection temperature.

Protection level 2

When the head temperature sensor (DI sensor) has detected an abnormal temperature, the printer shuts down the print operation immediately, moving the carriage to the home position for capping, with an error indication on the display.

2.2.7 Pause between Pages

An inter-page function is available to prevent ink rubbing, which keeps paper just printed hanging above the platen and waiting for a predetermined period of time before delivery.

The wait time is user-programmable from the print driver. This feature is particularly useful on paper that takes time to dry after printing.

A 30-second drying time is set automatically for borderless printing.

2.2.8 White Raster Skip

This printer supports a white raster skip function to bypass carriage scanning in a consecutive sequence of voids in print data for added throughput.

2.2.9 Sleep Mode

The printer has sleep mode to save on its standby power requirement.

The printer transitions to sleep mode automatically when it has been left idle or no print data has been received for a predetermined period of time while the printer is online or offline.

The printer exits sleep mode when any operation panel key is activated or print data is received from the host computer.

The time to transition to sleep mode is variable from the operation panel.

(Default: 5 minutes)

2.3 Printer Mechanical System

2.3.1 Outline

2.3.1.1 Outline

The printer mechanism is broken down into two broad sections: the passage and paper passage. Consisting mainly of a carriage unit that houses ink tanks and a printhead, and a maintenance cartridge, the ink passage supplies, circulates, sucks and otherwise handles inks. The paper passage consists of such mechanical components as a paper unit and is designed to feed, convey and deliver paper in two ways.

A summary description of each mechanical component is given below.

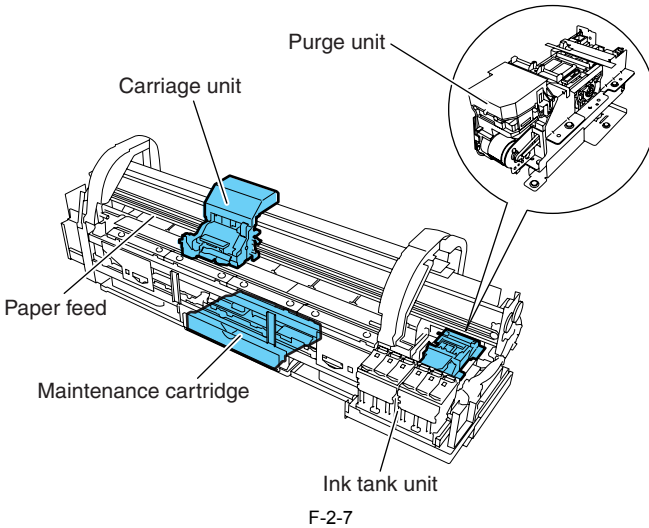

2.3.2 Ink Passage

2.3.2.1 Ink Passage

2.3.2.1.1 Overview of Ink Passage

The ink passage comprises ink tanks, a printhead, caps, a waste ink collector, ink tubes interconnecting the mechanical components, and a suction pump that is driven to suck inks. It supplies, circulates, sucks and otherwise handles inks.

The ink passage (per color) is schematically shown below, along with the ink flow.

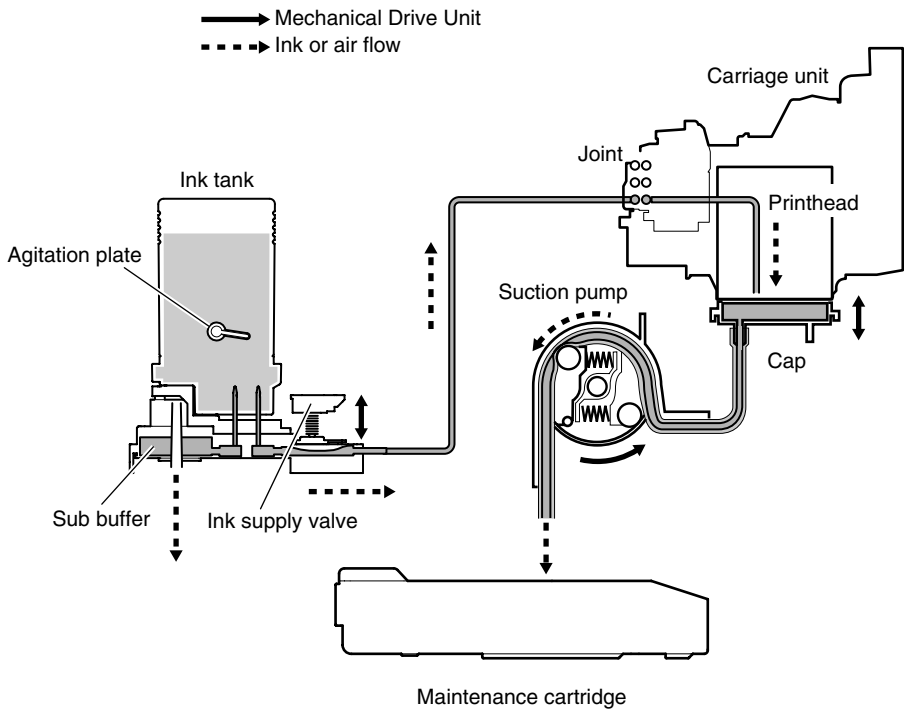

F-2-8

a) Supplying inks from the ink tanks to the ink supply valve assembly

The ink tanks each contain an ink to feed the printhead.

Head differences allow the inks to flow from the ink tanks to the ink supply valves.

b) Inks flowing from the ink tanks into the subbuffer

As the inks flow from the ink tanks to the subbuffers due to head differences, air infiltrates the ink tanks through air passages in the subbuffers to keep its internal pressure constant.

When the ink stored in a subbuffer exceeds a predetermined level, it flows into the absorber under the ink tank through the air passage.

c) Supplying inks from the ink supply valves to the printhead

The ink stored in an ink tank flows to the printhead when the suction pipe is driven with the ink supply valve opened and the head capped.

As an ink is sucked from the caps, it flows into the waste ink absorber under the maintenance cartridge or purge unit.

d) Ink supply while printing

The ink supply valves are kept open while printing, so that inks are being constantly fed to the printhead under the negative pressure of the nozzle assembly caused by discharging inks.

Further, waste inks sucked in a cleaning operation and inks from borderless printing flow into the waste ink absorber under the maintenance cartridge and into the waste ink box.



When an ink tube filled with ink, opening all whole ink passages (by opening both the ink supply valve and the printhead fixer lever with an ink tank yet to be installed) could cause the ink in the ink tube to flow backward due to a head difference, leaking through the hollow needle in the ink tank.

As a precaution, never open all the ink passages at the same time while the ink tubes are filled with inks.

e) Agitating the ink in an ink tank

To prevent the pigment ink stored in a tank from settling, the ink needs to be agitated.

The ink supply valve is continuously opened and closed to cause the ink to flow back into the tank for agitation. Each ink tank contains an agitating plate to aid in agitating of the ink. (An agitating plate is also installed in the dye ink tank.)

-Operation timing: Whenever a new tank is installed or 168 hours have expired since the agitation was last carried out (agitation is carried out regardless of whether printing or cleaning is in progress).

-Ink supply valve open/closed: 30 times (30 seconds)

If 336 hours or more have elapsed, the ink supply valve open/closed count and the time to the next session of agitation are varied according to the elapsed time.

2.3.2.2 Ink Tank Unit

2.3.2.2.1 Structure of Ink Tank Unit

a) Ink tanks

Each color-specific ink tank is filled with 130 mL of ink (90 mL for the starter ink tanks bundled with the printer). The ink level in each ink tank is memorized in EEPROM attached to the tank and is detected as a dot count on the basis of the EEPROM information.

When an electrode attached to a hollow needle detects no continuity, it displays a message reporting that the ink tank is nearly empty. If the dot count reaches a predesigned value in this state, an ink out condition is assumed.

b) Ink port

Depressing the ink tank fixer lever on the printer would cause a hollow needle to pierce the ink port sealed by a rubber plug, linking the ink passage of the ink tank to the printer.

c) Air passage

Depressing the ink tank fixer lever on the printer would cause an open hollow needle to pierce the air passage sealed by a rubber plug, releasing the internal pressure of the ink tank to keep it constant.

d) Notches for preventing incorrect installation

Ink tanks are furnished with a notch for preventing incorrect installation. If the installation of an ink tank in incorrect position is attempted, the notch would interfere with it, preventing its installation.

The ink tank fixer lever won't lower without the ink tank fully inserted to reach the mounting position, so the ink cannot be supplied.

e) Agitating plate

Assists in the agitation of pigment inks during ink agitation carried out to prevent their settlement.

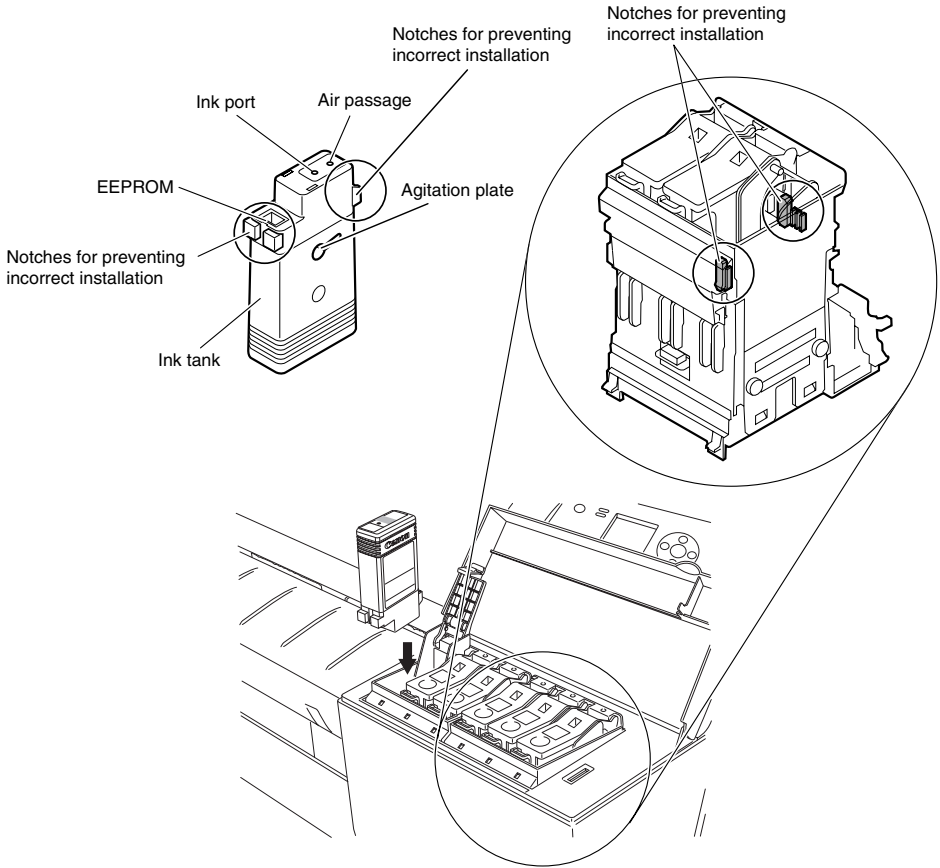

F-2-9

f) Ink supply valves

Located halfway between the ink tanks and the ink tubes, the ink supply valves prevent the leakage of inks that might otherwise be caused by the opening of the ink tubes on the side of the ink tanks during their replacement. The ink supply valves are caused to open and close by the valve open/close mechanism that is activated by driving the valve motors.

The ink tank unit comprises two tank bases, each integrated for a set of three colors, and six-color ink tubes. The color-specific ink supply valves are linked with the valve cams so they will open and close at the same time for all colors.

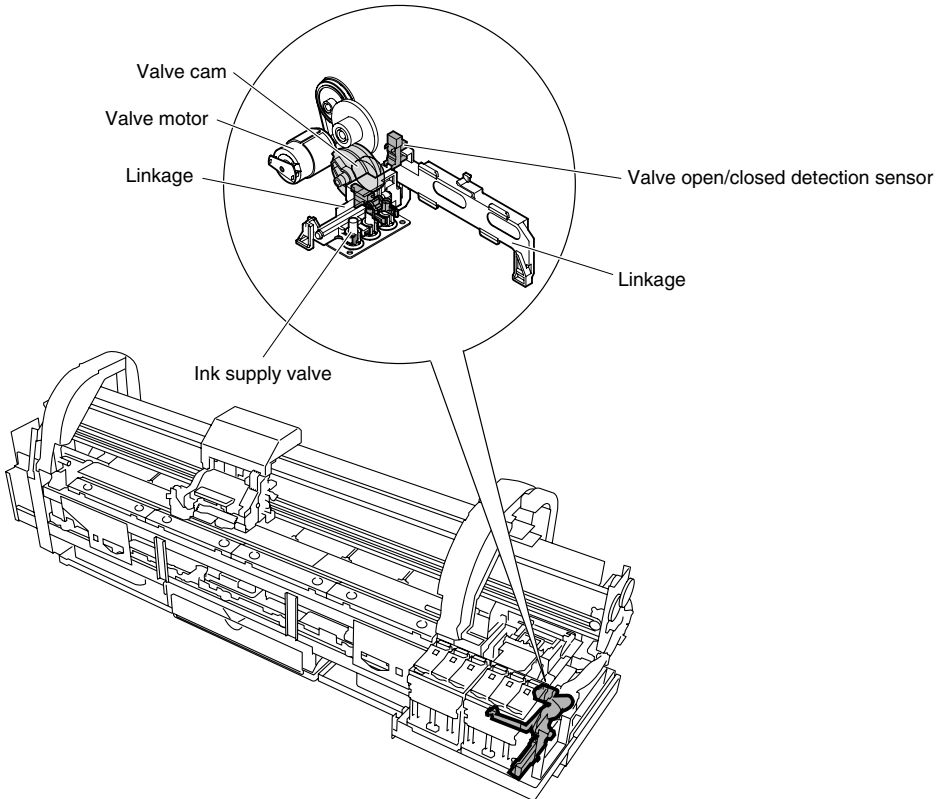

F-2-10

2.3.2.3 Carriage Unit

2.3.2.3.1 Functions of Carriage Unit

a) Printhead mounting function

The carriage, which fixes the printhead in position mechanically, is connected to the contact of the head relay PCB.

b) Control function

The carriage carries a carriage relay PCB, which relays printhead drive signals, and an encoder, which generates print timing signals. The carriage relay PCB is connected to the main controller by a flexible cable.

c) Carriage drive function

The carriage is caused to reciprocate level on the platen by means of the carriage belt that is driven by the power imparted from the carriage motor.

d) Printhead maintenance function

This printer performs cleaning operations, such as wiping the printhead and sucking inks, with the carriage halted at its home position.

e) Nozzle check function

This printer carries out an ink discharge operation with the carriage halted at the maintenance jet tray, locating the nozzles in the printhead failing to discharge with a head management sensor attached to the head management sensor.

f) Carriage height adjustment function

The separation between the face of the printhead and the paper varies with each paper thickness. A narrow gap makes quality better but could smear the print surface as a result of paper rubbing against the face or cause damage to the nozzle assembly.

T-2-3

Head height (mm)	Media type Environmental condition (Temperature:15-25, Humidity:40%-60%)
1.45	Glossy Paper, Plain Paper (Line drawing)
1.75	Plain Paper, Heavyweight Coated Paper (Line drawing)
2.05	Heavyweight Coated Paper
2.35	Premium Matte Paper
2.65	Premium Matte Paper (Temperature:15-30, Humidity:10%-40%)

g) Paper width detection function/skew detection function

The multisensor attached to the lower left part of the carriage detects the width of paper fed on the platen and skews in it.

h) Automatic printhead position adjustment function

The multisensor attached to the lower left part of the carriage reads the result of an adjustment pattern printed, allowing for automatic adjustment of the printhead position accordingly.

i) Remaining roll media detection function

The printer prints a bar code on roll media when they are unloaded. The multisensor attached to the lower left part of the carriage indicates the remaining volume of roll media.

j) Internal unit temperature sensor

A thermistor installed on the head relay PCB detects the internal unit temperature near the printhead.

2.3.2.3.2 Structure of Carriage Unit

a) Printhead mount

The printhead is secured to the carriage by the printhead fixer cover and the printhead fixer lever. When the printhead is secured to the carriage, the signal contact of the head relay PCB is pressed against that of the printhead to convey print signals. Further, the ink passage from the ink tanks is connected to the printhead via the ink tubes.

b) Ink port

Ink is supplied to the printhead via an ink tube, which runs between the tube guides via joints to reach the carriage and follows up its motion.

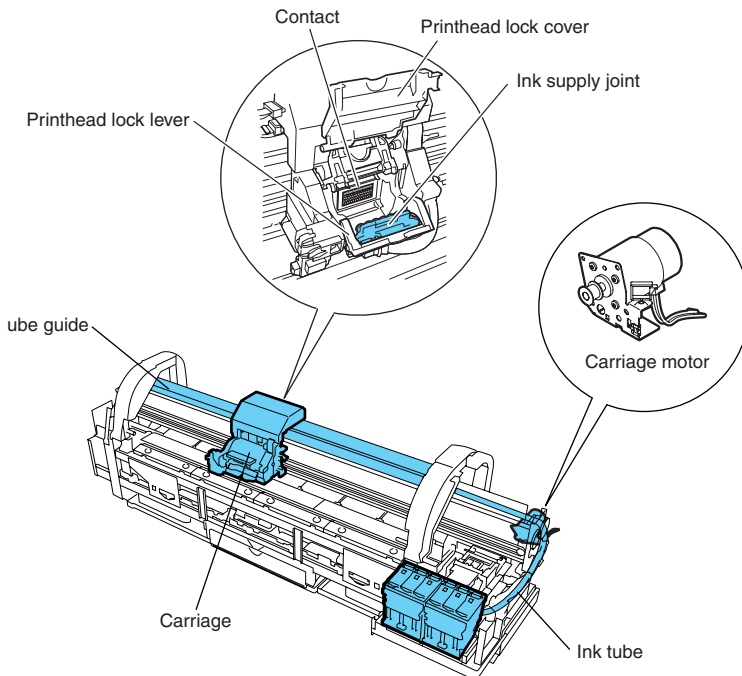

F-2-11

c) Control unit

The carriage relay PCB is connected to the head relay PCB by means of a flexible cable. The flexible cable between the main controller and the carriage relay PCB follows up the motion of the carriage together with the tube guide.

A photocoupler encoder mounted in the lower part of the back of the carriage detects a linear scale reading as the carriage moves.

d) Carriage drive

Mechanical misregistrations in the vertical/horizontal and bidirectional print positions of the printhead mounted can be corrected by selecting Adjusting Printer from the [MAIN MENU] to [Adjust Printer].

A DC-operated carriage motor drives the carriage in the horizontal direction of paper by way of the carriage. The carriage home position, is where the carriage is slowly brought to the right end at power-on initialization. When the linear scale position is set as a reference home position for use in subsequent position control operations, the driving of the carriage motor is controlled by control signals generated from the main controller.

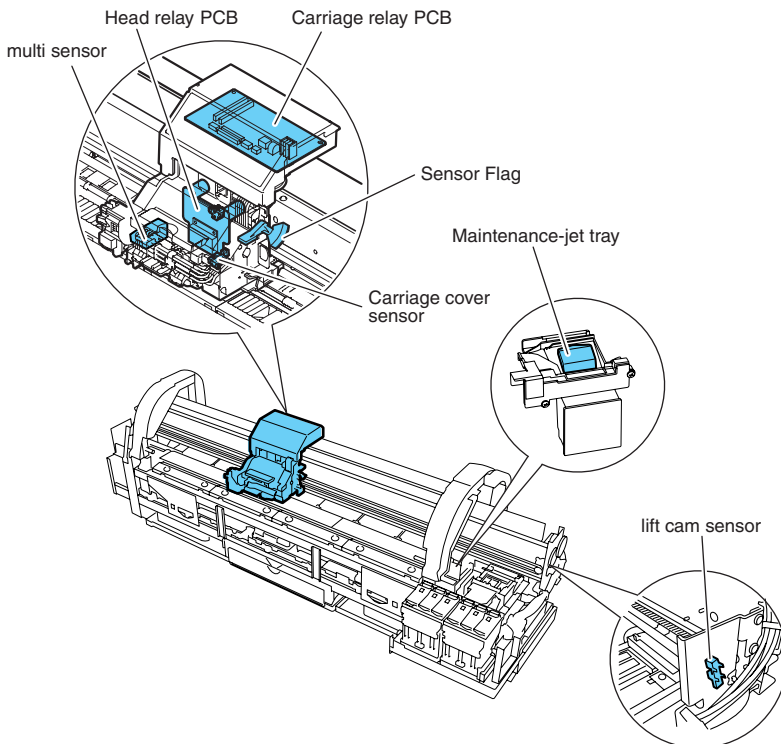

F-2-12

e) Printhead maintenance unit

This printer cleans the printhead with the carriage halted at its home position.

Wiping is executed in sync with the rotation of the motor. Wipers mounted on the carriage wipe the printhead while the carriage is halted at its home position.

A maintenance jet is discharged as the carriage travels to pass the maintenance jet tray to the right of the plant. A suction operation is carried out by a suction cap in the purge unit.

f) Carriage height adjustment unit

When the lift motor is driven to rotate the lift lever, the carriage shaft height is varied to change the separation between the face of the printhead and the paper.

The printhead height is detected by the multisensor attached to the lower left part of the carriage

g) Multisensor

The multisensor attached to the lower left part of the carriage consists of four LEDs (red, blue, green, infrared) and two light-receiving sensors to detect the leading edges and width of paper and skews in it, and to adjust its registration and head height.

The multisensor standard has a white plate attached to it, so that a reference value can be calculated during paper gap measurement by measuring the intensity of light reflected upon the white plate.

(Service mode: SERVICE MODE > ADJUST > GAP CALIB)

h) Rail cleaners

The shaft cleaners located on both sides of the carriage clean the carriage shaft and give a coat of an impregnating oil to the shaft.

i) Internal unit temperature sensor

One thermistor is installed on the head relay PCB on the back of the head holder to detect the internal unit temperature.

2.3.2.4 Printhead**2.3.2.4.1 Structure of Printhead**

A printhead incorporates six nozzle arrays. Each nozzle can be controlled individually so that a six-color discharge action can be performed by a single printhead.

a) Nozzle arrays

A total of 2560 nozzles are arranged in a two-column staggered pattern.

In each column, 1280 nozzles are arranged in a staggered pattern at intervals of 600 dpi, forming a 2560-nozzle array arranged at intervals of 1200 dpi.

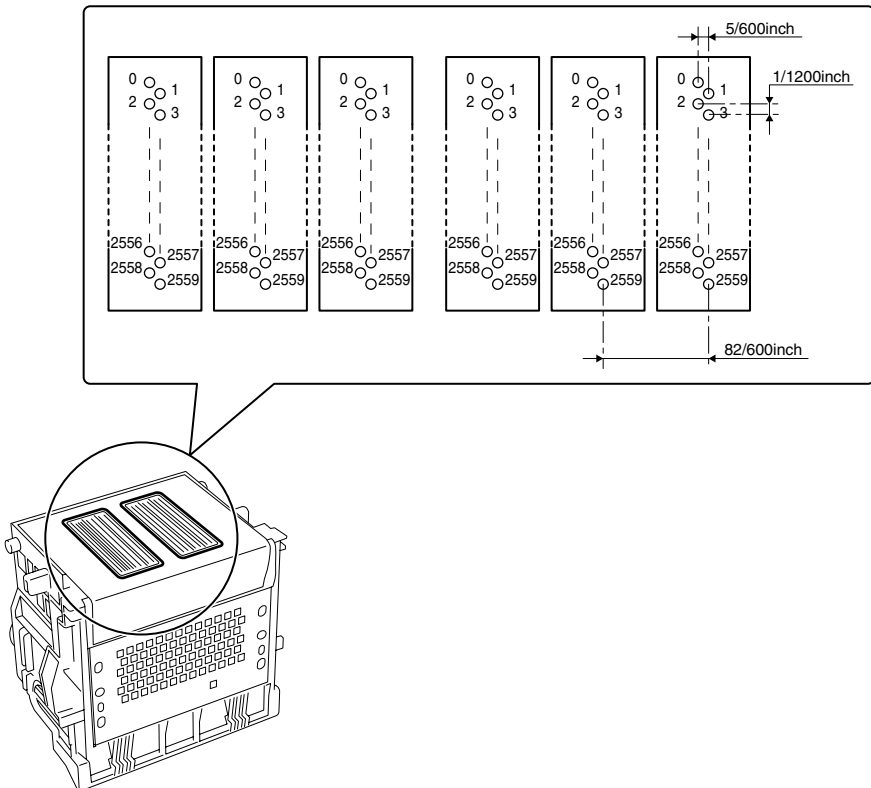

b) Nozzle structure

Ink supplied from the ink tank is filtered by a mesh ink filter, and the supplied to the nozzles. Ink is supplied from the shared ink chamber to the nozzles. When the head driving current is applied to the nozzle heater, ink boils and form bubbles so that ink droplets are discharged from the nozzles.

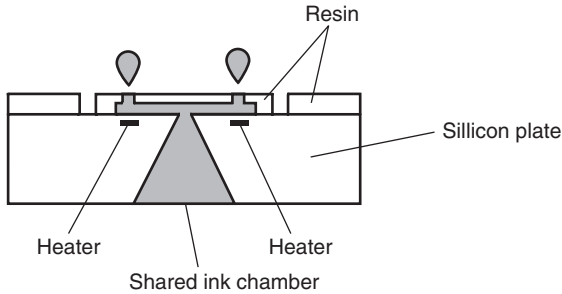

F-2-14

2.3.2.5 Purge Unit

2.3.2.5.1 Functions of Purge Unit

To maintain high print quality, the purge unit performs maintenance of the nozzles o the printhead. The purge unit supports a capping function, cleaning function, and ink supply function.

a) Capping function

The capping function presses the cap of the purge unit against the face plate on the nozzle section of the printhead to prevent nozzle drying and dust adhesion.

Capping is performed when printing is complete, at the start of the suction operation, and when switching to the standby state due to an error.

The capping function also establishes the ink passage between the printhead and purge unit.

b) Cleaning function

The cleaning function restores the printhead to the state where ink can be easily discharged from nozzles. This function includes the following three types of operations.

- Wiping operation

This operation is performed to remove paper fibers and dried ink from to the face plate.

- Pumping operation

This operation is performed to remove ink from the nozzles and fill the nozzles with fresh ink.

- Maintenance jet operation

This operation is performed to spray ink from the nozzles to the cap, borderless ink jet tray, an paper to remove bubbles in the nozzles and dust and other foreign particles.

c) Ink supply function

The suction pump of the purge unit operates together with the ink supply valve to supply ink to the printhead during the initial filling and ink level adjustment.

Details of the cleaning function are shown in the table below.

Cleaning mode	Name of Service mode or PRINT INF (Name of Main Menu)	Operation	Description of cleaning
Cleaning 1	CLN-A-1/CLN-M-1 (Head Cleaning A)	Normal cleaning	Removes dried ink from nozzles, thick ink accumulated on the face, and paper particles.
Cleaning 2	CLN-A-2	Ink level adjustment and cleaning	Adjust the ink level in the head by suction, and then performs normal cleaning.
Cleaning 3	CLN-A-3	Initial filling ink	Fills the empty tube (during initial installation) with ink, and then performs normal cleaning.
Cleaning 4	CLN-M-4 (Replace P.head)	Ink drainage for head replacement	Drains ink to replace the head (drains only the ink in the head).
Cleaning 5	CLN-M-5 (Move Printer)	Ink drainage for secondary transport	Drains ink from the head and tube for secondary transport.
Cleaning 6	CLN-A-6/CLN-M-6 (Head Cleaning B)	Normal (strong) cleaning	Performs suction stronger than when adjusting the ink filling amount in the head or normal cleaning to unclog nozzles.
Cleaning 7	CLN-A-7	Aging	Performs idle ejection after replacement of the head.
Cleaning 10	CLN-A-10 (Move Printer)	Ink filling after secondary transport	Fills the empty tube (during installation after secondary transport) with ink, and performs normal cleaning.
Cleaning 11	CLN-A-11	Ink filling after head replacement	Performs normal cleaning after head replacement and ink filling.
Cleaning 15	CLN-A-15	Dot count suction	Performs suction to remove ink adhered to dried nozzles and thick ink accumulated on the face when the dot count reaches the prescribed value.
Cleaning 16	CLN-A-16	Precipitated ink agitation	Performs the agitation (ink supply valve open/close) operation to prevent the ink ingredient from precipitating.
Cleaning 17	CLN-A-17	Cleaning (weak)	Performs cleaning weaker than normal cleaning to unclog nozzles.

Cleaning operation timings are as follows.

Printer status			Cleaning operation	Consumption (typ.)*1	
Standby	168 hours elapsed capped		Cleaning 1 (Normal Cleaning)	1g	
	At least 720 to 960 hours elapsed since the last session of Cleaning 2, 3, 6 or 10 (480 hours after initial installation)		Cleaning 6 (Normal (strong) Cleaning)	5g	
	At initial installation and 96 hours elapsed since the last session of Cleaning 16		Cleaning 16 (Precipitated ink agitation)	-	
	1 hour elapsed capped with a specified number of dots discharged per chip completed after last wiping		Wiping + Idle ejection	0.013g	
Power-on	At initial installation		Cleaning 3 (initial filling ink)	15g	
	Both heads and inks available	The print operation has completed.	168 to 720 hours elapsed capped	Cleaning 1 (Normal Cleaning)	1g
			At least 720 to 960 hours elapsed since the last session of Cleaning 2, 3, 6 or 10 (360 to 480 hours after initial installation)	Cleaning 6 (Normal (strong) Cleaning)	5g
			At least 960 to 2160 hours elapsed since the last session of Cleaning 2, 3, 6 or 10 (480 hours after initial installation)	Cleaning 2 (Ink level adjustment and cleaning)	10g
			At least 96 hours elapsed since the last session of Cleaning 16	Cleaning 16 (Precipitated ink agitation)	-
			At least 1 hour elapsed capped with a specified number of dots discharged per chip completed after last wiping	Wiping + Idle ejection	0.013g
			Print operation aborted (uncapped) and CR error occurring	Up to 72 hours elapsed after an abort	Cleaning 1 (Normal Cleaning)
		Over 72 hours elapsed after an abort	Cleaning 6 (Normal (strong) Cleaning)	5g	
		Print operation aborted (uncapped) and no CR error occurring	Cleaning 11 (ink filling after head replacement)	10g	
	No heads are available		Cleaning 10 (ink filling on secondary transport)	15g	
Power off	Specified number of dots discharged per chip completed since the last session of wiping		Wiping + Idle ejection	0.013g	
Before the start of printing	Less than 168 hours elapsed capped		Idle ejection	0.013g	
	At least 168 hours elapsed capped		Cleaning 1 (Normal Cleaning)	1g	
	Before printing in the wake of an error occurrence		Cleaning 1 (Normal Cleaning)	1g	
Printing	Before scanning while printing		Idle ejection (+Wiping)	-(0.013g)	

Printer status		Cleaning operation	Consumption (typ.)*1
After the end of printing	A specified number of dots (color) discharged per chip since the last session of Cleaning 2, 3, 6 or 1	Cleaning 6 (Normal (strong) Cleaning)	5g
	A specified number of dots discharged per chip after the last session of wiping	Wiping + Idle ejection	0.013g
	3 minutes elapsed since the last session of capping	Wiping + Idle ejection	0.013g
	Total 2 hours elapsed uncapped since the last session of Cleaning 1, 2, 3, 6 or 10	Cleaning 1 (Normal Cleaning)	1g
When the Head Cleaning menu choice is executed	Manual Cleaning (Head Cleaning A)	Cleaning 1 (Normal Cleaning)	1g
	Manual cleaning (Head cleaning B)	Cleaning 6 (Normal (strong) Cleaning)	5g
When the Replace Print Head menu choice is executed	After head replacement	Cleaning 2 (ink level adjustment and cleaning) + Cleaning 4 (ink drainage for head replacement)	10g
When the Move Printer menu choice is executed	After the Move Printer menu choice is executed	Cleaning 5 (ink drainage for secondary transport)	10g
	After power-on at secondary installation	After power-on at secondary installation	15g

*1: Quantities of ink consumption by nozzle train

2.3.2.5.2 Structure of Purge Unit

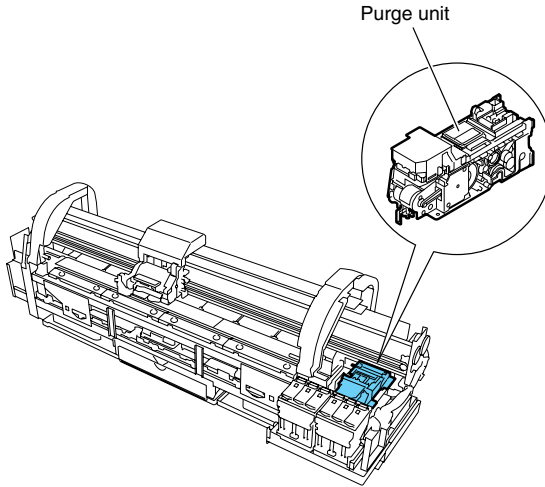

F-2-15

a) Caps

The caps cap the nozzle assembly in the printhead during cleaning. The part of the caps that comes into contact with the face plate of the nozzle assembly is made of rubber. Two caps are in position to meet the printhead mounted on the printhead (six trains of nozzles).

These caps cap the nozzle assembly to suck inks from the printhead by means of the suction pump. The caps are elevated by the cap cam that is driven by the purge motor when the carriage moves to the home position, capping the nozzle assembly to protect it.

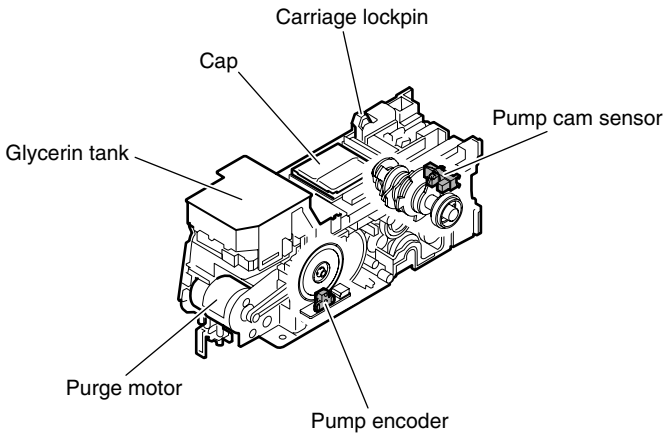

F-2-16

b) Wipers

The wipers are driven by the purge motor to wipe the face of the printhead.

A pair of two wiper blades are installed to ensure wiping performance.

The wiping operation operates on a slide wiping basis, sliding the wiper blades via wiper cams through the rotation (normal) of the purge motor. Wiping is executed by the wiper blades moving at a constant speed to the front of the printer after the end of a print or suction operation.

A wiper blade set perpendicularly to the head wipes the entire face of the printhead, followed by a narrower blade wiping the nozzle assembly.

The wiper blades are cleaned after wiping before they are replaced at the wiping position to maintain wiping performance.

Wiper blade cleaning is carried out by scraping off the inks that have been wipe off from the head with the ink scraper. The wiper blade is subjected to wet wiping, whereby it is pressed against an absorber impregnated with glycerin for added wiping removal performance. The quantity of glycerin used (tank capacity: 50 mL) is managed by counting the number of times the wiper blade has been pressed against the absorber. When this count falls to equal any of the following values, either a replacement warning (continued print available) or replacement required indication (service call error) is issued:

T-2-4

Advance notice of replacement	47,500times
Service call	50,000times

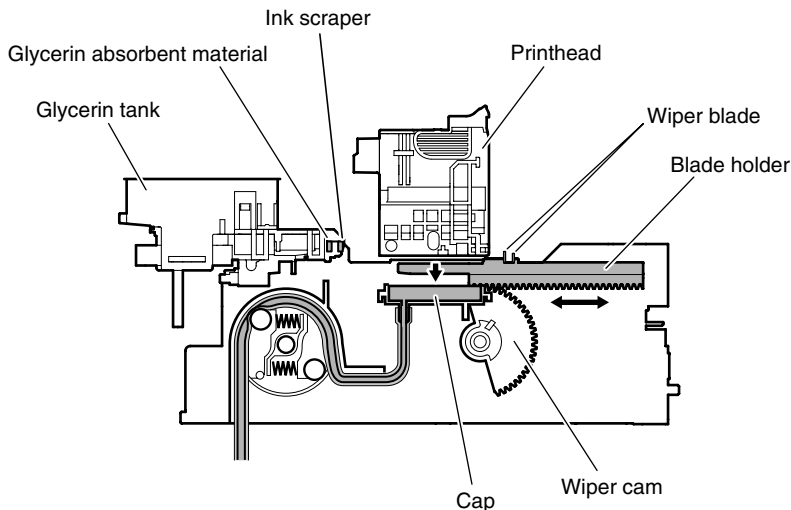

F-2-17

c) Pump

The pump (suction pump) is a tube pump that pressurizes the ink tubes with rotating rollers to generate a negative pressure for sucking inks.

A single tube is sequentially pressurized by a pair of rotating rollers to control the level of ink suction. The timing at which the rotating rollers rotate is detected by the pump cam sensor, with the distance of rotation being controlled by the driving of the purge motor.

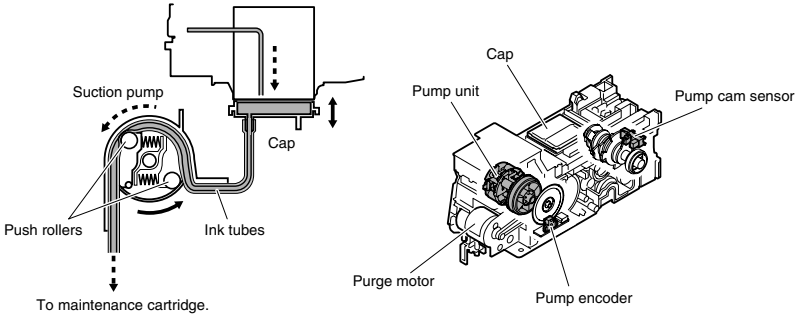

F-2-18

2.3.2.6 Maintenance Cartridge

2.3.2.6.1 Maintenance Cartridge

a) Maintenance cartridge

The maintenance cartridge holds about 1000 mL of used inks (about 867 g: including the evaporation of moisture from the used inks).

b) Used maintenance cartridge ink detection

Used maintenance cartridge ink detection is monitored with regard to a dot count.

When the used ink reaches 80% of the cartridge capacity, the warning message "Maintenance C Space Check" is displayed to tell that the maintenance cartridge is nearly full.

Further use of the maintenance cartridge will cause the appearance of the message "Replace Maintenance Cartridge" to report that the maintenance cartridge is full.

When this error is displayed, the printer assumes that the used ink tank is full, shutting down its operation even while it is printing until the maintenance cartridge is replaced.

The maintenance cartridge houses EEPROM, so that engine firmware can control the status of the maintenance cartridge by writing to and reading from the EEPROM content.

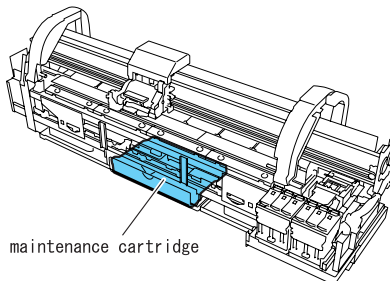

F-2-19

2.3.2.7 Air Flow

2.3.2.7.1 Air flow

This printer is furnished with two fans: a mist fan, which collects ink mist, and a platen fan, which allows paper to be adsorbed on the plate, and a platen fan.

Ink mist floating during printing or bouncing back from the paper is collected in the maintenance cartridge by airflow in the printer.

Airflow fans located on both sides of the printer, coupled with the suction fan in the middle of the printer, create airflow to carry the ink mist to the mist suction port.

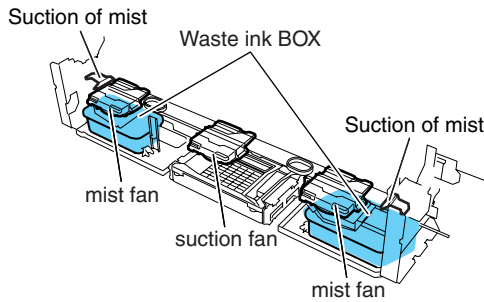

F-2-20

2.3.3 Paper Path

2.3.3.1 Outline

2.3.3.1.1 Overview of Paper Path

The key components of the paper passage consist of a feed roller assembly, a pinch roller drive that locks and releases the pinch roller and sensors that detect the feed status of paper. It feeds paper in trays, conveys and delivers paper.

Paper passage schematic diagram

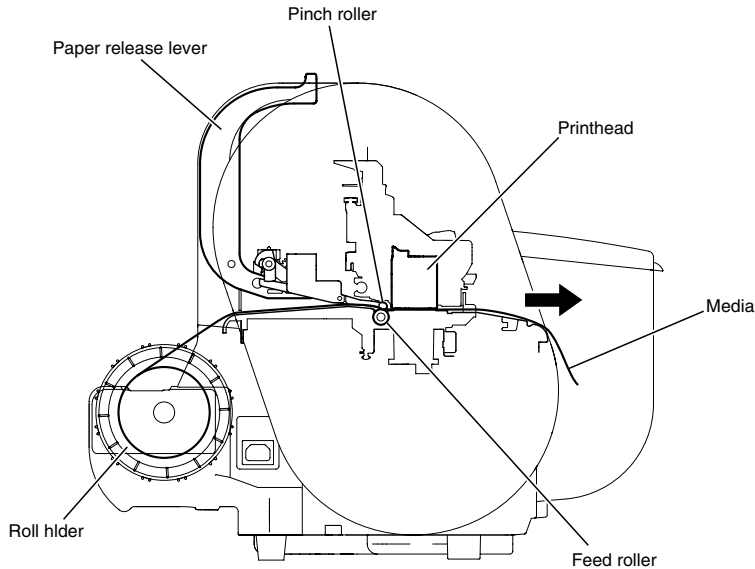

F-2-21

Basic operation of the paper loading sequence

- 1) Light intensity
- 2) Detection of leading edge of media
- 3) Paper width detection sensor
Detects the left and right edges of paper.
- 4) Barcode read
*This function is operable only if the remaining roll media detection sensor is turned on.
- 5) Detection of leading skew of media.
- 6) Detection of leading right edge of media.
- 7) Detection of precut
*When "precut" is only an automatic cutting, it does.
- 8) Precut of media
*In the following cases, the form point is cut.
 - a. When "Up-to-date precut" is a compulsion cutting.
 - b. When necessary having of cutting is judged from an automatic cutting, "Up-to-date precut" .
 - c. When "Roll paper remainder amount detection" is on, and the bar code is detected (Compulsorily cut it regardless of the setting of "Up-to-date precut").
- 9) Detection of leading edge of media.

Basic operations of the cut media loading sequence

- 1) Paper trailing edge detection sensor
- 2) Light intensity
- 3) Detection of paper width
- 4) Detection of skewed movement of paper

MEMO:

When offline, press the [▼] key to discharge the media and the [▲] key to rewind the media.

2.3.3.2 Paper Path

2.3.3.2.1 Structure of Feed Roller Unit

a) Feed roller assembly

The feed roller assembly consists mainly of a feed roller that is driven by the feed motor, a pinch roller unit that follows up the motion of the feed roller and so on.

Paper is fed horizontally under the printhead on the carriage as it is kept level on the platen to prevent heaving.

b) Sensors

The feed roller assembly includes a feed status detection sensor and paper passage mechanical component status detection sensors.

c) Roll media rewind drive unit

The paper feed unit is provided with a roll media rewind drive to prevent paper from slacking during roll media feed. The rewind drive turns on the roll media rewinding clutch to rewind the roll media.

The roll media rewinding clutch can be turned on only when the roll media is fed during the backward feed. The feed motor rotates the roll holder to rewind the roll media. During the forward feed, the roll media rewinding clutch is held off.

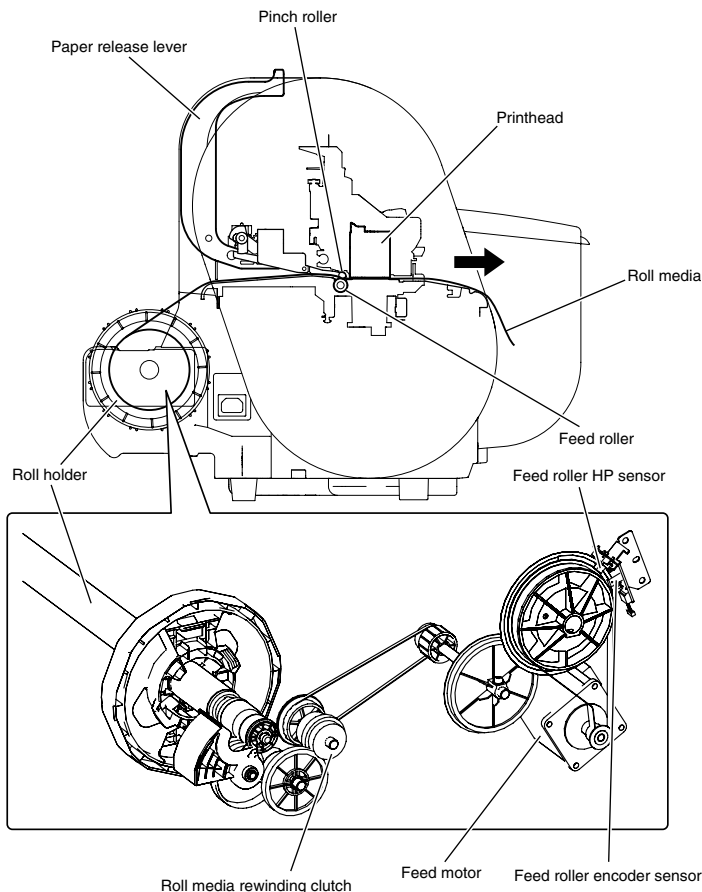

F-2-22

2.3.3.3 Cutter Unit

2.3.3.3.1 Structure of the cutter unit

a) Sheet cutter

When "Autocut: Yes" is selected in the Printer Driver, the cutter unit mounted on the left side of the carriage automatically cuts the roll media. However, the roll media is not cut if it is suppressed by the Printer driver.

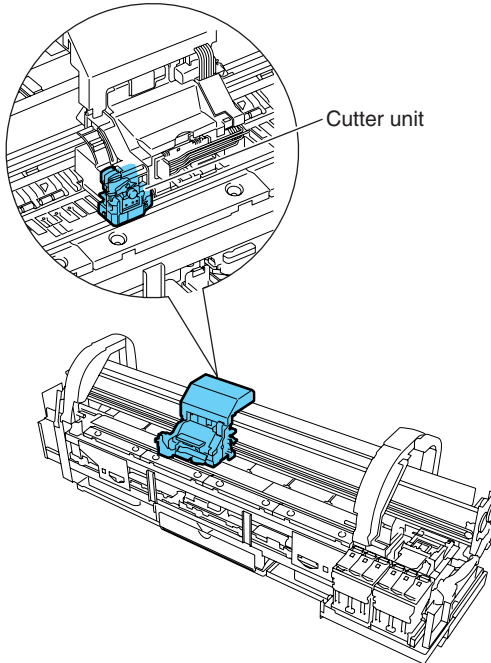

F-2-23

2.4 Printer Electrical System

2.4.1 Outline

2.4.1.1 Overview

The printer electrical system consists of the main controller PCB and power supply PCB which are mounted on the back side of the printer, the carriage relay PCB, the head relay PCB, and printhead which are mounted in the carriage, the operation panel on the right upper cover and other electrical components such as sensors, and motors.

The main controller PCB manages the image data processing and the entire electrical system, and controls relay PCBs and driver functions.

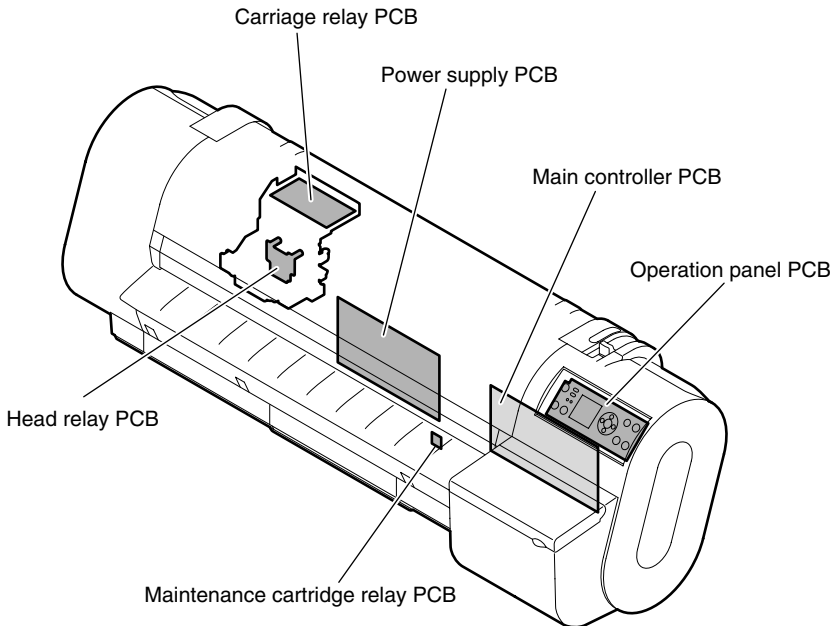

F-2-24

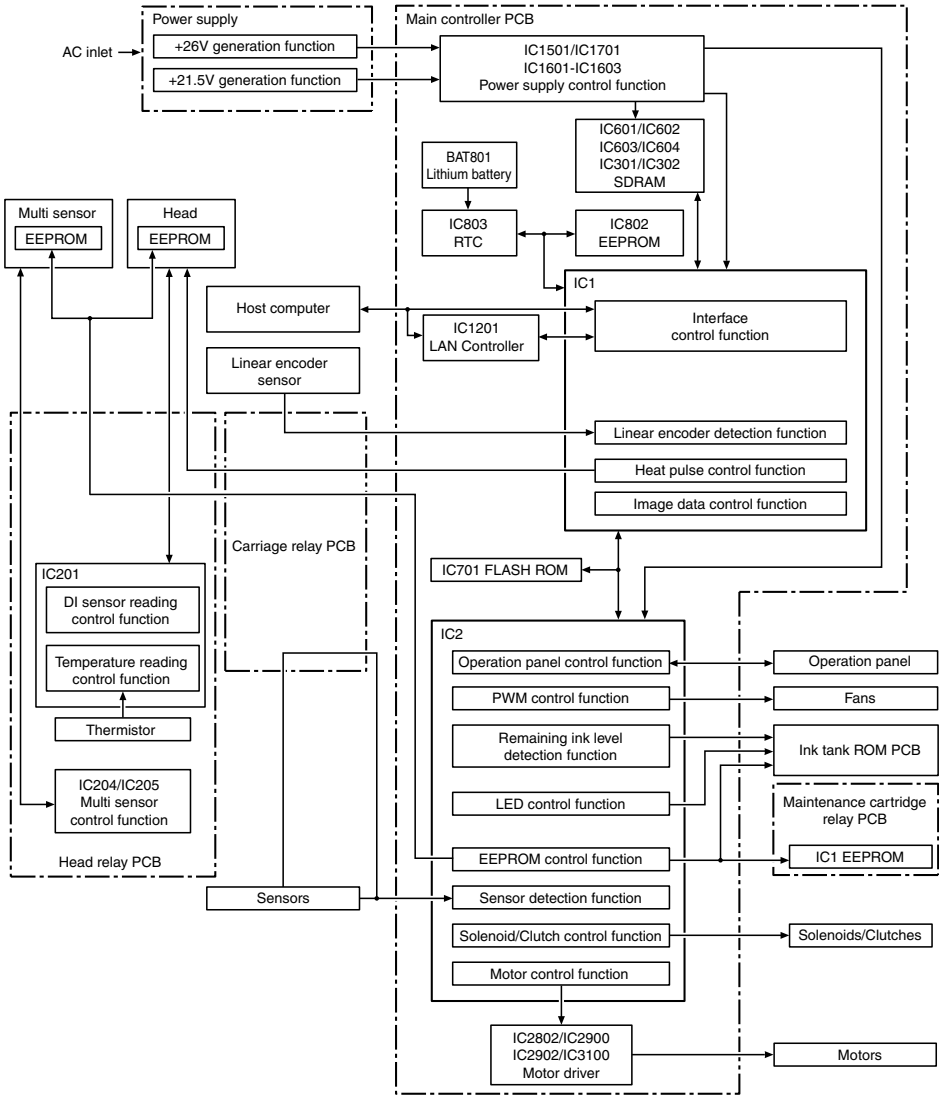

F-2-25

2.4.2 Main Controller

2.4.2.1 Main controller components

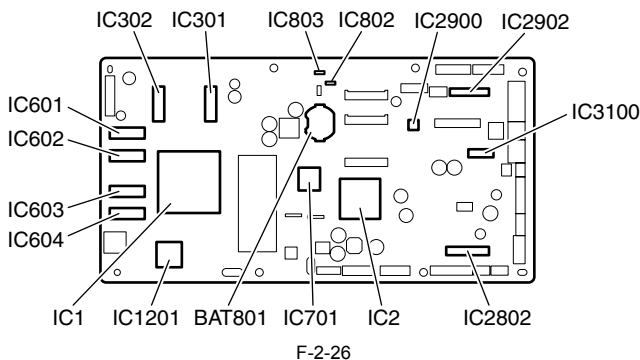

a) ASIC (IC1/IC2)

The ASIC with a 16-bit internal bus is driven in sync with the 66 MHz external clock. It supports the following functions:

Image processing unit

This unit converts the RGB multi-value image data or CMYK multi-value data received from the host computer through the interface connector to the binary image data for the ink colors used.

DMA controller

This controller control DMA transfer of the data transferred through the input interfaces such as the USB and expansion card slot as well as DMA transfer of the data stored in the DIMM.

Image data generation/output function

This function generates image data for color printing from the received image data and the mask pattern (corresponding to print mode) stored in the FLASH ROM, and stored the generated image data in DIMM. It also outputs the generated image data to the carriage PCB.

Interrupt controller

This controller receives and processes internal interrupts and external interrupts from the USB, image processing unit, and expansion card slot.

Timer function

Even when the printer is turned off, the timer function is held on using the RTC(IC803) and lithium battery(BAT801) to assist the cleaning function.

When the power cord is plugged to the outlet, power is supplied to the RTC and therefore the lithium battery power is not consumed.

Heat Enable signal control function

This function uses the pulse width to perform variable control of the time of application of the Heat Enable signal to the nozzle heater board for each printhead nozzle array.

Linear scale count function

This function reads the linear scale when the carriage moves, thus generating the ink discharge timing. It also counts the linear scale timing cycle using the reference clock to measure the carriage moving speed.

Dot count function

This function controls the discharge dots used as the information for Heat Enable signal control, maintenance jet control, cleaning control, and remaining ink level for each nozzle array.

Operation panel control function

This function controls serial communication with the operation panel.

PWM control function

This function controls driving of the suction fan and mist fan as well as the temperature of the printhead.

Remaining ink level detection function

This function detects the remaining level of each color of ink based on the signal received from the hollow needle mounted in the ink tank unit.

LED control function

This function controls the LEDs on the ink tank unit.

I/O port function

This function controls input signals from sensors.

Power ON/OFF control function

This function controls turning on/off of the drive power (26 V and 21.5 V) supplied from the power supply PCB.

Head DI sensor read control function

This function controls read operation by the head DI sensor.

Multi sensor control function

This function controls the LED, adjusts the gain, and controls obtainment of the reading for the multi sensor.

EEPROM control function

This function controls the EEPROMs of individual ink tanks, the maintenance cartridge EEPROM, the EEPROM on the maintenance cartridge relay PCB, and the head EEPROM in addition to the on-board EEPROM.

Motor control function

This function controls the carriage motor, feed motor, valve motor, lift motor and purge motor based on the input signals from sensors.

b) Driver IC (IC3100)

This IC generates a carriage motor control signal based on the control signal from the ASIC.

c) Driver IC (IC2802)

This IC generates feed motor control signal based on the control signal from the ASIC.

d) Driver IC (IC2900)

This IC generates purge motor and valve motor control signals based on the control signal from the ASIC.

e) Driver IC (IC2902)

This IC generates a lift motor control signal based on the control signal from the ASIC.

f) DIMMs (IC301,IC302,IC601,IC602,IC603,IC604)

The DIMM comprising a 128-MB DDR-SDRAM and a 128-MB SDR-SDRAM is connected to the 32-bit data bus to be used as a work area.

During print data reception, it is also used as an image buffer.

It cannot be expanded.

g) FLASH ROM (IC701)

A 16-MB flash ROM is connected to the 8-bit data bus to store the printer control program.

h) EEPROM (IC802)

The 128-KB EEPROM stores various setting values, adjustment values, log data, counter values related to the user/servicing.

MEMO:

After replacement of the main controller PCB, the printer must be started up in the service mode to take over the setting and adjustment values to the new PCB properly (the service mode will be switched to the PCB replacement mode automatically).

2.4.3 Carriage Relay PCB

2.4.3.1 Carriage relay PCB components

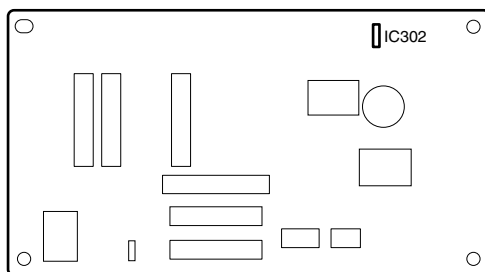

F-2-27

a) Regulator IC (IC302)

This IC generates power for the printhead heater.

2.4.4 Head Relay PCB

2.4.4.1 Head relay PCB components

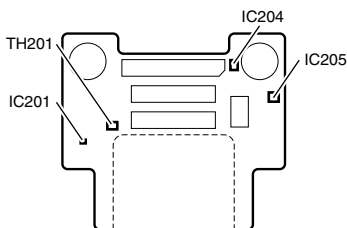

F-2-28

a) Latch IC (IC201)

DI sensor read control function

Obtains reading value of the DI sensor in the printhead and the head rank value for each color and outputs them to the main controller based on the control commands from the main controller.

Environment temperature read control function

Outputs the environment temperature detected by the thermistor on the head relay PCB to the main controller based on the control commands from the main controller.

Relay function of the power to the logic components in the printhead

Supplies the power to the logic components in the printhead based on the control commands from the main controller.

b) Thermistor (TH201)

The environment temperature surrounding the head relay PCB detected by this thermistor is output to the main controller through the carriage relay PCB.

c) Multi sensor control IC (IC204, IC205)

These IC's generates the LED control signals and makes gain adjustment for the multi sensor.

2.4.5 Maintenance Cartridge Relay PCB

2.4.5.1 Maintenance cartridge relay PCB components

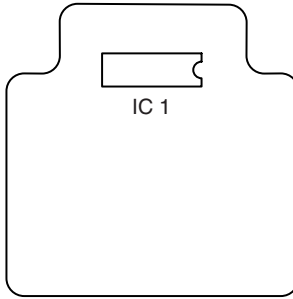

F-2-29

a) EEPROM (IC1)

The 128-KB EEPROM stores all information written in the EEPROM on the main controller PCB.

2.4.6 Power Supply

2.4.6.1 Power supply block diagram

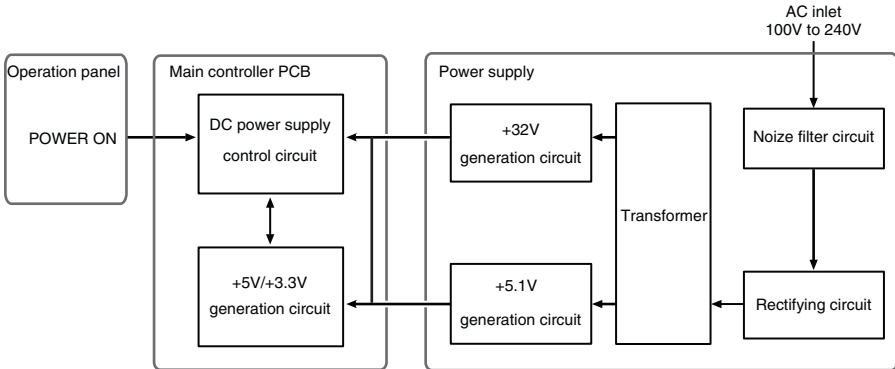

F-2-30

The power supply converts AC voltages ranging from 100 V to 240 V from the AC inlet to DC voltages for driving the ICs, motor, and others.

The voltage generator circuits include the +32 V generation circuit for driving motors, fans, and the +5.1V generator circuit for driving sensors, logic circuits.

When in the power saving mode, the power supply cut outs the +32 V and the +5.1 V.

Power ON/OFF operation is controlled by the main controller PCB. When the upper cover is open, the power supply cut outs only the +32V power to the carriage.

2.5 Detection Functions with Sensors

2.5.1 Sensors for covers

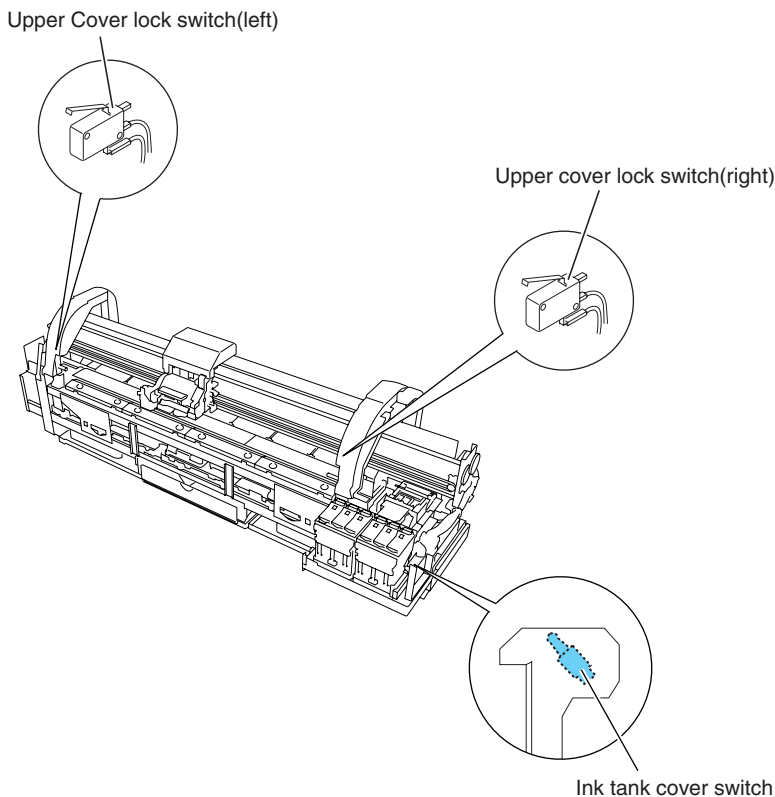

F-2-31

Upper cover lock switch

The micro switch-based Upper cover lock switch detects the open/closed states of the upper cover. When the upper cover closes, the switch is pressed to detect the closed state of the cover.

The printer has one sensor installed on the left and right sides each to prevent one-sided tightening of the upper cover.

Ink tank cover switch

The micro switch-based Ink tank cover switch detects the open/closed states of the ink tank cover. When the ink tank cover closes, the switch is pressed to detect the closed state of the cover.

Memo:

+26.5V is supplied from the power supply unit to drive the carriage motor and the feed motor while the top cover is closed.

2.5.2 Ink passage system

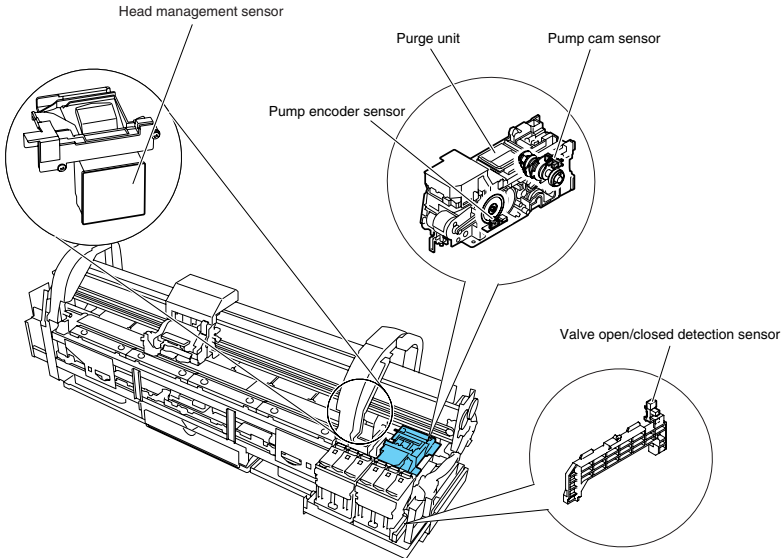

F-2-32

Pump cam sensor

As the cam rotates, it shields the sensor light of the photointerrupter-based pump cam sensor or allows it to be transmitted. The status of the purge unit, such as capped, suction, and wiping, is detected in a combination of the status of detection by the pump cam sensor and the control of purge motor rotation by the pump encoder sensor.

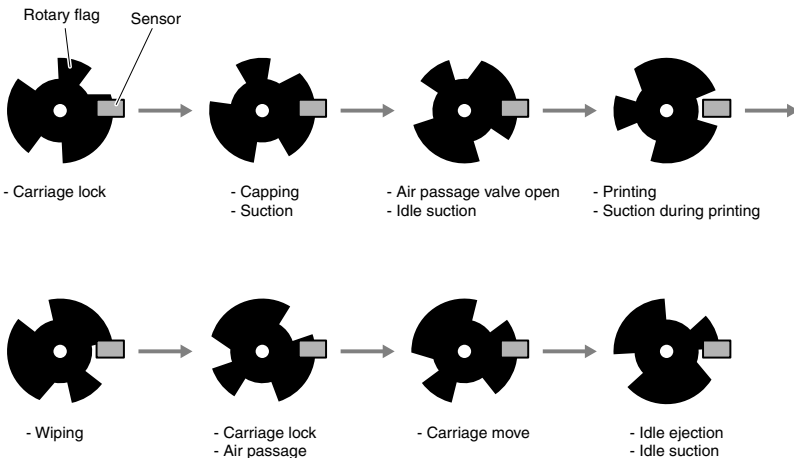

F-2-33

Pump encoder sensor

The photointerrupter-based sensor reads slits in the encoder film of the purge motor and controls the amount of its rotation accordingly.

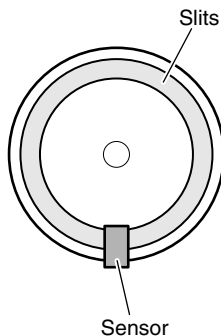

F-2-34

Valve open/closed detection sensor

The photointerrupter-based valve open/closed detection sensor detects the status of the valve cam. The sensor detects that the ink supply valve is open when the sensor light is shielded by a link interlocked with the valve cam.

Ink detection sensor

The ink detection sensor detects the presence or absence of the ink in an ink tank with respect to the status of continuity between two hollow needles.

When the ink level in the tank falls to a point below the wall surrounding the hollow needles in the air passage, continuity with the hollow needle on the ink supply side is disrupted, causing the sensor to detect that ink is out.

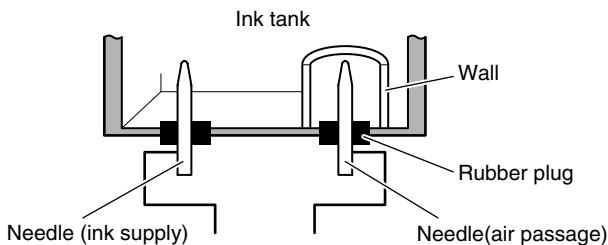

F-2-35

Head management sensor

The photo-transmission-type sensor detects that the printhead is discharging ink.

The carriage moves to and stops at the detection positions for individual nozzle arrays. When the carriage is at a stop, nozzles discharge ink one after another.

The sensor detects each nozzle due to the voltage change caused when ink discharged from the nozzle blocks the sensor light.

Non-discharging nozzle detection is carried out at the following timings:

- After the execution of Cleaning 1, Cleaning 2, Cleaning 3, Cleaning 6 or Cleaning 10
- After the number of copies that has been set by the user menu choice Nozzle Check Frequency have been

printed

If more than a specified number of non-discharging nozzles have been located in one session of non-discharging nozzle detection, the normal cleaning sequence is launched before a second session of non-discharging nozzle detection is conducted. If more than a specified number of non-discharging nozzles are located in the second session of non-discharging nozzle detection, the normal (High) cleaning session is launched before a third session of non-discharging nozzle detection is conducted.

If 30 or more non-discharging nozzles and less than 100 non-discharging nozzles per train are located as a result of the third session of non-discharging nozzle detection, the print operation can resume after the message display as needed. If 100 or more non-discharging nozzles are located, a head replacement prompt message is displayed.

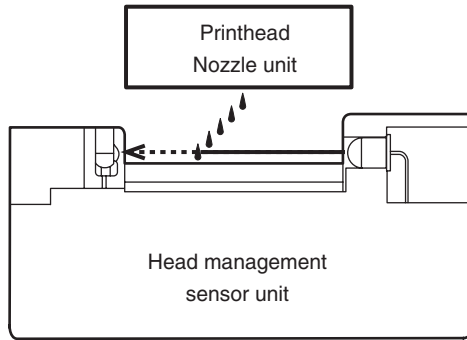

F-2-36

2.5.3 Carriage system

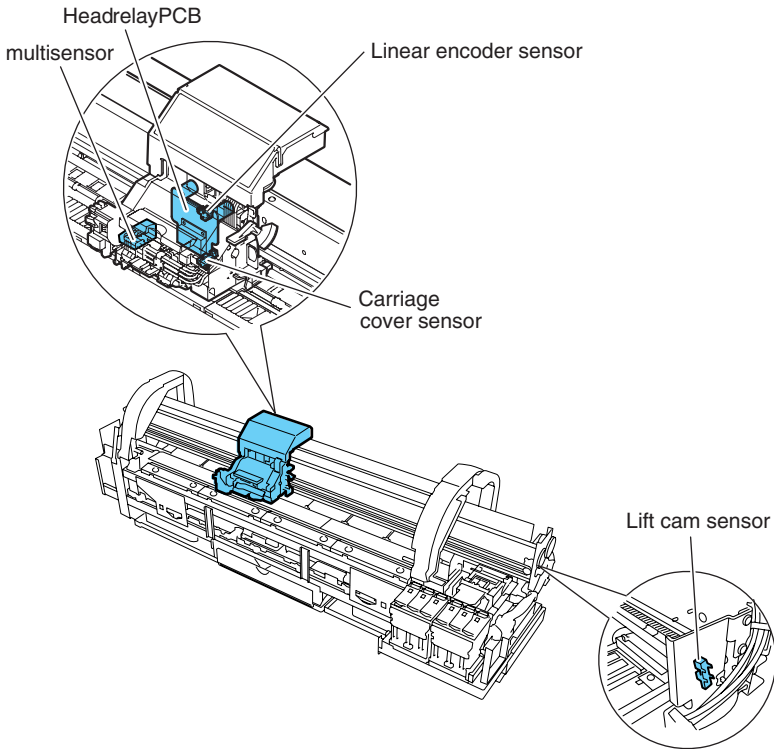

F-2-37

Multisensor

The photoreflexor-based multisensor consists of four LEDs (red, blue, green, infrared) and two light-receiving sensors to detect the leading edges and width of paper and skews in it, and to adjust its registration, head height and calibration.

At head height adjustment, the two light-receiving sensors detect infrared light reflected upon the paper to work out the head height from differences in its measurement.

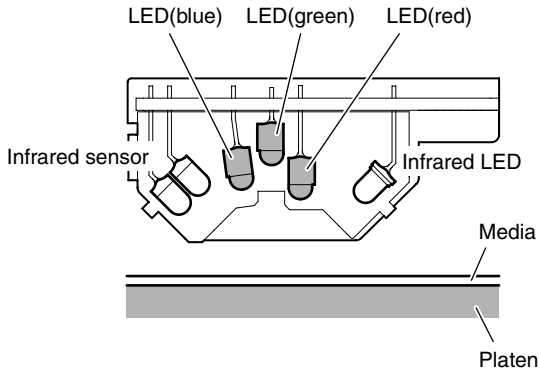

F-2-38



Service mode: After SERVICE MODE > ADJUST > GAP CALIB. has been carried out, pass paper to make sure that it is detected properly.

Carriage cover sensor

The photointerrupter-based carriage cover sensor detects the opening and closing of the carriage sensor. When the carriage cover is closed, the sensor light is shielded by the sensor arm, enabling the sensor to detect that the carriage cover is closed.

Lift cam sensor

A photointerrupter-based sensor. After the sensor light is shielded by the flag, the lift motor is driven by a predetermined number of pulses to regulate the separation between the printhead and platen automatically.

Linear encoder sensor

Mounted on the back of the carriage, the linear encoder detects the position of the carriage from a slit in the linear scale during its movement.

Ambient temperature sensor

The thermostat-based ambient temperature sensor mounted on the head relay PCB detects the ambient temperature to which the carriage is exposed. The resistance of the thermistor that varies as a function of temperature changes in the printer is transmitted the main controller via the carriage relay PCB. The ambient temperature is used to help calibrate the head temperature sensor and detect abnormal ambient temperatures.

Head temperature sensor

The head temperature sensor detects the temperature of the printhead. The printhead temperature is transmitted to the main controller via the carriage relay PCB. The printhead temperature is used to help control the head drive and detect abnormal printhead temperatures.

Printhead contact sensor

The printhead contact sensor detects the status of printhead installation by electrical means.

The sensor detects the status of contact from voltage changes in the flexible cables on the carriage side that come into contact with two terminals of the printhead with remote contact surfaces, the power terminals and GND terminal.

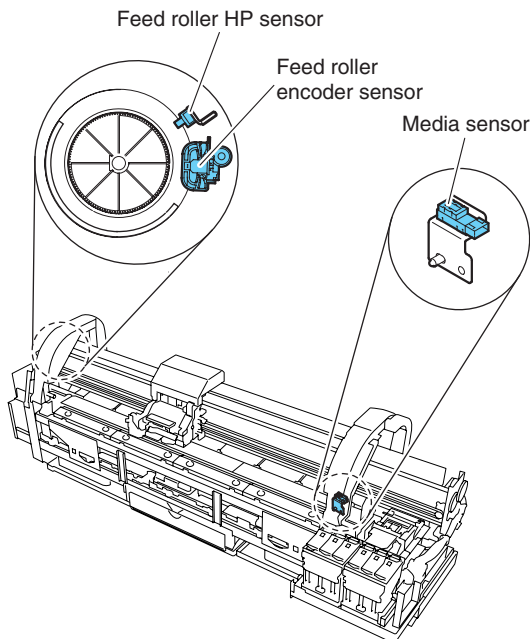
2.5.4 Paper path system

F-2-39

Media sensor

The photoreflector-based media sensor detects the presence or absence of paper on the platen. The sensor detects the presence of paper when it receives sensor light reflected upon the paper.

Feed roller HP sensor

The feed roller HP sensor sets an LF eccentricity correction home position by detecting transitions from black (shielded) to white (transmitted), or a reference, in the scale in the code wheel.

Feed roller encoder sensor

The feed roller encoder sensor detects the carriage position from slits in the feed roller pulley as it is driven.

Chapter 3 INSTALLATION

3.1 Transporting the Printer

3.1.1 Transporting the Printer

3.1.1.1 Transporting the Printer

Do not remove the printhead once they are installed, as this may cause the nozzles to dry out or accumulate foreign matter. Also the head must be capped and stay in the carriage while transporting the printer. In spite of this precaution, shocks incurred during transportation can still damage the print heads. Print the "Nozzle Check" before moving the printer, print the "Nozzle Check" after installing in a new location, and compare the two printouts. If any deterioration is evident in the output quality, replace the printhead with new ones.

This subsection describes how to transport the printer.

When moving the printer to another place on the same floor of the building, move it slowly so that it does not receive any shocks. Follow the steps shown in "1. Moving the printer on the same floor".

When moving it elsewhere, follow the steps shown in "2. How to transport the printer to a different floor".



Always hold the carrying handles at the bottom of the printer when lifting and moving the printer. Holding the printer by its cover can deform the cover.

Moving or transport operations where the printer needs to be temporarily tilted or stood upright must be performed by service personnel.

1. Moving the printer on the same floor

- 1) Turn off the [Power] button, and check that the heads are capped.
 - 2) Open the upper cover, and mount the belt stopper.
-



When mounting the belt stopper, be careful not to move the carriage by applying too much pressure. If the carriage moves when the heads are capped, the rubber part of the cap may touch the nozzles on the heads and damage the printhead.

- 3) Close the upper cover.
 - 4) Remove the roll holder from the roll holder slot.
 - 5) Remove the interface cable and power cord from the printer.
 - 6) If the printer is mounted on a stand, unlock the casters on the stand.
 - 7) Hold the printer carrying handle at the bottom, and then slowly move the printer.
-



If the printer is subjected to strong vibrations when it is moved, it can cause ink leakage or damage to the printhead. Be sure to move the printer slowly and carefully.

2. How to transport the printer to a different floor

Follow the steps shown in a) When the printer is operating properly. When the printer is not operating properly due to breakdown or a power-supply problem, follow the steps shown in b) When the printer is not operating properly.

a) When the printer is operating properly



To prevent the waste ink from leaking, drain the ink, and then remove the maintenance cartridge. Package the removed maintenance cartridge so that the waste ink does not leak from it.

- 1) Turn on the [Power] button on the printer.
 - 2) Remove the roll holder from the roll holder slot.
 - 3) Enter the Main menu, and then select "Maintenance" > "Move Printer". Follow the instructions in the messages, and remove all of the ink tanks.
- Put the removed ink tanks in the plastic bag with the ink supply part upward and close the opening.
It takes about 4 minutes to complete the "Move Printer" operation.
-



- "Move Printer" cannot be selected when "MTCart Full Soon" is displayed.
In this case, replace the maintenance cartridge first.
- Never disconnect the power cord, or open the covers while the "Move Printer" operation is in progress since this can cancel the operation. If the "Move Printer" operation is canceled while in progress, the printer will remain in offline mode, and it will not switch to online mode. "Ink Filling" is performed when the power is turned back on after canceling so repeat "Move Printer" from the beginning.

- 4) Once the "Move Printer" operation is completed, turn off the [Power] button.
 - 5) Open the upper cover, check that the heads are capped, and then use the belt stopper to secure the carriage in place. (PRODUCT DESCRIPTION > Safety and Precautions > Other Precautions > Handling the Printer > Fixing the carriage.)
-



When mounting the belt stopper, be careful not to move the carriage by applying too much pressure. If the carriage moves when the heads are capped, the rubber part of the cap may touch the nozzles on the heads and damage the printhead.

- 6) Close the upper cover.
 - 7) Disconnect the interface cable and power cord from the printer.
 - 8) Wait 15 minutes after "Move Printer" and then remove the maintenance cartridge and package them so that used ink does not leak from them.
-



Check that used ink is no longer leaking after removing the maintenance cartridge. If it is leaking, install the maintenance cartridge and wait until leaking stops.

- 9) Attach the cushioning materials and tape.
 - 10) If the printer is mounted on a stand, remove the printer from the stand.
 - 11) Pack the printer into the packing box, and then put the roll media, ink tank, and optional devices in another packing box for moving.
- Use the original packing material for the printer and optional devices. If it is not available, pack them with a sufficient amount of cushioning materials.

b) When the printer is not operating properly

- 1) Make sure that the printer is turned off.
- 2) Disconnect the interface cable and power cord from the printer.
- 3) Remove the roll holder from the roll holder slot.
- 4) While referring to DISASSEMBLY/REASSEMBLY > Draining the Ink > Manual Ink Drainage, drain the ink from the printer.
- 5) While referring to INSTALLATION > Transporting the Printer > Transporting the Printer > Manual Capping, perform the capping operation.
- 6) Remove the maintenance cartridge, and then package it so that the waste ink does not leak from it.
- 7) Attach all of the exterior covers
- 8) Open the upper cover, and then use the belt stopper to secure the carriage in place. (Refer to PRODUCT DESCRIPTION > Safety and Precautions > Other Precautions > Handling the Printer > Fixing the carriage.)
- 9) Close the upper cover.
- 10) Attach the cushioning materials and tape.
- 11) If the printer is mounted on a stand, remove the printer from the stand.
- 12) Use the original packing material for the printer and optional devices. If it is not available, pack them with a sufficient amount of cushioning materials.

3. Manual capping

When transporting the printer, cap the Printhead to protect the nozzles from drying out and to keep them clean. Follow the procedures described below:

- 1) While referring to DISASSEMBLY/REASSEMBLY > Points to Note on Disassembly and Reassembly > Opening the caps and releasing the carriage lock pins, open all of the caps.
- 2) Move the carriage to the home position.
- 3) While referring to DISASSEMBLY/REASSEMBLY > Points to Note on Disassembly and Reassembly > Opening the caps and releasing the carriage lock pins.



Manual capping is an emergency measure when the printer does not operate. Manual capping can damage the printhead.

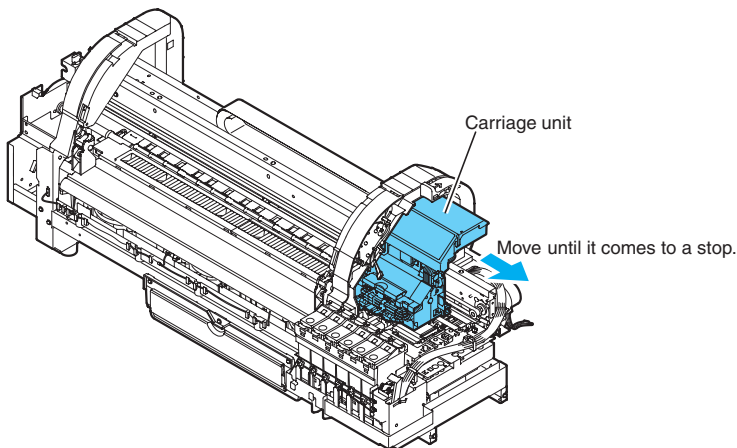

F-3-1

3.1.2 Reinstalling the Printer

3.1.2.1 Reinstalling the Printer

1. Installing the printer on the same floor

If ink has not been drained from the printer when moving it to another place on the same floor, then an operation check (Test Print) needs to be performed after the printer is moved to a new location.

2. Installing the printer on a different floor

If ink has been drained when transporting the printer to a different floor, follow the installation procedure below. It is nearly identical to the procedure when installing for the first time.

- 1) Unpack the printer, and mount the printer on a stand if a stand is included.
- 2) Remove the cushioning materials and tape.
- 3) Reattach the maintenance cartridge.
- 4) Remove the belt stopper.
- 5) Connect the power cord.
- 6) Turn on the power and following the instruction in the message to install the ink tank. The ink is filled.
- 7) Load the media, and perform the operation check.

Contents

3.1 Transporting the Printer	3-1
3.1.1 Transporting the Printer	3-1
3.1.1.1 Transporting the Printer	3-1
3.1.2 Reinstalling the Printer	3-4
3.1.2.1 Reinstalling the Printer	3-4

Chapter 4 DISASSEMBLY/REASSEMBLY

Contents

4.1 Service Parts.....	4-1
4.1.1 Service Parts.....	4-1
4.2 Disassembly/Reassembly.....	4-1
4.2.1 Disassembly/Reassembly.....	4-1
4.3 Points to Note on Disassembly and Reassembly.....	4-3
4.3.1 Note on locations prohibited from disassembly.....	4-3
4.3.2 Moving the carriage manually.....	4-3
4.3.3 Units requiring draining of ink.....	4-3
4.3.4 External Covers.....	4-4
4.3.5 Waste Ink Box.....	4-11
4.3.6 Driving Unit.....	4-12
4.3.7 Ink Tube Unit.....	4-13
4.3.8 Carriage Unit.....	4-16
4.3.9 Feeder Unit.....	4-21
4.3.10 Purge Unit.....	4-22
4.3.11 Ink Tank Unit.....	4-23
4.3.12 Head Management Sensor.....	4-25
4.3.13 Multi Sensor.....	4-26
4.3.14 PCBs.....	4-27
4.3.15 Opening the Cap/Moving the Wiper Unit.....	4-28
4.3.16 Opening/Closing the Ink Supply Valve.....	4-29
4.3.17 Draining the Ink.....	4-30
4.4 Applying the Grease.....	4-31
4.4.1 Applying the Grease.....	4-31
4.5 Adjustment and Setup Items.....	4-33
4.5.1 Adjustment Item List.....	4-33
4.5.2 Procedure after Replacing the Feed Roller or Feed Roller Encoder.....	4-33
4.5.3 Procedure after Replacing the Carriage Unit or Multi Sensor.....	4-33
4.5.4 Procedure after Replacing the Head Management Sensor.....	4-34

4.1 Service Parts

4.1.1 Service Parts

The service parts indicated below require careful handling.

1. Keep all packages with the warning not to turn over.

Pay careful attention to all individually packaged service part (carriage unit, purge unit, ink tank unit, and other parts) boxes marked "This side up" and handle appropriately.



F-4-1

4.2 Disassembly/Reassembly

4.2.1 Disassembly/Reassembly

The general disassembly and assembly flows of the major components are shown below.

Symbol Meanings c: Connector, e: E-ring, h: Holder, s: Screw

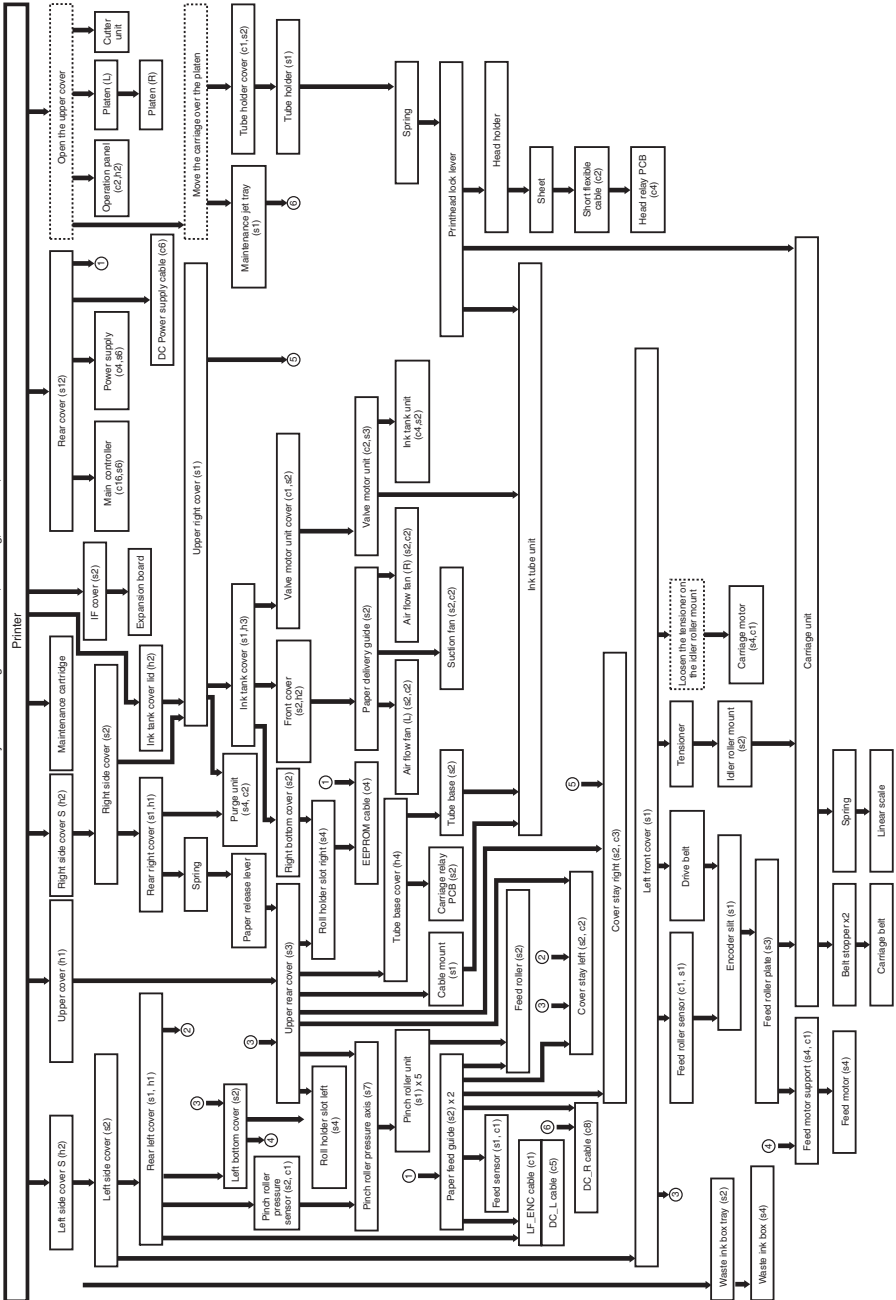

F-4-2

4.3 Points to Note on Disassembly and Reassembly

4.3.1 Note on locations prohibited from disassembly



Assemblies that are prohibited from disassembly and their adjustment outside the factory cannot be conducted are indicated by red screws.

Don't never loosen or remove the red screw, because normal operation and print can't be done if it is loosened or removed.



F-4-3

4.3.2 Moving the carriage manually



Move the carriage as required during disassembly/reassembly to prevent the carriage from contacting the parts to be removed.

The carriage does not move when capped. When uncapping moving the carriage, refer to the procedures in DISASSEMBLY/REASSEMBLY>Points to Note on Disassembly and Reassembly>Opening the Cap/Moving the Wiper Unit.

4.3.3 Units requiring draining of ink

Before disassembling the units in the ink passage mentioned below, drain them of inks completely to prevent their leakage.

For instructions on how to drain units of inks, see Disassembly/Reassembly > Tips on Disassembly/Reassembly > Ink Drainage.

[1] Ink Tube Unit

See Disassembly/Reassembly > Tips on Disassembly/Reassembly > Ink Tube Unit.

[2] Carriage Unit/Head Holder

See Disassembly/Reassembly > Tips on Disassembly/Reassembly > Carriage unit.

[3]Ink Tank Unit

See Disassembly/Reassembly > Tips on Disassembly/Reassembly > Ink Tank Unit.

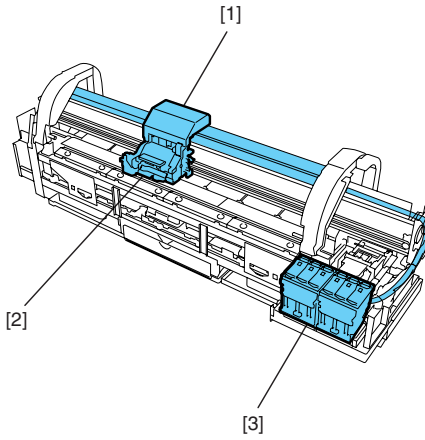

F-4-4

4.3.4 External Covers

a. Upper cover

To detach the upper cover, detach damper cover [1] located on the left and right sides of the back each. Then, fully open the upper cover and slide it to left.

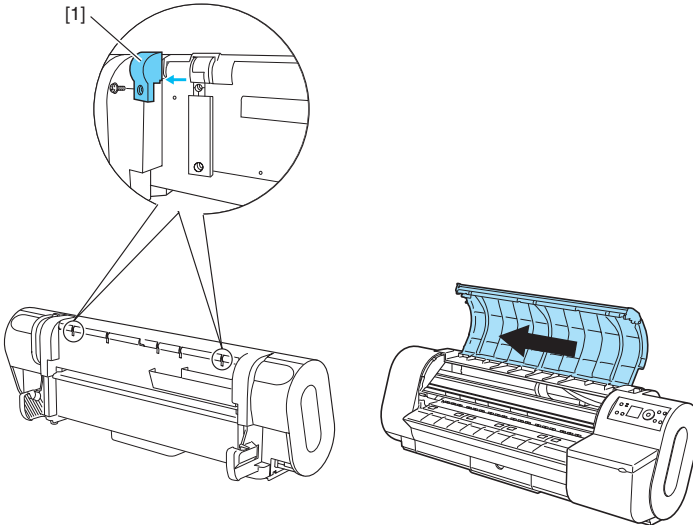

F-4-5



In attaching the upper cover, have the boss on damper [1] located on both sides into slit [2].
If the upper cover is not attached in correct position, it would slam shut without the damper being activated.

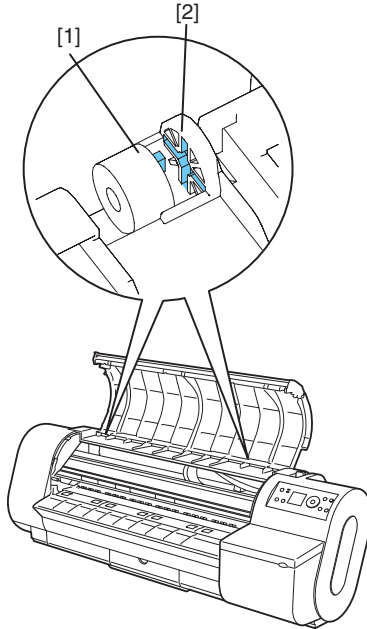

F-4-6

b. Right side and left side covers

To detach a side cover, slide up side cover S [1] in the middle. Unscrew two screws [3] hidden under side cover S [1] and slide downside cover [2] to detach the slide cover.

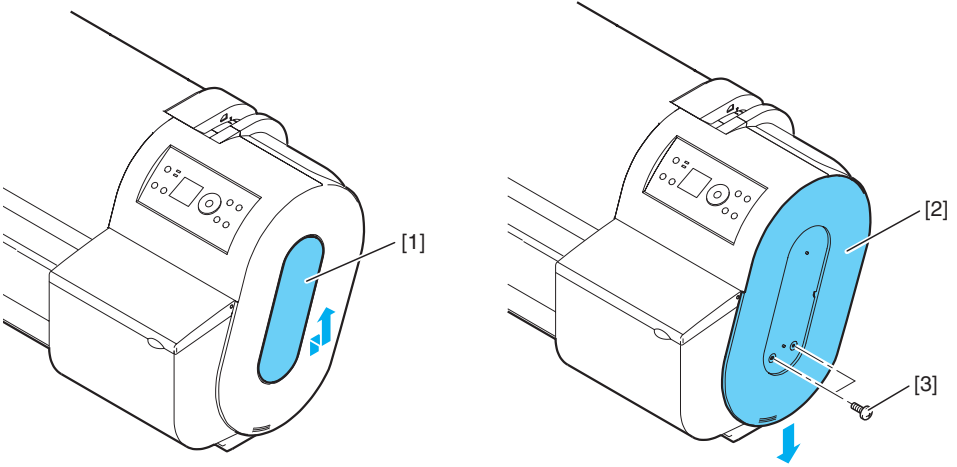

F-4-7

c. Operation panel

To remove the operation panel, first open the top cover, insert your hand into the inside of the right upper cover from the left side and release two lower claws [2] securing operation panel [1] in position. Then, push out operation panel [1] to front to release it from upper three hooks. Then, remove the two connectors [3] from the back of operation panel [1] to which harnesses are attached.

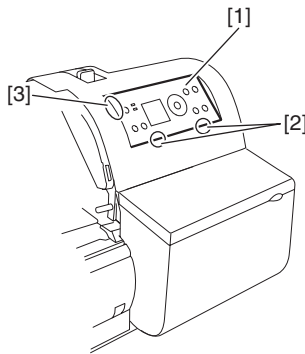

F-4-8

d. Right upper cover

To detach the right upper cover[1], first open the top cover, remove the operation panel, right cover lid and right side cover, and then unscrew the front-panel screws[2]. Next, pull the right side of the right upper cover to front and slide it down out of position by lifting up the upper left edge of the cover.

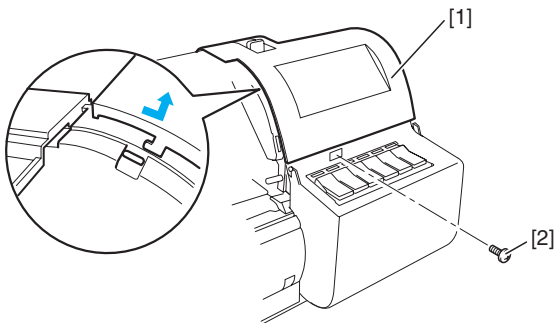

F-4-9



Take maximum care in reinstalling the right upper cover not to interfere with the harnesses connected to the operation panel.

e. Ink tank cover

To detach the ink tank cover[1], remove the right side cover, right upper cover and ink tank cover lid and unscrew the front-panel screws[2]. Next, detach the right cover by lifting it up as a whole.

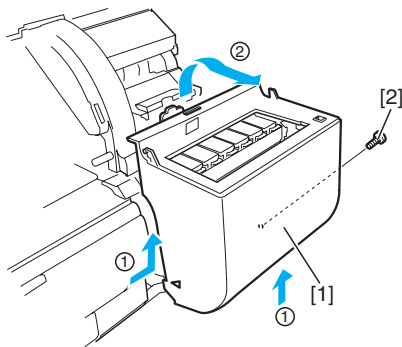

F-4-10

f. Front cover

To detach the front cover[1], the right cover needs to be removed and the maintenance cartridge cover opened beforehand so the front cover can be slid to right to remove.

To do this, unscrew the four front-panel screws[2] and remove two bottom claws[3], and slide the front cover to right. Then, pull out the upper eight hooks to front to detach the front cover.

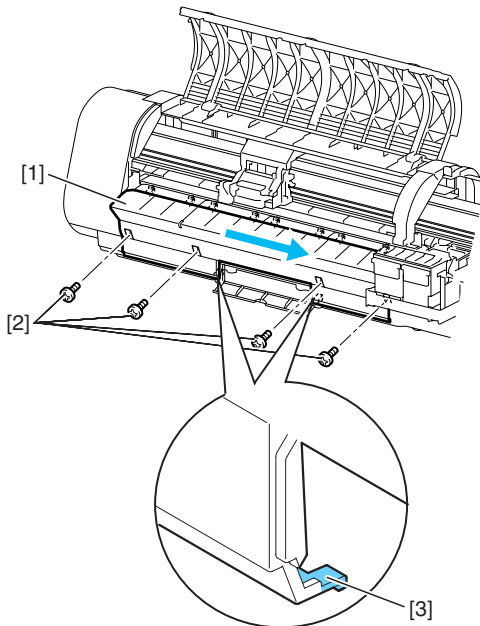

F-4-11

g. Upper rear cover

To detach the upper rear cover, first remove the top cover, the right rear cover and left front cover, left rear cover and paper release lever. Upper rear cover [1] has upper top claw [2] inserted into cover stay [3]. Rotate the upper edge of the upper rear cover about 90 degrees to detach it.

Attach the upper rear cover with claw [2] at its upper edge into cover stay [3] first.

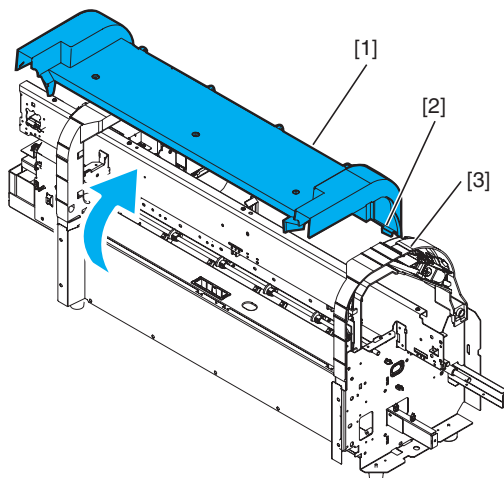

F-4-12

h. Rear cover

To detach rear cover [1], unscrew 12 screws [2] and remove the cover from the bottom side first.

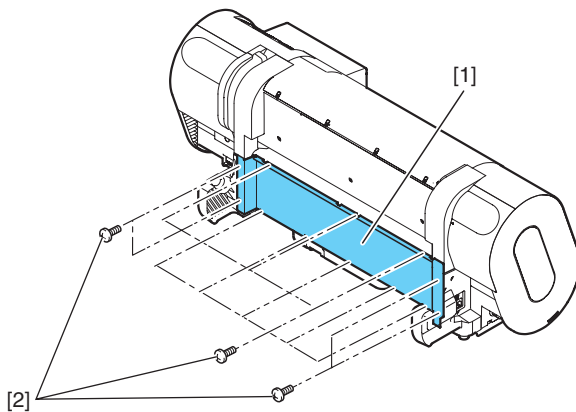

F-4-13

i. Paper release lever

To remove paper release lever [1], do so with the pinch roller pressurized. In assembling paper release lever [1] into position, align the gear of paper release lever [1] with the mark on the receiving gear (phase) [2].

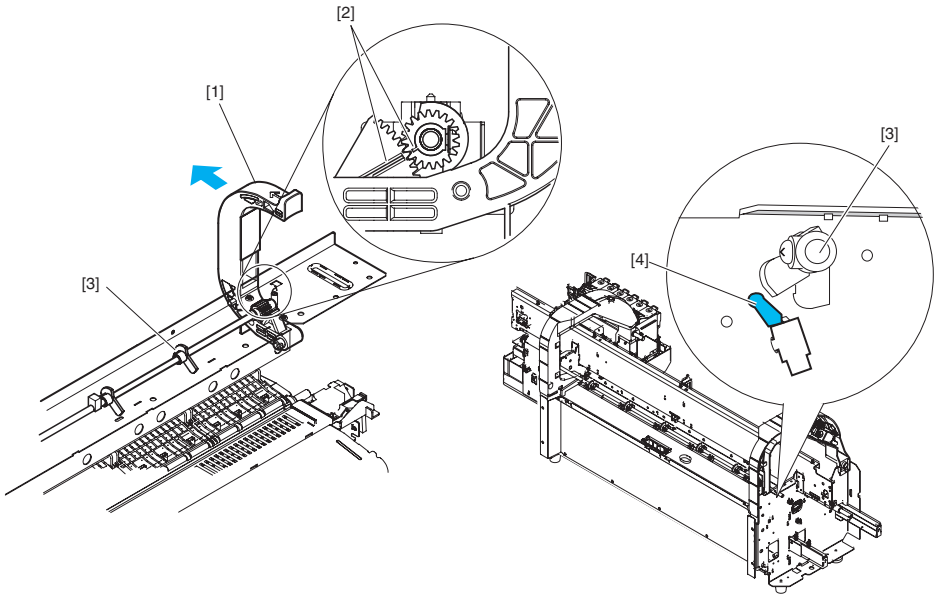

F-4-14



If pinch roller cam [3] has been overrun when paper release lever [1] is installed, remove cam sensor [4] and replace pinch roller cam [3] in original position.

If pinch roller cam [3] is replaced with cam sensor [4] in position, damage to cam sensor [4] could result.

4.3.5 Waste Ink Box

a. Removing the waste ink box

To remove the waste ink box, remove waste ink tray [1] from the back by unscrewing two screws[4]. Then, unscrew four screws[2] to remove waste ink box [3].

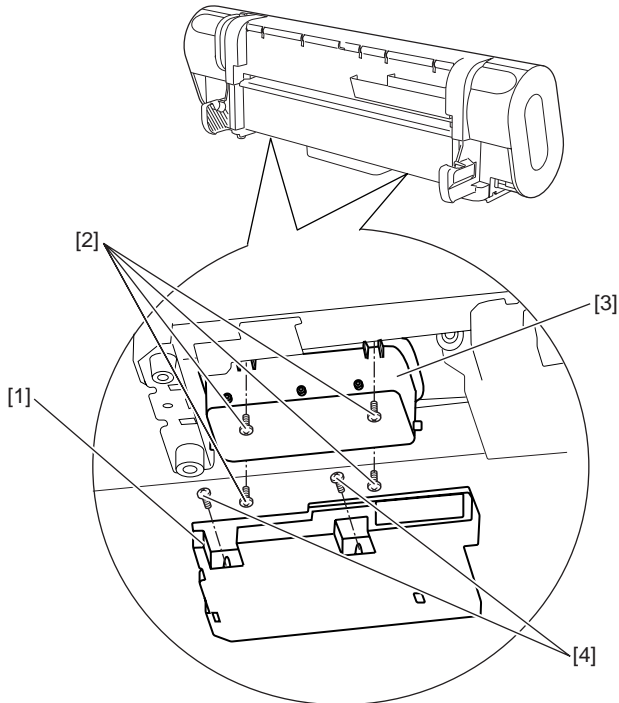

F-4-15

4.3.6 Driving Unit

a. Timing belt (for driving the feed roller)

To assemble the timing belt for driving the feed roller, loosen the tensioner setscrew and establish the tension of the timing belt by adjusting the spring pressure. When the timing belt is assembled back in position, tighten the tension with the setscrew.

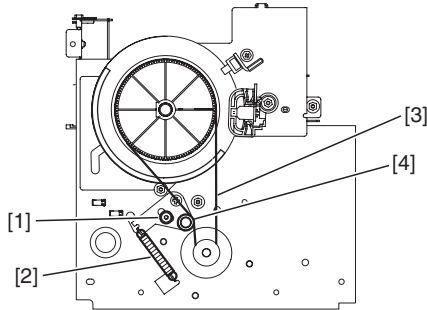

F-4-16

b. Action following the replacement of the feed roller and feed roller encoder

This printer as shipped has the feed roller eccentricity (that is, variations in the rate of paper feed from rotation to rotation) corrected for enhanced media feed accuracy. When the feed roller, feed roller HP sensor or feed roller encoder pertaining to the correction of eccentricity variations has been replaced or disassembled and reassembled, therefore, the feed roller should require adjustment.

Execute service mode under the following conditions:

Service mode SERVICE MODE > ADJUST > PRINT PATTERN > LF TUNING

Media type: Gloss photo paper

Paper size: 36 inches

If adjustment cannot be done properly by selecting "SERVICE MODE > ADJUST > PRINT PATTERN > LF TUNING" (auto adjustment), carry out manual adjustment.

Service mode SERVICE MODE > ADJUST > PRINT PATTERN > LF TUNING2

Media type: Gloss photo paper

Paper size: 36 inches

Check the printed pattern and enter values for adjustment.

4.3.7 Ink Tube Unit

a. Removing the ink tube unit

- (1) Drain the inks of printer. See "Disassembly/Reassembly" > "Points to Note on Disassembly and Reassembly" > "Draining the Ink".
- (2) Turn off the printer and move the carriage to above the platen. See "Disassembly/Reassembly" > "Disassembly/Reassembly" > "Opening the Caps and Moving the Wiper Unit".
- (3) Remove the shaft cleaner and detach the tube holder cover.

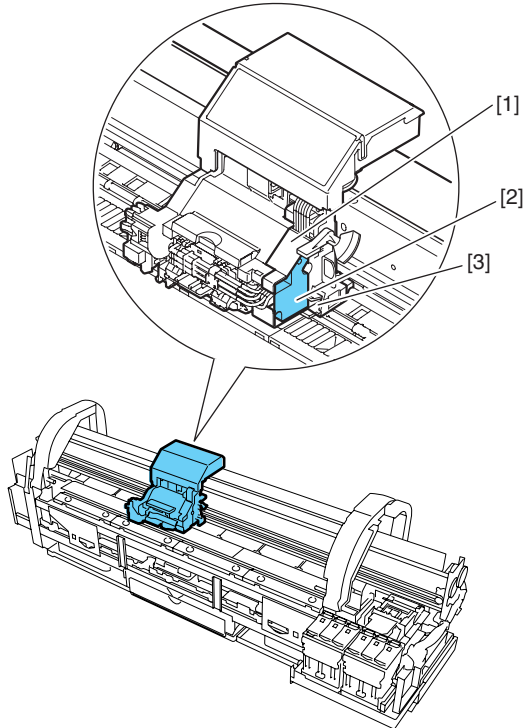

F-4-17

- (4) Disconnect three flexible cables from the main controller.
- (5) Remove the feed guide (right) that encloses the flexible cables extending from the main controller.
- (6) Disconnect all connectors from the carriage relay PCB.
- (7) Disconnect the joint between the ink tube unit and the ink tank unit.

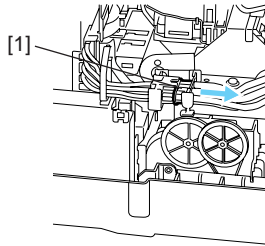

F-4-18

- (8) Remove the printhead.
- (9) Remove printhead fixer lever [1].
- (10) Cover the joint of the ink tube unit in a plastic bag or the like to prevent ink splashing and leakage, and seal the mouth of the bag.

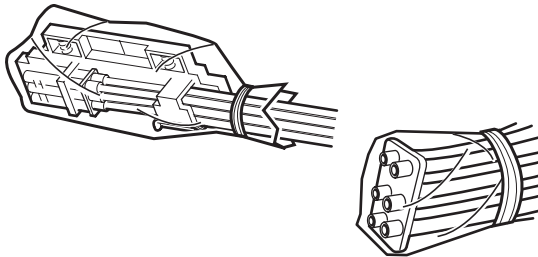

F-4-19

- (11) Release the cable cover from its claw away from the frame.
- (12) Unscrew one screw [2] and remove the cable clamp [1] from the frame.

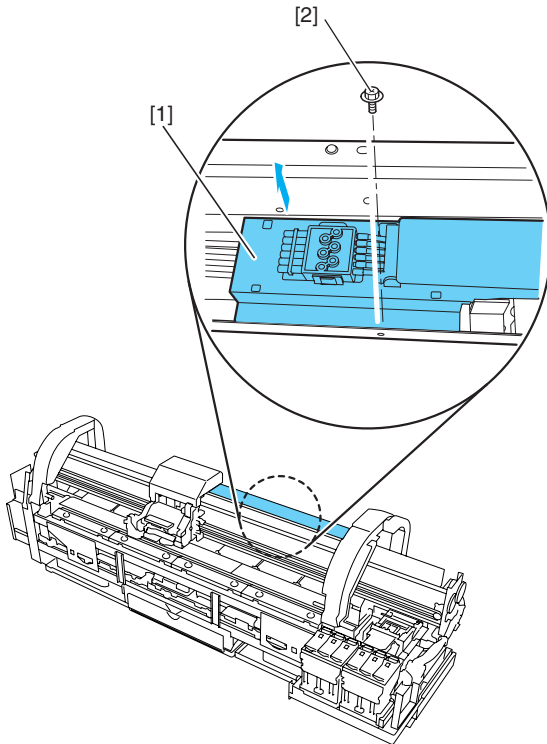

F-4-20

- (13) Release the ink tube unit from the carriage.

b. Reassembling the ink tube unit

When the ink unit has been replaced, turn on the power switch without the printhead and the ink tanks mounted. Then, mount the printhead and ink tanks as directed by message guidance to fill the tanks.

4.3.8 Carriage Unit

a. Removing the carriage unit

- (1) Drain the printer of inks. See Disassembly/Reassembly > Tips on Disassembly/Reassembly > Ink Drain.
- (2) Switch off the printer and move the carriage to above the platen. See Disassembly/Reassembly > Tips on Disassembly/Reassembly > Open Cap/Shift Wiper Unit.
- (3) Remove the shaft cleaner, tube holder cover and tube holder.
- (4) Remove the printhead.
- (5) Disconnect all connectors from the carriage relay PCB.
- (6) Remove the printhead fixer lever assembly.
- (7) Cover the printhead-side joint of the ink tube unit in a plastic bag or the like to prevent ink splashing and leakage, and seal the mouth of the bag.

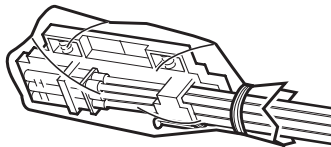

F-4-21

- (8) Release the ink tube unit from the carriage.
- (9) Remove the pulley stand[3] and the feed roller plate[4], and release the carriage unit[1] from the left side of the printer.

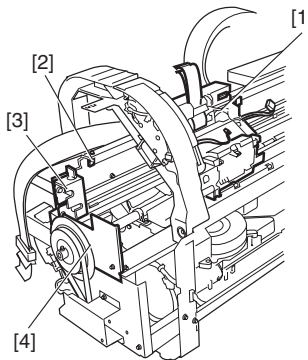

F-4-22



In removing the carriage unit, extract it level so that its protective mylar[2] sheets will not come off. If the protective mylar sheets should come off, the carriage unit rollers could come into contact with each other, rattling to or they could be damaged to degrade print quality.

b. Installing the carriage belt

Install the carriage belt[2] with its complete set of teeth engaged with carriage belt stopper[1].

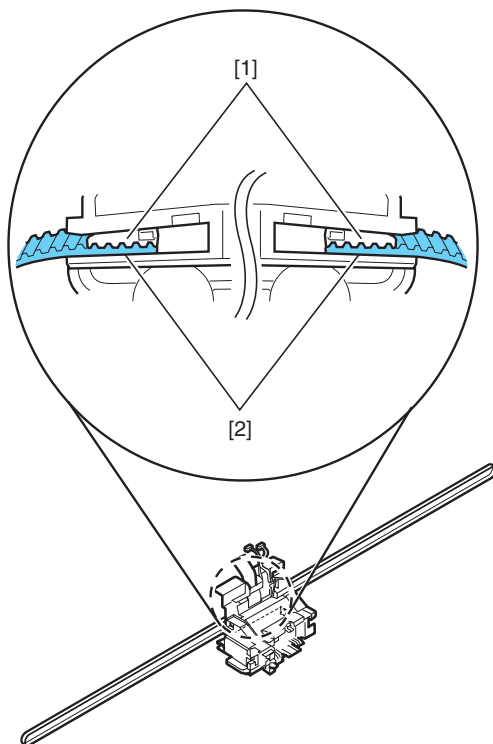

F-4-23

c. Action following the replacement of the carriage unit/multi sensor

Because the distance between the multisensor (in the carriage unit) and the nozzles (in the printhead) is varied from one unit to another, the printer as shipped has its optical axis corrected to adjust the image write position. When the carriage unit or multisensor has been replaced or disassembled and reassembled, they require adjustment.

Execute service mode under the following conditions:

* The multi sensor reference plate must be replaced at the same time whenever the carriage or the multi sensor is being replaced.

- Service mode : SERVICE MODE > ADJUST > GAP CALIB.

- Service mode : SERVICE MODE > ADJUST > PRINT PATTERN > OPTICAL AXIS

Media type : Photo glossy paper

Media size : Media having a width equal to or larger than that of A2-size paper

d. Removing the head holder

- (1) Drain the printer of inks. See Disassembly/Reassembly > Tips on Disassembly/Reassembly > Ink Drain.
- (2) Switch off the printer and move the carriage to above the platen. See Disassembly/Reassembly > Tips on Disassembly/Reassembly > Open Cap/Shift Wiper Unit.
- (3) Remove the shaft cleaner, tube holder cover and tube holder.
- (4) Remove the printhead.
- (5) Disconnect all connectors from the carriage relay PCB.
- (6) Release the two flexible cables from the carriage claws (to prevent the elevation and defective contact of the flexible cable on the head holder side).
- (7) Remove the printhead fixer lever assembly.
- (8) Cover the printhead-side joint of the ink tube unit in a plastic bag or the like to prevent ink splashing and leakage, and seal the mouth of the bag.

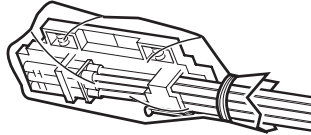

F-4-24

(9) To remove the head holder, press the lock pin located rearward to its left with a flat-blade screwdriver or similar object in the direction of the arrow mark.

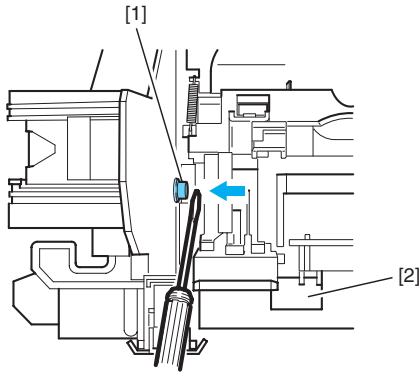

F-4-25

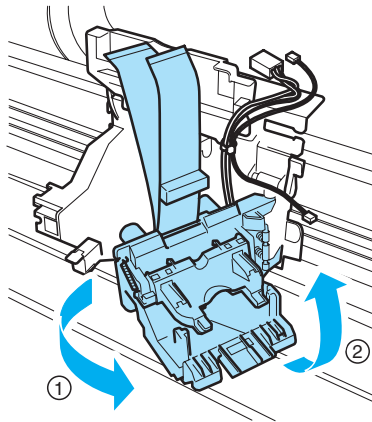

F-4-26

e. Reassembling the head holder

After the head holder has been reassembled, check that it lifts up and down in sync with the printhead height adjustment lever.

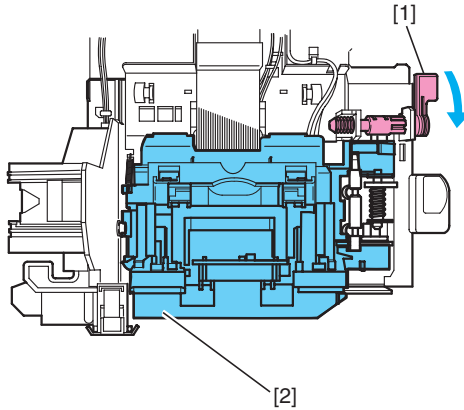

F-4-27

f. Multisensor correction

Since multi sensors have individual electrical specificity, the following are recalibrated at the factory, namely, the optical axis of the sensor, the sensor gain for measuring the printhead height and sensor reproduction. Accordingly, carry out the following adjustments in the service mode whenever replacing the carriage unit or multi sensor.

* The multi sensor reference plate must be replaced at the same time whenever the carriage or the multi sensor is being replaced.

- Service mode : SERVICE MODE > ADJUST > GAP CALIB.

- Service mode : SERVICE MODE > ADJUST > PRINT PATTERN > OPTICAL AXIS

Media type : Photo glossy paper

Media size : Media having a width equal to or larger than that of A2-size paper

4.3.9 Feeder Unit

a. Handling the feed roller



The feed roller is a functionally vital part. Observe these precautions when handling it:

- Do not handle the feed roller with one hand or deflect it.
- Do not touch the roller surface (coated side).
- Do not flaw or dent the roller surface.
- Hold the feed roller by two positions shown below: holding position A and one of holding positions B, C and D.

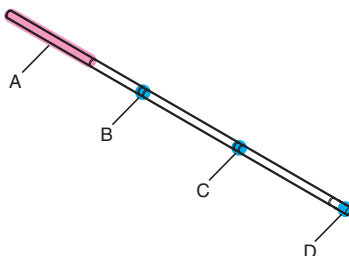

F-4-28

b. Action following the replacement of the feed roller

This printer as shipped has the feed roller eccentricity (that is, variations in the rate of paper feed from rotation to rotation) corrected for enhanced media feed accuracy. When the feed roller, feed roller HP sensor or feed roller encoder pertaining to the correction of eccentricity variations has been replaced or when the feed roller has been replaced or disassembled and reassembled, therefore, the feed roller should require adjustment.

Execute service mode under the following conditions:

Service mode SERVICE MODE > ADJUST > PRINT PATTERN > LF TUNING

Media type: Gloss photo paper

Paper size: 36 inches

If adjustment cannot be done properly by selecting "SERVICE MODE > ADJUST > PRINT PATTERN > LF TUNING" (auto adjustment), carry out manual adjustment.

Service mode SERVICE MODE > ADJUST > PRINT PATTERN > LF TUNING2

Media type: Gloss photo paper

Paper size: 36 inches

Check the printed pattern and enter values for adjustment.

4.3.10 Purge Unit

b. Removing the purge unit

- (1) Switch off the printer and move the carriage to above the platen. See Disassembly/Reassembly > Points to Note on Disassembly and Reassembly > Opening the Cap/Moving the Wiper Unit.
- (2) Disconnect the ground wire from the side of the purge unit.
- (3) Remove the connector and release the harness from the harness guide.
- (4) Unscrew four screws[4] and remove the waste ink tube joint[2], and then remove the purge unit[1].

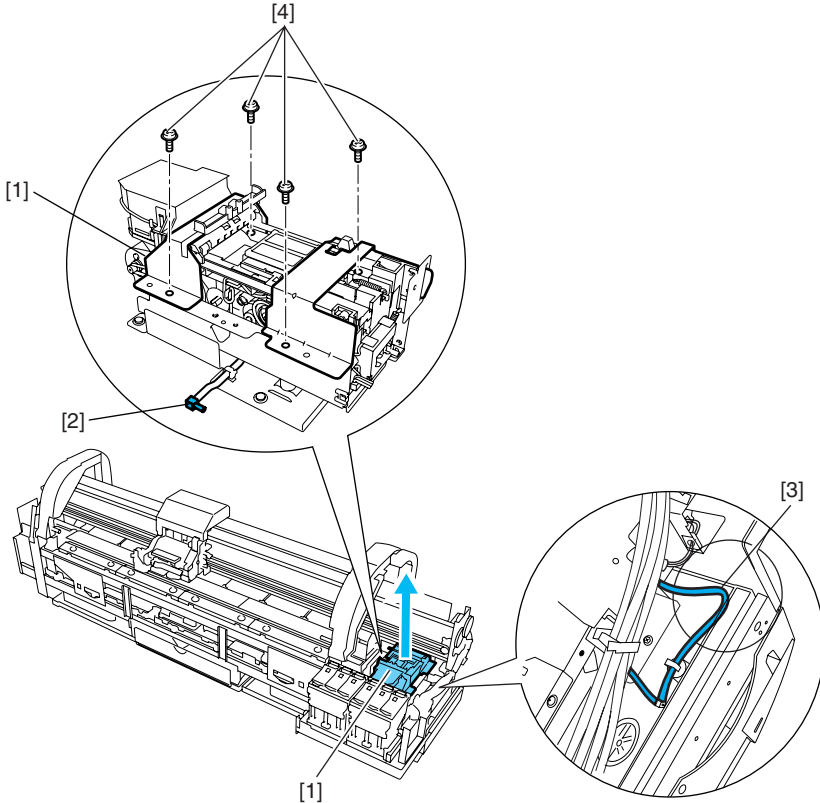

F-4-29



- Install the purge unit with care not to let the waste ink tube[3] bent.
- Exchange absorbents that exist under the purge unit at the same time when you exchange purge unit.

4.3.11 Ink Tank Unit

a. Removing the ink tank unit

- (1) Drain the printer of inks. See Disassembly/Reassembly > Point to Note on Disassembly and Reassembly > Draining the Ink.
- (2) Remove the joint between the ink tube unit and the ink tank unit.
- (3) Remove the four screws[2], remove five connectors and two hooks[1], then remove the ink tank unit.

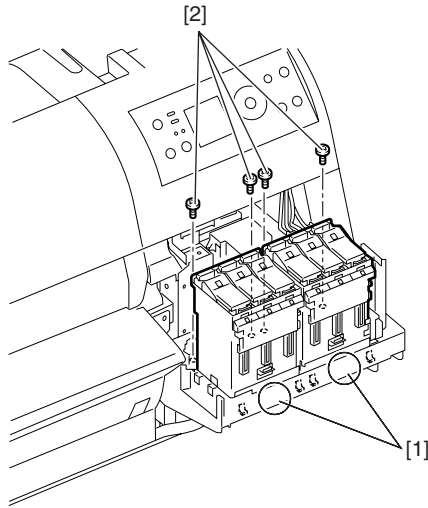

F-4-30

b. Removing the valve motor unit

(1) Remove four screws[2] and remove one screw, and then remove the valve motor unit[1].

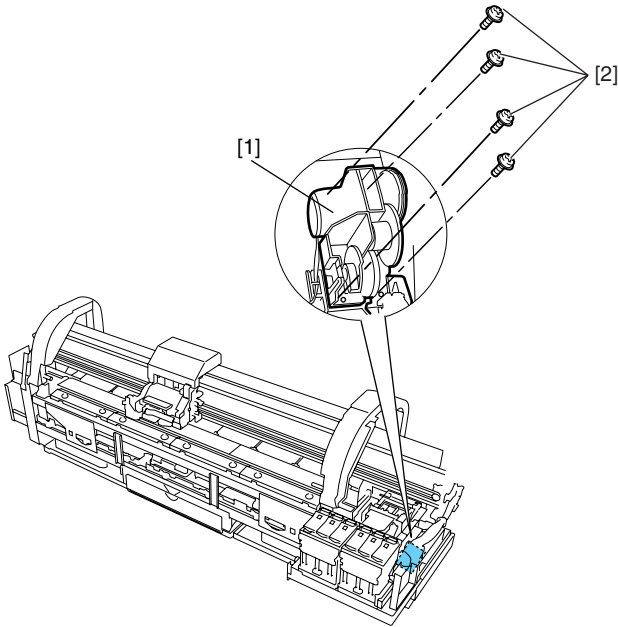

F-4-31

4.3.12 Head Management Sensor

a. Installing the head management sensor

- (1) Attach the connector[2] to the head management sensor[1] and then set the head management sensor[1] where it is to be mounted and fasten it with screw[3].

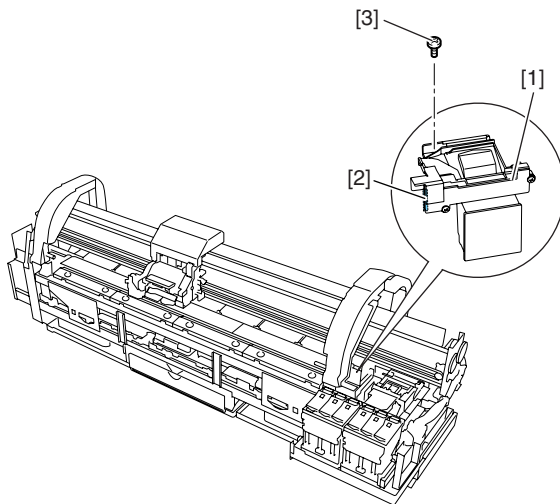

F-4-32

b. Procedure after replacing the head management sensor

The optical axis is compensated at factory shipment in order to adjust the non-discharge detection position because there are fluctuations among machines in the distance between the head management sensor and carriage unit. Therefore, adjustment must be made when the head management sensor is replaced or disassembling/assembling components that may cause error in the distance between the head management sensor and carriage unit.

Enter the service mode as follows:

SERVICE MODE > ADJUST > NOZZLE CHK POS. > YES

4.3.13 Multi Sensor

a) Removing the multi sensor

(1) The head holder is opened.

See:

"Disassembly/Reassembly" > "Points to Note on Disassembly/Reassembly" > "Carriage unit" > "d. Removing the head holder"

(2) Remove the screw[1], disconnect the flexible cable[2], and then remove the multi sensor[3].

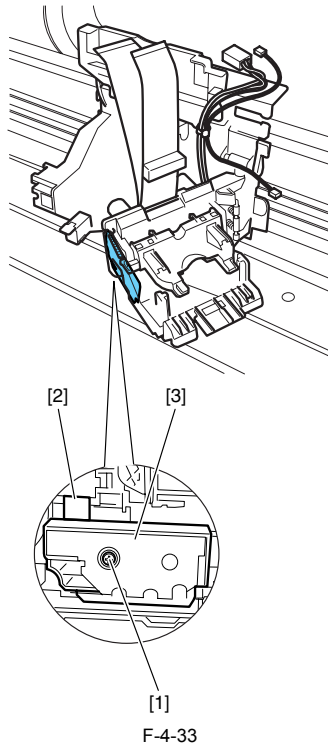

Since multi sensors have individual electrical specificity, the following are recalibrated at the factory, namely, the optical axis of the sensor, the sensor gain for measuring the printhead height and color reproduction. Accordingly, carry out the following adjustments in the service mode whenever replacing the carriage unit or multi sensor.

* The multi sensor reference plate must be replaced at the same time whenever the carriage or the multi sensor is being replaced.

* When replacing the carriage unit, refer to **Adjustment and Setup > Procedure after Removing or Replacing the Carriage Unit.**

- Service mode : SERVICE MODE > ADJUST > GAP CALIB.

- Service mode : SERVICE MODE > ADJUST > PRINT PATTERN > OPTICAL AXIS

Media type : Photo glossy paper

Media size : Media having a width equal to or larger than that of A1-size paper

4.3.14 PCBs

Do not replace the main controller PCB and maintenance cartridge relay PCB(ROM board) at the same time. These PCBs store important data such as settings and carriage drive time. Before replacement of either PCB, the data stored in it is move to the other PCB through internal communication so that it can be taken over to the new PCB automatically. This is the reason why the two PCBs should not be replaced at the same time.

If you want to replace both PCBs at the same time, first carry out the procedure "a" and then carry out the procedure "b".

After replacing with the maintenance controller PCB or maintenance cartridge relay PCB which are supplied as service parts, check that the firmware to the latest version.

a) Procedure for replacing the maintenance cartridge relay PCB(ROM board)

- 1) Turn off the printer and unplug the power cord.
- 2) Replace the maintenance cartridge relay PCB.
- 3) Plug the power cord to the outlet, and then turn on the printer with the PAPER SOURCE button and INFORMATION button pressed down. (The printer will start up in the PCB Replacement mode.)
- 4) Check that "Initializing" appears on the display, and then release the buttons. (When the printer enters the PCB Replacement mode, the message lamp goes on.)
- 5) Wait until "REPLACE MODE" appears on the display.
- 6) Select "MC BOARD", and then press the ok button
- 7) Check that "TURN POWER OFF" appears on the display, and then turn off the printer.
- 8) Turn on the printer.
- 9) Check the firmware version. If the firmware is not the latest version, update.

b) Procedure for replacing the main controller PCB

- 1) Turn off the printer and unplug the power cord.
- 2) Replace the main controller PCB.
- 3) Plug the power cord to the outlet, and then turn on the printer with the PAPER SOURCE button and INFORMATION button pressed down. (The printer will start up in the PCB Replacement mode.)
- 4) Check that "Initializing" appears on the display, and then release the buttons. (When the printer enters the PCB Replacement mode, the message lamp goes on.)
- 5) Wait until "REPLACE MODE" appears on the display.
- 6) Select "CPU BOARD", and then press the ok button
- 7) Check that "TURN POWER OFF" appears on the display, and then turn off the printer.
- 8) Turn on the printer.
- 9) Check the firmware version. If the firmware is not the latest version, update.

4.3.15 Opening the Cap/Moving the Wiper Unit

The procedures for manually opening the caps and ink supply valves are presented below. The carriage lock pin and caps need to be released manually if moving the carriage when the power is turned off.

1. Opening the caps and releasing the carriage lock pins

- 1) Remove the right side cover, right rear cover, and right upper cover.
- 2) Turn the gear [1] of the purge unit [3] in the direction of the arrow. The cap [5] and lock pin [4] move down, allowing you to move the carriage [2].

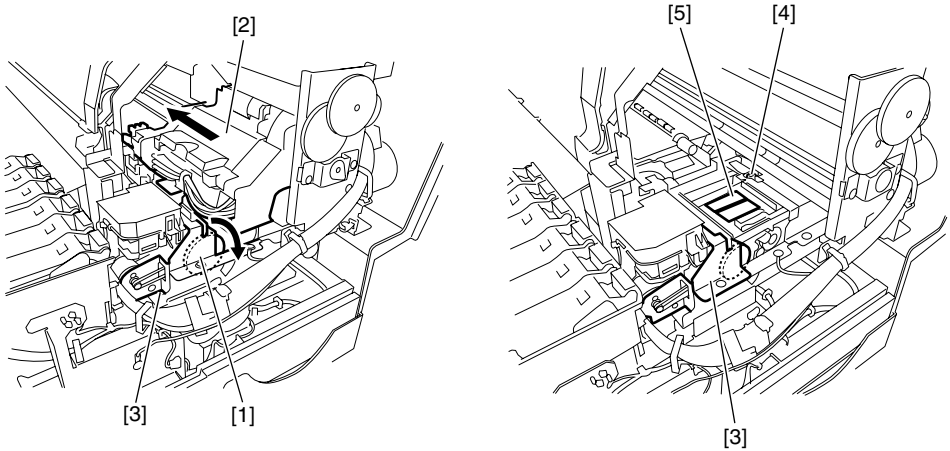

F-4-34

MEMO:

After opening the caps and removing the carriage lock pin, rotating the gear further will close the caps after the wiper unit has completed the return movement, and the carriage lock pin will rise and lock the carriage.

2. Moving the wiper unit

- 1) Remove the right side cover, right rear cover, and right upper cover.
- 2) To move the wiper unit[3], turn the gear[1] of the purge unit[2] in the direction of the arrow.

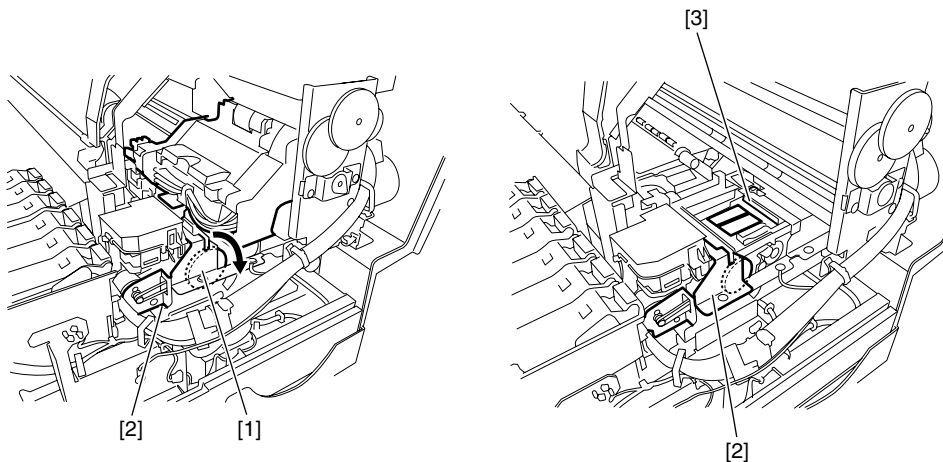

F-4-35

4.3.16 Opening/Closing the Ink Supply Valve

- 1) Remove the right side cover.
- 2) To open the ink supply valve, turn the cam[2] in the direction of the arrow and press the link[1].



- If the tube is full of ink, releasing the printhead lock lever with the ink supply valve open can cause the ink to flow back to the ink supply unit, resulting in leakage of ink from the ink supply needle.
- If the ink supply valve is held open due to a problem such as a valve motor error(03130031-2F3A), remove the valve motor unit(refer to DISASSEMBLY/REASSEMBLY > Points to Note on Disassembly and Reassembly > Ink Tank Unit) and close the ink supply valve.

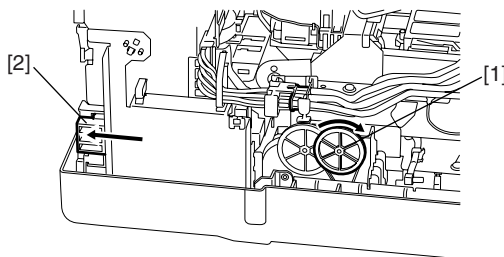

F-4-36

4.3.17 Draining the Ink

There are two methods of removing the ink, using a manual method or automatic method. When the ink is drained, the ink inside the ink passage totaling about 228g (about 38g x 6 colors) is drained as waste ink.



To prevent ink leaks, be sure to always remove the ink inside the ink passage when disassembling or transporting the parts of the ink passage section.

1. Automatic ink drainage

Automatic ink drainage is performed by going to the Main Menu and selecting "Maintenance" > "Move Printer". It takes about 4 minutes for automatic ink drainage to be performed.



Perform automatic ink drainage again if a power outage or other cause shuts off the power during the operation for automatic ink drainage.

2. Manual ink drainage

A syringe or other implement is used to remove the ink inside the ink passages one color at a time in the event of a printer electrical failure, firmware error, or malfunction in supplying power to the printer.

Manual Ink Drainage Procedure

- (1) Remove ink tank cover. Refer to "Disassembly/Reassembly" > "Point to Note on Disassembly and Reassembly" > "External cover"
- (2) Move the carriage onto the platen. Refer to "Disassembly/Reassembly" > "Point to Note on Disassembly and Reassembly" > "Opening the Cap/Move the Wiper Unit".
- (3) Turn the cam [1] in the direction of the arrow, and then press the link [2] to open the ink supply valve.

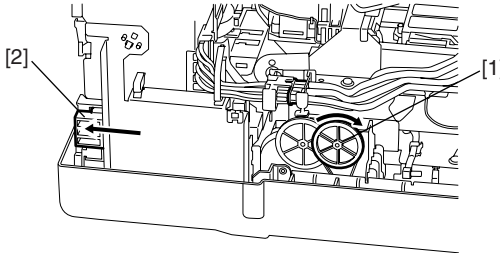

F-4-37

- 4) Release both printhead fixer levers [1] to flow the ink from inside the ink tube to the sub-buffer of the ink tank unit.

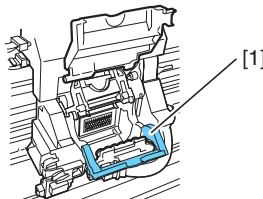

F-4-38

4.4 Applying the Grease

4.4.1 Applying the Grease

Apply the grease at the location shown below.
Smear the grease lightly and evenly with a flat brush.



Don't apply the grease to locations other than those designated. Unwanted grease may cause poor print quality, take particular care that grease does not get onto the wiper, cap, or the linear scale.

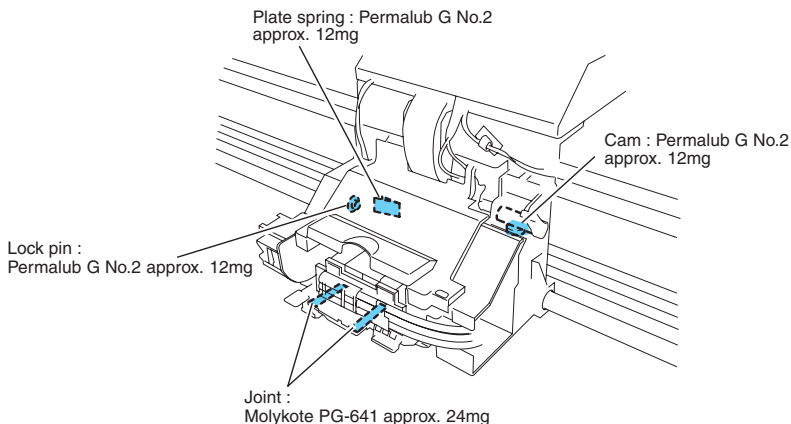

F-4-39

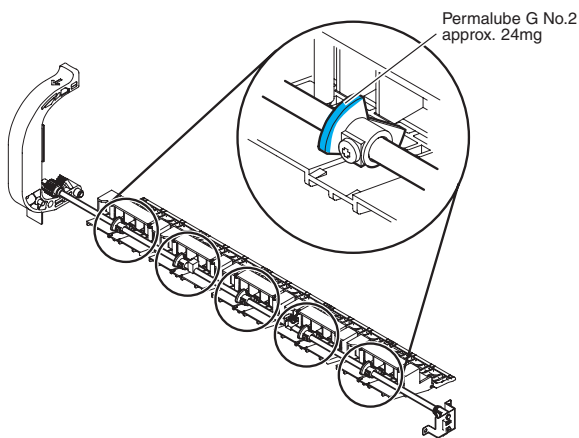

F-4-40

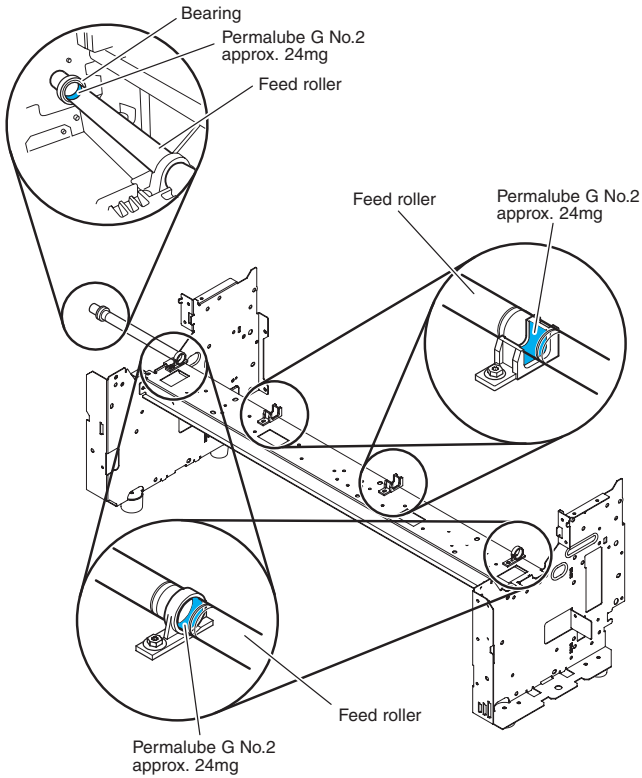

F-4-41

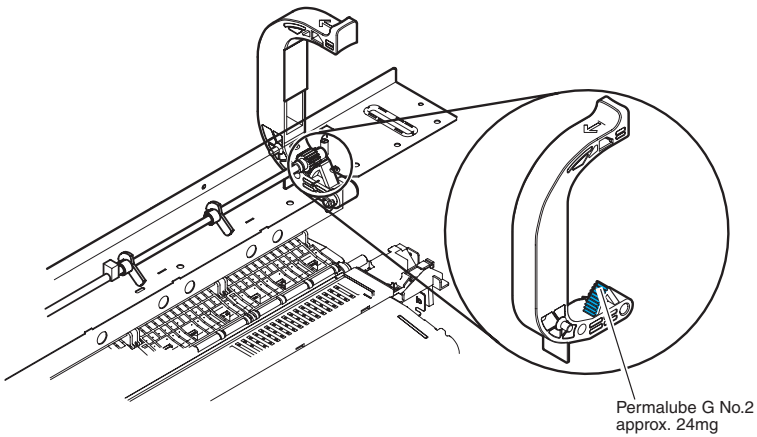

F-4-42

4.5 Adjustment and Setup Items

4.5.1 Adjustment Item List

The following adjustment procedures need to be performed when parts have been replaced or removed and then reinstalled:

T-4-1

Adjustment item	Adjustment timing
Multi sensor recalibration	Multi sensor replacement/removal
	Carriage unit replacement/removal
Adjusting feed roller eccentricity	Feed roller
	Feed roller encoder
Head management sensor recalibration	Head management sensor replacement/removal
	Carriage unit replacement/removal

4.5.2 Procedure after Replacing the Feed Roller or Feed Roller Encoder

Feed roller eccentricity is factory-adjusted (correction of variation in the paper feed amount per rotation). It is necessary to adjust feed roller eccentricity after replacing the feed roller or feed roller encoder. In the service mode, perform automatic adjustment of feed roller eccentricity.

Service mode : SERVICE MODE > ADJUST > PRINT PATTERN > LF TUNING

Media type : Photo glossy paper

Media size : Media having awidth equal to or larger than that of A2-size paper

If adjustment cannot be done properly by selecting "SERVICE MODE > ADJUST > PRINT PATTERN > LF TUNING" (auto adjustment), carry out manual adjustment.

Service mode : SERVICE MODE > ADJUST > PRINT PATTERN > LF TUNING2

Media type : Photo glossy paper

Media size : Media having awidth equal to or larger than that of A2-size paper

Check the printed pattern and enter values for adjustment.

4.5.3 Procedure after Replacing the Carriage Unit or Multi Sensor

a) Multi Sensor Recalibration

Since multi sensors have individual electrical specificity, the following are recalibrated at the factory, namely, the optical axis of the sensor, the sensor gain for measuring the printhead height and color reproduction. Accordingly, carry out the following adjustments in the service mode whenever replacing the carriage unit or multi sensor.

 The multi sensor reference plate must be replaced at the same time whenever the carriage or the multi sensor is being replaced.

-Service mode : SERVICE MODE > ADJUST > GAP CALIB.

-Service mode : SERVICE MODE > ADJUST > PRINT PATTERN > OPTICAL AXIS

Media type : Photo glossy paper

Media size : Media having a width equal to or larger than that of A2-size paper

4.5.4 Procedure after Replacing the Head Management Sensor

Since the distance between the head management sensor and the carriage unit varies among printers, the optical axis is factory-adjusted to adjust the non-discharging detection position. When you have replaced the head management sensor or performed assembly/reassembly of surrounding parts that can change the distance between the head management sensor and the carriage unit, readjustment is required. Perform the readjustment in the service mode.

Service mode : SERVICE MODE > ADJUST > NOZZLE CHK POS.

Chapter 5 MAINTENANCE

Contents

5.1 Periodic Replacement Parts	5-1
5.1.1 Periodic Replacement Parts	5-1
5.2 Consumable Parts	5-1
5.2.1 Consumable Parts	5-1
5.3 Periodic Maintenance	5-2
5.3.1 Periodic Maintenance	5-2

5.1 Periodic Replacement Parts

5.1.1 Periodic Replacement Parts

T-5-1

Level	Periodic Replacement part
User	None
Service Personnel	None

5.2 Consumable Parts

5.2.1 Consumable Parts

T-5-2

	Consumables				Service Mode		
	Name	Part number	Q'ty	Life sheets /A0	PARTS xx	COUNTER x	States (Error Code)
Service	WASTE INK TANK UNIT	QM3-1369-030	2	12000	A1/A2	A	OK/W1/E146-4001
	MIST FAN	QL2-1053-000	2	12000	A1/A2		
	ABSORBER, DUCT	QC2-2999-000	2	12000	A1/A2		
	BASE, MULTI SENSOR REFERENCE	QL2-1738-000	1	12000	A2		
	CARRIAGE UNIT	QM3-3330-000	1	12000	D1/D2/D3	D	OK/W1/W2
	SCALE, LINEAR	QC2-2697-000	1	12000	D2		
	TUBE UNIT	QM3-3329-000	1	12000	F1	F	OK/W1/W2
	PURGE UNIT	QM3-1413-000	1	12000	H1	H	OK/W1/E141-4046
	HEAD MANAGEMENT SENSOR UNIT	QM3-1395-000	1	12000	K1	K	OK/W1/W2//E194-404A
	MOTOR, CARRIAGE	QM3-1401-000	1	12000	M1	M	OK/W1/W2
User	See "Product Overview> Features> Consumables"						



After supplies have been replaced, execute [INITIALIZE] > [PARTS COUNTER] > [PARTS xx] in service mode to initialize (clear) the parts counter information.

5.3 Periodic Maintenance

5.3.1 Periodic Maintenance

T-5-3

Level	Periodic maintenance
User	Cleaning of ink mist and other substances (about once each month)
Service personnel	None

a) Printer cleaning

To keep up with print quality and prevent troubles, clean the printer about once each month.

1) Using a damp cloth wringed well, wipe dirt and paper dust off the printer exterior, paper feed slot [1], and power plug. Next, rub them with a dry cloth.

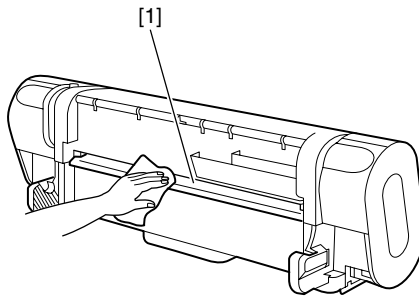

F-5-1

- 2) Press the [MENU] button to display the main menu.
- 3) Press the ▲ and ▼ buttons to select [Maintenance] and then press the ► button.
- 4) Press the ▲ and ▼ buttons to select [Platen Cleaning] and press the ► button.
- 5) Press the ▲ and ▼ buttons to select [Yes] and press [OK] button.
- 6) Open the top cover.

7) If chad has deposited on suction port [1] on the platen or in borderless printing ink receiving channel [2], wipe it off with the cleaner brush [3].

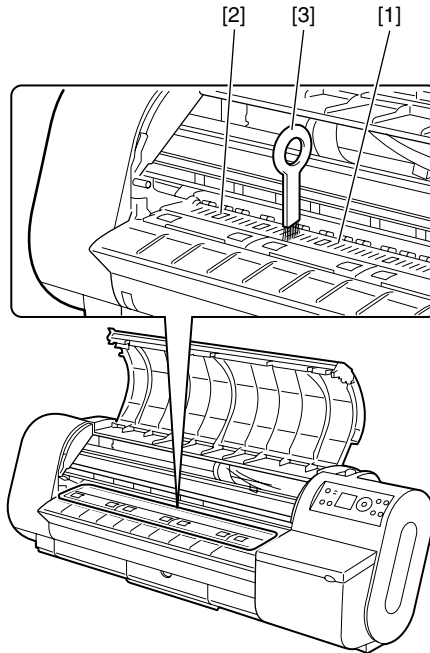

F-5-2

MEMO:

Rinse the cleaner brush with water when it gets dirty.

8) Using a damp cloth wringed well, wipe dirt off the inside of the top cover. Wipe ink contamination off the roller [1], overall surface of the platen [2], pinch roller unit [3], borderless print ink receiving groove [4], delivery guide [5], and guide rail [6].

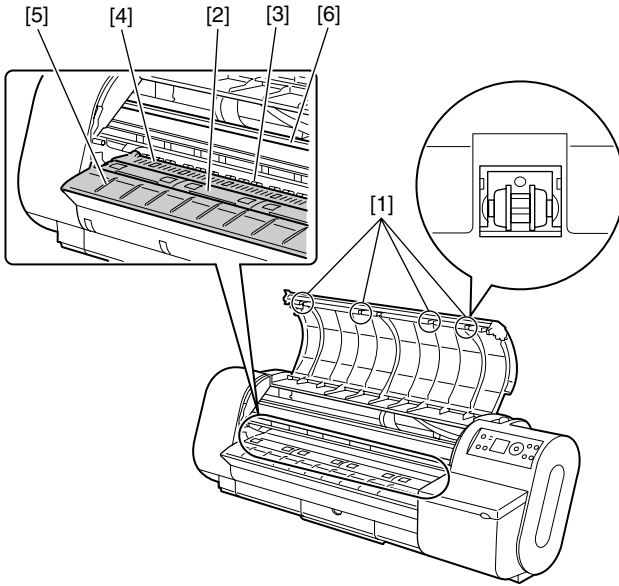

F-5-3



- Do not dry the interiors of the top cover with a dry cloth. Electrostatic charges could make the internal components susceptible to dirt, resulting in degraded print quality.
- Do not use flammable solvents, such as thinner and benzene, on the printer. Solvents coming into contact with any electrical parts inside the printer could result in fires or electrical shock hazards.
- Do not touch linear scale [1] and carriage shaft [2].

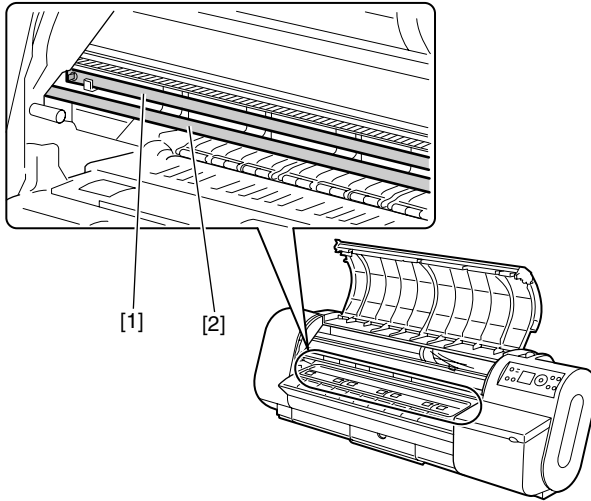

F-5-4

- 9) Remove the roll feed unit and fold plain paper two to three times and then insert through the printer rear into the underside of the pinch roller unit to wipe off dirt on the pinch roller unit.

Chapter 6 TROUBLESHOOTING

Contents

6.1 Troubleshooting.....	6-1
6.1.1 Outline	6-1
6.1.1.1 Outline of Troubleshooting.....	6-1
6.2 Location of Connectors and Pin Arrangement	6-2
6.2.1 Main controller PCB.....	6-2
6.2.2 Carriage relay PCB	6-12
6.2.3 Head relay PCB.....	6-19
6.3 Version Up.....	6-24
6.3.1 Firmware Update Tool.....	6-24
6.4 Service Tools	6-25
6.4.1 Tool List	6-25
6.4.2 Using the Cover Switch Tool.....	6-26

6.1 Troubleshooting

6.1.1 Outline

6.1.1.1 Outline of Troubleshooting

1. Overview

Targets of troubleshooting are classified into the troubles displayed on the LCD (i.e., warnings, errors, and service calls) and the troubles not displayed on the LCD.

Warnings and errors are displayed on the printer's LCD along with a code comprising alphanumeric characters.

2. Precautions for Troubleshooting

- 1) Check the environmental conditions and the media used.
- 2) Before starting troubleshooting, check that the connectors and cables are connected properly.
- 3) If you repair the printer with its external panel detached without disconnecting the AC cord from the outlet, take great care to prevent electric shock and short-circuiting of PC boards.
- 4) Countermeasures to take after completion of troubleshooting are described starting with the most probable component that can cause the trouble determined by troubleshooting. If there are two or more equally probable components, countermeasures are described starting with the component that requires the easiest repair. After performing each countermeasure step, carry out test printing to check whether the problem has been solved. If not solved, try the next countermeasure step.
- 5) After completion of troubleshooting, check that all the necessary connectors and screws have been installed securely.
- 6) After completion of replacement or repair of a component, be sure to carry out test printing to make sure that the trouble has been solved.

6.2 Location of Connectors and Pin Arrangement

6.2.1 Main controller PCB

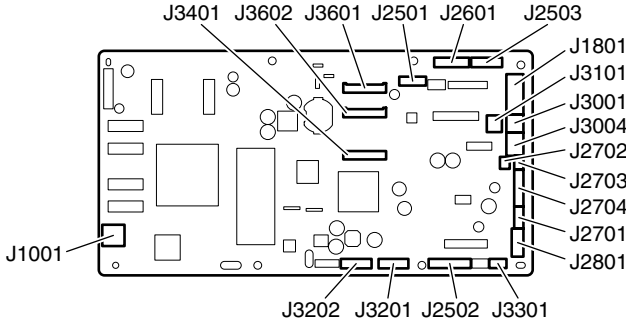

F-6-1

T-6-1

J1001			
Pin Number	Signal name	IN/OUT	Function
1	VBUS	IN	USB VBUS (+5V)
2	D-	IN/OUT	USB data (-)
3	D+	IN/OUT	USB data (+)
4	GND	-	USB GND

T-6-2

J1801			
Pin Number	Signal name	IN/OUT	Function
1	AFCONT	OUT	Normal/power saving switch signal
2	VM_ENB	OUT	VM enable signal
3	VMGND	-	GND
4	VMGND	-	GND
5	VM	IN	Power supply (+32V)
6	VM	IN	Power supply (+32V)
7	GND	-	GND
8	GND	-	GND
9	GND	-	GND
10	RGV20(+5V)	IN	Power supply (+5V)
11	RGV20(+5V)	IN	Power supply (+5V)
12	RGV20(+5V)	IN	Power supply (+5V)

T-6-3

J2501			
Pin Number	Signal name	IN/OUT	Function
1	PUMPM1_AM	OUT	Purge motor Drive signal AM
2	PUMPM1_AP	OUT	Purge motor Drive signal AP
3	GND	-	GND
4	PUMPR_ENCA	IN	Pump encoder output signal A
5	SNS5V	OUT	Power supply (+5V)
6	PUMPR_ENCB	IN	Pump encoder output signal B
7	SNS3V	OUT	Power supply (+3.3V)
8	GND	-	GND
9	/CONTROL_CAM_R	IN	Pump cam sensor output signal

T-6-4

J2502			
Pin Number	Signal name	IN/OUT	Function
1	INKBENM1_AM	OUT	Valve motor drive signal AM
2	INKBENM1_AP	OUT	Valve motor drive signal AP
3	SNS3V	OUT	Power supply (+3.3V)
4	GND	-	GND
5	/INKBEN_OPEN_R	IN	Valve open/close detection sensor output signal
6	/TANKCOVER_R	IN	Ink tank cover switch output signal
7	GND	-	GND
8	GND	-	GND
9	+5V	OUT	Power supply (+5V)
10	HUM	IN	Humidity sensor output signal
11	GND	-	GND
12	TH	IN	Thermistor output signal
13	GND	-	GND
14	/FUTO_ON	OUT	Head management sensor ON/OFF signal
15	+5V	OUT	Power supply (+5V)
16	/FUTO_CMP	IN	Head management sensor ink detection signal

T-6-5

J2503			
Pin Number	Signal name	IN/OUT	Function
1	GND	-	GND
2	/MEDIA_R	IN	Media sensor output signal

J2503			
Pin Number	Signal name	IN/OUT	Function
3	MEDIA5V	OUT	Power supply (+5V)
4	SNS3V	OUT	Power supply (+3.3V)
5	GND	-	GND
6	/CRHP	IN	Lift cam sensor output signal
7	LIFTM_VM	OUT	Power supply (+32V)
8	LIFTM0_A	OUT	Lift motor Drive signal A
9	LIFTM2_AX_N0	OUT	Lift motor Drive signal AX
10	LIFTM1_B	OUT	Lift motor Drive signal B
11	LIFTM3_BX_N1	OUT	Lift motor Drive signal BX

T-6-6

J2601			
Pin Number	Signal name	IN/OUT	Function
1	POWER_ON	IN	Power switch signal
2	GND	-	GND
3	RGV20(+5V)	OUT	Power supply (+5V)
4	BUZZER	OUT	Buzzer control signal
5	PDO	OUT	Panel IC control signal
6	+5V	OUT	Power supply (+5V)
7	PDI	OUT	Panel IC data signal
8	N.C.(HDD_LED)	-	N.C
9	/PRESET	OUT	Panel reset signal
10	GND	-	GND
11	PCK	OUT	Panel IC clock signal
12	PANEL5V_ON	OUT	Power supply (+5V)
13	/PCS	OUT	Panel IC chip select signal

T-6-7

J2701			
Pin Number	Signal name	IN/OUT	Function
1	GND	-	GND
2	LFENCB	IN	Feed roller encoder output signal B
3	LFENC_ON(+5V)	OUT	Power supply (+5V)
4	LFENCA	IN	Feed roller encoder output signal A
5	SNS3V	OUT	Power supply (+3.3V)
6	GND	-	GND
7	/LF_HP	IN	Feed roller HP sensor output signal

T-6-8

J2702			
Pin Number	Signal name	IN/OUT	Function
1	VM 26V	OUT	Power supply (+26V)
2	DCOVER_SOL	OUT	Upper cover lock solenoid (L) drive signal

T-6-9

J2703			
Pin Number	Signal name	IN/OUT	Function
1	VM 26V	OUT	Power supply (+26V)
2	DCOVER_SOL	OUT	Upper cover lock solenoid (R) drive signal
3	N.C	-	N.C

T-6-10

J2704			
Pin Number	Signal name	IN/OUT	Function
1	VM_26V	OUT	Power supply (+26V)
2	KYUINFAN_ALARM	IN	Suction fan alarm signal
3	KYUINFAN_PWM	OUT	Suction fan duty control signal
4	GND	-	GND
5	VM_26V	OUT	Power supply (+26V)
6	MISTFAN_R_ALARM	IN	Mist fan (R) alarm signal
7	GND	-	GND
8	VM_26V	OUT	Power supply (+26V)
9	MISTFAN_L_ALARM	IN	Mist fan (L) alarm signal
10	GND	-	GND
11	VM_26V	OUT	Power supply (+26V)
12	SPOOL_CL	OUT	Roll media rewinding clutch drive signal
13	/ATUKAIJYO	IN	Pressure release switch output signal
14	GND	-	GND

T-6-11

J2801			
Pin Number	Signal name	IN/OUT	Function
1	LFSP_A	OUT	Feed motor drive signal A
2	LFSP_VM	OUT	Power supply (+32V)

J2801			
Pin Number	Signal name	IN/OUT	Function
3	LFSP_AB	OUT	Feed motor drive signal AB
4	LFSP_BB	OUT	Feed motor drive signal BB
5	LFSP_VM	OUT	Power supply (+32V)
6	LFSP_B	OUT	Feed motor drive signal B

T-6-12

J3001			
Pin Number	Signal name	IN/OUT	Function
1	VM	OUT	Power supply (+32V)
2	-	-	-

T-6-13

J3004			
Pin Number	Signal name	IN/OUT	Function
1	-	-	-
2	VM_CR	IN	Upper cover lock switch output signal
3	N.C	-	N.C

T-6-14

J3101			
Pin Number	Signal name	IN/OUT	Function
1	CRM_C	OUT	Carriage motor phase drive signal (C)
2	CRM_B	OUT	Carriage motor phase drive signal (B)

T-6-15

J3201			
Pin Number	Signal name	IN/OUT	Function
1	TANK_CLK	OUT	Ink tank clock signal
2	GND	-	GND
3	TANK_DAT2	IN/OUT	Ink tank data signal 2
4	TANK_ON(+3.3V)	OUT	Power supply (+3.3V)
5	TANK_DAT1	IN/OUT	Ink tank data signal 1
6	TANK_DAT0	IN/OUT	Ink tank data signal 0

J3201			
Pin Number	Signal name	IN/OUT	Function
7	GND	-	GND
8	INK_DETECT0	IN	Ink detection sensor output signal 0
9	INK_DETECT1	IN	Ink detection sensor output signal 1
10	INK_DETECT2	IN	Ink detection sensor output signal 2

T-6-16

J3202			
Pin Number	Signal name	IN/OUT	Function
1	TANK_CLK	OUT	Ink tank clock signal
2	GND	-	GND
3	TANK_DAT8	IN/OUT	Ink tank data signal 8
4	TANK_ON(+3.3V)	OUT	Power supply (+3.3V)
5	TANK_DAT7	IN/OUT	Ink tank data signal 7
6	TANK_DAT6	IN/OUT	Ink tank data signal 6
7	GND	-	GND
8	INK_DETECT6	IN	Ink detection sensor output signal 6
9	INK_DETECT7	IN	Ink detection sensor output signal 7
10	INK_DETECT8	IN	Ink detection sensor output signal 8
11	N.C	-	N.C

T-6-17

J3301			
Pin Number	Signal name	IN/OUT	Function
1	MENT_SDA	IN/OUT	Maintenance cartridge ROM control signal (data)
2	MENT_SCL	IN/OUT	Maintenance cartridge ROM control signal (clock)
3	GND	-	GND
4	+3.3V	OUT	Power supply (+3.3V)
5	N.C	-	N.C

T-6-18

J3401			
Pin Number	Signal name	IN/OUT	Function
1	VMGND	-	GND
2	VMGND	-	GND
3	VMGND	-	GND
4	VMGND	-	GND

J3401			
Pin Number	Signal name	IN/OUT	Function
5	VH_MONI1	IN	VH control signal 1
6	VH_ENB	OUT	VH power supply ON/OFF signal
7	VH_MONI2	IN	VH control signal 2
8	GND	-	GND
9	+3.3V	OUT	Power supply (+3.3V)
10	+3.3V	OUT	Power supply (+3.3V)
11	GND	-	GND
12	SNS5V	OUT	Power supply (+5V)
13	SNS5V	OUT	Power supply (+5V)
14	VM	OUT	Power supply (+32V)
15	VM	OUT	Power supply (+32V)
16	VM	OUT	Power supply (+32V)
17	VM	OUT	Power supply (+32V)
18	VM	OUT	Power supply (+32V)
19	VM	OUT	Power supply (+32V)
20	VM	OUT	Power supply (+32V)
21	VM	OUT	Power supply (+32V)
22	VMGND	-	GND
23	VMGND	-	GND
24	VMGND	-	GND
25	VMGND	-	GND

T-6-19

J3601			
Pin Number	Signal name	IN/OUT	Function
1	GND	-	GND
2	H1-D-DATA-7-OD_B	OUT	Odd head data signal 7(D)
3	GND	-	GND
4	H1-E-HE-8_B	OUT	Head heat enable signal 8(E)
5	GND	-	GND
6	H1-E-DATA-8-EV_B	OUT	Even head data signal 8(E)
7	GND	-	GND
8	H1-F-DATA-10-OD_B	OUT	Odd head data signal 10(F)
9	GND	-	GND
10	H1-E-DATA-9-OD_B	OUT	Odd head data signal 9(E)
11	GND	-	GND
12	H1-F-HE-10_B	OUT	Head heat enable signal 10(F)
13	GND	-	GND

J3601			
Pin Number	Signal name	IN/OUT	Function
14	H1-F-DATA-11-OD_B	OUT	Odd head data signal 11(F)
15	GND	-	GND
16	H1-F-HE-11_B	OUT	Head heat enable signal 11(F)
17	GND	-	GND
18	H1-F-DATA-11-EV_B	OUT	Even head data signal 11(F)
19	GND	-	GND
20	H1-F-DATA-10-EV_B	OUT	Even head data signal 10(F)
21	GND	-	GND
22	H1-E-HE-9_B	OUT	Head heat enable signal 9(E)
23	GND	-	GND
24	H1-E-DATA-9-EV_B	OUT	Even head data signal 9(E)
25	GND	-	GND
26	H1-B-DATA-2-OD_B	OUT	Odd head data signal 2(B)
27	GND	-	GND
28	H1-B-DATA-3-OD_B	OUT	Odd head data signal 3(B)
29	GND	-	GND
30	H1-C-HE-4_B	OUT	Head heat enable signal 4(C)
31	GND	-	GND
32	H1-C-DATA-4-OD_B	OUT	Odd head data signal 4(C)
33	GND	-	GND
34	H1-B-HE-2_B	OUT	Head heat enable signal 2(B)
35	GND	-	GND
36	H1-A-DATA-1-OD_B	OUT	Odd head data signal 1(A)
37	GND	-	GND
38	H1-A-DATA-0-OD_B	OUT	Odd head data signal 0(A)
39	GND	-	GND
40	PWLED2_ON	OUT	Multi sensor LED2 drive signal
41	PWLED3_ON	OUT	Multi sensor LED3 drive signal
42	PWLED1_ON	OUT	Multi sensor LED1 drive signal
43	PWLED4_ON	OUT	Multi sensor LED4 drive signal
44	/CR_COVER	IN	Carriage cover sensor output signal
45	VH_DIS	OUT	VH selection signal
46	/OUT_ENB	OUT	Head data enable signal
47	/H3V_ON_B	OUT	Power supply (+3V)
48	MLT_SENS_1IN	IN	Multi sensor signal 1
49	MLT_SENS_2IN	IN	Multi sensor signal 2
50	GND	-	GND

J3602			
Pin Number	Signal name	IN/OUT	Function
1	GND	-	GND
2	H1-E-DATA-8-OD_B	OUT	Odd head data signal 8(E)
3	GND	-	GND
4	H1-D-HE-7_B	OUT	Head heat enable signal 7(D)
5	GND	-	GND
6	H1-D-DATA-7-EV_B	OUT	Even head data signal 7(D)
7	GND	-	GND
8	H1-D-DATA-6-EV_B	OUT	Even head data signal 6(D)
9	GND	-	GND
10	H1-D-DATA-6-OD_B	OUT	Odd head data signal 6(D)
11	GND	-	GND
12	H1-D-HE-6_B	OUT	Head heat enable signal 6(D)
13	GND	-	GND
14	H1-C-HE-5_B	OUT	Head heat enable signal 5(C)
15	GND	-	GND
16	H1-C-DATA-5-OD_B	OUT	Odd head data signal 5(C)
17	GND	-	GND
18	H1_CLK_B	OUT	Head clock signal
19	GND	-	GND
20	/H1_LT_B	OUT	Head latch signal
21	GND	-	GND
22	H1-C-DATA-5-EV_B	OUT	Even head data signal 5(C)
23	GND	-	GND
24	H1-B-HE-3_B	OUT	Head heat enable signal 3(B)
25	GND	-	GND
26	H1-C-DATA-4-EV_B	OUT	Even head data signal 4(C)
27	GND	-	GND
28	H1-B-DATA-3-EV_B	OUT	Even head data signal 3(B)
29	GND	-	GND
30	H1-B-DATA-2-EV_B	OUT	Even head data signal 2(B)
31	GND	-	GND
32	H1-A-DATA-1-EV_B	OUT	Even head data signal 1(A)
33	GND	-	GND
34	H1-A-HE-1_B	OUT	Head heat enable signal 1(A)
35	GND	-	GND
36	H1-A-DATA-0-EV_B	OUT	Even head data signal 0(A)
37	GND	-	GND
38	H1-A-HE-0_B	OUT	Head heat enable signal 0(A)
39	GND	-	GND

J3602			
Pin Number	Signal name	IN/OUT	Function
40	/ENCODER_A	IN	Carriage encoder output signal A
41	/ENCODER_B	IN	Carriage encoder output signal B
42	H-DASH_LICC2_B	OUT	Head analogue switch A/D trigger signal
43	H1-DASLK_LICC2	OUT	Head analogue switch clock signal
44	H1-DLD_LICC2	OUT	Head analogue switch latch signal
45	H1-DATA_LICC2	OUT	Head analogue switch data signal
46	H1-DSOUT2	IN	Head temperature output signal 2
47	H1-DSOUT1	IN	Head temperature output signal 1
48	IO_ASIC_SCL_B	IN/OUT	Head ROM control signal (clock)
49	IO_ASIC_SDA	IN/OUT	Head ROM control signal (data)
50	GND	-	GND

6.2.2 Carriage relay PCB

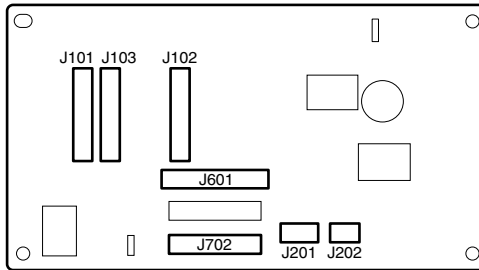

F-6-2

T-6-21

J101			
Pin Number	Signal name	IN/OUT	Function
1	VMGND	-	GND
2	VMGND	-	GND
3	VMGND	-	GND
4	VMGND	-	GND
5	VM	OUT	Power supply (+32V)
6	VM	OUT	Power supply (+32V)
7	VM	OUT	Power supply (+32V)
8	VM	OUT	Power supply (+32V)
9	VM	OUT	Power supply (+32V)
10	VM	OUT	Power supply (+32V)
11	VM	OUT	Power supply (+32V)
12	VM	OUT	Power supply (+32V)
13	SNS5V	OUT	Power supply (+5V)
14	SNS5V	OUT	Power supply (+5V)
15	GND	-	GND
16	+3.3V	OUT	Power supply (+3.3V)
17	+3.3V	OUT	Power supply (+3.3V)
18	GND	-	GND
19	VH_MONI2	IN	VH control signal 2
20	VH_ENB	OUT	VH power supply ON/OFF signal
21	VH_MONI1	IN	VH control signal 1
22	VMGND	-	GND
23	VMGND	-	GND
24	VMGND	-	GND
25	VMGND	-	GND

T-6-22

J102			
Pin Number	Signal name	IN/OUT	Function
1	GND	-	GND
2	H1-D-DATA-7-OD_B	OUT	Odd head data signal 7(D)
3	GND	-	GND
4	H1-E-HE-8_B	OUT	Head heat enable signal 8(E)
5	GND	-	GND
6	H1-E-DATA-8-EV_B	OUT	Even head data signal 8(E)
7	GND	-	GND
8	H1-F-DATA-10-OD_B	OUT	Odd head data signal 10(F)
9	GND	-	GND
10	H1-E-DATA-9-OD_B	OUT	Odd head data signal 9(E)
11	GND	-	GND
12	H1-F-HE-10_B	OUT	Head heat enable signal 10(F)
13	GND	-	GND
14	H1-F-DATA-11-OD_B	OUT	Odd head data signal 11(F)
15	GND	-	GND
16	H1-F-HE-11_B	OUT	Head heat enable signal 11(F)
17	GND	-	GND
18	H1-F-DATA-11-EV_B	OUT	Even head data signal 11(F)
19	GND	-	GND
20	H1-F-DATA-10-EV_B	OUT	Even head data signal 10(F)
21	GND	-	GND
22	H1-E-HE-9_B	OUT	Head heat enable signal 9(E)
23	GND	-	GND
24	H1-E-DATA-9-EV_B	OUT	Even head data signal 9(E)
25	GND	-	GND
26	H1-B-DATA-2-OD_B	OUT	Odd head data signal 2(B)
27	GND	-	GND
28	H1-B-DATA-3-OD_B	OUT	Odd head data signal 3(B)
29	GND	-	GND
30	H1-C-HE-4_B	OUT	Head heat enable signal 4(C)
31	GND	-	GND
32	H1-C-DATA-4-OD_B	OUT	Odd head data signal 4(C)
33	GND	-	GND
34	H1-B-HE-2_B	OUT	Head heat enable signal 2(B)
35	GND	-	GND
36	H1-A-DATA-1-OD_B	OUT	Odd head data signal 1(A)
37	GND	-	GND
38	H1-A-DATA-0-OD_B	OUT	Odd head data signal 0(A)
39	GND	-	GND

J102			
Pin Number	Signal name	IN/OUT	Function
40	PWLED2_ON	OUT	Multi sensor LED2 drive signal
41	PWLED3_ON	OUT	Multi sensor LED3 drive signal
42	PWLED1_ON	OUT	Multi sensor LED1 drive signal
43	PWLED4_ON	OUT	Multi sensor LED4 drive signal
44	/CR_COVER	IN	Carriage cover sensor output signal
45	VH_DIS	OUT	VH selection signal
46	/OUT_ENB	OUT	Head data enable signal
47	/H3V_ON_B	OUT	Power supply (+3V)
48	MLT_SENS_1IN	IN	Multi sensor signal 1
49	MLT_SENS_2IN	IN	Multi sensor signal 2
50	GND	-	GND

T-6-23

J103			
Pin Number	Signal name	IN/OUT	Function
1	GND	-	GND
2	H1-E-DATA-8-OD_B	OUT	Odd head data signal 8(E)
3	GND	-	GND
4	H1-D-HE-7_B	OUT	Head heat enable signal 7(D)
5	GND	-	GND
6	H1-D-DATA-7-EV_B	OUT	Even head data signal 7(D)
7	GND	-	GND
8	H1-D-DATA-6-EV_B	OUT	Even head data signal 6(D)
9	GND	-	GND
10	H1-D-DATA-6-OD_B	OUT	Odd head data signal 6(D)
11	GND	-	GND
12	H1-D-HE-6_B	OUT	Head heat enable signal 6(D)
13	GND	-	GND
14	H1-C-HE-5_B	OUT	Head heat enable signal 5(C)
15	GND	-	GND
16	H1-C-DATA-5-OD_B	OUT	Odd head data signal 5(C)
17	GND	-	GND
18	H1_CLK_B	OUT	Head clock signal
19	GND	-	GND
20	/H1_LT_B	OUT	Head latch signal
21	GND	-	GND
22	H1-C-DATA-5-EV_B	OUT	Even head data signal 5(C)
23	GND	-	GND

J103			
Pin Number	Signal name	IN/OUT	Function
24	H1-B-HE-3_B	OUT	Head heat enable signal 3(B)
25	GND	-	GND
26	H1-C-DATA-4-EV_B	OUT	Even head data signal 4(C)
27	GND	-	GND
28	H1-B-DATA-3-EV_B	OUT	Even head data signal 3(B)
29	GND	-	GND
30	H1-B-DATA-2-EV_B	OUT	Even head data signal 2(B)
31	GND	-	GND
32	H1-A-DATA-1-EV_B	OUT	Even head data signal 1(A)
33	GND	-	GND
34	H1-A-HE-1_B	OUT	Head heat enable signal 1(A)
35	GND	-	GND
36	H1-A-DATA-0-EV_B	OUT	Even head data signal 0(A)
37	GND	-	GND
38	H1-A-HE-0_B	OUT	Head heat enable signal 0(A)
39	GND	-	GND
40	/ENCODER_A	IN	Carriage encoder output signal A
41	/ENCODER_B	IN	Carriage encoder output signal B
42	H-DASH_LICC2_B	OUT	Head analogue switch A/D trigger signal
43	H1-DASLK_LICC2	OUT	Head analogue switch clock signal
44	H1-DLD_LICC2	OUT	Head analogue switch latch signal
45	H1-DATA_LICC2	OUT	Head analogue switch data signal
46	H1-DSOUT2	IN	Head temperature output signal 2
47	H1-DSOUT1	IN	Head temperature output signal 1
48	IO_ASIC_SCL_B	IN/OUT	Head ROM control signal (clock)
49	IO_ASIC_SDA	IN/OUT	Head ROM control signal (data)
50	GND	-	GND

T-6-24

J201			
Pin Number	Signal name	IN/OUT	Function
1	/CRENCA	IN	Linear encoder output signal A
2	SNS5V	OUT	Power supply (+5V)
3	/CRENCB	IN	Linear encoder output signal B
4	GND	-	GND
5	N.C	-	N.C

T-6-25

J202			
Pin Number	Signal name	IN/OUT	Function
1	+3.3V	OUT	Power supply (+3.3V)
2	GND	-	GND
3	/CR_COVER	IN	Carriage cover sensor output signal

T-6-26

J601			
Pin Number	Signal name	IN/OUT	Function
1	GND	-	GND
2	VHT	OUT	Head transistor drive power supply
3	VH_FB	OUT	VH feed back voltage +
4	VH2	OUT	Power supply
5	VH2	OUT	Power supply
6	VH2	OUT	Power supply
7	VH2	OUT	Power supply
8	VH2	OUT	Power supply
9	VH2	OUT	Power supply
10	VMGND	-	GND
11	VMGND	-	GND
12	VMGND	-	GND
13	VMGND	-	GND
14	VMGND	-	GND
15	VH1	OUT	Power supply
16	VH1	OUT	Power supply
17	VH1	OUT	Power supply
18	VH1	OUT	Power supply
19	VH1	OUT	Power supply
20	VH1	OUT	Power supply
21	VH1_FB	OUT	VH feed back voltage -
22	GND	-	GND
23	GND	-	GND
24	H3V	OUT	Power supply (+3V)
25	GND	-	GND
26	PWLED4	OUT	Multi sensor LED 4 drive signal
27	PWLED3	OUT	Multi sensor LED 3 drive signal
28	PWLED2	OUT	Multi sensor LED 2 drive signal
29	PWLED1	OUT	Multi sensor LED 1 drive signal
30	VMGND	-	GND

T-6-27

J702			
Pin Number	Signal name	IN/OUT	Function
1	MLT_SNS_2IN	IN	Multi sensor signal 2
2	MLT_SNS_1IN	IN	Multi sensor signal 1
3	H1-C-DATA-4-OD	OUT	Odd head data signal 4(C)
4	/H1-C-HE-4	OUT	Head heat enable signal 4(C)
5	H1-B-DATA-3-OD	OUT	Odd head data signal 3(B)
6	H1-B-DATA-2-OD	OUT	Odd head data signal 2(B)
7	/H1-B-HE-2	OUT	Head heat enable signal 2(B)
8	H1-A-DATA-1-OD	OUT	Odd head data signal 1(A)
9	H1-A-DATA-0-OD	OUT	Odd head data signal 0(A)
10	/H1-A-HE-0	OUT	Head heat enable signal 0(A)
11	H1-A-DATA-0-EV	OUT	Even head data signal 0(A)
12	H1-A-DATA-1-EV	OUT	Even head data signal 1(A)
13	/H1-A-HE-1	OUT	Head heat enable signal 1(A)
14	H1-B-DATA-2-EV	OUT	Even head data signal 2(B)
15	H1-B-DATA-3-EV	OUT	Even head data signal 3(B)
16	/H1-B-HE-3	OUT	Head heat enable signal 3(B)
17	H1-C-DATA-4-EV	OUT	Even head data signal 4(C)
18	/H1_LT	OUT	Head latch signal
19	H1-C-DATA-5-EV	OUT	Even head data signal 5(C)
20	/H1-C-HE-5	OUT	Head heat enable signal 5(C)
21	H1-C-DATA-5-OD	OUT	Odd head data signal 5(C)
22	H1_CLK	OUT	Head clock signal
23	H1-D-DATA-7-OD	OUT	Odd head data signal 7(D)
24	H1-D-DATA-6-OD	OUT	Odd head data signal 6(D)
25	/H1-D-HE-6	OUT	Head heat enable signal 6(D)
26	H1-D-DATA-6-EV	OUT	Even head data signal 6(D)
27	H1-D-DATA-7-EV	OUT	Even head data signal 7(D)
28	/H1-D-HE-7	OUT	Head heat enable signal 7(D)
29	H1-E-DATA-8-EV	OUT	Even head data signal 8(E)
30	H1-E-DATA-9-EV	OUT	Even head data signal 9(E)
31	/H1-E-HE-9	OUT	Head heat enable signal 9(E)
32	H1-F-DATA-10-EV	OUT	Even head data signal 10(F)
33	H1-F-DATA-11-EV	OUT	Even head data signal 11(F)
34	/H1-F-HE-11	OUT	Head heat enable signal 11(F)
35	H1-F-DATA-11-OD	OUT	Odd head data signal 11(F)
36	H1-F-DATA-10-OD	OUT	Odd head data signal 10(F)
37	/H1-F-HE-10	OUT	Head heat enable signal 10(F)
38	H1-E-DATA-9-OD	OUT	Odd head data signal 9(E)
39	H1-E-DATA-8-OD	OUT	Odd head data signal 8(E)

J702			
Pin Number	Signal name	IN/OUT	Function
40	/H1-E-HE-8	OUT	Head heat enable signal 8(E)
41	GND	-	GND
42	H1_DSOUT1	IN	Head temperature output signal 1
43	H1_DSOUT2	IN	Head temperature output signal 2
44	H1-DLD_LICC2	OUT	Head analogue switch latch signal
45	H1-DATA-LICC2	OUT	Head analogue switch data signal
46	H1-DASLK_LICC2	OUT	Head analogue switch clock signal
47	H1-DASH_LICC2	OUT	Head analogue switch A/D trigger signal
48	SNS5V	OUT	Power supply (+5V)
49	IO-ASIC_SDA	IN/OUT	Head ROM control signal (data)
50	IO-ASIC_SCL	IN/OUT	Head ROM control signal (clock)

6.2.3 Head relay PCB

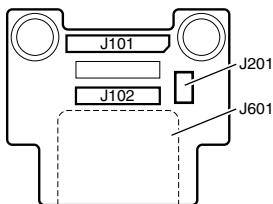

F-6-3

T-6-28

J101			
Pin Number	Signal name	IN/OUT	Function
1	VMGND	-	GND
2	PWLED1	IN	Multi sensor LED1 drive signal
3	PWLED2	IN	Multi sensor LED2 drive signal
4	PWLED3	IN	Multi sensor LED3 drive signal
5	PWLED4	IN	Multi sensor LED4 drive signal
6	VMGND	-	GND
7	H3V	IN	Power supply (+3V)
8	GND	-	GND
9	GND	-	GND
10	VH1_FB	IN	VH feed back voltage -
11	VH1	IN	Power supply
12	VH1	IN	Power supply
13	VH1	IN	Power supply
14	VH1	IN	Power supply
15	VH1	IN	Power supply
16	VH1	IN	Power supply
17	VMGND	-	GND
18	VMGND	-	GND
19	VMGND	-	GND
20	VMGND	-	GND
21	VMGND	-	GND
22	VH2	IN	Power supply
23	VH2	IN	Power supply
24	VH2	IN	Power supply
25	VH2	IN	Power supply
26	VH2	IN	Power supply
27	VH2	IN	Power supply
28	VH_FB	IN	VH feed back voltage +

J101			
Pin Number	Signal name	IN/OUT	Function
29	VHT	IN	Head transistor drive power supply
30	GND	-	GND

T-6-29

J102			
Pin Number	Signal name	IN/OUT	Function
1	IO-ASIC_SCL	IN/OUT	Head ROM control signal (clock)
2	IO-ASIC_SDA	IN/OUT	Head ROM control signal (data)
3	SNS5V	IN	Power supply (+5V)
4	H1-DASH_LICC2	IN	Head analogue switch A/D trigger signal
5	H1-DASLK_LICC2	IN	Head analogue switch clock signal
6	H1-DATA-LICC2	IN	Head analogue switch data signal
7	H1-DLD_LICC2	IN	Head analogue switch latch signal
8	H1_DSOUT2	OUT	Head temperature output signal 2
9	H1_DSOUT1	OUT	Head temperature output signal 1
10	GND	-	GND
11	/H1-E-HE-8	IN	Head heat enable signal 8(E)
12	H1-E-DATA-8-OD	IN	Odd head data signal 8(E)
13	H1-E-DATA-9-OD	IN	Odd head data signal 9(E)
14	/H1-F-HE-10	IN	Head heat enable signal 10(F)
15	H1-F-DATA-10-OD	IN	Odd head data signal 10(F)
16	H1-F-DATA-11-OD	IN	Odd head data signal 11(F)
17	/H1-F-HE-11	IN	Head heat enable signal 11(F)
18	H1-F-DATA-11-EV	IN	Even head data signal 11(F)
19	H1-F-DATA-10-EV	IN	Even head data signal 10(F)
20	/H1-E-HE-9	IN	Head heat enable signal 9(E)
21	H1-E-DATA-9-EV	IN	Even head data signal 9(E)
22	H1-E-DATA-8-EV	IN	Even head data signal 8(E)
23	/H1-D-HE-7	IN	Head heat enable signal 7(D)
24	H1-D-DATA-7-EV	IN	Even head data signal 7(D)
25	H1-D-DATA-6-EV	IN	Even head data signal 6(D)
26	/H1-D-HE-6	IN	Head heat enable signal 6(D)
27	H1-D-DATA-6-OD	IN	Odd head data signal 6(D)
28	H1-D-DATA-7-OD	IN	Odd head data signal 7(D)
29	H1_CLK	IN	Head clock signal
30	H1-C-DATA-5-OD	IN	Odd head data signal 5(C)
31	/H1-C-HE-5	IN	Head heat enable signal 5(C)
32	H1-C-DATA-5-EV	IN	Even head data signal 5(C)
33	/H1_LT	IN	Head latch signal
34	H1-C-DATA-4-EV	IN	Even head data signal 4(C)

J102			
Pin Number	Signal name	IN/OUT	Function
35	/H1-B-HE-3	IN	Head heat enable signal 3(B)
36	H1-B-DATA-3-EV	IN	Even head data signal 3(B)
37	H1-B-DATA-2-EV	IN	Even head data signal 2(B)
38	/H1-A-HE-1	IN	Head heat enable signal 1(A)
39	H1-A-DATA-1-EV	IN	Even head data signal 1(A)
40	H1-A-DATA-0-EV	IN	Even head data signal 0(A)
41	/H1-A-HE-0	IN	Head heat enable signal 0(A)
42	H1-A-DATA-0-OD	IN	Odd head data signal 0(A)
43	H1-A-DATA-1-OD	IN	Odd head data signal 1(A)
44	/H1-B-HE-2	IN	Head heat enable signal 2(B)
45	H1-B-DATA-2-OD	IN	Odd head data signal 2(B)
46	H1-B-DATA-3-OD	IN	Odd head data signal 3(B)
47	/H1-C-HE-4	IN	Head heat enable signal 4(C)
48	H1-C-DATA-4-OD	IN	Odd head data signal 4(C)
49	MLT_SNS_IIN	OUT	Multi sensor signal 1
50	MLT_SNS_2IN	OUT	Multi sensor signal 2

T-6-30

J201			
Pin Number	Signal name	IN/OUT	Function
1	PWLED1	OUT	Multi sensor LED1 drive signal
2	PWLED2	OUT	Multi sensor LED2 drive signal
3	PWLED3	OUT	Multi sensor LED3 drive signal
4	PWLED4	OUT	Multi sensor LED4 drive signal
5	GND	-	GND
6	MLT_SNS_1	IN	Multi sensor signal 1
7	MLT_SNS_2	IN	Multi sensor signal 2
8	+5V	OUT	Power supply (+5V)

T-6-31

J601			
Pin Number	Signal name	IN/OUT	Function
1	VH2	OUT	Power supply
2	VH2	OUT	Power supply
3	VH2	OUT	Power supply
4	VHT12	OUT	Head transistor drive power supply
5	H1-F-DATA-10-EV	OUT	Even head data signal 10(F)
6	IO_ASIC_SDA	IN/OUT	Head ROM control signal (data)
7	IO_ASIC_SCL	IN/OUT	Head ROM control signal (clock)

J601			
Pin Number	Signal name	IN/OUT	Function
8	H3V_1	OUT	Power supply (+3V)
9	H1-C-DIA1	IN	Head DI sensor signal 1(C)
10	/H1-A-HE-1	OUT	Head heat enable signal 1(A)
11	VH1	OUT	Power supply
12	VH1	OUT	Power supply
13	VH1	OUT	Power supply
14	VH2	OUT	Power supply
15	VH2	OUT	Power supply
16	H1-E-DATA-9-OD	OUT	Odd head data signal 9(E)
17	/H1-F-HE-11	OUT	Head heat enable signal 11(F)
18	H1-E-DIA1	IN	Head DI sensor signal 1(E)
19	H1-D-DIA1	IN	Head DI sensor signal 1(D)
20	H3V_1	OUT	Power supply (+3V)
21	H3V_1	OUT	Power supply (+3V)
22	H1-B-DATA-3-EV	OUT	Even head data signal 3(B)
23	H1-A-DATA-0-EV	OUT	Even head data signal 0(A)
24	/H1-B-HE-2	OUT	Head heat enable signal 2(B)
25	VH1	OUT	Power supply
26	VH1	OUT	Power supply
27	H1-D-DIA2	IN	Head DI sensor signal 2(D)
28	/H1-E-HE-8	OUT	Head heat enable signal 8(E)
29	H1-E-DIA2	IN	Head DI sensor signal 2(E)
30	H1-F-DIA2	IN	Head DI sensor signal 2(F)
31	/H1-E-HE-9	OUT	Head heat enable signal 9(E)
32	H1-D-DATA-7-EV	OUT	Even head data signal 7(D)
33	H1-D-HE-6	OUT	Head heat enable signal 6(D)
34	H1-C-DATA-5-OD	OUT	Odd head data signal 5(C)
35	H1-C-DATA-4-EV	OUT	Even head data signal 4(C)
36	H1-A-DATA-1-EV	OUT	Even head data signal 1(A)
37	H1-A-DIA2	IN	Head DI sensor signal 2(A)
38	H1-B-DIA2	IN	Head DI sensor signal 2(B)
39	/H1-C-HE-4	OUT	Head heat enable signal 4(C)
40	H1-D-DATA-7-OD	OUT	Odd head data signal 7(D)
41	H1-E-DATA-8-OD	OUT	Odd head data signal 8(E)
42	/H1-F-HE-10	OUT	Head heat enable signal 10(F)
43	H1-F-DATA-11-EV	OUT	Even head data signal 11(F)
44	H1-E-DATA-8-EV	OUT	Even head data signal 8(E)
45	H1-D-DATA-6-EV	OUT	Even head data signal 6(D)
46	H1-C-DIA2	IN	Head DI sensor signal 2(C)
47	H1-C-DATA-5-EV	OUT	Even head data signal 5(C)

J601			
Pin Number	Signal name	IN/OUT	Function
48	H1-B-DIA1	IN	Head DI sensor signal 1(B)
49	/H1-A-HE-0	OUT	Head heat enable signal 0(A)
50	H1-B-DATA-2-OD	OUT	Odd head data signal 2(B)
51	H1-B-DATA-3-OD	OUT	Odd head data signal 3(B)
52	H1-C-DATA-4-OD	OUT	Odd head data signal 4(C)
53	GND	-	GND
54	GND	-	GND
55	GND	-	GND
56	H1-F-DATA-11-OD	OUT	Odd head data signal 11(F)
57	H1-E-DATA-9-EV	OUT	Even head data signal 9(E)
58	GND	-	GND
59	H1-D-DATA-6-OD	OUT	Odd head data signal 6(D)
60	/H1-C-HE-5	OUT	Head heat enable signal 5(C)
61	/H1-B-HE-3	OUT	Head heat enable signal 3(B)
62	H1-A-DIA1	IN	Head DI sensor signal 1(A)
63	H1-A-DATA-1-OD	OUT	Odd head data signal 1(A)
64	GND	-	GND
65	GND	-	GND
66	GND	-	GND
67	GND	-	GND
68	H1-F-DATA-10-OD	OUT	Odd head data signal 10(F)
69	H1-F-DIA1	IN	Head DI sensor signal 1(F)
70	/H1-D-HE-7	OUT	Head heat enable signal 7(D)
71	GND	-	GND
72	H1_CLK	OUT	Head clock signal
73	/H1_LT	OUT	Head latch signal
74	H1-B-DATA-2-EV	OUT	Even head data signal 2(B)
75	H1-A-DATA-0-OD	OUT	Odd head data signal 0(A)
76	GND	-	GND
77	GND	-	GND
78	GND	-	GND

6.3 Version Up

6.3.1 Firmware Update Tool

Use of the following tools allows you to update the firmware of the main controller incorporated in the printer.

- GARO Firmware Update Tool
- L Printer Service Tool

1. GARO Firmware Update Tool

GARO Firmware Update Tool is the same as that for user.

Procedure:

- 1) Start CARO Firmware Update Tool.
- 2) Place the printer in the online mode.
- 3) Transfer the firmware data to the printer according to the instructions shown on the display.
- 4) The data shown on the LCD on the operation panel changes and the firmware is updated automatically.
- 5) When firmware update is completed, the printer will start again.

File transfer route:

USB, IEEE1394, network

2. L Printer Service Tool

Procedure:

- 1) Start L Printer Service Tool.
- 2) Place the printer in the online mode.
- 3) Specify the firmware file(jdl) and then transfer it.
- 4) The data shown on the LCD on the operation panel changes and the firmware is updated automatically.
- 5) When firmware update is completed, the printer will start again.

File transfer route:

USB, IEEE1394, network

6.4 Service Tools

6.4.1 Tool List

T-6-32

General-purpose tools	Application
Long phillips screwdriver	Inserting and removing screw
Phillips screwdriver	Inserting and removing screw
Flat-head screwdriver	Removing the E-ring
Needle-nose pliers	Inserting and removing the spring parts
Hex key wrench	Inserting and removing hexagonal screws
Flat brush	Applying grease
Lint free paper	Wiping off ink
Rubber gloves	Preventing ink stains

T-6-33

Special-purpose tools	Application
Grease MOLYKOTE PG-641 (CK-0562-000)	Applying to specified locations
Grease PERMALUBE G-2 (CK-0551-020)	Applying to specified locations
Cover Switch Tool (QY9-0103-000)	Pressing the cover switch

6.4.2 Using the Cover Switch Tool

Use the cover switch tool [1] by inserting the hook into the cover switch.

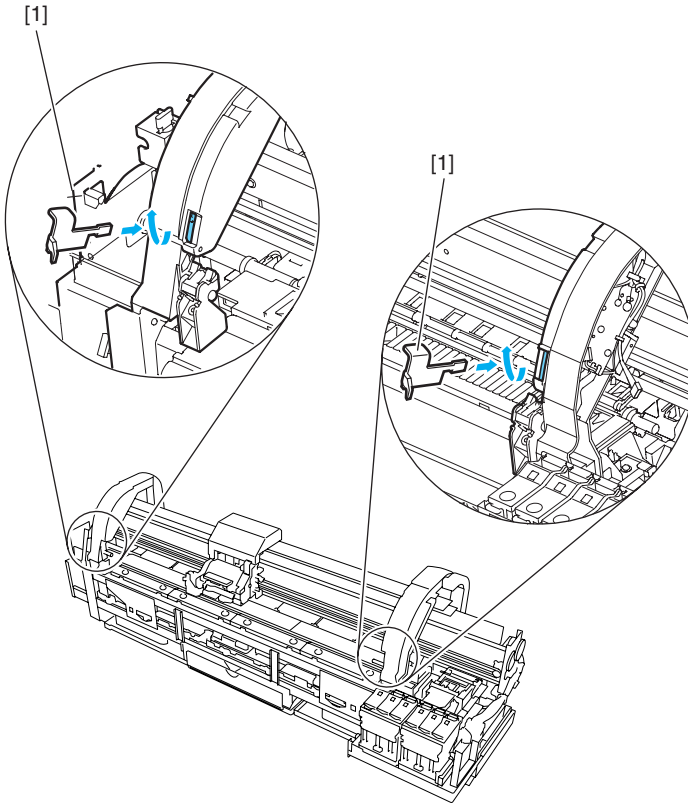

F-6-4

Chapter 7 SERVICE MODE

Contents

7.1 Service Mode	7-1
7.1.1 Service Mode Operation	7-1
7.1.2 Map of the Service Mode	7-2
7.1.3 Details of Service Mode	7-10
7.1.4 Sample Printout	7-27
7.2 Special Mode	7-32
7.2.1 Special Modes for Servicing	7-32

7.1 Service Mode

7.1.1 Service Mode Operation

a) How to enter the Service mode

Enter the Service mode following the procedure below.

- 1) Turn off the printer.
- 2) Turn on the printer while holding down the [Paper Source] button and [Information] button.
* Keep pressing the above buttons until "Initializing" appears on the display.
- 3) "S" is displayed in the upper right corner of the display showing the version.
- 4) After display of "Online", pressing the [Menu] button displays the SERVICE MODE top menu and the MESSAGE LED flashes.

* The Service mode is added to the options in the Main menu. The Service mode can be entered even in the error status (when an error message is shown on the display) by turning the power off and then using the above key operation.

b) How to exit the Service mode

Turn off the printer.

c) Key operation in the service mode

- Selecting menus and parameters: [◀] or [▶] button
- Going to the next lower-level menu: [▼] button
- Going to the next higher-level menu: [▲] key
- Determining a selected menu or parameter: [OK] button

7.1.2 Map of the Service Mode

The hierarchy of menus and parameters in the Service mode is shown below.

T-7-1

First Level	Second Level	Third Level	Fourth Level	Fifth Level
DISPLAY	PRINTINF SYSTEM	YES/NO	: Select YES to execute print	
		S/N		
		TYPE		
		LF TYPE		
		TMP		
		SIZE LF		
		SIZE LF		
		SIZE CR		
		SIZE CR		
	HEAD	S/N		
		LOT		
	INK	C		

		BK		
	WARNING	1		

		20		
	ERROR	1		

20				
INK CHECK	000000			
I/O DISPLAY	I/O DISPLAY 1			
	I/O DISPLAY 2			
ADJUST	PRINT PATTERN	NOZZLE 1	: Press the [OK] button to execute	
		NOZZLE 2	: Press the [OK] button to execute	
		NOZZLE 3	: Press the [OK] button to execute	
		OPTICAL AXIS	: Press the [OK] button to execute	
		LF TUNING	: Press the [OK] button to execute	

First Level	Second Level	Third Level	Fourth Level	Fifth Level		
		LF TUNING 2	: Press the [OK] button to execute			
		SENSOR CHECK				
	HEAD ADJ.	MANUAL HEAD ADJ	DETAIL	: Press the [OK] button to execute		
			BASIC	: Press the [OK] button to execute		
		ADJ. SETTING	A	A-1	: Adjustme nt value entry	

				A-24	: Adjustme nt value entry	

				F	F-1	: Adjustme nt value entry
			SAVE SETTINGS	YES/NO		
			RESET SETTINGS	YES/NO		
		NOZZLE CHK POS.	YES/NO			
	GAP CALIB.	YES/NO				
	CHANGE LF TYPE	0/1				
REPLACE	CUTTER	YES/NO				

T-7-2

First Level	Second Level	Third Level	Fourth Level	Fifth Level
COUNTER	PRINTER	LIFE TTL		
		LIFE ROLL		
		LIFE CUTSHEET		
		LIFE A		

		LIFE F		

First Level	Second Level	Third Level	Fourth Level	Fifth Level
		POWER ON		
		W-INK		
		CUTTER		
		WIPE		
	CARRIAGE	PRINT		
		CR COUNT		
		CR DIST.		
		PRINT COUNT		
	PURGE	CLN-A-1		
		CLN-A-2		
		CLN-A-3		
		CLN-A-6		
		CLN-A-7		
		CLN-A-10		
		CLN-A-11		
		CLN-A-15		
		CLN-A-16		
		CLN-A-17		
		CLN-A-TTL		
		CLN-M-1		
		CLN-M-4		
		CLN-M-5		
		CLN-M-6		
		CLN-M-TTL		
	CLEAR	CLR-INK CONSUME		
		CLR-CUTTER EXC.		
		CLR-MTC EXC.		
		CLR-HEAD EXC.		
		CLR-UNIT A EXC.		
		CLR-UNIT D EXC.		
		CLR-UNIT F EXC.		
		CLR-UNIT H EXC.		
		CLR-UNIT K EXC.		
CLR-UNIT M EXC.				
CLR-FACTORY CNT.				

T-7-3

First Level	Second Level	Third Level	Fourth Level	Fifth Level
COUNTER	EXCHANGE	CUTTER EXC.		
		MTC EXC.		
		HEAD EXC.		
		BOARD EXC.(M/B)		
		UNIT A EXC.		
		UNIT D EXC.		
		UNIT F EXC.		
		UNIT H EXC.		
		UNIT K EXC.		
		UNIT M EXC.		
		DETAIL-CNT	MOVE PRINTER	
	N-INK CHK(C)			

	N-INK CHK(BK)			
	MEDIACONFIG-CNT			
	INK-USE1	INK-USE1(C)		

		INK-USE1(BK)		
		INK-USE1(TTL)		
		N-INK-USE1(C)		

		N-INK-USE1(BK)		
		N-INK-USE1(TTL)		
	INK-USE2	INK-USE2(C)		

		INK-USE2(BK)		
		INK-USE2(TTL)		
		N-INK-USE2(C)		

		N-INK-USE2(BK)		
	N-INK-USE2(TTL)			
	INK-EXC	INK-EXC(C)		

		INK-EXC(BK)		
		INK-EXC(TTL)		
		N-INK-EXC(C)		

First Level	Second Level	Third Level	Fourth Level	Fifth Level
		N-INK-EXC(BK)		
		N-INK-EXC(TTL)		

T-7-4

First Level	Second Level	Third Level	Fourth Level	Fifth Level
COUNTER	MEDIA 1	NAME		
		TTL		
		TTL		
		ROLL		
		ROLL		
		CUTSHEET		
		CUTSHEET		

	MEDIA 7	NAME		
		TTL		
		TTL		
		ROLL		
		ROLL		
		CUTSHEET		
		CUTSHEET		
		MEDIA OTHER	NAME	
	TTL			
	TTL			
	ROLL			
	ROLL			
	CUTSHEET			
	CUTSHEET			
	MEDIASIZE1 ROLL		P-SQ 36-44	
		P-SQ 36-44		
		P-SQ 24-36		
		P-SQ 24-36		
		P-SQ 17-24		
		P-SQ 17-24		
		P-SQ -17		
		P-SQ -17		
		P-CNT 36-44		
		P-CNT 24-36		
		P-CNT 17-24		
P-CNT 17-24				

First Level	Second Level	Third Level	Fourth Level	Fifth Level	
		P-CNT -17			
	MEDIASIZE2 ROLL	D-SQ 36-44			
		D-SQ 36-44			
		D-SQ 24-36			
		D-SQ 24-36			
		D-SQ 17-24			
		D-SQ 17-24			
		D-SQ -17			
		D-SQ -17			
		D-CNT 36-44			
		D-CNT 24-36			
		D-CNT 17-24			
		D-CNT -17			
		MEDIASIZE1 CUT	P-SQ 36-44		
			P-SQ 36-44		
	P-SQ 24-36				
	P-SQ 24-36				
	P-SQ 17-24				
	P-SQ 17-24				
	P-SQ -17				
	P-SQ -17				
	P-CNT 36-44				
	P-CNT 24-36				
	P-CNT 17-24				
	P-CNT -17				

First Level	Second Level	Third Level	Fourth Level	Fifth Level		
COUNTER	MEDIASIZE2 CUT	D-SQ 36-44				
		D-SQ 36-44				
		D-SQ 24-36				
		D-SQ 24-36				
		D-SQ 17-24				
		D-SQ 17-24				
		D-SQ -17				
		D-SQ -17				
		D-CNT 36-44				
		D-CNT 24-36				
		D-CNT 17-24				
		D-CNT -17				
		HEAD DOT CNT. 1			C	

	BK					
	TTL					
	HEAD DOT CNT. 2	C				

		BK				
		TTL				
	PARTS CNT.	COUNTER A		OK/W1/W2/E		
				PARTS A1		1:00
						2:00
						3:00
						4:00

		COUNTER M			OK/W1/W2/E	
					PARTS M1	
					2:00	
					3:00	
					4:00	
SETTING	Pth	ON/OFF				
	RTC	DATE	XXXX/XX/XX	: Date entry		
		TIME	XX:XX	: Time entry		
	PV AUTO JUDGE	ON/PFF				

First Level	Second Level	Third Level	Fourth Level	Fifth Level	
INITIALIZE	WARNIG	: Press the [OK] button to clear			
	ERROR	: Press the [OK] button to clear			
	ADJUST	: Press the [OK] button to clear			
	W-INK	: Press the [OK] button to clear			
	PURGE	: Press the [OK] button to clear			
	INK-USE CNT	: Press the [OK] button to clear			
	CUTTER-CHG CNT	: Press the [OK] button to clear			
	W-INK-CHG CNT	: Press the [OK] button to clear			
	HEAD-CHG CNT	: Press the [OK] button to clear			
	PARTS-CHG CNT	PARTS A1		: Press the [OK] button to clear	

		PARTS M1		: Press the [OK] button to clear	
	PARTS COUNTER	PARTS A1		: Press the [OK] button to clear	

PARTS M1			: Press the [OK] button to clear		

7.1.3 Details of Service Mode

This section provides details of the Service mode menu.

a) DISPLAY

Displays and prints the printer information.

1) PRINF INF

Prints adjustment values in the User menu, [DISPLAY] and [COUNTER] parameters on A4-size or larger paper. When a roll media is used, the layout is optimized according to the media width.

2) SYSTEM

Displays the printer information shown below.

T-7-6

Display	Description	Unit
S/N	Serial number of printer	-
TYPE	Type setting on main controller PCB * iPF710/700 is represented by 36.	-
LF TYPE	Feed roller type: 0 or 1	-
TMP	Ambient temperature	degrees C
SIZE LF	Detected size of loaded media (feed direction) 0 is always detected for the roll media.	mm
SIZE LF	Detected size of loaded media (feed direction) 0 is always detected for the roll media.	inch
SIZE CR	Detected size of loaded media (carriage scan direction)	mm
SIZE CR	Detected size of loaded media (carriage scan direction)	inch

3) HEAD

Displays the following EEPROM information of the printhead.

T-7-7

Display	Description
S/N	Serial number of printhead
LOT	Lot number of printhead

4) INK

Displays the numbers of days passed since installation of the following ink tanks.

T-7-8

Display	Description	Unit
BK	Number of days passed since the BK ink tank was installed	Day(s))

Display	Description	Unit
MBK	Number of days passed since the MBK ink tank was installed	Day(s))
MBK2	Number of days passed since the MBK2 ink tank was installed	Day(s))
C	Number of days passed since the C ink tank was installed	Day(s))
M	Number of days passed since the M ink tank was installed	Day(s))
Y	Number of days passed since the Y ink tank was installed	Day(s))

5) WARNING

Displays the warning history (up to 20 events). The newest event has the smallest history number.

6) ERROR

Displays the error history (up to 20 events). The newest event has the smallest history number.

7) INK CHECK

Displays the history of execution of turning off the remaining ink level detection (by using the refilled ink tank) in the order of C, M, Y, MBK, MBK, BK.

0: No execution

1: Executed at least once

Display position	Sensor name	LCD display contents
13	(Not Used)	0
14	(Not Used)	0
15	(Not Used)	0
16	(Not Used)	0
17	(Not Used)	0
18	(Not Used)	0
19	(Not Used)	0
20	(Not Used)	0
21	(Not Used)	0
22	Lift Cam Sensor	0: Sensor ON , 1: Sensor OFF
23	Pressure Release Switch	0: Pinch Roller Unit open , 1: Pinch Roller Unit close
24	Media Sensor	0: Sensor ON , 1: Sensor OFF
25	(Not Used)	0
26	(Not Used)	0
27	(Not Used)	0
28	(Not Used)	0
29	(Not Used)	0
30	(Not Used)	0
31	(Not Used)	0
32	(Not Used)	0

e) ADJUST

Performs adjustments and prints the adjustment and check patterns necessary for adjusting the printer parts.

1) PRINT PATTERN

T-7-12

Display	Description
NOZZLE 1	Prints the nozzle check pattern by single direction/ single pass without using the non-discharging back up. It is used to check for the non-discharging nozzles. - Media size: A4 - Media type: any
NOZZLE 2	Print a 100% solid print pattern (used to check the ink reaction that cannot be checked with "NOZZLE 1") in the single path direction. Use this method when checking blocked nozzles. - Use paper with a height equal to or longer than that of A4-sized paper (in portrait orientation). - Any media type is acceptable.
NOZZLE 3	Print a 100% solid print pattern (used to check the ink reaction that cannot be checked with "NOZZLE 1") in the single path direction. Use this method when checking blocked nozzles. (The print drive control method is different from that for "NOZZLE 2".) - Use paper with a height equal to or longer than that of A4-sized paper (in portrait orientation). - Any media type is acceptable.
OPTICAL AXIS	Prints the pattern and adjusts the optical axis of the multi sensor. For details, refer to "Disassembly/Reassembly" > "Adjustment and Setup Items" > "Procedure after replacing the carriage unit or multi sensor". - Media type: photo glossy paper
LF TUNING	Carry out automatic correction of eccentricity of the feed roller. For more details, refer to "Disassembly/Reassembly" > "Adjustment and Setup Items" > "Procedure after replacing the feed roller and reed roller encoder". - The media type is "gloss photo paper".
LF TUNING 2	Carry out manual correction of eccentricity of the feed roller. For more details, refer to "Disassembly/Reassembly" > "Adjustment and Setup Items" > "Procedure after replacing the feed roller and reed roller encoder". - The media type is "gloss photo paper".
SENSOR CHECK	* For Factory



SENSOR CHECK are intended for factory adjustment purposes.
No adjustment by service personnel is required.

2) HEAD ADJ.

Set or initialize the registration adjustment values of each printheads.

T-7-13

Display		Description
MANUAL HEAD ADJ	DETAIL	Prints the detail patterns for the manual head adjustment. After printing, the mode will change to [ADJ. SETTING]. Check the printed patterns and input the set values.
	BASIC	Prints the basic patterns for the manual head adjustment. After printing, the mode will change to [ADJ. SETTING]. Check the printed patterns and input the set values.
ADJ. SETTING	A to F	This mode is to input the registration adjustment values. It is possible to return the values to the former one by printing the status print before changing the value.
	A-1 to F-1	
	SAVE SETTINGS	Save the registration adjustment values that has been input.
RESET SETTINGS		Initialize the registration adjustment values (to 0).

3) NOZZLE CHK POS.

This mode for adjusting the optical axis of the head management sensor. For details, refer to "Disassembly/Reassembly" > "Adjustment and Setup Items" > "Procedure after replacing the head management sensor".

4) GAP CLIB.

This mode measures the gap between the printhead and media by multi sensor and corrects the calibration value.

5) CHANGE LF TYPE

Change the type of the feed roller.

0: Old feed roller

1: New feed roller

d) REPLACE

1) CUTTER

This mode is for replacing the cutter unit.

e) COUNTER

Displays the life (operation frequency and time) of each unit, print counts for each media type, and else. The count values can be printed from [PRINT INF].

1) PRINTER: Counters related to product life

T-7-14

Display	Description	Unit
LIFE TTL	Cumulative number of printed media (equivalent of A4)	sheets
LIFE ROLL	Cumulative number of printed roll media (equivalent of A4)	sheets
LIFE CUTSHEET	Cumulative number of printed cut sheets (equivalent to A4)	sheets
LIFE A-F	Cumulative number of printed media for environments A to F	sheets
POWER ON	Cumulative power-on time (excluding the sleep time)	Hours
W-INK	Remaining capacity of the maintenance cartridge	%
CUTTER	Number of cutting operations (count as 1 by moving back and forth)	Times
WIPE	Number of wiping operations	Times

2) CARRIAGE: Counters related to carriage unit

T-7-15

Display	Description	Unit
PRINT	Cumulative printing time	Hours
CR COUNT	Cumulative carriage scan count (count as 1 by moving back and forth)	Times
CR DIST.	Cumulative carriage scan distance (count as 1 by moving 210mm)	Times
PRINT COUNT	Cumulative print end count (count as 1 by capping)	Times

3) PURGE: Counters related to purge unit

T-7-16

Display	Description	Unit
CLN-A-1	Cumulative number of automatic cleaning 1 (normal suction) operations	Times
CLN-A-2	Cumulative number of automatic cleaning 2 (ink level adjusting) operations	Times
CLN-A-3	Cumulative number of automatic cleaning 3 (initial filling) operations	Times
CLN-A-6	Cumulative number of automatic cleaning 6 (strong normal suction) operations	Times
CLN-A-7	Cumulative number of automatic cleaning 7 (aging) operations	
CLN-A-10	Cumulative number of automatic cleaning 10 (ink filling after secondary transportation) operations	Times
CLN-A-11	Cumulative number of automatic cleaning 11 (ink filling after head replacement) operations	Times
CLN-A-15	Cumulative number of automatic cleaning 15 (dot count small suction) operations	Times
CLN-A-16	Cumulative number of automatic cleaning 16 (sedimented ink agitation) operations	Times
CLN-A-17	Cumulative number of automatic cleaning 17 (small suction) operations	Times
CLN-A-TTL	Total number of automatic cleaning operations	Times
CLN-M-1	Cumulative number of manual cleaning 1 (normal suction) operations	Times
CLN-M-4	Cumulative number of manual cleaning 4 (ink draining from head after head replacement) operations	Times
CLN-M-5	Cumulative number of manual cleaning 5 (ink draining from head and tube before transportation) operations	Times
CLN-M-6	Cumulative number of manual cleaning 6 (normal strong suction) operations	Times
CLN-M-TTL	Total number of manual cleaning operations	Times

4) CLEAR: Counters related to counter initialization

T-7-17

Display	Description	Unit
CLR-INK CONSUME	Cumulative count of ink section consumption amount clearing	Times
CLR-CUTTER EXC.	Cumulative count of cutter replacement count clearing	Times
CLR-MTC EXC.	Cumulative count of maintenance cartridge replacement count clearing	Times
CLR-HEAD EXC.	Cumulative count of printhead replacement count clearing	Times
CLR-UNIT A EXC.	Cumulative count of unit A(waste ink system) replacement count clearing	Times
CLR-UNIT D EXC.	Cumulative count of unit D(carriage unit) replacement count clearing	Times
CLR-UNIT F EXC.	Cumulative count of unit F(ink supply system) replacement count clearing	Times
CLR-UNIT H EXC.	Cumulative count of unit H(purge) replacement count clearing	Times
CLR-UNIT K EXC.	Cumulative count of unit K(head management sensor) replacement count clearing	Times
CLR-UNIT M EXC.	Cumulative count of unit M(carriage motor) replacement count clearing	Times
CLR-FACTORY CNT.	For factory	Times

5) EXCHANGE: Counters related to parts replacement

T-7-18

Display	Description	Unit
CUTTER EXC.	Cutter replacement count (Count of executing cutter replacement mode)	Times
MTC EXC.	Maintenance cartridge replacement count	Times
HEAD EXC.	Printhead replacement count	Times
BOARD EXC.(M/B)	Main controller PCB replacement count	Times
UNIT A EXC.	Unit A (waste ink system) replacement count (Count of executing [INITIALIZE] > [PARTS COUNTER] > [PARTS A])	Times
UNIT D EXC.	Unit D (carriage unit) replacement count (Count of executing [INITIALIZE] > [PARTS COUNTER] > [PARTS D])	Times
UNIT F EXC.	Unit F (ink supply system) replacement count (Count of executing [INITIALIZE] > [PARTS COUNTER] > [PARTS F])	Times
UNIT H EXC.	Unit H (purge unit) replacement count (Count of executing [INITIALIZE] > [PARTS COUNTER] > [PARTS H])	Times
UNIT K EXC.	Unit K (head management sensor) replacement count (Count of executing [INITIALIZE] > [PARTS COUNTER] > [PARTS K])	Times
UNIT M EXC.	Unit M (carriage unit) replacement count (Count of executing [INITIALIZE] > [PARTS COUNTER] > [PARTS M])	Times

6) DETAIL-CNT: Other counters

T-7-19

Display	Description	Unit
MOVE PRINTER	Count of [Move Printer] operations	Times
N-INKCHK(XX)	XX: Ink color Count of turning off the ink remaining level detection for each color	Times
MEDIACONFIG-CNT	Count of media registered by media editor	Times

7) INK-USE1: Counters related to ink consumption

T-7-20

Display	Description	Unit
INK-USE1(XX)	XX: Ink color Cumulative consumption amount of generic ink	ml
INK-USE1(TTL)	Total amount of the cumulative consumption of generic ink	ml
N-INK-USE1(XX)	XX: Ink color Cumulative consumption amount of refilled ink	ml
N-INK-USE1(TTL)	Total amount of the cumulative consumption of refilled ink	ml

8) INK-USE2: Counters related to ink consumption

T-7-21

Display	Description	Unit
INK-USE2(XX)	XX: Ink color Consumption amount of generic ink of the currently installed ink tank.	ml
INK-USE2(TTL)	Total consumption amount of generic ink of the currently installed ink tanks	ml
N-INK-USE2(XX)	XX: Ink color Consumption amount of refilled ink of the currently installed ink tank	ml
N-INK-USE2(TTL)	Total consumption amount of refilled ink of the currently installed ink tanks	ml

9) INK-EXC: Counters related to ink tank replacement

T-7-22

Display	Description	Unit
INK-EXC(XX)	XX: Ink color Cumulative count of generic ink tank replacement	ml
INK-EXC(TTL)	Total amount of the cumulative count of generic ink tank replacement	ml
N-INK-EXC(XX)	XX: Ink color Cumulative count of refilled ink tank replacement	ml
N-INK-EXC(TTL)	Total amount of the cumulative count of refilled ink tank replacement	ml

10) MEDIA x (x: 1 to 7): Counters related to media

One to seven media types are displayed individually in order with large cumulative print area.

T-7-23

Display	Description	Unit
NAME	Media type	-
TTL	Total amount of cumulative print area of roll media and cut sheet (metric)	m2
TTL	Total amount of cumulative print area of roll media and cut sheet (inch)	Sq.f
ROLL	Cumulative print area of roll media (metric)	m2
ROLL	Cumulative print area of roll media (inch)	Sq.f
CUT SHEET	Cumulative print area of cut sheet (metric)	m2
CUT SHEET	Cumulative print area of cut sheet (inch)	Sq.f

11) MEDIA OTHER: Counters related to media

Displays the total amount of cumulative print area of the other media type than the above-mentioned

T-7-24

Display	Description	Unit
NAME	Media type	-
TTL	Total amount of cumulative print area of roll media and cut sheet (metric)	m2
TTL	Total amount of cumulative print area of roll media and cut sheet (inch)	Sq.f
ROLL	Cumulative print area of roll media (metric)	m2
ROLL	Cumulative print area of roll media (inch)	Sq.f
CUT SHEET	Cumulative print area of cut sheet (metric)	m2
CUT SHEET	Cumulative print area of cut sheet (inch)	Sq.f

12) MEDIASIZE1 ROLL: Counters related to roll media printing

T-7-25

Display	Description	Unit
P-SQ 36-44	Cumulative print area of paper equal to or larger than 36 inches but less than 44 inches (physical size)	m2/Sq.f
P-SQ 24-36	Cumulative print area of paper equal to or larger than 24 inches but less than 36 inches (physical size)	m2/Sq.f
P-SQ 17-24	Cumulative print area of paper equal to or larger than 17 inches but less than 24 inches (physical size)	m2/Sq.f
P-SQ -17	Cumulative print area of paper less than 17 inches (physical size)	m2/Sq.f
P-CNT 36-44	Cumulative number of sheets of A4-equivalent paper equal to or larger than 36 inches but less than 44 inches (physical size)	sheets
P-CNT 24-36	Cumulative number of sheets of A4-equivalent paper equal to or larger than 24 inches but less than 36 inches (physical size)	sheets
P-CNT 17-24	Cumulative number of sheets of A4-equivalent paper equal to or larger than 17 inches but less than 24 inches (physical size)	sheets
P-CNT -17	Cumulative number of sheets of A4-equivalent paper less than 17 inches (physical size)	sheets

13) MEDIASIZE2 ROLL: Counters related to roll media printing

T-7-26

Display	Description	Unit
D-SQ 36-44	Cumulative print area of paper equal to or larger than 36 inches but less than 44 inches (data size)	m2/Sq.f
D-SQ 24-36	Cumulative print area of paper equal to or larger than 24 inches but less than 36 inches (data size)	m2/Sq.f
D-SQ 17-24	Cumulative print area of paper equal to or larger than 17 inches but less than 24 inches (data size)	m2/Sq.f
D-SQ -17	Cumulative print area of paper less than 17 inches (data size)	m2/Sq.f
D-CNT 36-44	Cumulative number of sheets of A4-equivalent paper equal to or larger than 36 inches but less than 44 inches (data size)	sheets
D-CNT 24-36	Cumulative number of sheets of A4-equivalent paper equal to or larger than 24 inches but less than 36 inches (data size)	sheets
D-CNT 17-24	Cumulative number of sheets of A4-equivalent paper equal to or larger than 17 inches but less than 24 inches (data size)	sheets
D-CNT -17	Cumulative number of sheets of A4-equivalent paper less than 17 inches (data size)	sheets

14) MEDIASIZE1 CUT: Counters related to cut sheet printing

T-7-27

Display	Description	Unit
P-SQ 36-44	Cumulative print area of paper equal to or larger than 36 inches but less than 44 inches (physical size)	m ² /Sq.f
P-SQ 24-36	Cumulative print area of paper equal to or larger than 24 inches but less than 36 inches (physical size)	m ² /Sq.f
P-SQ 17-24	Cumulative print area of paper equal to or larger than 17 inches but less than 24 inches (physical size)	m ² /Sq.f
P-SQ -17	Cumulative print area of paper less than 17 inches (physical size)	m ² /Sq.f
P-CNT 36-44	Cumulative number of sheets of A4-equivalent paper equal to or larger than 36 inches but less than 44 inches (physical size)	sheets
P-CNT 24-36	Cumulative number of sheets of A4-equivalent paper equal to or larger than 24 inches but less than 36 inches (physical size)	sheets
P-CNT 17-24	Cumulative number of sheets of A4-equivalent paper equal to or larger than 17 inches but less than 24 inches (physical size)	sheets
P-CNT -17	Cumulative number of sheets of A4-equivalent paper less than 17 inches (physical size)	sheets

15) MEDIASIZE2 CUT: Counters related to cut sheet printing

T-7-28

Display	Description	Unit
D-SQ 36-44	Cumulative print area of paper equal to or larger than 36 inches but less than 44 inches (data size)	m ² /Sq.f
D-SQ 24-36	Cumulative print area of paper equal to or larger than 24 inches but less than 36 inches (data size)	m ² /Sq.f
D-SQ 17-24	Cumulative print area of paper equal to or larger than 17 inches but less than 24 inches (data size)	m ² /Sq.f
D-SQ -17	Cumulative print area of paper less than 17 inches (data size)	m ² /Sq.f
D-CNT 36-44	Cumulative number of sheets of A4-equivalent paper equal to or larger than 36 inches but less than 44 inches (data size)	sheets
D-CNT 24-36	Cumulative number of sheets of A4-equivalent paper equal to or larger than 24 inches but less than 36 inches (data size)	sheets
D-CNT 17-24	Cumulative number of sheets of A4-equivalent paper equal to or larger than 17 inches but less than 24 inches (data size)	sheets
D-CNT -17	Cumulative number of sheets of A4-equivalent paper less than 17 inches (data size)	sheets

16) HEAD DOT CNT.1: Counter related to dot count

T-7-29

Display	Description	Unit
XX	XX: Ink color Dot counts of each colors of the currently installed printhead	(x 1,000,000) dots
TTL	Total dot counts of each colors of the currently installed printhead	(x 1,000,000) dots

17) HEAD DOT CNT.2: Counter related to dot count

T-7-30

Display	Description	Unit
XX	XX: Ink color Cumulative dot counts of each colors	(x 1,000,000) dots
TTL	Total cumulative dot counts of each colors	(x 1,000,000) dots

18) PARTS CNT. : Counter related to consumable parts

T-7-31

Display	Description	Unit
COUNTER x	x: Unit number of consumable parts (For detail, refer to "Maintenance and Inspection" > "Consumable Parts") Display the status and the days passed since the counter resetting. - Status OK: Use rate (until part replacement) of all consumable parts included in each unit are below 90%. W1: Use rate (until part replacement) of either of the consumable parts included in each unit has reached 90% or more. W2: Use rate (until part replacement) of either of the consumable parts included in each unit has reached 100%, but no need to stop the printer. E : Use rate (until part replacement) of either of the consumable parts included in each unit has reached 100%, and the printer needs to be stopped.	Day(s)
PARTS yy	1: yy: Unit number of consumable parts (For detail, refer to "Maintenance and Inspection" > "Consumable Parts") Counter of the consumable part (current)	
	2: Life of the consumable part	
	3: Use rate until part replacement	%
	4: Counter of the consumable part (accumulate)	

f) SETTING

Make various settings.

1) Pth

Turn on or off the head pulse rank control function.

Default: OFF

2) RTC

Set RTC (real time clock) after replacing the lithium battery on the main controller PCB.

T-7-32

Display		Description
DATE	yyyy/mm/dd	Set date
TIME	hh:mm	Set time

3) PV AUTO JUDGE

Sets ink saver mode.

Default: OFF

g) INITIALIZE

Clear the [DISPLAY] histories, [ADJUST] settings, [COUNTER] values, and other parameters.

T-7-33

Display	Description
WARNING	Initialize the history of WARNING. (All displayed contents of [DISPLAY] > [WARNING] will be initialized.)
ERROR	Initialize the history of ERROR. (All displayed contents of [DISPLAY] > [ERROR] will be initialized.)
ADJUST	Initialize the value of band adjustment (by user) and head adjustment. The automatically adjusted value will not be initialized.
W-INK	Initialize the remaining capacity (%) of the maintenance cartridge. (Clear [COUNTER] > [PRINTER] > [W-INK])
PURGE	Initialize the counter related to purge unit. (Clear [COUNTER] > [PURGE])
INK-USE CNT	Initialize the consumption amount of ink. (Clear [COUNTER] > [INK-USE2], and count up [COUNTER] > [CLEAR] > [CLR-INK CONSUME])
CUTTER-CHG CNT	Initialize the cutter unit replacement frequency. (Clear [COUNTER] > [EXCHANGE] > [CUTTER EXC.], and count up [COUNTER] > [CLEAR] > [CLR-CUTTER EXC.])
W-INK-CHG CNT	Initialize the maintenance cartridge replacement frequency. (Clear [COUNTER] > [EXCHANGE] > [MTC EXC.], and count up [COUNTER] > [CLEAR] > [CLR-MTC EXC.])
HEAD-CHG CNT	Initialize the printhead replacement frequency. (Clear [COUNTER] > [EXCHANGE] > [HEAD EXC.], and count up [COUNTER] > [CLEAR] > [CLR-HEAD EXC.])

Display		Description
PARTS- CHG CNT	PARTS xx	xx: Unit number of consumable parts (For details, refer to "Maintenance and Inspection" > "Consumable Parts") Initialize the consumable part replacement frequency. (Clear [COUNTER] > [EXCHANGE] > [UNIT x EXC], and count up [COUNTER] > [CLEAR] > [CLR-UNIT x EXC.]
PARTS COUNTER	PARTS xx	xx: Unit number of consumable parts (For details, refer to "Maintenance and Inspection" > "Consumable Parts") Initialize the counter amount of the consumable parts. (Clear [COUNTER] > [PARTS CNT.] > [PARTS x]) * After replacing the consumable part, be sure to execute this menu.

7.1.4 Sample Printout

a) PRINTINF

A sample printout that is produced by executing [SERVICE MODE] > [DISPLAY] > [PRINTINF] is shown below, along with instructions about how to interpret it.

(1) xxxxx PRINT INF
 Firm:00.49 Boot:00.31 MIT(DBF):9303 MIT(DB):1.02 S/N:DF029090

(2) SYSTEM
 TYPE:DF029090 24 0 TMP:26 SIZE_LF: 0.0 SIZE_CR: 514.3
 HEAD S/N:39410000
 HEAD LOT:166L09A0
 INK
 C :0 M :0 Y :0 MBK :0MBK2 :0 BK :0
 WARNING
 01:0000 02:0000 03:0000 04:0000 05:0000
 06:0000 07:0000 08:0000 09:0000 10:0000
 11:0000 12:0000 13:0000 14:0000 15:0000
 16:0000 17:0000 18:0000 19:0000 20:0000
 ERROR
 01:03060A00-2E01 02:0000 03:0000 04:0000 05:0000
 06:0000 07:0000 08:0000 09:0000 10:0000
 11:0000 12:0000 13:0000 14:0000 15:0000
 16:0000 17:0000 18:0000 19:0000 20:0000
 INK CHK: C:0 M:0 Y:0 MBK:0 MBK2:0 BK:0

(3) COUNTER
 PRINTER
 LIFE TTL:0
 LIFE ROLL:0 LIFE CUTSHEET:0 LIFE CASSETTE:0
 LIFE

MEDIA 7		MEDIA OTHER	
NAME	VALUE	NAME	OTHER
TTL	: 0.0 m2	TTL	: 0.0 m2 0.0 sq.f
ROLL	: 0.0 m2	ROLL	: 0.0 m2 0.0 sq.f
CUTSHEET	: 0.0 m2	CUTSHEET	: 0.0 m2 0.0 sq.f
CASSETTE	: 0.0 m2	CASSETTE	: 0.0 m2 0.0 sq.f

	(a)	(b)	(c)	(d)	(e)	(f)
PARTS COUNTER						
COUNTER A :	OK	36	0.0	36.1	0%	0.0
PARTS A1 :						
COUNTER B :	OK	36	0.0	64.0	0%	0.0
PARTS B1 :						
COUNTER D :	OK	36				
PARTS D1 :			1362	13028571	0%	1362
PARTS D2 :			377	6700000	0%	377
PARTS D3 :			2238	16500000	0%	2238
PARTS D4 :		33		60000	0%	33
COUNTER F :	OK	36				
PARTS F1 :			377	4000000	0%	377
COUNTER H :	OK	36				
PARTS H1 :		15		50000	0%	15
COUNTER L :	OK	36				
PARTS L1 :			4	12500	0%	4
COUNTER P :	OK	36				
PARTS P1 :			0	750	0%	0
COUNTER Q :	OK	36				
PARTS Q1 :			0	750	0%	0
COUNTER R :	OK	36				
PARTS R1 :			0	27500	0%	0
COUNTER V :	OK	36				
PARTS V1 :			0.0	15.2	0%	0.0

(4) PV AUTO JUDGE

(a) (b)

F-7-1

- (1) Version numbers of the firmware installed in the printer, boot ROM, and MIT DB format
- (2) Printer information
For more item details, see "Detail of Service Mode" > "a) Display".
- (3) Counter information
For more item details, see "Detail of Service Mode" > "e) Counter".
 - (a) Consumables status
 - (b) Number of days elapsed since the counter was last reset
 - (c) Counter value
 - (d) Value with which consumables reach their replacement timing
 - (e) Ratio of the current count to the replacement timing
 - (f) Cumulative counter value
- (4) Ink saver mode setting
 - (a) Ink saver mode status
 - (b) Number of times ink save mode has been executed (unit: times).

b) NOZZLE 1

A sample printout that is produced by executing [SERVICE MODE]> [ADJUST]> [PRINT PATTERN]> [NOZZLE 1] is shown below.

Nozzle Check Pattern SERVICE

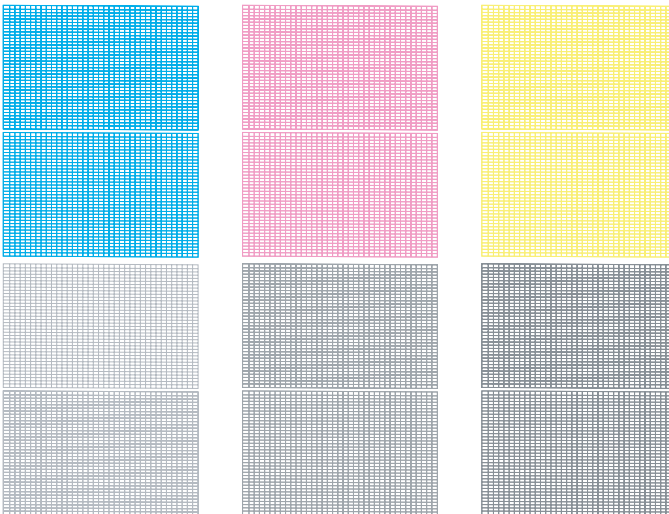

F-7-2

c) NOZZLE 2/NOZZLE 3

A sample printout that is produced by executing [SERVICE MODE]> [ADJUST]> [PRINT PATTERN]> [NOZZLE 2] or [NOZZLE 3] is shown below.

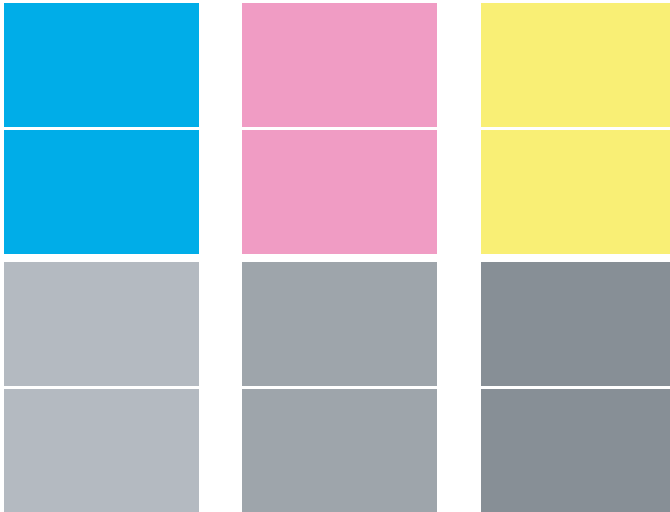

F-7-3

d) OPTICAL AXIS

A sample printout that is produced by executing [SERVICE MODE]> [ADJUST]> [PRINT PATTERN]> [OPTICAL AXIS] is shown below.

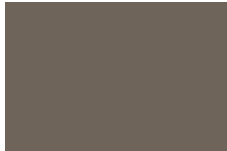

F-7-4

e) **DETAIL**

A sample printout that is produced by executing [SERVICE MODE]> [ADJUST]> [HEAD ADJ.] > [AUTO HEAD ADJ]> [DETAIL] is shown below.

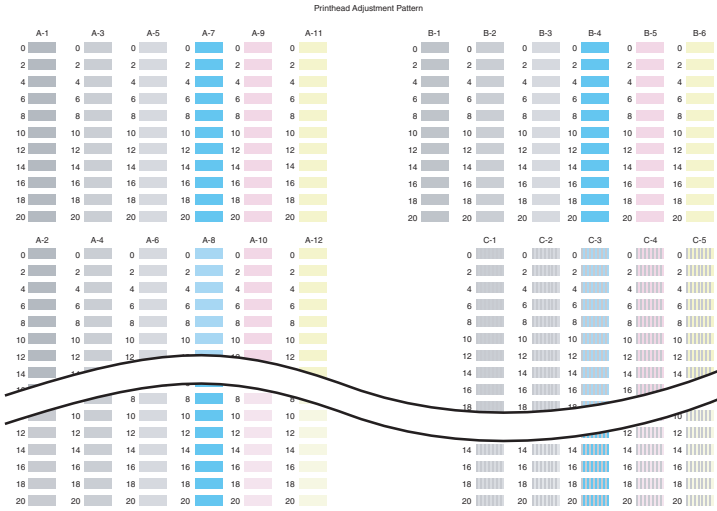

Canon imagePROGRAF IPF600 Printhead Adjustment Pattern

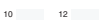
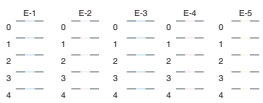
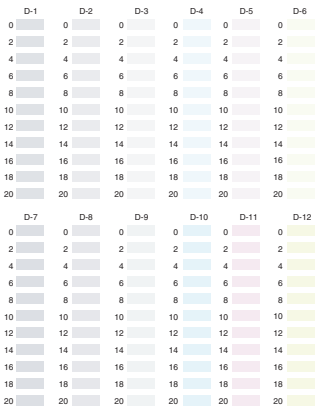

f) BASIC

A sample printout that is produced by executing [SERVICE MODE]> [ADJUST]> [HEAD ADJ.] > [AUTO HEAD ADJ]> [BASIC] is shown below.

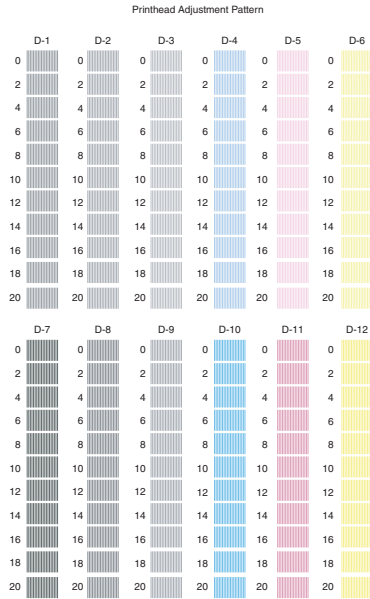

F-7-6

7.2 Special Mode

7.2.1 Special Modes for Servicing

This printer supports the following special modes in addition to the service mode:

- **PCB replacement mode**
 - **Download mode**
 - **Counter display mode**

1. PCB replacement mode

This mode is used when replacing the main PCB or MC relay PCB.

By executing this mode,

- Backup data of the settings and counter values stored in the MC relay PCB are moved to the new main PCB.
- The data such as the settings and counter values are copied to the MC relay PCB.

a) Entering the PCB replacement mode

Follow the same procedure as that for entering the service mode.

(With the "Paper Source" button and "Information" button pressed down, turn on the "Power" button.)

When the printer starts up, compare the serial number memorized in the main PCB's EEPROM with that memorized in the MC relay PCB's EEPROM. If they do not match, or no serial number is memorized in either EEPROM, enter the PCB replacement mode.

While you are in the PCB replacement mode, the MESSAGE LED, roll media LED, and ONLINE LED are lit.

b) Procedure

Select "CPU BOARD" or "MC BOARD" using the [◀] and [▶] buttons, and then press the [OK] button to determine it.

- CPU BOARD

Select this after replacing the main PCB.

The data in the MC relay PCB is copied to the main PCB.

- MC BOARD

Select this before replacing the main PCB.

The data in the main PCB is copied to the MC relay PCB.

Use this when the MC relay PCB is a new one.

c) Exiting the PCB replacement mode

Turning off the Power button of the printer allows you to exit the PCB replacement mode.

For details on how to replace the PCB, see Parts Replacement Procedure > Disassembly/Reassembly > Points to Note on Disassembly and Reassembly > Boards.

2. Download mode

Use this mode only when updating the firmware without performing initialization.

a) Entering the download mode

1) Turning off the Power button of the printer.

2) With the "Stop" and "Information" buttons pressed down, turn on the Power button of the printer.

* Keep pressing the above buttons until "Initializing" appears on the display.

b) Procedure

When "Download Mode/Send Firmware" is shown on the display, transfer the firmware. When downloading of the firmware is completed, the printer is turned off automatically.

3. Counter display mode

Use this mode to view only printer counter information.

a) Invoking counter display mode

1) Press the [MENU] button to keep [Information] > [System Info] selected.

2) Press the [▲] button while holding down the [MENU] button + [OK] button to invoke counter display mode.

b) How to view counter display mode

- S/N: Unit serial number

- CNT: Number of copies printed in A4 terms (unit: copies)

Chapter 8 ERROR CODE

Contents

8.1 Outline	8-1
8.1.1 Outline	8-1
8.2 Warning Table	8-2
8.2.1 Warnings	8-2
8.3 Error Table	8-3
8.3.1 Error Code List	8-3
8.4 Service Call Table	8-6
8.4.1 Service call errors	8-6

8.1 Outline

8.1.1 Outline

The printer indicates errors using the display and LEDs.

If an error occurs during printing, the printer status is also displayed on the status monitor of the printer driver. The following three types of errors are displayed on the display:

- Warning

Status where the print operation can be continued without remedying the cause of the problem. This can, however, adversely affect the printing results.

- Error

Status where the print operation is stopped, and the regular operation cannot be recovered until the cause of the problem is remedied.

- Service call error

When a service call error occurs, the error is not cleared and the error indication remains on the operation panel even if the printer is powered off and on again. (Occurrence of the service call error is indicated again at power-on.)

This measure is taken to prevent user's recovery of the service call error and damages to the printer.

Service call errors can be cleared, however, by starting up the printer in the service mode.

For how to take actions against warnings and errors, refer to "Troubleshooting".

Overview of warnings and error codes

T-8-1

Code*	Diagnosis
W100x	Ink warning
W110x	Waste ink warning
W12xx	GARO warning
03xxxxxx-20xx	Media feeding error
03xxxxxx-2Exx	Data mismatch error
03xxxxxx-25xx	Ink error
03xxxxxx-280x	Printhead error
03xxxxxx-281x	Maintenance cartridge error
03xxxxxx-282x	Adjustment error
03xxxxxx-2Fxx	Other errors
Exxx-40xx	Service call error

* "x" stands for a numeric or letter.

8.2 Warning Table

8.2.1 Warnings

The codes correspond to the numbers shown on the DISPLAY in the service mode.

T-8-2

Code	Display message	Status
1000	Ink Lvl: Chk	BK ink tank is almost empty
1001	Ink Lvl: Chk	Y ink tank is almost empty
1002	Ink Lvl: Chk	M ink tank is almost empty
1003	Ink Lvl: Chk	C ink tank is almost empty
1006	Ink Lvl: Chk	MBK ink tank is almost empty
1007	Ink Lvl: Chk	MBK2 ink tank is almost empty
100F	Feed Limit...	Force feed limit
1010	Check printed document.	Ink non discharging
1100	Check maint cartridge capacity.	Maintenance cartridge is almost full
1221	GARO W1221	Unsupported command in GARO image mode
1222	GARO W1222	Invalid number of parameters in GARO image mode (no parameter)
1223	GARO W1223	Required item was omitted in GARO image mode
1225	GARO W1225	Other warning in GARO image mode
1231	GARO W1231	Unsupported command in GARO setting mode
1232	GARO W1232	Invalid number of parameters in GARO setting mode
1233	GARO W1233	Required item was omitted in GARO setting mode
1234	GARO W1234	Data out of range in GARO image mode
1235	GARO W1235	Other warning in GARO setting mode
	Prepare for parts replacement. Call for service.	Parts counter warning level 1
	Parts replacement time has passed. Call for service.	Parts counter warning level 2

8.3 Error Table

8.3.1 Error Code List

The codes correspond to the numbers shown on the DISPLAY in the service mode.

T-8-3

Code*	Description
03010000-200C	Media leading edge not detected
03010000-200D	The trailing edge of cut sheet cannot be detected
03010000-200E	Too small media
03010000-200F	Too large media
03010000-2016	Paper came off at paper feed.
03010000-2017	Media right edge not detected
03010000-2018	Media left edge not detected
03010000-2820	Head registration in proper adjustment
03010000-2821	LF adjustment error
03010000-2822	Eccentricity improper adjustment
03010000-2823	Printhead check error
03010000-2E1F	Media is too small to print adjustment pattern
03010000-2E27	Media became misaligned during printing
03010000-2F33	Transparent media was loaded and cannot adjust
03016000-2010	Skewed media
03016000-2010	Skewed media
03030000-2E21	IEEE1394 error
03031000-2E0F	Upper cover error
03031000-2E11	Printhead fixer cover error
03031000-2E12	Release lever error
03060000-2E14	Width indicated by received data does not match width of paper
03060A00-2E00	Roll media was loaded even though the received data indicated roll media.
03060A00-2E1B	End of roll media
03061000-2E15	Media type indicated by data does not match
03130031-260E	Gap detection error
03130031-260F	Standard side seat error(not generated in the user mode.)
03130031-2618	VH voltage error
03130031-2F13	A/D converter outside trigger output stop
03130031-2F14	ASIC register writing error
03130031-2F16	Mist fan error
03130031-2F17	Platen fan error
03130031-2F1F	Purge motor HP error
03130031-2F20	Purge motor error
03130031-2F22	Pump movement timeout
03130031-2F23	Pump cannot operate

Code*	Description
03130031-2F25	Unable to detect CR motor HP
03130031-2F26	Carriage cannot operate
03130031-2F27	Carriage movement timeout
03130031-2F2A	Feed roller HP sensor error
03130031-2F2D	Pump error
03130031-2F2E	Roll movement timeout
03130031-2F32	Multi sensor faulty
03130031-2F3A	Valve motor error
03130031-4027	Lift movement time-out
03800200-2802	Incorrect printhead was installed
03800200-2811	Difference of version of print head
03800300-2801	Unable to correct printhead DI
03800400-2803	Printhead EEPROM error
03800500-280C	Many nozzle on printhead did not inject ink
03800500-2F2F	No ink ejection detection error
03800500-2F30	No ink ejection detection position adjustment error
03810101-2501	No ink (Y)
03810102-2502	No ink (M)
03810103-2503	No ink (C)
03810104-2500	No ink (BK)
03810106-2506	No ink (MBK)
03810106-2507	No ink (MBK2)
03810201-2581	Remaining ink low (Y)
03810201-2591	Remaining ink low (Y)
03810202-2582	Remaining ink low (M)
03810202-2592	Remaining ink low (M)
03810203-2583	Remaining ink low (C)
03810203-2593	Remaining ink low (C)
03810204-2580	Remaining ink low (BK)
03810204-2590	Remaining ink low (BK)
03810206-2586	Remaining ink low (MBK)
03810206-2587	Remaining ink low (MBK2)
03810206-2596	Remaining ink low (MBK)
03810206-2597	Remaining ink low (MBK2)
03830101-2521	Ink tank not installed (Y)
03830102-2522	Ink tank not installed (M)
03830103-2523	Ink tank not installed (C)
03830104-2520	Ink tank not installed (BK)
03830106-2526	Ink tank not Installed (MBK)
03830106-2527	Ink tank not installed (MBK2)
03830201-2541	Ink tank ID error (Y)

Code*	Description
03830202-2542	Ink tank ID error (M)
03830203-2543	Ink tank ID error (C)
03830204-2540	Ink tank ID error (BK)
03830206-2546	Ink tank ID error (MBK)
03830206-2547	Ink tank ID error (MBK2)
03830301-2561	Ink tank EEPROM error (Y)
03830302-2562	Ink tank EEPROM error (M)
03830303-2563	Ink tank EEPROM error (C)
03830303-2572	Remaining ink low (M)
03830304-2560	Ink tank EEPROM error (BK)
03830304-2570	Remaining ink low (BK)
03830306-2566	Ink tank EEPROM error (MBK)
03830306-2567	Ink tank EEPROM error (MBK2)
03830306-2576	Remaining ink low (MBK)
03830306-2577	Remaining ink low (MBK2)
03830312-2571	Remaining ink low (Y)
03830313-2573	Remaining ink low (C)
03841001-2819	Maintenance cartridge tank full
03841001-281B	Empty capacity of the maintenance cartridge when cleaning it various is insufficient.
03841101-2818	Maintenance cartridge not installed
03841201-2816	Maintenance cartridge EEPROM error
03841201-2817	Maintenance cartridge ID error
03860002-2E02	The cut sheet is not set though the data of the cut sheet specification was received.
03860002-2E0A	Manually fed cut sheet was already loaded even though received data indicated roll media
03860002-2E0C	When the roll paper was loaded, the data of the cut sheet specification was received.
03861001-2405	The form set position is unsuitable to the print of edge none.
03861001-2406	Data is unsuitable to the print of edge none.
03862000-2E09	Roll paper running out
03870001-2015	Cutting failure
03900001-4042	MIT data transfer failure
03900001-4049	Forwarding ROM data machine kind difference
E194-4034	Sensor calibration error(not generated in the use mode.)

8.4 Service Call Table

8.4.1 Service call errors

*Codes correspond to the numbers shown on the DISPLAY in the service mode.

T-8-4

Code*	Description	Display message
E141-4046	Recovery system rotation count reached 50,000.	ERROR Exxx-xxxx Call For Service
E144-4047	Feed system counting error	
E146-4001	Borderless/idle ejection/mist recovery count full	
E161-403E	Abnormally high printhead temperature	
E194-404A	No ink ejection counting error	
E196-4040	Checksum error	
E196-4041	Flash memory clearing error	
E196-4042	Flash memory write error	
E196-4043	Main controller error	
E196-4044	EEPROM size error	
E196-4045	EEPROM write error	
E198-401C	RTC error	
E198-401D	RTC low battery error	
E198-401E	RTC clock stopped	

APPENDIX

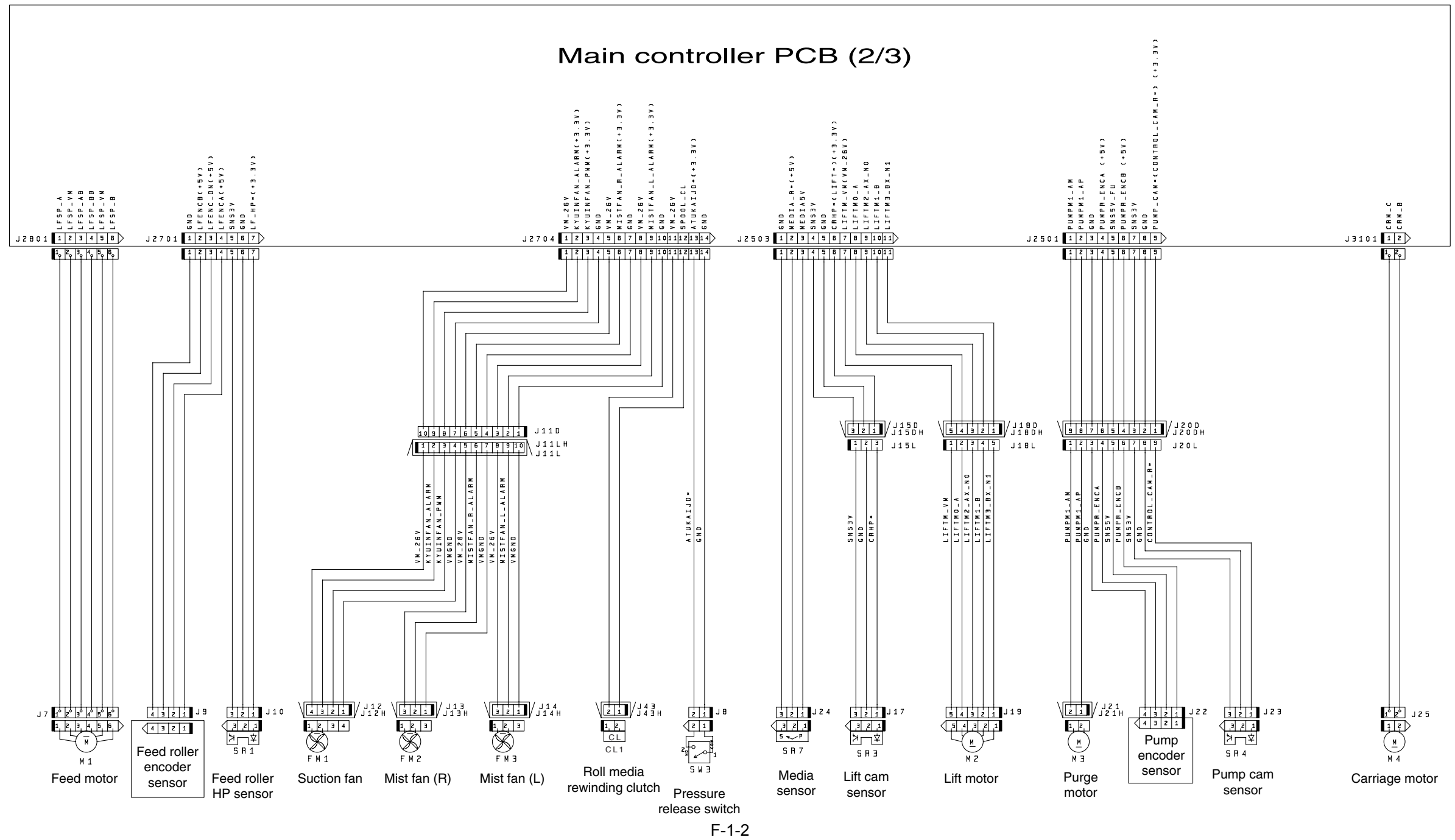

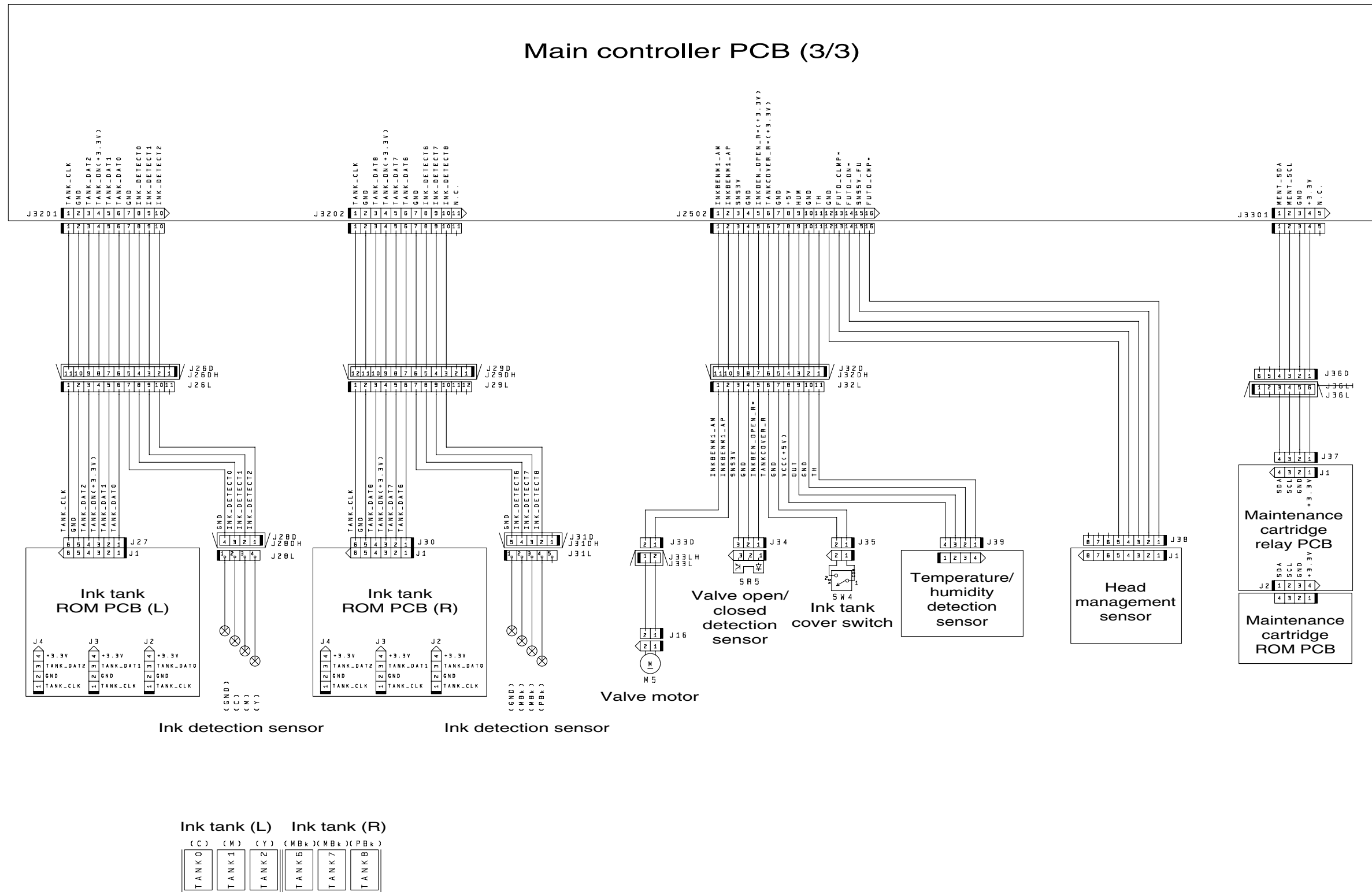

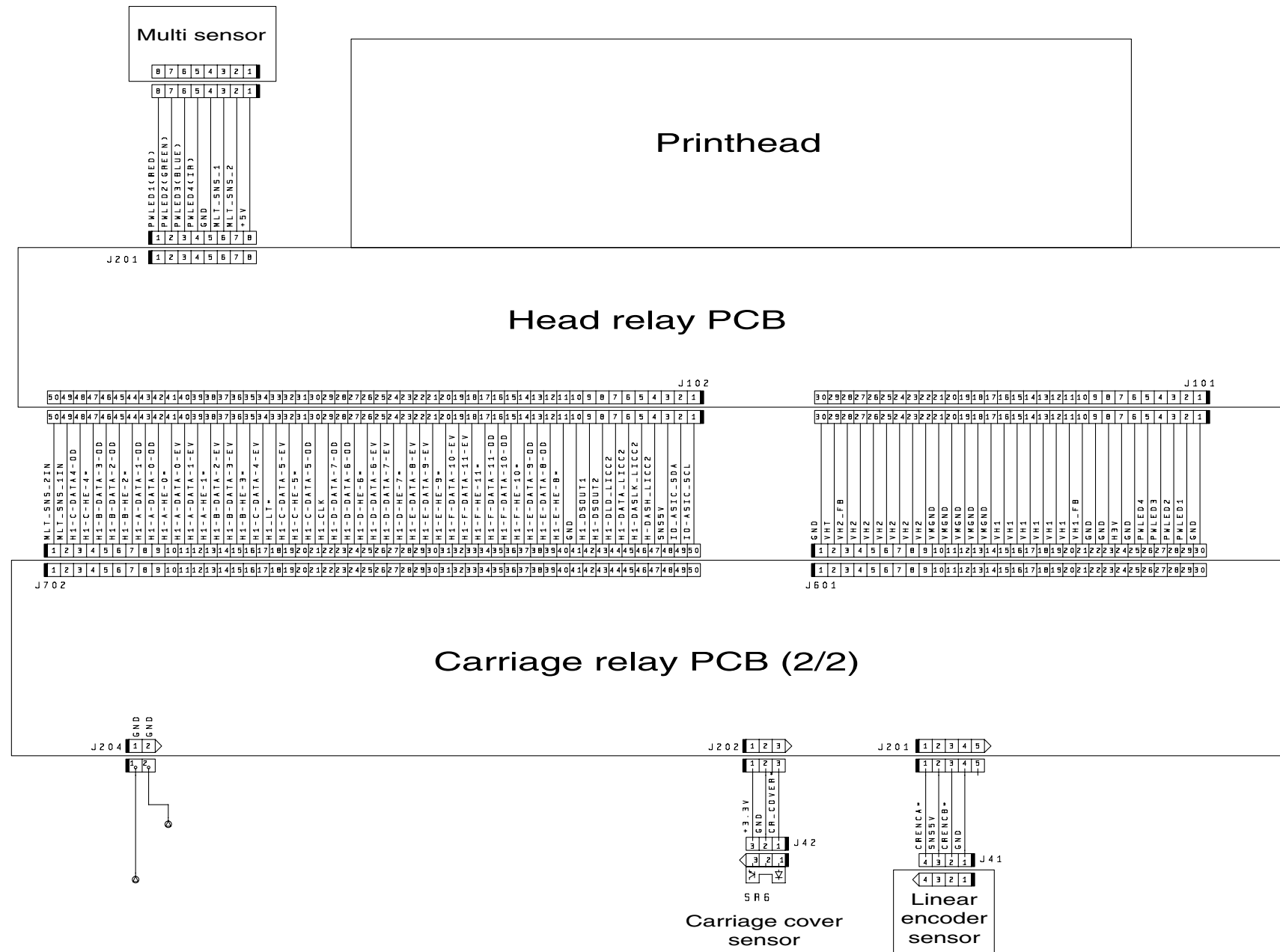

F-1-4

Canon

Free Manuals Download Website

<http://myh66.com>

<http://usermanuals.us>

<http://www.somanuals.com>

<http://www.4manuals.cc>

<http://www.manual-lib.com>

<http://www.404manual.com>

<http://www.luxmanual.com>

<http://aubethermostatmanual.com>

Golf course search by state

<http://golfingnear.com>

Email search by domain

<http://emailbydomain.com>

Auto manuals search

<http://auto.somanuals.com>

TV manuals search

<http://tv.somanuals.com>