

BJC-620

USER'S MANUAL

Canon

BJC-620 Table of Contents

1. Introduction	1 – 1
Supplies and Accessories	1 – 2
Ink Tanks	1 – 2
Canon Specialty Papers	1 – 2
Getting Help From Canon	1 – 3
Servicing the Printer	1 – 4
2. Using the Microsoft Windows Printing System	2 – 1
Understanding the Microsoft Windows Printing System	2 – 2
Checking the Computer Requirements	2 – 2
Printing With the Microsoft Printing System	2 – 3
Using On-Line Help	2 – 4
Using the Microsoft Windows Printing System Program Group	2 – 5
The Microsoft Windows Printing System Dialog Boxes	2 – 6
Opening the Microsoft Windows Printing System Dialog Boxes	2 – 6
Overview of the Microsoft Windows Printing System	2 – 8
Microsoft Windows 95	2 – 8
Microsoft Windows 3.1 or Microsoft Windows for Workgroups 3.1	2 – 11
Checking the Status of a Print Job	2 – 13
Using the Status Window	2 – 14
Opening the Status Window	2 – 14
Using the Toolbar	2 – 15
Using the Status Window as an Icon	2 – 15
Messages Displayed in the Status Window	2 – 17
Customizing the Status Window	2 – 18
Customizing Display Options	2 – 18
Maintaining the Printer From the Status Window	2 – 19
The Printer Options Dialog Box	2 – 20
3. Paper Handling	3 – 1
Selecting Paper Types	3 – 2
Paper Guidelines	3 – 4
Before Loading Paper	3 – 5
Setting the Paper Thickness Lever	3 – 5
Setting the Paper Selection Lever and the Paper Support	3 – 6
Printer Settings for Various Print Media	3 – 8
Automatically Feeding Paper	3 – 9
Auto Feed Guidelines	3 – 13
Manually Feeding Paper	3 – 15
Printing on Envelopes	3 – 18
Preparing Your Software	3 – 18
Loading Envelopes	3 – 19
Using Canon Specialty Paper	3 – 22

	Canon's High Resolution Paper HR-101	3 – 22
	Fabric Sheets FS-101	3 – 24
4.	Maintaining the Printer	4 – 1
	Printer Guidelines	4 – 1
	Cleaning the Printer	4 – 3
	Cleaning the Print Head Unit	4 – 4
	Using the Microsoft Windows Printing System	4 – 5
	Using the Operator Panel	4 – 5
	Ink Tank Guidelines	4 – 7
	Replacing an Ink Tank	4 – 8
	Replacing the Print Head Unit	4 – 12
	Print Head Unit Guidelines	4 – 12
	Removing the Used Print Head Unit	4 – 13
	Installing a New Print Head Unit	4 – 14
	Transporting the Printer	4 – 18
5.	Troubleshooting	5 – 1
	Using Canon's Support Services	5 – 1
	Identifying Your Printer Problem	5 – 2
	General Problems	5 – 3
	Initialization Errors	5 – 3
	Clearing Paper Jams	5 – 5
	Ink Problems	5 – 6
	Ink Tanks Continually Run Out of Ink	5 – 6
	Ink Tank Incorrectly Installed	5 – 7
	Troubleshooting the Microsoft Windows Printing System	5 – 7
	Technical Notes	5 – 11
	Bios Setups for Various Systems	5 – 11
Appendix	Specifications	A – 1
A		
Appendix	Using the BJC-620 in a Network Environment	B – 1
B		
Glossary		G – 1
Index		I – 1
FCC Regulations		FCC – 1
Warranty		W – 1



Congratulations on your purchase of the Canon BJC-620 Color Bubble Jet Printer. We appreciate your choosing this printer to meet your printing needs.



Your printer features the Microsoft Windows Printing System, which makes printing from Microsoft Windows faster and easier than ever before. With the Microsoft Windows Printing System, your printer is able to print faster than traditional approaches. As soon as the Microsoft Windows Printing System accepts a document for printing, you can return to your application. You receive instant notification of printer information and you can see the printer's status on your computer screen.

The BJC-620 offers exceptionally high print quality and fast print speed using both color and black inks. We are certain you will be satisfied with its advanced Bubble Jet technology.

This chapter:

- Lists the supplies and accessories you can purchase for the printer
- Describes Canon's customer support services

Supplies and Accessories

Your BJC-620 printer supports excellent and unique print media options that will allow you to produce dazzling, professional, and fun presentations. All of these print media are specially designed and manufactured to work with your Canon color printer so you can produce the finest output possible.



Canon has an extensive dealer network equipped to offer you supplies as you need them. To find a dealer near you, call the Canon Referral Service at **1-800-848-4123**.

If supplies are not available from your local dealer, you can order directly from Canon by calling **1-800-671-1090**.

Ink Tanks

Your BJC-620 comes with the following ink tanks:

- Canon Ink Tank BJI-201 Bk HC (black, high capacity)
- Canon Ink Tank BJI-201 C (cyan)
- Canon Ink Tank BJI-201 M (magenta)
- Canon Ink Tank BJI-201 Y (yellow)

Canon Specialty Paper

Canon manufactures various specialty papers, including:

- Bubble Jet Paper LC-301 (water resistant)
- Coated Paper LC-101
- High Resolution Paper HR-101
- Transparency CF-102
- Back Print Film BF-102
- High Gloss Film HG-101
- Fabric Sheet FS-101
- T-Shirt Transfers TR-101
- Greeting Cards GC-101
- Brochure Paper BP-101

See Chapter 3, *Paper Handling*, for details on Canon's specialty papers.

Getting Help From Canon

Canon provides experienced support personnel to help you in every way



On-line Support Services

You can easily contact Canon on the World Wide Web. Our address is:

<http://www.ccsi.canon.com>

Canon provides a bulletin board service (BBS), which is useful for obtaining newly developed third-party drivers. Call **1-757-420-2000**. The protocol for the BBS is up to 28,800 bps, eight data bits, one stop bit, and no parity.

If you use CompuServe®, You can access the Canon Peripherals Forum. This allows you to talk with other users, send a message to Canon, or download printer drivers. Just type GO CANON at any CompuServe prompt.

- If you have a modem, you can connect to Canon through the Web, its BBS, or CompuServe. Through these on-line services, you can retrieve general information about specific products.
- If you are looking for information about any Canon printer driver for a unique situation, you can contact one of the Canon on-line services.
- You can retrieve information from the on-line services at any hour of the day or night.

Fax Retrieval System



Canon provides a 24-hour, toll-free Fax Retrieval System. You can use this service to get helpful documents faxed directly to your fax machine. These documents contain useful information to assist you in the operation of your Canon printer. To access this service, call **1-800-526-4345**.

- One of the first things you may want to do after setting up your printer is call the Canon Fax Retrieval System and request an index of the documents available to you through this service. Documents will be faxed directly to your fax machine.
- The Fax Retrieval System offers up-to-date information about specific products. By reviewing the index, you can determine what information would be beneficial to your installation.



Customer Care Center

Canon provides customer support and service for all Canon printer products. If you have any questions regarding your new printer, call the Canon Computer Systems Customer Care Center at **1-800-423-2366**. Support is available from 6 A.M. to 12 MIDNIGHT Eastern Standard Time. (EST) Seven days a week except holidays.

- If you seem to have an operational problem, try to solve it by using the Super Solver. If you cannot quickly resume normal operation, contact Canon's experienced support personnel at the Customer Care Center.

Servicing the Printer

The Canon BJC-620 Color Bubble Jet Printer is designed with the latest technology to provide trouble-free operation. The warranty information at the back of the manual describes Canon's limited one-year warranty for its Bubble Jet printers. Be sure to read the warranty information to find out about the different service options available to you.



Save your sales receipt for proof of purchase. In the event that your printer needs service, you will need your proof of purchase to obtain warranty service.

If you feel your BJC-620 Color Bubble Jet Printer needs servicing, contact Canon on the World Wide Web to locate the Canon Authorized Service Facility (ASF) nearest you or to find out about the exclusive Canon Instant Exchange warranty program. If you do not have access to the Web, call the Customer Care Center.

Using the Microsoft Windows Printing System

2



This chapter introduces you to the Microsoft Windows Printing System for the BJC-620. It includes:

- Understanding the Microsoft Windows Printing System
- Printing with the Microsoft Windows Printing System
- Using the Microsoft Windows Printing System program group
- The Microsoft Windows Printing System dialog boxes
- Overview of the Microsoft Windows Printing System
- Checking the status of a print job
- Using the Status Window
- Customizing display options
- Maintaining the printer from the Status Window

Understanding the Microsoft Windows Printing System

The Microsoft Windows Printing System manages the communications between your computer and printer. It divides the work between the two, helping the printer and computer work together to optimize performance.

The Microsoft Windows Printing System processes documents from Microsoft Windows applications faster than traditional methods, and lets you quickly see the status of your print job. If you install the included sound files, your computer will actually tell you verbally what your printer is doing.

Checking the Computer Requirements

Your *Quick Start Guide* describes how to install the Microsoft Windows Printing System. To use the system, make sure your computer system has the following minimum configuration:

- 386SX 16MHz personal computer
- 10 MB of physical and virtual memory combined, of which at least 4 MB must be physical RAM
- VGA or super VGA color graphics monitor
- 6 MB of available disk space for full installation of Microsoft Windows Printing System
- Microsoft Windows 95, Microsoft Windows 3.1, or Microsoft Windows for Workgroups 3.1
- Parallel printer port with bi-directional communication capability

The printer may not print some pages at high resolution with the system above. In this case, the following are suggested.

- 486SX 25MHz personal computer
- 16 MB of physical and virtual memory combined, of which at least 8 MB must be physical RAM



You need a sound card to play sounds with the Microsoft Windows Printing System messages.

Printing With the Microsoft Windows Printing System

One-way communication from computer to printer has been the standard for years. The Microsoft Windows Printing System offers dynamic two-way communication. With the Microsoft Windows Printing System, your computer knows what your printer is doing.

To take advantage of the dynamic two-way communication, one end of a bi-directional parallel cable connects to the printer and the other end connects directly to your computer



You must use a bi-directional cable for proper operation. Also, your computer's interface must have bi-directional capability. If your computer tells you that it cannot find the BJC-620 printer, but the printer is plugged in, turned on, and connected to the computer, see the Technical Notes starting on page 5-11.

Every time you print, the Microsoft Windows Printing System displays the Status Window. This window shows you the paper moving through the printer, how long it will take to print the document, and how much of the document has printed. From the Status Window you can pause, resume, force, or delete the print job, print the self test, or clean the print heads.



If a printing problem occurs, the Status Window automatically opens and tells you what the problem is.

Before using the Microsoft Windows Printing System, make sure you have selected it as your current Microsoft Windows printer driver. The Setup program makes the Microsoft Windows Printing System the default printer driver. If you have not changed drivers since running the Setup program, you are ready to print.



To verify that the Microsoft Windows Printing System is your printer driver, use the Printers option in the Microsoft Windows Control Panel. The highlighted driver is the current printer driver. Change drivers by clicking on the one you want.

Using On-line Help

The Microsoft Windows Printing System includes extensive on-line help that describes the printer and its basic operation. You can get on-line help as follows.

Microsoft Windows 95

- In the Properties dialog box:
 - Use the right mouse button to click an item on the screen.
 - Click the ? button (on the upper right corner of the screen) and then click an item.
 - Press **F1**.

Select Programs from the Start menu, then click on Canon BJC-620 Help in the Microsoft Windows Printing System folder.

Microsoft Windows 3.1

- Choose the Help button or press **F1** while in the Setup dialog box.
- Double-click on the Canon BJC-620 Help icon in the Microsoft Windows Printing System group.

Using the Microsoft Windows Printing System Program Group

When you install the Microsoft Windows Printing System, you create the Microsoft Windows Printing System program group, from which you can select the following:



Canon BJC-620 Installation

Starts the installation program for the Microsoft Windows Printing System. You can use this program to add features to the Microsoft Windows Printing System that you did not originally install.



Canon BJC-620 ReadMe

Provides you with the latest information about using the Microsoft Windows Printing System with your printer.



Printers Folder

Opens the BJC-620 Properties dialog boxes, which you can use to set the printing options for Microsoft Windows 95.



Canon BJC-620 Status Window

Displays the Status Window so you can check the status of a print job.



Canon BJC-620 Help

Selects the Canon BJC-620 Help file for the Microsoft Windows Printing System.

Printer Setup



Selects the Printer Setup dialog box, which you can use to set the printing options in Microsoft Windows 3.1 or Microsoft Windows for Workgroups 3.1.

Print Manager



Selects the Microsoft Windows Print Manager for Microsoft Windows 3.1 or Microsoft Windows for Workgroups 3.1.



Canon BJC-620 Uninstallation

Starts the program to uninstall the Microsoft Windows Printing System.

From Microsoft Windows 95

From the Microsoft Windows 95 Printer folder:

1. Click the Start button, point to Settings, and then click Printers.
2. Click the icon for the printer you are using.
3. On the File menu, click Properties to open the Properties dialog box.

From Microsoft Windows 3.1

Use the Control Panel or Print Manager:

1. Open the Control Panel, then double-click on the Printers icon to open the Printers dialog box. Or open the Print Manager, then choose the Printer Setup... command from the Options menu to open the Printers dialog box.

You can open the Control Panel or the Print Manager by doubleclicking on the Control Panel or Print Manager icons in the Main group of the Program Manager.

2. In the Printers dialog boxes, make sure BJC-620 on LPT1 is highlighted and then choose the Setup... button to open the Setup dialog box.



You can open the Printer Setup dialog box, Print Manager, or Printers folder from the Microsoft Windows Printing System group.

The way you get to the dialog boxes determines how long the printing options remain in effect:

- If you start from an application's Print... command, your choices apply only to that print job. The next time you print, you have to choose the print settings again.
- If you start from an application's Print Setup... command, the application stores your choices with the document.
- If you start from the Control Panel or Print Manager, the settings apply to all Microsoft Windows applications and remain in effect until you change those settings.



Note

Many applications do not follow the above Microsoft Windows guidelines. Until you are familiar with how your Microsoft Windows application uses the Microsoft Windows Printing System settings, it's a good idea to verify the settings each time you print.

Overview of the Microsoft Windows Printing System

The Microsoft Windows Printing System dialog boxes, where you select printing options, differ depending on whether you are using Microsoft Windows 95 or Microsoft Windows 3.1 or Microsoft Windows for Workgroups 3.1.

Microsoft Windows 95

You select printing options with the following tabs.

- **General**
Prints a test page and a separator page.

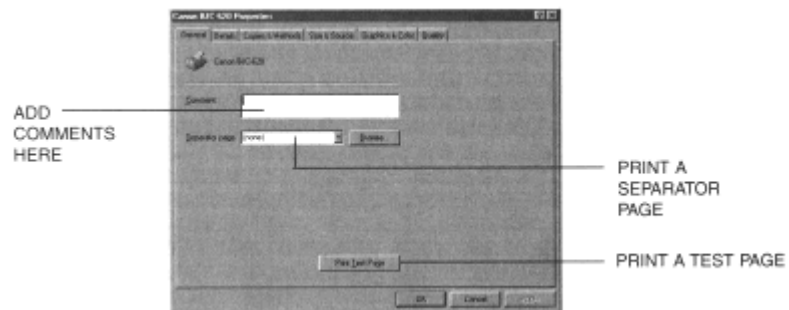

- **Details**
Specifies printer port settings and timeout settings.

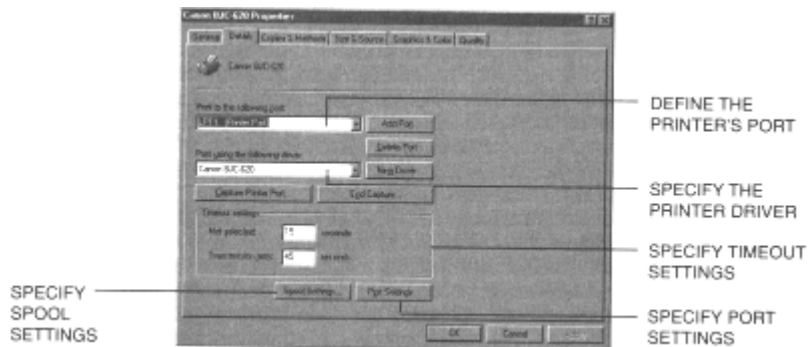

- **Copies & Methods**
Specifies multiple copies, collated or not, and the print orientation.

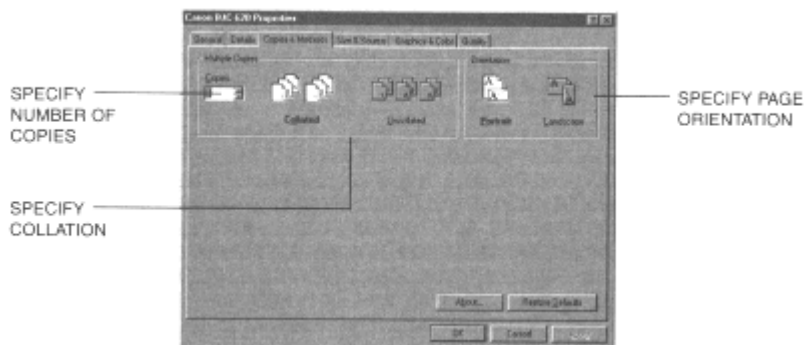

- **Size & Source**
Chooses the paper source and paper size.

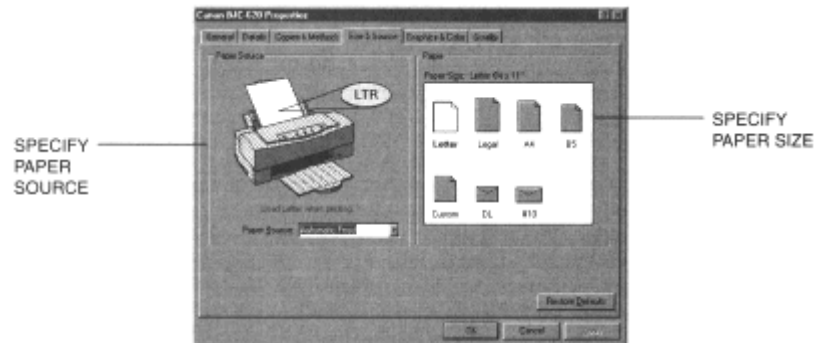

- **Graphics & Color**
Chooses the paper source and paper size.

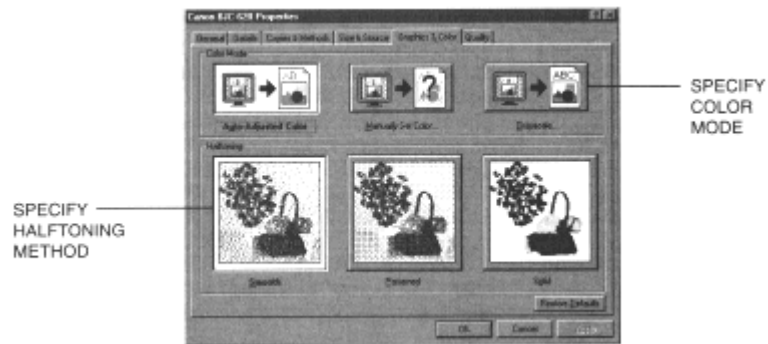



- **Quality**

Chooses the resolution setting, print media, and print quality. The resolution settings are Draft (180 x 180 dpi), Normal (360 x 360 dpi), and Best (720 x 720 dpi).

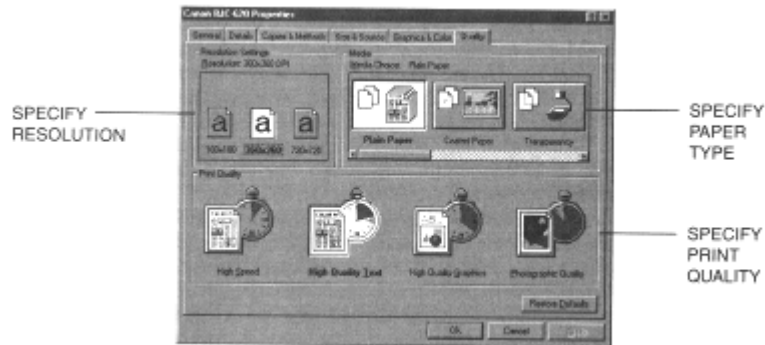

For detailed information on the Microsoft Windows Printing System printer options settings, refer to the on-line help.

Microsoft Windows 3.1 or Microsoft Windows for Workgroups 3.1

You select printing options in the following dialog boxes.

- **Printer Setup dialog box**

This is the first dialog box you open from your application program. You can select multiple copies, collated or not collated, paper orientation, paper source, and paper size.

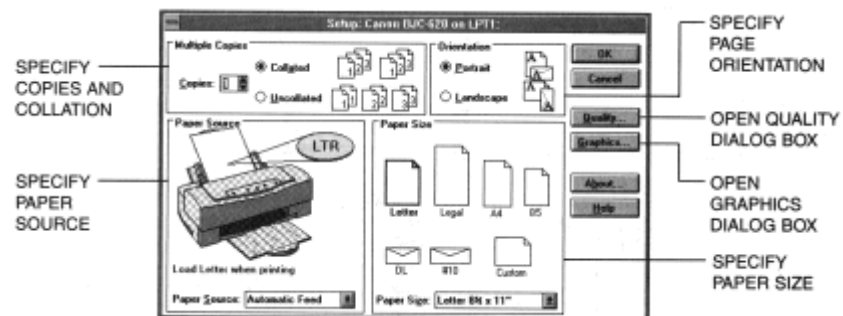



You open the Quality and Graphics dialog boxes from the Printer Setup dialog box.

- **Quality dialog box**

Selects media type, printer resolution, and print quality. The resolution settings are Draft (180 x 180 dpi), Normal (360 x 360 dpi), and Best (720 x 720 dpi).

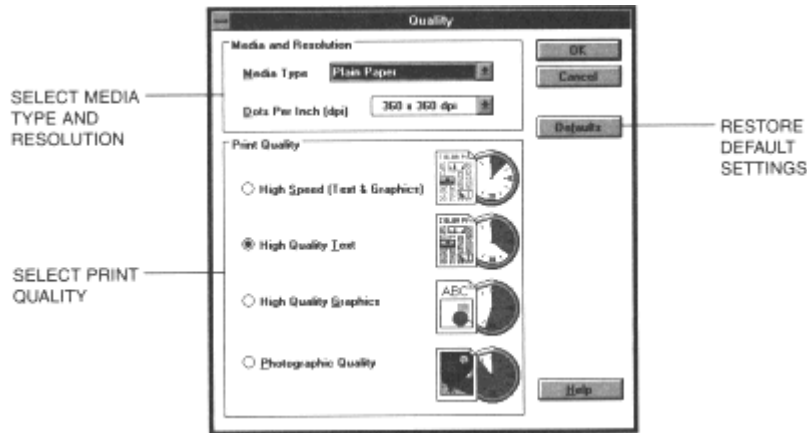

- **Graphics dialog box**

Selects the halftoning method, adjusts brightness, contrast, and saturation, enables gray scale printing, and disables the Microsoft Windows Printing System color matching

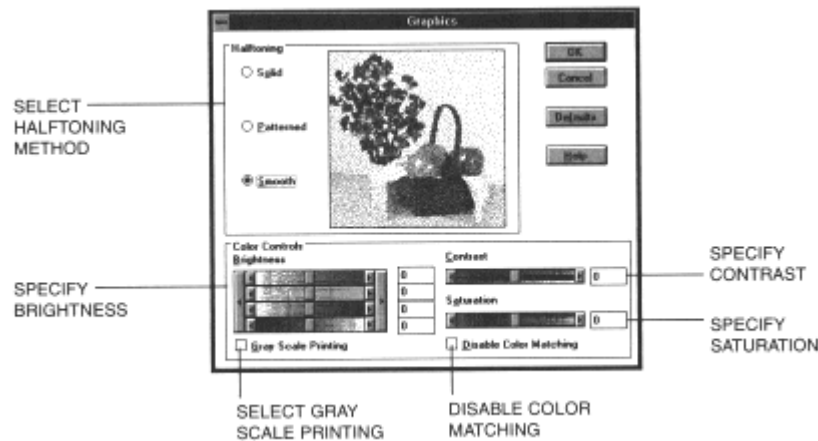



For detailed information on the Microsoft Windows Printing System printer options settings, refer to the on-line Help by pressing the Help button or by pressing **F1**.



Note

- When your computer is connected to a network, you can also open the Sharing tab.
 - For optimum print quality when you select 720 x 720 dpi, choose Smooth haiftoning from the Graphics dialog box or Graphics & Color tab. We also recommend using Canon High Resolution Paper (HG-101).
-

Checking the Status of a Print Job

With the Microsoft Windows Printing System, you can keep track of and control your print jobs using the Status Window. It tells you exactly what is happening with the current print job. You can use the Status Window to pause, resume, or delete the current print job, and you can access on-line help for the Microsoft Windows Printing System.

While you are working in the Status Window, remember that you can get on-line help at any time by choosing commands from the Microsoft Windows Help menu or by pressing **F1**.

- When you install the Microsoft Windows Printing System into Microsoft Windows 3.1 or Microsoft Windows for Workgroups 3.1, the Print Manager helps you control and manage all print jobs in a queue for all printers installed for Microsoft Windows.
 - When your computer is connected to a network printer, the "Status Not Available Network Printer" message always appears in the Status Window. That is, you cannot check the status of the printer or control the printer, except to print a test page. The Status Window for the network printer appears on the network printer server, which is connected locally to the printer.
-





Using the Status Window

The Status Window uses animated 3-D graphics to illustrate the printer and the document being printed.

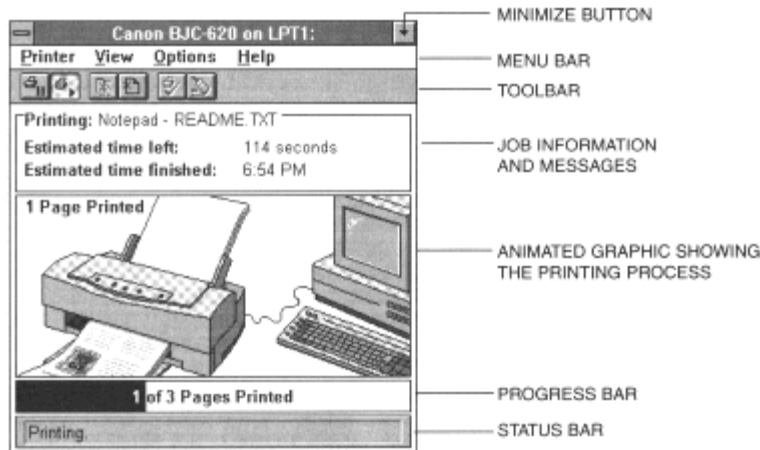

Opening the Status Window

The Status Window opens automatically in the following cases:

- When you print with the Microsoft Windows Printing System-unless you previously turned off the Display Printer Status While Printing option (see page 2-18).
- When the Microsoft Windows Printing System encounters an alert that requires your intervention before you continue printing (see page 2-17).

The Status Window always opens the way you left it last, either full size or as an icon that indicates the general condition of the printer (printing, idle, and so on).



Note

When you install the Microsoft Windows Printing System into Microsoft Windows 3.1 or Microsoft Windows for Workgroups 3.1, the Print Manager is enhanced and you can open the Status Window by clicking the printer info button on the toolbar in the Print Manager.





Using the Toolbar

The toolbar has six buttons:



Pause Printing

To temporarily halt printing the current document, click this button. The Microsoft Windows Printing System finishes printing the current page, but will not print the remaining pages until you click the Resume Printing button.



Resume Printing

To continue printing after a pause, click this button.



Force Printing

To force printing of the current print job, click this button. The Microsoft Windows Printing System forces printing on a paper size that is different from the one originally selected for the document.



Cancel Printing

To cancel printing the current print job, click this button.



Print Test Page

To print the test page, click this button.



Quick Clean

To clean the print head unit, click this button. The printer performs Quick Cleaning. See Chapter 4, *Maintaining the Printer*; for details.

Using the Status Window as an Icon

You can make the Status Window appear as an icon by clicking on the Minimize button in the upper right corner of the window. The icon tells you all you want to know about the print job.

A progress bar appears above the icon when a document is printing. When the job is finished, the icon changes to show a stack of printed pages. Other icons indicate when the printer is idle, when the Microsoft Windows Printing System has detected a condition that requires either your eventual or immediate attention, and when the status of the printer is not available.





Printer Ready

When the printer is ready, the icon looks like it does during printing, but without the progress bar.



Printing Done

When the printing has finished, a stack of pages appears on the printer.



Printing Paused

When printing is paused, the icon shows a **II** mark.



Printer Warming Up

When the printer is preparing for printing, the icon shows an hourglass.



Information

When the Microsoft Windows Printing System has an information message, the icon shows a large (i) and blinks to get your attention. To read the text of the message, restore the Status Window to its full size.



Attention Required

When the Status Window displays an alert, the window automatically opens to its full size. You can, however, minimize the window to an icon showing the exclamation mark (!) that identifies an alert.



Even if you minimize the alert, you will not be able to resume printing until you take the action specified in the full-size window.





Messages Displayed in the Status Window

The Microsoft Windows Printing System gives you complete information about your print job and the printer itself. There are three categories of messages:

-  Information messages notify you of a condition that does not require immediate action.
-  Alerts require your intervention before printing can proceed.
-  During operations such as print head cleaning, messages inform you that the printer is preparing for printing. When these messages appear, wait for a moment.

Other messages, such as Printer Ready, appear to keep you informed about your printer.

The messages are easy to understand and the solution to the problem is generally straightforward.

For on-line help, you can always press **F1** or use the Help menu.

If you installed the sound files, the Microsoft Windows Printing System accompanies each message with a distinctive sound or spoken message. You can turn the sounds off by using the Display Options dialog box (see the *Customizing Display Options* section on page 2-18).





Customizing the Status Window

The Status Window always displays job information. However, the View menu allows you to set the four components (Toolbar, Printer animation, Progress bar, and Status bar) to display in the Status Window.

You cannot resize the Status Window, but you can make more room on the screen by showing fewer components. For example, you could limit the Status Window to the Toolbar and the Progress bar.

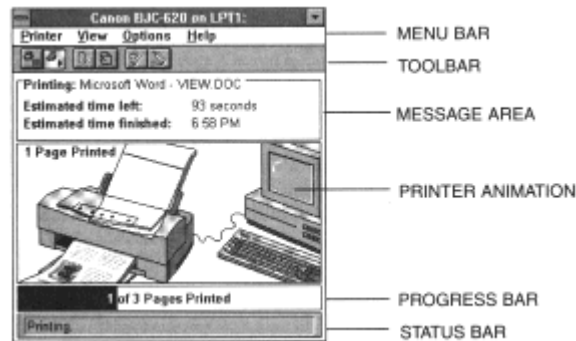

Customizing Display Options

Use the Status Options dialog box to control when the Microsoft Windows Printer System displays the Status Window and whether sound accompanies each message.

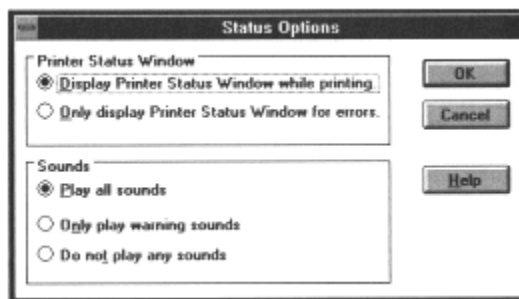



- You can open the Status Options dialog box from the Option menu in the Status Window.
- You can use the Microsoft Windows Control Panel to turn individual sounds on or off.
- You can change display options even as a document prints, but the changed settings will not take effect until the next print job.

Maintaining the Printer from the Status Window

You can perform the following operations for maintaining the printer from the Status Window:

- **Print a Test Page**
You can print the same test page as that printed out when installing the Microsoft Windows Printing System. You can check the printer and software operation by printing a test page. You can also check the condition of the print head.

Since the test page is printed with the currently selected printing options, such as Dots Per Inch or Print ~uality, you can verify the output with the settings.

- **Align the Print Head Unit**
You can align the print head unit. Print head alignment is necessary when you have print quality problems with the initial printing after installing or replacing the print head unit.
- **Clean the Print Head Unit**
You can clean the print head unit with three kinds of cleaning procedures: Thorough, quick, and Custom.

You can print a test page with the Print Test Page button and perform the quick cleaning with the quick Clean button on the Toolbar in the Status Window.

You can also perform the above operations in the Printer Options dialog box, which can be opened from the Status Window.





The Printer Options Dialog Box

You can perform the printer maintenance operations from the Printer Options dialog box.

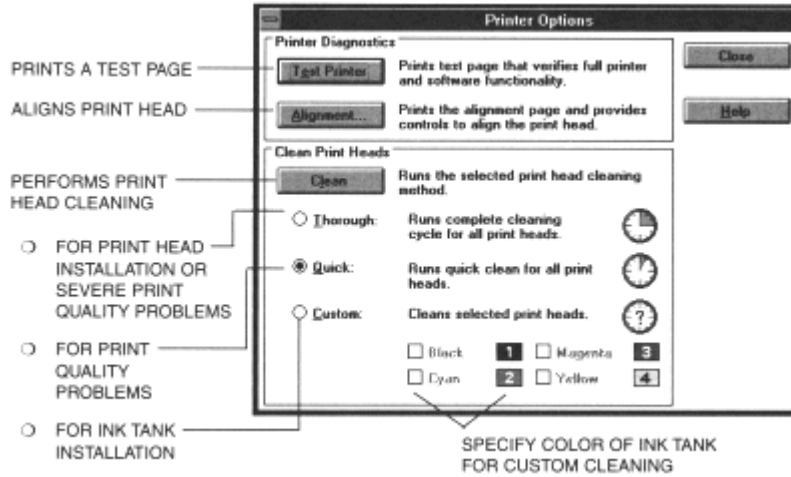

To display the Printer Options dialog box, open the Status Window and then select Printer Options... from the Options menu.



Paper Handling 3



This chapter describes how to use the printer for all your printing operations. It includes:

- Selecting paper
- Setting the paper thickness lever
- Setting the paper selection lever and the paper support
- Summary of printer settings for various print media
- Automatically feeding paper
- Manually feeding paper
- Printing on envelopes
- Using Canon's specialty papers

To ensure the best performance of your printer, you'll want to select the best paper and load it correctly. You can stack paper in the sheet feeder to load it automatically, or you can manually feed one sheet at a time. The path that the paper travels through the printer is the same for automatic and manual feeding.

Selecting Paper Types

One of the most important things you can do to assure the best possible print quality from your Bubble Jet printer is to select the correct paper. Your printer produces letter quality output on most plain bond papers, including cotton bond and photocopying papers; it does not require special ink jet papers. However, the print quality varies with different paper types. Be sure to test a type of paper before you purchase a large quantity.

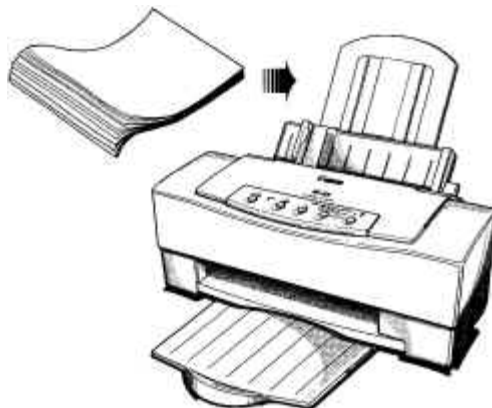

Plain Paper

The printer supports paper sizes of letter, legal, and A4 in portrait orientation. You can use regular copier paper, cotton bond papers, and typical letterhead. Always use paper without curls, folds, staples, or damaged edges.

Bubble Jet Paper (water resistant)

The Canon Bubble Jet Paper LC-301 has been developed for high quality printing with minimal or no smearing or running when in contact with water or damp surfaces, making it a good choice for damp or rainy environments. The paper is specially coated and printable on both sides.

Coated Paper

Canon's Coated Paper LC-101 is specially designed for your BJC-620 printer, which will produce sharp and vivid color output on this high grade matte paper. The coating used on this paper is a unique formula that ensures full compatibility with your Canon color inks. Use this paper for your printer output that requires crisp color rendering on a high quality, nonglossy paper.

High Resolution Paper

The Canon High Resolution Paper HR-101 is designed to produce photographic quality print output with sharp and vivid graphics.

Transparencies

Transparency CF-102 from Canon is recommended. These transparencies produce excellent contrast, sharpness, and color.

Back Print Film

Canon Back Print Film BF-102 has been specially developed for Canon Color Bubble Jet printers. The film is designed to deliver brilliant, high intensity color images suitable for business presentations, design work, or professional reports. Back print film is printed on the back (nonglossy) side of the film in mirror image and then viewed from the front or glossy side using a backlighting device. For more details, ask a Canon Authorized Dealer for information or refer to the manual supplied with the film.

High Gloss Film

The Canon High Gloss Film HG-101 features a bright white finish that lends striking visual power to charts, graphs, and photographic images. Use this film to make your presentation materials and graphics look professional.

Fabric Sheet

Use Fabric Sheet FS-101 for Canon Bubble Jet printers to print banners, pillow covers, scarves, flags, and other textile items. Use these sheets for applique and other craft and sewing projects. Fabric sheets are 9.5 x 14 inches.

T-Shirt Transfers

Use Canon's popular T-Shirt Transfers TR-101 to create and personalize T-shirts, sweatshirts, aprons, tablecloths, napkins, tote bags, and anything else your imagination allows! Use on any cotton or cotton/poly blend fabric. Your image is printed in mirror image (when you use T-Shirt Transfer mode through the BJC-620 Printer Driver) so when you iron it onto the T-shirt, the image is viewed correctly.

Greeting Cards

Get the most out of your Canon Creative or other card-making software with Canon Greeting Cards GC-101. These cards give your unique, personalized cards the look and feel of professional cards. You can create cards, invitations, announcements, and more.

Brochure Paper

Canon's Brochure Paper BP-101 is specifically designed for creating high quality brochures on glossy paper. Combined with Design Essentials from Canon Creative, you have everything you need to create professional half-fold, tn-fold, and full sheet brochures. Each glossy sheet is coated on both sides to allow manual duplex printing.



If you are printing in an application outside Windows, your software application or printer driver must support mirror image printing in order to use Back Print Film or T-Shirt Transfers.

Paper Guidelines

When selecting or loading paper, keep these guidelines in mind.

- Attempting to print on damp, curled, wrinkled, or torn paper can cause paper jams and poor print quality.
- Use cut-sheet paper only. You cannot use multipart paper.
- If the print density of your page is very high, light paper stock may curl slightly due to the large amount of ink. If you need to print heavy graphics, try printing on a heavier stock.
- Do not use thicker paper than meets the specifications for this printer. Printing with a paper that is thick enough to come in contact with the print head nozzles may damage the print head unit.
- For the best printing results, follow the instructions included with the paper.

Before Loading Paper

To ensure trouble-free paper handling, you'll want to set the paper thickness lever and the paper selection lever before loading paper.

Setting the Paper Thickness Lever

You use the paper thickness lever to adjust the distance between the print head and the paper to accommodate different paper thicknesses. This distance is called the *print gap*.

Set the lever according to the thickness of the paper you are using:

- **Down** is for printing on plain paper and normal weight (such as 20 lb) print media.
- **Up** is for printing on heavier-weight print media (such as fabric sheets) and envelopes. (See page 3-8 for details).



Paper Thickness Lever



Note

Always set the paper thickness lever before and after printing on heavier-weight print media or envelopes.

If you are printing documents with high density graphics or ink and the printed pages are smudged, try setting the paper thickness lever to the up position. This moves the print head unit further from the paper. Print quality may diminish slightly but the smudges should go away.

Setting the Paper Selection Lever and the Paper Support

Set the paper selection lever and the paper support to their proper positions before loading paper.

- When automatically loading a stack of paper, set the paper selection lever to the back position and extend the paper support.

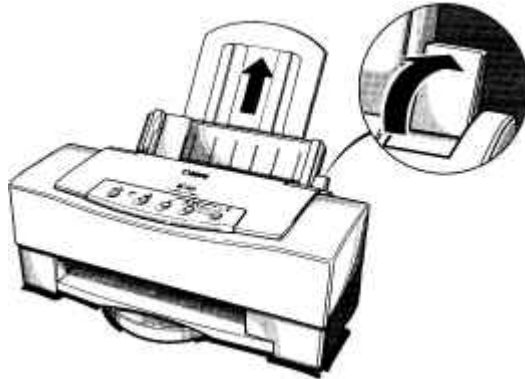

- When automatically loading a stack of envelopes, set the paper selection lever to the front position and extend the paper support.

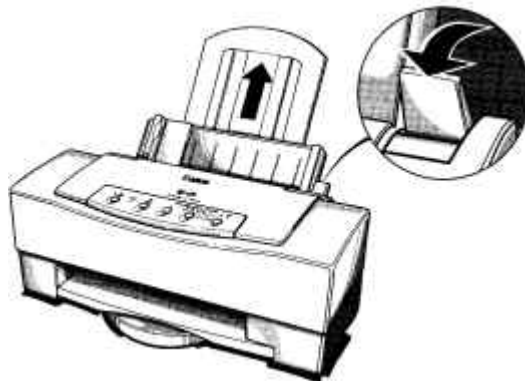

- When manually feeding any type of print media, set the paper selection lever to the front position and lower the paper support.

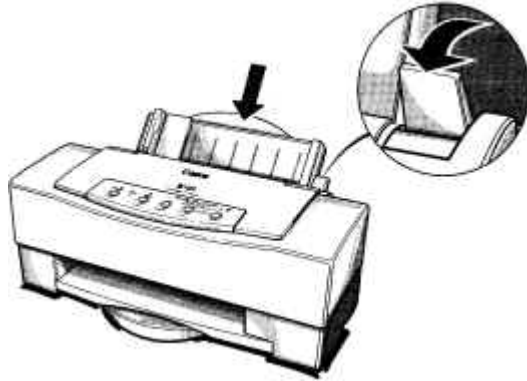

- Do not move the paper selection lever after loading paper in the sheet feeder.
- This lever is different than the lever on a typewriter or dot matrix printer. You need not pull it forward to load paper. You set the paper selection lever to the front position only when loading envelopes or when manually feeding paper. If it is set to the front position when you are automatically feeding stacks of normal paper, the printer may feed multiple sheets or jam.

When the paper selection lever is in the back position, a lever inside the printer prevents the paper from advancing into the printer. When you move the paper selection lever to the front position, the lever inside the printer moves so that the single sheet being manually fed can advance into the printer.

Printer Settings for Various Print Media

The following table summarizes the printer settings for the various types of print media:

Paper type	Paper thickness lever	Paper selection lever	Paper support	Loading method	Stack (sheets)
Plain paper	Down	Back	Up	Automatic	100
Bubble Jet Paper (LC-301)	Down	Back	Up	Automatic	100
Coated Paper (LC-101)	Down	Back	Up	Automatic	80
High Resolution Paper (HR-101)	Down	Back	Up	Automatic	80
Transparency (CF-102)	Down	Back	Up	Automatic	50
Back Print Film (BF-102)	Up	Back	Up	Automatic	50
High Gloss Film (HG-101)	Down	Front	Down	Manual	1
Fabric Sheet (FS-101)	Up	Back	Up	Automatic	1
T-Shirt Transfers (TR-101)	Up	Front	Down	Manual	1
Greeting Cards (GC-101)	Up	Front	Down	Manual	1
Brochure Paper (BP-101)	Up	Front	Down	Manual	1
Other heavier weight print media	Up	Front	Down	Manual	1
Envelopes					
Stacked	Up	Front	Up	Automatic	15
Single	Up	Front	Down	Manual	1

Automatically Feeding Paper

You can place approximately 100 sheets of plain paper or Bubble Jet paper (17 lb or 64 g/m²) in the sheet feeder at a time.

You can stack approximately 50 sheets of transparency film, back print film, or high resolution paper in the sheet feeder. However, these special print media may not advance correctly under unusual environmental conditions (such as extreme temperatures and humidity). If you have trouble with special papers becoming skewed or feeding multiple sheets, do not stack them in the sheet feeder. Load them manually as described later in the chapter (page 3-15).

To automatically feed plain paper, follow these steps:

1

Make sure the paper thickness lever is down for printing on plain paper.



Paper Thickness Lever



2

Make sure the paper selection lever is set to the back position



3

Extend the paper support and paper output tray.

- Pull the paper support up until it stops. The paper support keeps paper straight and limits the possibility of jams.
- Extend the paper output tray.





4

Fan the paper.

- For best results, fan the paper before loading it.
- Always fan a stack of paper along the edge that will feed into the printer first.



5

Slide the stack of paper into the sheet feeder until it stops.

- Align the edge of the paper with the right edge of the sheet feeder.
- Do not force the paper into the printer.
- Insert the paper so that the side you want to print on is facing you. If you are using a preprinted stock, such as letterhead, insert the top of the paper into the sheet feeder first.
- Make sure the stack of paper does not exceed the paper limit mark on the right side of the sheet feeder.

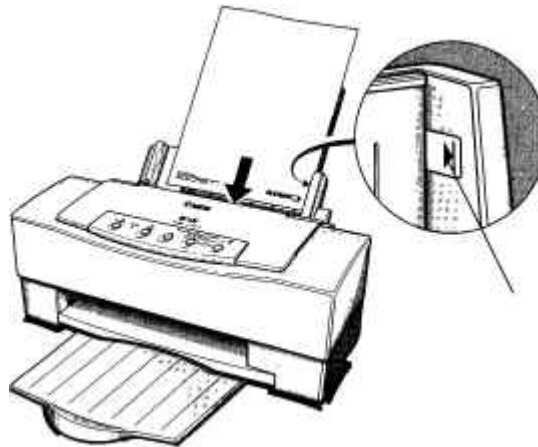



6

Adjust the paper guide to the stack of paper.

- This keeps the paper feeding straight into the printer and reduces skewing.
- Be sure there is no gap between the paper guide and the edge of the stack of paper.

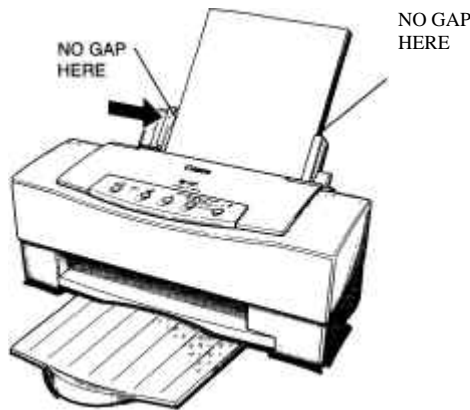

7

Start printing.

- Make sure the printer is turned on and on-line.
- Start your print operation.





Auto Feed Guidelines

When automatically feeding stacks of paper, follow these guidelines.

- Do not leave paper stacked in the printer for long periods of time; longer sheets of paper may become bent or curled over time. This may cause the paper to misfeed or jam.
- If your printed page contains lots of graphics, the ink on the page may be damp due to the print density. Remove the page right away and allow the ink to dry.
- The capacity of the paper output tray is 20 sheets of paper. To reduce paper jams, remove paper from the output tray before the count reaches 20.
- If paper curls after printing, remove it immediately; otherwise, paper jams may occur.
- The platen (a roller on the inside of the printer) may become inked if you print data beyond the width of the page. If this happens, clean the platen with a soft cloth. (For details on cleaning the platen, see Chapter 4, Maintaining the Printer.)
- Depending on the density of your printed pages, the ink may need time to dry. Within two to three seconds, the ink becomes smudge resistant.
- Do not try to load paper into the sheet feeder beyond the paper limit mark on the right side of the sheet feeder; stacking too much paper may cause paper feeding or printing problems.



Limit Mark





- Make sure there are no gaps between the stack of paper and the paper guide nor the right edge of the sheet feeder.



- When automatically feeding transparencies or back print film, remove each sheet after it is delivered. Do not allow film sheets to stack up in the paper output tray.
- Place at least one sheet of plain paper in back of a stack of transparencies or back print film to avoid paper jams and misfeeds.
- Let the printed sheets of film dry completely before storing them. The complete drying time required for color printing on Canon's transparencies or back print film is approximately 15 minutes. The complete drying time required for solid black printing on this media is approximately 30 minutes. You may be able to reduce the drying time if you reduce the density setting in your application before printing.
- If printing at 720 x 720 dpi in black on back print film appears blurred, switch to 360 x 360 dpi or reduce the density setting in your application.
- If printing in black on transparencies is not as crisp as you expected, reduce the density setting in your application.





- When a sheet of film has dried completely, cover its printed side with a sheet of plain (not coated) paper before storing it; this is recommended even if you place the sheets of film in a clear file.

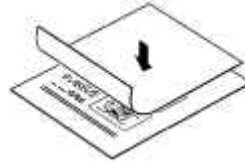

For best results when printing on special papers, follow the instructions that come with the paper.

Manually Feeding Paper

You use the manual feed function when printing on heavier-weight print media (24 lb to 28 lb or 91 g/m² to 105 g/m²) or high gloss film.

To manually feed a single sheet, follow these steps:

1

Make sure the printer is turned on and on-line.

- The POWER, ON LINE, and PRINT MODE lights are on.

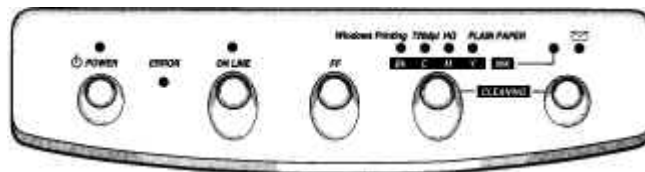



2

Open the top cover and check the paper thickness lever.

- If you are manually feeding heavier-weight print media, set the paper thickness lever to the up position. (See page 3-8 for details).
- If you are printing normal weight (20 lb) print media, set the lever down.



PAPER THICKNESS LEVER

3

Set the paper selection lever to the front.

- Make sure the paper support is lowered.

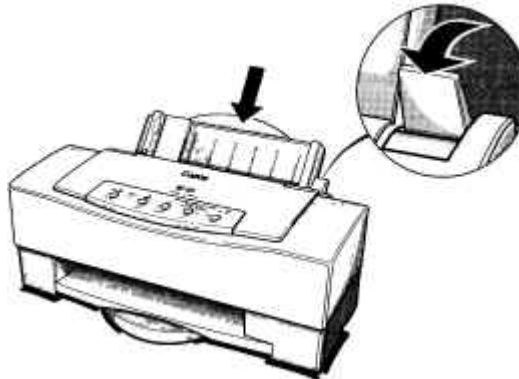



4

Insert the
single sheet.

- Slide in the paper until it stops inside the sheet feeder.
- Align the sheet with the right edge of the sheet feeder.
- Adjust the paper guide to the sheet.



5

Start printing.

- Be sure to select Manual Feed in the Setup dialog box of the Microsoft Windows Printing System.
- Make sure the printer is on-line.
- Start your print operation.



Note

- After printing on heavier-weight print media or envelopes, set the paper thickness lever (inside the printer) to the down position before printing on normal paper.
- After manually feeding a sheet of paper or an envelope, set the paper selection lever to the back position.





Printing on Envelopes

You can stack up to 15 envelopes in the sheet feeder or you can manually feed envelopes one at a time.

U.S. Commercial number 10 (COM 10) envelopes and European DL envelopes are recommended. You may be able to stack envelopes of other sizes in the sheet feeder; however, Canon cannot guarantee consistent performance on envelope sizes other than COM10 and DL.

The following envelopes are not recommended because they may cause jams or smears, or may damage your printer.

- Envelopes with windows, holes, perforations, cutouts, and double flaps.
- Envelopes made with special coated paper or deeply embossed paper
- Envelopes using peel-off sealing strips.
- Envelopes in which letters have been enclosed.

Preparing Your Software

How you create envelopes within your software application depends on the application. See your application's documentation for details.

If you are using the Microsoft Windows Printing System, change the Paper Size setting to #10 or DL.

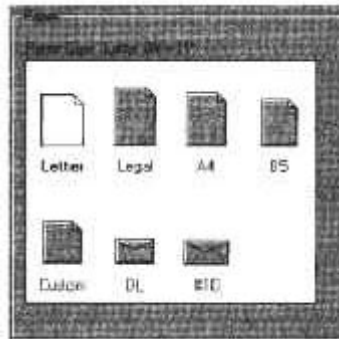



Check your software to see if it prints envelopes in portrait or landscape orientation. It's a good idea to print on a sheet of paper before printing on an envelope to check the orientation.



Note

Printing on envelopes in portrait orientation results in faster printing. However, several software packages, such as WordPerfect® and Word for Windows, default to landscape orientation. This requires adjustments in the software to correctly print on envelopes with this printer. See your software documentation for details.

Loading Envelopes

When you are ready to print on envelopes, follow these steps to stack envelopes in the sheet feeder. (You can also manually feed envelopes one at a time.)

1

Set the green paper thickness lever to the up position.

- The lever points upward.

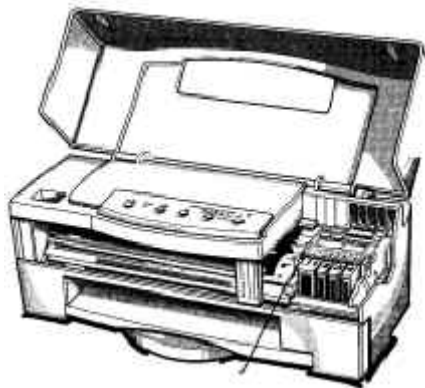

PAPER THICKNESS LEVER





2

Set the paper selection lever to the front.

- Make sure the paper support is extended.
- Move the paper guide to the left to match the width of the envelopes.

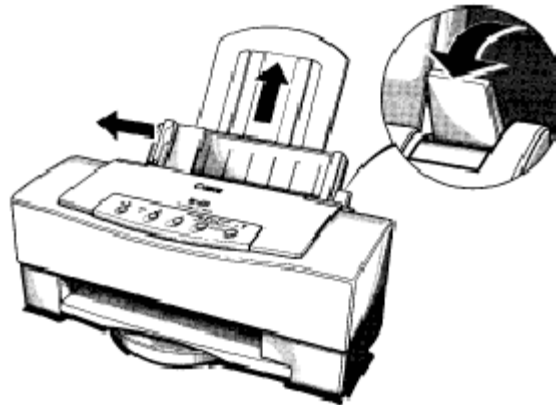

Prepare the envelopes

- Arrange the stack of envelopes on a firm surface and press down firmly on the edges to make the folds crisp.
- Press around the envelopes to remove any curls and expel air from inside the envelopes.
- Press firmly on the area that corresponds to the edges of the flap.

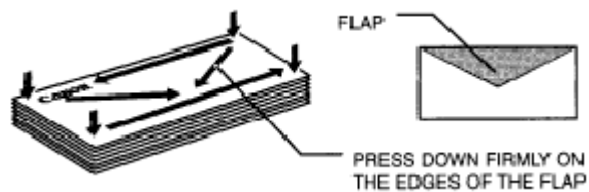



4

Insert the envelopes.

- Slide a stack of envelopes into the sheet feeder until it stops
- Align the stack of envelopes with the right edge of the sheet feeder.



5

Adjust the paper guide to the stack of envelopes.



6

Start printing.

- Make sure the printer is on-line.
- Start your print operation.





Note

When printing on COM10 envelopes, move the paper guide all the way to the left. Depending on the size and shape of your interface connector, the paper guide may touch it. If this causes the envelopes to misfeed, use an interface cable with a smaller connector.

Using Canon's Specialty Papers

This section describes how to use the cleaning sheet that comes with the Canon High Resolution Paper and how to use the Fabric Sheets for Canon Printers.

Canon's High Resolution Paper HR-101

Canon's High Resolution Paper HR-101 is designed for high quality printing. This paper is specially coated to produce delicate color output. After using a package of High Resolution Paper (200 sheets), you need to use the cleaning sheet enclosed with the paper to remove paper dust from the printer's rollers; this will help prevent paper feed problems.

Using the Cleaning Sheet

1

Set up
the
printer.

- Make sure the paper thickness lever (inside the printer) is down-for normal paper.
- Make sure the paper selection lever is to the front and the paper support is lowered-for manual feed.
- Make sure the paper output tray is extended.





2

Insert the
cleaning sheet.

- Remove the two pieces of tape from the sheet.
- Insert the sheet with the sticky side out (toward you) and down (going into the sheet feeder).
- Adjust the paper guide to the edge of the cleaning sheet.



3

Feed the
cleaning sheet.

- Turn off the printer by pressing the POWER button.
- Press and hold the FF and PRINT MODE buttons and press the POWER button until the printer beeps.
- The printer advances the cleaning sheet and starts cleaning.
- The printer feeds the sheet and then ejects it.
- Use a cleaning sheet once only.



Fabric Sheets FS-101

Fabric sheets FS-101 for Canon printers come with a booklet that describes special handling procedures. Be sure to look through this booklet for special information regarding the Fabric Sheets. This section describes specific steps for using Fabric Sheets with the BJC-620.

Be sure to follow these guidelines.

- To avoid paper jams, smearing, and other problems, do not open the printer's cover during printing.
- Use the fixing agent that comes with the Fabric Sheets FS-101.
- Do not touch newly printed fabric sheets until the ink is completely dry. This takes about one hour.

Printing On a Fabric Sheet

1

Set up
the
printer.

- Make sure the paper thickness lever (inside the printer) is up for heavier-weight print media.
- Make sure the paper selection lever is to the front and the paper support is lowered for manual feed.
- Make sure the paper output tray is extended.

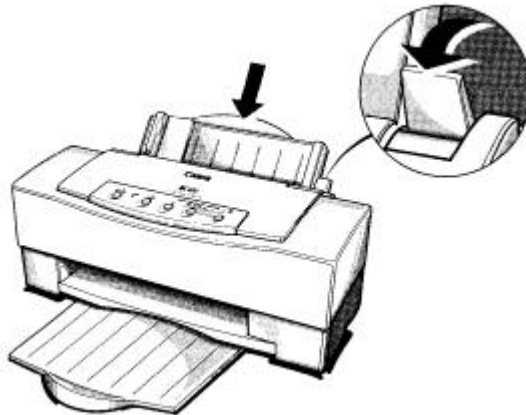

Maintaining the Printer 4



This chapter covers the care and maintenance required for your Canon BJC-620 Color Bubble Jet Printer. It includes:

- Printer guidelines
- Cleaning the printer
- Cleaning the print head unit
- Replacing an ink tank
- Replacing the print head unit
- Transporting the printer

Printer Guidelines

Follow these guidelines to avoid damage to your printer and harm to you or others:

- Set the printer on a stable surface. Do not use an angled printer stand. Avoid setting the printer in direct sunlight.
- Keep the front cover closed when printing.
- Do not set anything on top of the printer.
- Always use a three-wire, grounded power receptacle (electrical wall outlet with three holes) for your printer's power cord. Do not modify the cord or remove the ground pin.
- Make sure the power is off any time you connect or disconnect the power cord or interface cable.
- When unplugging the power cord, always remove it by holding the plug and not the cord.

- Do not unplug the printer unnecessarily. The printer may clean the print head nozzles and consume a small amount of ink when you plug it into an AC outlet or a power strip.
- Never unplug the printer or turn off a power strip to which the printer is attached when the printer's power is turned on. This may prevent the print head unit from returning to the home position. Once in the home position, the print head unit and the ink tanks are capped, which prevents them from damage or drying out. This is critical. If left uncapped, the print head unit may clog and may need to be replaced.
- For reliable data communications between your computer and the printer, use a short cable, six feet or less in length. The cable must be bi-directional.
- Do not move the mechanism that holds the print head unit and ink tanks. Attempting to move the carriage may damage delicate mechanical parts.

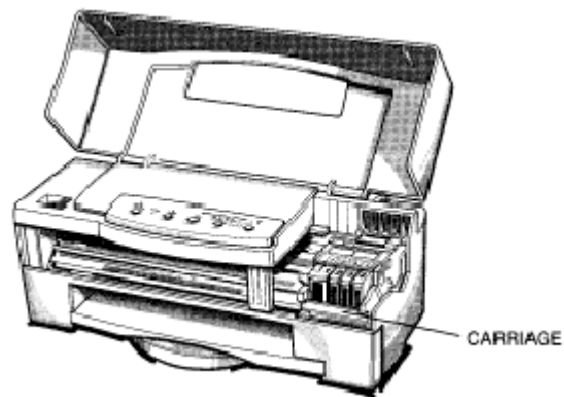

- Do not touch the print head nozzles on the print head unit. Ink may leak out and cause stains. Also, you may permanently damage your print head unit, which would require you to purchase a replacement.
- Do not touch the white padding inside the ink tank. Ink may leak out and you may damage the tank.

Cleaning the Printer

Your printer requires little routine maintenance. Perform the following maintenance, as necessary, to keep your printer in good operating condition.

Be very careful when cleaning the printer. Make sure the printer is turned off; then unplug it.

1

Clean the platen and its surrounding area inside the printer

- Use a soft cloth to remove any ink mist or paper debris.
- Do not rub the gear wheels.
- Do not use any oil or cleanser inside the printer.
- When cleaning inside the printer, avoid the area near the print head unit and ink tanks. Do not touch the print head nozzles. Ink may leak out and cause stains.
- Do not move the print head unit from the home position.
- Do not use paper products (such as paper towels or tissues) to clean the inside of the printer. They may leave paper particles inside the printer.

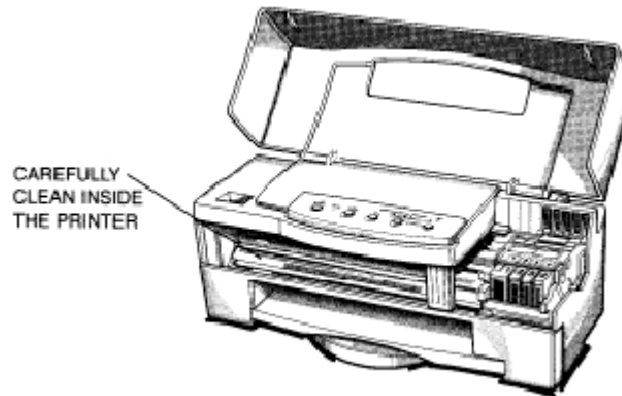

Clean the exterior of the printer.

- Use a soft cloth moistened with water.
- Clean any smudges or dust.
- Do not clean the exterior of the printer with volatile liquids such as thinners, benzine, or any spray-type or chemical cleaners; doing so will damage the surface of the printer.

Cleaning the Print Head Unit

The print head unit contains nozzles through which color ink is propelled onto the paper. The print head nozzles must be free from paper particles and dust in order to maintain a high level of print quality.

The printer has an automatic cleaning function that clears away paper particles and dust when you turn on the printer after it has been turned off for a certain period of time.

You need to activate the print head cleaning procedure whenever you replace the print head unit or individual ink tanks, or when your print quality is poor. There are three types of print head cleaning:

- **Thorough cleaning of all print head nozzles**
A new print head unit needs to be cleaned to ensure the best possible print quality. Also, you must perform a thorough cleaning if you insert the ink tanks in the wrong slots or if quick cleaning does not solve your print quality problems. This procedure takes about three minutes.
- **Quick cleaning of all nozzles**
Use this method to improve print quality. This cleaning takes about two minutes.
- **Custom cleaning of selective print head nozzles**
Use this method to clean the print head nozzles of a new ink tank or if one color is not printing as clearly as you think it should. This cleaning takes about one minute.

Using the Microsoft Windows Printing System

When you use the Microsoft Windows Printing System, perform the print head cleaning from the Printer Options dialog box. See page 2-20 for details.

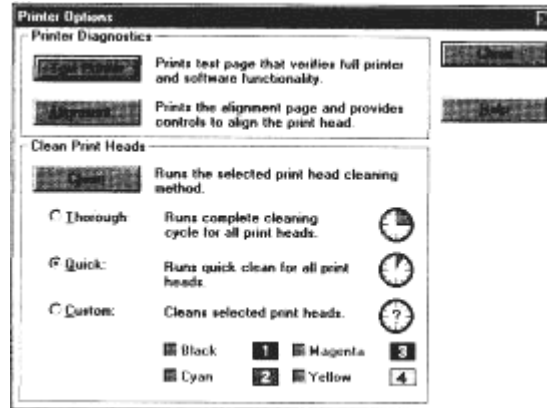

Using the Operator Panel

If you are not using Microsoft Windows, you can select the print head cleaning method from the printer's operator panel. When you press the **PRINT MODE** button repeatedly, you cycle through the cleaning types as follows:

Indicator lights

Bk	C	M	Y	Cleaning type
*	*	*	*	Thorough cleaning
●	●	●	●	Quick cleaning of all four heads
●	○	○	○	Custom cleaning of black print head
○	●	○	○	Custom cleaning of cyan print head
○	○	●	○	Custom cleaning of magenta print head
○	○	○	●	Custom cleaning of yellow print head
○	○	○	○	Cancel cleaning selection process

●: On ○: Off *: Blinking

Start cleaning

Make sure the printer is turned on.

1

Press the
PRINT MODE
and 
buttons at the
same time

- Hold these buttons until the printer beeps and the INK and  lights
- Press the **PRINT MODE** button until the appropriate lights are c

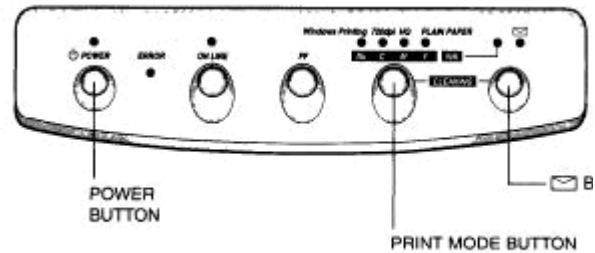

2

Press the 
buttons until the
printer beeps

- The printer starts the selected print head cleaning procedure.
- When the print head cleaning procedure is complete, the indicator



Note

To cancel the print head cleaning selection process, press the **PRINT M**
are off. Then press the button.

Ink Tank Guidelines

Use only the BJI-201 ink tanks with this printer.

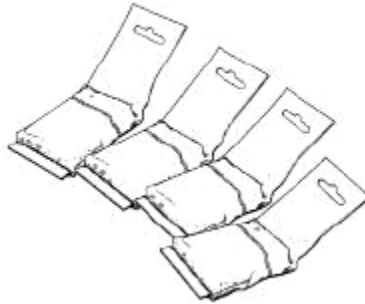

To ensure excellent print quality and to avoid spilling ink, always follow these guidelines:

- Be sure to install all four ink tanks. Attempting to print without one or more of the ink tanks in place causes the **ERROR** and **INK** lights to come on and the printer does not operate.
- Always install the ink tanks in the correct slots. If you install an ink tank in the wrong slot, the color inks may mix with each other in the printer and the new ink tank may be spoiled.
- Do not remove an ink tank until it is empty or six months after opening it, whichever comes first.
- Do not attempt to move the mechanism that houses the print head unit and ink tanks.
- Each ink tank has a sponge portion, and the top of the sponge is always white. This is normal and does not indicate a partially full tank.
- The ink inside the tanks appears much darker than the color that prints on a sheet of paper.



The contents of an ink tank may leak. Spilled ink may permanently stain any surface or object. Open ink tank packages carefully; follow all instructions on package and use all necessary precautions.

To avoid spilling ink, follow these precautions:

- Do not attempt to disassemble or refill an ink tank.
 - Do not vigorously shake an ink tank while handling it.
 - Do not stick anything into the opening on the ink tank.
 - Do not unpack an ink tank until you are ready to install it.
-



Note

Canon's limited warranty does not cover damage that is attributable to the use of third party parts or supplies, including inks. The limited warranty remains in effect for its life once that particular damage has been properly repaired.

Replacing an Ink Tank



Caution

Canon makes numerous ink tanks; the BJI-201 ink tanks are designed specifically for the BJC-620 Color Bubble Jet Printer and are the only ones Canon recommends that you use.



Make sure
the printer
is turned on
and on-line

- Press and hold the **ON LINE** button until the printer beeps.
 - This caps the print head unit.
-

2

Open the
printers
cover.

- Grasp each side and lift up.

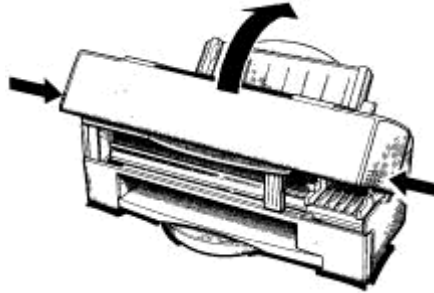

Note

Do not open the print head unit compartment cover inside the printer. You can easily remove and install the ink tanks with this cover closed.

3

Remove the
old
ink tank.

- Lift up the front of the old ink tank and slide it out of its slot.
- Dispose of it properly. You may want to place it in a plastic bag to keep from spilling any ink.

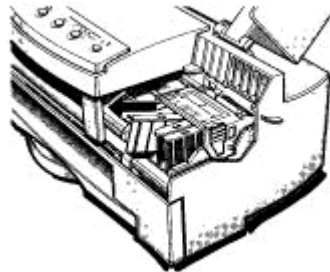

Note

If the ink tank appears to contain ink, reinstall it making sure it is seated correctly. Perform the single-head cleaning procedure for the ink tank. If the ERROR and INK lights still come on, replace the ink tank.

4

Open the new ink tank by following the instructions on its package.

- Carefully remove the new ink tank.
- Be very careful--if you spill any ink, it may be very difficult to remove.

5

Slide the new ink tank into its slot.

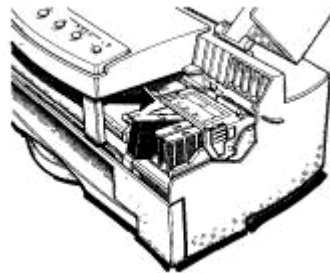

6

Press down on the top of the ink tank.

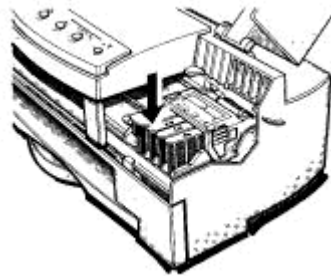

Do not attempt to move the mechanism that houses the print head unit and ink tanks

7

Check each
ink tank.

- Make sure each ink tank is correctly seated in its respective slot.
- Close the printer's cover.
- Press **ON LINE** to set the printer back on-line.

8

Perform the
custom cleaning
procedure for the
new ink tank you
just installed.

- If you are using the Microsoft Windows Printing System, see page 2-20.
- If you are not using the Microsoft Windows Printing System, see page 4-5 for details.



Caution

Be sure all four ink tanks are properly installed. If you attempt to print without one or more of the ink tanks in place, the **ERROR** and **INK** lights come on and the printer does not operate.

When you turn off the printer, the print head unit moves to the *home position* on the right and caps each ink tank. This keeps the ink tanks from drying out. The print head nozzles will not be properly capped and the print head unit may clog or be permanently damaged in the following cases.

- If you unplug the printer while it is printing.
- If you turn off a power strip to which the printer is attached while it is printing.
- If you move the print head unit from the home position.



Note

If, after installing a new ink tank, the printer seems to be printing but one or more of the ink colors does not appear, stop the print operation. Make sure the ink tanks are seated properly in the correct slots. If necessary, clean the print head unit as described earlier in this chapter.

Replacing the Print Head Unit

With proper use, the print head unit should last the life of the printer. Eventually, however, as the print head unit wears out, the print quality will deteriorate and you will see irregular or missing dots on printouts. If this occurs and print quality does not improve with repeated print head cleanings, contact the Canon Computer Systems Customer Care Center to find out your service options (see page 1-3).

Print Head Unit Guidelines

The most important thing you can do to extend the life of your BJC-620 and to ensure optimum print quality is to take care of the print head unit. To avoid damaging the print head unit, follow these precautions:

- Do not touch the print head nozzles on the print head unit or the sharp edges around them.
- Do not place the print head unit on a table with the print head nozzles facing down. Make sure the filters are facing up if you must set the print head unit down.
- Install the print head unit immediately after you open it.
- Replace an empty ink tank as soon as possible. Do not attempt to print a color for which the ink tank is empty.
- Do not use heavier-weight print media than meet the specifications for this printer. (See Appendix A, *Specifications*, for details.) Printing with a paper that is thick enough to come in contact with the print head nozzles may damage the print head unit.

Removing the Used Print Head Unit

Remove the print head unit only when you have a new one available (otherwise your ink tanks may dry out). To remove the used print head unit, follow these steps:

1

Turn off the
printer

- Open the printer's cover.
- Remove the four ink tanks and set them aside for now.
 - Be sure to set them upright on a level surface with their number labels facing up.
 - Do not remove the print head yet.
- Close the cover

2

Turn on the
printer

- Press and hold down the **FF**, **PRINT MODE** and  buttons and press the **POWER** button until the printer beeps. This empties the ink from the print head unit.
- Open the printer's cover.

3

Open the
compartment
cover.

Press in on the tabs on the sides of the cover and lift it up.

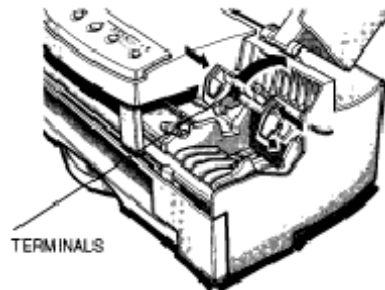



Note

Do not touch the terminals on the inside of the compartment cover.

4

Remove the print head unit.

- Dispose of it properly.
- Follow local guidelines for disposal.

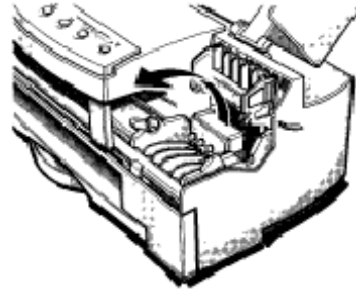

Installing a New Print Head Unit

Make sure the power cord is attached and the power is off.

1

Take the new print head unit out of its protective packaging.

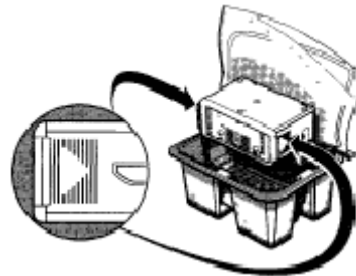

2

Remove the white tape from the print head unit.

- Do not remove the gray-padded material around the silver filters.
- Avoid touching the terminals, print head nozzles, and silver filters on the print head unit.
- The print head unit contains a clear liquid preservative that is harmless; if it leaks onto your hand, wash it off.

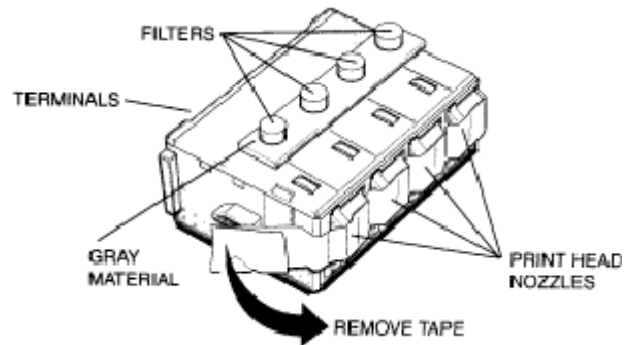

3

Insert the print head unit.

- Gently place the print head unit into the compartment with the print head nozzles down, the terminals up, and the silver filters facing the front of the printer.
- You don't need to press on the print head unit. When you close the compartment cover, the print head unit becomes secure.

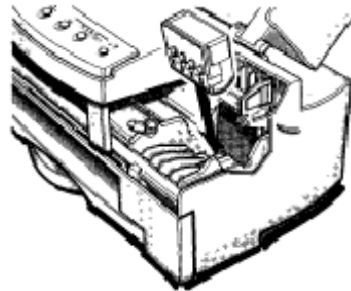

4

Close the
compartment
cover.

- Press down firmly on the two white dots on the top of the cover until it snaps securely closed.
- You actually hear two distinct clicks as the cover engages with the compartment base.
- Make sure the sides of the gray compartment cover touch the black base of the print head compartment.

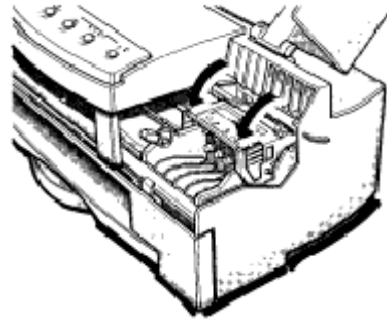

5

Reinstall the
ink tanks you
removed earlier.

- Be sure to insert the tanks into the correct slots.

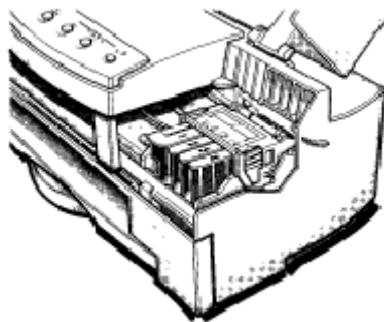

6

Close the printer's cover, and turn on the printer.

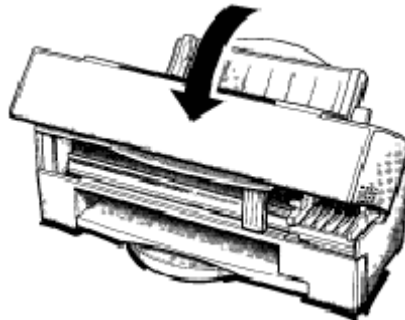

7

Complete installation.

- Perform the thorough print head cleaning procedure.
 - If you are using the Microsoft Windows Printing System, see page 2-20.
 - If you are not using the Microsoft Windows Printing System, see page 4-5 for details.
- Print the test page to check the nozzle pattern.
 - If you are using the Microsoft Windows Printing System, see page 2-20.
- Print the alignment page to select the best horizontal registration for printing.
 - If you are using the Microsoft Windows Printing System, see page 2-20.
- If you turn on the printer and the orange ERROR light flashes, see the *Initializaton Error* section on page 5-3 for details.

Transporting the Printer



- While the BJC-620 Color Bubble Jet Printer is small and compact, it is not a portable printer and you need to take care when transporting it. The printer's components, such as the sheet feeder, may become damaged if subjected to severe vibration during transportation. Also, your print head unit may dry out during travel (and become unusable) if it is not capped correctly and the ink tanks may spill if they are not taped correctly.
 - The printer is intended for use with a 120V power source only. Canon does not recommend using the printer with any other power source or with a transformer.
-

If you plan to move the printer from one location to another, or if you want to store it, follow these steps.



Press the **POWER** button to turn off the printer.

- Open the cover and make sure that the print head unit is in the home position.
- If the carriage does not return to the home position because of a printer error, manually move it to the home position.

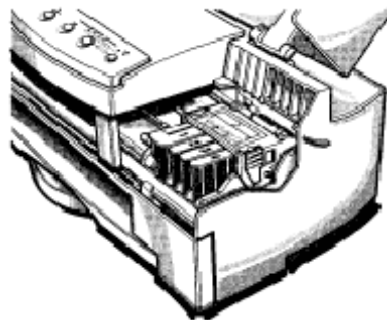

2

Remove all four ink tanks.

- Wrap the ink tanks individually with clear plastic wrap or a similar material.
- Then, pack them together in a plastic bag to avoid spilling any ink.

3

Close the printer's cover.

- Press and hold the **FF**, **PRINT MODE**, and  buttons and press the **POWER** button until the printer beeps. This empties the ink from the print head unit.
- Remove any paper from the sheet feeder.
- Detach the interface cable and the power cord.
- Open the printer's cover again.

4

Secure the cartridge holder to the printer with tape.

- Use tape strong enough not to detach or break during transportation.

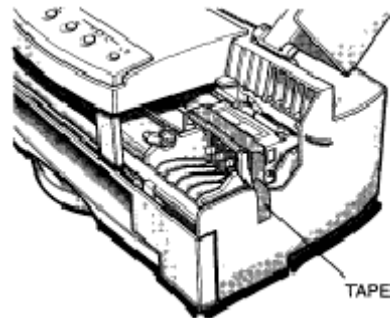

5

Return the paper support and paper output tray to their original positions.

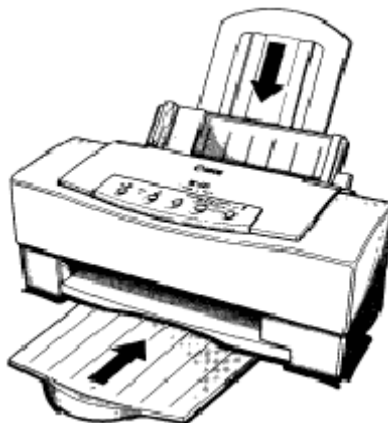

6

Secure the top cover, paper guide, and the paper support with tape.

- Replace the piece of plastic that protects the sheet feeder.

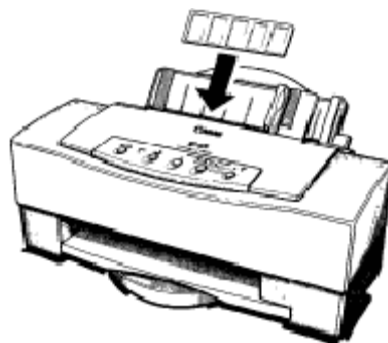

7

Repack the printer in its original packing materials.

- Store the ink tanks in the box with the printer.

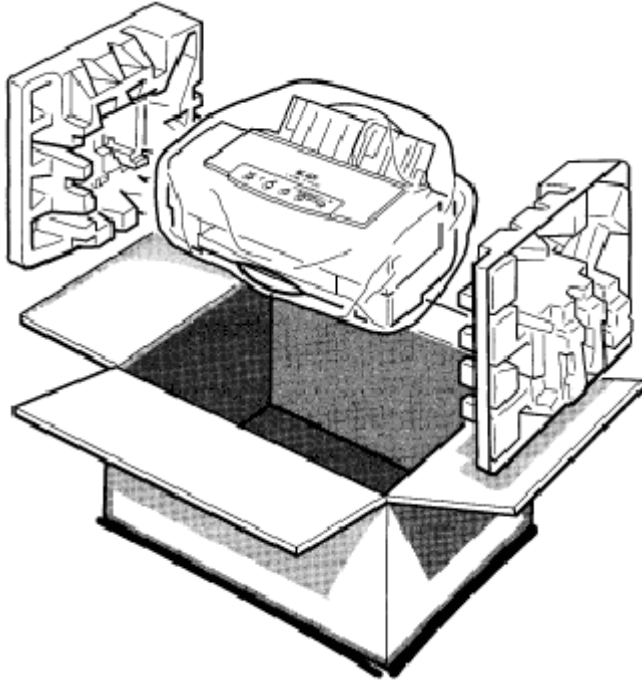

Troubleshooting

5



Due to today's rapidly changing personal computer environment, we have placed troubleshooting information in a variety of places to ensure that the most accurate information possible is available. The best way to find current information is through our on-line support services and through our Fax Retrieval System. On-line services include the World Wide Web, our BBS, and CompuServe.

This chapter contains very basic information to help solve printer problems. It describes how to use Canon's various support services, covers a few basic problems, and describes how to clear a paper jam. It also includes troubleshooting information regarding the Microsoft Windows Printing System.

Using Canon's Support Services

This section describes where to look for help. For information on the numbers for these services, see *Getting Help from Canon* in Chapter 1 (page 1-3).

- If you have an operational problem:
 - Look through the Windows Printing System on-screen Help for related information.
- If you have a need for a unique printer driver:
 - Contact Canon through the Web, its BBS, or CompuServe.
- If you are an MS-DOS user (and do not have Windows):
 - Use Canon's Fax Retrieval System to obtain information regarding how to use the printer with your MS-DOS applications.
- If you have a hardware problem:
 - Call the Customer Care Center.

Identifying Your Printer Problem

Before contacting Canon, identify your printer problems and make sure you have the following information:

- Product name - BJC-620
- Serial number
- Place of purchase
- Nature of problem
- Steps you have taken to solve the problem and the results

The serial number is located on the label on the back of the printer:

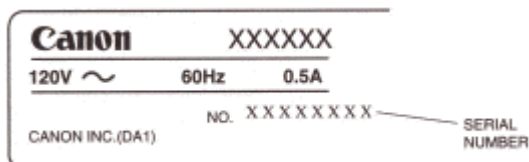

Attempting to repair the printer yourself may void the limited warranty as to that repair. See the limited warranty information at the back of this manual for details.

General Problems

The most basic problems you may encounter are "the printer does not print" and "your print quality is not satisfactory."

- **If the printer does not print**
 - Check all your cable connections
 - Check your Microsoft Windows Printing System setup
 - Check your computer configuration
- **If your print quality is not satisfactory**
 - Clean the print head unit
 - Clean the print head unit five times
 - Replace the ink tanks

Initialization Error

The first time you turn on the printer, it performs an initialization process and flushes the print head unit to make sure the nozzles are clear. This takes approximately three minutes. It is done only once - the first time you turn on the printer.

As the printer flushes the print head unit, various lights flash and then stay on. These lights indicate where the printer is in the cleaning process.

If a print head unit error occurs when you turn in the printer, the orange **ERROR** light and one or more **PRINT MODE** lights flash. Follow these steps:

1

Turn off
the printer

- Press the **POWER** button to turn off the printer.
- Unplug the printer.
 - Wait ten seconds and then reattach the power cord.
- Remove the ink tanks.

2

Remove and
reinstall the
print head unit

- Open the compartment cover
 - Press in on the tabs on both sides of the compartment cover.
- Remove the print head unit.
- Reinstall the print head unit in the compartment.
- Close the compartment cover.
 - See page 4-16 for details

3

Turn the printer
back on

- Replace the ink tanks in the correct order.
- Press the **POWER** button to turn on the printer



Do not unplug the printer during the initialization. If you do, the printer will not be initialized correctly and may not print properly. Wait until the POWER light stops flashing and the printer goes on-line before performing any other print operations.

Clearing Paper Jams

When a paper jam occurs, the ERROR light comes on and the printer goes off-line. If you are using the Microsoft Windows Printing System, you see this Status Window:

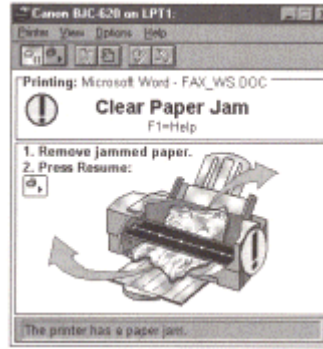

1

Gently pull the paper out with one hand while holding down the printer with the other hand

- Press ON LINE or click the Resume Printing button in the Status Window to continue printing.



If the paper tears off inside the printer, follow these steps

- Turn off the printer.
- Open the printer's cover.
- Remove the paper left inside the printer.
- Press the **POWER** button to turn the printer back on. The printer is now ready for printing.
- If the platen is soiled, wipe it clean with a dry cloth. See *Cleaning the Printer* on page 4-3 for details.

Ink Problems

Ink Tanks Continually Run Out of Ink

If your ink tanks seem to run out of ink before you think they should, make sure you are following these guidelines.

- Turn off the printer only when the print head unit is in the home position. When in the home position, the print head unit is capped; this protects the print head nozzles and ink cartridges from damage or drying out.
- Only transport the printer when the print head unit is in the home position
- Never unplug the printer or turn off a power strip to which the printer is attached when the printer's power is turned on.
- Try not to clean the print head unit unnecessarily. The print head cleaning procedure consumes a small amount of ink.
- Do not unplug the printer unnecessarily. The printer performs the print head cleaning operation, which uses a small amount of ink, every time you plug it in.
- Do not print documents with solid background colors. This consumes an excessive amount of ink.

Ink Tanks Incorrectly Installed

If you find that the ink tanks are installed in the wrong slots, follow these steps:

1

Remove each ink tank that is in an incorrect slot.

- Examine each tank to see if another color of ink has come into the tank and mixed with its ink.
- If this has happened, replace the ink tank with a new one.

2

Install the ink tanks in the correct slots.

- Execute the custom cleaning again for each of the colors that were installed incorrectly.
- You can repeat the custom cleaning procedure several times if the colors do not seem accurate.
- If the problem persists, replace the ink tanks with new ones.

Troubleshooting The Microsoft Windows Printing System

When a problem occurs, the Status Window displays the printer error message. To resolve the problem, press F1 to view the on-line help and then follow the instructions.

The following table contains additional information to help you solve any BJC-620 printer operation problems that may occur with the Microsoft Windows Printing System.

<u>Problem</u>	<u>Cause</u>	<u>Solution</u>
The Microsoft Windows Printing System does not work correctly	The Microsoft Windows Printing System for the BJC-620 may not be set as the default printer,	Set the Canon BJC-620 as the default printer as follows. When using Microsoft Windows 95: <ol style="list-style-type: none"> 1. Open the Printers folder and select the BJC-620. 2. On the File menu, click Set As Default.
		When using Microsoft Windows 3.1 or Microsoft Windows for Workgroups 3.1: <ol style="list-style-type: none"> 1. Double-click on the Printer Setup icon in the Microsoft Windows Printing System group. 2. Select the BJC-620. 3. Click on Set As Default Printer.
	The Microsoft Windows Printing System may not be properly installed,	Print the Microsoft Windows Printing System test page to make sure that the Microsoft Windows Printing System is installed correctly and the printer works correctly. To print the test page, press the Print Test Page button in the Status Window.
		Note: If the same port has been selected for the BJC-620 and another Microsoft Windows Printing System printer, connect the other Microsoft Windows Printing System printer to a different port (such as File). Then, restart Microsoft Windows.
Output looks too light	The print quality selection does not match your document.	If you select the High Speed (Text & Graphics) print quality, output tends to be light. Try High Quality Text or High Quality Graphics.
Output appears jagged	The resolution selected via the Microsoft Windows Printing System may be 180 x 180 dpi.	Changing the resolution to 360 x 360 dpi or higher should correct this problem.

<u>Problem</u>	<u>Cause</u>	<u>Solution</u>
Blurred or smudged ink	The printing option settings do not match your media.	Make sure you select a Media type appropriate for your media. If black ink is blurred on back print film or other kinds of paper when you select a high resolution (such as 720 x 720 dpi), select Photographic Quality as Print Quality in the Quality dialog box/tab. If black ink is still blurred, try to increase the brightness of black in the Graphics dialog box or Graphics & Color tab.
Color output looks rough	The Halftoning method selected via the Microsoft Windows Printing System may be Solid.	If you print graphics or scanned images, such as photographs, selecting Solid halftoning loses details on the output. If you print graphics, selecting Patterned is recommended. If you print scanned images, select Smooth halftoning. When you select 720 x 720 dpi, use Smooth halftoning for optimum print quality.
Prints only in black	Gray Scale Printing may be selected, which prints all documents in black and white.	Make sure Gray Scale Printing is not selected. If it is not selected, see your application's printing option settings. If there is a color printing option, make sure it is enabled.
Color output is not what you expect	The printing option settings do not match your document.	<p>The following printing option settings take effect on output:</p> <p>Media type—Be sure to select the media type that corresponds to your media.</p> <p>Resolution—Select a higher resolution for higher quality output and a lower resolution for lower quality output.</p> <p>Print Quality—Select High Speed (Text & Graphics) for draft printing, High Quality Text for text printing, and High Quality Graphics for graphics printing.</p> <p>Halftoning—Select Solid for text and simple graphics printing, Patterned for printing graphics that contain large solid color, or Smooth for printing scanned images.</p> <p>See the on-line help for details.</p>

<u>Problem</u>	<u>Cause</u>	<u>Solution</u>
High gloss film is soiled with black ink at a high resolution	Black ink on high gloss film does not dry easily,	When you print solid black areas at a high resolution (720 x 720 dpi)—such as in reversed characters—on high gloss film, black ink may adhere to the printed lines. If this happens, select Photographic Quality as Print Quality in the Quality dialog box/tab. If this does not solve the problem, try to increase the brightness of black in the Graphics dialog box or Graphics & Color tab.
Printing is slow	Printing options may be too complicated,	<p>Try to set all printing options to their default: 360 x 360 dpi, High Quality Text.</p> <p>These print options affect the printing speed as follows:</p> <p>Dots per Inch—Printing at a lower resolution (180 x 180 dpi) is faster and at a higher resolution (720 x 720 dpi) is slower.</p> <p>Print Quality—High Speed (Text & Graphics) is the fastest, and High Quality Graphics is the slowest.</p> <p>Try changing these settings.</p>
Paper does not feed correctly	You may not have selected the Paper Source that is suitable for your media type.	When you print High Gloss Film or heavier-weight print media, be sure to select Manual Feed as the paper source.

Technical Notes

If you have connected the BJC-620 to your computer and have turned it on, but your computer says it cannot find the printer, you may need to modify your BIOS setup.

This section describes the BIOS setups for several computer configurations. Our on-line services are updated with this type of information as it becomes available. If you are having a unique problem and do not see your computer here, be sure to use our on-line services (Web, BBS, CompuServe). See Getting Help From Canon in Chapter 1 (page 1-3) for details.

BIOS Setups for Various Systems

ACER View 11D

- Press CTRL ALT ESC
- Use Arrow Key to Go to Advanced
- Select Peripheral Configuration
- Cursor to Parallel Port Mode
- Press Enter
- Select ECP
- Press F10 to Save and Exit

AT&T Globalyst 363 TPC

- Hit F2 to Enter Setup
- Hit up Arrow Key to Go to Advanced
- Cursor Down to Integrated Peripherals
- Cursor Down to Parallel Port Mode
- Use Gray Plus Key to Select ECP
- Press Escape Twice
- Cursor Over to Exit
- Select Save Changes and Exit

Compaq 9234, 9222, 9221 BIOS

- Go to Device manager
- Click on the + Sign By Ports
- Double-click on the ECP Printer Port
- Select Resource Tab, and Make a Note of the Resources Settings
- Cancel Out of the LPT Port Properties
- Remove the ECP Printer Port From Device Manager
- Restart the Computer and Press the F10 Key (at 2 beeps or any other appropriate prompt)
- Press Enter, and Enter Again to Acknowledge Openings Messages
- Select Setup
- Select Communications
- Go to the LPT Port and Select the Resource Group that Matches the one Noted in Device Manager (setup 4) ***but without the dma***
- Exit and Save, the System will reboot, and should detect and configure a "NON ECP" Printer Port including the Printer

COMPAQ Presario CDS 972

- While Rebooting, Hit F10 to Enter Setup
- Click on Communications Section
- Click on LPT PORT MODE
- Select Bi-directional
- Click (or Hit) Exit
- When it asks you if you want to save, Hit "Y" for Yes

Dell Dimension P100

- Press Delete to Enter Setup
- Press Delete to Enter Setup
- Press ALT P
- Cursor to Parallel Mode
- Change to PS/2 or ECP by Using Arrow Keys
- Pressing Escape will Exit and Save Changes

Digital 930 BIOS Instructions

- Press F2 to Enter Setup
- Use up Arrow Key to Go to Top Toolbar
- Use Right Arrow Key to Go to Advanced
- Hit Enter on Advanced
- 3rd Item is Parallel Port Mode
- Use Plus Key to Change From Compatible to Bi-directional
- Hit Escape to Go to Main Menu
- Select Save Changes and Exit
- Notice Changes and Have Been Saved (continue)

Gateway 2000 P575

- Reboot Press F 1
- Select Advanced Setup
- Select Peripheral Configuration
- Cursor to Parallel Port Mode
- Press Enter
- Select "ECP"
- Press F10 to Save and Exit

Gateway Pentium 90 BIOS Setup

- Press F1 to Enter Setup
- Cursor Over to Peripheral Configuration
- Hit Enter
- Cursor Down to Parallel Port Mode and Hit Enter
- Select ECP-EPP Mode
- Hit Enter
- Press Escape
- Press F10 to Save and Exit
- Select "Save Settings and Exit"
- Hit Enter

GENISYS Pentium S BIOS

- After Rebooting, Press DEL to Enter Setup
- Cursor Down to Chipset Features and Hit Enter
- Cursor Down to Onboard Parallel Mode
- Use PageUp key to Select ECP Mode
- Press Escape
- Press F10 to Save Settings and Exit
- Press "Y" for Yes
- Hit Enter

IBM Aptiva

- F1 to Enter Setup
- Advanced Options
- Select Input/Output Options
- Press Enter
- Highlight Parallel Printer Options
- Select Using the Right and Left Arrow Keys

IBM Thinkpad BIOS Instructions

- Hold F1 Down While Turning on Computer
- Cursor Over to Config Icon
- Press Enter
- Cursor Over to Parallel
- Hit Enter
- Cursor Over to Bi-directional and Hit Enter
- Go to Bottom and Hit OK
- Go to Bottom and Hit OK
- Cursor Over to Restart and Hit OK

MICRON T133 w/Phoenix BIOS

- Press F2 to Enter BIOS
- Cursor to Advanced System Setup and Hit Enter
- Cursor to Integrated Peripherals and Hit Enter
- Cursor to LPT MODE: (AT)
- Use Gray Plus Key to Select ECP
- Hit Escape Twice
- Cursor to Exit and Hit Enter
- Answer "Yes" to Save Settings

Packard Bell 411 & 102 CP

- Press F1 to enter Setup.
- Hit Right Arrow Key until you get to Advanced.
- Cursor to Peripheral Configuration
- Hit Enter
- Cursor Down to Parallel Port Mode (will say Bi-directional)
- Hit Enter
- Cursor Down to ECP and Hit Enter
- Press Escape
- Hit F10 to Save and Exit
- Hit Enter

Packard Bell 823 CDTW

- Press F1 to Enter Setup
- Arrow to Integrated Peripherals
- Change PARALLEL PORT MODE to AUTO
- Press Escape Twice
- Save and Exit

Packard Bell Excel 2005 Plus

- Press CTRL ALT S to Enter Setup
- Select ADVANCED SYSTEM Setup
- Hardware Configuration
- Change Parallel Port Mode to "OUTPUT ONLY"

Packard Bell Excel 461

- Press F2 to Enter Setup
- Select Submenu
- Select Integrated Peripherals
- Press Enter
- Tab to LPT MODE will say "Bi-directional" press +/- to change value to "OUTPUT ONLY"
- Press Escape Twice
- Save Changes and Exit

Packard Bell Legend 812 CP

- Press F2 to Enter Setup
- Hit Right Arrow Key to Go to Advanced
- Hit Enter
- Screen Shows Integrated Peripherals, Hit Enter
- Cursor Down to LPT Mode: Output Only
- Hit Plus Key to Go to ECP Mode
- Hit Escape
- Hit Escape
- Select Save Changes and Exit
- Hit Enter

Packard Bell Legend 822 CD

- Press F1 to Enter Setup
- Hit Right Arrow Key to Go to Advanced
- Hit Enter
- Screen Shows Integrated Peripherals, Hit Enter
- Cursor Down to LPT Mode: Compatible
- Hit Enter
- Hit Arrow Key to Go to ECP Mode
- Hit Enter
- Hit Escape Hit F10
- Select Save Changes and Exit
- Hit Enter

Specific



Printing Method

Bubble jet ink on-demand

Paper Handling

Automatic feed

Manual feed

Sheet Feeder Capacity

Maximum thickness of stacked paper:	0.35 in (9 mm)
Plain paper	Approximately 100 sheets
Bubble Jet paper	Approximately 100 sheets
Coated paper	Approximately 80 sheets
High resolution paper	Approximately 80 sheets
Transparencies	50 sheets
Back print film	50 sheets
High gloss film	1 sheet
Fabric sheets	1 sheet
T-shirt Transfers	1 sheet
Greeting cards	1 sheet
Brochure paper	1 sheet
Thick paper	1 sheet
Envelopes	15 envelopes (U.S. Commercial number Envelopes 10 o

Paper Size

Letter	8.5 in x 11 in
Legal	8.5 in x 14 in
A4	210mm x 297mm
B5	182mm x 257mm
U.S. Commercial number 10 envelope	9.5 in x 4.1 in
European DL envelope	220 mm x 110 mm

Recommended Paper Types

Coated paper

High resolution paper

Transparencies (OHP film)

Back print film

High gloss film

T-shirt transfers

Fabric sheets

Greeting cards

Brochure paper

Envelopes

Canon Coated Paper LC-101

Canon High Resolution Paper HR-101

Canon Transparencies CF-102

Canon Back Print Film BF-102

Canon High Gloss Film HG-101

Canon T-Shirt Transfers TR-101

Fabric Sheet FS-101

Canon Greeting Cards GC-101

Canon Brochure Paper BP-101

U.S. Commercial number 10 or Europea

Paper Weight

17 to 24 lb (64 to 90 g/m²) with automatic feed

17 to 28 lb (64 to 105 g/m²) with manual feed

Paper Thickness

Less than 0.008 in (0.2 mm)

Print Speed

High Speed (Text & Graphics) mode

High Quality Text mode

High Speed (Text & Graphics) mode

300 cps at 10 cpi

205 cps at 10 cpi

Approximately 0.7 to 1.3 ppm

(8 x 10 inch full coverage of printable ar

Print Width

Maximum

8 inches (203.2 mm)

Line Feed Speed

Approximately 100 ms per line at 1/6-in line

Printing Direction

Bi-directional

A-2 Specifications

Appendix A

Printable Area—Papers

The shaded portion in the following figure shows the printable area for papers.

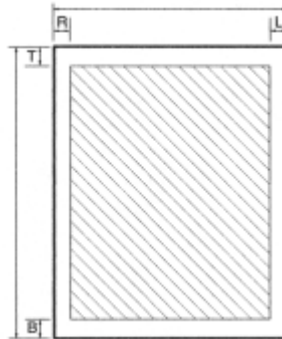

Margins	Inches	mm
Right	0.25 in	3.4 mm
Left	0.25 in	3.4 mm
Top	0.33 in	8.5 mm
Bottom	0.28 in	7.11 mm

Printable Area—Envelopes

The shaded portion in the following figure shows the printable area for envelopes.

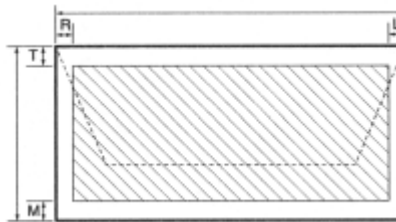

Margins	Inches	mm
Right	0.25 in	6.4 mm
Left	1.24 in	10.4 mm
Top	0.12 in	3.0mm
Bottom	0.28 in	7.11 mm

Print Head Unit

Type: 64 nozzles for each color

Ink Tanks

Black

Type: BJI-201 Bk HG

Ink color: Black

Number of characters printed: Approx. 450 pages in High Quality Text mode (5% coverage)
Approx. 800 pages in High Speed (Text & Graphics) mode (5% coverage)

Color

Type: BJI-201 C, M, Y

Ink color: Cyan (C), Magenta (M), Yellow (Y)

Number of characters printed: Approx. 210 pages in High Quality Text mode (7.5% coverage for each color)
Approx. 300 pages in High Speed (Text & Graphics) mode (7.5% coverage for each color)

Interface
8-bit parallel

To receive information regarding the interface, call Canon's toll-free Fax Retrieval System 4345 and request the BJC-620 Interface Sp

Acoustic Noise Level Per ISO 9296
Under 45 dB(A) in High Quality and High Speed modes

Operating Environment

Temperature
Humidity

41° F to 95° F (5° C to 35° C)
10% to 90% RH (no condensation)

Storing Environment

Temperature
Humidity

32° F to 95° F (0° C to 35° C)
5% to 95% RH (no condensation)

Power Source

USA/Canada

AC 120 V, 60 Hz, 0.5A
Canon recommends that the printer be used on a dedicated power source only.

Power Consumption

11 watts standby
29 watts maximum printing

Dimensions

16.1 in (410 mm) W x 9.96 in (253 mm) D x 7.2 in (184 mm) H

Weight

Approx. 9.9 lb (4.5 kg)

Operator Panel

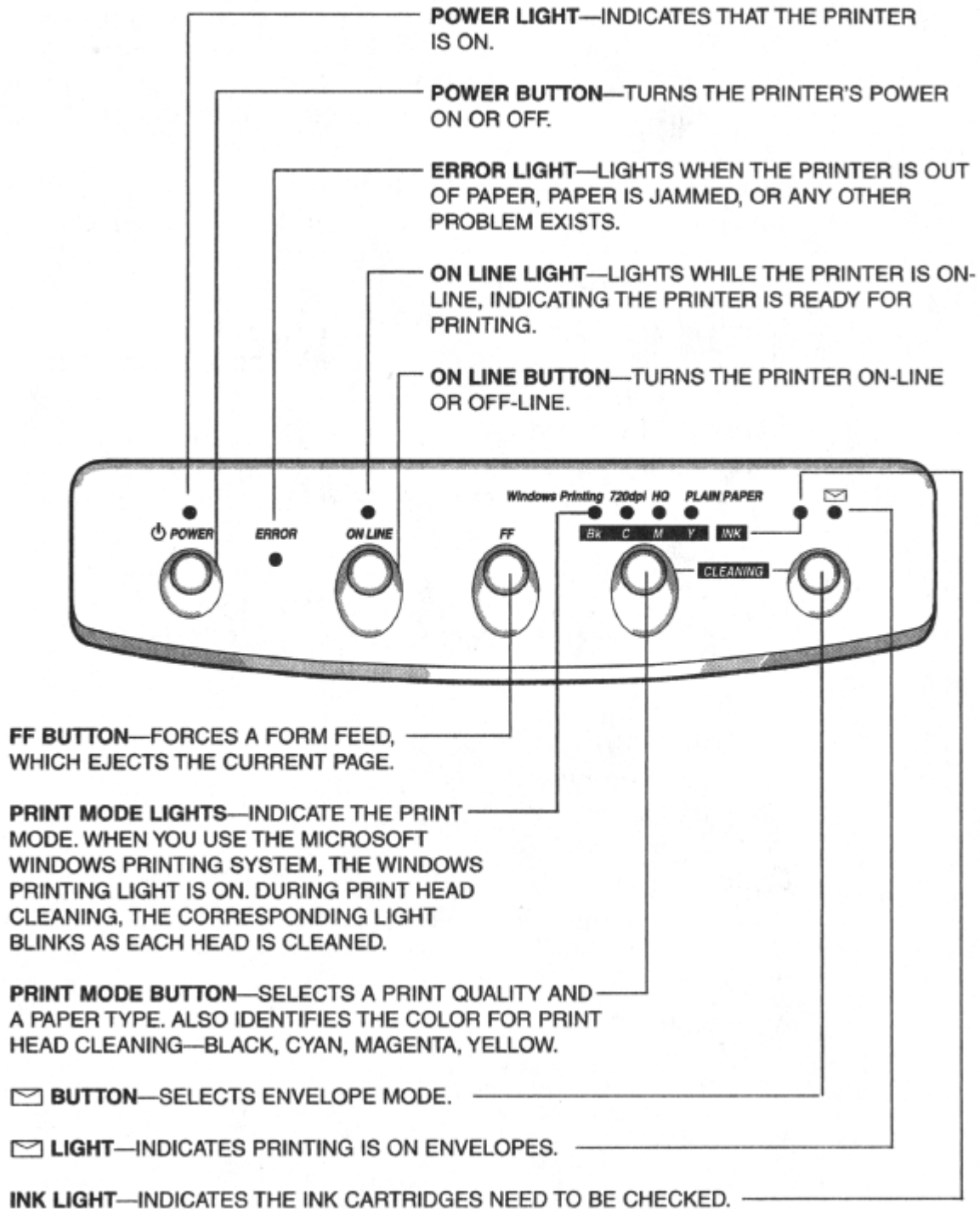

Using the BJC-620 in a Network Environment



You can use the BJC-620 that is connected locally to your computer or your network.

Sharing a Printer

You can share the BJC-620 in a Microsoft Windows 95 or Microsoft Workgroups 3.1 environment as described in this appendix.

Microsoft Windows 95

1. In the Printers folder, select the BJC-620 you want to share.
2. Choose Properties from the File menu.
3. Open the Sharing tab and select Share As. Enter a share name in the appropriate box, and then click **OK**.

For details, see the Microsoft Windows 95 documentation and consult your network administrator for specific information about your network.

Microsoft Windows For Workgroups 3.1

1. In the Printers folder, select the BJC-620 you want to share.
2. On the toolbar, click the  button, or choose Share Printer As from the menu.
3. In the Share Printer dialog box, enter a share name and click **OK**.

For details, see the Microsoft Windows for Workgroups 3.1 documentation and consult your network administrator for specific information about your network.

Connecting to a Network Printer

When you install the Microsoft Windows Printing System without connecting to a printer, the program asks whether you want to redirect the selected port to a network printer or not. After you select a port, you see this screen:

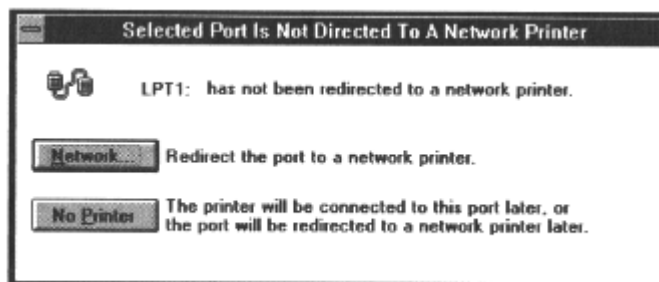

1

Select Network

- If you want to connect your computer to a network printer that is being shared, the Network Printer Resources dialog box appears.

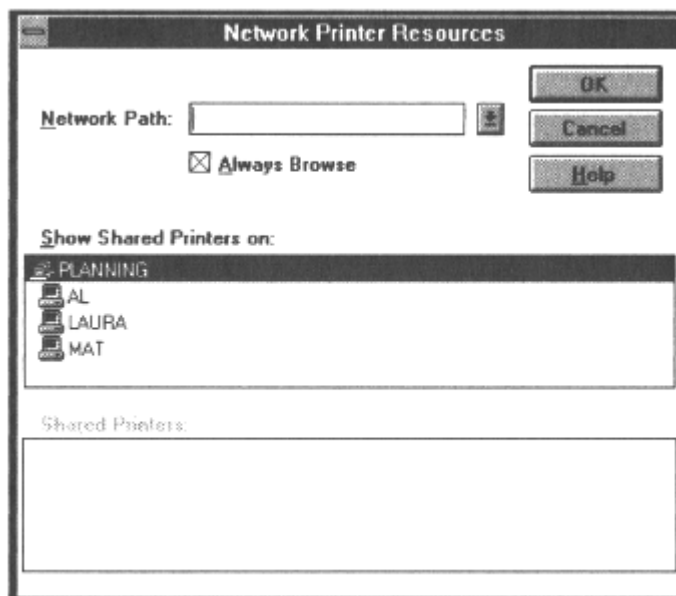

2

Specify Network Printer

- Select the network printer by selecting the network printer's path.

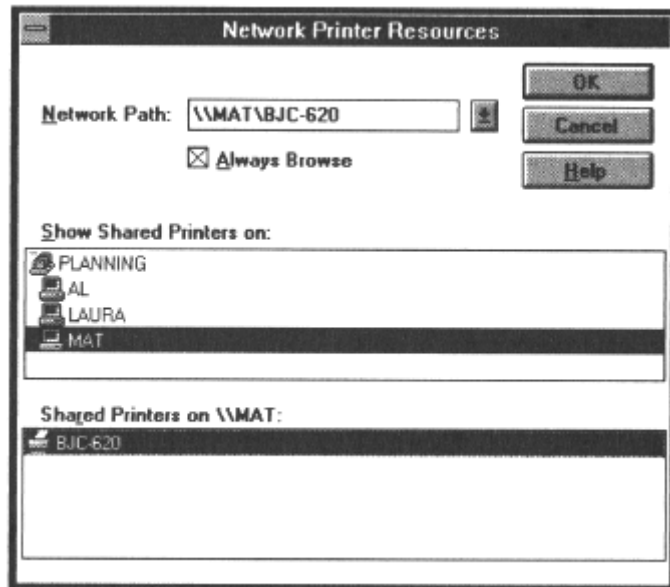

3

Choose OK.

- The network printer is connected to the selected port.
- Choose OK to continue installation.

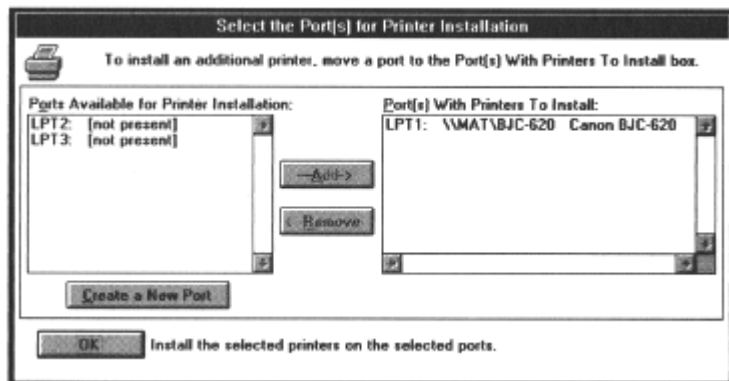

You can connect to a network printer after installing the Microsoft Windows

For details, see the Microsoft Windows 95 or Microsoft Windows for Workgroup documentation

Free Manuals Download Website

<http://myh66.com>

<http://usermanuals.us>

<http://www.somanuals.com>

<http://www.4manuals.cc>

<http://www.manual-lib.com>

<http://www.404manual.com>

<http://www.luxmanual.com>

<http://aubethermostatmanual.com>

Golf course search by state

<http://golfingnear.com>

Email search by domain

<http://emailbydomain.com>

Auto manuals search

<http://auto.somanuals.com>

TV manuals search

<http://tv.somanuals.com>