

Canon

VISUAL COMMUNICATION SYSTEMS

Video Visualizer **RE-350**



Control Interface Commands

v1.0

Control Interface Command Index

1.0 Operations and Functions

1.1 Panel Diagrams	3
1.2 Description of the Panel Functions	4-8
1.3 Operational Procedures Overview	9-13
1.4 The Default Setting of Each Function	14
1.5 Meaning of Each LED Status	14
1.6 Control Protocol	15
1.7 Packet Discrimination Code Assignment	15
1.8 Data Packet Configuration	16
"Control Command Packet" Format	16
"C-response Data Packet" Format	16
"Event Data Packet" Format	16
"E-response Data Packet" Format	16
"FP Data Packet" Format	16
1.9 Operational Flow Charts	17-18
Command Communication Flow Pattern	17
Event Packet Flow Pattern	17
[NOTIFICATION] Mode Flow Pattern	18

2.0 Control Command and Packet Tables

2.1 Camera Control Commands Table	19
2.2 System Control Commands Table	20
2.3 "C-response Data Packet" Table	21
2.4 "Event Data Packet" Table	22
2.5 "E-response Data Packet" Table	23
2.6 "FP Data Packet" Table	24

3.0 Description of Command Data Packet

3.1 Zoom	25-29
3.2 Focus	30-32
3.3 White Balance	33
3.4 Exposure	34
3.5 Detail	35
3.6 Negative/Positive	36
3.7 Color/B&W	37

4.0 System Control Commands

4.1 Detailed System Control Commands	38-54
--	-------

5.0 Control Cable Pin Assignments

5.1 RS-232C Control Cable Pin Assignments	55-57
---	-------

6.0 Timing Charts

6.1 RTS/CTS Flow Control Timing Chart	58
6.2 RTS Flow Control Timing Chart	59

Appendix A - Disk Information	60-63
-------------------------------------	-------

1.0 Operations and Functions

1.1 Panel Diagrams

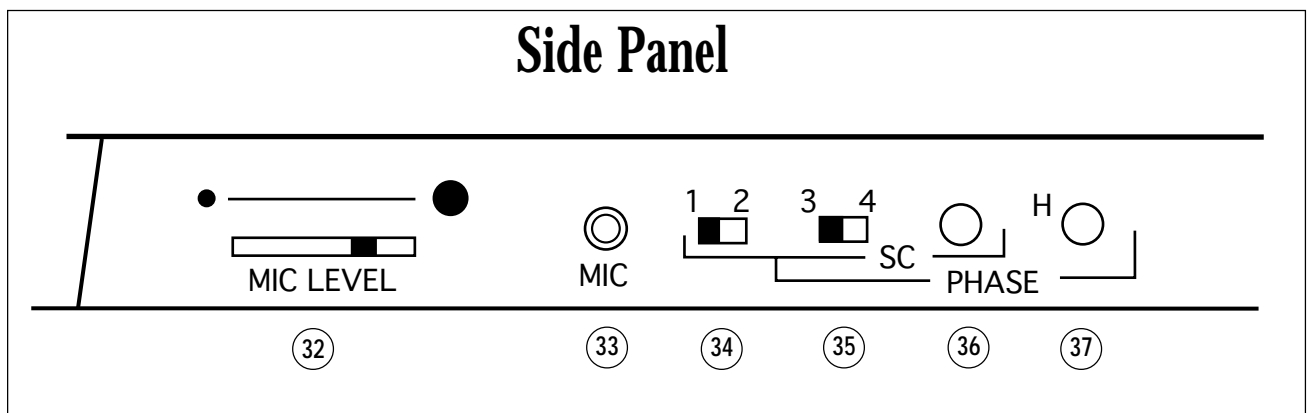
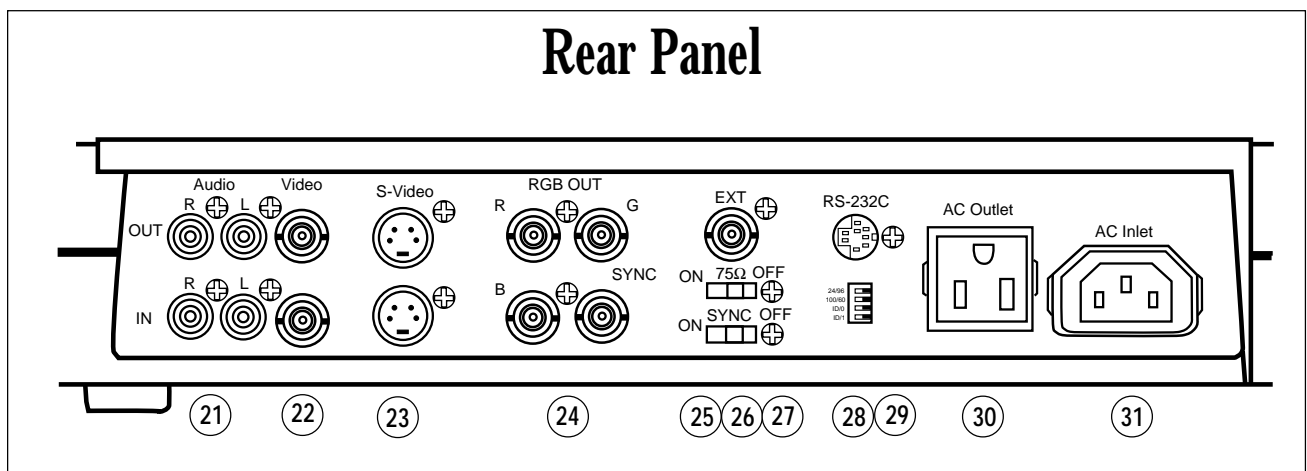
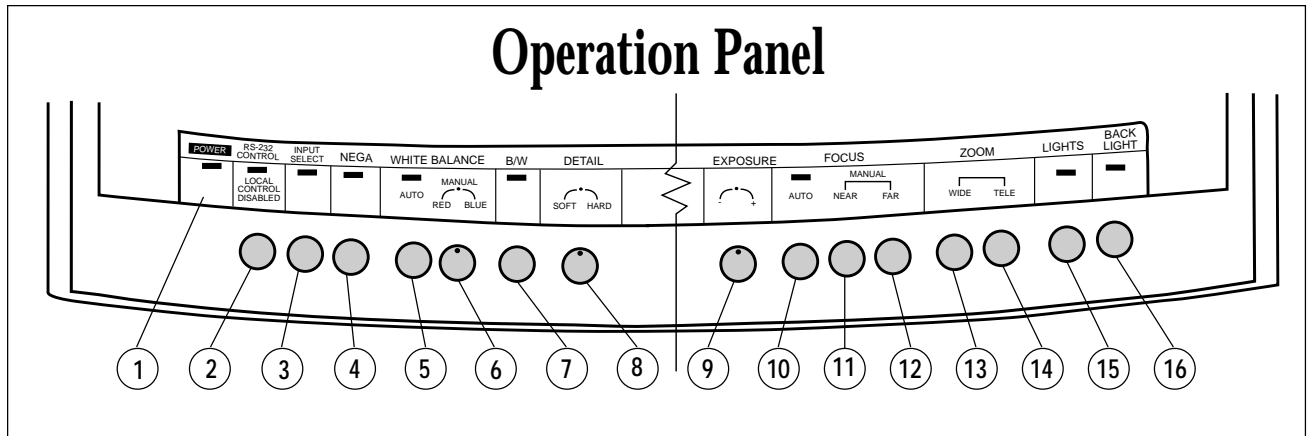

1.2 Description of the Front and Rear Panel Functions

Button/ Control Knob	Key	Function
RS-232 CONTROL † (Button)	②	<p>Switches the mode from [ON-LINE] Mode to [OFF-LINE] Mode or from [OFF-LINE] Mode to [ON-LINE] Mode.</p> <p>In the [OFF-LINE] Mode the RE-350 will send the “Event Data Packet” for ‘Request on line’. In the [ON-LINE] Mode or [NOTIFICATION] Mode the RE-350 will send the “Event Data Packet” for ‘Request off line’.</p> <p>[OFF-LINE] Mode The RE-350 will reject the RS-232 commands from the PC except for the [ON-LINE] Mode command or the [NOTIFICATION] Mode command. The RE-350 should be set to [OFF-LINE] Mode when it is to be controlled from the front panel. The RS-232 LED will be off.</p> <p>[ON-LINE] Mode The RE-350 will reject every input from the front panel except from the {RS-232 Control}† button and will accept only RS-232 command data packets from the PC. The RS-232 LED will be on.</p> <p>[NOTIFICATION] Mode (Used in [ON-LINE] Mode only.) The RE-350 reports the condition of each button/control knob pressed to the PC using the “Event Data Packet”. Each RE-350 function will be controlled by the “Command Data Packet” from the PC. The only function which can respond is manual operation of the {RS-232} button.</p>
INPUT SELECT (Button)	③	<p>Selects the input video signal or document camera signal to send to the video output terminal (Composite Video and S-video).</p>
NEGA (Button)	④	<p>Negative/Positive conversion toggle button. Toggles the video output between positive and negative.</p>
WHITE BAL. AUTO (Button)	⑤	<p>Press to set the white balance automatically. This tries, for 6 seconds, to find a proper white balance position, if the proper position is not found, the White Balance Auto LED will be turned off to show that no proper white balance position was found. <u>Note:</u> The RE-350 will Auto White Balance once at start-up.</p>
WHITE BAL. MANUAL (Control Knob)	⑥	<p>Adjusts the color balance. The resulting auto white balance position will be used as the center value for this control knob. The color will shift to blue when this control knob is turned right, and to red when turned left. This control knob will operate under Positive and Negative mode. This control knob does not work while the RE-350 is auto focusing.</p> <p>† The {RS-232 Control} button will be referred to as the {RS-232} button.</p>

Button/ Control Knob	Key	Function
B/W (Button)	7	Toggles the video output between color and black & white.
Detail (Control Knob)	8	Adjusts the sharpness of the output video image. Turning to the right sharpens the image and turning to the left softens the image.
EXP (Control Knob)	9	Adjusts the exposure control. The RE-350 has an auto-IRIS function. If any adjustment is necessary, the exposure can be changed. Turning it to the right makes the image brighter and turning it to the left makes it darker.
FOCUS AUTO (Button)	10	One Time Focus Adjustment When this button is pushed, the RE-350 starts to find the best focal point. Once the best focal point is successfully found, the RE-350 will stop the focus lens at that point. If the RE-350 cannot find the best focal point in 6 seconds, the RE-350 will stop the search operation and turn off the Focus LED.
FOCUS NEAR (Button)	11	While this button is being pushed, the RE-350 moves the focus lens towards the <i>NEAR</i> focus point. If the button is released or the focus lens arrives at it's maximum focal point, the RE-350 will stop its focus lens adjustment.
FOCUS FAR (Button)	12	While this button is being pushed, the RE-350 moves the focus lens towards the <i>FAR</i> focus point. If the button is released or the focus lens arrives at it's maximum point, the RE-350 will stop its focus lens adjustment.
ZOOM WIDE (Button)	13	While this button is being pushed, the RE-350 moves the zoom lens in the <i>WIDE</i> zoom direction. If the button is released or the zoom lens arrives at the maximum point, the RE-350 stops it's zoom lens movement. If this button continues to be pressed for longer than one second, the speed of the zoom lens is accelerated.
ZOOM TELE (Button)	14	While this button is being pushed, the RE-350 moves the zoom lens in the <i>TELE</i> zoom direction. If the button is released or the zoom lens arrives at the maximum point, the RE-350 stops it's zoom lens movement. If this button continues to be pressed for longer than one second, the speed of the zoom lens is accelerated.
LIGHTS (Button)	15	Preheats, then turns on the document lights. The white balance will be adjusted once. If the backlight is on, it will be automatically turned off when the document light button is pressed.
BACKLIGHT (Button)	16	Turns on the backlight. The white balance will be adjusted once. If the document lights are on, they will be automatically turned off when the backlight button is pressed.

Button/ Control Knob	Key	Function
Audio In/Out	21	External audio input (10 k Ω) RCA terminal 3 dB ~ -12 dB Audio output (1k Ω)
C-Video In/Out	22	Composite video input (BNC terminal 75 Ω) Composite video output (BNC terminal 75 Ω)
S-Video In/Out	23	S-video in (S-DIN connector 75 Ω) S-video out (S-DIN connector 75 Ω)
RGB OUT	24	RGB signal (BNC terminal 75 Ω): B/W mode is not available when using RGB out. G-signal will have a sync when the {Sync on/off} switch is on.
Sync On/Off	25	While {Sync on/off} switch is off, this BNC terminal will have a synchronization signal 4.0 V \pm 0.8 Vp-p.
75Ω On/Off	26	External Synchronization signal impedance sets.
Ext	27	A referencing video signal input terminal for genlock function. (BNC terminal)
RS232C I/F	28	RS232C serial communication terminal (2400 bps or 9600 bps) to receive control commands from a PC or other control box.
Digital Switches	29	(See page 7 for full explanation.)
AC Output	30	120 V AC output with 3 pin (2 signal and Ground) terminal.
AC Input	31	120 V AC input terminal.

Button/ Control Knob	Key	Function																											
Digital Switches	29	<p>Sets the electronic shutter speed, RS232C communication bit rate and ID number of the RE-350.</p> <p>[RS232C communication speed]</p> <table border="1" data-bbox="555 401 1252 556"> <thead> <tr> <th>Switch 1</th> <th>Communication Speed</th> </tr> </thead> <tbody> <tr> <td>0</td> <td>9600 bps</td> </tr> <tr> <td>1</td> <td>2400 bps</td> </tr> </tbody> </table> <p>[Electronic shutter speed]</p> <table border="1" data-bbox="555 630 1252 785"> <thead> <tr> <th>Switch 2</th> <th>Shutter Speed</th> </tr> </thead> <tbody> <tr> <td>0</td> <td>1/60 sec</td> </tr> <tr> <td>1</td> <td>1/100 sec</td> </tr> </tbody> </table> <p>[Identification number (ID)]</p> <table border="1" data-bbox="555 840 1252 1119"> <thead> <tr> <th>Switch 3</th> <th>Switch 4</th> <th>ID Number</th> </tr> </thead> <tbody> <tr> <td>0</td> <td>0</td> <td>0</td> </tr> <tr> <td>1</td> <td>0</td> <td>1</td> </tr> <tr> <td>0</td> <td>1</td> <td>2</td> </tr> <tr> <td>1</td> <td>1</td> <td>3</td> </tr> </tbody> </table> <p>Note: The electronic shutter speed will be updated as soon as the digital switch is set. The communication speed switch and ID number switch will be updated only when the main power is turned on. The 1/100 sec electronic shutter can reduce the flicker effect caused by a 50 hz power supply.</p>	Switch 1	Communication Speed	0	9600 bps	1	2400 bps	Switch 2	Shutter Speed	0	1/60 sec	1	1/100 sec	Switch 3	Switch 4	ID Number	0	0	0	1	0	1	0	1	2	1	1	3
Switch 1	Communication Speed																												
0	9600 bps																												
1	2400 bps																												
Switch 2	Shutter Speed																												
0	1/60 sec																												
1	1/100 sec																												
Switch 3	Switch 4	ID Number																											
0	0	0																											
1	0	1																											
0	1	2																											
1	1	3																											

Button/ Control Knob	Key	Function
Audio Volume (slider)	32	Controls the audio output level.
Audio Input	33	450 ~1200 Ω (Level: -20db ~ -68 dB at 1Khz signal)
SCp90° (switch)	34	1 : 0 degree shift 2: 90 degree shift
SCp180° (switch)	35	3: 0 degree shift 4: 180 degree shift
SCp (Control Knob)	36	Sub-carrier phase will be adjustable 0 ~ 90 degree by this knob.
Hp (Control Knob)	38	Adjust the Horizontal video output phase (0 ~ 2 μ sec) on the base of the external signal.

1.3 Operational Procedures Overview

1.3.1 Procedure for using the Front Panel

Order	Operations	RE-350's Condition and LED Status
1	With the shutter speed switch, set the proper shutter of the RE-350.	
2	Turn on the main power.	<ol style="list-style-type: none">1. The power LED on the RE-350 will be turned on2. Automatically the RE-350 will be initialized.3. The White Balance will be adjusted automatically and the White balance LED will blink while finding a proper white balanced setting. If the RE-350 can not find a proper setting, the White Balance LED will be off, if setting is found, the LED will be on.4. The RE-350 will start to find the point of focus, the Auto Focus LED will be blinking. Once the appropriate point of focus is found, the Auto Focus LED will be on, if not, the LED will be off.
3	Operate designated switches.	The RE-350 will operate according to the condition of the switches.
4	Turn off the main power.	The RE-350 will be turned off and every LED will be off.

1.3.2 Procedure for Using the RS-232C Serial Interface

Order	Operations	RE-350's Condition and LED Status
1	With the shutter speed switch, set the shutter of the RE-350.	
2	Set an ID number for this RE-350 using the DIP switches on the rear panel.	
3	Set communication speed for RS-232C I/F with the DIP switches on the rear panel.	
4	Properly connect the RE-350 to the PC with an approved serial cable.	
5	Turn on the PC. (This operation may be done after the RE-350 is turned on.)	
6	Turn on the main power of the RE-350.	<ol style="list-style-type: none"> 1. The power LED on the RE-350 will be turned on 2. Automatically the RE-350 will be initialized. 3. The White Balance will be adjusted automatically and the White Balance LED will blink while finding a proper white balanced setting. If the RE-350 can not find a proper setting, the White Balance LED will be off, if setting is found, the LED will be on. 4. The RE-350 will start to find the point of focus, the Auto Focus LED will be blinking. Once the appropriate point of focus is found, the Auto Focus LED will be on, if not, the LED will be off.
7	Set the RE-350 to [ON-LINE] Mode. In order to put the RE-350 in [ON-LINE] Mode, the following two methods will be available:	<ol style="list-style-type: none"> 1. The RE-350 will send Request On Line event data to the PC, the RS-232 LED will blink. 2. After the reception of <Accepted> E-response data, the RE-350's status shifts to [ON-LINE] Mode and the RS-232 LED will turn on. If the RE-350 receives <Denied> E-response data, the RE-350 remains in [OFF-LINE] Mode and turns the RS-232 LED off. (Refer to Section 2.5)
	<ol style="list-style-type: none"> 1. Push the {RS-232} button on the front panel. 	
	<ol style="list-style-type: none"> 2. The PC sends an [ON-LINE] or [NOTIFICATION] command. 	

Order	Operations	RE-350's Condition and LED Status
8	Send designated commands to the RE-350 for control.	The RE-350 will operate according to the given commands. (Refer to Section 2.0)
9	<p>Set the RE-350 to [OFF-LINE] Mode. In order to put the RE-350 in [OFF-LINE] Mode, the following two methods will be available:</p> <hr/> <p>1. Push the {RS-232} button on the front panel.</p> <hr/> <p>2. The PC sends the [OFF-LINE] command to the RE-350.</p>	<p>1. The RE-350 will send Request Off Line event data to the PC and the RS-232 LED will blink.</p> <p>2. After the reception of <Accepted> E-response data, the RE-350's status shifts to [OFF-LINE] mode and the RS-232 LED will turn off. If the RE-350 receives <Denied> E-response data, the RE-350 stays in [ON-LINE] Mode and the RS-232 LED remains on.</p> <p>If the PC does not respond in one second with E-response data, the RE-350 will repeat Request Off Line event data up to twice and if still no E-response data, the RE-350 stays in [ON-LINE] Mode and maintains RS-232 LED on. (Refer to Section 2.5)</p> <hr/> <p>The RE-350 responds with C-response data and it shifts to [OFF-LINE] Mode and the RS-232 LED turns off.</p>
10	Turn off the main power on the RE-350.	The main power of the RE-350 will be off and every LED will be off.

1.3.3 Procedure for Using the Control Knobs

Mode	Meaning
[OFF-LINE] Mode	<p>Adjusting the value of each control knob. The physical position of each control knob on the front panel is used to measure and adjust it's respective value.</p>
	<p>Setting the center target value for Auto-White Balance. The physical position of the white balance control knob will be used as the center value to measure and adjust the white balance.</p>
[ON-LINE] Mode	<p>Adjusting the value of each control knob. The physical position of each control knob on the front panel will be disregarded and the value of the “command data packet” from the PC will be used to measure and adjust the control knob's respective value.</p>
	<p>Setting the center target value for Auto-White Balance. The control knob's physical position will be saved into the Auto-White Balance position buffer when the RE-350 shifts to [ON-LINE] Mode. If the PC gives the proper command data to set the Auto-White Balance control knob's position, the buffer data will be updated.</p>
[NOTIFICATION] Mode	<p>Adjusting the value of each control knob.. The physical position of each control knob on the front panel will be disregarded and the value of the “command data packet” from the PC will be used to adjust the control's respective value.</p>
	<p>Setting the center target value for Auto-White Balance The control knob's physical position will be saved into the Auto-White Balance position buffer when the RE-350 shifts to [ON-LINE] Mode. If the PC gives the proper command data to set the Auto-White Balance control knob's position into the buffer, the given data will be updated.</p>
<p>Note: When the mode of the RE-350 shifts from [ON-LINE] Mode or [NOTIFICATION] Mode to [OFF-LINE] Mode, the center target value for Auto-White Balance will be changed from the value in the Auto-White Balance control knob position buffer to the physical position of the Auto-White Balance control knob automatically. The manual white balance data given from the PC will be disregarded.</p>	

1.3.4 Procedure for Using the {RS-232} Button

Function of {RS-232} button

By pressing this button, toggles the RE-350's RS232C I/F from active to inactive for communication with the PC or another controller device.

Once the RE-350 detects that the {RS-232} button was pressed, the RE-350 will send an Event data packet to the PC through the RS232C I/F to tell the PC that the operator is trying to change the mode.

The Event data packet will differ according to the RE-350's current mode.

Current Mode	The Kind of Event-data-packet
OFF	LineRequest ON Line
ON	LineRequest OFF Line
Notification	Request OFF Line

Note:

1. The RE-350 will shift its mode after the RE-350 receives an <Accepted> E-response data from the PC.
The RE-350 can not shift its mode to [NOTIFICATION] Mode directly. In order to set RE-350 to [NOTIFICATION] Mode, the PC has to give the <Notification> command to the RE-350 while in [ON LINE] Mode.
2. After the {RS-232} button is pressed and before the mode of the RE-350 is determined, the RE-350 will be in a mode transition. To tell this transition status to the operator, the RE-350's RS-232 LED will blink. While the RE-350 is in this transition, every button, control knob or command from the PC, will be disregarded.

1.4 The Default Setting of Each Function After Power-On

Function	Default Setting
Communication mode	[OFF-LINE] Mode
Input signal selection	Document Camera
Nega/Posi	Positive
White Balance	Locked at the proper white balance
Color / B&W	Color
Focus	Stopped at the maximum focus point
Zoom	Stopped
Document lights	Off
Back light	Off
Electronic shutter speed	Depends upon the setting of the digital switches
Communication speed	Depends upon the setting of the digital switches
ID number	Depends upon the setting of the digital switches

1.5 The Meaning of Each LED Status

LED	Status	Meaning
RS-232	on	Communication mode is [ON-LINE] or [NOTIFICATION] Mode.
	off	Communication mode is [OFF-LINE] Mode.
	blink	Communication mode is transferring. 3 Hz
INPUT SELECT	on	External Video signal is selected.
	off	Document camera signal is selected.
	blink	N.A.
NEGA	on	Negative video signal is output.
	off	Normal video signal is output.
	blink	N.A.
WHITE BALANCE AUTO	on	The auto-white balance was adjusted successfully.
	off	The auto-white balance could not be adjusted.
	blink	Auto-white balance is being adjusted. 3 Hz
B/W	on	Output video signal is black and white.
	off	Output video signal is color.
	blink	N.A.
FOCUS AUTO	on	Auto focusing was done successfully.
	off	Auto focusing failed or is in manual focusing mode.
	blink	Auto focus is being adjusted. 3 Hz
LIGHTS	on	Document Lights are on.
	off	Document Lights are off.
	blink	Document lights are being preheated. 3 Hz
BACKLIGHT	on	Backlight is on.
	off	Backlight is off.
	blink	N.A.

1.6 Control Protocol

RS-232C Interface Connection

Transmission Mode	Full Duplex
Transfer Speed	9600 bps or 2400 bps
Start Bit	1 bit
Data Bit	8 bit
Parity	0 bit
Stop Bit	2 bit
Handshake	RTS/CTS flow control
Others	One response per Command

Note: RS-232C hand shake control signals originate from the PC side (DTE) in this document. In this document, hexadecimal data will be defined with “\$” in front of a number or “h” in back of a number.

1.7 Packet Discrimination Code Assignment

Hexadecimal	Function
10h	“Command Data Packet”
A0h	“C-response Data Packet”
20h	“Event Data Packet”
B0h	“E-response Data Packet”
30Fh	“FP Data Packet”

Every data packet consists of 5 bytes of data.

If the RE-350 receives another kind of data packet which will be described below, the RE-350 will disregard the data packet and while the RE-350 recognizes the data packet is incorrect, the RE-350 will inactivate the CTS signal line to the PC.

ID number

Each RE-350 can have an individual ID number, (0,1,2 or 3), which will be set by digital switches 3 and 4 on the rear panel. The RE-350 will neglect the command data packet which has a different ID number. The PC can recognize which RE-350 responds.

Parameter

Each data packet has this parameter. If the data packet does not need the parameter, the content should be set by \$0000.

1.8 Data Packet Configuration

Control Command Packet Format (PC → RE-350)

The PC can request an operation from the RE-350 using this command.

Header	ID number	Command number	Parameter	
10h	* *h	* *h	MSH	LSH

C-Response Data Packet Format (PC ← RE-350)

The PC can determine whether the RE-350 could perform and finish an operation command given to it by the PC or failed to perform the operation command given to it by the PC.

Header	ID number	Response number	Parameter	
A0h	* *h	* *h	MSH	LSH

Event Data Packet Format (PC ← RE-350)

When the RE-350's {RS-232} button is pushed, the RE-350 will send this packet to the PC.

Header	ID number	Event number	Parameter	
20h	* *h	* *h	MSH	LSH

E-Response Data Packet Format (PC → RE-350)

When the PC receives the "Event Data Packet" from the RE-350, the PC should respond to the RE-350 with this data packet.

Header	ID number	Response number	Parameter	
B0h	* *h	* *h	MSH	LSH

FP Data Packet Format (PC ← RE-350)

In [NOTIFICATION] Mode, the RE-350 can notify the PC of the condition of each button and LED using this data packet.

Header	ID number	FP data number	Parameter	
30h	* *h	* *h	MSH	LSH

1.9 The Operational Flow Chart

There will be three kinds of communication flow between the RE-350 and the PC as follows:

Flow Pattern 1: Command Communication Flow Pattern

This flow will be applied when the PC sends a command to the RE-350 to request an operation.

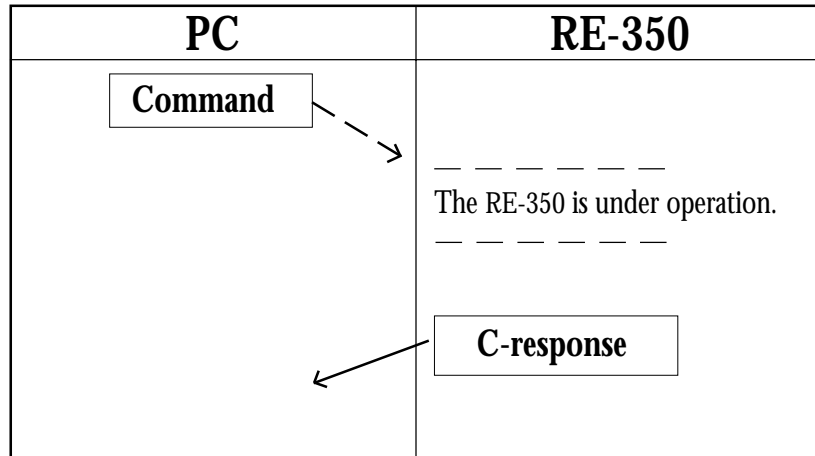

Flow Pattern 2: Event Packet Flow Pattern

This flow will be applied when the RE-350 sends an “Event Data Packet” to the PC to tell that the {RS-232} button on the operation panel was pressed.

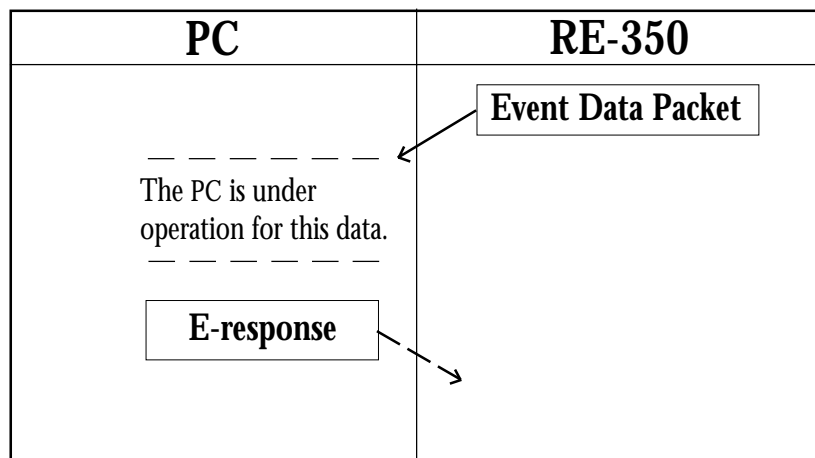

Flow Pattern 3: [NOTIFICATION] Mode Flow Pattern

This flow is applied when the RE-350 is in [NOTIFICATION] Mode to tell the PC the condition of the buttons and control knobs on the front panel of the RE-350.

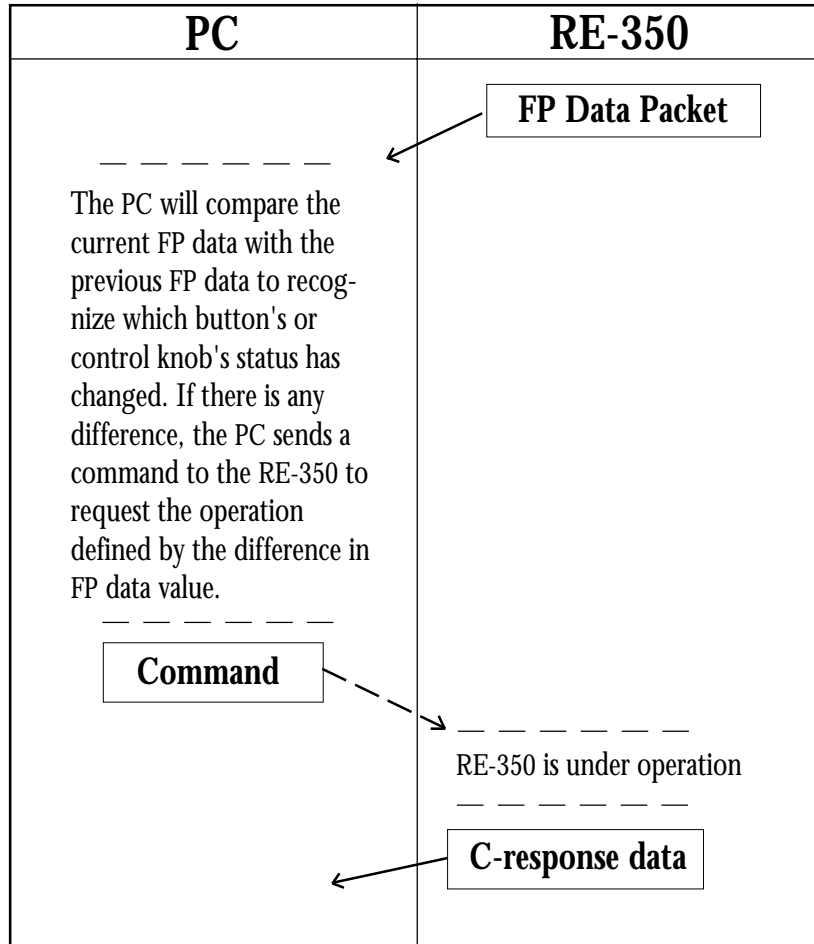

2.0 Control Command and Packet Tables

2.1 Camera Control Commands Table

#	Name	Description	Maximum operation time(ms)	1 byte Header	2 byte ID number	3 byte Command	4 byte Param(H)	5 byte Param(L)
Zoom								
1	Cons-Spd wide Zoom	High speed Wide zoom	500	\$10	\$8*	\$00	\$01	\$00
2	Step wide Zooming	Step feed wide zooming	2000	\$10	\$8*	\$00	\$03	\$00
3	Cons-Spd Tele Zoom	High speed Tele zoom	500	\$10	\$8*	\$01	\$01	\$00
4	Step Tele Zooming	Step feed tele zooming	2000	\$10	\$8*	\$01	\$03	\$00
5	Stop Zooming	Stop zooming motor	500	\$10	\$8*	\$02	\$00	\$00
6	Access-to-Zoom	Access to a Zoom Position	9000	\$10	\$8*	\$03	\$00	**
7	Request Zoom	Request Zoom position	100	\$10	\$8*	\$04	\$00	\$00
8	Wide Zoom w/ AF †	High spd Wide zoom w/AF	500	\$10	\$8*	\$05	\$00	\$00
9	Tele Zoom w/ AF †	High spd Tele zoom w/AF	500	\$10	\$8*	\$06	\$00	\$00
Focus								
10	OP AF	Operate auto focus	20000	\$10	\$8*	\$10	\$00	\$00
11	Cons-Spd focus near	High speed focus near	500	\$10	\$8*	\$12	\$01	\$00
12	Step focus near	Step feed focus near	2000	\$10	\$8*	\$12	\$03	\$00
13	Cons-Spd focus far	High speed focus far	500	\$10	\$8*	\$13	\$01	\$00
14	Step focus far	Step feed focus far	2000	\$10	\$8*	\$13	\$03	\$00
15	Stop focusing	Stop the auto focus	500	\$10	\$8*	\$14	\$00	\$00
Color								
16	OP AWB	Operate Auto White Bal.	7000	\$10	\$8*	\$20	\$00	\$00
17	Access to WB	Access to a WB position	500	\$10	\$8*	\$22	\$00	**
18	Access to EXP	Access to a EXP position	500	\$10	\$8*	\$2A	\$00	**
19	Access to Detail	Access to a Detail position	500	\$10	\$8*	\$30	\$00	**
20	Set Positive mode ††	Set positive image mode	500	\$10	\$8*	\$38	\$00	\$00
21	Set Negative mode ††	Set negative image mode	500	\$10	\$8*	\$38	\$01	\$00
22	Set Color mode	Set Color output mode	500	\$10	\$8*	\$40	\$00	\$00
23	Set B/W mode	Set B/W output mode	500	\$10	\$8*	\$40	\$01	\$00

† The RE-350 responds with a C-response data packet immediately after the reception of this command, but it is still working on the Zoom control and AF adjustment.

†† The RE-350 responds with a C-response data packet immediately after the reception of this command, but it is still working on the AWB adjustment.

2.2 System Control Commands Table

#	Name	Description	Maximum operation time(ms)	1 byte Header	2 byte ID number	3 byte Command	4 byte Param(H)	5 byte Param(L)
Select Input Signal								
1	Select Document Video	Output Camera signal	500	\$10	\$8*	\$50	\$00	\$00
2	Select External video	Output External signal	500	\$10	\$8*	\$50	\$01	\$00
Light on/off Control								
3	Lights On ^{††}	Turn Light On	500	\$10	\$8*	\$58	\$00	\$00
4	Lights Off ^{††}	Turn Light Off	500	\$10	\$8*	\$58	\$01	\$00
5	Backlight On ^{††}	Turn Backlight On	500	\$10	\$8*	\$59	\$00	\$00
6	Backlight Off ^{††}	Turn Backlight Off	500	\$10	\$8*	\$59	\$01	\$00
LED								
7	LED Normal	Set LED Condition Normal	500	\$10	\$8*	\$68	\$**	\$00
8	LED On	Turn LED On	500	\$10	\$8*	\$69	\$**	\$00
9	LED Off	Turn LED Off	500	\$10	\$8*	\$6A	\$**	\$00
10	LED Blink	Blink LED	500	\$10	\$8*	\$6B	\$**	\$00
Communication Control								
11	OFF Line	Set to [OFF LINE] Mode	500	\$10	\$8*	\$70	\$00	\$00
12	ON Line	Set to [ON LINE] Mode	500	\$10	\$8*	\$70	\$01	\$00
13	Notification	Set to [Notification] Mode	500	\$10	\$8*	\$70	\$02	\$00
Status Request								
14	Status of Group A	Request Status Group A	100	\$10	\$8*	\$80	\$00	\$00
15	Status of Group B	Request Status Group B	100	\$10	\$8*	\$80	\$01	\$00
16	Status of Button	Request Button condition	100	\$10	\$8*	\$81	\$00	\$00
17	Status of WB Control	Request WB vol. position	100	\$10	\$8*	\$82	\$00	\$00
18	Status of EXP Control	Request EXP vol. position	100	\$10	\$8*	\$82	\$01	\$00
19	Status of Detail Vol.	Request Detail vol. position	100	\$10	\$8*	\$82	\$02	\$00
20	Status of AWB Result	Request AWB result data	100	\$10	\$8*	\$83	\$00	\$00
21	Name of Equipment	Request Name of equip.	100	\$10	\$8*	\$88	\$00	\$00
22	Version of ROM	Request ROM version	100	\$10	\$8*	\$88	\$01	\$00
Set to Special Mode								
23	Set to Temporary Mode	Set to temp. mode	100	\$10	\$8*	\$F0	\$00	\$00
24	Set to Service Mode	Set to service mode	100	\$10	\$8*	\$F1	\$FF	\$FF
25	Set to Data Read Out	Set to data read mode	100	\$10	\$8*	\$F1	\$FF	\$00

^{††} The RE-350 responds with a C-response data packet immediately after the reception of this command, but it is still working on the AWB adjustment.

2.3 C-response Data Packet Table

C-response Description		1 byte Header	2 byte ID #	3 byte Response	4 byte Para(H)	5 byte Para(L)
Normal Response	Response without parameter	\$A0	\$8*	\$00	\$00	\$00
	Read Zoom position	\$A0	\$8*	\$10	\$00	\$**
	Status of Group A	\$A0	\$8*	\$20	\$**	\$**
	Status of Group B	\$A0	\$8*	\$21	\$**	\$00
	Status of Button	\$A0	\$8*	\$30	\$**	\$**
	Status of WB control knob	\$A0	\$8*	\$40	\$00	\$**
	Status of EXP control knob	\$A0	\$8*	\$41	\$00	\$**
	Status of Detail control knob	\$A0	\$8*	\$42	\$00	\$**
	Status of AWB result	\$A0	\$8*	\$43	\$00	\$**
	Name of the Equipment	\$A0	\$8*	\$48	\$**	\$**
	Version of ROM	\$A0	\$8*	\$49	\$**	\$**
Error Response	System Error	\$A0	\$8*	\$F0	\$00	\$00
	Mode Error	\$A0	\$8*	\$F0	\$00	\$01
	Time out error	\$A0	\$8*	\$F0	\$00	\$02

System error response

If the RE-350 has a fatal error which it cannot recover from while performing a command from the PC, the RE-350 will send this response and stop the current operation.

Mode error response

Depending on the mode, [ON-LINE] or [OFF-LINE], the RE-350 may not be able to execute some commands. In this case, the Mode error response will be sent to the PC.

For Example: If the RE-350 is in the [OFF-LINE] Mode and the <Zoom Wide> command is issued, the RE-350 will give a Mode error response because in this mode such a command cannot be executed.

Time out error response

When the RE-350 is given the command <OP AF> or <OP AWB> from the PC and it tries to perform the command but cannot finish the operation successfully in an expected period, this error is given.

2.4 Event Data Packet Table

Event Description	1 byte Header	2 byte ID #	3 byte EVENT#	4 byte Para(H)	5 byte Para(L)
Request ON Line	\$20	\$8*	\$00	\$00	\$00
Request OFF Line	\$20	\$8*	\$00	\$01	\$00

Request ON line

When the {RS-232} button on the front panel is pushed and the RTS signal line from the PC is on, the RE-350 will send this "Event Data Packet" to the PC. If the RE-350 can receive the <Accepted> of the "E-response Packet" in 1 second, the RE-350's mode will switch to [ON-LINE]. If not or no E-response after repeating the above "Event data packet" twice, the RE-350 will stay in [OFF-LINE] mode.

Request OFF line

When the {RS-232} button on the front panel is pushed to try to set the RE-350 to [OFF-LINE] Mode and the RTS signal line from the PC is on, the RE-350 will send this "Event Data Packet" to the PC. If the RE-350 can receive the <Accepted> of the "E-response packet", the RE-350's mode will shift to the [OFF-LINE] Mode. Also, if there is no response from the PC, then the RE-350's mode changes to [OFF-LINE].

2.5 E-response Data Packet Table

E-response Description	1 byte Header	2 byte ID #	3 byte EVENT#	4 byte Para(H)	5 byte Para(L)
Accepted	\$B0	\$8*	\$00	\$00	\$00
Denied	\$B0	\$8*	\$00	\$01	\$00

Accepted

When the PC receives an “Event Data Packet” (‘Request ON line’ or ‘Request OFF line’) from the RE-350, the PC should send this E-response packet back to the RE-350 to tell that the PC can disconnect from or connect to the RE-350. After the RE-350 receives this request, it takes one second to complete.

Denied

When the PC receives an “Event Data Packet” (‘Request ON line’ or ‘Request OFF line’) from the RE-350, and the PC cannot accept this request, the PC should send this response packet to the RE-350. After the RE-350 receives this request, it takes one second to complete.

2.6 FP Data Packet Table

FP data description	1 byte Header	2 byte ID #	3 byte EVENT#	4 byte Para(H)	5 byte Para(L)
Front panel switch information	\$30	\$8*	\$00	\$**	\$**

FP Data Packet

When the RE-350 is in [NOTIFICATION] Mode, it will send the “FP Data Packet” to the PC. This tells the condition of each button and control knob every time the condition varies.

The bit assignment of the parameter is as follows:

D15	D14	D13	D12	D11	D10	D9	D8
W/B Vol	0	Focus Auto	B/W	W/B Auto	Nega	Inputselect	0

D7	D6	D5	D4	D3	D2	D1	D0
Detail Vol	EXP Vol	Back light	Lights	Zoom Tele	Zoom Wide	Focus Far	Focus Near

If a control knob has not been used for longer than 500 milliseconds, the RE-350 will send the “FP-Data Packet” with the corresponding control knob bit cleared.

Note: If the RTS signal line of the PC is off and the RE-350 is in [NOTIFICATION] Mode, the RE-350 will start to send the “FP-Data Packet” which explains the button and control knob condition at the time when the RTS signal line comes on.

3.0 Description Command Data Packet

3.1 Zoom Commands

Wide Zoom: Constant Speed

- Function:
Moves the zoom lens in the wider direction at a constant speed. This operation will be stopped with the reception of the <Stop Zooming> command or if the zoom lens reaches the wide-end limit.
- Timing of the “C-response Packet” sent to the PC:
Right after the zoom lens start to move.
- The parameter of the “C-response Packet”:
\$0000 fixed
- The maximum operation time (msec):
500 millisecond
- Command format:

Header	ID number	Command	Parameter MSH	Parameter LSH
\$10	\$ 8 *	\$ 0 0	\$ 0 1	\$ 0 0

Note: The speed of the zooming will be constant from the beginning to the end of this operation. This is different from when the {ZOOM WIDE} button on the front panel is pushed. If the {ZOOM WIDE} button is pushed and continues to be pushed for longer than one second, the zooming will increase to a faster speed.

Wide Zoom: Step

- Function:
Moves the zoom lens in the wider direction one step. This operation will be stopped automatically after the zoom lens has stopped.
- Timing of the “C-response packet” sent to the PC:
Right after the zoom lens stops.
- The parameter of the “C-response packet”:
\$0000 fixed
- The maximum operation time (msec):
2000 millisecond
- Command format:

Header	ID number	Command	Parameter MSH	Parameter LSH
\$10	\$ 8 *	\$ 0 0	\$ 0 3	\$ 0 0

Tele Zoom: Constant Speed

- Function:
Moves the zoom lens in the tele direction at a constant speed. This operation will be stopped with the reception of the <Stop Zooming> command or the zoom lens reaches the tele-end limit.
- Timing of the “C-response Packet” sent to the PC:
Right after the zoom lens start to move.
- The parameter of the “C-response Packet”:
\$0000 fixed
- The maximum operation time (msec):
500 millisecond
- Command format:

Header	ID number	Command	Parameter MSH	Parameter LSH
\$10	\$ 8 *	\$ 0 1	\$ 0 1	\$ 0 0

Note: The speed of the zooming will be constant from the beginning to the end of this operation. This is different from when the {ZOOM TELE} button on the panel is pushed. If the {ZOOM TELE} button is pushed and continues to be pushed for longer than one second, the zooming will increase to a faster speed.

Tele Zoom: Step

- Function:
Moves the zoom lens in the tele direction one step. This operation will be stopped automatically after the zoom lens has stepped.
- Timing of the “C-response Packet” sent to the PC:
Right after the zoom lens stops.
- The parameter of the “C-response Packet”:
\$0000 fixed
- The maximum operation time (msec):
2000 millisecond
- Command format:

Header	ID number	Command	Parameter MSH	Parameter LSH
\$10	\$ 8 *	\$ 0 1	\$ 0 3	\$ 0 0

Zoom: Stop

- Function:
Stops the movement of the zooming lens.
- Timing of the “C-response Packet” sent to the PC:
Right after the zoom lens stops to move.
- The parameter of the “C-response Packet”:
\$0000 fixed
- The maximum operation time (msec):
500 millisecond
- Command format:

Header	ID number	Command	Parameter MSH	Parameter LSH
\$10	\$ 8 *	\$ 0 2	\$ 0 0	\$ 0 0

Zoom: Access To Position

- Function:
Moves the zoom lens to a designated position determined by the parameter in this command packet.
- The available parameter value:
LSH: \$00 ~ \$FF
- Timing of the “C-response Packet” sent to the PC:
Right after the zoom lens reaches the designated position.
- The parameter of the “C-response Packet”:
\$0000 fixed
- The maximum operation time (msec):
9000 millisecond
- Command format:

Header	ID number	Command	Parameter MSH	Parameter LSH
\$10	\$ 8 *	\$ 0 3	\$ 0 0	\$ * *

Zoom: Request Position

- Function:
Requests the present position of the zoom lens from the RE-350.
- Timing of the “C-response Packet” sent to the PC:
Right after this command is accepted by the RE-350.
- The parameter of the “C-response Packet”:
The present zoom lens position data:
MSH:\$00 fixed LSH:\$00 ~ \$FF
- The maximum operation time (msec):
100 millisecond
- Command format:

Header	ID number	Command	Parameter MSH	Parameter LSH
\$10	\$ 8 *	\$ 0 4	\$ 0 0	\$ 0 0

Zoom Wide: Constant Speed w/ AF †

- Function:
Moves the zoom lens in the wider direction at a constant speed. This operation will be stopped with the reception of the <Stop Zooming> command or if the zoom lens reaches the wide-end limit.
- Timing of the “C-response Packet” sent to the PC:
Right after the zoom lens start to move.
- The parameter of the “C-response Packet”:
\$0000 fixed
- The maximum operation time (msec):
500 millisecond
- Command format:

Header	ID number	Command	Parameter MSH	Parameter LSH
\$10	\$ 8 *	\$ 0 5	\$ 0 0	\$ 0 0

Zoom Tele: Constant Speed w/ AF †

- Function:
Moves the zoom lens in the tele direction at a constant speed. This operation will be stopped with the reception of the <Stop Zooming> command or the zoom lens reaches the tele-end limit.
- Timing of the “C-response Packet” sent to the PC:
Right after the zoom lens start to move.
- The parameter of the “C-response Packet”:
\$0000 fixed
- The maximum operation time (msec):
500 millisecond
- Command format:

Header	ID number	Command	Parameter MSH	Parameter LSH
\$10	\$ 8 *	\$ 0 6	\$ 0 0	\$ 0 0

† The speed of the zooming will be constant from the beginning to the end of this operation. This is different from when the {ZOOM WIDE} or {ZOOM TELE} button on the front panel is pushed. If the {ZOOM WIDE} or {ZOOM TELE} button is pushed and continues to be pushed for longer than one second, the zooming will increase to a faster speed.

The RE-350 responds with a C-response data packet immediately after the reception of this command, but it is still working on the Zoom control and AF adjustment.

3.2 Focus Commands

OP AF (Operate Auto Focus)

- Function:
Perform AF once, finding out the best focused position.
- Timing of the “C-response Packet” sent to the PC:
Right after having found out the best focal point or, after a 6 second trial, having failed to find the best focal point.
- The parameter of the “C-response Packet”:
\$0000 fixed
- The maximum operation time (msec):
20000 millisecond
- Command format:

Header	ID number	Command	Parameter MSH	Parameter LSH
\$10	\$ 8 *	\$ 1 0	\$ 0 0	\$ 0 0

Focus Near: Constant Speed

- Function:
Moves the focus lens in the near direction at a constant speed. This operation will be stopped with the reception of the <Stop focusing> command or the focus lens reaches the near-end limit.
- Timing of the “C-response Packet” sent to the PC:
Right after the focus lens starts to move.
- The parameter of the “C-response Packet”:
\$0000 fixed
- The maximum operation time (msec):
500 millisecond
- Command format:

Header	ID number	Command	Parameter MSH	Parameter LSH
\$10	\$ 8 *	\$1 2	\$ 0 1	\$ 0 0

Focus Near: Step

- Function:
Moves the focus lens in the near direction one step.
This operation will be stopped automatically.
- Timing of the “C-response Packet” sent to the PC:
Right after the focus lens stops.
- The parameter of the “C-response Packet”:
\$0000 fixed
- The maximum operation time (msec):
2000 millisecond
- Command format:

Header	ID number	Command	Parameter MSH	Parameter LSH
\$10	\$ 8 *	\$ 1 2	\$ 0 3	\$ 0 0

Focus Far: Constant Speed

- Function:
Moves the focus lens in the far direction at a constant speed. This operation will be stopped with the reception of the <Stop focusing> command or the focus lens reaches the far-end limit.
- Timing of the “C-response Packet” sent to the PC:
Right after the focus lens starts to move.
- The parameter of the “C-response Packet”:
\$0000 fixed
- The maximum operation time (msec):
500 millisecond
- Command format:

Header	ID number	Command	Parameter MSH	Parameter LSH
\$10	\$ 8 *	\$ 1 3	\$ 0 1	\$ 0 0

Focus Far: Step

- Function:
Moves the focus lens in the far direction one step. This operation stops automatically.
- Timing of the “C-response Packet” sent to the PC:
Right after the focus lens stops
- The parameter of the “C-response Packet”:
\$0000 fixed
- The maximum operation time (msec):
2000 millisecond
- Command format:

Header	ID number	Command	Parameter MSH	Parameter LSH
\$10	\$ 8 *	\$ 1 3	\$ 0 3	\$ 0 0

Focus: Stop

- Function:
Stops the focusing motor that moves the focus lens.
- Timing of the “C-response Packet” sent to the PC:
Right after the focus lens stops.
- The parameter of the “C-response Packet”:
\$0000 fixed
- The maximum operation time (msec):
500 millisecond
- Command format:

Header	ID number	Command	Parameter MSH	Parameter LSH
\$10	\$ 8 *	\$1 4	\$ 0 0	\$ 0 0

3.3 White Balance Commands

OP AWB (Operate Auto-White Balance)

- Function:
Instructs the auto white balance to find the best white balance.
- Timing of the “C-response Packet” sent to the PC:
Right after having found out the best white balance point or, after 6 seconds, having failed to find a proper WB.
- The parameter of the “C-response Packet”:
\$0000 fixed
- The maximum operation time (msec):
7000 millisecond
- Command format:

Header	ID number	Command	Parameter MSH	Parameter LSH
\$10	\$ 8 *	\$ 2 0	\$ 0 0	\$ 0 0

White Balance: Manual Access To

- Function:
Sets a designated white balance position, which is determined by the parameter of this command, based on the Auto White Balance value as returned by the <Status of AWB Result> command (p.51). The AWB value should be known so the adjustment can be made properly, in the correct direction. This command is similar to rotating the manual control knob on the front panel. **Note:** The control knob’s physical position is not updated by this command.
- Available parameter value:
LSH: \$ 00 ~ \$ FF
- Timing of the “C-response Packet” sent to the PC:
Right after the compensation of WB is performed.
- The parameter of the “C-response Packet”:
\$0000 fixed
- The maximum operation time (msec):
500 millisecond
- Command format:

Header	ID number	Command	Parameter MSH	Parameter LSH
\$10	\$ 8 *	\$ 2 2	\$ 0 0	\$ * *

3.4 Exposure Commands

Exposure: Manual Access To

- Function:
Sets a designated exposure position, which is determined by the parameter of this command. The result is the same as rotating the manual control knob on the front panel.

Note:

The control knob's physical position is not updated by this command.
This command simply modifies the target exposure default value which is \$80.

- Available parameter value:
LSH: \$ 00 (darker)~ \$ FF (brighter)
- Timing of the "C-response Packet" sent to the PC:
Right after the Manual Exposure command is performed.
- The parameter of the "C-response Packet":
\$0000 fixed
- The maximum operation time (msec):
500 millisecond
- Command format:

Header	ID number	Command	Parameter MSH	Parameter LSH
\$10	\$ 8 *	\$ 2A	\$ 0 0	\$* *

3.5 Detail Commands

Detail: Manual Access To

- **Function:**
Sets a designated sharpness position, which is determined by the parameter of this command. The result is the same as rotating the manual control knob on the front panel.

Note:

The control knob's physical position is not updated by this command.
This command simply modifies the target exposure default value which is \$80.

- **Available parameter value:**
LSH: \$ 00 (less detail)~ \$ FF (more detail)
- **Timing of the "C-response Packet" sent to the PC:**
Right after the sharpness is adjusted.
- **The parameter of the "C-response Packet":**
\$0000 fixed
- **The maximum operation time (msec):**
500 millisecond
- **Command format:**

Header	ID number	Command	Parameter MSH	Parameter LSH
\$10	\$ 8 *	\$3 0	\$ 0 0	\$ * *

3.6 Positive/Negative Commands

Set Positive Mode †

- Function:
Sets the video output to normal (positive). (Also, the Auto-White Balance will be adjusted once.)
- Timing of the “C-response Packet” sent to the PC:
Right after this setting is done.
- The parameter of the “C-response Packet”:
\$0000 fixed
- The maximum operation time (msec):
500 millisecond
- Command format:

Header	ID number	Command	Parameter MSH	Parameter LSH
\$10	\$ 8 *	\$ 3 8	\$ 0 0	\$ 0 0

Set Negative Mode †

- Function:
Sets the video output to negative. (Also, the Auto-White Balance will be adjusted once.)
- Timing of the “C-response Packet” sent to the PC:
Right after this setting is done.
- The parameter of the “C-response Packet”:
\$0000 fixed
- The maximum operation time (msec):
500 millisecond
- Command format:

Header	ID number	Command	Parameter MSH	Parameter LSH
\$10	\$ 8 *	\$ 3 8	\$ 0 1	\$ 0 0

† The RE-350 responds in 500 msec with a C-response data packet after the reception of this command, but it will be still working on the AWB adjustment. (The real AWB operation time will be longer than 500 msec.)

3.7 Color/B&W Commands

Set Color Mode

- Function:
Sets the video output to color.
- Timing of the “C-response Packet” sent to the PC:
Right after this setting is done.
- The parameter of the “C-response Packet”:
\$0000 fixed
- The maximum operation time (msec):
500 millisecond
- Command format:

Header	ID number	Command	Parameter MSH	Parameter LSH
\$10	\$ 8 *	\$ 4 0	\$ 0 0	\$ 0 0

Set B/W Mode

- Function:
Sets the video output to black & white.
- Timing of the “C-response Packet” sent to the PC:
Right after this setting is done.
- The parameter of the “C-response Packet”:
\$0000 fixed
- The maximum operation time (msec):
500 millisecond
- Command format:

Header	ID number	Command	Parameter MSH	Parameter LSH
\$10	\$ 8 *	\$ 4 0	\$ 0 1	\$ 0 0

4.0 System Control Commands

4.1 Detailed System Control Commands

Select Document Video

- Function:
Selects the Document camera video.
- Timing of the “C-response Packet” sent to the PC:
Right after this setting is done.
- The parameter of the “C-response Packet”:
\$0000 fixed
- The maximum operation time (msec):
500 millisecond
- Command format:

Header	ID number	Command	Parameter MSH	Parameter LSH
\$10	\$ 8 *	\$ 5 0	\$ 0 0	\$ 0 0

Select External Video

- Function:
Selects the external video input signal.
- Timing of the “C-response Packet” sent to the PC:
Right after this setting is done.
- The parameter of the “C-response Packet”:
\$0000 fixed
- The maximum operation time (msec):
500 millisecond
- Command format:

Header	ID number	Command	Parameter MSH	Parameter LSH
\$10	\$ 8 *	\$5 0	\$ 0 1	\$ 0 0

Document Lights: On †

- Function:
Turns on the document lights above the document table. (Also, the Auto-White Balance will be adjusted once.)

Note: If the Backlight is already on, and the Document Lights are turned on, then the Backlight will be turned off automatically and only the Document Lights will remain on.

- Timing of the “C-response Packet” sent to the PC:
Right after turning on the lights.
- The parameter of the “C-response Packet”:
\$0000 fixed
- The maximum operation time (msec):
500 millisecond
- Command format:

Header	ID number	Command	Parameter MSH	Parameter LSH
\$10	\$ 8 *	\$ 5 8	\$ 0 0	\$ 0 0

Document Lights: Off †

- Function:
Turns off the Document Lights above the document table. (Also, the Auto-White Balance will be adjusted once.)
- Timing of the “C-response Packet” sent to the PC:
Right after turning off the lights.
- The parameter of the “C-response Packet”:
\$0000 fixed
- The maximum operation time (msec):
500 millisecond
- Command format:

Header	ID number	Command	Parameter MSH	Parameter LSH
\$10	\$ 8 *	\$5 8	\$ 0 1	\$ 0 0

† The RE-350 responds in 500 msec with a C-response data packet after the reception of this command, but it will be still working on the AWB adjustment. (The real AWB operation time will be longer than 500 msec.)

Backlight: On †

- Function:
Turns on the Backlight under the document table. (Also, the Auto-White Balance will be adjusted once.)

Note: If the Document Lights are already on, and the Backlight is turned on, then the Document Lights will be turned off automatically and only the backlight will remain on.

- Timing of the “C-response Packet” sent to the PC:
Right after turning on the backlight.
- The parameter of the “C-response Packet”:
\$0000 fixed
- The maximum operation time (msec):
500 millisecond
- Command format:

Header	ID number	Command	Parameter MSH	Parameter LSH
\$10	\$ 8 *	\$ 5 9	\$ 0	\$ 0 0

Backlight: Off †

- Function:
Turns off the document lights above the document table. (Also, the Auto-White Balance will be adjusted once.)
- Timing of the “C-response Packet” sent to the PC:
Right after turning off the backlight.
- The parameter of the “C-response Packet”:
\$0000 fixed
- The maximum operation time (msec):
500 millisecond
- Command format:

Header	ID number	Command	Parameter MSH	Parameter LSH
\$10	\$ 8 *	\$5 9	\$ 0 1	\$ 0 0

† The RE-350 responds in 500 msec with a C-response data packet after the reception of this command, but it will be still working on the AWB adjustment. (The real AWB operation time will be longer than 500 msec.)

LED: Normal

- **Function:**
The LED indicated by the parameter data will be set to normal operation. This command is available in the [NOTIFICATION] Mode. If the RE-350 receives this command from the PC in another mode, the RE-350 will send a “C-response Packet” with the Mode Error response.
- **The available parameter value:**
LSH: \$00 ~ \$FF
- **Timing of the “C-response Packet” sent to the PC:**
Right after this setting is done.
- **The parameter of the “C-response Packet”:**
\$0000 fixed
- **The maximum operation time (msec):**
500 millisecond
- **Command format:**

Header	ID number	Command	Parameter MSH	Parameter LSH
\$10	\$ 8 *	\$ 6 8	\$ * *	\$ 0 0

- **The bit assignment for the parameter data:**
Each bit corresponds to each LED on the operation panel.

D15	D14	D13	D12	D11	D10	D9	D8
RS-232	Input select	NEGA	WB Auto	B/W	Focus Auto	Lights	Backlight

LED: On

- **Function:**
The LED indicated by the parameter data will be turned on. This command is available in the [NOTIFICATION] Mode. If the RE-350 receives this command from the PC in another mode, the RE-350 will send a “C-response Packet” with the Mode Error response.
- **The available parameter value:**
LSH: \$00 ~ \$FF
- **Timing of the “C-response Packet” sent to the PC:**
Right after this setting is done.
- **The parameter of the “C-response Packet”:**
\$0000 fixed
- **The maximum operation time (msec):**
500 millisecond
- **Command format:**

Header	ID number	Command	Parameter MSH	Parameter LSH
\$10	\$ 8 *	\$ 6 9	\$ * *	\$ 0 0

- **The bit assignment for the parameter data:**
Each bit corresponds to each LED on the operation panel.

D15	D14	D13	D12	D11	D10	D9	D8
RS-232	Input select	NEGA	WB Auto	B/W	Focus Auto	Lights	Backlight

LED: Off

- **Function:**
The LED indicated by the parameter data will be turned off. This command is available in the [NOTIFICATION] Mode. If the RE-350 receives this command from the PC in another mode, the RE-350 will send a “C-response Packet” with the Mode Error response.
- **The available parameter value:**
LSH: \$00 ~ \$FF
- **Timing of the “C-response packet” sent to the PC:**
Right after this setting is done.
- **The parameter of the “C-response packet”:**
\$0000 fixed
- **The maximum operation time (msec):**
500 millisecond
- **Command format:**

Header	ID number	Command	Parameter MSH	Parameter LSH
\$10	\$ 8 *	\$ 6 A	\$ * *	\$ 0 0

- **The bit assignment for the parameter data:**
Each bit corresponds to each LED on the operation panel.

D15	D14	D13	D12	D11	D10	D9	D8
RS-232	Input select	NEGA	W/B Auto	B/W	Focus Auto	Lights	Backlight

LED: Blink

- **Function:**
The LED indicated by the parameter data will be made to blink. This command is available in the [NOTIFICATION] Mode. If the RE-350 receives this command from the PC in another mode, the RE-350 will send a “C-response Packet” with the Mode Error response.
- **The available parameter value:**
LSH: \$00 ~ \$FF
- **Timing of the “C-response Packet” sent to the PC:**
Right after this setting is done.
- **The parameter of the “C-response Packet”:**
\$0000 fixed
- **The maximum operation time (msec):**
500 millisecond
- **Command format:**

Header	ID number	Command	Parameter MSH	Parameter LSH
\$10	\$ 8 *	\$ 6 B	\$ * *	\$ 0 0

- **The bit assignment for the parameter data:**
Each bit corresponds to each LED on the operation panel.

D15	D14	D13	D12	D11	D10	D9	D8
RS-232	Input select	NEGA	W/B Auto	B/W	Focus Auto	Lights	Backlight

[OFF-LINE] Mode

- Function:
Sets the RE-350 to [OFF-LINE] Mode.
- Timing of the “C-response Packet” sent to the PC:
Right after this setting is done.
- The parameter of the “C-response Packet”:
\$0000 fixed
- The maximum operation time (msec):
500 millisecond
- Command format:

Header	ID number	Command	Parameter MSH	Parameter LSH
\$10	\$ 8 *	\$ 7 0	\$ 0 0	\$ 0 0

[ON-LINE] Mode

- Function:
Sets the RE-350 to [ON-LINE] Mode.
- Timing of the “C-response Packet” sent to the PC:
Right after this setting is done.
- The parameter of the “C-response Packet”:
\$0000 fixed
- The maximum operation time (msec):
500 millisecond
- Command format:

Header	ID number	Command	Parameter MSH	Parameter LSH
\$10	\$ 8 *	\$ 7 0	\$ 0 1	\$ 0 0

[NOTIFICATION] Mode

- Function:
Sets the RE-350 to [NOTIFICATION] Mode.
- Timing of the “C-response Packet” sent to the PC:
Right after this setting is done.
- The parameter of the “C-response Packet”:
\$0000 fixed
- The maximum operation time (msec):
500 millisecond
- Command format:

Header	ID number	Command	Parameter MSH	Parameter LSH
\$10	\$ 8 *	\$ 7 0	\$ 0 2	\$ 0 0

Status of Group A

- Function:
To get the status data of Group A from the RE-350 .
- Timing of the “C-response Packet” sent to the PC:
Right after this command is received by the RE-350.
- The parameter of the “C-response Packet”:
The bit assignment to each status to explain the RE-350’s condition.

D15	D14	D13	D12	D11	D10	D9	D8
On-zoom Wide	On-zoom Tele	At-zoom Wide-end	At-zoom Tele-end	On-focus Far	On-focus Near	At-focus Far-end	At-focus Near-end
D7	D6	D5	D4	D3	D2	D1	D0
0	0	AF good/NG	AWB good/NG	0	VideoP/N	VideoC/M	0

Note:

Good	---> 1	NG	---> 0
P (posi)	---> 1	N(nega)	---> 0
C(color)	---> 1	M(mono)	---> 0
On-zoom: actively zooming,		At-zoom: Arrived at the maximum zoom position.	
On-focus: actively focusing,		At-focus: Arrived at the maximum focal position.	

- The maximum operation time (msec):
100 millisecond
- Command format:

Header	ID number	Command	Parameter MSH	Parameter LSH
\$10	\$ 8 *	\$ 8 0	\$ 0 0	\$ 0 0

Status of Group B

- Function:
To get the status data of Group B from the RE-350 .
- Timing of the “C-response Packet” sent to the PC:
Right after this command is received by the RE-350.
- The parameter of the “C-response Packet”:
The bit assignment to each status to explain the RE-350’s condition.

D15	D14	D13	D12	D11	D10	D9	D8
Input Camera/Ext	Lights ON/OFF	Backlight ON/OFF	C MODE 1	C MODE 0	0	0	0
D7	D6	D5	D4	D3	D2	D1	D0
0	0	0	0	0	0	0	0

Note:

1 = ON 0 = OFF

C MODE 1 and C MODE 0 explain the operational mode of the RE-350 as follows:

MODE	C MODE 1	C MODE 0
OFF-LINE	--	--
ON-LINE	0	1
NOTIFICATION	1	0
not used	1	1

- The maximum operation time (msec):
100 millisecond
- Command format:

Header	ID number	Command	Parameter MSH	Parameter LSH
\$10	\$ 8 *	\$ 8 0	\$ 0 1	\$ 0 0

Status of the Buttons

- Function:
To get the status of the buttons on the operation panel .
- Timing of the “C-response Packet” sent to the PC:
Right after this command is received by the RE-350.
- The parameter of the “C-response Packet”:
The bit assignment to each status to explain the RE-350’s condition.

D15	D14	D13	D12	D11	D10	D9	D8
0	0	Focus Auto	B/W	W/B	NEGA	Input Select	RS-232 Control
D7	D6	D5	D4	D3	D2	D1	D0
0	0	Backlight	Lights	Zoom TELE	Zoom WIDE	Focus FAR	Focus NEAR

- The maximum operation time (msec):
100 millisecond
- Command format:

Header	ID number	Command	Parameter MSH	Parameter LSH
\$10	\$ 8 *	\$ 8 1	\$ 0 0	\$ 0 0

Status of WB control knob

- Function:
Gets the position data of the White Balance Manual control knob.
- Timing of the “C-response Packet” sent to the PC:
Right after this command is received by the RE-350.
- The parameter of the “C-response Packet”:
MSH: \$00 fixed LSH: \$00 ~ \$FF
- The maximum operation time (msec):
100 millisecond
- Command format:

Header	ID number	Command	Parameter MSH	Parameter LSH
\$10	\$ 8 *	\$ 82	\$ 0 0	\$ 0 0

Status of EXP control knob

- Function:
Gets the position data of the EXP control knob. (EXP = exposure)
- Timing of the “C-response Packet” sent to the PC:
Right after this command is received by the RE-350.
- The parameter of the “C-response Packet”:
MSH: \$00 fixed LSH: \$00 ~ \$FF
- The maximum operation time (msec):
100 millisecond
- Command format:

Header	ID number	Command	Parameter MSH	Parameter LSH
\$10	\$ 8 *	\$ 82	\$ 0 1	\$ 0 0

Status of Detail control knob

- Function:
Gets the position data of the Detail control knob.
- Timing of the “C-response Packet” sent to the PC:
Right after this command is received by the RE-350.
- The parameter of the “C-response Packet”:
MSH: \$00 fixed LSH: \$00 ~ \$FF
- The maximum operation time (msec):
100 millisecond
- Command format:

Header	ID number	Command	Parameter MSH	Parameter LSH
\$10	\$ 8 *	\$ 8 2	\$ 0 2	\$ 0 0

Status of AWB result

- Function:
Gets the position data of the White Balance Manual control knob where Auto-White Balance is completed.
- Timing of the “C-response Packet” sent to the PC:
Right after this command is received by the RE-350.
- The parameter of the “C-response Packet”:
MSH: \$00 fixed LSH: \$00 ~ \$FF
- The maximum operation time (msec):
100 millisecond
- Command format:

Header	ID number	Command	Parameter MSH	Parameter LSH
\$10	\$ 8 *	\$ 8 3	\$ 0 0	\$ 0 0

Name of the Equipment

- Function:
Gets the code name of the equipment which is connected to the PC.
The code name of the RE-350 is "R1".
- Timing of the "C-response Packet" sent to the PC:
Right after this command is received by the RE-350.
- The parameter of the "C-response Packet":
MSH: fixed LSH: fixed
The code name of the RE-350 is "R1".
- The maximum operation time (msec):
100 millisecond
- Command format:

Header	ID number	Command	Parameter MSH	Parameter LSH
\$10	\$ 8 *	\$ 8 8	\$ 0 0	\$ 0 0

Version of ROM

- Function:
Gets the coded version number from each of the RE-350's ROM's.
- Timing of the "C-response Packet" sent to the PC:
Right after this command is received by the RE-350.
- The parameter of the "C-response Packet":
MSH: \$XX LSH: \$XX
The MSH parameter is the ROM version of the RE-350's camera head CPU.
The LSH parameter is the ROM version of the RE-350's main body CPU.
The above parameters (in ASCII Code) are variable and are set by the firmware.
- The maximum operation time (msec):
100 millisecond
- Command format:

Header	ID number	Command	Parameter MSH	Parameter LSH
\$10	\$ 8 *	\$ 8 8	\$ 0 1	\$ 0 0

Set to Special Mode 1

- Function:
Lets the RE-350 transfer to Special Mode 1. The RE-350 will accept this command independently from its ID number.
- Timing of the “C-response Packet” sent to the PC:
Right after this command is received by the RE-350.
- The parameter of the “C-response Packet”:
MSH: \$00 fixed LSH: \$00 fixed
- The maximum operation time (msec):
100 millisecond
- Command format:

Header	ID number	Command	Parameter MSH	Parameter LSH
\$10	\$ 8 *	\$F 0	\$ 0 0	\$ 0 0

Note: This command is prepared for service purposes ONLY and it is not intended for use by the end-user.

Set to Special Mode 2

- Function:
Lets the RE-350 transfer to Special Mode 2. The RE-350 will accept this command independently from its ID number.
- Timing of the “C-response Packet” sent to the PC:
Right after this command is received by the RE-350.
- The parameter of the “C-response Packet”:
MSH: \$00 fixed LSH: \$00 fixed
- The maximum operation time (msec):
100 millisecond
- Command format:

Header	ID number	Command	Parameter MSH	Parameter LSH
\$10	\$ 8 *	\$F 1	\$F F	\$ 0 0

Note: This command is prepared for service purposes ONLY and it is not intended for use by the end-user.

Set to Service Mode

- Function:
Lets the RE-350 transfer to Service Mode. The RE-350 will accept this command independently from its ID number.
- Timing of the “C-response Packet” sent to the PC:
Right after this command is received by the RE-350.
- The parameter of the “C-response Packet”:
MSH: \$00 fixed LSH: \$00 fixed
- The maximum operation time (msec):
100 millisecond
- Command format:

Header	ID number	Command	Parameter MSH	Parameter LSH
\$10	\$ 8 *	\$F 1	\$F F	\$ F F

Note: This command is prepared for service purposes ONLY and it is not intended for use by the end-user.

5.0 Control Cable Pin Assignments

5.1 RS-232C Control Cable Pin Assignment

25 pin DSUB to 8 pin (Camera) Connection

Below is a cable pin out of the cable required to control the Canon RE-350 camera from a computer with a 25 pin control port.

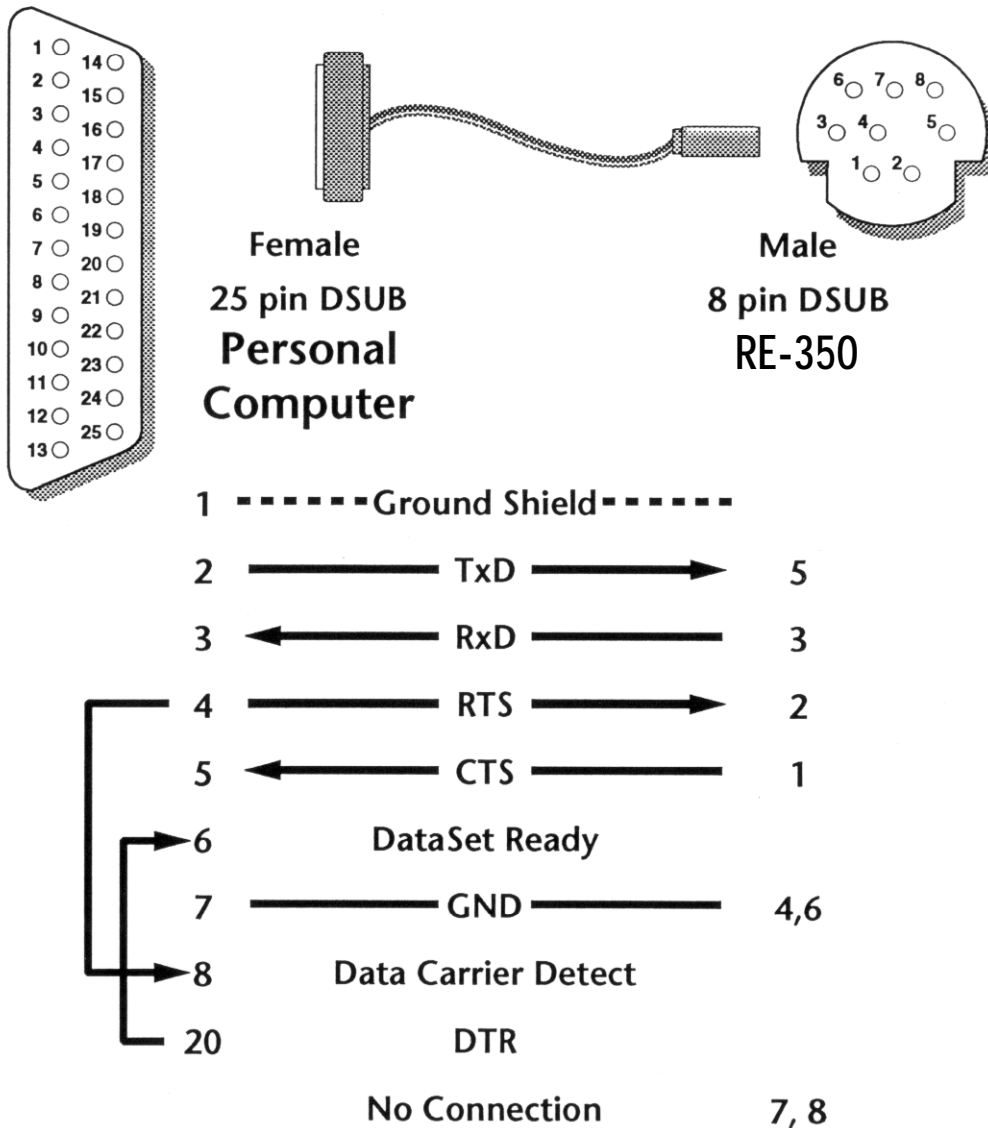

RE-350 Control Cable Pin Assignments 9 Pin DSUB RS-232C

9 pin DSUB to 8 pin DSUB (Camera) Connection

Below is a cable pin out of the cable required to control the Canon RE-350 camera from a computer with a 9 pin control port.

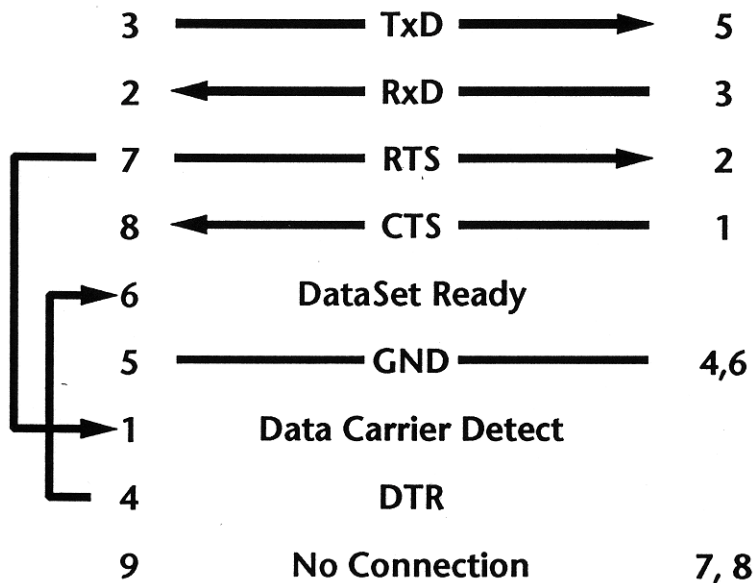
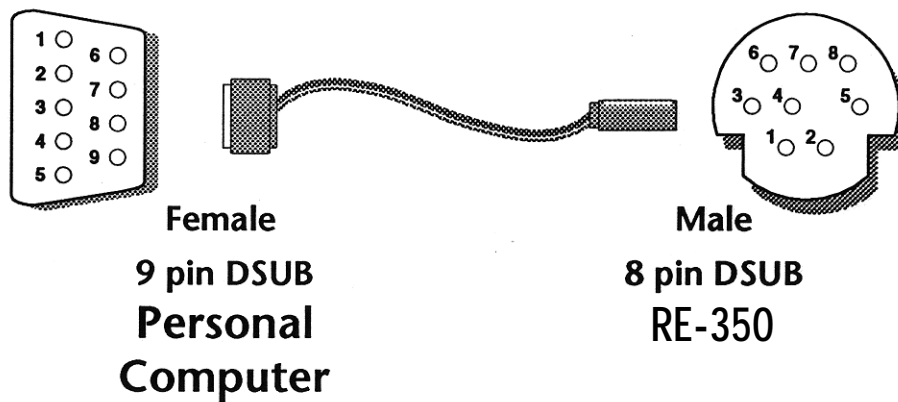

RE-350 Control Cable Pin Assignments RS-232C for Macintosh™ Computers

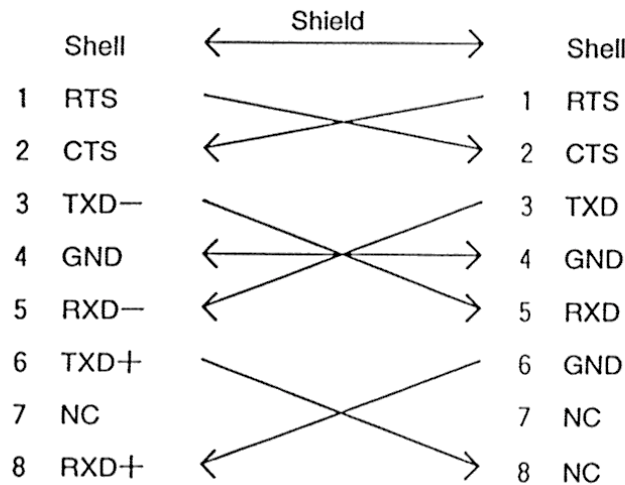
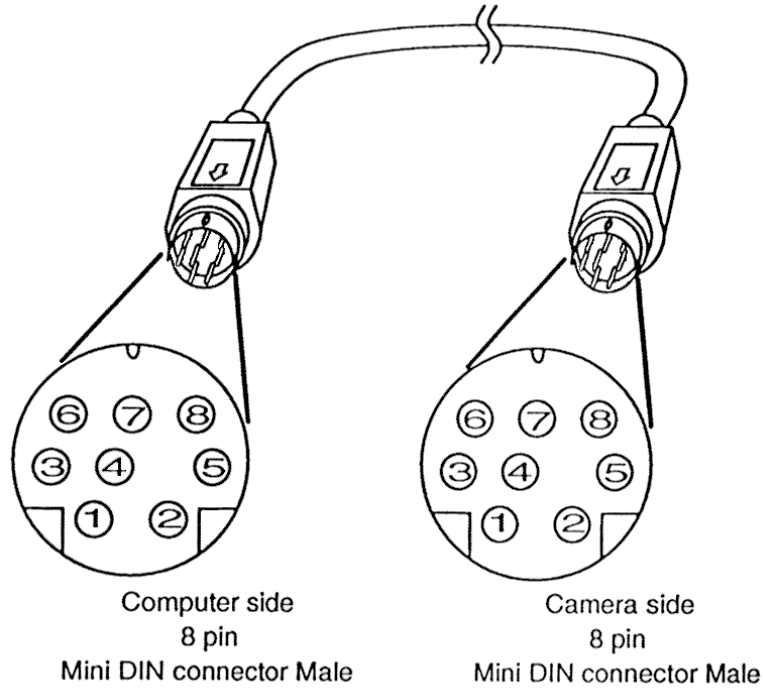

Note: RS-232C Specification allows cable length up to 15m, but it should be kept as short as possible.

The following cables which have the above connections can be used:

Apple	System Peripheral 8	1.0m
InMac	74415 (for Image Writer II)	1.8m

6.0 Timing Charts

6.1 RTS/CTS Flow Control Timing Chart

PC SIDE SIGNAL

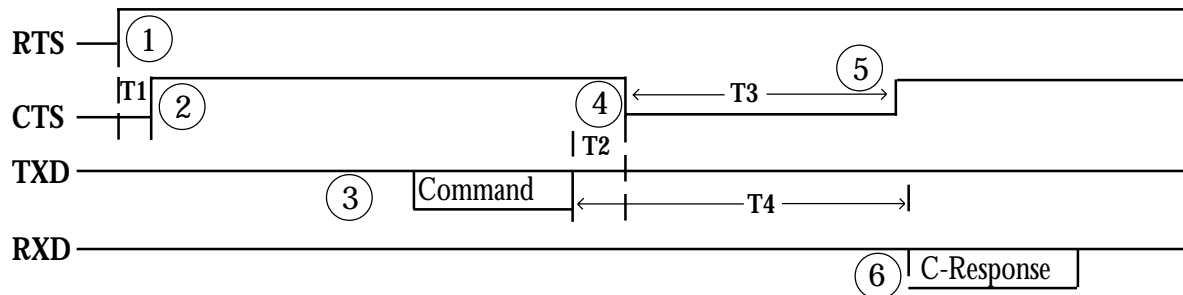

Mark	Duration period	
	Min.	Max.
T1	-	300ms
T2	0ms	200ms
T3	10ms	T4-T2
T4	10ms	*1

- ① If the PC is ready to communicate with the RE-350, the PC should set the RTS line to ON. The RE-350 will recognize that its RS-232C connector is connected to the PC. When the RTS is OFF and the PC tries to send some data, the RE-350 will disregard the sent data.
- ② Once the RE-350 recognizes that the RTS of the PC is ON, the RE-350 will set the CTS of the PC to ON within T1 after RTS is ON. The application software on the PC can recognize if the RE-350 is operating properly.
- ③ After the PC recognizes the CTS is ON, the PC can send the command packet to the RE-350.
- ④ Once the RE-350 receives the command packet, the RE-350 will set CTS to OFF and perform the operation depending upon the command data from the PC to tell the PC that the RE-350 cannot receive another command packet during this period.
- ⑤ After finishing the operation, the RE-350 will set CTS to ON to tell the PC that the RE-350 can receive another command packet.
- ⑥ At the same time, the RE-350 will send the “C-response Packet” to notice the result of its operation. The period (T4) between the reception and transmission of the “C-response Packet” is determined by the type of command given.

Note: If the RE-350 does not follow the above timing chart, the power or connection of the I/F cable is incorrect.

6.2 RTS flow control timing chart

The PC can suspend the transmission of the “C-response Packet” data for the period less than 1000 milliseconds from the RE-350 by setting the RTS signal to OFF.

PC SIDE SIGNAL

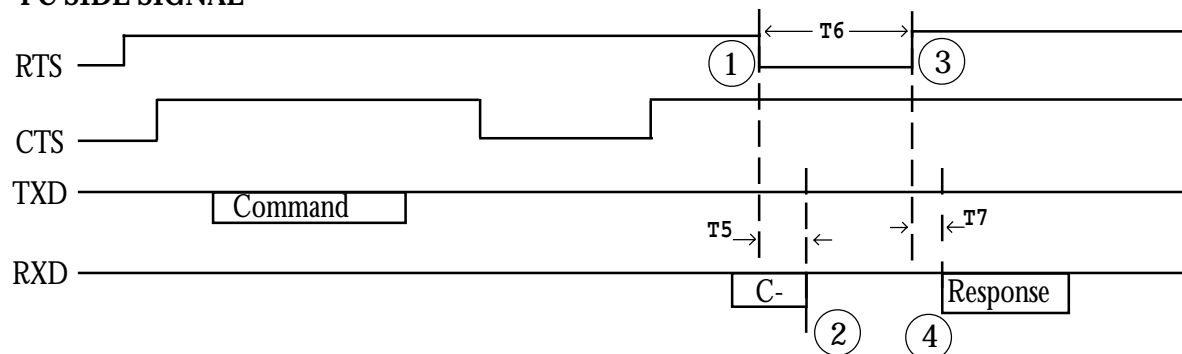

Mark	Duration period	
	Min.	Max.
T5 (9600bps)	3.44ms	300ms
(2400bps)	4.58ms	300ms
T6	--	1000ms
T7	--	200ms

- ① If the PC wants to suspend the transmission of the “C-response Packet” data stream on its half, the PC should set the RTS line to OFF.
- ② Once the RE-350 recognizes the RTS of the PC is OFF, the RE-350 will hold the transmission of the “C-response Packet” data after the remaining maximum 3 byte data in its communication buffer is transmitted. The application software on the PC can recognize if the RE-350 is operating properly. The time period required for transmitting the remaining data in the buffer will depend upon the communication speed of the RS232C I/F.
- ③ When the PC wants to resume the transmission, the PC should set RTS to ON immediately. The longest time period to be able to hold the transmission is 1000 milliseconds. If the PC fails to set the RTS line to ON in 1000 milliseconds, the RE-350 will stop the sequence to send the “C-response Packet”. The PC can not receive the remaining C-response data any more.
- ④ Once the RE-350 recognizes the RTS signal comes back to ON within 1000 milliseconds, the RE-350 will resume the transmission of the “C-response Packet” data.

Appendix A – Disk Information

RE-350 Software Developer's Disk Installation

Description:

This disk contains one auto-extracting compressed file which once uncompressed contains 3 separate directories. The 3 directories are APP, 16BITS SDK, and 32BITS SDK. Within the APP directory is a Demo Application that was created using the documentation and example data files in this SDK. The 16BITS SDK and 32BITS SDK directories contain .DLL and Example application files for programming in a 16bit or 32bit environment.

How to Install the Compressed File From MS-DOS:

1. Create a directory named "RE350" on your hard drive. Copy the contents of the RE-350 Software Developer's Disk into that directory.

2. From the RE350 directory, type "RE350SDK.EXE -d" at the "C:\RE350>" DOS prompt.

*** Make sure you use the -d option so that separate directories are created when the file is expanded. ***

Running this .exe file will create 3 directories, a 16BITS SDK directory, a 32BITS SDK directory and an APP directory within the RE350 directory. See the following pages for a description of their individual contents.

How to Install the Compressed File From Windows:

1. Create a folder named "RE350" on your hard drive. Copy the contents of the RE-350 Software Developer's Disk into that folder.

2. Using the Run command under the START button (Win95) OR the Run... command under the File menu in the Program Manager (Win3.1), type "C:\RE350\RE350SDK.EXE -d" in the "Open:" text field box.

*** Make sure you use the -d option so that separate directories are created when the file is expanded. ***

Running this .exe file will create 3 directories, a 16BITS SDK directory, a 32BITS SDK directory and an APP directory within the RE350 directory. See the following pages for a description of their individual contents.

RE-350 Demo Application (\APP)

How to Use the Demo Application:

The RE-350 Demo Application is a 16bit application that runs under Windows 95 and Windows 3.1.

1. Connect the RE-350 to the computer. Using a correctly pinned RS-232 cable (pp.57-59) connect one end to the RS-232C output on the RE-350 and connect the other end to an available COM port on your computer.
2. Turn on the RE-350 and the computer and launch Windows.
3. In the APP directory that was created from the SDK disk is a file named CTL3DV2.DLL. This file should be placed into your System folder within Windows [c:\Windows\System].
4. Double click on the RE-350 Demo Application icon in the APP directory.

When the application has successfully launched, the On-Line LED should be lit on the RE-350's front control panel and within the GUI of the software interface.

Very simply the RE-350 Demo Application offers remote operation of all manual buttons and control knobs located on the front control panel via the RE-350 graphical user interface.

If the Application Does Not Launch Properly Check:

- COM Port Setting – The COM port setting selection in the RE-350 Demo Application should match the COM port the RE-350 is connected to on the computer.
- ID Setting – The ID Setting on the rear panel of the RE-350 (p.3) should match the ID Setting the RE-350 is set to.
- Baud Rate – The Baud Rate setting selection in the RE-350 Demo Application should match the baud rate selected via the switch on the rear panel of the RE-350 (p.3).
- Cable – Make sure you are using a correctly pinned cable. Check with the pin out diagram on pp.57-59.

RE-350 SDK File Definitions

re350.c	RE-350 communications driver.
re350.h	Driver definitions.
re350.obj	Object file.
re350dll.dll	Dynamic Link Library.
re350dll.mak	Microsoft C/C++ Version 1.52 Project (NMAKE)
example.c	Sample Windows application.
example.obj	Object file
example.exe	Executable Windows Application
example.def	Module definition file.
example.mak	Microsoft C/C++ Version 1.52 Project (NMAKE)
readme.doc	This file.

RE-350 16bit Sample Code (\16BITSDK)

Notes:

- 1) This example application was written and compiled with Microsoft C/C++ and SDK Version 1.52 (16 bits ONLY).
Open the project in Microsoft Visual C/C++ to edit and recompile.

The DLL and example application are built separately. You can use RE350DLL.DLL as is by importing the functions described below (or in RE350.H).

You can also rebuild the application in MS-DOS by typing:

```
nmake -fre350dll.mak  
nmake -fexample.mak
```

- 2) RE350.C and RE350.H constitute the basic driver and are generalized to work with any application. All of the functions return an error code (defined in RE350.H) to indicate whether the operation was successful.

Initialize communications with the RE-350:

```
int FAR PASCAL      RE350_Open( int iComPort )  
    int iComPort:    RE350_COM1-RE350_COM4
```

Execute an RE-350 command:

```
int FAR PASCAL      RE350_Command( int iDevice, int nCmd, WORD wRequest, LPWORD lpwResponse );  
    int iDevice:     device 0-3 (check dip switch on the back)  
    int nCmd:        Command defined in RE350.H.  
    WORD wRequest:   Request data if required by command.  
                    (Use RE350_NULL_REQUEST if not required).  
    LPWORD wRequest: Pointer to response (or NULL).
```

Close communications with the RE-350:

```
VOID FAR PASCAL     RE350_Close( VOID );
```

- 4) EXAMPLE.C is a simple application which demonstrates the operation of the driver. After getting this to compile in your environment, you can add additional commands (via RE350_Command) to test the camera's operation. All of the RE-350 commands are implemented through this function.

RE-350 32bit Sample Code (\32BITS SDK)

Notes:

- 1) This example application was written and compiled with Microsoft C/C++ and SDK Version 4.0 (32 bits ONLY). Open the project in Microsoft Visual C/C++ 4.0 to edit and recompile.
- 2) The RE-350 driver (RE350.DLL) is located in .\EXAMPLE\RE350 and has been setup as a sub-project of EXAMPLE. It will be automatically updated if EXAMPLE is set as the project. The output is directed to the EXAMPLE\RELEASE directory so any changes made to the DLL will be automatically loaded by the application next time it is run. EXAMPLE explicitly loads and unloads the DLL using LoadLibrary() and FreeLibrary() to facilitate this (see EXAMPLE.C).
- 3) RE350.C and RE350.H constitute the basic driver and are generalized to work with any application. All of the functions return an error code (defined in RE350.H) to indicate whether the operation was successful.

Initialize communications with the RE-350:

```
int FAR PASCAL      RE350_Open( int iComPort )
    int iComPort:    RE350_COM1-RE350_COM4
```

Execute an RE-350 command:

```
int FAR PASCAL      RE350_Command( int iDevice, int nCmd, WORD wRequest, LPWORD lpwResponse );
    int iDevice:     device 0-3 (check dipswitch on the back)
    int nCmd:        Command defined in RE350.H.
    WORD wRequest:   Request data if required by command.
                    (Use RE350_NULL_REQUEST if not required).
    LPWORD wRequest: Pointer to response (or NULL).
```

Close communications with the RE-350:

```
VOID FAR PASCAL     RE350_Close( VOID );
```

- 4) EXAMPLE.C is a simple application which demonstrates the operation of the driver. After getting this to compile in your environment, you can add additional commands (via RE350_Command) to test the camera's operation. All of the RE-350 commands are implemented through this function.

This product is provided AS IS. For questions regarding product operation contact Canon Information Technology Services at 1-800-828-4040

All rights are reserved. No part of this document may be photocopied, reproduced, translated to another language, stored in a retrieval system, or transmitted in any form without the prior written consent of Canon U.S.A., Inc.

The information contained in this document is subject to change without notice. Canon U.S.A., Inc. makes no warranty of any kind with regard to this written material. Canon U.S.A., Inc. assumes no responsibility for any errors that may appear in this document or for incidental or consequential damages in connection with the furnishing, performance or use of this manual.

Canon is a registered trademark of Canon, Inc. ©1996 Canon U.S.A., Inc. 11.13.96
All trademarks and registered trademarks are the property of their respective owners.

Free Manuals Download Website

<http://myh66.com>

<http://usermanuals.us>

<http://www.somanuals.com>

<http://www.4manuals.cc>

<http://www.manual-lib.com>

<http://www.404manual.com>

<http://www.luxmanual.com>

<http://aubethermostatmanual.com>

Golf course search by state

<http://golfingnear.com>

Email search by domain

<http://emailbydomain.com>

Auto manuals search

<http://auto.somanuals.com>

TV manuals search

<http://tv.somanuals.com>