

BTM RACING

DB10R

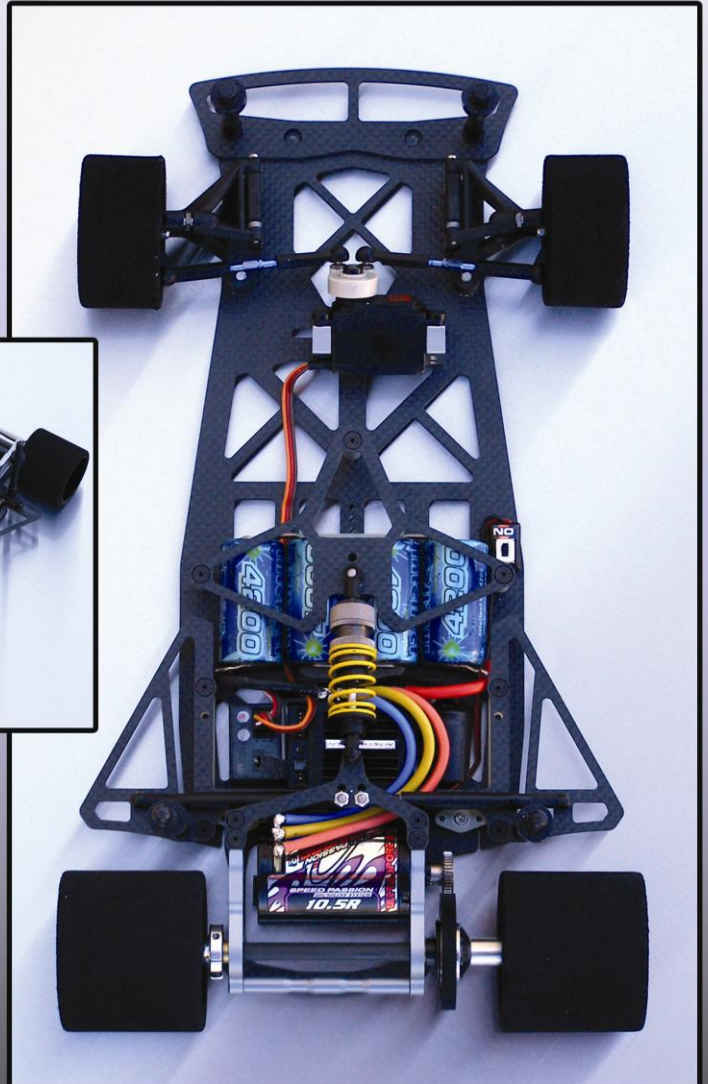
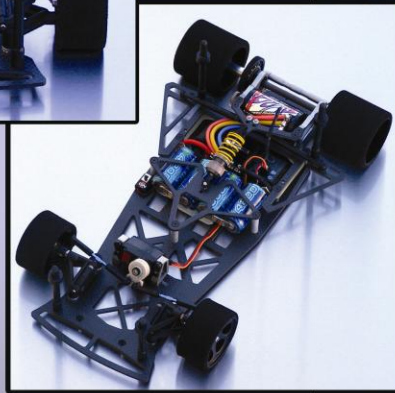
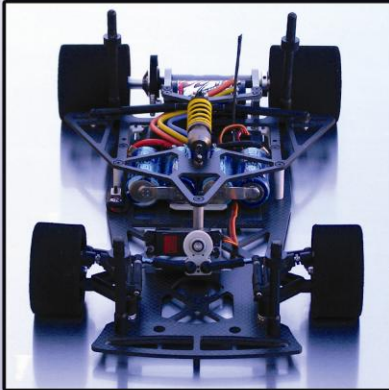

"The design goal of the DB10R program was to create the most advanced Pro-10 car ever. No compromises, no short cuts, no mercy for the competition"

Jason Breiner

ASSEMBLY MANUAL

Version 1.00 3-25-2008

Download from www.Somanuals.com. All Manuals Search And Download.

Message from BMI Racing

Pro-10 is poised to make a return as a popular racing class, with racers tiring of the costs, complexity and steep learning curve associated with 4wd sedans this new class is an inexpensive, fast and simple way to enjoy racing again. BMI Racing's R&D team have been working to develop a state of the art Pro-10 car that is far beyond the old technology of 235mm pan cars, the result of this program is the new DB10R.

Based on our ultra successful DB12R 1/12th scale racer the DB10R is a revolutionary leap in the development of Pro-10 chassis. Featuring BMI Racing Flex Link rear suspension system and our innovative "Center Mass" chassis layout the DB10R is set to dominate at any track on any surface.

The "Center Mass" chassis layout places all of the chassis components in the correct location to yield a perfect left to right balance and front to rear weight distribution. The revolutionary feature of the DB10R's "Center Mass" chassis is the placement of the speed control and receiver in the center of the chassis behind the battery. This has three very critical benefits. Dealing with the battery and electronics as a unit allows us to better control the weight distribution for superior feel and handling characteristics. A brushless speed control is relatively heavy. If it is offset to one side or another of a central battery, weight must be added to counter balance it. The weight of a micro receiver on the other side of the chassis is not enough to balance the chassis. Another important benefit of a rear mounted speed control is very short power wires for lower voltage losses and very tidy wiring leading to the receiver.

The DB10R follows the new 200mm spec for Pro-10 cars. This size chassis allows racers to use a large variety of bodies from Nitro Sedans to GT, Super Car and Vintage Muscle car bodies. More realistic bodies are one of the keys to the successful return of the Pro-10 class.

Please read through the instruction manual carefully. Even if you are an experienced R/C racer, there are some details about the DB10R that are different. To get the most out of your kit you must have it assembled correctly.

With Regards,

Jason Breiner

BMI Racing

Items needed to assemble your DB10R

1. .050", 1/16" and 3/32" Allen wrenches
2. A #2 Phillips Screwdriver
3. 3/16" and 11/32" nut drivers
4. A pair of needle nose pliers
5. A pair of slip joint pliers
6. A hobby knife
7. A ruler or calipers
8. A file
9. A soldering iron
10. Diff Grease
11. Electric Motor Cleaner Spray
12. 40wt silicon shock oil (for center shock)
13. 10,000wt silicon diff oil (for damper tubes)

Items needed to operate your DB10T

1. Two channel surface Radio system
2. A servo*
3. One or more 4 cell battery packs
4. A battery charger
5. An electronic speed control
6. An electric motor
7. A 64 pitch pinion gear
8. A small servo saver.
9. A 200m 1/10th scale body
10. 1/10th foam tires scale tires

* The DB10R was designed to use mini servos. While any servo will fit the ideal weight distribution is best achieved with a min servo such as the Futaba 9602, 3650, JR 3650, etc.

Front suspension assembly



Step 1

Locate your lower front suspension arms and the hard anodized alloy pivot balls. Note that the arms are not symmetrical.

Pop the pivot balls into the arms with the shoulder on the ball facing up. Do this by placing the ball on a hard flat surface and placing the arm over the ball. Carefully push the arm down over the pivot ball. Be careful. It will take a lot of force.

Special Note:

The best way to install the pivot balls is with an IRS pivot ball tool (www.teamirsrc.com, IRS1376). If the pivot balls are tight you can over tighten this tool, after the ball snaps in, a little at a time until the ball moves freely.

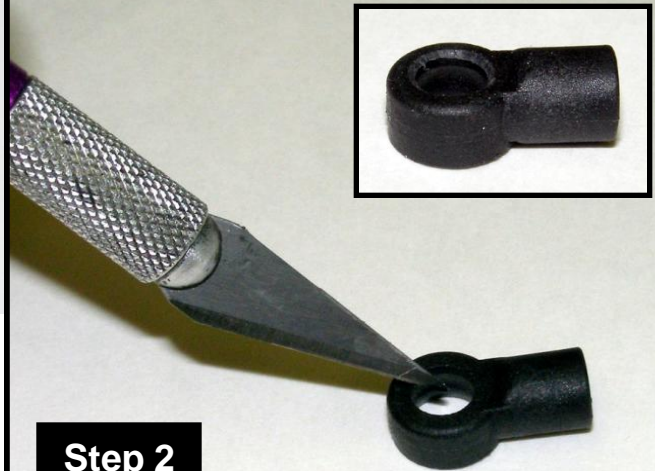

Step 2

Locate your upper suspension arm rod ends. Note that the top side of the rod end opening is smaller than the bottom

With a hobby knife, carefully chamfer the top of the rod ends opening. This creates clearance for the king pin shims that will go here later. This will ensure there is no binding in the suspension.

The inset picture shows a finished rod end.



Step 3

Locate the two remaining hard anodized alloy pivot balls and snap them into the upper arm rod ends with the shoulder on the ball facing down. As with the lower arms, squeeze the rod ends if the balls do not move freely.



Step 4

Locate the upper suspension arms, the upper arm turnbuckles and assemble as shown above.

We prefer to thread the right hand thread portions of the turnbuckles into the rod ends and the left hand thread into the upper arms.

Note:

The arms have a bottom and a top. They have small circular impressions on the bottoms.



Step 5

Locate the 10 degree reactive caster upper suspension mounts, upper suspension hinge pin, e-clip and nylon caster spacers.

Assemble as shown.

Make sure the upper suspension arms pivots freely. If there is any binding at all, the car may handle poorly. If the upper arms are tight, use the back of a hobby knife to scrape the front and back of the reactive caster blocks and the inside of the upper suspension arms to make more clearance for the caster spacers. Take your time here and get it right!

Special Note:

The DB10R uses IRS upper hinge pins and does not require setscrews in the upper suspension arm mounts.

Step 6

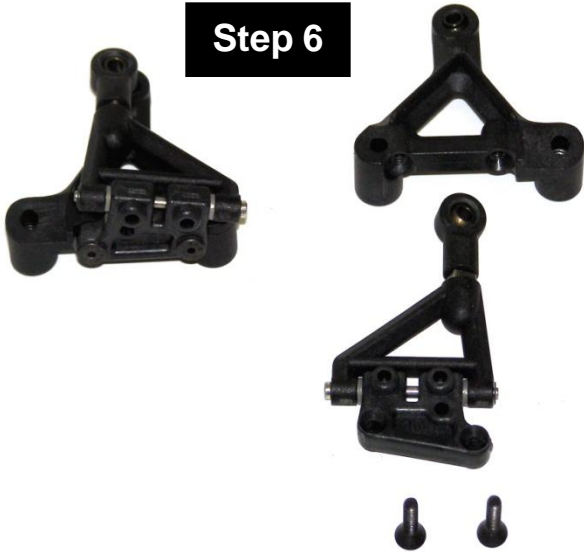

Attach the upper suspension arm assembly to the lower suspension arms as shown with 4-40 x 1/2" screws.

Step 7



Locate the Ti front axles, four 4-40 alloy lock nuts, and two alloy pivot balls.

Thread the Ti axles into the steering spindles. Note that the threads on the axles that go into the spindles are left hand. After the axles are fully seated tighten an alloy 4-40 lock nut onto the threaded stub coming out the back of the spindle.

Thread the alloy pivot balls into the holes on the steering arms and secure them with alloy 4-40 lock nuts. Remember these are alloy pivot balls so make the nuts snug. They are strong enough to last a few racing seasons; but if you crank them down, you can snap them.

Step 8

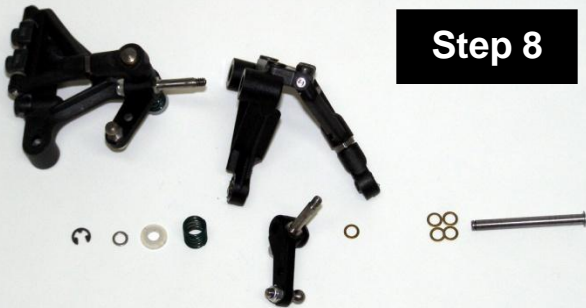

Locate 2 steel 1/8" king pins, 12 1/8" shims, 2 e-clips and 2 .022" king pin springs and 2 white nylon spring perches.

1. Slide 4 shims onto the king pins against the capped end of the king pin.
2. Pass this through the pivot ball in the upper suspension arms rod end.
3. Place one more shim on the king pin.
4. Slide the steering spindle onto the king pin.
5. Slide the king pin through the pivot ball in the lower suspension arm.

7. Slide the spring onto the king pin.
8. Place a nylon spring perch and one 1/8" shim onto the king pin then snap an e-clip on to the bottom of the king pin.
9. Repeat for the other side of the front suspension.

Special notes:

Make sure the steering arms on the spindle are pointing towards the rear of the car as shown in the picture.

The axle is offset in the spindle. Make sure the axle is closest to the lower suspension arm. As shown in the picture to the left

It is important that the king pin slide freely in all of the parts including the steering spindle. When you thread the axle into the spindle, it may swell the king pin bore and make it tight on the spindle. You can try to use a 1/8" drill to open it up but the best solution is to use a 1/8" reamer.

You can order the reamer from:
www.mcmaster.com. The part number is [2995A61](http://www.mcmaster.com)

Step 9

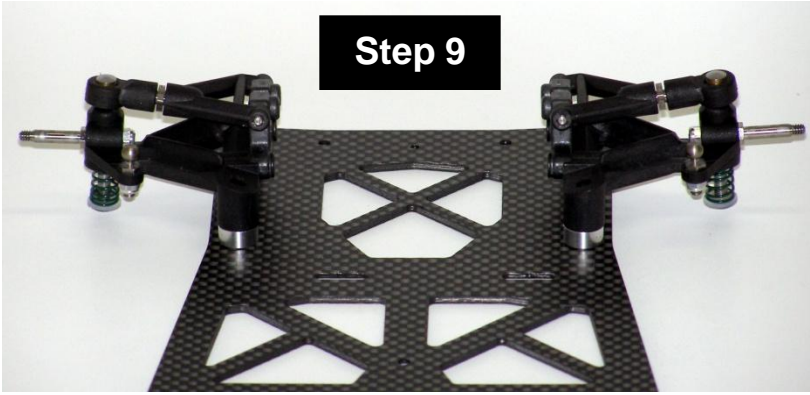

Locate four 8-32 x 5/8" screws and 4 thin and 4 thick nylon lower suspension arm risers.

Pass a screw through the chassis and slide a thin and a thick nylon riser over the screw. Start threading the screw into the lower suspension arm but do not tighten it. Pass another screw through the chassis and slide a thin and a thick nylon riser over that screw. Start threading the screw into the other hole on the lower suspension arm. Tighten both screws. Repeat on the other side.

Special Note:

In the photo we are using alloy ride height spacers. The kit includes black nylon spacers. You will have to add or subtract spacers in order to achieve your desired ride height. If you want to use the alloy spacers you can get a variety of sizes from www.bmiracing.com, (P/N DB5311-DB5316)

Rear suspension assembly

Step 10

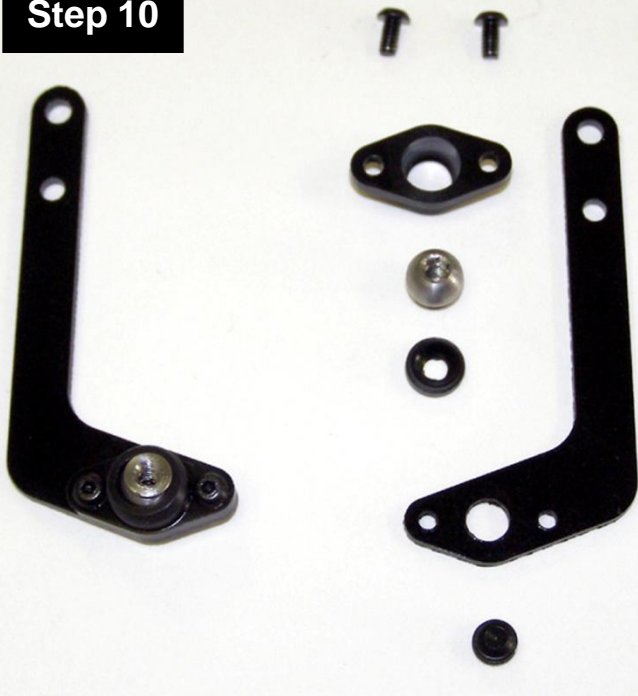

Locate two flex plates*, 2 Nickel Teflon plated Alloy pivot balls, 2 delrin pivot ball housings, 2 delrin housing caps, 2 10-32 set screws* and 4 2-56 button head screws.

1. Place a pivot ball in a pivot ball housing with the shoulder on the ball facing down.
2. Place a housing cap over the ball.
3. Place the flex plate over this assembly.
4. Pass the 2-56 screws through the pivot ball housing from the bottom up so they thread into the flex plate.
5. Thread 10-32 set screw into the large hole on the flex plate above the housing cap. Just get the 10-32 started into the flex plate for now as we will adjust it later.

The 10-32 set screw is there to adjust tension on the pivot ball so it can move freely but have zero play.

*Black flex plates and 10-32 set screws were used for photos. The production links are natural G10 in color and the production screws are stainless steel.

Step 11

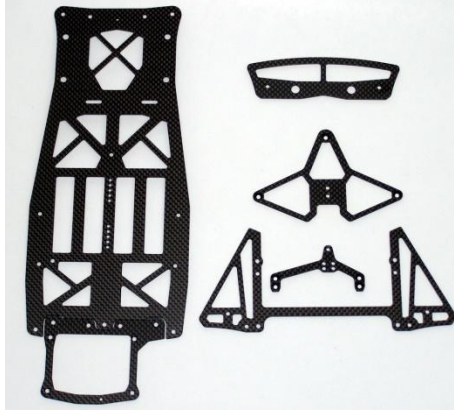

Take a minute to prepare all your carbon components for assembly. With a file or sand paper knock off any sharp edges along the perimeter or the carbon parts.

The cell slots in the chassis are designed to fit the cells properly if you just knock off the sharp edges. If you bevel the cell slots the batteries will hang below the bottom of the chassis.

Special note:

Carbon fiber dust is really bad for you. Always wear a mask and eye protection when sanding or filing carbon fiber.

Step 12

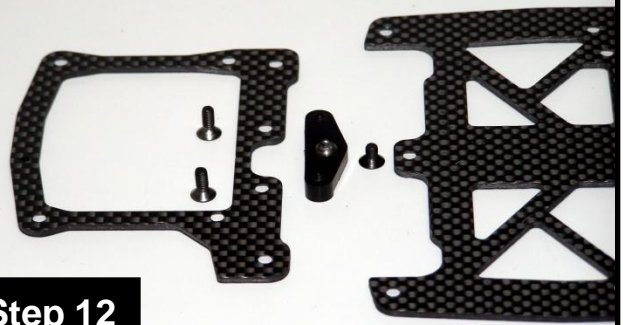

Locate the delrin center pivot assembly one 4-40 x $\frac{1}{4}$ " and two 4-40 x $\frac{3}{8}$ " flat head screws.

Attach the center pivot assembly to the rear most hole in the center of the lower chassis plate with the $\frac{1}{4}$ " screw. The shoulder on the pivot ball and the two bosses on the center pivot assembly should face down towards the chassis. The pivot ball has a $\frac{3}{32}$ " hex in the top so you can use a wrench to tighten it firmly.

Attach the rear lower pod plate to the center pivot assembly with two 4-40 x $\frac{3}{8}$ " flat head screws.

Step 13

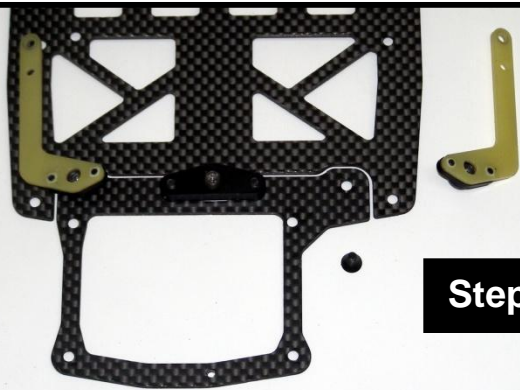

Attach the two flex plate assemblies to the rear lower pod plate with 4-40 x 1-4: flat head screws.

Temporarily remove the 10-32 set screws in the flex plates in order to access the $\frac{3}{32}$ " hex in the top of the pivot ball so you can tighten it down firmly.

Replace the 10-32 set screw and adjust it so there is no play between the pivot ball and the pivot ball housing on the flex plate. However, the flex plate must still move freely. If you lift the front of the flex plate, it should fall under its own weight when you let it go.

Step 14

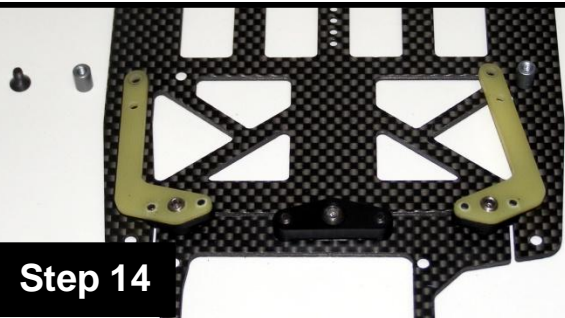

Locate 2 gray anodized non-threaded spacers, 2 gray anodized threaded spacers and 2 4-40 x $\frac{1}{4}$ " flat head screws.

1. Pass a 4-40 x $\frac{1}{4}$ " flat head screw through the hole in the chassis corresponding to the front hole on the flex plate.

2. Thread the gray threaded spacer onto the screw and hold it with needle nose pliers as you tighten the screw.

3. Repeat to assemble the other side

Step 15

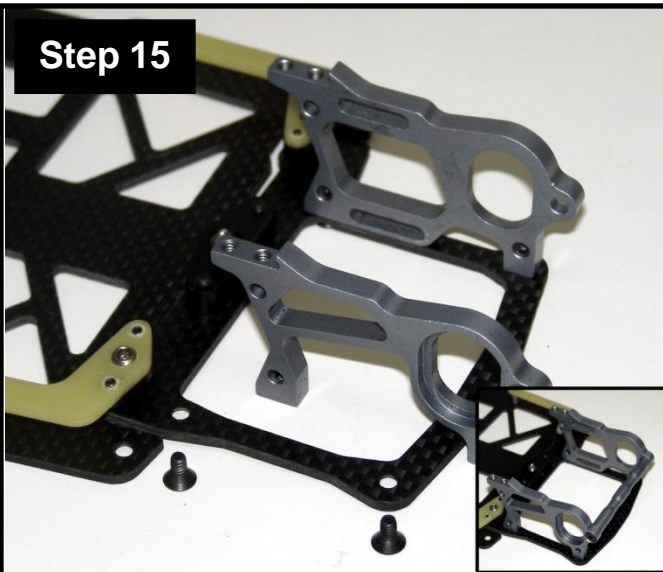

Locate the two alloy rear pod plates, the alloy rear pod plate spacer tube 2 4-40 x 3/8" flat head screws and 4 4-40 x 1/4" flat head screws.

Attach the alloy pod plates to the lower carbon pod plate with the 4 4-40 x 1/4" screws.

Attach the alloy rear pod plate spacer tube to the alloy rear pods with the 2 4-40 x 3/8" screws.

Step 16



Locate and install the two long gray anodized threaded spacers as shown with 4-40 x 1/4" flat head screws

Step 17

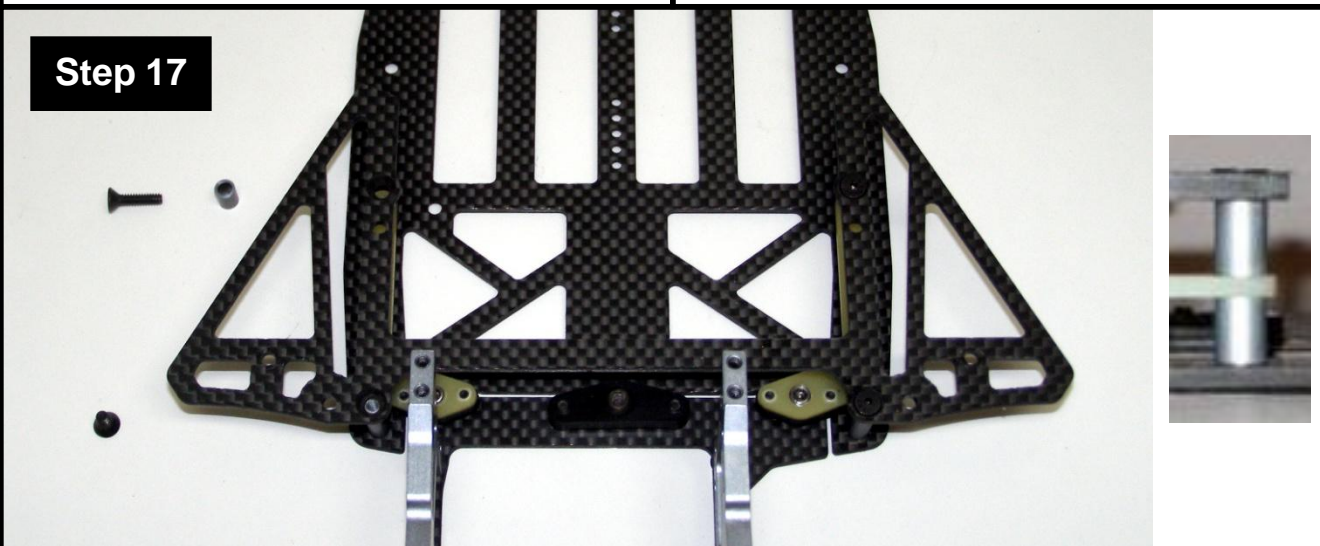

Locate 2 4-40 x 1/4" flat head screws, 2 4-40 x 1/2" flat head screws and 2 gray alloy unthreaded spacers.

1. Attach the carbon chassis brace to the chassis with 2 4-40 x 1/4" flat head screws by threading them into the long gray alloy threaded posts at the rear corners of the chassis.
2. Pass a 4-40 x 1/2" flat head screw through the countersunk hole at the front of a chassis brace wing. Slide an alloy gray unthreaded spacer under the carbon chassis brace and pass the 4-40 x 1/2" flat head screw through it.
3. Move the flex plate under the 4-40 x 1/2" flat head screw so the screw passes through the front hole in the flex plate and finally into the gray alloy threaded spacer you put in the chassis in Step 14. Check out the small detail photo to check you assembly.

Step 18



Locate the damper tube parts bag, the rear pod top plate and 4 4-40 x 1/4" flat head screws..

1. Thread a 4-40 x 1/2" set screw into each of the 4 ball cups from the damper parts bag.
2. Thread a ball cup/set screw assembly into the ends of each of the damper tube pistons and damper tubes.

3. Apply 10000wt silicon diff oil to the pistons and insert them into the damper tubes.
4. Attach the alloy pivot balls to the bottom of the pod top plate and the tops of the side wings as shown above. Secure them with alloy lock nuts
5. Attach a black medium ball stud on top of the top pod plate in the front and center hole. Secure it with an alloy lock nut.
6. Attach the carbon pod top plate to the alloy rear pod plates
7. Snap the ball cups of the assembled damper tubes onto the pivot balls on the pod top plate and wings.

Note:

If you feel play between your ball cups and ball studs, you can place a single layer of plastic bag material between your ball cup and ball stud then snap them together. This will cut and insert a disc of plastic into your ball cup reducing or eliminating the play. If you still feel play, repeat the process.

Step 19

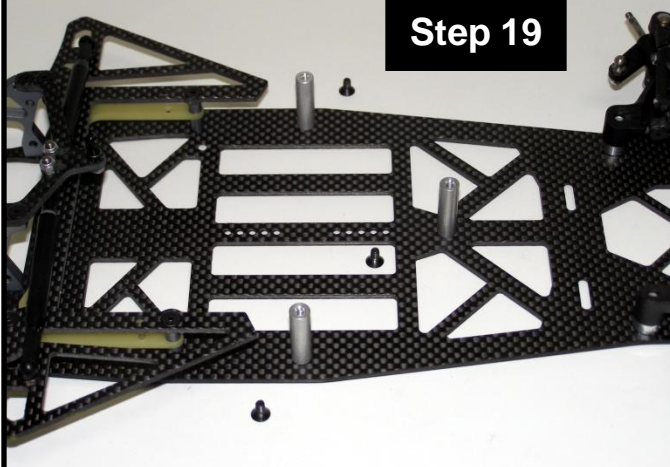

Attach 3 7/8" alloy stand offs to the chassis in the locations shown with 4-40 x 1/4" flat head screws.

Note:

The production stand offs will be black in color not silver as on the prototype used for these photos.

Step 20



Install a short ball stud in the battery retention plate in the hole show in the picture above. Secure it with an alloy lock nut.

Step 21

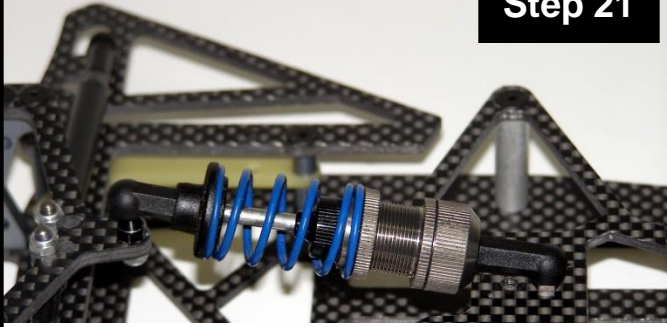

1. Attach the battery retention plate to the 3 alloy stand offs with 3 4-40 x 1/4" flat head screws.
2. Assemble the IRS Nickel-Teflon Macro Shock as per the included instructions with 40wt silicon shock oil.
3. Install the included center shock spring onto the shock and snap the shock in place.

Trim both of the ball cups that thread onto the ends of the shock to .630" (16mm) in length. Thread the ball cups on the ends of the shock so the over all shock length is 3.11" (79mm). This length will give you the standard setting of 1.5mm of rear pod droop.

Note:

The spring in the production kit may not be blue.

Step 22



Locate the rear axle parts bag. There are a couple of steps that can make your diff last longer that should be done at this time.

Use the right alloy diff hub as a holder and sand both sides of each diff ring on 600 grit sand paper using electric motor cleaner spray as a lubricant. Sand until you see an even scoring pattern across the face of each diff ring. Clean them with motor spray and set them aside.

The diff balls may have a protective oil coating on them. Place them on a clean paper towel and carefully clean them with motor spray. When dry drop them into your cup of diff grease and stir them to coat them with diff grease.

Diff Assembly:

Step 22 Continued

1. Put a small dab of diff grease on the axle flange so the diff will stick to it. Place a diff ring on the flange so its flat keys onto the flat on the diff flange.
2. Place a flanged 3/8 x 1/4" bearing in the center of the spur gear. Slide the spur gear and bearing unit on to the axle until it stops against the diff ring.
3. With a small flat screw driver remove the diff balls from the diff grease and snap them into the outer row of holes in the spur gear.
4. Place a flanged 3/8 x 1/4" bearing into the inside face of the right side diff hub. Put a small dab of diff grease on the hub flange so the diff will stick to it. Place a diff ring on the flange so its flat keys onto the flat on the hub flange. Slide this unit on to axle.
5. Slide a flanged 3/8 x 1/4" bearing over the axle into the outside face of the right side diff hub. Slide the stepped thrust cone onto the axles so the smaller diameter part is against the right hub bearing.
6. Thread the black nylon lock nut onto the threaded stud on the axles until it makes contact with the thrust cone.
7. Tighten the black lock nut gradually with an 11/32" nut driver until you notice you cannot slip the spur gear when holding the axle and right hub in a fixed position.

Six 4-40 x 1/4" cap head screws are supplied to mount your rear wheels.

Notes:

Keep you fingers clean with motor spray. Diff assembly is like surgery. You do not want dirt or oil where it does not belong.

The grease on the diff balls when you pluck them out of the cup of diff grease is all you need. Smearing diff grease on the rings will make your diff get dirty faster and make a mess.

The ultimate goal in building a diff is one which is extremely free and glass smooth but requires a lot of force to slip the spur gear.

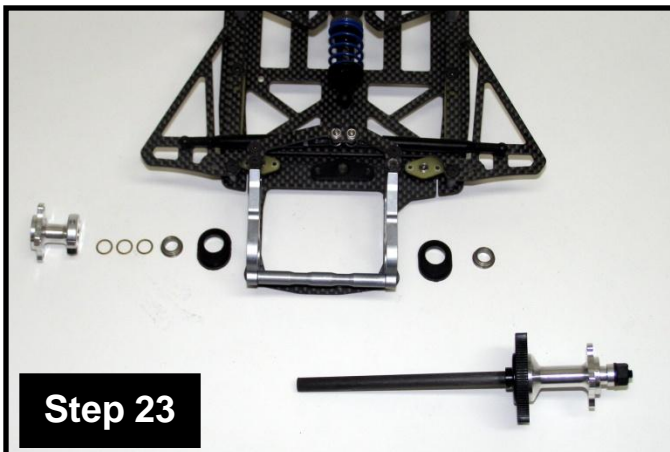

Step 23

Insert the IRS precision ride height adjuster cams into the rear alloy pod plates. Insert a 3/8" x 1/4" flanged bearing into each ride height adjuster and insert the axle as shown. Install your favorite wheels and measure the width of the car. Shim as necessary to obtain a centered axle and a 200mm rear track width.

Special Note:
The DB10R is designed to work with IRS precision ride height adjuster cams. We find too much size variation in other cams and cannot guarantee they will fit properly.

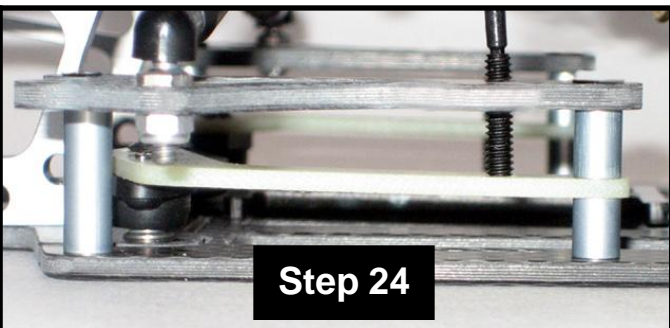

Step 24

Install a 4-40 x 1/2" set screw into each flex plate.

Special note:
While these long set screws were initially designed to be tweak screws in testing we found the nature of the rear suspension system never lets the car get tweaked.

Now, the set screws in the flex plates function as roll stiffeners. If you want less roll in the rear of your car, you can run them down so they just touch the top of the lower chassis.

Under most conditions we run them so they are not touching, or we do not install them at all.

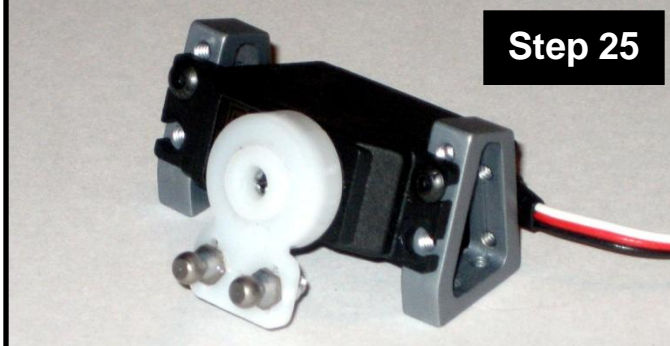

Step 25

Angled Mounting

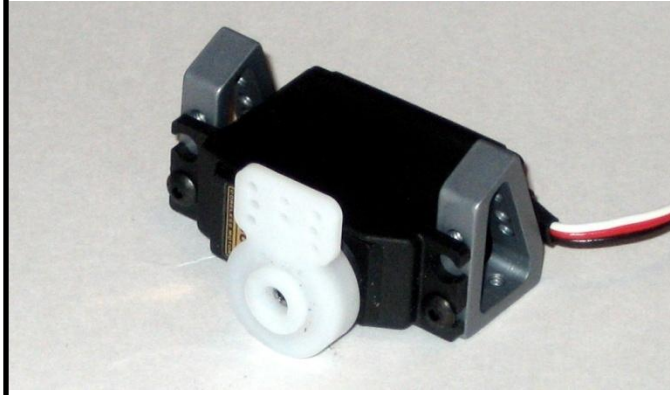

Flat Mounting

You have two servo mounting options with the DB10R, Angled or Flat. The new BMI Servo Mounts have holes to allow either mounting option.

The Reactive Caster front suspension used on the DB10R is designed to function best with angled servo mounting. The hardware supplied with this kit is what you need for angled mounting.

If you wish to mount your servo flat, you will need two long off set ball studs to replace the standard offset ball studs on your steering spindles. These ball studs will correct the steering geometry and eliminate the bump steer present if you did not use them.

The servo is mounted to the servo mounts with two 4-40 x 1/4" button head screws.

Step 27

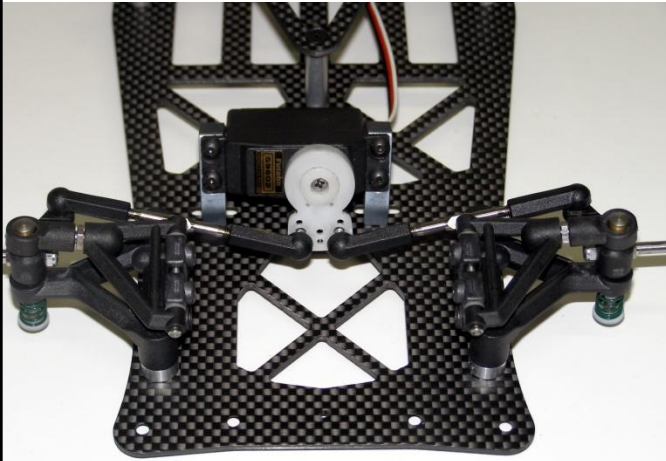

The Servo mounts are attached to the lower chassis with two 4-40 x 1/4" flat head screws.

At this time drill out the center holes on your servo saver (not supplied) for two Nickel Teflon ball studs. Secure them with two 3/16 alloy lock nuts.

Locate two titanium turnbuckles and four black ball cups. Assemble them as shown and adjust them to an over all length of 2.66" (67.5mm). This is a starting point. You will need to reset their length after setting your camber in order to achieve the desired amount of front toe.

Note:

You can use the same plastic bag trick mentioned in Step 18 to remove play in your steering linkage. Remember you want to remove play but still have totally free movement in the links. Any friction at all is unacceptable and will make you car not center properly after steering inputs

Step 28



Install your body posts with two 4-40 x 1/2" flat head screws in the front (the front bumper fits between the lower chassis and the front body mounts) and two 4-40 x 1/4" button head screws in the rear.

Step 29

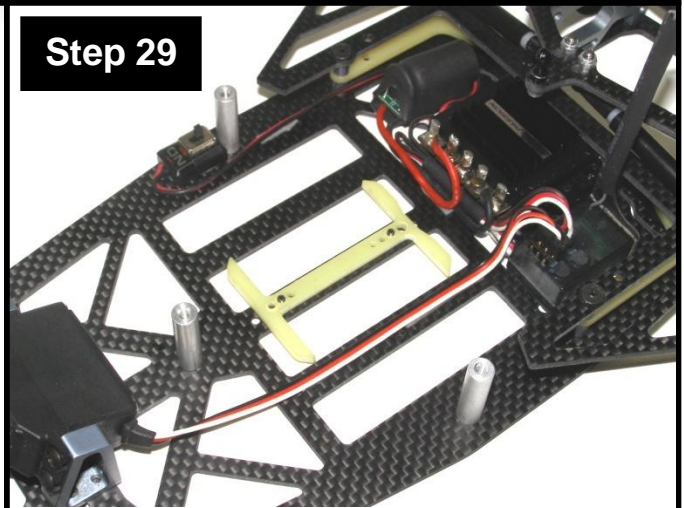

Install the G10 battery locator with 2 2-56 flat head screws. The middle position is a good place to start.

Mounting Electronics (4 cell & Saddle LiPo)

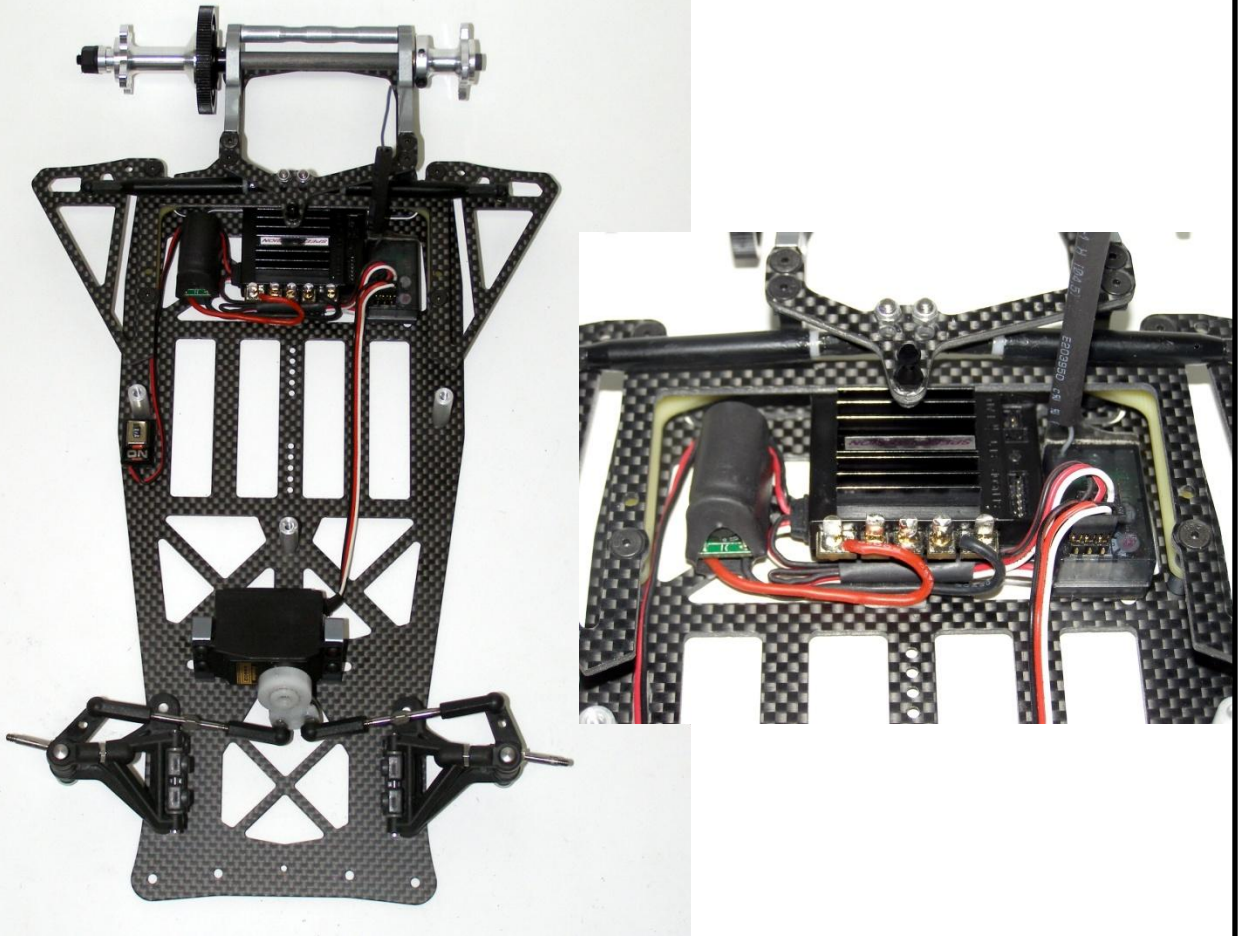

The "Center Mass" chassis layout of the DB10R is one of the features that really puts this car ahead of the pack. This chassis design moves the batteries forward and places the electronics between the battery and the motor pod.

This accomplishes two things.

1. The batteries are moved forward to obtain the proper weight distribution.
2. The electronics are located in the most efficient location (short power wires, tidy receiver wiring).

This lay out is designed to work with 4 cell NiMh cells and LiPo saddle packs such is the Max Amps 4000 Saddle packs (or any LiPo saddle battery that fits in a 72mm(L) x 98mm(W) x 22.2mm(H) area).

Note:

There is an antenna mount hole in the chassis for racers using non 2.4GHz receivers. An antenna mount is not supplied in the kit.

Mounting Electronics (Stick LiPo)

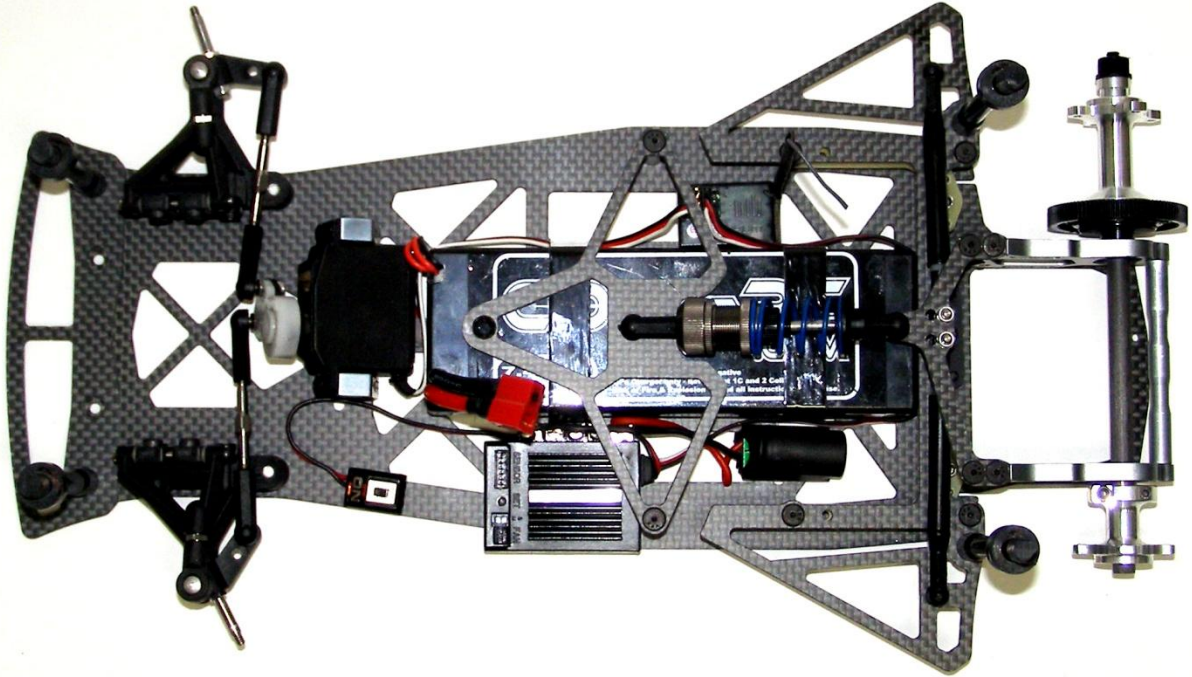

This is the recommended electronics installation when the DB10R is powered by a stick LiPo battery.

You will need to purchase the "Stick LiPo Mounting Kit" (www.bmiracing.com, DB5900) in order to fit the battery. The "Stick LiPo Mounting Kit" consists of 2 longer alloy stand offs that makes room for the taller battery.

Note that this lay out is not ideal as you will need to add weight equal to the weight of your speed control to the right side of the car to balance the weight of the speed control.

Congratulations!

You have completed the assembly of the DB10R Kit.

Please look over the base setup sheet to check your basic setup.

Free Manuals Download Website

<http://myh66.com>

<http://usermanuals.us>

<http://www.somanuals.com>

<http://www.4manuals.cc>

<http://www.manual-lib.com>

<http://www.404manual.com>

<http://www.luxmanual.com>

<http://aubethermostatmanual.com>

Golf course search by state

<http://golfingnear.com>

Email search by domain

<http://emailbydomain.com>

Auto manuals search

<http://auto.somanuals.com>

TV manuals search

<http://tv.somanuals.com>