

**HVC 32 .. - Touch Control  
Vitroceramic Cooking Hob  
Manual for Installation, Use and Maintenance**

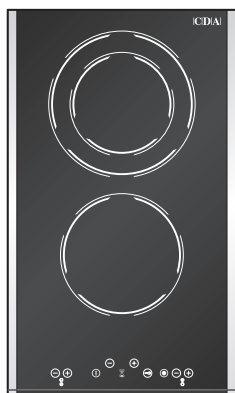

**CDA**

**CE**



## Important

This appliance is designed and manufactured solely for the cooking of domestic (household) food and is not suitable for any non domestic application and therefore should not be used in a commercial environment.

The appliance guarantee will be void if the appliance is used within a non domestic environment i.e. a semi commercial, commercial or communal environment.

The CDA Group Ltd cannot be held responsible for injuries or losses caused by incorrect use or installation of this product. Please note that CDA reserve the right to invalidate the guarantee supplied with this product following incorrect installation or misuse of the appliance.

### Appliance Information:

Please enter the details on the appliance rating plate below for reference, to assist CDA Customer Care in the event of a fault with your appliance and to register your appliance for guarantee purposes.

Appliance Model	<input type="text"/>
-----------------	----------------------

Serial Number	<input type="text"/>
---------------	----------------------

### Declaration of CE Conformity

This cooktop has been designed, constructed and marketed in compliance with:

- Safety requirements of EU Directive "Low Voltage" 2006/95/EC;
- Protection requirements of EU Directive "EMC" 2004/108/EC;
- Requirements of EU Directive 93/68/EEC.

### Important Information for Correct Disposal of the Product in Accordance with EC Directive 2002/96/EC.

At the end of its working life, the product must not be disposed of as urban waste. It must be taken to a special local authority differentiated waste collection centre or to a dealer providing this service.

Disposing of a household appliance separately avoids possible negative consequences for the environment and health deriving from inappropriate disposal and enables the constituent materials to be recovered to obtain significant savings in energy and resources. As a reminder of the need to dispose of household appliances separately, the product is marked with a crossed-out wheeled dustbin.



## Before Using for the First Time

- Read the instructions carefully before installing and using the appliance.
- After unpacking the appliance, make sure it is not damaged. In case of doubt, do not use the appliance and contact your supplier or a qualified engineer.
- Remove all packaging and do not leave the packing material (plastic bags, polystyrene, bands etc) in easy reach of children as they may cause serious injury. The packaging materials are recyclable.
- The appliance should be installed and all the electrical connections made by a qualified engineer in compliance with local regulations in force and following the manufacturer's instructions.
- Do not attempt to modify the technical properties of the appliance, as it may become dangerous to use.

## Important Safeguards and Recommendations

- Do not carry out any cleaning or maintenance without first disconnecting the appliance from the electrical supply.
- During and after use of the hob, certain parts will become very hot. Do not touch hot parts.
- After use always ensure that the controls are in the **OFF** position.
- Household appliances are not intended to be played with by children.
- Keep children away from the hob during use.
- Children, or persons with a disability which limits their ability to use the appliance, should have a responsible person to instruct them in its use. The instructor should be satisfied that they can use the appliance without danger to themselves or their surroundings.
- **WARNING**  
When correctly installed, your product meets all safety requirements laid down for this type of product category. However special care should be taken around the underneath of the appliance as this area is not designed or intended to be touched and may contain sharp or rough edges, that may cause injury.
- **Fire Risk!** Do not leave inflammable materials on the Hob top.
- Make sure that electrical cords connecting other appliances in the proximity cannot come in to contact with the Hob top.
- Do not allow heavy or sharp objects to drop on the glass ceramic hob. If the hob is cracked or damaged, disconnect the appliance from the electrical supply and call the after-sales service.
- Do not scratch the hob with sharp objects. Don't use the hob as a work surface.
- Before disposing of an unwanted appliance, it is recommended that it is made inoperative and that all potentially hazardous parts are made harmless.
- **Important:** This appliance has been designed for domestic use only. The appliance is NOT suitable for use within a semi-commercial, commercial or communal environment.
- **If the supply cord is damaged, it must be replaced by the manufacturer or its service agent or a similarly qualified person in order to avoid a hazard.**
- Do not operate your appliance by means of an external timer or separate remote-control system.

## Features and Technical Data

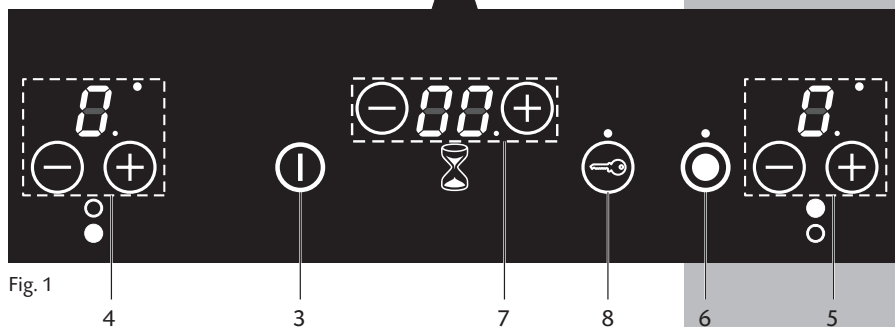
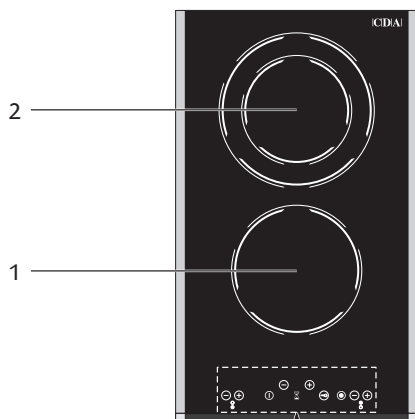

Fig. 1

### Cooking Zones

1. Hi-light cooking zone  $\varnothing$  140 mm - 1200 W
2. Double hi-light cooking zone  $\varnothing$  180/120 mm - 1700/700 W

### Touch-Control Description

3. ON/OFF key
4. Front zone (1) keys (increasing and decreasing power)
5. Rear zone (2) keys (increasing and decreasing power)
6. ON/OFF outside zone of rear double cooking zone (2)
7. Automatic cooking timer keys
8. Child lock selection

**Electrical insulation  
Class I**

## Cooking Zones Features

The ceramic surface of the hob allows a fast transmission of heat in the vertical direction, from the heating elements underneath the ceramic glass to the pans set on it.

The heat does not spread in a horizontal direction, so that the glass stays "cool" at only a few centimeters from the cooking plate.

The 2 cooking zones are shown by painted disks on the ceramic surface.

Before switching on the cooktop make sure that it is clean.

### Important Note:

The heating elements incorporate a thermolimiter that switches the element ON/OFF during all settings to protect the ceramic glass from overheating.

The use of incorrect pans and/or wrong pan positioning will cause the temperature limiter to operate more frequently, resulting in a reduction of cooking performance.

The temperature limiter can be seen under the glass dissecting the element. This is not a fault with the appliance.

### Hi-Light Radiant Zone (Fig. 2)

The heating element is formed of a coil of resistant material which reaches the working temperature quickly.

### Hi-Light Double Zone (Fig. 3)

The heating element is formed of a 2 coils of resistant material which reaches the working temperature quickly.

By switching OFF the second element (fig. 3), the surface area of this zone can be reduced.

For this purpose see page 11.

Hi-light Radiant Zone

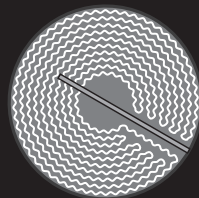

Fig. 2

Hi-light Double Zone

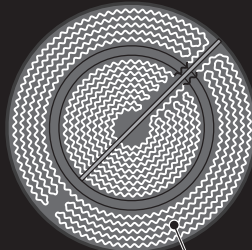

Fig. 3

Second element

## Cooking Hints

Power Level	Type of cooking
<b>0</b>	Switched OFF
<b>1</b> <b>2</b>	For melting operations (of butter or chocolate).
<b>3</b>	To keep foods warm or heat small quantities of water.
<b>4</b> <b>5</b>	To heat greater quantities of water and to whip creams and sauces.
<b>5</b> <b>6</b>	Slow boiling, e.g. spaghetti, soups, boiled meats, to continue steam heating of roast meats and stews.
<b>6</b>	For all kinds of fried foods, steaks, cutlets and cooking without a lid.
<b>7</b> <b>8</b>	For browning of meat, cooked potatoes, fried fish and for boiling large quantities of water.
<b>9</b>	Rapid frying, grilled steaks, etc.

After a short period of use, experience will teach you which setting is the right one for your needs.

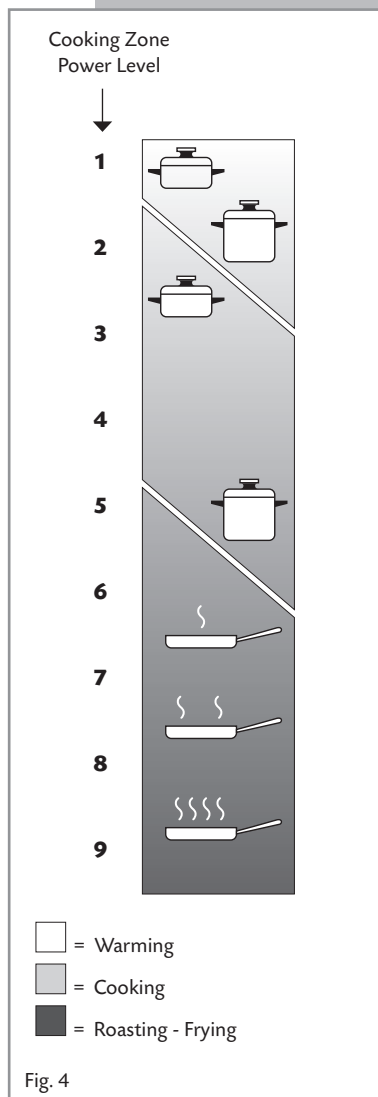

## Residual Heat Indicators

When the temperature of a cooking plate is above 65°C, the relevant **H** in the touch control display is also lit-up (with the cooking plate switched off) to warn of heat on the surface of the hob.

This **H** symbol also stays on after the touch control panel has been switched off to show that the hob surface is still hot.

**This residual heat lasts for a rather long time after the cooking plate has been switched off.**

**During this time you should avoid touching the hob surface over the cooking area.**

Please pay special attention to ensure that children are not allowed near the hob.

The **H** symbol will switch off automatically as soon as the surface temperature of the cooking plate falls below 65 °C.

## Cooking Hints:

- To reduce the cooking time, you can set the fast cooking function (cf. section "Fast Automatic Heating of the Cooking Zones" at page 12).
- You should use pots and pans with flat bases (pans with the test mark for glass-ceramic hobs are available from specialist shops).
- The diameter of the pan should match that of the cooking plate (or be slightly bigger) to make the most of the energy.
- Since the cooking surface stays hot for a certain time after the plate has been switched off, you can switch it off 5 or 10 minutes before the end of the cooking.  
The residual heat of the hob will complete the cooking.
- To save electricity, use pan lids whenever possible.

**Never cook the food directly on the glass ceramic cooktop, but in special pans or containers.**

**WARNING:**  
**Hobs become very hot with use, and retain their heat for a long time after cooking has finished (about 30 minutes).**  
**Children should be supervised at all times and be prevented from touching the hot surfaces, until such time as the appliance has cooled.**

## Safety Hints

- Before you switch the hob on, make sure you know which control keys control the required cooking zone. We advise you to set the pan over the cooking zone before switching it on.
- Do not use pots and pans with rough bases (pay attention to cookware made of cast-iron). Rough bases can damage the glass surface of the hob (scratches).
- Always ensure that the base of your saucepan is clean and dry before placing on the hob.
- Pots with aluminium bottoms may leave silver streaks or spots on the hob.
- Do not leave wet or damp lids on the hob.
- The glass-ceramic surface and pans must be clean. Carefully eliminate any food remains (especially containing sugar), dirt etc. with the aid of a cleansing agent.
- Pan handles should never stand out beyond the kitchen worktop, as there is a great danger of knocking the pan over. This will also ensure that children cannot reach them.
- **Do not use the hob if the glass surface is broken or cracked in any way. Please disconnect the hob from the mains and contact the after-sales service.**
- Do not lean over the cooking plate when in use.
- Do not lay cooking foil or plastic materials on the ceramic surface when it is hot.
- Remember that the surface remains hot for a long time (about 30 min.) after the cooking plate has been switched off.
- Follow the cleaning instructions carefully.
- Never use the glass surface for storage.

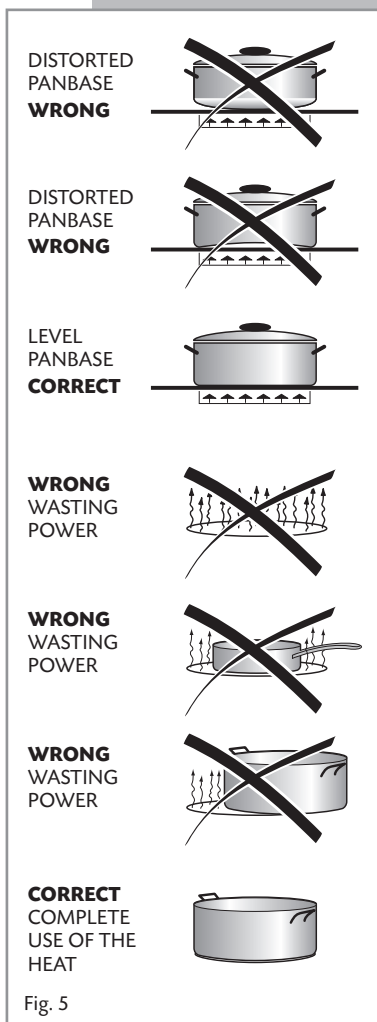

- DO NOT USE GLASSWARE ON CERAMIC HOBBS.
- DO NOT USE PANS WITH ROUGH CIRCULAR MACHINED BASE.

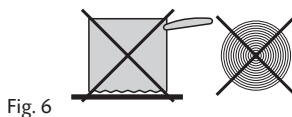





## How to Use the Touch-Control

### Notes:

- Each selection (by pressing one of the keys) is indicated by an acoustic signal (beep).
- If the environmental light conditions are excessive (e.g. halogen hood light/s on), the user interface operation could be stopped (the displays show "F" and "L" alternating - error message "FL") until the correct light conditions will be recovered.  
In this case the direct environmental light/s must be switched off before operating the cooktop.

- Any time the cooktop is connected to the electrical supply or after a power failure, the safety key-lock protection will be automatically activated (indicator light **ON** above key ). Before starting to use the cooktop deactivate the key-lock protection by pressing the key . This operation is necessary for the keyboard calibration, to adapt the sensibility of the keys (do not use gloves, use a clear finger).

- If an object is positioned on the touch control area, or in the case of spillage of liquids on control keys, the touch control is switched off automatically 10 seconds after having detected the object/liquid.
- When the touch control reaches an ambient temperature above 96°C, one heating element is switched off. This element cannot be used until the temperature falls below 89°C.

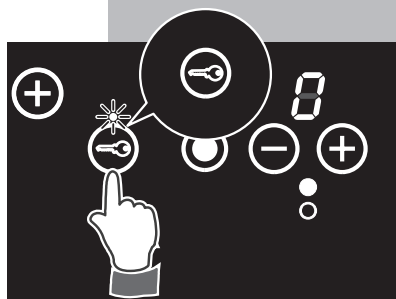

## How To Turn the Touch Control ON and OFF

### Switching ON

Press the key ① and keep it pressed until the touch control is lighted.

The displays of the cooking zones read "0".

#### Notes:

- If the safety key-lock protection is active, the touch control can be turned **ON** only after having deactivated this protection.
- Auto switch-off: If a cooking zone is not turned **ON** within 10 seconds, the touch control will automatically switch off. Then the safety key-lock protection is automatically activated after about 1 minute.

### Switching OFF

The touch control may be switched **OFF** at any time by pressing the key ①.

If any cooking zones are turned **ON**, they will be turned **OFF**.

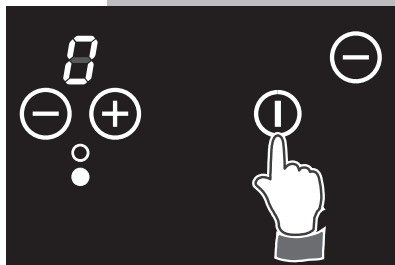

## Power Ignition and Adjustment of a Cooking Zone

To turn **ON** a cooking zone the touch control must be switched **ON** (see section "How To Turn the Touch Control ON and OFF").

Press the key  $\oplus$  and keep it pressed until the desired power level, ranging between 1 and 9 is set.

As an alternative, press the key  $\ominus$ . The choice starts from level 9 (maximum level) down to 1 (minimum level).

To reset the power level press the key  $\ominus$  and keep it pressed until power level zero (0) or alternatively press the keys  $\oplus$  and  $\ominus$  at the same time.

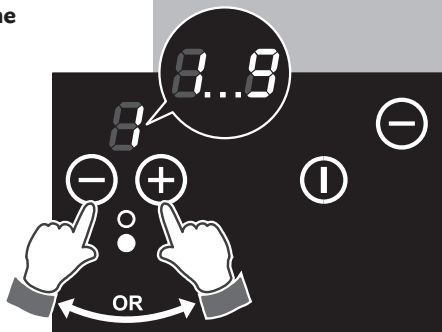

## Functioning of the Double Cooking Zone

The double cooking zone consists of two circuits, which may be used in the following modes:

- Reduced cooking zone: only the first heating unit is switched **ON**.
- Extended cooking zone: the first and second heating circuits are both switched **ON**.

Turn on the cooking zone as described in the section: "Power Ignition and Adjustment of a Cooking Zone"; only the first heating unit will switch on.

Press the key  $\odot$  to operate also the second heating circuit (the indicator light close to the key will light up), then set the desired power level by using the keys  $\oplus$  and  $\ominus$ .

To turn off the second heating circuit press the key  $\odot$  (the indicator light close to the key will go out).

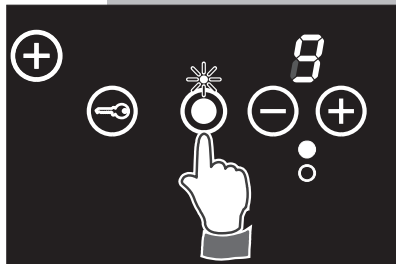

## Afterheat in Cooking Zone/s

When switching off a cooking zone (power level 0), if the temperature of the zone is too warm to be touched the display will show alternately "H" and "0".

Whenever the touch control is switched off, the residual heat is shown by a static "H".

"H" is turned OFF when the cooking zone temperature drops below 65 °C.

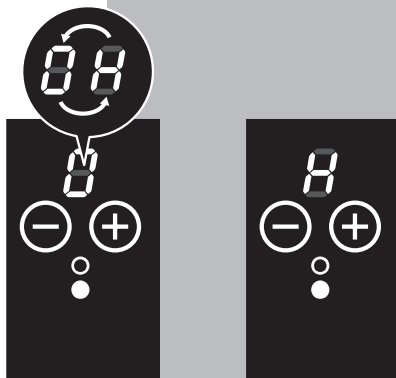

### Fast Automatic Heating of the Cooking Zones

This function permits fast heating up at the maximum power level, followed by heating at the preset power level. The duration of the automatic fast heating up period is preset and depends on the selected power level.

To activate the heat-up function select the power level "9" and then touch again the key (+); the luminous point at the bottom right side of the display will blink for 10 seconds. During these 10 seconds the desired power level shall be selected (between 1 and 8). After this time a beep sounds and the luminous point remains fixed (not blinking), indicating that the heat-up function is **ON**.

If the power level is "0" or "9", the heat-up function is cancelled.

If the heat-up function is activated, by pressing the key (+) the duration of the heat-up function will be the duration of the new power level. If the new power level is "9", the function is cancelled.

### Cancelling the Heat-Up Function

The heat-up function can be cancelled:

- automatically (when the time expires) - a beep sounds, the luminous point goes out, the power level of the heater remains the selected power level;
- by the user - by pressing the key (-) the function is cancelled.

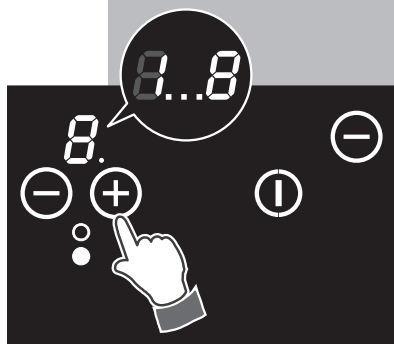
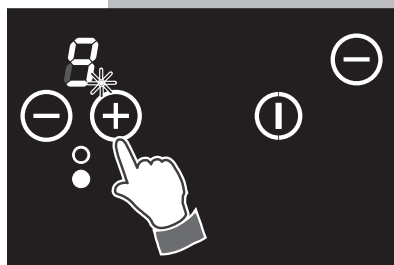

Heat-Up Function Time								
Cooking zone power level	1	2	3	4	5	6	7	8
Fast heating time	1 min. & 12 sec.	2 min. & 44 sec.	4 min. & 48 sec.	5 min. & 28 sec.	6 min. & 30 sec.	1 min. & 12 sec.	2 min. & 44 sec.	2 min. & 44 sec.

## Safety Key-Lock to Protect Children

This function locks the touch-control keys against unwanted activation.

To activate the key-lock press the key ; the indicator light above the key symbol will light up.

- Cooking zone/s operating (power level already set) - with the key-lock protection active it is only possible to switch off the cooktop.
- Cooktop off - with the key-lock protection active it is not possible to use the cooktop. To use the cooktop deactivate this protection.

To deactivate the key-lock protection just press the key ; the indicator light above the key symbol will go out.

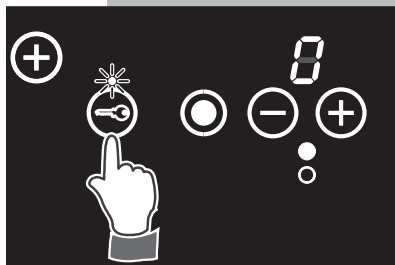

## Program for Automatic Switching OFF of One Cooking Zone

This function permits to set a timer from 1 to 99 minutes for automatic turning **OFF** of one cooking zone only.

**Note:** It is not possible to set this program for both the cooking zones.

With the touch control switched **ON** press the timer keys (+) or (-).

By pressing the key (+) the initial value is 0.

By pressing the key (-) the initial value is 99.

The displays of the cooking zones show "t" (timer).

Then, within 10 seconds, set the cooking zone to be programmed as indicated in the chapter "Power Ignition and Adjustment of a Cooking Zone".

The indicator light on the top right of the cooking zone display lights up.

Then set the timer; press the timer keys (+) or (-) to increase or reduce the value.

The indicator light on the bottom right of the timer display lights up.

Now the program for automatic switching off is complete.

At the end of the countdown the cooking zone will switch off automatically and an acoustic signal (beep) will sound (for one minute only) and "00" will flash on the timer display.

Press any button of the touch control to reset the timer.

**Note:** The program for automatic switch off can be cancelled at any time by resetting the power level of the cooking zone (power level "0").

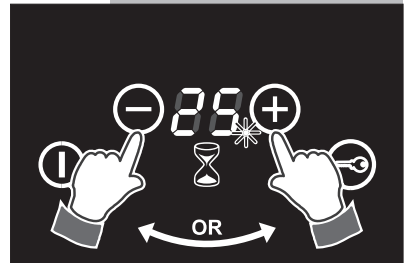
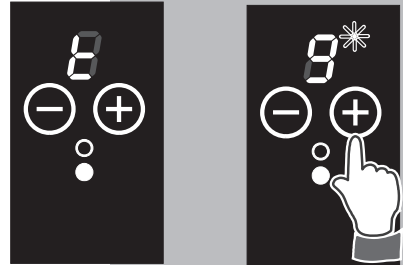
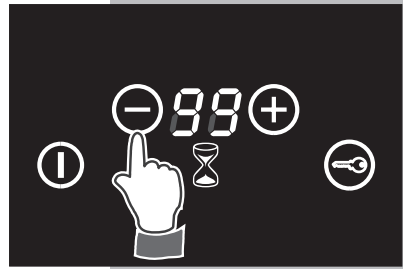
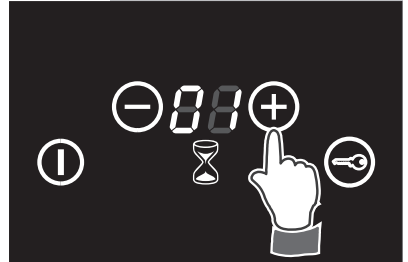

### Operation Time Limit of Cooking Zones

Each cooking zone is automatically switched **OFF** after a maximum preset time if no operation is performed.

The maximum preset time limit depends on the set power level, as illustrated in this schedule.

Each operation on the cooking hob by using the keys  $\oplus$ ,  $\ominus$  will reset the maximum operation time at its initial value.

Cooking Zone Power Level	Operation Time Limit
1	10 hours
2	5 hours
3	5 hours
4	4 hours
5	3 hours
6	2 hours
7	2 hours
8	2 hours
9	1 hour

### Error Code on the Display/s

If an error message appears on the display/s (the display/s show/s "F" and another character alternating - e.g. "F" and "R", "F" and "0", .....):

1. Disconnect the cooktop from the mains.
2. Reconnect the cooktop and turn it on.
3. Wait for about two minutes and if the problem does not appear the cooktop can be used.
4. If the problem does not disappear repeat step from 1 to 3.
5. If the problem continues, disconnect the cooktop from the mains and contact your Authorised Service Centre.

**Important:** In the case of error message "F" and "L" see note at page 9.

### Display/s OFF or Not Correctly Operating

**If a display or the displays are only partially lit or not lit.**

1. Switch off the cooktop and disconnect it from the mains.
2. Reconnect the cooktop and turn it on.
3. Wait for about two minutes and if the problem does not appear the cooktop can be used.
4. If the problem does not disappear repeat step from 1 to 3.
5. If the problem continues, disconnect the cooktop from the mains and contact your Authorised Service Centre.

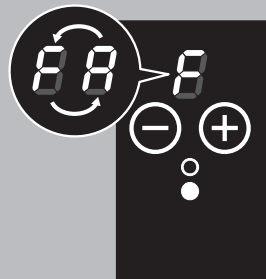



## Cleaning and Maintenance

### Cleaning the Ceramic Hob

- Remove spillages and other types of incrustations.
- Dust or food particles can be removed with a damp cloth.
- If you use a detergent, please make sure that it is not abrasive or scouring. Abrasive or scouring powders can damage the glass surface of the hob.
- All traces of the cleaner must be removed with a damp cloth.
- Dust, fat and liquids from food that has boiled over must be removed as soon as possible.
- If they are allowed to harden they become increasingly difficult to remove. **This is especially true in the case of sugar/syrup mixtures which could permanently pit the surface of the hob if left to burn on it.**
- If any of these products has melted on the ceramic surface, you should remove it immediately (when the surface is still hot) by using a scraper to avoid any permanent damage to the surface of the hob.
- Do not put articles on the hob which can melt: i.e plastic, aluminium foil, sugar, sugar syrup mixtures etc.
- Avoid using a knife or other sharp utensil as these may damage the ceramic surface.
- Do not use steel wool or an abrasive sponge which could scratch the surface permanently.

### Stainless Steel Elements (Side Stainless Steel Trims)

- Stainless steel parts must be rinsed with water and dried with a soft and clean cloth.
- For persistent dirt, use specific non-abrasive products available commercially or a little hot vinegar.

**Before you begin cleaning make sure that the hob is switched off.**

**Do not use a steam cleaner because the moisture can get into the appliance thus make it unsafe.**



Fig. 7

## TIPS FOR INSTALLATION

### Installation

#### CAUTION:

**This appliance shall only be serviced by authorised personnel.**

- **This appliance is to be installed only by an authorised person according to the current local regulations and in observation of the manufacturer's instructions.**
- **Incorrect installation, for which the manufacturer accepts no responsibility, may cause personal injury or damage.**
- **Always disconnect the cooktop from mains power supply before carrying out any maintenance operations or repairs.**

#### WARNING !

- We would point out that the adhesive which bonds the plastic laminate to the furniture must withstand temperatures not less than 150 °C to avoid delamination.
- The appliance must be housed in heat resistant units.
- The walls of the units must be capable of resisting temperatures of 75 °C above room temperature.

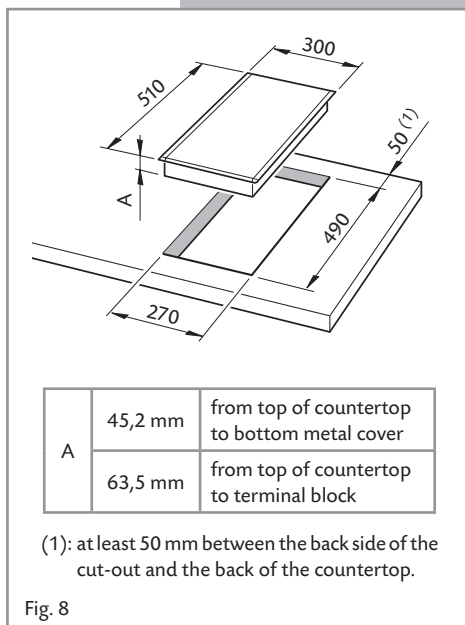

This cooktop can be built into a working surface 20 to 40 mm thick and 600 mm deep.

In order to install the ceramic hob into the kitchen fixture, a hole with the dimensions shown in figure 8 has to be made, keeping in consideration the following:

- Within the unit, between the bottom of the hob and the upper surface of a shelf there must be a clearance of at least 30mm (fig. 9).
  - It is absolutely essential that you place a separator between the base of the hob and the built-in unit.
  - If the hob is installed over a built-in oven, there must be a distance of at least 30mm between the two appliances. The oven shall be provided with cooling fan. The two appliances should be connected to the electrical supply with independent connections.
  - The ceramic hob must be kept no less than 50 mm away from any side wall.
  - The rear wall must be at least 50 mm from the ceramic hob.
  - There must be a distance of at least 650 mm between the hob and any wall cupboard or extractor hood positioned immediately above (see fig. 10).
  - The coatings of the walls of the unit or appliances near the cooktop must be heat resistant.
- Do not install the appliance near inflammable materials (eg. curtains).**

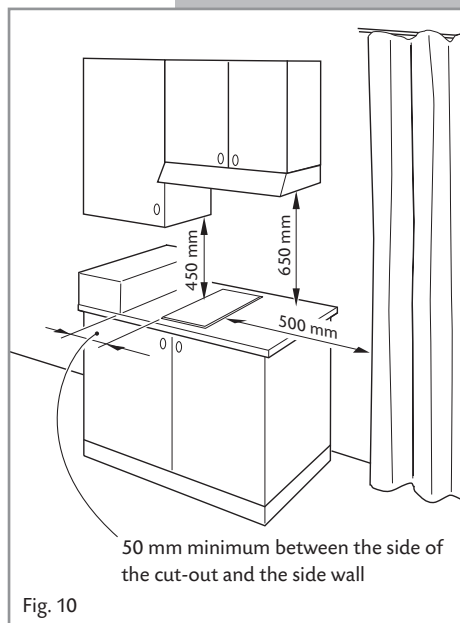
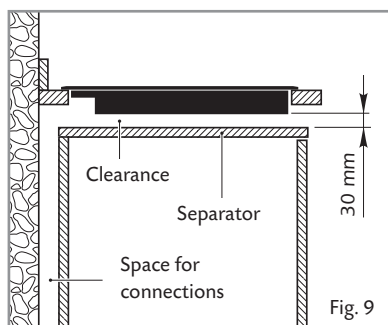

## Fastening the Cooktop

Each cooktop is supplied with a set of tabs and screws to fasten it on units with a working surface from 2 to 4 cm deep.

The kit includes 4 tabs **A** and 4 self-threading screws **B** (fig. 11).

- Cut the unit.
- Turn the hob upside down and rest the glass side on a cloth.
- Spread the seal **C** around the edge of the hob (fig. 12).
- Put tabs **A** into the mountings; only tighten screws **B** a few turns.  
Make sure that the tabs are mounted correctly as shown in the figure 11.
- Put the cooktop into the hole cut into the unit and position it correctly.
- Put tabs **A** into place, tooth **D** of the tabs should go into the hole.
- Tighten screws **B** until the cooktop is completely secured.
- Using a sharp tool cut off the part of gasket **C** which protrudes from the cooktop. Take care not to damage the workbench.

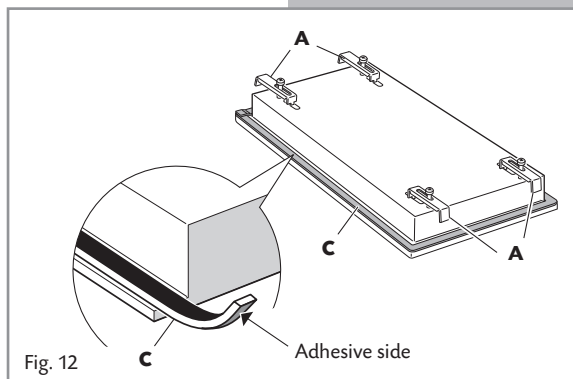
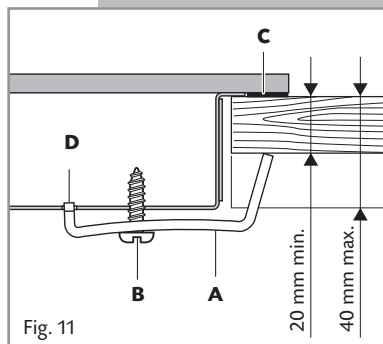

## Mains Electricity Connection

**Incorrect installation may be dangerous and the manufacturer can not be held responsible.**

**Warning! This appliance must be earthed. The manufacturer declines all responsibility for any problem caused by failure to observe this rule.**

THIS APPLIANCE MUST BE CONNECTED TO THE MAINS SUPPLY BY A COMPETENT PERSON, USING FIXED WIRING VIA A DOUBLE POLE SWITCH AND PROTECTED BY A SUITABLE FUSE. THIS APPLIANCE IS NOT SUITABLE FOR CONNECTION TO A 13A PLUG OR SUPPLY.

We recommend that the appliance is connected by a qualified electrician, who is a member of the N.I.C.E.I.C. and who will comply with the I.E.E. and local regulations.

The wires in the mains lead of this appliance are coloured in accordance with the following code:

**Green & Yellow = Earth, Blue = Neutral, Brown = Live.**

As the colours of the wires in the mains lead for the appliance may not correspond with the coloured markings identifying the terminals connecting to the fuse spur, proceed as follows:

- The wire which is coloured green and yellow must be connected to the terminal marked E (Earth) or coloured green.
- The wire which is coloured blue must be connected to the terminal marked N (Neutral), or coloured black.
- The wire which is coloured brown must be connected to the terminal marked L (Live), or coloured red.

**Note: Use a suitable fuse (16A minimum).**

The mains cable must only be replaced by a qualified electrician or service engineer and must be of equivalent or better rating (i.e. 1.5mm<sup>2</sup>, H05RR-F).

Assembly and electrical connection should be carried out by specialised personnel.

When installing this product we recommend you seek the help of another individual.

## Connection of the Power Supply Cable

Unhook the terminal board cover by inserting a screwdriver into the two hooks **A** (fig. 13).  
Open the cable gland by unscrewing screw **F** (fig. 14), unscrew the terminal screws and remove the cable.  
The new supply cable, of suitable type and section, is connected to the terminal board following the diagram of fig. 15.

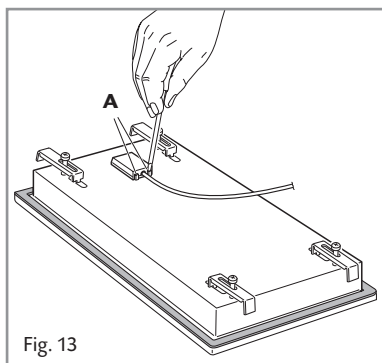

Fig. 13

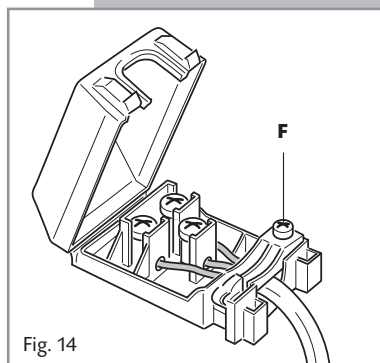

Fig. 14

## Feeder Cable Section

### Type H05RR-F

230 V~ 3 x 1.5 mm<sup>2</sup>

230 V ~

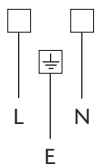

E  $\perp$  Earth  
N Neutral  
L Live

Fig. 15

## Appliance Servicing

CDA provide a quality and effective after-sales service to cover all your servicing needs.

Please attach your receipt to this page for safekeeping.

Please help us to help you by having the following information available when booking a service-call:

1. Model type, make and model – see the product data plate.
2. Evidence of installation / purchase date
3. Retailer where appliance was purchased
4. Clear and concise details of the fault
5. Full address including postcode and any contact phone numbers

### Contact Telephone Numbers

CDA Customer Care Department

– Telephone: 01949 862012

– Fax: 01949 862003

– Email: [service@cda.eu](mailto:service@cda.eu)

## Guarantee

CDA appliances carry a five-year parts and a one-year labour guarantee.

CDA will repair or replace any defect or part attributable to faulty material or workmanship. Within the first year this will be free of both labour and parts charges. After the first year and within five years, the parts will be supplied free of charge provided that the repair is carried out by an agent authorised by CDA and the labour will be charged at the commercial rate applicable at the time of repair.

The appliance must have been installed by a suitably qualified person and in accordance with the manufacturer's instructions and current legislation. The guarantee does not cover faults caused by the incorrect fitting of appliances.

### Limit of Cover

- The guarantee does not cover cosmetic damage e.g. discolouration or oxidation.
- Proof of purchase or installation date must be produced before a service-call will be booked.
- The appliance must be used for domestic purposes only. Appliances used for commercial or professional purposes are not covered by the guarantee. Commercial warranty is available at extra cost.
- The appliance must not be modified or tampered with or repair attempted by any unauthorised person.
- The guarantee does not cover damage caused in transit or by misuse, accident, abuse or neglect.
- The guarantee does not cover routine maintenance.
- Use of parts not supplied or recommended by |C|D|A| will invalidate the warranty.
- Rubber seals, filters, removable glass parts, control knobs and buttons, fuses and light bulbs will need replacing periodically and are not covered by the guarantee.
- Second-hand or reconditioned appliances are not covered by the guarantee.

The conditions under which this guarantee is offered are in addition to the statutory rights of the domestic purchaser and these statutory rights are not affected by this guarantee.

CDA reserve the right to change specification without prior notice.



To contact our Customer Care Department, or for Service,  
please contact us on the details below.



## Free Manuals Download Website

<http://myh66.com>

<http://usermanuals.us>

<http://www.somanuals.com>

<http://www.4manuals.cc>

<http://www.manual-lib.com>

<http://www.404manual.com>

<http://www.luxmanual.com>

<http://aubethermostatmanual.com>

Golf course search by state

<http://golfingnear.com>

Email search by domain

<http://emailbydomain.com>

Auto manuals search

<http://auto.somanuals.com>

TV manuals search

<http://tv.somanuals.com>