

**RV 1060 ..**  
**Twin Cavity Ceramic Cooker**  
**Manual for Installation, Use and Maintenance**

**|C|D|A|**

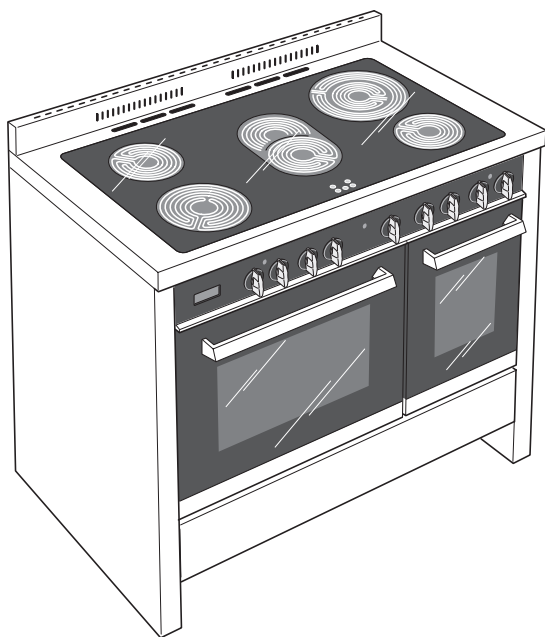

**CE**



## Important

This appliance is designed and manufactured solely for the cooking of domestic (household) food and is not suitable for any non domestic application and therefore should not be used in a commercial environment.

The appliance guarantee will be void if the appliance is used within a non domestic environment i.e. a semi commercial, commercial or communal environment.

The CDA Group Ltd cannot be held responsible for injuries or losses caused by incorrect use or installation of this product. Please note that CDA reserve the right to invalidate the guarantee supplied with this product following incorrect installation or misuse of the appliance.

### Appliance Information:

Please enter the details on the appliance rating plate below for reference, to assist CDA Customer Care in the event of a fault with your appliance and to register your appliance for guarantee purposes.

Appliance Model	<input type="text"/>
Serial Number	<input type="text"/>

### Declaration of CE Conformity

This cooker has been designed, constructed and marketed in compliance with:

- Safety requirements of EU Directive "Low Voltage" 2006/95/EC;
- Protection requirements of EU Directive "EMC" 2004/108/EC;
- Requirements of EU Directive 93/68/EEC.

### Important Information for Correct Disposal of the Product in Accordance with EC Directive 2002/96/EC.

At the end of its working life, the product must not be disposed of as urban waste. It must be taken to a special local authority differentiated waste collection centre or to a dealer providing this service.

Disposing of a household appliance separately avoids possible negative consequences for the environment and health deriving from inappropriate disposal and enables the constituent materials to be recovered to obtain significant savings in energy and resources. As a reminder of the need to dispose of household appliances separately, the product is marked with a crossed-out wheeled dustbin.



## Features and Technical Data

### Vitroceramic Cooking Hob

- |   |             |             |
|---|-------------|-------------|
| 1. 3-circuit cooking zone                 | Ø 180       | 1700 W      |
| 2. 3-circuit cooking zone                 | Ø 145       | 1200 W      |
| 3. Oval cooking zone                      | Ø 145 x 250 | 1800/1000 W |
| 4. Double cooking zone                    | Ø 210/120   | 2100/700 W  |
| 5. 3-circuit cooking zone                 | Ø 145       | 1200 W      |
| 6. Cooking zones residual heat indicators |             |             |

### Attention:

Detach the appliance from the mains if the ceramic hob is cracked and contact the After-Sales service.

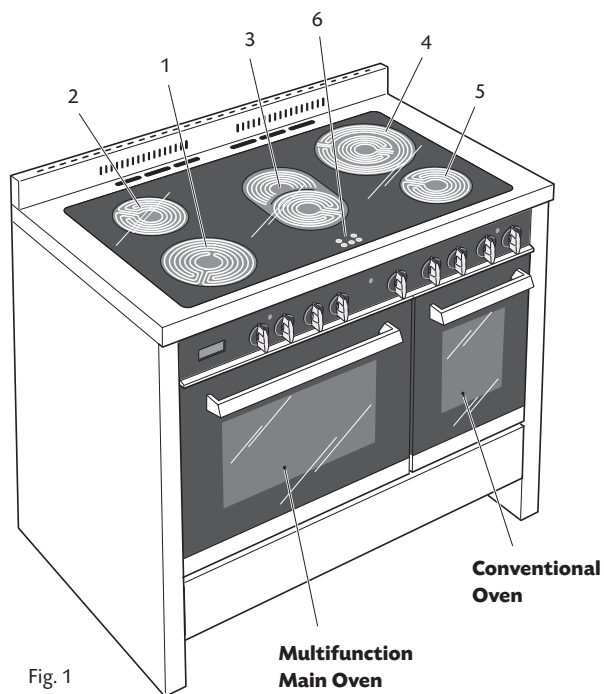

Fig. 1

## Control Panel

### Controls Description

1. Front right cooking zone control knob
2. Rear right cooking zone control knob
3. Central cooking zone control knob
4. Rear left cooking zone control knob
5. Front left cooking zone control knob
6. Multifunction main oven switch control knob
7. Multifunction main oven thermostat control knob
8. Clock and timer with "Touch-Control" keys (main oven only)
9. Conventional oven thermostat control knob
10. Conventional oven switch control knob

### Pilot Lamps:

11. Main oven thermostat indicator light
12. Conventional oven thermostat indicator light
13. Cooking hob ON indicator light

**Please note:** This appliance incorporates a safety cooling fan which you will hear operating whenever the oven or grill are in use. The cooling fan may also operate when the oven is switched off. This fan is to reduce the external temperature of the appliance and cool the internal components.

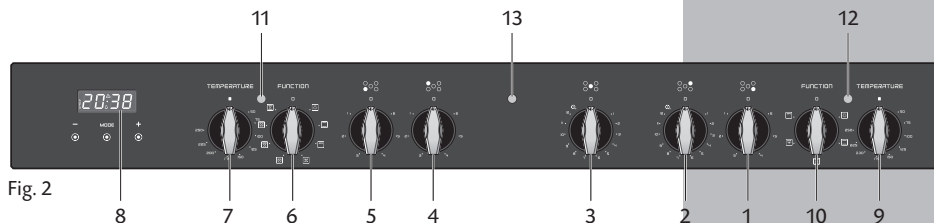

Fig. 2

## Clock and Timer with "Touch-Control" Keys

(Multifunction Main Oven only)

### Keys:

- + and - Touched simultaneously (for more than 2 seconds):
- setting the clock;
  - setting the timer volume (by touching once, along with the "MODE" key);
  - to cancel automatic cooking at any time.

**MODE** Function selection (touched for more than 2 seconds):

- setting the clock (only after first connection or after a power failure);
- timer;
- automatic cooking "dur" (duration) - how long the food will take to cook (by touching the "MODE" key again);
- automatic cooking "End" - the time you would like the oven turns off (by touching the "MODE" key two more times);

+ Increases the number shown on the display

- Decreases the number shown on the display

### Illuminated Symbols:

- AUTO** *flashing* - Automatic cooking completed, oven in automatic position but not set
- AUTO** *steady illumination* - Oven set for automatic cooking, cooking still not taking place
- "🔔" *flashing* - Timer being set
- "🔔" *steady illumination* - Timer in operation
- "🔥" *steady illumination* - Oven set for manual cooking
- "🔥" and **AUTO** *AUTO flashing* - Automatic cooking being set
- "🔥" and **AUTO** *steady illumination* - Oven set for automatic cooking, cooking taking place.



## “Touch-Control” Keys

The “touch-control” keys shall be operated by the fingers (just by touching the key). When using touch controls it is best to use the ball of your finger rather than the tip.

The keys are automatically deactivated:

- 8 seconds after the last selection; the deactivation is indicated by an acoustic signal (“beep”).
- To reactivate just touch the “**MODE**” key or the “+” and “-” keys.

## Setting the Clock

When first connected, or after a power failure, the digits and “**AUTO**” will shown on the display. To set the clock, touch the “**MODE**” key, for more than 2 seconds, and then the “+” or “-” keys.

Important: The oven does not operate, in manual cooking, without first having set the clock.



To set the clock, with the appliance already connected, touch the “+” and “-” keys simultaneously (for more than 2 seconds), then “+” or “-” keys.

**Important:** - **changing the time will delete any automatic program;**  
 - **after setting the clock, the oven starts to operate in the selected function (manual cooking). The “” symbol is steady illuminated.**

## Using the Timer

You can use the timer at any time, even when the oven is not in use. The timer does not turn the oven off.

The timer can be set for up to 23 hours and 59 minutes.

- To set the timer, touch the “**MODE**” key for more than 2 seconds (the “” symbol flashes), than the “+” or “-” keys.
- After about 8 seconds an acoustic signal (“beep”) will sound confirming the regulation (“” symbol steady illuminated).
- To check the remaining time touch the “**MODE**” key for more than 2 seconds. If the remaining time is more than a minute the display will show hours and minutes; if less than a minute the display will show seconds.
- When the time is up, the timer will beep. Touch the “**MODE**” key, for more then 2 seconds, to turn it off; or press the “+” or “-” key to stop the beep and than the “**MODE**” key, for more than 2 seconds, to deactivate the “” symbol flashing on the display.
- Turn off the oven manually (function and thermostat knobs in the off position) if the manual cooking has been completed.

## Setting the Timer Volume

You can select from three volume levels.

- Touch the “+” and “-” keys simultaneously for more than 2 seconds.
- Touch the “**MODE**” key; you can read on the display the current timer volume (“**ton1**”, “**ton2**” or “**ton3**”).
- Touch the “-” key to listen or change the timer volume.
- Timer volume activated: the last displayed.
- After about 8 seconds an acoustic signal (“beep”) will sound confirming the volume setting; then the time of day will be displayed.

## Automatic Cooking

Use automatic cooking to automatically turn the oven on, cook, and then turn the oven off.

1. Check the clock shows the correct time.
2. Select the function and temperature (function and temperature knobs). The oven will come on.
3. Decide how long the food will take to cook, allowing time for preheating if necessary.
4. Touch the **"MODE"** key for more than 2 seconds and then touch again. **"dur"** will show (duration). Using the **"+"** and **"-"** keys, set the stop time.
5. Decide the time you would like the oven to turn off; touch the **"MODE"** key for more than 2 seconds and then touch it two times again. **"End"** will show. Using the **"+"** and **"-"** keys, set the stop time.

**Note:** While **"dur"** is displayed you can change to **"End"** just by touching one time the **"MODE"** key (within 8 seconds from the last selection).

If there is time to wait before cooking starts, the current time of day and **"AUTO"** will show in the clock display. The oven will switch off but is now set for automatic cooking.

If you are already at home to turn the oven on and only want the oven to turn off automatically, start cooking as normal, then follow step 4 or step 5 to set a time to stop the oven.

When automatic cooking starts, **"🔥"** will be displayed and the oven will turn on.

- To see the remaining cook time, follow step 4 up to display **"dur"** (duration).
- To see the set stop time, follow step 5 up to display **"End"**.
- To cancel automatic cooking at any time, touch the **"+"** and **"-"** keys simultaneously (for more than 2 seconds) and turn the temperature and function knobs to the off position.

When the stop time is reached, the oven will turn off, the timer will beep and **"AUTO"** will flash:

- Touch any key to stop the beeping.
- Touch the **"MODE"** key, for more than 2 seconds, to return the oven to the manual mode (**"🔥"** symbol steady illuminated on the display).
- Turn the temperature and function knobs to the off position.

**Attention: after a power failure any automatic program is deleted. Turn off the oven manually.**

## How to Use the Vitroceramic Hob

The ceramic surface of the hob allows a fast transmission of heat in the vertical direction, from the heating elements underneath the ceramic glass to the pans sat on it.

The heat does not spread in the horizontal direction, so that the glass stays "cool" at only a few centimeters from the cooking plate.

The 5 cooking plates are shown by painted disks on the ceramic surface.

### Important Note:

The heating elements incorporate a thermolimiter that switches the element ON/OFF during all the settings to protect the ceramic glass from overheating.

The use of incorrect pans and/or wrong pan positioning will cause the temperature limiter to operate more frequently, resulting in a reduction of cooking performance.

### 3-Circuit Radiant Zones

Incorporating 3 heating elements (fig. 4) you can control and light up all 3 together or separately by selecting from the 6 positions on the control knob (fig. 5).

The working temperature required is reached in a very short time.

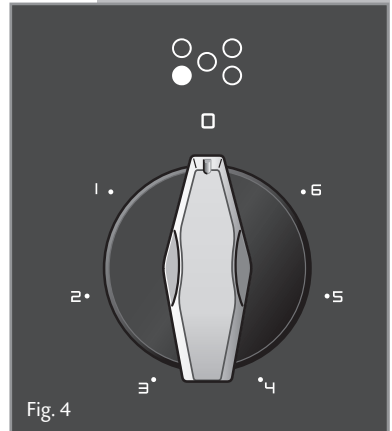

Fig. 4



Fig. 5



## Double and Oval Radiant Zones

The heating element is formed of a coil of resistant material which reaches the working temperature quickly.

Operation of the cooking zone is controlled by a continuous energy regulator from "1" to "12" (maximum temperature) (fig. 6).

To turn on both zones of the double element, turn the double element knob fully clockwise to the position ☉.

To reduce the heat of the full double element, turn its knob anticlockwise to setting 12 or lower.

Adjust the heat during cooking as necessary.

**Note:** if you leave the knob at the ☉ position, the full double element will remain at the highest heat setting.

To **return to using only the inner zone of the double element**, first turn the knob to the ☐ (off) position (you should feel a click) and then clockwise to a setting from 1 to 12.

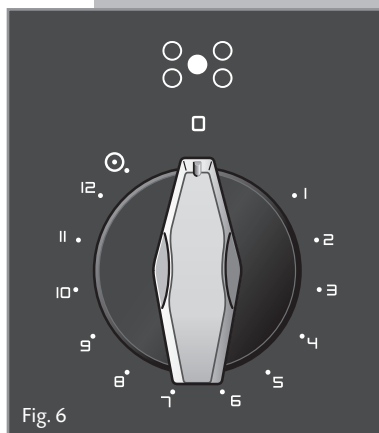

Fig. 6

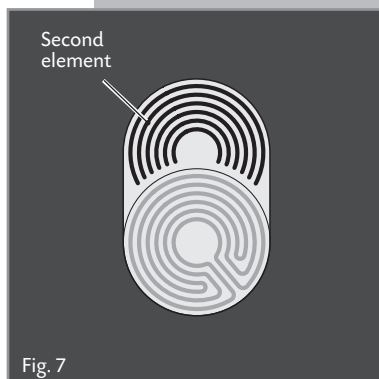

Fig. 7

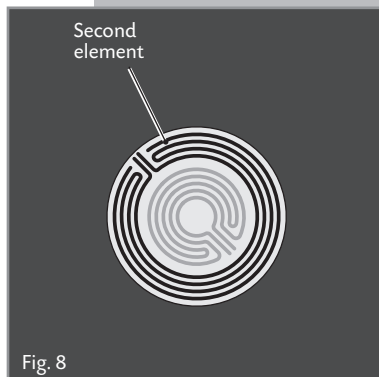

Fig. 8

## Cooking Hints

Position		Type of cooking
0	0	Switched OFF
1	1	For melting operations (of butter or chocolate).
2	2	
2	2	To keep foods warm or heat small quantities of water.
	3	
	4	
3	4	To heat greater quantities of water and to whip creams and sauces.
	5	
	6	
3	6	Slow boiling, e.g. spaghetti, soups, boiled meats, to continue steam heating of roast meats and stews.
4	7	
4	7	For all kinds of fried foods, steaks, cutlets and cooking without a lid.
	8	
4	8	For browning of meat, cooked potatoes, fried fish and for boiling large quantities of water.
5	9	
	10	
6	11	Rapid frying, grilled steaks, etc.
	12	
-	⊙	Switching on the second element (Double and oval radiant zones only)

Hob controlled  
by 7-position  
switch  
**1 - 6**

Hob controlled  
by 12-position  
energy regulator  
**1 - 12**

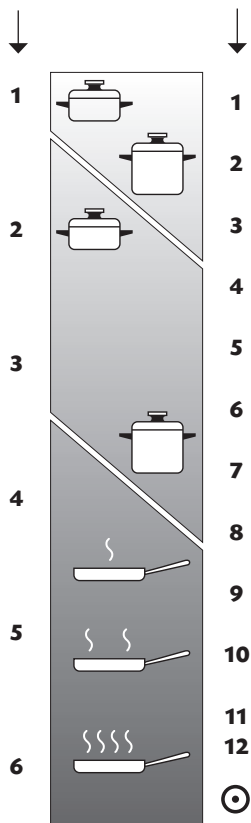

□ = Warming  
 □ = Cooking  
 □ = Roasting - Frying

Fig. 9

After a short period of use, experience will teach you which setting is the right one for your needs.

## Residual Heat Indicators

The hob also features 5 warning lights which are connected to the corresponding plates. When the temperature of a cooking plate is above 60°C, the relevant warning light will also light up to warn of heat on the surface of the hob.

This light also stays on after the cooking plate has been switched off to show that the hob surface is still hot.

This residual heat will last for a long time after the cooking plate has been switched off.

**During this time you should avoid touching the hob surface over the cooking area.**

**Please pay special attention to ensure that children are not allowed near the hob.**

The light will switch off automatically as soon as the surface temperature of the cooking plate falls below 60°C.

## Cooking Hints:

– To reduce the cooking time, you can turn the control knob to the max when you switch the plate on.

After a short time you can set the control knob to the position required for cooking.

– You should only use pots and pans with flat bases (pans with the test mark for glass-ceramic hobs are available from specialist shops).

The diameter of the pan should match that of the cooking plate (or be slightly bigger) to make the most of the energy.

– Since the cooking surface will stay hot for a certain time after the plate has been switched off, you can switch it off 5 or 10 minutes before the end of the cooking.

The residual heat of the hob will complete the cooking.

– To save electricity, use pan lids whenever possible.

– Never cook the food directly on the glass ceramic cooktop.

## Deep Fat Frying

For safety purposes when deep fat frying, do not fill the pan more than one third full of oil.

**DO NOT** cover the pan with a lid and **DO NOT** leave the pan unattended.

In the unfortunate event of a fire, leave the pan where it is and turn off the control knobs.

Place a damp cloth or lid over the pan to smother the flames. Leave the pan to cool for at least 30 minutes before moving the pan.

**DO NOT USE WATER ON THE FIRE.**

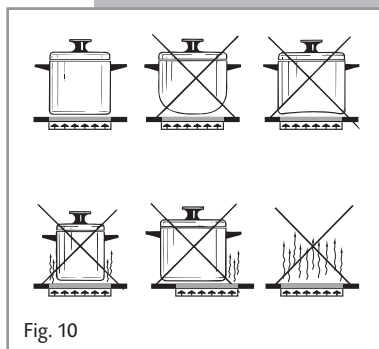

Fig. 10

**– Do Not Use Glassware on Ceramic Hobs.**

**– Do Not Use Pans with Rough Circular Machined Base.**

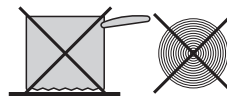

Fig. 11

### Safety Hints:

- Before you switch the hob on, make sure you know which knob controls the required cooking plate. We advise you to set the pan over the cooking plate before switching it on. Remove the pan after you have switched the cooking plate off.
- Do not use pots and pans with rough bases (pay attention to cookware made of cast-iron). Rough bases can damage (scratch) the glass surface of the hob. Make sure that the bottom of the pan is dry and clean.
- Pots with aluminium bottoms may leave silver streaks or spots on the hob.
- Do not leave wet or damp lids on the hob.
- The glass-ceramic surface and pans must be clean. Carefully remove any food debris (especially containing sugar), dirt etc. with the aid of a cleansing agent.
- Pan handles should never stand out beyond the kitchen worktop, as there is a great danger of knocking the pan over.

**This will also ensure that children cannot reach them.**

- **Do not use the hob if the glass surface is broken or cracked in any way. Please disconnect the cooker from the mains and contact the after-sales service.**
- Do not lean over the cooking plate when in use.
- Do not lay cooking foil or plastic materials on the ceramic surface when it is hot.
- Do not use the glass surface for storage.
- Remember that the surface remains hot for a long time (about 30 min.) after the cooking plate has been switched off.
- Follow the cleaning instructions carefully.

### Cleaning the Hob

**Before you begin cleaning make sure that the appliance is switched off.**

Remove spillages and other types of incrustations.

Dust or food particles can be removed with a damp cloth.

If you use a detergent, please make sure that it is not abrasive or scouring. Abrasive or scouring powders can damage the glass surface of the hob.

All traces of the cleaner must be removed with a damp cloth.

Do not put articles on the hob which can melt: i.e plastic, aluminium foil, sugar, sugar syrup mixtures etc.

If any of these products items have melted on the ceramic surface, you should remove it immediately (when the surface is still hot) by using a scraper to avoid any permanent damage to the surface of the hob. (Available under part No. 103138).

Avoid using a knife or other sharp utensils since these can damage the ceramic.

Do not use steel wool or an abrasive sponge which could scratch the surface permanently.

#### **ATTENTION: MOST IMPORTANT!**

**If cleaning the glass ceramic hob using a special scraper tool take extra care to avoid damaging the seal at the edges of the glass ceramic surface.**

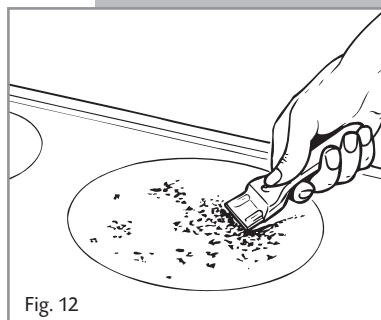

Fig. 12

## How to Use the Multifunction Main Oven

### General Features



As its name indicates, this is an oven that presents particular features from an operational point of view.

In fact, it is possible to insert 7 different programmes to satisfy every cooking need.

The 7 positions, thermostatically controlled, are obtained by 4 heating elements which are:

- Bottom element      1200 W
- Top element          1000 W
- Grill element         2000 W
- Circular element     2200 W

### Note:

Upon first use, it is advisable to operate the oven for 30 minutes in the position  and for another 30 minutes at the maximum temperature (thermostat knob on position 250) in the positions  and , to eliminate possible traces of grease on the heating elements.

Clean the oven and accessories with warm water and washing-up liquid.

### WARNING:

**The door is hot, use the handle.**

### ATTENTION - MOST IMPORTANT

**Pay special attention not to touch the hot heating element inside the oven cavity.**

### Operating Principles

Heating and cooking in the MULTI-FUNCTION oven are obtained in the following ways:

#### a. by normal convection

The heat is produced by the upper and lower heating elements.

#### b. by forced convection

A fan sucks in the air contained in the oven muffle, which sends it through the circular heating element and then sends it back through the muffle. Before the hot air is sucked back again by the fan to repeat the described cycle, it envelops the food in the oven, provoking a complete and rapid cooking.

It is possible to cook several dishes simultaneously.

#### c. by semi-forced convection

The heat produced by the upper and lower heating elements is distributed throughout the oven by the fan.

#### d. by radiation

The heat is radiated by the infra red grill element.

#### e. by radiation and ventilation

The irradiated heat from the infra red grill element is distributed throughout the oven by the fan.

#### f. by ventilation

The food is defrosted by using the fan only function without heat.

### Attention:

The oven door becomes very hot during operation.

### Thermostat Knob (fig. 13)

This only sets the cooking temperature and does not switch the oven on.

Rotate clockwise until the required temperature is reached (from 50 to 250°C).

The light between the thermostat and the function selector will illuminate when the oven is switched on and turns off when the oven reaches the correct temperature.

The light will cycle on and off during cooking in line with the oven temperature.

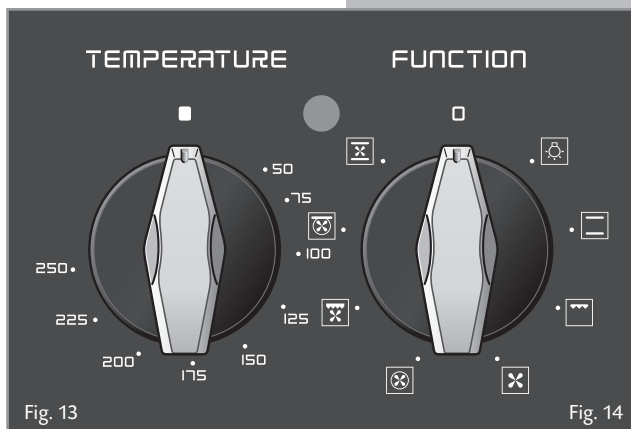

Fig. 13

Fig. 14

### Function Selector knob (fig. 14)

Rotate the knob clockwise to set the oven for one of the following functions.



#### Oven Light

By setting the knob to this position, only the oven light comes on. It remains on in all the cooking modes.



#### Traditional Convection Cooking

The upper and lower heating elements come on. The heat is dispersed by natural convection and the temperature must be set to between 50° and 250°C via the thermostat knob.

The oven must be preheated before cooking.

#### Recommended for:

Food that requires the same degree of cooking both inside and out, for example roasts, spare pork ribs, meringues etc.



### Grilling

The infrared grill element comes on. The heat is dispersed by radiation.

Use with the **oven door closed** and the thermostat knob to position **225°C** for max 15 minutes, then to position **175°C**.

For cooking hints, see the chapter "USE OF THE GRILL".

#### **Recommended for:**

Intense grilling, browning, cooking au gratin and toasting etc.

**It is recommended that you do not grill for longer than 30 minutes at any one time.**

**Caution: the oven door becomes very hot during operation. Keep children well out of reach.**



### Defrosting Frozen Foods

Only the oven fan comes on. Use with the thermostat knob set to "■" - other positions have no effect. The food is thawed by ventilation without heating.

#### **Recommended for:**

Quick thawing of frozen foods; one kg requires approximately 1 hour.

Thawing times vary according to the quantity and type of food to be thawed.



### Hot Air Cooking

The circular element and fan come on. The heat is dispersed by forced convection and the temperature can be regulated to between 50° and 250°C via the thermostat knob. The oven does not require preheating.

#### **Recommended for:**

Food which has to be well-cooked outside and soft or rosy inside, for example lasagne, lamb, roast beef, whole fish etc.



### Ventilated Grill Cooking

The infrared grill element and the fan come on. The heat is dispersed mainly by radiation and the fan then distributes it all over the oven.

**Use with the door closed.** The temperature can be regulated via the thermostat knob to between 50° and 175° max.

The oven must be preheated for approximately 5 minutes. For cooking hints, see the chapter "GRILLING AND AU GRATIN."

#### Recommended for:

Grilling where quick browning on the outside is required to keep the juices in.

For example: veal steaks, chops, hamburgers etc.

**It is recommended that you do not grill for longer than 30 minutes at any one time.**

**Caution: the oven door becomes very hot during operation. Keep children well out of reach.**



### Maintaining Temperature After Cooking or Slowly Heating Foods

The upper heating element, the circular element and the fan come on.

The heat is dispersed by forced convection with greater intensity in the upper part.

The temperature can be set to between 50° and 140°C via the thermostat knob.

#### Recommended for:

Keeping food warm after any type of cooking. Slow heating of cooked food.



### Convection Cooking with Ventilation

The upper and lower heating elements come on and the fan.

The heat coming from above and below is dispersed by convection with ventilation.

The temperature can be set to between 50° and 250°C via the thermostat knob.

#### Recommended for:

Voluminous dishes and large quantities which require the same degree of cooking both inside and out, for example rolled roasts, turkey, roast legs, cakes etc.



## Cooking Advice

### Sterilization

Sterilization of foods to be conserved, in full and hermetically sealed jars, is done in the following way:

- Set the switch to position .
- Set the thermostat knob to position 185 °C and preheat the oven.
- Fill the dripping pan with hot water.
- Set the jars onto the dripping pan making sure they do not touch each other and the door and set the thermostat knob to position 135 °C.



When sterilization has begun, that is, when the contents of the jars start to bubble, turn off the oven and let cool.

### Regeneration

Set the switch to position  and the thermostat knob to position 150° C.

Bread becomes fragrant again if wet with a few drops of water and put into the oven for about 10 minutes at the highest temperature.

### Simultaneous Cooking of Different Foods

The MULTI-FUNCTION oven set on position  and  gives a simultaneous heterogeneous cooking of different foods. Different foods such as fish, cake and meat can be cooked together without mixing the smells and flavors together. This is possible since the fats and vapors are oxidized while passing through the electrical element and therefore are not deposited onto the foods.

The only precaution to follow are:

- The cooking temperatures of the different foods must be as close to as possible, with a maximum difference of 20° - 25 °C.
- The introduction of the different dishes in the oven must be done at different times in relation to the cooking times of each one.

The time and energy saved with this type of cooking is obvious.

### Grilling and "Au Gratin"

Grilling may be done without the roasting rack on position  of the switch, because the hot air completely envelops the food that is to be cooked.

Set the thermostat to position 175 °C and after having preheated the oven, simply place the food on the rack.

Close the door and let the oven operate with the thermostat on position 175 °C, until grilling is done.

Adding a few dabs of butter before the end of the cooking time gives the golden "au gratin" effect.

#### Grilling with the oven door closed.

**It is recommended that you do not grill for longer than 30 minutes at any one time.**

**Caution: the oven door becomes very hot during operation. Keep children well out of reach.**

## Roasting

To obtain classical roasting, it is necessary to remember:

- that it is advisable to maintain a temperature between 180° and 200 °C.
- that the cooking time depends on the quantity and the type of foods.

## Use of the Grill

- Preheat the oven for about 5 minutes.
- Introduce the food to be cooked, positioning the rack as close to the grill as possible.
- The dripping pan should be placed under the rack to catch the cooking juices and fats.

**Grilling with the oven door closed.**

**Do not grill for longer than 30 minutes at any one time.**

**Caution: the oven door becomes very hot during operation. Keep children well out of reach.**



## How to Use the Conventional Oven

### General Features

As its name indicates, this is an oven that presents particular features from an operational point of view. The conventional oven is provided with 3 heating elements which are:

- Bottom element      800 W
- Top element         700 W
- Grill element        1450 W

### Note:

Upon first use, it is advisable to operate the oven at the maximum temperature (thermostat knob on position 250) for 60 minutes in the position  and for another 15 minutes in the position  to eliminate possible traces of grease on the heating elements. liquid.

### WARNING:

**The door is hot, use the handle.**

### ATTENTION - MOST IMPORTANT

**Pay special attention not to touch the hot heating element inside the oven cavity.**

### Thermostat Knob (fig. 16)

This only sets the cooking temperature and does not switch the oven on.

Rotate clockwise until the required temperature is reached (from 50 to 250°C).

The light between the thermostat and the function selector will illuminate when the oven is switched on and turns off when the oven reaches the correct temperature.

The light will cycle on and off during cooking in line with the oven temperature.

### Attention:

The oven door becomes very hot during operation.

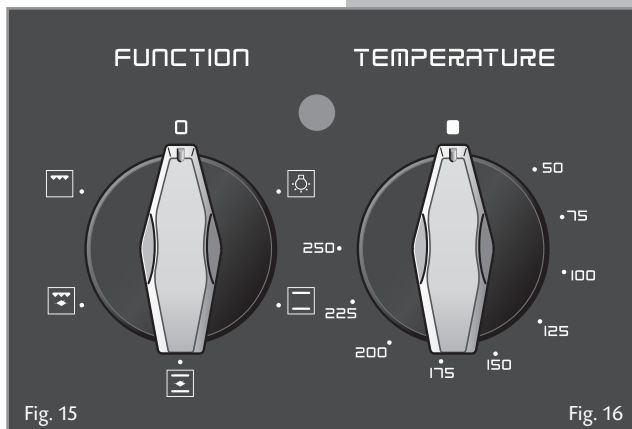

Fig. 15

Fig. 16

## Function Selector Knob (fig. 15)

Rotate the knob clockwise to set the oven for one of the following functions.



### Oven Light

By setting the knob to this position, only the oven light comes on. It remains on in all the cooking modes.



### Traditional Convection Cooking

The upper and lower heating elements come on.

The heat is dispersed by natural convection and the temperature must be set to between 50° and 250°C via the thermostat knob. The oven must be preheated before cooking.

In the  position the rotisserie motor come on for cooking with the rotisserie.

#### Recommended for:

Food that requires the same degree of cooking both inside and out, for example roasts, spare pork ribs, meringues etc.



### Traditional Grilling

The infrared grill element comes on. The heat is dispersed by radiation.

Use with the **oven door closed** and the thermostat knob to position **225°C** for max 15 minutes, then to position **175°C**.

In the  position the rotisserie motor come on for cooking with the rotisserie.

For cooking hints, see the chapter "USE OF THE GRILL".

#### Recommended for:

Intense grilling, browning, cooking au gratin and toasting etc.



**It is recommended that you do not grill for longer than 30 minutes at any one time.**

**Caution: the oven door becomes very hot during operation.**

**Keep children well out of reach.**

## Use of the Grill

Switch the grill on, setting the two knobs:

- Function selector to  or  position.
- Thermostat selector to position **225°C** for 15 minutes then to **175°C**.

Leave to warm up for approximately 5 minutes with the door **closed**.

Place the food inside positioning the rack as near as possible to the grill.

Insert the drip pan under the rack to collect the cooking juices.

Grilling with the oven door closed and **do not for longer than 30 minutes at any one time**.

**Attention: the oven door becomes very hot during operation.**

**Keep children away.**

## Rotisserie

**The oven is equipped with a rotisserie.**

This device is made up of:

- an electrical motor mounted on the rear part of the oven
- a stainless steel rod, equipped with a detachable athermic handle and 2 recordable forks
- a rod support to be inserted into the central rack holders of the oven.

## Use of the Rotisserie

- Insert the dripping pan into the lowest rack holders of the oven and insert the rod support into the intermediate rack holders.
- Put the meat to be cooked onto the rod, being careful to secure it in the center with the special forks.
- Insert the rod into the motor opening and rest it onto the support of the spit collar; then remove the grip by turning it to the left.

The rotation direction of the rotisserie can be either clockwise or counter-clockwise.

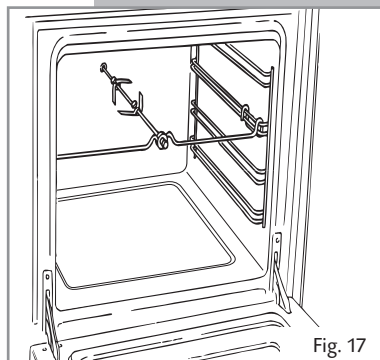

## Use of Special Dish Rack

This special shelf can be used as dish rack or turning over, as normal shelf for oven cooking. It must be inserted between the guides of the lateral racks.

### Using the Special Shelf as a Dish Rack

Slide in the shelf on the guides, on the lower level of the lateral racks.

The prongs where the plates are to be inserted, must be turned upwards.

The shelf must be fitted so that the safety catch, which stops it sliding out, faces the bottom of the oven (see detail of figure 18).

The plates must be positioned as indicated in figure 18.

To facilitate this operation, pull the special rack up to the safety lock.

**KEEP Attention: Plates are hot after warming. It is advisable to handle the plates using oven gloves.**

### Using the Special Rack for Normal Cooking

Slide in the shelf on the guides: the safety catch must be turned toward the oven base (see detail of figure 19).

The flat surface can be used to put cooking pans or food directly on the rack - the dripping pan should be placed under the rack to catch the cooking juices and fats.

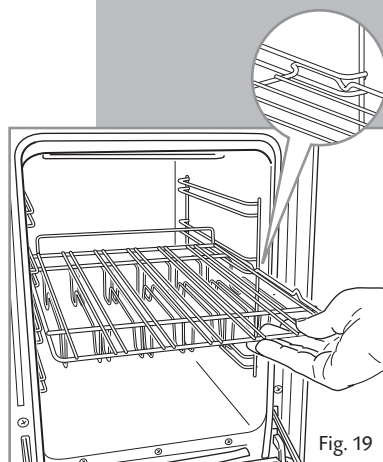
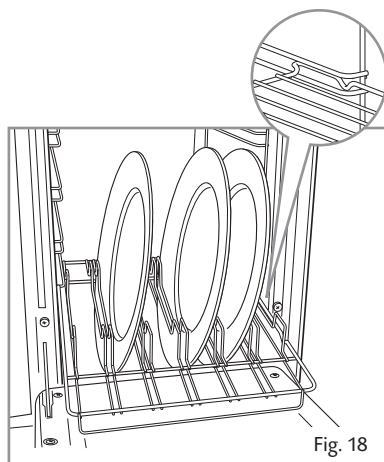

## Do's and do not's

- Do always grill with the oven door closed.
- Do read the user instructions carefully before using the cooker for first time.
- Do allow the oven to heat for one and a half hours, before using for the first time, in order to expel any smell from the new oven insulation, without the introduction of food.
- Do clean your oven regularly.
- Do remove spills as soon as they occur.
- Do always use oven gloves when removing food shelves and trays from the oven.
- Do not allow children near the cooker when in use.
- Do not allow fat or oils to build up in the oven trays, or oven base.
- Do not place cooking utensils or plates directly onto the oven base.
- Do not grill food containing fat without using the grid.
- Do not cover the grilling grid with aluminium-foil.
- Do not use the oven tray for roasting.
- Do not place hot enamel parts in water. Leave them to cool first.
- Do not allow vinegar, coffee, milk, saltwater, lemon or tomato juice to remain in contact with enamel parts (inside the oven and on the oven tray).
- Do not use abrasive cleaners or powders that will scratch the surface of the stainless steel and the enamel.
- Do not attempt to repair the internal workings of your cooker.
- Do remove the protective film before the first use.
- **Fire risk!** Do not store flammable material in the oven or in the storage drawer.

## For Your Safety

- The product should only be used for its intended purpose which is for the cooking of domestic foodstuffs.
- Under no circumstances should any external covers be removed for servicing or maintenance except by suitably qualified personnel.
- **Attention: The appliance gets very hot, mainly around the cooking areas. It is very important that children are not left alone in the kitchen when you are cooking.**
- Household appliances are not intended to be played with by children.
- Keep children away from the appliance during use.
- Children, or persons with a disability which limits their ability to use the appliance, should have a responsible person to instruct them in its use. The instructor should be satisfied that they can use the appliance without danger to themselves or their surroundings.
- Do not operate your appliance by means of an external timer or separate remote-control system.

## Important Notes

Installation, and any demonstration, information or adjustments are not included in the warranty. The cooker must be installed by a suitably qualified and registered person in accordance with the relevant Standards.

## Care and Maintenance

### Important:

As a safety measure, before you start cleaning the cooker be sure to disconnect it from the mains supply.

- **Do not use cleaning products with a chlorine or acidic base.**
- **Do not use a steam cleaner because the moisture can get into the appliance thus make it unsafe.**
- **The use of suitable protective clothing/gloves is recommended when handling or cleaning of this appliance.**

### WARNING

When correctly installed, your product meets all safety requirements laid down for this type of product category.

However special care should be taken around the rear or the underneath of the appliance as these areas are not designed or intended to be touched and may contain sharp or rough edges, that may cause injury.

### Spillage

Any spillage should be dealt with as soon as possible to prevent it becoming burnt on.

### Vitroc ceramic Cooking Hob

- See page 12.

### Enamelled Parts

All the enamelled parts must be cleaned with a sponge and soapy water only or other non-abrasive products.

Dry preferably with a micro fibre or soft cloth.

### Stainless Steel, Aluminium, Painted Parts and Silk-screen Printed Surfaces

Clean using an appropriate product. Always dry thoroughly.

Stainless steel surfaces: can be cleaned with an appropriate stainless steel cleaner.

**IMPORTANT:** these parts must be cleaned very carefully to avoid scratching and abrasion. You are advised to use a soft cloth and neutral soap.

**CAUTION: Do not use abrasive substances or non-neutral detergents as these will irreparably damage the surface.**



## Replacing the Halogen Oven Lights

**WARNING: Ensure the appliance is switched off before replacing the lamp to avoid the possibility of electric shock.**

- Let the oven cavity and the heating elements to cool down;
- Switch off the electrical supply;
- Remove the protective cover **C** (fig. 20);
- Replace the halogen lamp **B** with a new one suitable for high temperatures having the following specifications: 230V and same power (check watt power as stamped in the lamp itself) of the replaced lamp.

**IMPORTANT WARNING: Never replace the bulb with bare hands; contamination from your fingers can cause premature failure.**

**Always use a clean cloth or gloves.**

- Refit the protective cover;

**Note: Oven bulb replacement is not covered by your guarantee.**

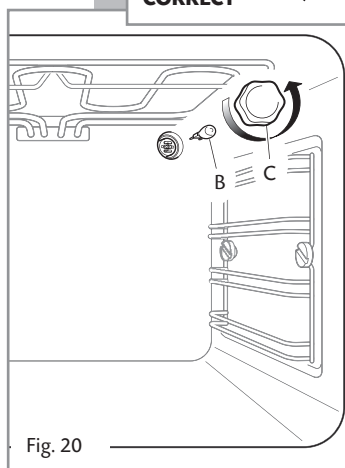
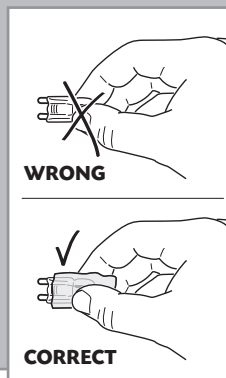

Fig. 20

## Drawer

The drawer (fig. 21) comes out like a normal drawer.

**Attention: Do not store flammable material in the ovens, or the drawer.**

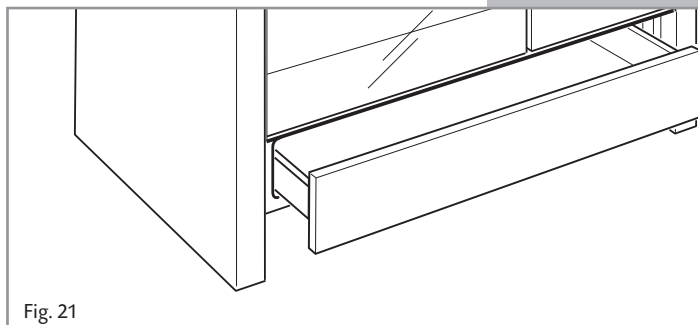

Fig. 21

## Inside of Ovens

The ovens should always be cleaned after use when they have cooled down.

The cavity should be cleaned using a mild detergent solution and warm water. Suitable proprietary chemical cleaners may be used after first consulting with the manufacturers recommendations and testing a small sample of the oven cavity. Abrasive cleaning agents or scouring pads/cloths should not be used on the cavity surface.

**NOTE:** The manufacturers of this appliance will accept no responsibility for damage caused by chemical or abrasive cleaning.

**Let the oven cool down and pay special attention no to touch the hot heating elements inside the oven cavity.**

## Assembling and Dismantling of the Side Runner Frames

- Fit the side runner frames into the holes on the side walls inside the oven (Fig. 22).
- Slide the tray and rack into the runners (Fig. 23).  
The rack must be fitted so that the safety catch, which stops it sliding out, faces the inside of the oven.
- To dismantle, operate in reverse order.

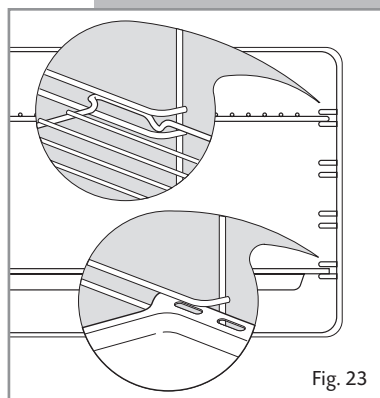
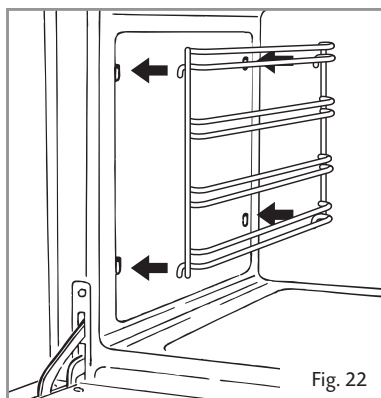

## Oven Doors

### Removing the Oven Doors

Please operate as follows:

- Open the door completely.
- The swivel retainers of the rh and lh hinges (fig. 24a) are hooked onto the metal bar above them (fig. 24b).
- Lift the oven door slightly. The notch on the bottom of the hinge will disengage (fig. 24c).
- Now pull the oven door forwards off the appliance. Release both hinge sections from the slots (fig. 24d).

### Doors Assembly

- Grip the door (as indicated in figure 24) and refit it in reverse order of removing procedure.

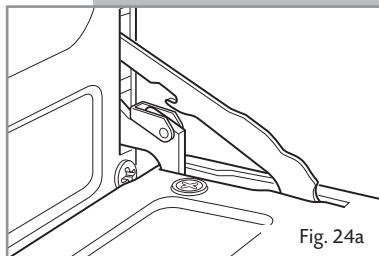

Fig. 24a

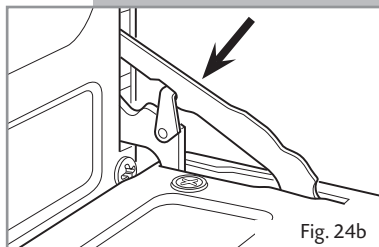

Fig. 24b

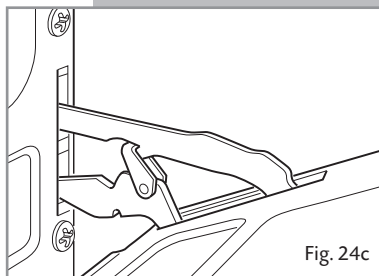

Fig. 24c

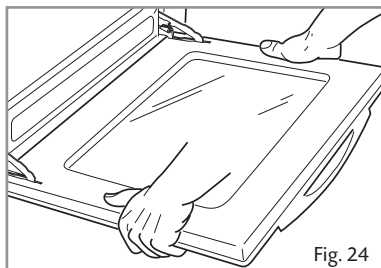

Fig. 24

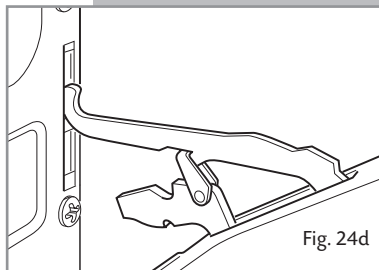

Fig. 24d

## Over Doors - Cleaning The Panes Of Glass

The oven doors have two panes. To clean these, you need to remove the inner pane.

### Removing the Inner Pane

- Open the door to the full extent (fig. 24a).
- Attach the swivel retainers of the rh and lh hinges onto the metal bar above them (fig. 24b).
- Gently pull out the inner pane of glass (Fig. 25a).
- Clean the glass with an appropriate cleaner.
- Dry thoroughly, and place the pane on a soft surface.
- Now you can also clean the inside of the outer glass.

**Do not use harsh abrasive cleaners or sharp metal scrapers to clean the panes of glass since they can scratch the surface, which may result in shattering of the glass.**

### Reassembling the Inner Pane

- Check the correct positioning of the no.4 (four) silicon rubbers **D** (fig. 25b).
- Check that you are holding the pane the correct way. You should be able to read the wording on it as it faces you.
- Insert the inner pane in the left **E** and right **F** side guides (fig. 25c) and gently let it slide up to the retainers **H** (fig. 25d).
- Unlock the oven door by opening it completely and detaching the swivel retainers of the lh and rh hinges from the metal bar above them (fig. 24a).

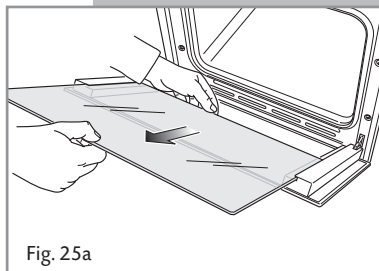

Fig. 25a

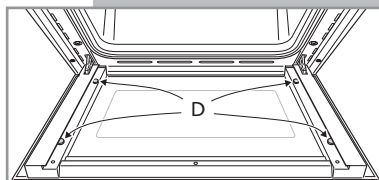

Fig. 25b

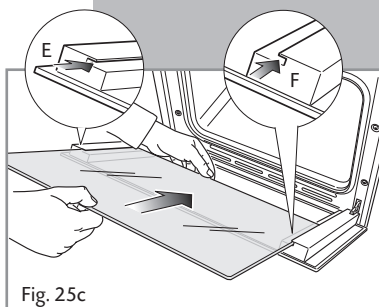

Fig. 25c

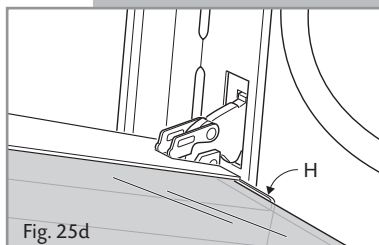
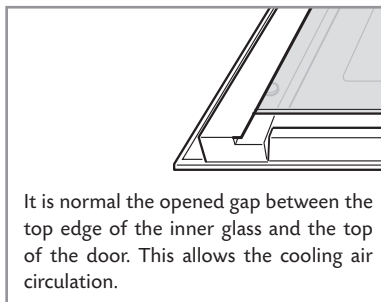

Fig. 25d

## FOR THE INSTALLER

### Location

The appliance is designed and approved for domestic use only and should not be installed in a commercial, semi commercial or communal environment.

Your product will not be guaranteed if installed in any of the above environments and could affect any third party or public liability insurances you may have.

### Important

- The appliance should be installed by a qualified electrician in compliance with the laws in force in your country and in observation of the instructions supplied by the manufacturer.  
Failure to comply with this condition will render the guarantee invalid.
- Always disconnect the cooker from mains power supply before carrying out any maintenance operations or repairs.

The cooker must be installed no less than 50mm away from any side wall which exceed the height of the cooktop.

**The appliance must be housed in heat resistant units.**

**The walls of the units must be capable of resisting temperatures of 75°C above room temperature.**

**Do not install the appliance near inflammable materials (eg. curtains).**

If the cooker is located on a pedestal it is necessary to provide safety measures to prevent falling out.

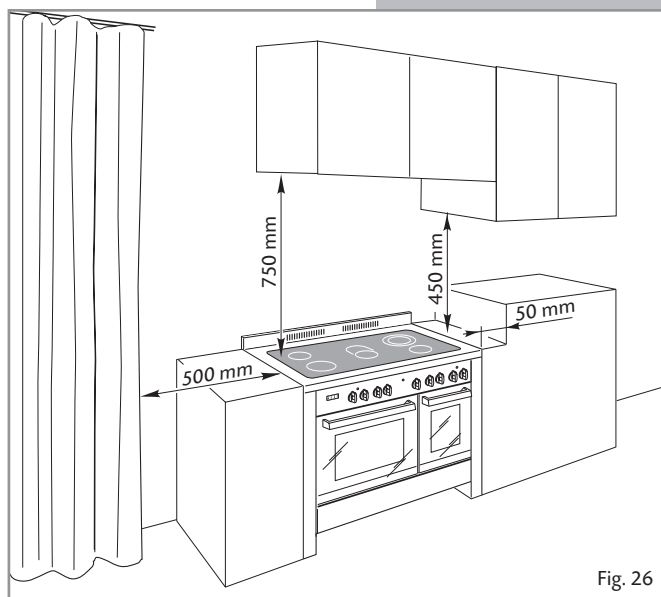

Fig. 26

## Assembling the Backguard

Before installing the cooker, assemble the backguard **V** (fig. 27).

Please note that :

- The backguard **V** can be found packed at the rear of the cooker.
- Before assembling remove any protective film/adhesive tape.
- The backguard must be fixed to the cooktop using the three supports **B** and screws **A** supplied with the appliance (see fig. 27).

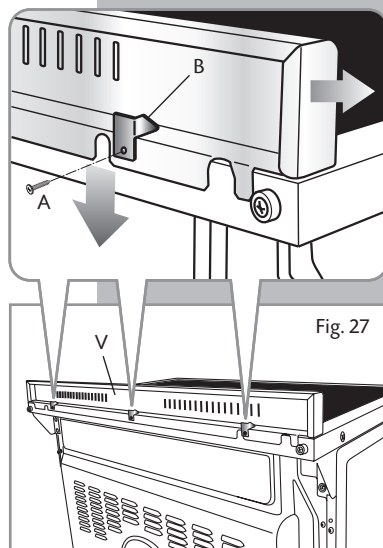

## Levelling the Cooker

The cooker is equipped with 4 levelling feet and may be levelled by screwing or unscrewing the feet with a spanner (fig. 28).

It is important to observe the prescriptions of figures 28a - 28b.

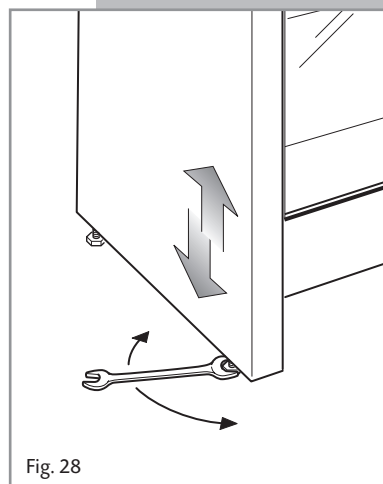
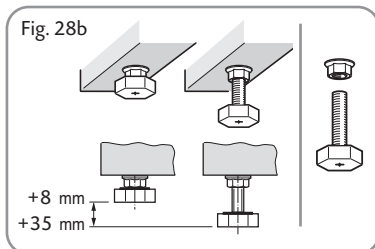
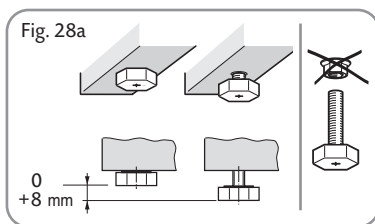

**Warning**

To move the cooker always ensure two people carry out this manoeuvre to prevent damage to the appliance (fig. 29).

**Warning**

Be careful: do not lift the cooker by the door handles (fig. 30).

**Warning**

When moving cooker to its final position **DO NOT DRAG** (fig. 31).

Lift feet clear of floor (fig. 29).

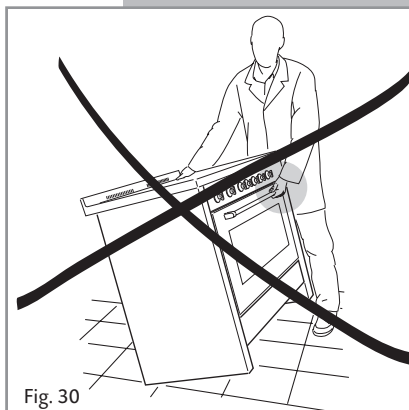
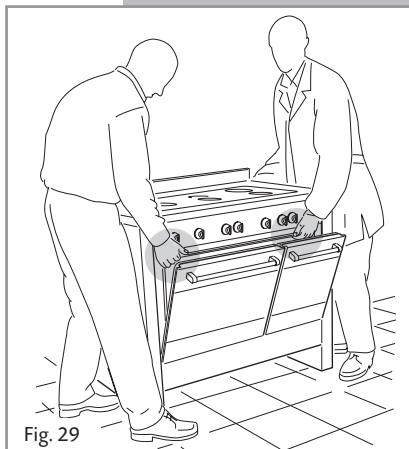

## Stability Bracket

We recommend a stability bracket is fitted to the cooker.

The type shown in fig. 33 can be purchased from most plumbers merchants and do it yourself (D.I.Y.) shops.

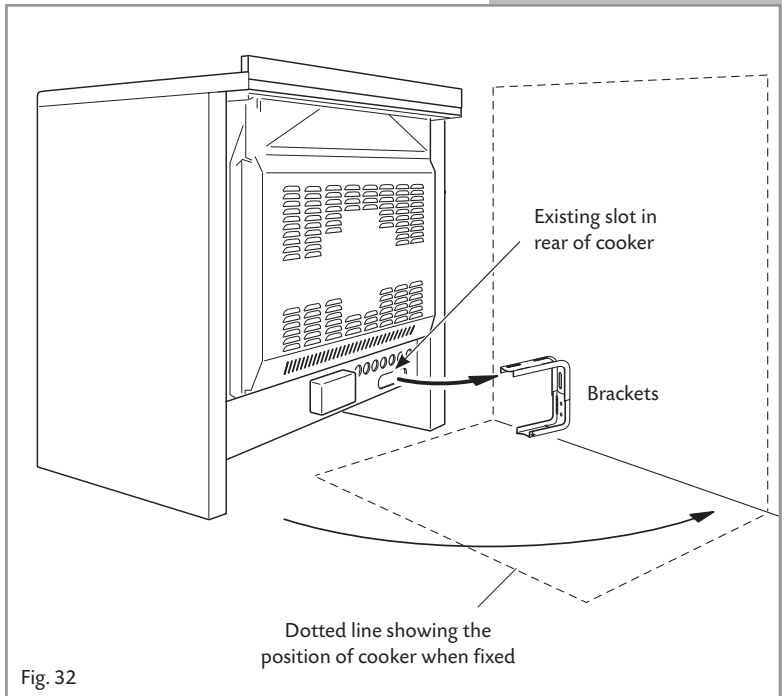
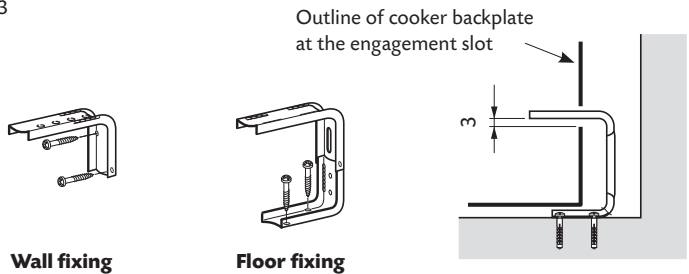

Fig. 33





## Electrical Installation

**IMPORTANT: The cooker must be installed in accordance with the manufacturer's instructions.**

**Incorrect installation, for which the manufacturer accepts no responsibility, may cause injury to persons, animals or equipment.**

### **For Your Safety Please Read the Following Information:**

- **Connection to the mains must be carried out by a qualified technician in accordance with current regulations.**
- The appliance must be connected to the mains checking that the voltage corresponds to the value given in the rating plate and that the electrical cable sections can withstand the load specified on the plate.
- The cooker can be connected directly to the mains placing an omnipolar switch with minimum opening between the contacts of 3 mm between the appliance and the mains.
- The power supply cable must not touch any hot parts and must be positioned so that it does not exceed 75°C at any point.
- Once the cooker has been installed, the switch must always be accessible.

**N.B. For connection to the mains, do not use adapters, reducers or branching devices as they can cause overheating and burning.**

If the installation requires alterations to the domestic electrical system, call an expert.

He should also check that the domestic electrical system is suitable for the power absorbed by the appliance.

- **The connection of the appliance to earth is mandatory.**  
**The manufacturer declines all responsibility for any inconvenience resulting from the non observance of this condition.**

**IMPORTANT: this cooker must be connected to a suitable double pole control unit adjacent to the cooker.**

**No diversity can be applied to this control unit.**

**Before carrying out any work on the electrical parts of the appliance, the appliance must first be disconnected from the electrical supply.**

**Connecting the power cord must be entrusted to skilled personnel in accordance with the instructions supplied by the manufacturer and in compliance with established safety standards.**

### Connecting the Mains Cable

To connect the feeder cable to the cooker it is necessary to:

- Remove the two screws that hold shield **A** behind the cooker (fig. 34).
- Open completely the cable clamp **D**.
- Insert the mains cable (see FEEDER CABLE SECTION) into the cable clamp **D**.
- Connect the phase and earth cables to terminal **B** according to figs. 35 - 36.
- Pull the feeder cable and block it with the cable clamp **D**.
- Re-mount shield **A**.

### Feeder Cable Section

#### "TYPE H05RR-F or H05VV-F"

230 V~ 3 x 4 mm<sup>2</sup>

- (\*\*) - Connection with wall box connection.
- Diversity factor applied.
  - A diversity factor may be applied to the total loading of the cooker only by a suitable qualified person.

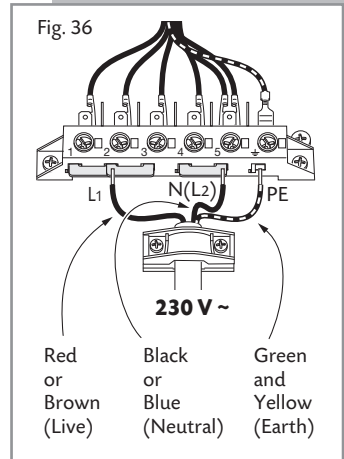
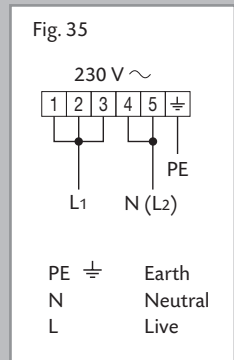
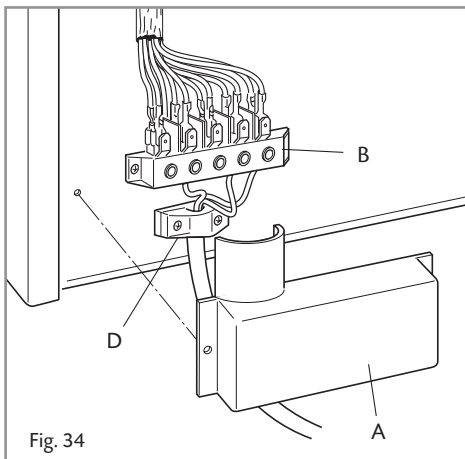

## Appliance Servicing

CDA provide a quality and effective after-sales service to cover all your servicing needs.

Please attach your receipt to this page for safekeeping.

Please help us to help you by having the following information available when booking a service-call:

1. Model type, make and model – see the product data plate.
2. Evidence of installation / purchase date
3. Retailer where appliance was purchased
4. Clear and concise details of the fault
5. Full address including postcode and any contact phone numbers

### Contact Telephone Numbers

CDA Customer Care Department

– Telephone: 01949 862012

– Fax: 01949 862003

– Email: [service@cda.eu](mailto:service@cda.eu)

## Guarantee

CDA appliances carry a five-year parts and a one-year labour guarantee.

CDA will repair or replace any defect or part attributable to faulty material or workmanship. Within the first year this will be free of both labour and parts charges. After the first year and within five years, the parts will be supplied free of charge provided that the repair is carried out by an agent authorised by CDA and the labour will be charged at the commercial rate applicable at the time of repair.

The appliance must have been installed by a suitably qualified person and in accordance with the manufacturer's instructions and current legislation. The guarantee does not cover faults caused by the incorrect fitting of appliances.

### Limit of Cover

- The guarantee does not cover cosmetic damage e.g. discolouration or oxidisation.
- Proof of purchase or installation date must be produced before a service-call will be booked.
- The appliance must be used for domestic purposes only. Appliances used for commercial or professional purposes are not covered by the guarantee. Commercial warranty is available at extra cost.
- The appliance must not be modified or tampered with or repair attempted by any unauthorised person.
- The guarantee does not cover damage caused in transit or by misuse, accident, abuse or neglect.
- The guarantee does not cover routine maintenance.
- Use of parts not supplied or recommended by [C|D|A] will invalidate the warranty.
- Rubber seals, filters, removable glass parts, control knobs and buttons, fuses and light bulbs will need replacing periodically and are not covered by the guarantee.
- Second-hand or reconditioned appliances are not covered by the guarantee.

The conditions under which this guarantee is offered are in addition to the statutory rights of the domestic purchaser and these statutory rights are not affected by this guarantee.

CDA reserve the right to change specification without prior notice.



To contact our Customer Care Department, or for Service,  
please contact us on the details below.

## Free Manuals Download Website

<http://myh66.com>

<http://usermanuals.us>

<http://www.somanuals.com>

<http://www.4manuals.cc>

<http://www.manual-lib.com>

<http://www.404manual.com>

<http://www.luxmanual.com>

<http://aubethermostatmanual.com>

Golf course search by state

<http://golfingnear.com>

Email search by domain

<http://emailbydomain.com>

Auto manuals search

<http://auto.somanuals.com>

TV manuals search

<http://tv.somanuals.com>